

UT54ALVC2525 Clock Driver

1 to 8 Minimum Skew

Data Sheet

February 2016

The most important thing we build is trust

FEATURES

- ❑ 2.0V to 3.6V Power supply operation
- ❑ Guaranteed pin-to-pin and part-to-part skew
- ❑ Eight LVTTTL outputs with high drive strength
- ❑ Operational environment:
 - Total-dose tolerance: 100 to 300 krad(Si), or 1 Mrad(Si)
 - SEL Immune to a LET of 111 MeV-cm²/mg
- ❑ HiRel temperature range: -55°C to +125°C
- ❑ Packaging options:
 - 14-Lead Ceramic Flatpack
- ❑ Standard Microcircuit Drawing: 5962-06233
 - QML Q and V

INTRODUCTION

The UT54ALVC2525 is a low-voltage, minimum skew, one-to-eight clock driver. The UT54ALVC2525 distributes a single clock to eight, high-drive, outputs with low skew across all outputs during both the t_{PLH} and t_{PHL} transitions making it ideal for signal generation and clock distribution. The output pins act as a single entity and will follow the state of the CLK pin.

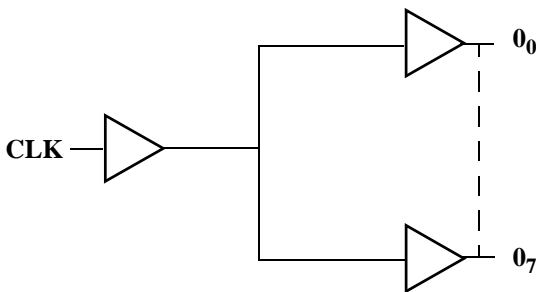

Figure 1: UT54ALVC2525 Block Diagram

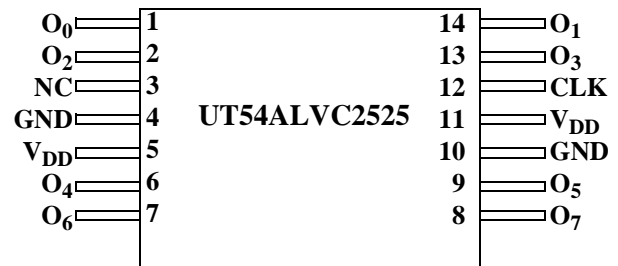

Figure 2. 14-Lead Ceramic Flatpack Pinouts

PIN DESCRIPTION

Flatpack Pin No.	Name	I/O	Type	Description
12	CLK	I	LVTTL	Primary reference clock input. This pin must be driven by an LVTTL or LVCMOS clock source.
3	N/C	--	--	No connect.
1, 2, 6, 7, 8, 9, 13, 14	O _n	O	LVTTL	Eight output clocks.
5, 11	V _{DD}	PWR	Power	Power supply for internal circuitry and output buffers.
4, 10	V _{SS}	PWR	Power	Ground

OPERATIONAL ENVIRONMENT

The UT54ALVC2525 incorporates special design, layout, and process features which allows operation in a limited HiRel environment.

Parameter	Limit	Units
Total Ionizing Dose (TID)	>1E6	rads(Si)
Single Event Latchup (SEL) ^{1, 2}	>111	MeV-cm ² /mg
Onset Single Event Upset (SEU) LET (@2.0V) ^{3, 5}	52	MeV-cm ² /mg
Onset Single Event Upset (SEU) LET (@3.0V) ^{4, 5}	66	MeV-cm ² /mg
Neutron Fluence	1.0E14	n/cm ²
Dose Rate Upset	TBD	rads(Si)/sec
Dose Rate Survivability	TBD	rads(Si)/sec

Notes:

1. The UT54ALVC2525 is latchup immune to particle LETs >111 MeV-cm²/mg.
2. SEL temperature and voltage conditions of T_C = +125°C, V_{DD} = 3.6V.
3. SEU temperature and voltage conditions of T_C = +25°C, V_{DD} = 2.0V. Tested at 200MHz.
4. SEU temperature and voltage conditions of T_C = +25°C, V_{DD} = 3.0V. Tested at 200MHz.
5. For the UT54ALVC2525 SET performance at select operating frequency data ranges, please contact the factory.

ABSOLUTE MAXIMUM RATINGS:¹

(Referenced to V_{SS})

Symbol	Description	Limits	Units
V_{DD}	Core Power Supply Voltage	-0.3 to 4.0	V
V_{IN}	Voltage Any Clock Input	-0.3 to $V_{DD} + 0.3$	V
V_{OUT}	Voltage Any Clock Output	-0.3 to $V_{DD} + 0.3$	V
I_I	DC Input Current	± 10	mA
P_D	Maximum Power Dissipation	1	W
T_{STG}	Storage Temperature	-65 to +150	°C
T_J	Maximum Junction Temperature ²	+150	°C
Θ_{JC}	Thermal Resistance, Junction to Case	20	°C/W
ESD_{HBM}	ESD Protection (Human Body Model) - Class II	>3000	V

Notes:

1. Stresses outside the listed absolute maximum ratings may cause permanent damage to the device. This is a stress rating only, and functional operation of the device at these or any other conditions beyond limits indicated in the operational sections of this specification is not recommended. Exposure to absolute maximum rating conditions for extended periods may affect device reliability and performance.
2. Maximum junction temperature may be increased to +175°C during burn-in and steady-static life.

RECOMMENDED OPERATING CONDITIONS:

Symbol	Description	Limits	Units
V_{DD}	Core Operating Voltage	2.0 to 3.6	V
V_{IN}	Voltage Clock Input	0 to V_{DD}	V
V_{OUT}	Voltage Any Clock Output	0 to V_{DD}	V
T_C	Case Operating Temperature	-55 to +125	°C

DC ELECTRICAL CHARACTERISTICS (Pre- and Post-Radiation)*

($V_{DD} = 2.0V$ to $3.6V$; $T_C = -55^{\circ}C$ to $+125^{\circ}C$)

Symbol	Description	Conditions	V_{DD}	Min.	Max.	Units
V_{IH}^1	High level input voltage		2.0V 2.75V 3.0V 3.6V	1.25 1.5 1.75 2.0		V
V_{IL}^1	Low level input voltage		2.0V 2.75V 3.0V 3.6V		0.7 0.8 0.8 0.8	V
V_{OL}	Low level output voltage	$I_{OL} = 12mA$ $I_{OL} = 12mA$ $I_{OL} = 12mA$ $I_{OL} = 12mA$	2.0V 2.75V 3.0V 3.6V		0.45 0.4 0.4 0.4	V
V_{OH}	High level output voltage	$I_{OH} = -12mA$ $I_{OH} = -12mA$ $I_{OH} = -12mA$ $I_{OH} = -12mA$	2.0V 2.75V 3.0V 3.6V	1.5 2.2 2.4 3.0		V
I_{OS}^2	Short-circuit output current	$V_{OUT} = V_{DD}$ and V_{SS}	2.0V 3.6V	-200 -300	200 300	mA
I_{IL}	Input leakage current	$V_{IN} = V_{DD}$ or V_{SS}	3.6V	-1	1	μA
I_{DDQ}	Quiescent Supply Current	$V_{IN} = V_{DD}$ or V_{SS}	2.0V 3.6V		1.0 1.0	mA
P_{TOTAL}^3	Total power dissipation	$C_L = 20pF$	2.0V 2.75V 3.0V 3.6V		1.2 2.7 3.5 5.2	mW/MHz
C_{IN}^4	Input capacitance	$f = 1MHz$	0V		15	pF
C_{OUT}^4	Output capacitance	$f = 1MHz$	0V		15	pF

Notes:

* Post-radiation performance guaranteed at $25^{\circ}C$ per MIL-STD-883 Method 1019, Condition A up to a TID level of $1.0E6$ rad(Si).

- Functional tests are conducted in accordance with MIL-STD-883 with the following test conditions: $V_{IH} = V_{IH}(\min) + 20\%$, -0% $V_{IL} = V_{IL}(\max) + 0\%$, -50% , as specified herein for the LVTTTL and LVCMOS inputs. Devices may be tested using any input voltage within the above specified range, but are guaranteed to $V_{IH}(\min)$, $V_{IL}(\max)$.
- Supplied as a design limit. Neither guaranteed nor tested.
- When measuring the dynamic supply current, all outputs are loaded in accordance with the equivalent test load defined in figure 3.
- Capacitance is measured for initial qualification and when design changes may affect the input/output capacitance. Capacitance is measured between the designated terminal and the VSS at a frequency of 1MHz and a signal amplitude of 50mV rms maximum.

AC ELECTRICAL CHARACTERISTICS (Pre- and Post-Radiation)*

($V_{DD} = 2.0V$ to $3.6V$; $T_C = -55^{\circ}C$ to $+125^{\circ}C$)

Symbol	Description	Condition	V_{DD}	Min.	Max.	Unit
t_R, t_F^3	Input rise/fall time	$V_{IH}(\text{min}) - V_{IL}(\text{max})$	3.6V		20	ns/V
$t_{PHL}^{1,2}$	Propagation delay: CLK to On, high-to-low transition	Measured as transition time between $V_{IN} = V_{DD} \div 2$ to $V_{OUT} = V_{DD} \div 2$	2.0V 2.75V 3.0V 3.6V	3.5 3.0 2.75 2.25	7.5 5.5 5.25 4.75	ns
$t_{PLH}^{1,2}$	Propagation delay: CLK to On, low-to-high transition	Measured as transition time between $V_{IN} = V_{DD} \div 2$ to $V_{OUT} = V_{DD} \div 2$	2.0V 2.75V 3.0V 3.6V	3.25 2.75 2.5 2.0	7.25 5.25 5.0 4.5	ns
$t_{OSHL}^{2,4,5}$	Maximum skew: common edge, output-to-output, high-to-low transition	Measured as $V_{On} = V_{DD} \div 2$ to $V_{Om} = V_{DD} \div 2$ where $n, m = 0$ to 7 ; n not equal to m @ $f_{CLK} = 200\text{MHz}$	2.0V 3.6V		0.15 0.25	ns
$t_{OSLH}^{2,4,5}$	Maximum skew: common edge, output-to-output, low-to-high transition	Measured as $V_{On} = V_{DD} \div 2$ to $V_{Om} = V_{DD} \div 2$ where $n, m = 0$ to 7 ; n not equal to m @ $f_{CLK} = 200\text{MHz}$	2.0V 3.6V		0.15 0.25	ns
t_{ORISE}^3 & t_{OFALL}	Output rise/fall time	Measured as transition time between $20\% * V_{OL}$ and $80\% * V_{OH}$ @ $f_{CLK} = 100\text{MHz}$	2.0V 3.6V		2.4 2.0	ns
$t_{PART}^{4,5}$	Part-part skew	Skew between the same output of any two devices under identical settings and conditions (V_{DD} , temp, air flow, frequency, etc).	2.0V 3.6V		0.1 0.15	ns
$t_{PBAL}^{1,4}$	Propagation delay balance: difference between same output, low-to-high and high-to-low transitions	Measured as transition time between $V_{IN} = V_{DD} \div 2$ to $V_{OUT} = V_{DD} \div 2$	2.0V 2.75V 3.0V 3.6V		0.43 0.3 0.26 0.21	ns

Notes:

* Post-radiation performance guaranteed at $25^{\circ}C$ per MIL-STD-883 Method 1019, Condition A up to a TID level of $1.0E6$ rad(Si).

1. Test load = 40pF , terminated to $V_{DD} \div 2$. All outputs are equally loaded. Reference Figure 3 for clock output loading.
2. Reference Figure 4 for AC timing diagram.
3. Supplied only as a design guideline, neither tested nor guaranteed.
4. Guaranteed by characterization, but not tested.
5. Test load = 40pF , terminated to $V_{DD} \div 2$. All outputs are equally loaded. Reference Figure 5 for clock output loading.

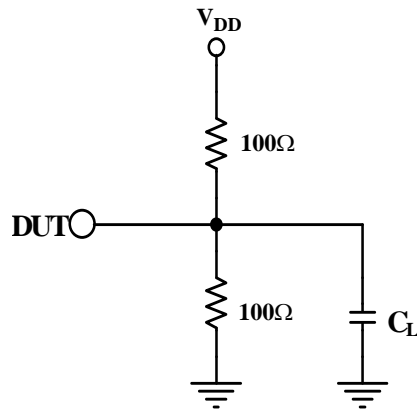

Figure 3.
Test Load Circuit for Dynamic Power Supply Current and AC Measurements

Note: This is not the recommended termination for normal user operation.

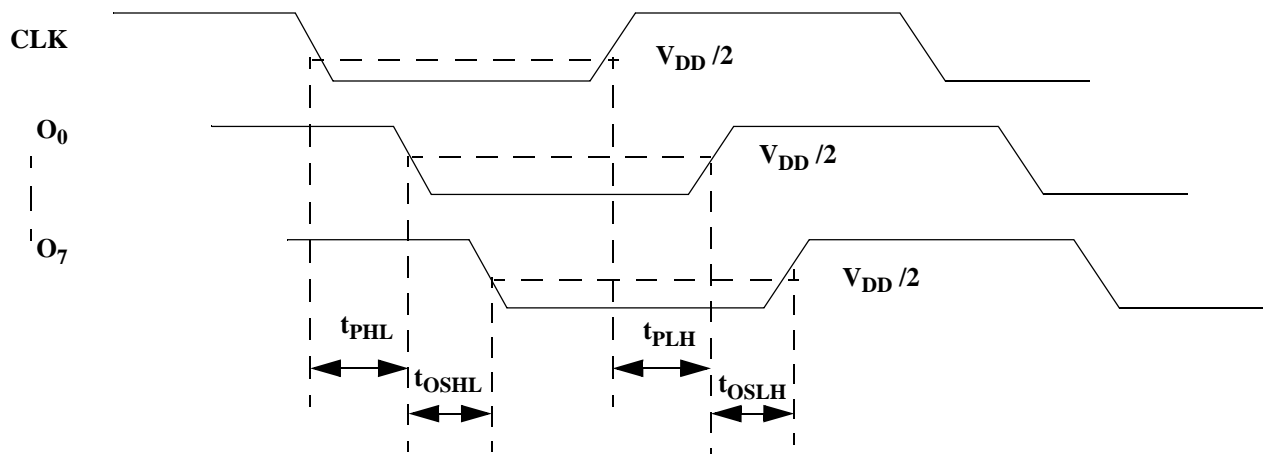

Figure 4. AC Timing Diagram

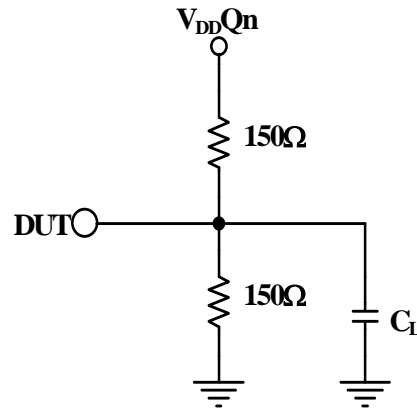
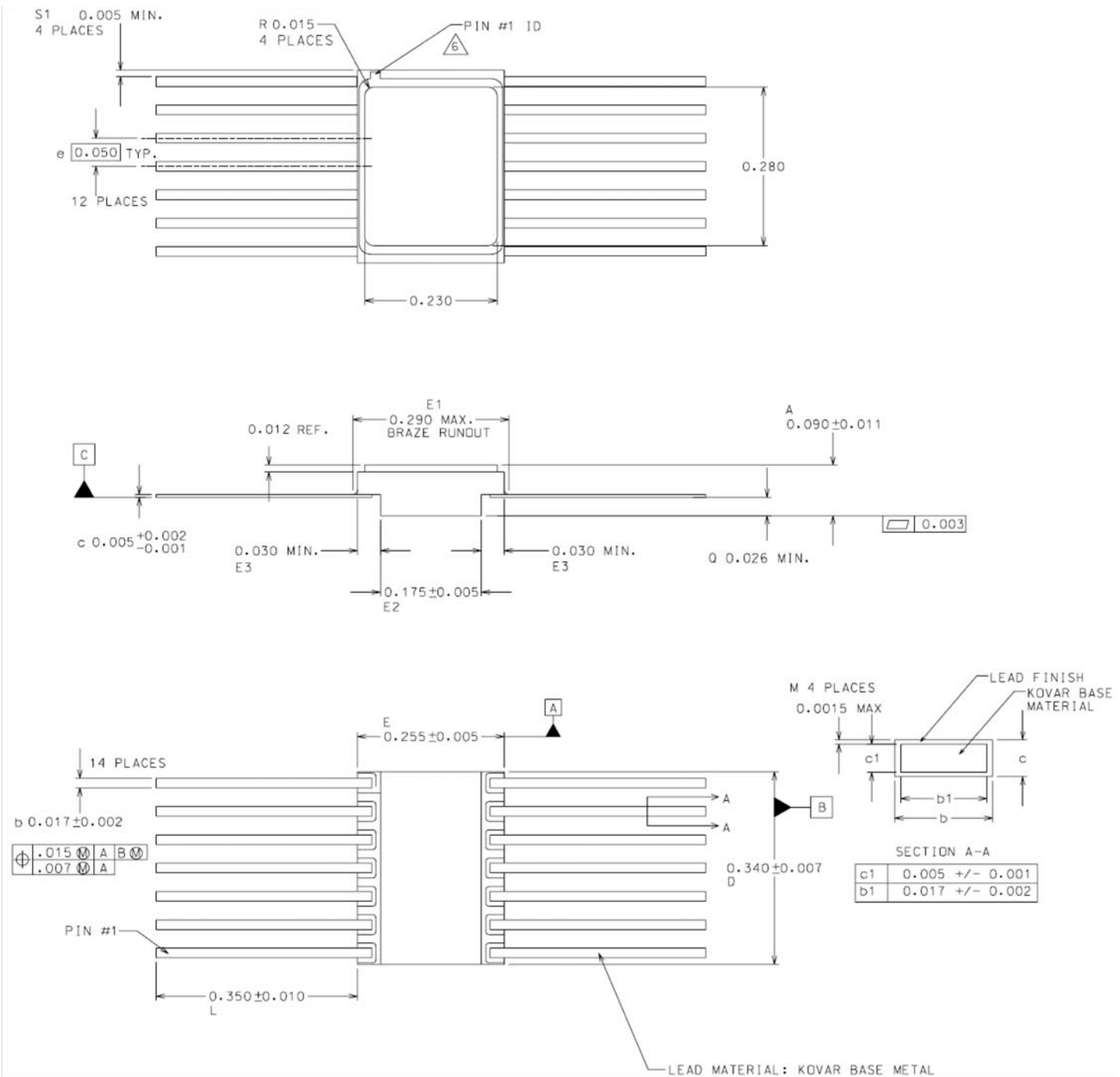

Figure 5. Test Load Circuit for t_{OSHL} and t_{OSLH} Measurements

PACKAGING



1. All exposed metallized areas are gold plated over electroplated nickel per MIL-PRF-38535.
2. The lid is electrically connected to V_{SS} .
3. Lead finishes are in accordance with MIL-PRF-38535.
4. Dimension symbol is in accordance with MIL-PRF-38533.
5. Lead position and colanarity are not measured.
6. ID mark symbol is vendor option.

Figure 6. 14-Pin Flatpack Package

ORDERING INFORMATION

UT54ALVC2525:

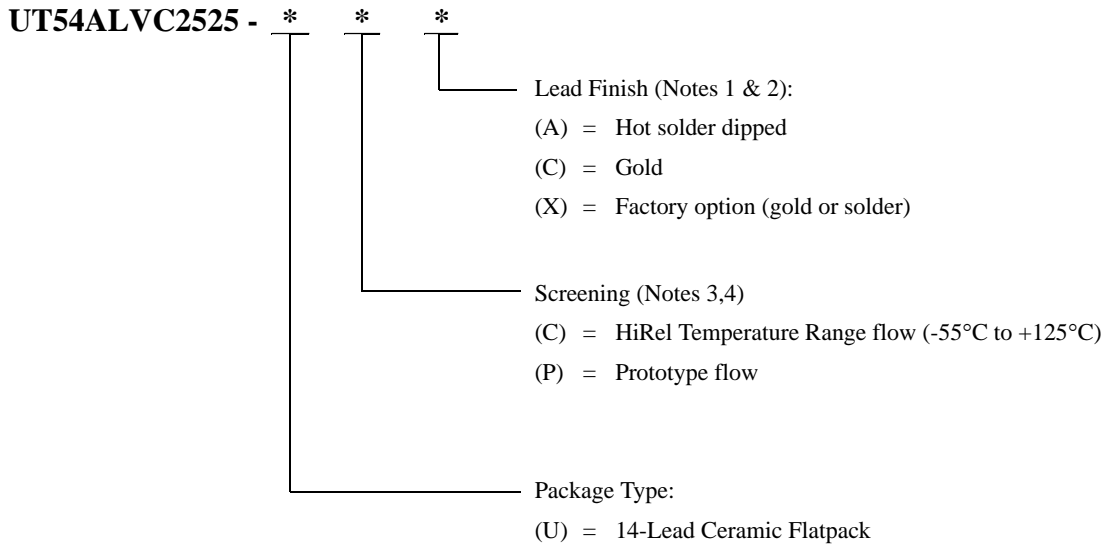

Notes:

1. Lead finish (A,C, or X) must be specified.
2. If an "X" is specified when ordering, then the part marking will match the lead finish and will be either "A" (solder) or "C" (gold).
3. Prototype flow per Aeroflex Manufacturing Flows Document. Tested at 25°C only. Lead finish is GOLD ONLY. Radiation neither tested nor guaranteed.
4. HiRel Temperature Range flow per Aeroflex Colorado Springs Manufacturing Flows Document. Devices are tested at -55°C, room temp, and 125°C. Radiation neither tested nor guaranteed.

UT54ALVC2525: SMD

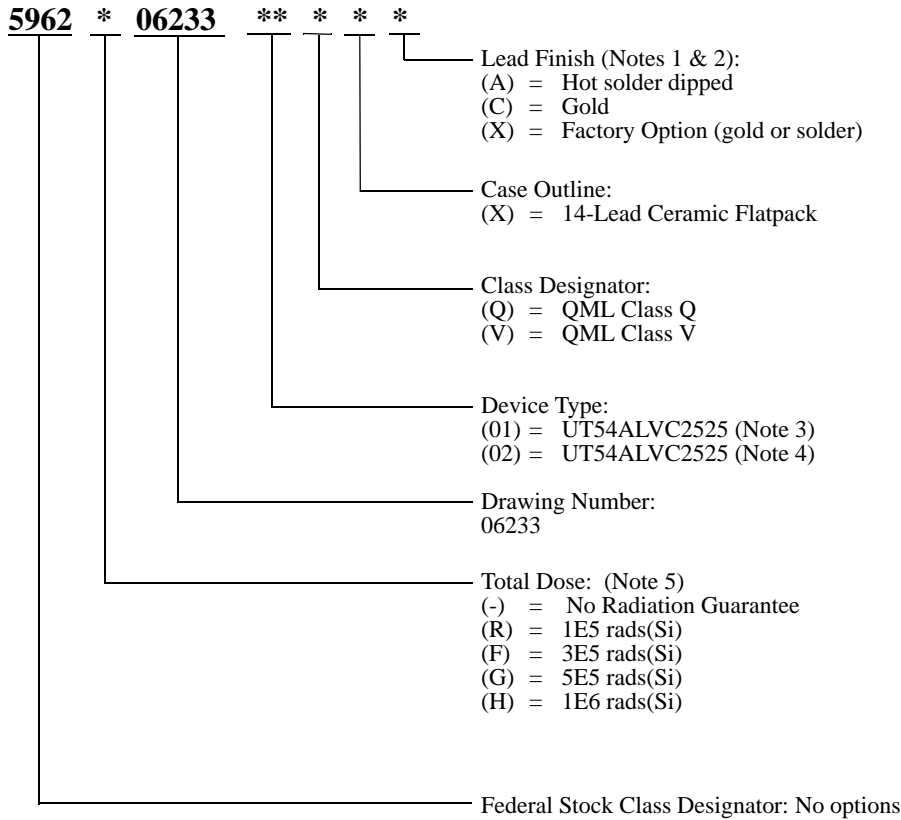

Notes:

1. Lead finish (A, C, or X) must be specified.
2. If an "X" is specified when ordering, part marking will match the lead finish and will be either "A" (solder) or "C" (gold)
3. Available to a maximum RHA level of H.
4. Available to a maximum RHA level of R. Device is irradiated at a dose rate = 50-300 rads(Si)/s in accordance with MIL-STD-883, Method 1019, Condition A, and is guaranteed to a maximum total dose specified. The effective dose rate after extended room temperature anneal = 1 rads(Si)/s per MIL-STD-883, Method 1019, Condition A, section 3.11.2. The total dose specification for these devices only applies to a low dose rate environment.
5. Total dose radiation must be specified when ordering. QML Q and QML V are not available without radiation hardening.

Aeroflex Colorado Springs - Datasheet Definition

Advanced Datasheet - Product In Development

Preliminary Datasheet - Shipping Prototype

Datasheet - Shipping QML & Reduced HiRel

The following United States (U.S.) Department of Commerce statement shall be applicable if these commodities, technology, or software are exported from the U.S.: These commodities, technology, or software were exported from the United States in accordance with the Export Administration Regulations. Diversion contrary to U.S. law is prohibited.

Cobham Semiconductor Solutions
4350 Centennial Blvd
Colorado Springs, CO 80907

The logo for Cobham, featuring the word "COBHAM" in a bold, italicized, white sans-serif font against a blue background.

E: info-ams@aeroflex.com
T: 800 645 8862

Aeroflex Colorado Springs Inc., dba Cobham Semiconductor Solutions, reserves the right to make changes to any products and services described herein at any time without notice. Consult Aeroflex or an authorized sales representative to verify that the information in this data sheet is current before using this product. Aeroflex does not assume any responsibility or liability arising out of the application or use of any product or service described herein, except as expressly agreed to in writing by Aeroflex; nor does the purchase, lease, or use of a product or service from Aeroflex convey a license under any patent rights, copyrights, trademark rights, or any other of the intellectual rights of Aeroflex or of third parties.

ATA SHEET REVISION HISTORY

REV	Revision Date	Description of Change	Author
1.0.0	2-16	Added Cobham datasheet template	BM