



パワーデバイス

# SiCパワーデバイス

## CONTENTS

- SiC-ショットキーバリアダイオード ..... P. B2
- SiC-MOSFET ..... P. B5
- フルSiCパワーモジュール ..... P. B7





B

SiC  
パワー  
デバイス





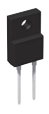

ISO/TS 16949 取得済み

## SiC-ショットキーバリアダイオード

## ● SiC-ショットキーバリアダイオード早見表

V <sub>RM</sub> (V)	I <sub>F</sub> (A)	端子挿入タイプ				面実装タイプ				
		 TO-220AC	 TO-220ACP	 TO-220FM	 TO-247	 TO-263AB (LPTL)				
650	6	SCS206AG SCS206AGHR	13 19 <b>New</b> SCS306AP	25	SCS206AM	28		SCS206AJ SCS206AJHR	1 7	
	8	SCS208AG SCS208AGHR	14 20 <b>New</b> SCS308AP	26	SCS208AM	29		SCS208AJ SCS208AJHR	2 8	
	10	SCS210AG SCS210AGHR	15 21 <b>New</b> SCS310AP	27	SCS210AM	30		SCS210AJ SCS210AJHR	3 9	
	12	SCS212AG SCS212AGHR	16 22		SCS212AM	31		SCS212AJ SCS212AJHR	4 10	
	15	SCS215AG SCS215AGHR	17 23		SCS215AM	32	SCS215AE	34	SCS215AJ SCS215AJHR	5 11
	20	SCS220AG SCS220AGHR	18 24		SCS220AM	33	SCS220AE SCS220AE2 SCS220AE2HR	35 36 39	SCS220AJ SCS220AJHR	6 12
	30						SCS230AE2 SCS230AE2HR	37 40		
	40						SCS240AE2 SCS240AE2HR	38 41		
1,200	5	SCS205KG SCS205KGHR	42 46							
	10	SCS210KG SCS210KGHR	43 47				SCS210KE2 SCS210KE2HR	50 54		
	15	SCS215KG SCS215KGHR	44 48							
	20	SCS220KG SCS220KGHR	45 49				SCS220KE2 SCS220KE2HR	51 55		
	30						<b>New</b> SCS230KE2 SCS230KE2AHR	52 56		
	40						<b>New</b> SCS240KE2 SCS240KE2AHR	53 57		

注) ( ) 内は ROHM/パッケージを示します。

SiC-ショットキーバリアダイオード												
早見表番号	品名	車載対応 (AEC-Q101※2)	絶対最大定格 (Ta=25°C)				電気的特性 (Ta=25°C)				パッケージ	等価回路図
			V <sub>RM</sub> (V)	V <sub>R</sub> (V)	I <sub>F</sub> (A)	I <sub>FSM</sub> (A) 50Hz, 1 $\mu$ s	V <sub>F</sub> (V) Typ.	I <sub>F</sub> (A)	I <sub>R</sub> ( $\mu$ A) Max.	V <sub>R</sub> (V)		
1	SCS206AJ	—	650	650	6	22	1.35	6	120	600	TO-263AB (LPTL)	
2	SCS208AJ	—	650	650	8	29	1.35	8	160	600		
3	SCS210AJ	—	650	650	10	38	1.35	10	200	600		
4	SCS212AJ	—	650	650	12	42	1.35	12	240	600		
5	SCS215AJ	—	650	650	15	52	1.35	15	300	600		
6	SCS220AJ	—	650	650	20	67	1.35	20	400	600		
7	SCS206AJHR	Yes	650	650	6	22	1.35	6	120	600		
8	SCS208AJHR	Yes	650	650	8	29	1.35	8	160	600		
9	SCS210AJHR	Yes	650	650	10	38	1.35	10	200	600		
10	SCS212AJHR	Yes	650	650	12	42	1.35	12	240	600		
11	SCS215AJHR	Yes	650	650	15	52	1.35	15	300	600		
12	SCS220AJHR	Yes	650	650	20	67	1.35	20	400	600		
13	SCS206AG	—	650	650	6	22	1.35	6	120	600	TO-220AC	
14	SCS208AG	—	650	650	8	29	1.35	8	160	600		
15	SCS210AG	—	650	650	10	38	1.35	10	200	600		
16	SCS212AG	—	650	650	12	42	1.35	12	240	600		
17	SCS215AG	—	650	650	15	52	1.35	15	300	600		
18	SCS220AG	—	650	650	20	67	1.35	20	400	600		
19	SCS206AGHR	Yes	650	650	6	22	1.35	6	120	600		
20	SCS208AGHR	Yes	650	650	8	29	1.35	8	160	600		
21	SCS210AGHR	Yes	650	650	10	38	1.35	10	200	600		
22	SCS212AGHR	Yes	650	650	12	42	1.35	12	240	600		
23	SCS215AGHR	Yes	650	650	15	52	1.35	15	300	600		
24	SCS220AGHR	Yes	650	650	20	67	1.35	20	400	600		
25	New SCS306AP	—	650	650	6	47	1.35	6	30	650	TO-220ACP	
26	New SCS308AP	—	650	650	8	67	1.35	8	40	650		
27	New SCS310AP	—	650	650	10	82	1.35	10	50	650		
28	SCS206AM	—	650	650	6	22	1.35	6	120	600	TO-220FM	
29	SCS208AM	—	650	650	8	29	1.35	8	160	600		
30	SCS210AM	—	650	650	10	38	1.35	10	200	600		
31	SCS212AM	—	650	650	12	42	1.35	12	240	600		
32	SCS215AM	—	650	650	15	52	1.35	15	300	600		
33	SCS220AM	—	650	650	20	67	1.35	20	400	600		
34	SCS215AE	—	650	650	15	52	1.35	15	300	600	TO-247	
35	SCS220AE	—	650	650	20	67	1.35	20	400	600		
36	SCS220AE2	—	650	650	10/20※1	38/76※1	1.35	10	200	600		
37	SCS230AE2	—	650	650	15/30※1	52/104※1	1.35	15	300	600		
38	SCS240AE2	—	650	650	20/40※1	67/135※1	1.35	20	400	600		
39	SCS220AE2HR	Yes	650	650	10/20※1	38/76※1	1.35	10	200	600		
40	SCS230AE2HR	Yes	650	650	15/30※1	52/104※1	1.35	15	300	600		
41	SCS240AE2HR	Yes	650	650	20/40※1	67/135※1	1.35	20	400	600		
42	SCS205KG	—	1,200	1,200	5	22	1.4	5	100	1,200	TO-220AC	
43	SCS210KG	—	1,200	1,200	10	42	1.4	10	200	1,200		
44	SCS215KG	—	1,200	1,200	15	62	1.4	15	300	1,200		
45	SCS220KG	—	1,200	1,200	20	78	1.4	20	400	1,200		
46	SCS205KGHR	Yes	1,200	1,200	5	22	1.4	5	100	1,200		
47	SCS210KGHR	Yes	1,200	1,200	10	42	1.4	10	200	1,200		
48	SCS215KGHR	Yes	1,200	1,200	15	62	1.4	15	300	1,200		
49	SCS220KGHR	Yes	1,200	1,200	20	78	1.4	20	400	1,200	TO-247	
50	SCS210KE2	—	1,200	1,200	5/10※1	22/45※1	1.4	5	100	1,200		
51	SCS220KE2	—	1,200	1,200	10/20※1	42/84※1	1.4	10	200	1,200		
52	SCS230KE2	—	1,200	1,200	15/30※1	62/124※1	1.4	15	300	1,200		
53	SCS240KE2	—	1,200	1,200	20/40※1	78/157※1	1.4	20	400	1,200		
54	SCS210KE2HR	Yes	1,200	1,200	5/10※1	22/45※1	1.4	5	100	1,200		
55	SCS220KE2HR	Yes	1,200	1,200	10/20※1	42/84※1	1.4	10	200	1,200		
56	New SCS230KE2AHR	Yes	1,200	1,200	15/30※1	62/124※1	1.4	15	300	1,200		
57	New SCS240KE2AHR	Yes	1,200	1,200	20/40※1	78/157※1	1.4	20	400	1,200		

注) ( ) 内は ROHM/パッケージを示します。

※1 (1端子/パッケージ) ※2 Rev.C

B

SiCパワーデバイス

## SiC-ショットキーバリアダイオード

## ●外形寸法図 (単位: mm)

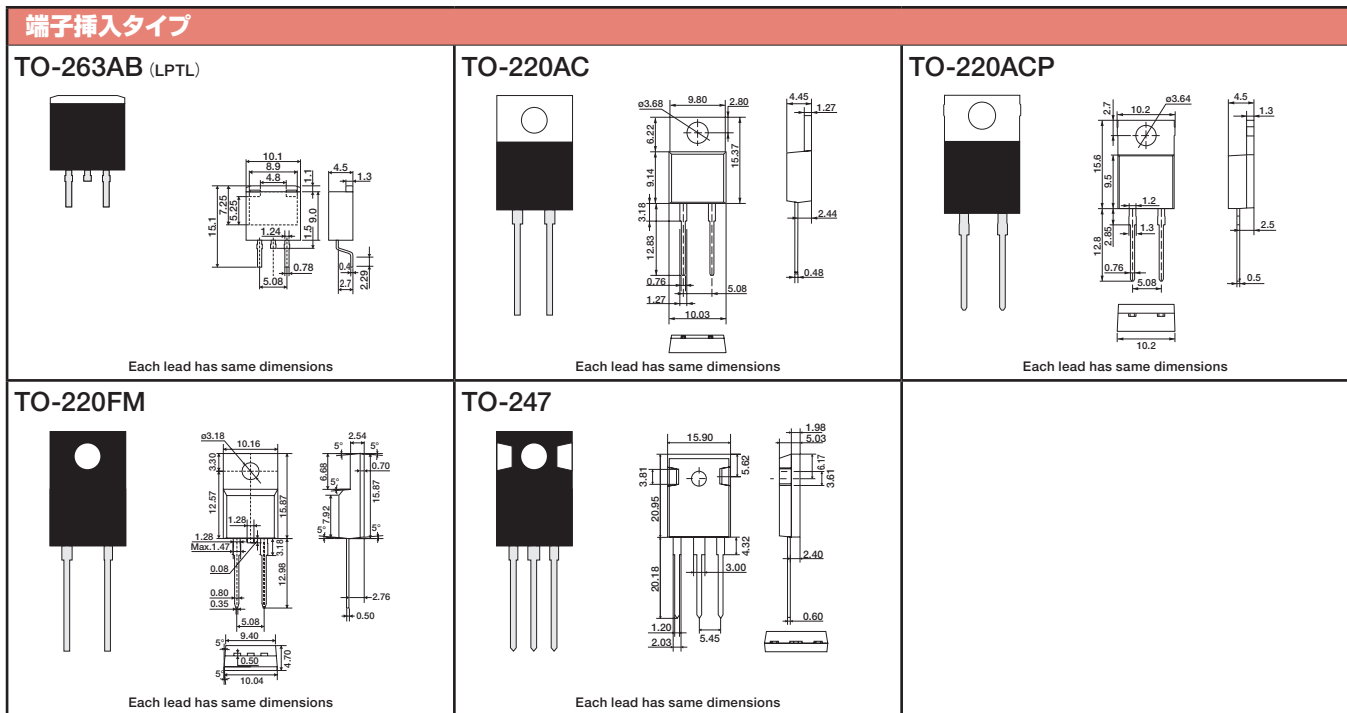

注) ( ) 内は ROHMパッケージを示します。

## ●形名の構成

●SBD (パッケージ品)の品名(基本形名)について

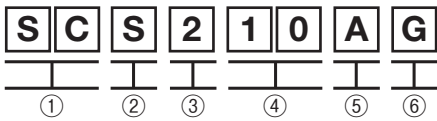

- ① SiC ディスクリットデバイス
- ② SBDを表す
- ③ 世代を表す
- ④ 定格電流 [アンペア表示]  
例 05 → 5A  
10 → 10A

- ⑤ 耐圧  
例 A → 650V  
K → 1200V
- ⑥ パッケージ  
例 E → TO-247  
E2 → TO-247 (Dual chip)  
G → TO-220AC  
P → TO-220ACP  
M → TO-220FM  
J → TO-263AB (LPTL)





## ●包装仕様

パッケージ	記号	包装仕様	基本発注単位 (pcs)
TO-263AB (LPTL)	TLL	エンボステープ	1000
TO-220AC	C	チューブ	50
TO-220ACP	C9	チューブ	50
TO-220FM	C	チューブ	50
TO-247	C	チューブ	30

注) ( ) 内は ROHMパッケージを示します。

# SiC-MOSFET

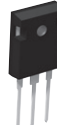
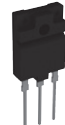
## ●SiC-MOSFET早見表

V <sub>DSS</sub> (V)	R <sub>Ds(on)</sub> (mΩ)	端子挿入タイプ				面実装タイプ	SiC SBD		
									
		TO-220AB	TO-247	TO-247N	TO-3PFM	TO-268-2L			
400	120	SCTMU001F (MUSIC SERIES) 24					—		
650	17			New SCT3017AL 1					
	22			New SCT3022AL 2					
	30			New SCT3030AL 3			—		
	60			New SCT3060AL 4					
	120	SCT2120AF 6			New SCT3120AL 5		—		
1,200	22			New SCT3022KL 7			—		
	30			New SCT3030KL 8			—		
	40			New SCT3040KL 9			—		
	80		SCT2080KE 13	New SCT3080KL 10				—	
			SCH2080KE 12					同梱	
	160		☆SCT2080KEAHR 14					—	
			SCT2160KE 15	New SCT3160KL 11				—	
			☆SCT2160KEAHR 16					—	
		280		SCT2280KE 17					—
				☆SCT2280KEAHR 18					—
450		SCT2450KE 19					—		
		☆SCT2450KEAHR 20					—		
1,700	1,150				New SCT2H12NZ 23	☆SCT2H12NY 21	—		
	750					☆SCT2750NY 22	—		

☆：開発中

## SiC-MOSFET

SWITCHING SERIES											
早見表番号	品名	車載対応 (AEC-Q101)	極性 (ch)	V <sub>DSS</sub> (V)	I <sub>D</sub> (A)	P <sub>D</sub> (W) (Tc=25°C)	R <sub>Ds(on)</sub> Typ. (mΩ)		Q <sub>g</sub> Typ. (nC)		パッケージ
							V <sub>GS</sub> =18V	V <sub>GS</sub> =18V	V <sub>GS</sub> =18V	駆動電圧 (V)	
1	New SCT3017AL	—	N	650	118	427	17	172	18	TO-247N	
2	New SCT3022AL	—	N	650	93	339	22	133	18		
3	New SCT3030AL	—	N	650	70	262	30	104	18		
4	New SCT3060AL	—	N	650	39	165	60	58	18		
5	New SCT3120AL	—	N	650	21	103	120	38	18		
6	SCT2120AF	—	N	650	29	165	120	61	18	TO-220AB	
7	New SCT3022KL	—	N	1,200	95	427	22	178	18	TO-247N	
8	New SCT3030KL	—	N	1,200	72	339	30	131	18		
9	New SCT3040KL	—	N	1,200	55	262	40	107	18		
10	New SCT3080KL	—	N	1,200	31	165	80	60	18		
11	New SCT3160KL	—	N	1,200	17	103	160	42	18		
12	SCH2080KE	—	N	1,200	40	262	80	106	18	TO-247	
13	SCT2080KE	—	N	1,200	40	262	80	106	18		
14	☆SCT2080KEAHR	Yes	N	1,200	40	262	80	106	18		
15	SCT2160KE	—	N	1,200	22	165	160	62	18		
16	☆SCT2160KEAHR	Yes	N	1,200	22	165	160	62	18		
17	SCT2280KE	—	N	1,200	14	108	280	35	18		
18	☆SCT2280KEAHR	Yes	N	1,200	14	108	280	35	18		
19	SCT2450KE	—	N	1,200	10	85	450	27	18	TO-268-2L	
20	☆SCT2450KEAHR	Yes	N	1,200	10	85	450	27	18		
21	☆SCT2H12NY	—	N	1,700	4	44	1,150	14	18		
22	☆SCT2750NY	—	N	1,700	5.9	57	750	17	18		
23	New SCT2H12NZ	—	N	1,700	3.7	35	1150	14	18	TO-3PFM	
MUSIC SERIES											
24	SCTMU001F	—	N	400	20	132	120	59	18	TO-220AB	

☆：開発中

## SiC-MOSFET

## ●外形寸法図 (単位: mm)

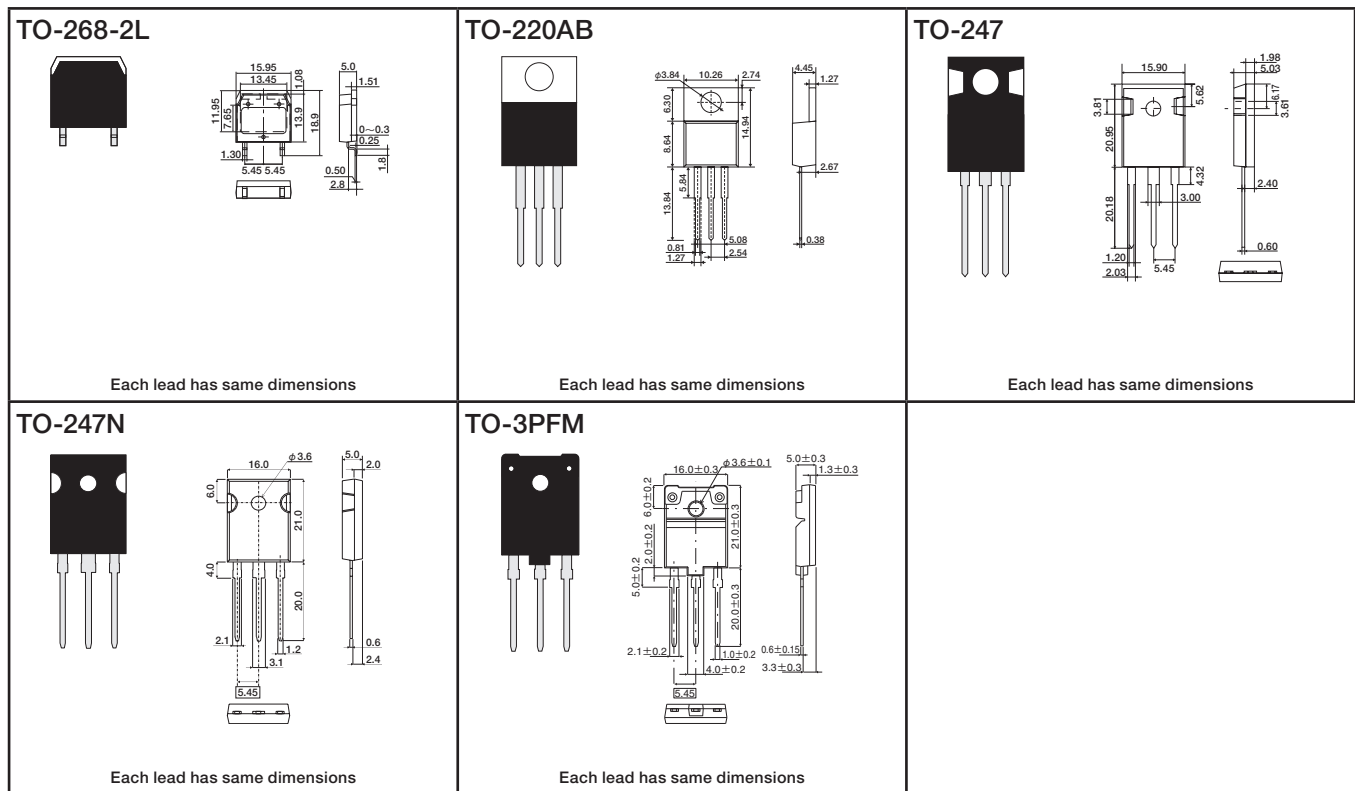

## ●内部回路図

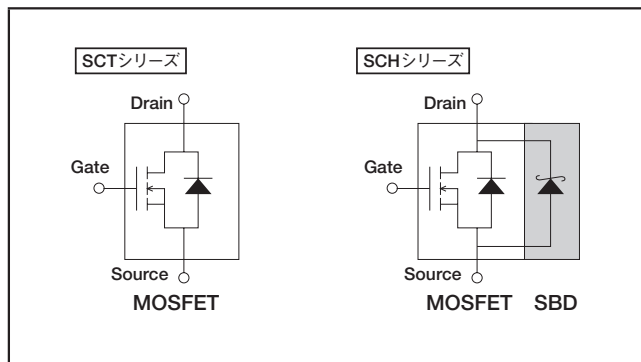

## ●形名の構成

●MOSFETの品名(基本形名)について

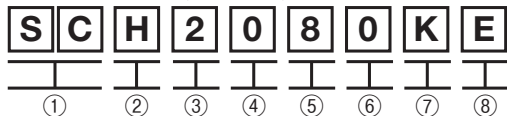

- ① SiC ディスクリットデバイス
- ② H → MOSFET+SBD同梱を表す  
T → MOSFET単体を表す
- ③ 世代を表す
- ④ } オン抵抗値 [mΩ表示]
- ⑤ } H12 = 1.2 Ω
- ⑥ }

- ⑦ 耐圧 A → 650V K → 1,200V  
N → 1,700V
- ⑧ パッケージ F → TO-220AB  
E → TO-247  
L → TO-247N  
Y → TO-268-2L  
Z → TO-3PFM

## ●包装仕様

パッケージ	記号	包装仕様	基本発注単位 (pcs)
TO-268-2L	TB	エンボステーブ	400
TO-220AB	C	チューブ	50
TO-247	C	チューブ	30
TO-247N	C11	チューブ	30
TO-3PFM	C11	チューブ	30

# フルSiCパワーモジュール

## ●フルSiCパワーモジュール早見表

V <sub>DSS</sub> (V)	R <sub>Ds (ON)</sub> (mΩ)	ケースタイプ	
		C type	E type
1,200	34	<b>New</b> BSM080D12P2C008	—
	20	BSM120D12P2C005	—
	12.8	BSM180D12P2C101	—
	10	BSM180D12P3C007	—
	7.3	—	BSM300D12P2E001

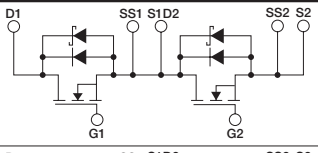
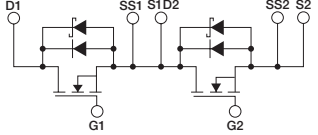
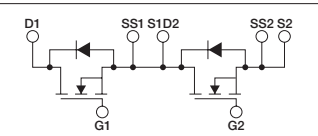
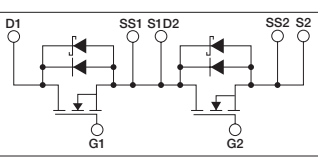
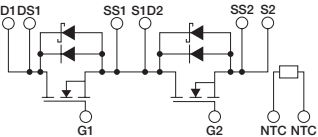
フルSiCパワーモジュール							
品名	絶対最大定格 (Ta=25°C)					パッケージ	内部回路図
	V <sub>DSS</sub> (V)	I <sub>D</sub> (A) [T <sub>C</sub> =60°C]	T <sub>J</sub> (°C)	T <sub>stg</sub> (°C)	Visol (V) AC 1Min.		
<b>New</b> BSM080D12P2C008	1,200	80	-40 ~ +175	-40 ~ +125	2,500	C type	
BSM120D12P2C005	1,200	120	-40 ~ +175	-40 ~ +125	2,500		
BSM180D12P2C101	1,200	180	-40 ~ +175	-40 ~ +125	2,500		
BSM180D12P3C007	1,200	180	-40 ~ +175	-40 ~ +125	2,500		
BSM300D12P2E001	1,200	300	-40 ~ +175	-40 ~ +125	2,500	E type	

B  
SiC  
パワー  
デバイス

## フルSiCパワーモジュール

## ●外形寸法図(単位:mm)

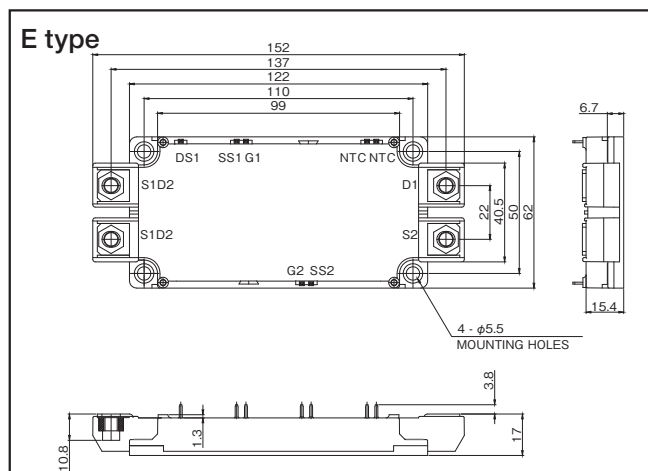
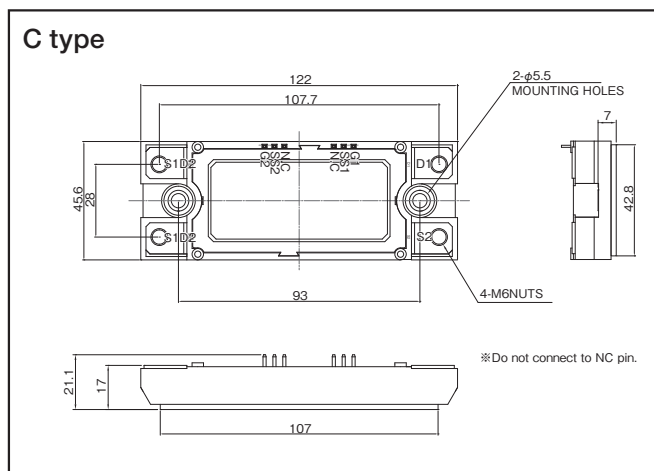

## ●形名の構成

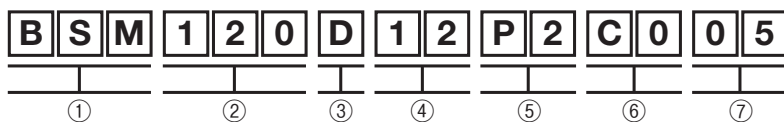

- ① SiC パワーモジュール
- ② 定格電流
- ③ 内部回路  
D…ハーフブリッジ  
C…チョッパ
- ④ 耐圧  
例 12 → 1200V
- ⑤ デバイスタイプ  
P2…第二世代SiC-MOS使用  
P3…第三世代SiC-MOS使用
- ⑥ ケースタイプ
- ⑦ 追番