

GLDM-5-520 Laser Module

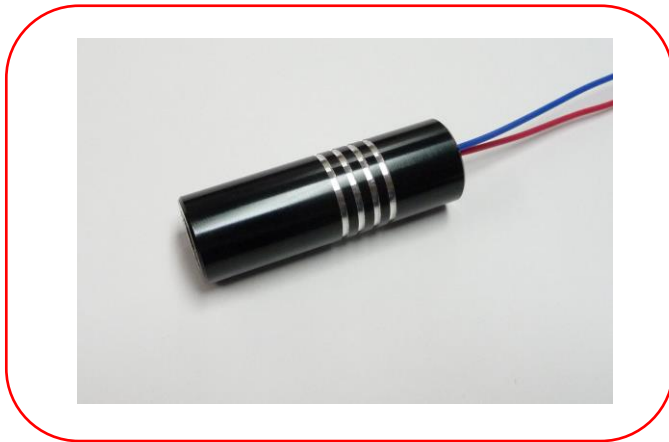

Features

- Wide operating temperature range (-15 to +60C)
- Instant laser on
- Stable output power (APC Driver)
- Compact size (dia. 16mm x 50mm long)
- Ideal for use over long distances
- Low beam divergence <0.3mrad
- Can be used during day or night
- Variable focus adjustment
- Available with range of line generators
- Suitable for outdoor and indoor use
- Ideal for visual alignment applications

OPTICAL PARAMETERS		
Wavelength	520nm	± 1.0nm
Available Powers (Custom power settings are available, some limitations may be present)	1mW (<1mW)	Class 2
	3mW (<3mW)	Class 3R
	5mW (<5mW)	Class 3R
	10mW	Class 3B
	15mW	Class 3B
Beam Size @ 10m (1/e²) / shape	6mm diameter – circularity > 0.90	
Beam Divergence	<0.3mrad	
Power Stability	± 5%, @ constant temperature over 2 hours	
Beam Pointing Stability	± 50µrad, @ 25°C over 2 hours	
Residual IR	0%	

ELECTRICAL PARAMETERS	
Laser Operating Driver	APC
Operating voltage	7V– 8VDC (V.Reg)
Typical Operating Current	<150mA

This product is registered with the FDA in accordance with 21 CFR 1040.10(a)(3)(I) and is compliant with European, and Australia/New Zealand laser safety standards 73/23/EEC - 98/37/EG, 89/336/EEC, EN 50081-1, EN-31252, EN-31252, EN 55022, EN 60825-1 and AS/NZS 2211:1997. The complete laser product manufacturer must supply adequate instructions for installation and servicing of this product. This is not a removable laser system. This product is designed solely as a component in an electronic product and therefore does not comply with the requirements of 21 CFR 1040.10 and 1040.11 for complete laser products. Avoid direct eye exposure to the beam.

GLDM-5-520 Laser Module



MECHANICAL/ENVIRONMENTAL PARAMETERS	
Mechanical / Optical Alignment	< 5mm @ 3m
Operating temperature	-15 – +60 °C
Storage Temperature	-40 – +80 °C
Operating Humidity	5% - 85% R.H.
Shock	1000g, 1ms, 6 shock
Vibration	20 – 2000Hz, 0.02g ² /Hz
Expected Lifetime (MTTF)	>5000 hrs
Physical Dimensions	diameter 16mm x 50mm
Optics	Glass lens

Line Generator Options

Product Description	Line Generator Fan Angle
L10	10 degrees
L20	20 degrees
L30	30 degrees
L45	45 degrees
ULG30	30 degrees
ULG60	60 degrees
ULG90	90 degrees
CH	Cross Hair Generator

Determining Laser Specifications from part number

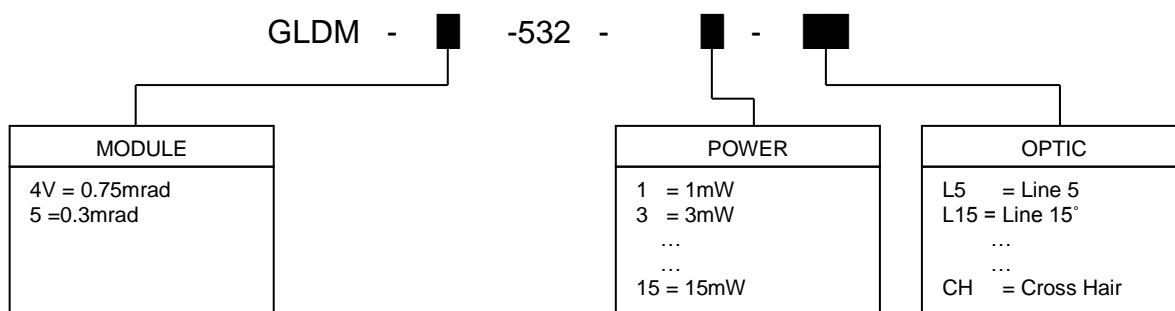

Other output powers are available as per customer request. Contact LasereX for further details.

This product is registered with the FDA in accordance with 21 CFR 1040.10(a)(3)(I) and is compliant with European, and Australia/New Zealand laser safety standards 73/23/EEC - 98/37/EG, 89/336/EEC, EN 50081-1, EN-31252, EN-31252, EN 55022, EN 60825-1 and AS/NZS 2211:1997. The complete laser product manufacturer must supply adequate instructions for installation and servicing of this product. This is not a removable laser system. This product is designed solely as a component in an electronic product and therefore does not comply with the requirements of 21 CFR 1040.10 and 1040.11 for complete laser products. Avoid direct eye exposure to the beam.