

STRADA Lens Guide



Contents

- STRADA lens types 3
 - Symmetric 3
 - Asymmetric 4
 - STRADA-T 4
 - STRADA-SQ 4
 - STRADA-F 5
- STRADA modules 6
 - STRADA 2x2 6
 - STRADA 6x1 7
- Mixing STRADA lenses 8
- IESNA type classification 9
- STRADA lens arrangement 10
- Fastening and positioning methods 11
 - Positioning 11
 - Positioning pins 11
 - External positioning 11
 - Fastening 12
 - Tape 12
 - Screws 12
 - Glue 12
- Glare reduction 13
 - STRADA lens combination 13
 - Glare shielding 13
 - Flat glass cover 13
- Environmental sealing 14
 - Protective glass cover 14
 - Sealing adhesives 14
 - Maintenance and cleaning 14
 - Damage to optical components 14
 - Weather resistant materials 14
- Technical support 15
 - Mechanical 3D models & 2D drawings 15
 - Photometric files 15
 - Near field ray data 15
 - Simulation support 15

STRADA lens types

STRADA lenses, originally designed for street lighting applications, are suitable for many other applications as well. Like all LEDiL products STRADA lenses are optimized for specific LED types and have optimal light distribution and over 90% optical efficiency. Some STRADA lenses can also be used with other LED types with a small sacrifice in light distribution and optical efficiency. STRADA lenses designated for roadway lighting have batwing light distribution for better performance.

Symmetric

Symmetric STRADA lenses were the first lenses from LEDiL designed especially for street lighting applications. On street lighting setups, symmetrical light distribution requires a mounting boom and tilt in the lamp head. This makes symmetrical STRADA lenses ideal for traditional street light replacement. All symmetrical STRADA lenses have the standard 20mm x 16mm STRADA footprint.

STRADA-A

STRADA-A lenses were the first street lighting lenses designed by LEDiL. STRADA-A has a light distribution that works best when the road is narrower than the height of the pole and the spacing is four times the height of the pole.

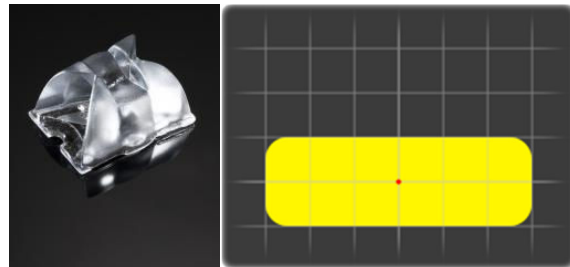

STRADA-B and STRADA-DN

STRADA-B and STRADA-DN lenses have a light distribution that is similar to normal fluorescent luminaires and has its uses on many indoor and outdoor applications. STRADA-B works best when the road is narrower than the height of the pole. STRADA-B performance is better when combined with STRADA-DW or STRADA-A.

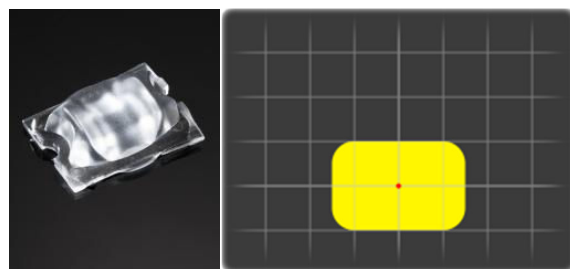

STRADA-C

STRADA-C has a rotationally symmetrical batwing distribution. STRADA-C can be used on street lighting applications where the STRADA-B is not wide enough.

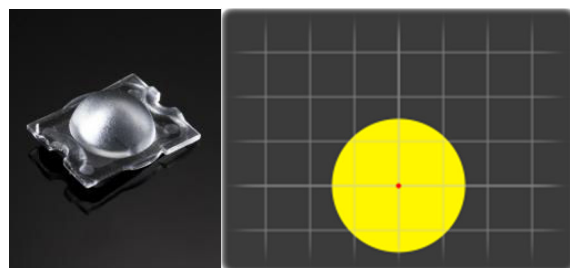

STRADA-DW

STRADA-DW is a two way side emitter that has only limited use on its own. STRADA-DW works best when the road is narrower than the height of the pole and the spacing is four times the height of the pole and when combined with STRADA-B or STRADA-C.

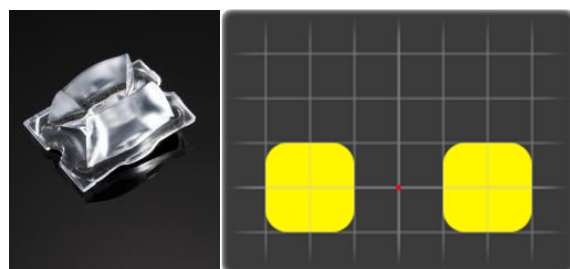

Asymmetric

Asymmetric STRADA lenses are symmetrical on 0-180 axis and asymmetrical on 90-270 axis. The asymmetric design helps to direct more light on the street side without the need for tilt on the lamp head. Asymmetric beam patterns serve to reduce the uplight of street light setups as the lamp head doesn't need to be tilted. Elimination of tilted lamp heads contributes to less uplight and, often, less glare.

STRADA-T

Our first asymmetric lens design. Designed to work on street setups where the road width is about the same as the pole height of the luminaire. STRADA-T lenses have the standard 20mm x 16mm STRADA footprint.

STRADA-T-DN

STRADA-T-DN is an asymmetric version of the STRADA-B. Best performance on street lighting setups can be achieved when combined with STRADA-T-DW.

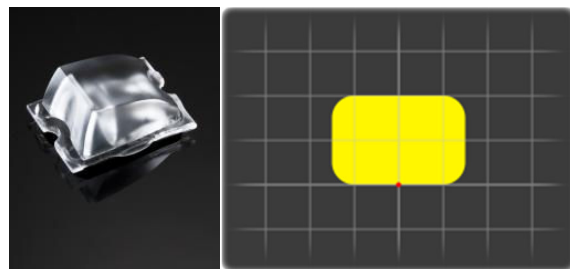

STRADA-T-DW

STRADA-T-DW is an asymmetric version of the STRADA-DW. Best performance on street lighting setups can be achieved when combined with STRADA-T-DN.

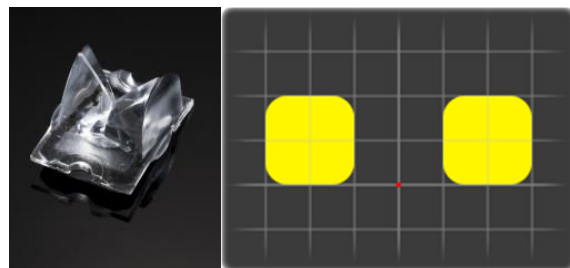

STRADA-SQ

STRADA-SQ series have lenses with asymmetric light distribution and 1" (25.4mm) square footprint. There is more room on the base for applying sealing adhesive without affecting the optical performance of the lenses.

STRADA-SQ-T-DN

STRADA-SQ-T-DN has similar light distribution and performance as STRADA-T-DN.

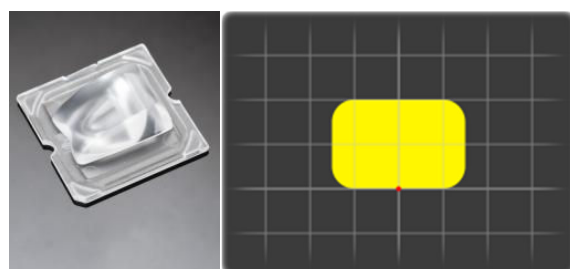

STRADA-SQ-T-DW

STRADA-SQ-T-DW has similar light distribution and performance as STRADA-T-DW.

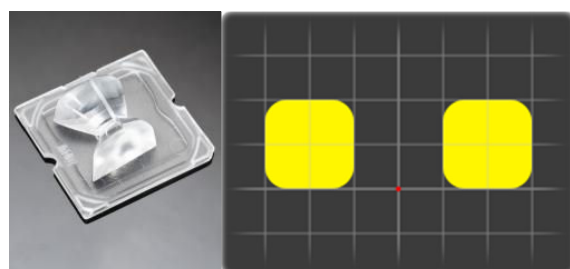

STRADA-SQ-T-DW-US

STRADA-SQ-T-DW-US is a wider version of STRADA-SQ-T-DW and is designed for extremely long pole distances over 6 times the height of the pole. Extremely wide design means that there are some problems with glare especially on high power luminaires. Glare reduction needs to be taken into consideration as explained later in this document.

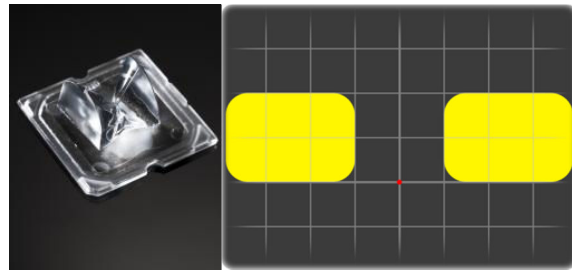

STRADA-SQ-A-T

STRADA-SQ-A-T lenses are designed for roads that are narrower than the height of the pole. Pole distance should be about 4 times the height of the pole. Light distribution is similar to STRADA-A, but with an asymmetric design so there is no need to tilt the lamp head.

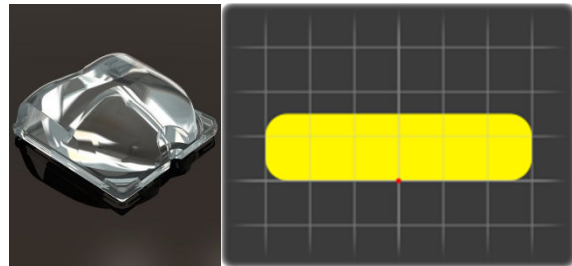

STRADA-F

STRADA-F lenses have an asymmetric design with strong forward throw high intensity peak. STRADA-F lenses work best on street lighting applications with street width twice the height of the mounted luminaire. STRADA-F lenses can also be used in applications where other STRADA lenses are hard to use such as odd-shaped parking lots. STRADA-F lenses have the standard 20mm x 16mm STRADA footprint.

STRADA-FT

STRADA-FT is a narrow version of the forward throwing STRADA series. STRADA-FT doesn't perform well on its own on street lighting setups. Performance is best in applications that need modularity from the design such as odd shaped parking lots.

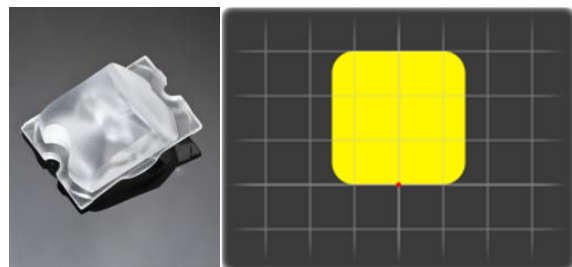

STRADA-FW

STRADA-FW is wider version of the forward throwing STRADA series. STRADA-FW can illuminate wide areas and performs well on road lighting setups with at least twice as wide street as the height of the pole. The pole distance can be 4 times the height of the pole.

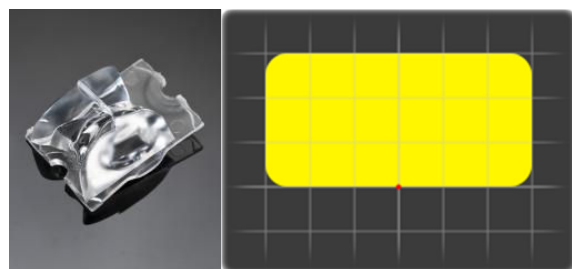

STRADA modules

STRADA modules have multiple lenses in a single array. STRADA lens modules are designed to be more cost effective than single lenses. Lens cost per LED is lower with lens modules and assembly and sealing of the fixture is also much simpler with lens modules.

STRADA 2x2

STRADA 2x2 modules have four lenses arranged in two rows. 2x2 lens design and 1" (25.4mm) spacing between the LEDs makes PCB design easier.

STRADA-2x2-A-T

STRADA-2x2-A-T has similar light distribution as STRADA-SQ-A-T and is designed to work on roads that are narrower than the height of the pole and when the spacing is four times the height of the pole. STRADA-2x2-A-T has an asymmetric design so it can be used without tilting the lamp head.

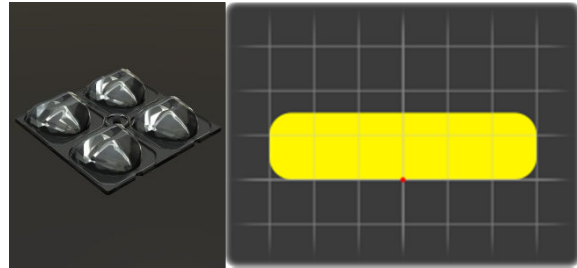

STRADA-2x2-DNW

STRADA-2x2-DNW is designed for roads where the pole height and the roadway width are similar. STRADA-2x2-DNW has an asymmetric design which often negates the need for tilting of the lamp head.

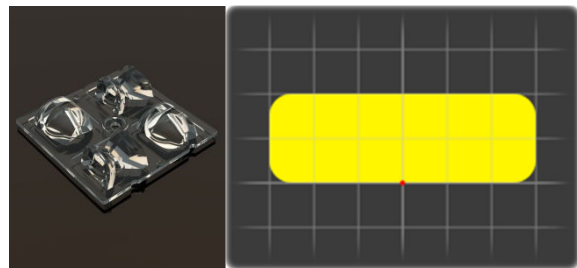

STRADA-2x2-DWC

STRADA-2x2-DWC is designed for roads with longer pole distances. It can be used in street lighting setups where the pole distance is six times the pole height. STRADA-2x2-DWC has an asymmetric design which often negates the need for tilting of the lamp head.

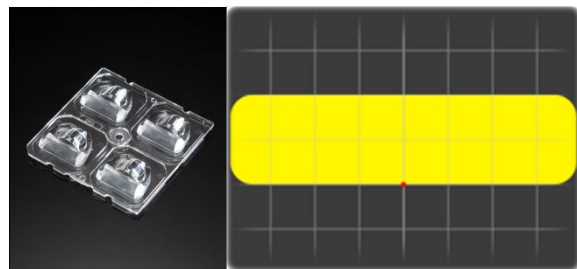

STRADA 6x1

STRADA 6x1 modules have six lenses in a linear array. The spacing between the LEDs in the row is 20mm so 6x1 modules can be used with the same PCB design as single STRADA lenses. Minimum side-to-side spacing is 1" (25.4mm).

STRADA-T-6x1-DNW

STRADA-T-6x1-DNW is ideal for European ME standards and can be used to achieve other street lighting standards. Exceptionally good control over longitudinal uniformity means that even ME1 is easy to achieve. Street width should be close to the height of the pole and pole distance can be about 4 times the height of the pole.

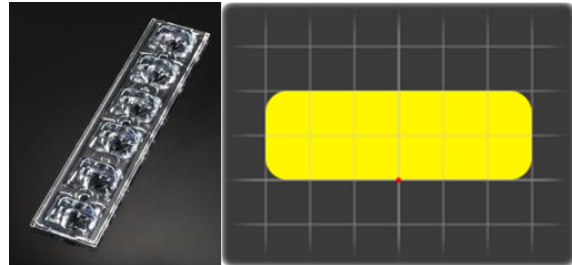

STRADA-T-6x1-DWC

STRADA-T-6x1 -DWC is optically close to the STRADA-2x2-DWC and works well on longer pole distances of up to 6 times the height of the pole.

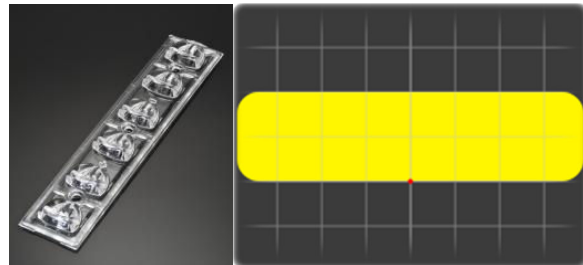

Mixing STRADA lenses

STRADA lenses are designed to be versatile to allow the development of fixtures for all types of roadway lighting applications. The best results are often achieved when using a combination of STRADA lens types. STRADA-A, STRADA-SQ-A-T and STRADA modules are designed to work on their own, but can still be used with other STRADA lenses. Below are typical examples of different STRADA lens combinations; STRADA lenses can also be used in many different combinations not listed.

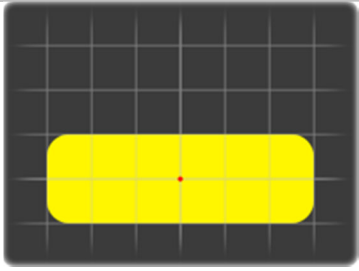
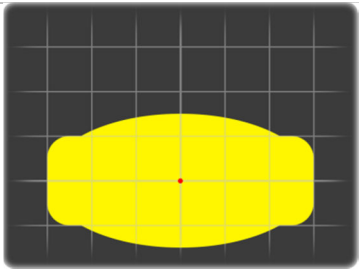
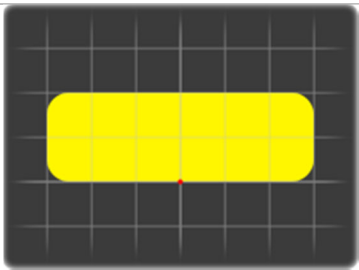
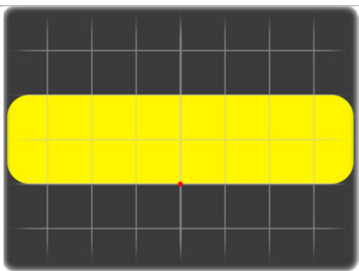
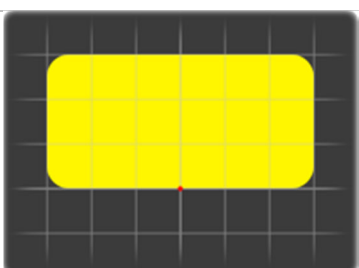
Lens combinations	Light distribution pattern
STRADA-A + STRADA-B STRADA-DW + STRADA-B STRADA-A + STRADA-DN STRADA-DW + STRADA-DN	
STRADA-A + STRADA-C STRADA-DW + STRADA-C	
STRADA-T-DN + STRADA-T-DW STRADA-SQ-T-DN + STRADA-SQ-T-DW	
STRADA-SQ-T-DN + STRADA-SQ-T-DW- US	
STRADA-FT + STRADA-FW	

IESNA type classification

IESNA Type	Single lenses	Lens combinations
Type I	STRADA-A STRADA-B	STRADA-A + STRADA-B STRADA-A + STRADA-C STRADA-DW + STRADA-B STRADA-DW + STRADA-C
Type II	STRADA-2x2-A-T STRADA-SQ-A-T STRADA-T-6x1-DNW STRADA-A * STRADA-B *	STRADA-A + STRADA-B * STRADA-A + STRADA-C * STRADA-DW + STRADA-B * STRADA-DW + STRADA-C *
Type III	STRADA-2x2-DWC STRADA-T-6x1-DWC STRADA-2x2-DNW	STRADA-T-DN + STRADA-T-DW STRADA-SQ-T-DN + STRADA-SQ-T-DW
Type IV	STRADA-FT STRADA-FW	STRADA-FT + STRADA-FW STRADA-SQ-T-DN + STRADA-SQ-T-DW-US
Type V	STRADA-C	Multidirectional STRADA-FT ** Multidirectional STRADA-T-DN **

* Symmetrical STRADA lenses fall into Type II category when the PCB is tilted about 10°.

** Designs where STRADA-T-DN and STRADA-FT lenses are assembled to face multiple directions can create Type V square or round light distribution. 4 directional assembly of STRADA-T-DN creates a square pattern while 6 directional assembly of STRADA-T-DN or STRADA-FT creates a round pattern.



STRADA lens arrangement

STRADA lenses have wide emitting angles and, in order to minimize interference between adjacent lenses, the PCB should be designed to minimize interference between adjacent lenses. STRADA lenses arranged too closely to one another can result in up to 25% light loss. To minimize this shading effect there are some general rules for lens arrangement.

All single STRADA lenses can be arranged into two categories when trying to determine the minimum spacing between two lens rows. Some STRADA lenses have wider light distribution than others and, therefore, have a higher chance of being shaded by adjacent lenses. Wider STRADA lenses also have a higher profile than narrower STRADA lenses.

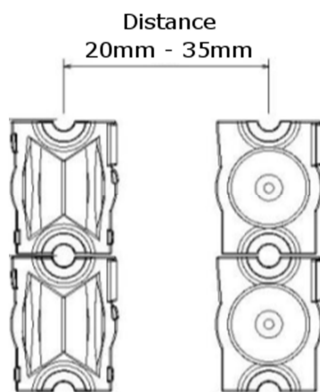

STRADA lenses with wide angles	STRADA lenses with narrow angles
STRADA-A	STRADA-B (STRADA-DN)
STRADA-DW	STRADA-C
STRADA-T-DW	STRADA-T-DN
STRADA-FW	STRADA-FT

Lens combination	Minimum row spacing
Wide lens next to a wide lens	35mm
Wide lens next to a narrow lens	25mm
Narrow lens next to a narrow lens	20mm

STRADA-SQ lenses and STRADA lens modules are designed to be placed right next to each other without having noticeable problems with shading. STRADA-SQ-T-DW and STRADA-SQ-T-DW-US lenses are the only exception to this rule and should not be placed next to each other if possible.

Consult LEDiL for further details about light loss calculations between lenses where minimum row spacing cannot be achieved.

Fastening and positioning methods

Positioning

Correct positioning between the LED and the lens is an important part of the design as it ensures that the lens performs as designed. Poor positioning has a big impact on the optical efficiency and light distribution of the lens and on the performance of the whole luminaire.

STRADA lenses are designed optically to accommodate 0.3mm offset on X and Y-axis and 0.1mm offset on Z-axis without significant effect on the optical performance. 0.3mm is usually the worst case offset from tolerance stacking of the LED, PCB and lens assembly. Multiple tolerance offsets rarely occurs in exactly the same direction and the light distribution is often balanced on luminaires consisting of multiple LEDs.

Positioning pins

Most STRADA lenses and lens modules have positioning pins to help align the lens with the LED. The PCB needs to be designed so that there are holes for the pins at the correct locations. With correct PCB design the positioning pins guide the lenses into right position.



External positioning

LEDiL provides some STRADA lenses without positioning pins for use with automated assembly equipment. These “externally positioned” lenses can also be specified in tape & reel packaging. Look for “EP” at the end of the order code to indicate external positioning STRADA lenses.



Other STRADA lenses designed without positioning pins are designed to fit tightly around specific LED bases. These lenses are ideal when PCB design accuracy is in question, as correct alignment of the lens is assured during placement over the LED. Consult LEDiL for recommendations about use of non-qualified LEDs with this lens style.

Fastening

Tape

The quickest method for fastening STRADA lenses is pre-installed automotive-grade polyurethane tape. The tape is strong enough to hold on its own in most applications. All single STRADA lenses can be ordered with a pre-installed tape option. Tape can also be used as a placement aid prior to a final fastening process; for example, in high-vibration applications.

There are number of factors that have negative effect on the performance of the pre-installed tape supplied with STRADA lenses. One should always follow the instructions found on the tape manual and test to ensure that the tape is suitable for the target application.

http://ledil.com/sites/default/files/Documents/Technical/Installation/20110406_DataSheet_TAPE.pdf

Screws

Screws are the most reliable option for fastening STRADA products and that is why all standard STRADA products have holes for screws. Screws can be used in addition with pre-installed tape.

All STRADA products are made from PMMA, a brittle material that can break under pressure. One should never tighten the screws more than is needed to hold the lens in place, as excessive force can cause cracks on the material that impact optical performance and proper sealing of the lens.

Glue

Glue is a permanent solution for fastening the STRADA products. Glue also helps to create a better seal on the STRADA products.

Different glue types can damage the LED, which can lead to rapid decrease on lumen output. One should always perform proper testing before deciding which glue to use in production.

http://ledil.com/sites/default/files/Documents/Technical/Installation/20110406_DataSheet_GLUES.pdf

Glare reduction

STRADA lenses are designed for outdoor applications where high light intensities are needed at extremely wide angles. Glare is a result from light between 75° and 90° planes and the highest intensity spikes of wide STRADA lenses often needs to be as close to these limits as possible. Good cutoff is amongst the targets when the lenses are designed, but sometimes it is difficult to get good cutoff with the lens design without affecting the light distribution and efficiency of the lens.

STRADA lenses are measured with only an LED installed on a PCB. Because there is no cutoff shielding installed during the measurement of the lenses, a small percentage of light that comes through the base of the lens is measured. This means that the measurements reflect the worst case scenario with glare when lenses are used without any shielding.

STRADA lens combination

Single STRADA lenses are usually used in combinations of two or more different lens types. Normally one lens has wider light distribution than the other and is more prone to cause glare. For this reason it is often good to keep the amount of the lenses with wider light distribution as low as possible without decreasing the overall performance of the luminaire.

Glare shielding

The easiest way to reduce glare in luminaire design is to merge the PCB inside the luminaire casing in a way that the lenses are not visible when viewed from the side. This kind of design blocks all the light at the 90° plane and also some light on the 75°- 90° planes depending on the depth of the casing and position of the PCB.

It is often not efficient to simply block the light on wider angles as this reduces the performance of the luminaire. Sloped walls with high reflection help to reduce the glare without reducing the efficiency of the luminaire. Higher walls allow more control over the cutoff but have more effect on the light distribution.

LEDiL's application engineering team can assist in the design of side walls and recommended position of the PCB in the luminaire casing.

Environmental sealing

Protective glass cover

The easiest way to seal a luminaire with STRADA lenses is to use “tertiary optics” such as a flat cover. This kind of solution always loses some light and affects the light distribution pattern of the STRADA lenses. With a flat cover light losses are around 10% depending on the material. Most of the lost light is at wider angles, which has a net benefit of also reducing glare. This means that the lumen output, however, needs to be higher and there needs to be a higher proportion of wide-emitting lenses when compared to a solution without a protective cover. LEDiL can advise on the shape of a rounded cover, which helps to reduce light loss, but does have some effect on the light distribution pattern.

Sealing adhesives

Luminaires can also be sealed without using a protective cover. By adding sealing adhesive around the lenses it is possible to seal the luminaire to IP66. Sealing adhesive does not contribute to light loss and the intended optical pattern is unchanged. It is possible to get over 90% optical efficiency for the whole luminaire with STRADA lenses when using sealing adhesives.

http://www.ledil.com/sites/default/files/Documents/Technical/Installation/20110406_DataSheet_Potting.pdf

Maintenance and cleaning

Street lighting luminaires are used in conditions where the luminaire is exposed to dust and other debris that can accumulate on the optical surfaces and the optical surface should be cleaned regularly to ensure consistent performance. Most STRADA modules are designed to have simple outer surfaces structures that can be cleaned almost as easily as a flat cover. Most STRADA lenses are designed to be cleaned by water spray or with a sponge. STRADA-2x2-DNW has a more complex optical surface that may require extra care in the cleaning process.

Cleaning detergents can contain chemicals that can damage the lens material and this possibility needs to be taken into account when choosing a suitable detergent.

Damage to optical components

STRADA lenses are molded from PMMA, a material with outstanding UV resistance but with less impact resistance and thermal capability than polycarbonate. Improper handling can damage the optical surfaces of STRADA lenses when there is no protective cover on the luminaire. To reduce the chance of damaging the optical components on the luminaire it is good to design the luminaire casing so that the luminaire will never rest on its optical components.

We have performed internal tests to estimate the impact forces our STRADA lenses can withstand. Impact resistance of STRADA lenses made from PMMA is usually near 0.5J, which means that most lenses should pass IK03 tests. STRADA lenses made from polycarbonate have higher impact resistance and could reach up to 5J in impact force, which means that lenses made from polycarbonate should pass IK08 tests. Polycarbonate does not offer the UV resistance of PMMA and so it is recommended that a tertiary cover treated with a UV-resistant coating is used when polycarbonate lenses are specified for outdoor applications.

Weather resistant materials

The PMMA material used by LEDiL is optical grade and has outstanding properties against weathering when compared to untreated polycarbonates. PMMA can withstand extreme outdoor temperatures without any changes on optical properties. The material is also remarkably stable against UV radiation and should remain stable for the life of the fixture. While there is also UV-resistant polycarbonate available on the market, this material has a much higher cost than PMMA and does not offer the outstanding optical performance of PMMA.

Technical support

Mechanical 3D models and 2D drawings

Mechanical 3D models and 2D drawings are available for LEDiL's entire product line. 2D drawings contain all the mechanical measurements necessary for PCB and luminaire design. 3D models can be used to aid the design process as problems in fitting are easily detected with CAD software.

All the surfaces on mechanical 3D models and 2D drawings have been simplified and do not contain any optical information. Performing optical simulations with LED ray data and a mechanical lens model will give false information.

Photometric files

Photometric files, also known as IES or EULUMDAT files, are an important tool for deciding the optics that work best on a project. Photometric files contain the angular light distribution information from the LED/lens combination and are intended for accurate simulations.

Many of the available photometric files have been measured in our lab with production components, but we also supply simulated files when measurements are not available. Simulated files correlate closely to measured data and give an accurate estimate of optical performance.

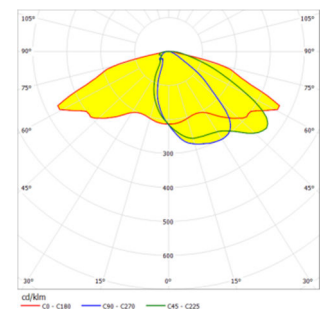

Near field ray data

Near field ray data files contain position and angular information of a fixed number of light rays and can be used to accurately simulate the light distribution in a smaller scale. Near field ray data is useful when trying to estimate the effects of the luminaire design in lens performance.

Near field data files are available for almost all LED and lens combinations on request. Due to the huge file sizes, the numbers of rays are normally limited to 100k rays.

Mechanical 3D models can be used when determining the position as 3D models share the same coordinates with the ray data files we create. The rays start about 0.1mm from the 3D model surface.

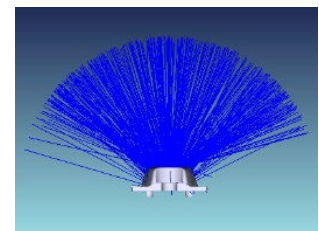

Ray data files are currently available only in ZEMAX format.

Simulation support

LEDiL understands that deep knowledge of optics and luminaire performance is something gained through experience and over time. Many of our customers require some level of assistance in lens selection, lens placement and attachment methods, sealing methods and more. Our motto is "learning by doing" and we have an Applications Engineering department available to provide design assistance when needed.

In addition, we are able to provide simulation of luminaire performance for luminaires designed with LEDiL optics. We have sales contacts located in key markets around the globe that are able to facilitate discussion and put our customers in touch with an Applications Engineer when a deeper level of technical assistance is required.