

L0402 Tight Tolerance



RF Inductor

GENERAL DESCRIPTION ITF TECHNOLOGY

The L0402 LGA Inductor is based on thin-film multilayer technology. The technology provides a miniature part with excellent high frequency performance and rugged construction for reliable automatic assembly.

APPLICATIONS

- Mobile Communications
- Satellite TV Receivers
- GPS
- Vehicle Location Systems
- Wireless LAN's
- Filters
- Matching Networks

LAND GRID ARRAY ADVANTAGES

- Inherent Low Profile
- Self Alignment during Reflow
- Excellent Solderability
- Low Parasitics
- Better Heat Dissipation

DIMENSIONS: (Bottom View)

millimeters (inches)

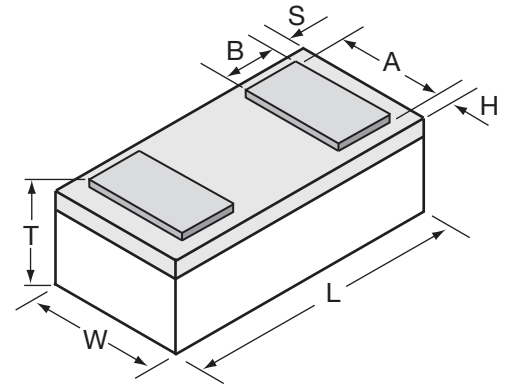

| | |
|---|----------------------------|
| L | 1.00±0.10 (0.039±0.004) |
| W | 0.58±0.07 (0.023±0.003) |
| T | 0.35±0.10 (0.014±0.004) |

| | |
|---|-----------------------------|
| A | 0.48±0.05 (0.019±0.002) |
| B | 0.17±0.05 (0.007±0.002) |
| S | 0.064±0.05 (0.003±0.002) |

HOW TO ORDER



P/N Example: **L04023R3BHNTTR**



QUALITY INSPECTION

Finished parts are 100% tested for electrical parameters and visual characteristics. Each production lot is evaluated on a sample basis for:

- Static Humidity: 85°C, 85% RH, 160 hours
- Endurance: 125°C, I_R, 4 hours

TERMINATION

Nickel/Lead Free solder coating compatible with automatic soldering technologies: reflow, wave soldering, vapor phase and manual.

MAKING AND ORIENTATION IN TAPE

(Top View)

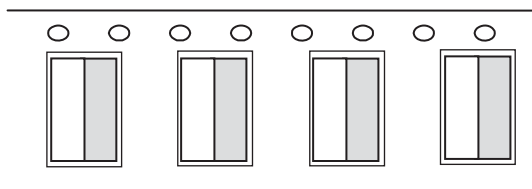

Recommended Pad Layout Dimensions mm (inches)

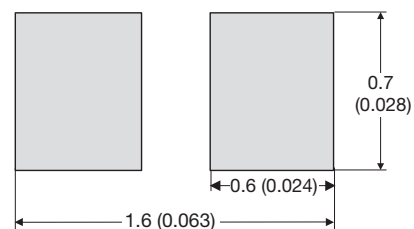

L0402 Tight Tolerance

RF Inductor



ELECTRICAL SPECIFICATIONS

| L(nH) | 450MHz | | | 900MHz | 1900MHz | 2400MHz | SRF min. (MHz) | R _{dc} max. (Ω) | I _{dc} max. (mA) |
|-------|---|---------|---------|---------|---------|---------|----------------|--------------------------|---------------------------|
| | Tolerance A=±0.05nH, B=±0.1nH, C=±0.2nH, D=±0.5nH | Q (min) | Q (Typ) | Q (Typ) | Q (Typ) | Q (Typ) | | | |
| 0.82 | ± 0.05nH, ± 0.1nH | 25 | 40 | 50 | 60 | 70 | 20000 | 0.06 | 500 |
| 1.0 | ± 0.05nH, ± 0.1nH | 20 | 30 | 35 | 40 | 50 | 20000 | 0.15 | 500 |
| 1.2 | ± 0.05nH, ± 0.1nH, ± 0.2nH | 20 | 30 | 30 | 40 | 45 | 20000 | 0.20 | 400 |
| 1.5 | ± 0.05nH, ± 0.1nH, ± 0.2nH | 20 | 25 | 30 | 40 | 40 | 18000 | 0.20 | 400 |
| 1.8 | ± 0.05nH, ± 0.1nH, ± 0.2nH | 18 | 20 | 30 | 35 | 40 | 16000 | 0.20 | 400 |
| 2.2 | ± 0.05nH, ± 0.1nH, ± 0.2nH | 15 | 20 | 25 | 35 | 40 | 15000 | 0.20 | 400 |
| 2.7 | ± 0.05nH, ± 0.1nH, ± 0.2nH | 15 | 20 | 25 | 35 | 40 | 9500 | 0.25 | 250 |
| 3.3 | ± 0.1nH, ± 0.2nH, ± 0.5nH | 15 | 20 | 25 | 35 | 40 | 8500 | 0.40 | 250 |
| 3.9 | ± 0.1nH, ± 0.2nH, ± 0.5nH | 13 | 20 | 20 | 30 | 30 | 8000 | 0.45 | 250 |
| 4.7 | ± 0.1nH, ± 0.2nH, ± 0.5nH | 13 | 20 | 20 | 30 | 30 | 7500 | 0.45 | 250 |
| 5.6 | ± 0.1nH, ± 0.2nH, ± 0.5nH | 13 | 20 | 20 | 30 | 30 | 7000 | 0.65 | 200 |
| 6.8 | ± 0.1nH, ± 0.2nH, ± 0.5nH | 12 | 15 | 20 | 25 | 30 | 6500 | 0.90 | 200 |

Please contact factory for intermediate inductance values within the indicated range.

2

2



10 nH Inductor (Top View)

ACCU-L[®] TECHNOLOGY

The Accu-L[®] SMD Inductor is based on thin-film multilayer technology. This technology provides a level of control on the electrical and physical characteristics of the component which gives consistent characteristics within a lot and lot-to-lot.

The original design provides small size, excellent high-frequency performance and rugged construction for reliable automatic assembly.

The Accu-L[®] inductor is particularly suited for the telecommunications industry where there is a continuing trend towards miniaturization and increasing frequencies. The Accu-L[®] inductor meets both the performance and tolerance requirements of present cellular frequencies 450MHz and 900MHz and of future frequencies, such as 1700MHz, 1900MHz and 2400MHz.

FEATURES

- High Q
- RF Power Capability
- High SRF
- Low DC Resistance
- Ultra-Tight Tolerance on Inductance
- Standard 0603 and 0805 Chip Size
- Low Profile
- Rugged Construction
- Taped and Reeled

APPLICATIONS

- Mobile Communications
- Satellite TV Receivers
- GPS
- Vehicle Locations Systems
- Filters
- Matching Networks

DIMENSIONS: millimeters (inches)

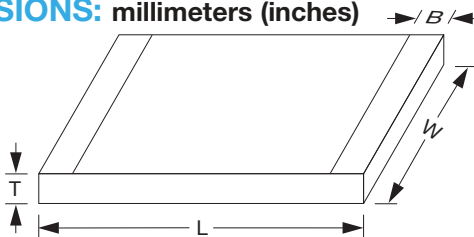

| | 0603 | 0805 |
|----------|---|----------------------------|
| L | 1.6±0.10 (0.063±0.004) | 2.11±0.10 (0.083±0.004) |
| W | 0.81±0.10 (0.032±0.004) | 1.5±0.10 (0.059±0.004) |
| T | 0.61±0.10 (0.024±0.004) | 0.91±0.13 (0.036±0.005) |
| B | top: 0.0 +0.3/-0.0 (0.0+0.012) bottom: 0.35±0.20 (0.014±0.008) | 0.25±0.15 (0.010±0.006) |

Operating/Storage
Temp. Range:
-55°C to +125°C

Accu-L[®] 0603 and 0805

SMD High-Q RF Inductor



HOW TO ORDER

| L | 0805 | 4R7 | D | E | S | TR |
|----------------------------|-----------------------------|---|---|---|---|---|
| Product Inductor | Size 0603 0805 | Inductance Expressed in nH (2 significant digits + number of zeros) for values <10nH, letter R denotes decimal point. Example: 22nH = 220 4.7nH = 4R7 | Tolerance for L ≤ 4.7nH, B = ±0.1nH C = ±0.2nH D = ±0.5nH 4.7nH < L < 10nH, C = ±0.2nH D = ±0.5nH L ≥ 10nH, G = ±2% J = ±5% | Specification Code E = Accu-L [®] 0805 technology G = Accu-L [®] 0603 technology | Termination Code W = Nickel/ solder coated (Sn 63, Pb 37) **S = Nickel/ Lead Free Solder coated (Sn100) | Packaging Code TR = Tape and Reel (3,000/reel) |

Not RoHS Compliant



****RoHS compliant**

**Engineering Kits Available
see pages 90-91**

2

For RoHS compliant products,
please select correct termination style.

ELECTRICAL SPECIFICATIONS TABLE FOR ACCU-L[®] 0603

| 450 MHz Test Frequency | | | 900 MHz Test Frequency | | 1900 MHz Test Frequency | | 2400 MHz Test Frequency | | SRF min (MHz) | R _{DC} max (Ω) | I _{DC} max (mA) |
|------------------------|--------------------------------|-----------|------------------------|-----------|-------------------------|-----------|-------------------------|-----------|---------------|-------------------------|--------------------------|
| Inductance L (nH) | Available Inductance Tolerance | Q Typical | L (nH) | Q Typical | L (nH) | Q Typical | L (nH) | Q Typical | | | |
| 1.2 | ±0.1, ±0.2nH | 49 | 1.2 | 70 | 1.2 | 134 | 1.2 | 170 | 10000 | 0.04 | 1000 |
| 1.5 | ±0.1, ±0.2nH | 26 | 1.54 | 39 | 1.52 | 63 | 1.52 | 76 | 10000 | 0.06 | 1000 |
| 1.8 | ±0.1, ±0.2nH | 20 | 1.74 | 30 | 1.73 | 50 | 1.72 | 59 | 10000 | 0.07 | 1000 |
| 2.2 | ±0.1, ±0.2nH | 20 | 2.2 | 30 | 2.24 | 49 | 2.24 | 56 | 10000 | 0.08 | 1000 |
| 2.7 | ±0.1, ±0.2nH | 21 | 2.7 | 30 | 2.75 | 48 | 2.79 | 54 | 9000 | 0.08 | 750 |
| 3.3 | ±0.1, ±0.2, ±0.5nH | 24 | 3.33 | 35 | 3.39 | 56 | 3.47 | 64 | 8400 | 0.08 | 750 |
| 3.9 | ±0.1, ±0.2, ±0.5nH | 25 | 3.9 | 57 | 4.06 | 60 | 4.21 | 69 | 6500 | 0.12 | 500 |
| 4.7 | ±0.1, ±0.2, ±0.5nH | 23 | 4.68 | 32 | 4.92 | 46 | 5.2 | 49 | 5500 | 0.15 | 500 |
| 5.6 | ±0.2, ±0.5nH | 26 | 5.65 | 36 | 5.94 | 54 | 6.23 | 60 | 5000 | 0.25 | 300 |
| 6.8 | ±0.2, ±0.5nH | 23 | 6.9 | 33 | 7.3 | 47 | 8.1 | 39 | 4500 | 0.30 | 300 |
| 8.2 | ±0.2, ±0.5nH | 23 | 8.4 | 31 | 10 | 35 | 12.1 | 31 | 3800 | 0.35 | 300 |
| 10.0 | ±2%, ±5% | 28 | 10 | 39 | 11.8 | 47 | 14.1 | 41 | 3500 | 0.45 | 300 |
| 12.0 | ±2%, ±5% | 28 | 13.2 | 38 | 14.1 | 30 | 17.2 | 20 | 3000 | 0.50 | 300 |
| 15.0 | ±2%, ±5% | 28 | 16.2 | 38 | 25.9 | 30 | 49.8 | 15 | 2500 | 0.60 | 300 |

(1) I_{DC} measured for 15°C rise at 25°C ambient temperature when soldered to FR-4 board. Inductance and Q measured on Agilent 4291B / 4287 using the 16196A test fixture.

ELECTRICAL SPECIFICATIONS TABLE FOR ACCU-L[®] 0805

| 450 MHz Test Frequency | | | 900 MHz Test Frequency | | 1700 MHz Test Frequency | | 2400 MHz Test Frequency | | SRF min (MHz) | R _{DC} max (Ω) | I _{DC} max (mA) | |
|------------------------|--------------------------------|-----------|------------------------|-----------|-------------------------|-----------|-------------------------|-----------|---------------|-------------------------|--------------------------|---------------|
| Inductance L (nH) | Available Inductance Tolerance | Q Typical | L (nH) | Q Typical | L (nH) | Q Typical | L (nH) | Q Typical | | | ΔT = 15°C (1) | ΔT = 70°C (2) |
| 1.2 | ±0.1nH, ±0.2nH, ±0.5nH | 60 | 1.2 | 92 | 1.2 | 122 | 1.2 | 92 | 10000 | 0.05 | 1000 | 2000 |
| 1.5 | ±0.1nH, ±0.2nH, ±0.5nH | 50 | 1.5 | 74 | 1.5 | 102 | 1.5 | 84 | 10000 | 0.05 | 1000 | 2000 |
| 1.8 | ±0.1nH, ±0.2nH, ±0.5nH | 50 | 1.8 | 72 | 1.8 | 88 | 1.9 | 73 | 10000 | 0.06 | 1000 | 2000 |
| 2.2 | ±0.1nH, ±0.2nH, ±0.5nH | 42 | 2.2 | 62 | 2.2 | 82 | 2.3 | 72 | 10000 | 0.07 | 1000 | 2000 |
| 2.7 | ±0.1nH, ±0.2nH, ±0.5nH | 42 | 2.7 | 62 | 2.8 | 80 | 2.9 | 70 | 10000 | 0.08 | 1000 | 2000 |
| 3.3 | ±0.1nH, ±0.2nH, ±0.5nH | 38 | 3.3 | 46 | 3.4 | 48 | 3.5 | 57 | 10000 | 0.11 | 750 | 1500 |
| 3.9 | ±0.1nH, ±0.2nH, ±0.5nH | 27 | 3.9 | 36 | 4.0 | 38 | 4.1 | 42 | 10000 | 0.20 | 750 | 1500 |
| 4.7 | ±0.1nH, ±0.2nH, ±0.5nH | 43 | 4.8 | 62 | 5.3 | 76 | 5.8 | 60 | 5500 | 0.10 | 750 | 1500 |
| 5.6 | ±0.5nH | 50 | 5.7 | 68 | 6.3 | 73 | 7.6 | 62 | 4600 | 0.10 | 750 | 1500 |
| 6.8 | ±0.5nH | 43 | 7.0 | 62 | 7.7 | 71 | 9.4 | 50 | 4500 | 0.11 | 750 | 1500 |
| 8.2 | ±0.5nH | 43 | 8.5 | 56 | 10.0 | 55 | 15.2 | 32 | 3500 | 0.12 | 750 | 1500 |
| 10 | ±2%, ±5% | 46 | 10.6 | 60 | 13.4 | 52 | - | - | 2500 | 0.13 | 750 | 1500 |
| 12 | ±2%, ±5% | 40 | 12.9 | 50 | 17.3 | 40 | - | - | 2400 | 0.20 | 750 | 1500 |
| 15 | ±2%, ±5% | 36 | 16.7 | 46 | 27 | 23 | - | - | 2200 | 0.20 | 750 | 1000 |
| 18 | ±2%, ±5% | 30 | 21.9 | 27 | - | - | - | - | 1700 | 0.35 | 500 | 1000 |
| 22 | ±2%, ±5% | 36 | 27.5 | 33 | - | - | - | - | 1400 | 0.40 | 500 | 1000 |

(1) I_{DC} measured for 15°C rise at 25°C ambient temperature
 (2) I_{DC} measured for 70°C rise at 25°C ambient temperature
 L, Q, SRF measured on HP 4291A, Boonton 34A and Wiltron 360 Vector Analyzer, R_{DC} measured on Keithley 580 micro-ohmmeter.



Accu-L[®] 0603 and 0805



SMD High-Q RF Inductor

L0603

Typical Q vs. Frequency
L0603

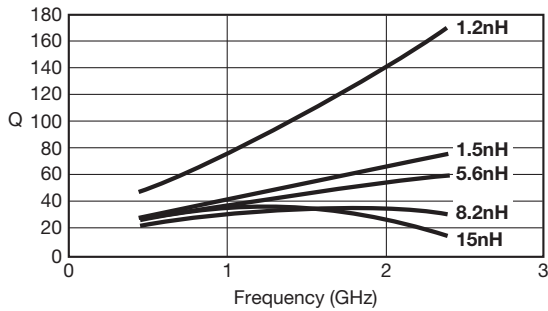

Measured on AGILENT 4291B/4287
using the 16196A test fixture

Typical Inductance vs. Frequency
L0603

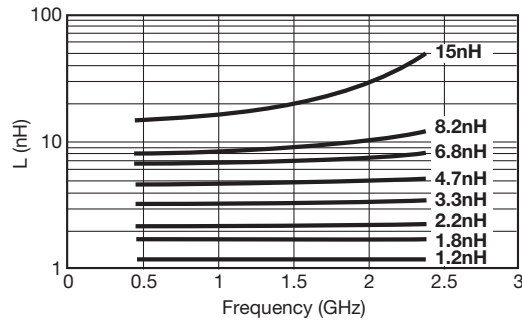

Measured on AGILENT 4291B/4287
using the 16196A test fixture

L0805

Typical Q vs. Frequency
L0805

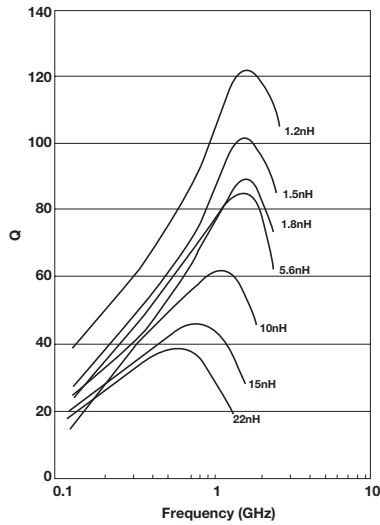

Measured on HP4291A and
Boonton 34A Coaxial Line

Typical Inductance vs. Frequency
L0805

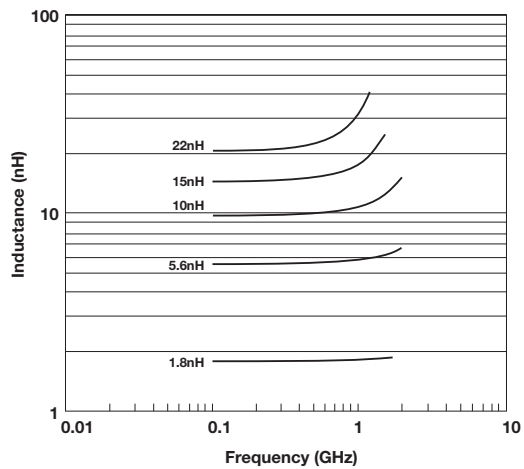

Measured on HP4291A and
Wiltron 360 Vector Analyzer

Maximum Temperature Rise
at 25°C ambient temperature (on FR-4)
L0805

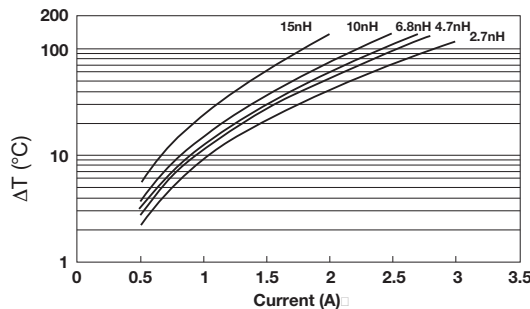

Temperature rise will typically be no higher than shown by the graph

Accu-L[®] 0603 and 0805



SMD High-Q RF Inductor

FINAL QUALITY INSPECTION

Finished parts are tested for electrical parameters and visual/mechanical characteristics.

Parts are 100% tested for inductance at 450MHz. Parts are 100% tested for R_{DC}. Each production lot is evaluated on a sample basis for:

- Q at test frequency
- Static Humidity Resistance: 85°C, 85% RH, 160 hours
- Endurance: 125°C, I_R, 4 hours

2

ENVIRONMENTAL CHARACTERISTICS

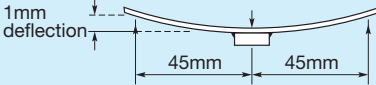
| TEST | CONDITIONS | REQUIREMENT |
|--|---|--|
| Solderability | Components completely immersed in a solder bath at 235 ± 5°C for 2 secs. | Terminations to be well tinned. No visible damage. |
| Leach Resistance | Components completely immersed in a solder bath at 260 ± 5°C for 60 secs. | Dissolution of termination faces ≤ 15% of area. Dissolution of termination edges ≤ 25% of length. |
| Storage | 12 months minimum with components stored in "as received" packaging. | Good solderability |
| Shear | Components mounted to a substrate. A force of 5N applied normal to the line joining the terminations and in a line parallel to the substrate. | No visible damage |
| Rapid Change of Temperature | Components mounted to a substrate. 5 cycles -55°C to +125°C. | No visible damage |
| Bend Strength | Tested as shown in diagram  | No visible damage |
| Temperature Coefficient of Inductance (TCL) | Component placed in environmental chamber -55°C to +125°C. | +0 to +125 ppm/°C (typical) $TCL = \frac{L_2 - L_1}{L_1 (T_2 - T_1)} \cdot 10^6$ $T_1 = 25^\circ C$ |

Application Notes

HANDLING

SMD chips should be handled with care to avoid damage or contamination from perspiration and skin oils. The use of plastic tipped tweezers or vacuum pick-ups is strongly recommended for individual components. Bulk handling should ensure that abrasion and mechanical shock are minimized. For automatic equipment, taped and reeled product is the ideal medium for direct presentation to the placement machine.

CIRCUIT BOARD TYPE

All flexible types of circuit boards may be used (e.g. FR-4, G-10) and also alumina.

For other circuit board materials, please consult factory.

COMPONENT PAD DESIGN

Component pads must be designed to achieve good joints and minimize component movement during soldering.

Pad designs are given below for both wave and reflow soldering.

The basis of these designs is:

- Pad width equal to component width. It is permissible to decrease this to as low as 85% of component width but it is not advisable to go below this.
- Pad overlap about 0.3mm.
- Pad extension about 0.3mm for reflow.
Pad extension about 0.8mm for wave soldering.

WAVE SOLDERING

DIMENSIONS: millimeters (inches)

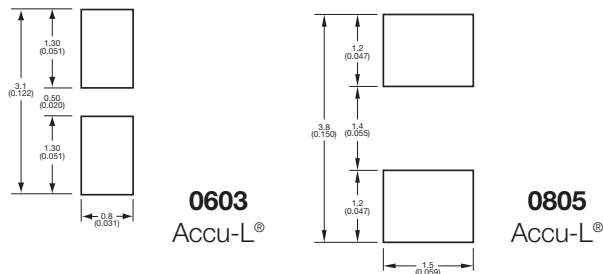

REFLOW SOLDERING

DIMENSIONS: millimeters (inches)

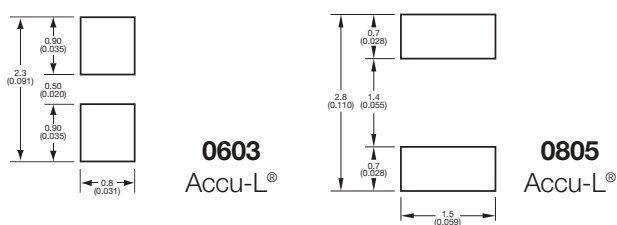

PREHEAT & SOLDERING

The rate of preheat in production should not exceed 4°C/second. It is recommended not to exceed 2°C/second.

Temperature differential from preheat to soldering should not exceed 150°C.

For further specific application or process advice, please consult AVX.

HAND SOLDERING & REWORK

Hand soldering is permissible. Preheat of the PCB to 100°C is required. The most preferable technique is to use hot air soldering tools. Where a soldering iron is used, a temperature controlled model not exceeding 30 watts should be used and set to not more than 260°C. Maximum allowed time at temperature is 1 minute. When hand soldering, the base side (white side) must be soldered to the board.

COOLING

After soldering, the assembly should preferably be allowed to cool naturally. In the event of assisted cooling, similar conditions to those recommended for preheating should be used.

CLEANING RECOMMENDATIONS

Care should be taken to ensure that the devices are thoroughly cleaned of flux residues, especially the space beneath the device. Such residues may otherwise become conductive and effectively offer a lossy bypass to the device. Various recommended cleaning conditions (which must be optimized for the flux system being used) are as follows:

Cleaning liquids i-propanol, ethanol, acetylacetone, water, and other standard PCB cleaning liquids.

Ultrasonic conditions . . . power – 20w/liter max.
frequency – 20kHz to 45kHz.

Temperature 80°C maximum (if not otherwise limited by chosen solvent system).

Time 5 minutes max.

STORAGE CONDITIONS

Recommended storage conditions for Accu-L[®] prior to use are as follows:

Temperature 15°C to 35°C

Humidity ≤65%

Air Pressure 860mbar to 1060mbar

RECOMMENDED SOLDERING PROFILE

For recommended soldering profile see page 23

AVX RF

**Thin-Film RF/Microwave
Inductor Technology**

Accu-L[®]

Accu-L[®] 0201 Tight Tolerance



SMD RF Thin Film Tuning Inductor

2



ACCU-L[®] TECHNOLOGY

The L0201 SMD Tuning Inductor is based on thin-film multilayer technology. The technology provides a miniature part with excellent high frequency performance and rugged construction for reliable automatic assembly.

APPLICATIONS

- Mobile Communications
- Satellite TV Receivers
- GPS
- Vehicle Location Systems
- Wireless LAN's
- Filters
- Matching Networks

HOW TO ORDER

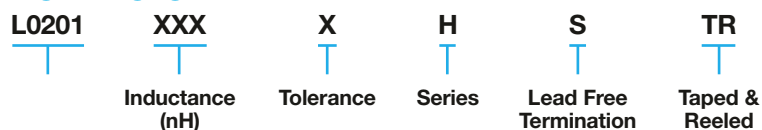

P/N Example: **L02013R3BHSTR**

QUALITY INSPECTION

Finished parts are 100% tested for electrical parameters and visual characteristics. Each production lot is evaluated on a sample basis for:

- Static Humidity: 85°C, 85% RH, 160 hours
- Endurance: 125°C, I_r , 4 hours

TERMINATION

Nickel/Lead Free solder coating compatible with automatic soldering technologies: reflow, wave soldering, vapor phase and manual.

DIMENSIONS: (TOP View)

millimeters (inches)

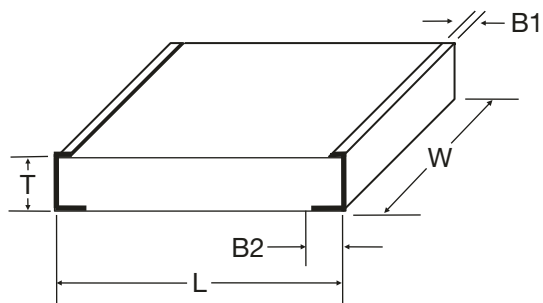

| | |
|----------|------------------------------|
| L | 0.600±0.050 (0.024±0.002) |
| W | 0.325±0.050 (0.013±0.002) |
| T | 0.225±0.050 (0.009±0.002) |

| | |
|-----------|------------------------------|
| B1 | 0.100±0.100 (0.004±0.004) |
| B2 | 0.150±0.050 (0.006±0.002) |

Recommended Pad Layout Dimensions

mm (inches)

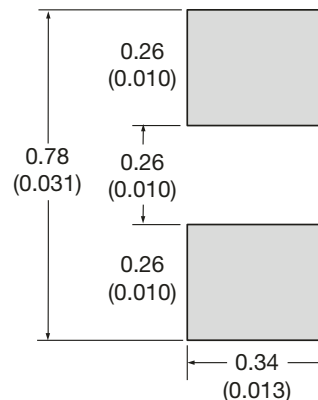

Accu-L[®] 0201 Tight Tolerance

SMD RF Thin Film Tuning Inductor



ELECTRICAL SPECIFICATIONS

| L(nH) | 450MHz | | 900MHz | 1900MHz | 2400MHz | SRF min. (MHz) | R _{dc} max. (Ω) | I _{dc} max. (mA) |
|-------|---|---------|---------|---------|---------|----------------|--------------------------|---------------------------|
| | Tolerance A=±0.05nH, B=±0.1nH, C=±0.2nH, D=±0.5nH | Q (min) | Q (Typ) | Q (Typ) | Q (Typ) | | | |
| 0.33 | ±0.05nH, ± 0.1nH, ± 0.2nH | 13 | 24 | 36 | 39 | 35 | 0.1 | 550 |
| 0.39 | ±0.05nH, ± 0.1nH, ± 0.2nH | 11 | 23 | 34 | 38 | 33 | 0.1 | 550 |
| 0.47 | ±0.05nH, ± 0.1nH, ± 0.2nH | 10 | 18 | 26 | 30 | 32 | 0.1 | 550 |
| 0.56 | ±0.05nH, ± 0.1nH, ± 0.2nH | 9 | 16 | 24 | 27 | 31 | 0.1 | 500 |
| 0.68 | ±0.05nH, ± 0.1nH, ± 0.2nH | 8 | 19 | 28 | 32 | 30 | 0.2 | 500 |
| 0.82 | ±0.05nH, ± 0.1nH, ± 0.2nH | 8 | 19 | 28 | 32 | 28 | 0.2 | 400 |
| 1.0 | ±0.05nH, ± 0.1nH, ± 0.2nH | 7 | 16 | 26 | 30 | 26 | 0.2 | 400 |
| 1.2 | ±0.05nH, ± 0.1nH, ± 0.2nH | 7 | 16 | 26 | 30 | 24 | 0.3 | 300 |
| 1.5 | ± 0.1nH, ± 0.2nH, ± 0.5nH | 7 | 16 | 26 | 30 | 23 | 0.5 | 250 |
| 1.8 | ± 0.1nH, ± 0.2nH, ± 0.5nH | 7 | 15 | 25 | 29 | 20 | 0.5 | 250 |
| 2.2 | ± 0.1nH, ± 0.2nH, ± 0.5nH | 7 | 15 | 22 | 24 | 18 | 0.6 | 200 |
| 2.7 | ± 0.1nH, ± 0.2nH, ± 0.5nH | 7 | 15 | 22 | 24 | 14 | 0.7 | 180 |
| 3.3 | ± 0.1nH, ± 0.2nH, ± 0.5nH | 7 | 15 | 22 | 24 | 13 | 1.0 | 150 |

All intermediate Inductance values within the indicated range are available.



L0402 Tight Tolerance



RF Inductor

GENERAL DESCRIPTION ITF TECHNOLOGY

The L0402 LGA Inductor is based on thin-film multilayer technology. The technology provides a miniature part with excellent high frequency performance and rugged construction for reliable automatic assembly.

APPLICATIONS

- Mobile Communications
- Satellite TV Receivers
- GPS
- Vehicle Location Systems
- Wireless LAN's
- Filters
- Matching Networks

LAND GRID ARRAY ADVANTAGES

- Inherent Low Profile
- Self Alignment during Reflow
- Excellent Solderability
- Low Parasitics
- Better Heat Dissipation

DIMENSIONS: (Bottom View)

millimeters (inches)

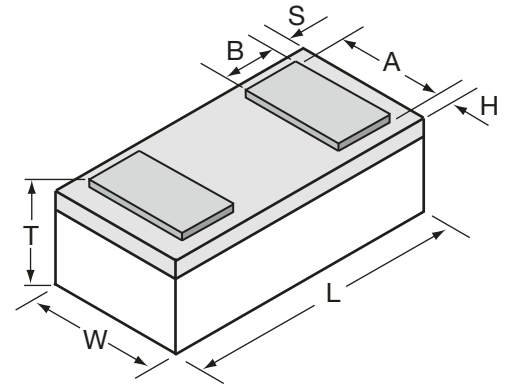

| | |
|---|----------------------------|
| L | 1.00±0.10 (0.039±0.004) |
| W | 0.58±0.07 (0.023±0.003) |
| T | 0.35±0.10 (0.014±0.004) |

| | |
|------|-----------------------------|
| A | 0.48±0.05 (0.019±0.002) |
| B | 0.17±0.05 (0.007±0.002) |
| S, H | 0.064±0.05 (0.003±0.002) |

HOW TO ORDER



P/N Example: **L04023R3BHNTTR**



QUALITY INSPECTION

Finished parts are 100% tested for electrical parameters and visual characteristics. Each production lot is evaluated on a sample basis for:

- Static Humidity: 85°C, 85% RH, 160 hours
- Endurance: 125°C, I_R, 4 hours

TERMINATION

Nickel/Lead Free solder coating compatible with automatic soldering technologies: reflow, wave soldering, vapor phase and manual.

MAKING AND ORIENTATION IN TAPE

(Top View)

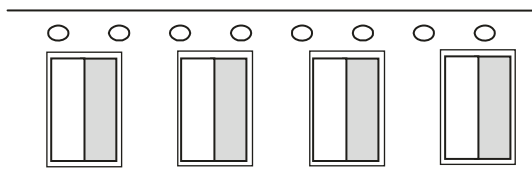

Recommended Pad Layout Dimensions mm (inches)

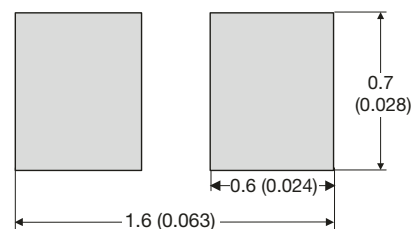

L0402 Tight Tolerance

RF Inductor



ELECTRICAL SPECIFICATIONS

| L(nH) | 450MHz | | 900MHz | 1900MHz | 2400MHz | SRF min. (MHz) | R _{dc} max. (Ω) | I _{dc} max. (mA) | |
|-------|---|---------|---------|---------|---------|----------------|--------------------------|---------------------------|------|
| | Tolerance A=±0.05nH, B=±0.1nH, C=±0.2nH, D=±0.5nH | Q (min) | Q (Typ) | Q (Typ) | Q (Typ) | | | | |
| 0.56 | ± 0.05nH, ± 0.1nH | 35 | 45 | 55 | 65 | 75 | 20000 | 0.02 | 1000 |
| 0.68 | ± 0.05nH, ± 0.1nH | 30 | 40 | 50 | 60 | 70 | 20000 | 0.04 | 750 |
| 0.82 | ± 0.05nH, ± 0.1nH | 25 | 40 | 50 | 60 | 70 | 20000 | 0.06 | 500 |
| 1.0 | ± 0.05nH, ± 0.1nH | 20 | 30 | 35 | 40 | 50 | 20000 | 0.15 | 500 |
| 1.2 | ± 0.05nH, ± 0.1nH, ± 0.2nH | 20 | 30 | 30 | 40 | 45 | 20000 | 0.20 | 400 |
| 1.5 | ± 0.05nH, ± 0.1nH, ± 0.2nH | 20 | 25 | 30 | 40 | 40 | 18000 | 0.20 | 400 |
| 1.8 | ± 0.05nH, ± 0.1nH, ± 0.2nH | 18 | 20 | 30 | 35 | 40 | 16000 | 0.20 | 400 |
| 2.2 | ± 0.05nH, ± 0.1nH, ± 0.2nH | 15 | 20 | 25 | 35 | 40 | 15000 | 0.20 | 400 |
| 2.7 | ± 0.05nH, ± 0.1nH, ± 0.2nH | 15 | 20 | 25 | 35 | 40 | 9500 | 0.25 | 250 |
| 3.3 | ± 0.1nH, ± 0.2nH, ± 0.5nH | 15 | 20 | 25 | 35 | 40 | 8500 | 0.40 | 250 |
| 3.9 | ± 0.1nH, ± 0.2nH, ± 0.5nH | 13 | 20 | 20 | 30 | 30 | 8000 | 0.45 | 250 |
| 4.7 | ± 0.1nH, ± 0.2nH, ± 0.5nH | 13 | 20 | 20 | 30 | 30 | 7500 | 0.45 | 250 |
| 5.6 | ± 0.1nH, ± 0.2nH, ± 0.5nH | 13 | 20 | 20 | 30 | 30 | 7000 | 0.65 | 200 |
| 6.8 | ± 0.1nH, ± 0.2nH, ± 0.5nH | 12 | 15 | 20 | 25 | 30 | 6500 | 0.90 | 200 |

Please contact factory for intermediate inductance values within the indicated range.





10 nH Inductor (Top View)

ACCU-L[®] TECHNOLOGY

The Accu-L[®] SMD Inductor is based on thin-film multilayer technology. This technology provides a level of control on the electrical and physical characteristics of the component which gives consistent characteristics within a lot and lot-to-lot.

The original design provides small size, excellent high-frequency performance and rugged construction for reliable automatic assembly.

The Accu-L[®] inductor is particularly suited for the telecommunications industry where there is a continuing trend towards miniaturization and increasing frequencies. The Accu-L[®] inductor meets both the performance and tolerance requirements of present cellular frequencies 450MHz and 900MHz and of future frequencies, such as 1700MHz, 1900MHz and 2400MHz.

FEATURES

- High Q
- RF Power Capability
- High SRF
- Low DC Resistance
- Ultra-Tight Tolerance on Inductance
- Standard 0603 and 0805 Chip Size
- Low Profile
- Rugged Construction
- Taped and Reeled

APPLICATIONS

- Mobile Communications
- Satellite TV Receivers
- GPS
- Vehicle Locations Systems
- Filters
- Matching Networks

DIMENSIONS: millimeters (inches)

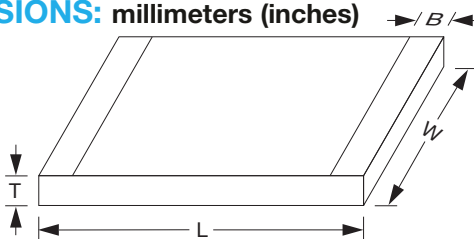

| | 0603 | 0805 |
|----------|---|----------------------------|
| L | 1.6±0.10 (0.063±0.004) | 2.11±0.10 (0.083±0.004) |
| W | 0.81±0.10 (0.032±0.004) | 1.5±0.10 (0.059±0.004) |
| T | 0.61±0.10 (0.024±0.004) | 0.91±0.13 (0.036±0.005) |
| B | top: 0.0 +0.3/-0.0 (0.0+0.012) bottom: 0.35±0.20 (0.014±0.008) | 0.25±0.15 (0.010±0.006) |

Operating/Storage
Temp. Range:
-55°C to +125°C

Accu-L[®] 0603 and 0805

SMD High-Q RF Inductor



HOW TO ORDER

| L | 0805 | 4R7 | D | E | S | TR |
|----------------------------|-----------------------------|---|---|---|---|---|
| Product Inductor | Size 0603 0805 | Inductance Expressed in nH (2 significant digits + number of zeros) for values <10nH, letter R denotes decimal point. Example: 22nH = 220 4.7nH = 4R7 | Tolerance for L ≤ 4.7nH, B = ±0.1nH C = ±0.2nH D = ±0.5nH 4.7nH < L < 10nH, C = ±0.2nH D = ±0.5nH L ≥ 10nH, G = ±2% J = ±5% | Specification Code E = Accu-L [®] 0805 technology G = Accu-L [®] 0603 technology | Termination Code W = Nickel/ solder coated (Sn 63, Pb 37) **S = Nickel/ Lead Free Solder coated (Sn100) | Packaging Code TR = Tape and Reel (3,000/reel) |

Not RoHS Compliant



****RoHS compliant**

**Engineering Kits Available
see pages 114-115**

2

For RoHS compliant products,
please select correct termination style.

ELECTRICAL SPECIFICATIONS TABLE FOR ACCU-L[®] 0603

| 450 MHz Test Frequency | | | 900 MHz Test Frequency | | 1900 MHz Test Frequency | | 2400 MHz Test Frequency | | SRF min (MHz) | R _{DC} max (Ω) | I _{DC} max (mA) |
|------------------------|--------------------------------|-----------|------------------------|-----------|-------------------------|-----------|-------------------------|-----------|---------------|-------------------------|--------------------------|
| Inductance L (nH) | Available Inductance Tolerance | Q Typical | L (nH) | Q Typical | L (nH) | Q Typical | L (nH) | Q Typical | | | |
| 1.2 | ±0.1, ±0.2nH | 49 | 1.2 | 70 | 1.2 | 134 | 1.2 | 170 | 10000 | 0.04 | 1000 |
| 1.5 | ±0.1, ±0.2nH | 26 | 1.54 | 39 | 1.52 | 63 | 1.52 | 76 | 10000 | 0.06 | 1000 |
| 1.8 | ±0.1, ±0.2nH | 20 | 1.74 | 30 | 1.73 | 50 | 1.72 | 59 | 10000 | 0.07 | 1000 |
| 2.2 | ±0.1, ±0.2nH | 20 | 2.2 | 30 | 2.24 | 49 | 2.24 | 56 | 10000 | 0.08 | 1000 |
| 2.7 | ±0.1, ±0.2nH | 21 | 2.7 | 30 | 2.75 | 48 | 2.79 | 54 | 9000 | 0.08 | 750 |
| 3.3 | ±0.1, ±0.2, ±0.5nH | 24 | 3.33 | 35 | 3.39 | 56 | 3.47 | 64 | 8400 | 0.08 | 750 |
| 3.9 | ±0.1, ±0.2, ±0.5nH | 25 | 3.9 | 57 | 4.06 | 60 | 4.21 | 69 | 6500 | 0.12 | 500 |
| 4.7 | ±0.1, ±0.2, ±0.5nH | 23 | 4.68 | 32 | 4.92 | 46 | 5.2 | 49 | 5500 | 0.15 | 500 |
| 5.6 | ±0.2, ±0.5nH | 26 | 5.65 | 36 | 5.94 | 54 | 6.23 | 60 | 5000 | 0.25 | 300 |
| 6.8 | ±0.2, ±0.5nH | 23 | 6.9 | 33 | 7.3 | 47 | 8.1 | 39 | 4500 | 0.30 | 300 |
| 8.2 | ±0.2, ±0.5nH | 23 | 8.4 | 31 | 10 | 35 | 12.1 | 31 | 3800 | 0.35 | 300 |
| 10.0 | ±2%, ±5% | 28 | 10 | 39 | 11.8 | 47 | 14.1 | 41 | 3500 | 0.45 | 300 |
| 12.0 | ±2%, ±5% | 28 | 13.2 | 38 | 14.1 | 30 | 17.2 | 20 | 3000 | 0.50 | 300 |
| 15.0 | ±2%, ±5% | 28 | 16.2 | 38 | 25.9 | 30 | 49.8 | 15 | 2500 | 0.60 | 300 |

(1) I_{DC} measured for 15°C rise at 25°C ambient temperature when soldered to FR-4 board. Inductance and Q measured on Agilent 4291B / 4287 using the 16196A test fixture.

ELECTRICAL SPECIFICATIONS TABLE FOR ACCU-L[®] 0805

| 450 MHz Test Frequency | | | 900 MHz Test Frequency | | 1700 MHz Test Frequency | | 2400 MHz Test Frequency | | SRF min (MHz) | R _{DC} max (Ω) | I _{DC} max (mA) | |
|------------------------|--------------------------------|-----------|------------------------|-----------|-------------------------|-----------|-------------------------|-----------|---------------|-------------------------|--------------------------|---------------|
| Inductance L (nH) | Available Inductance Tolerance | Q Typical | L (nH) | Q Typical | L (nH) | Q Typical | L (nH) | Q Typical | | | ΔT = 15°C (1) | ΔT = 70°C (2) |
| 1.2 | ±0.1nH, ±0.2nH, ±0.5nH | 60 | 1.2 | 92 | 1.2 | 122 | 1.2 | 92 | 10000 | 0.05 | 1000 | 2000 |
| 1.5 | ±0.1nH, ±0.2nH, ±0.5nH | 50 | 1.5 | 74 | 1.5 | 102 | 1.5 | 84 | 10000 | 0.05 | 1000 | 2000 |
| 1.8 | ±0.1nH, ±0.2nH, ±0.5nH | 50 | 1.8 | 72 | 1.8 | 88 | 1.9 | 73 | 10000 | 0.06 | 1000 | 2000 |
| 2.2 | ±0.1nH, ±0.2nH, ±0.5nH | 42 | 2.2 | 62 | 2.2 | 82 | 2.3 | 72 | 10000 | 0.07 | 1000 | 2000 |
| 2.7 | ±0.1nH, ±0.2nH, ±0.5nH | 42 | 2.7 | 62 | 2.8 | 80 | 2.9 | 70 | 10000 | 0.08 | 1000 | 2000 |
| 3.3 | ±0.1nH, ±0.2nH, ±0.5nH | 38 | 3.3 | 46 | 3.4 | 48 | 3.5 | 57 | 10000 | 0.11 | 750 | 1500 |
| 3.9 | ±0.1nH, ±0.2nH, ±0.5nH | 27 | 3.9 | 36 | 4.0 | 38 | 4.1 | 42 | 10000 | 0.20 | 750 | 1500 |
| 4.7 | ±0.1nH, ±0.2nH, ±0.5nH | 43 | 4.8 | 62 | 5.3 | 76 | 5.8 | 60 | 5500 | 0.10 | 750 | 1500 |
| 5.6 | ±0.5nH | 50 | 5.7 | 68 | 6.3 | 73 | 7.6 | 62 | 4600 | 0.10 | 750 | 1500 |
| 6.8 | ±0.5nH | 43 | 7.0 | 62 | 7.7 | 71 | 9.4 | 50 | 4500 | 0.11 | 750 | 1500 |
| 8.2 | ±0.5nH | 43 | 8.5 | 56 | 10.0 | 55 | 15.2 | 32 | 3500 | 0.12 | 750 | 1500 |
| 10 | ±2%, ±5% | 46 | 10.6 | 60 | 13.4 | 52 | - | - | 2500 | 0.13 | 750 | 1500 |
| 12 | ±2%, ±5% | 40 | 12.9 | 50 | 17.3 | 40 | - | - | 2400 | 0.20 | 750 | 1500 |
| 15 | ±2%, ±5% | 36 | 16.7 | 46 | 27 | 23 | - | - | 2200 | 0.20 | 750 | 1000 |
| 18 | ±2%, ±5% | 30 | 21.9 | 27 | - | - | - | - | 1700 | 0.35 | 500 | 1000 |
| 22 | ±2%, ±5% | 36 | 27.5 | 33 | - | - | - | - | 1400 | 0.40 | 500 | 1000 |

(1) I_{DC} measured for 15°C rise at 25°C ambient temperature
 (2) I_{DC} measured for 70°C rise at 25°C ambient temperature
 L, Q, SRF measured on HP 4291A, Boonton 34A and Wiltron 360 Vector Analyzer, R_{DC} measured on Keithley 580 micro-ohmmeter.



Accu-L[®] 0603 and 0805



SMD High-Q RF Inductor

L0603

Typical Q vs. Frequency
L0603

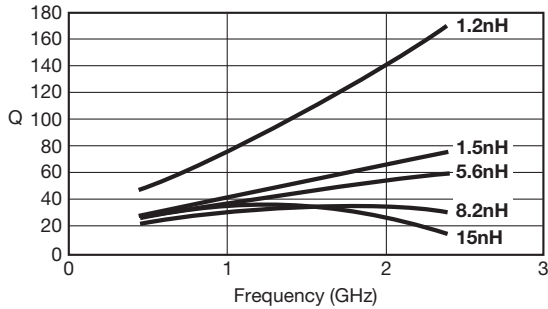

Measured on AGILENT 4291B/4287
using the 16196A test fixture

Typical Inductance vs. Frequency
L0603

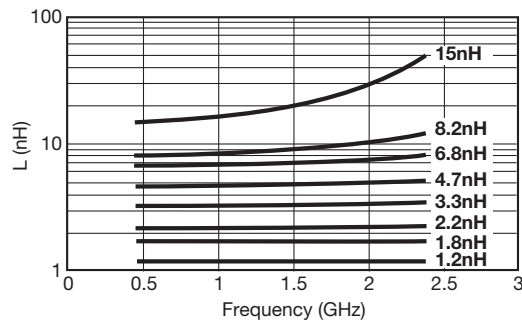

Measured on AGILENT 4291B/4287
using the 16196A test fixture

L0805

Typical Q vs. Frequency
L0805

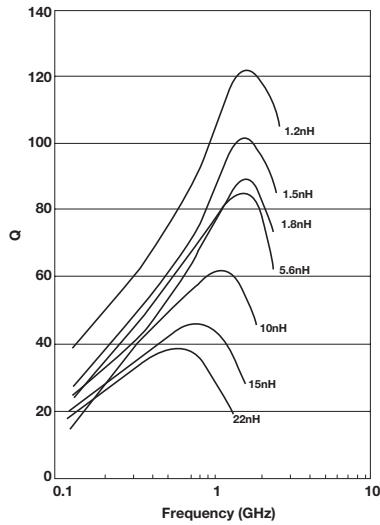

Measured on HP4291A and
Boonton 34A Coaxial Line

Typical Inductance vs. Frequency
L0805

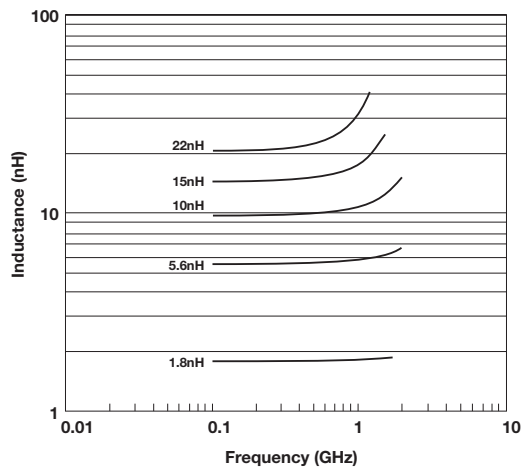

Measured on HP4291A and
Wiltron 360 Vector Analyzer

Maximum Temperature Rise
at 25°C ambient temperature (on FR-4)
L0805

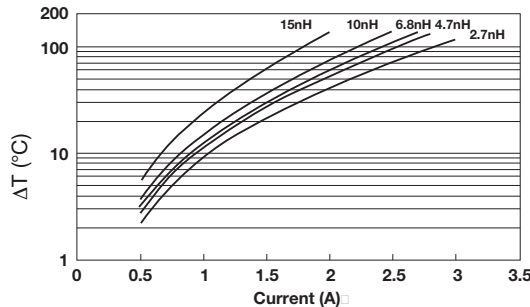

Temperature rise will typically be no higher than shown by the graph



Accu-L[®] 0603 and 0805



SMD High-Q RF Inductor

FINAL QUALITY INSPECTION

Finished parts are tested for electrical parameters and visual/mechanical characteristics.

Parts are 100% tested for inductance at 450MHz. Parts are 100% tested for R_{DC}. Each production lot is evaluated on a sample basis for:

- Q at test frequency
- Static Humidity Resistance: 85°C, 85% RH, 160 hours
- Endurance: 125°C, I_R, 4 hours

2

ENVIRONMENTAL CHARACTERISTICS

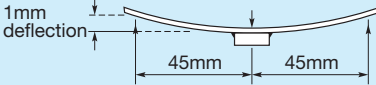
| TEST | CONDITIONS | REQUIREMENT |
|--|---|--|
| Solderability | Components completely immersed in a solder bath at 235 ± 5°C for 2 secs. | Terminations to be well tinned. No visible damage. |
| Leach Resistance | Components completely immersed in a solder bath at 260 ± 5°C for 60 secs. | Dissolution of termination faces ≤ 15% of area. Dissolution of termination edges ≤ 25% of length. |
| Storage | 12 months minimum with components stored in "as received" packaging. | Good solderability |
| Shear | Components mounted to a substrate. A force of 5N applied normal to the line joining the terminations and in a line parallel to the substrate. | No visible damage |
| Rapid Change of Temperature | Components mounted to a substrate. 5 cycles -55°C to +125°C. | No visible damage |
| Bend Strength | Tested as shown in diagram  | No visible damage |
| Temperature Coefficient of Inductance (TCL) | Component placed in environmental chamber -55°C to +125°C. | +0 to +125 ppm/°C (typical) $TCL = \frac{L_2 - L_1}{L_1 (T_2 - T_1)} \cdot 10^6$ $T_1 = 25^\circ C$ |

Application Notes

HANDLING

SMD chips should be handled with care to avoid damage or contamination from perspiration and skin oils. The use of plastic tipped tweezers or vacuum pick-ups is strongly recommended for individual components. Bulk handling should ensure that abrasion and mechanical shock are minimized. For automatic equipment, taped and reeled product is the ideal medium for direct presentation to the placement machine.

CIRCUIT BOARD TYPE

All flexible types of circuit boards may be used (e.g. FR-4, G-10) and also alumina.

For other circuit board materials, please consult factory.

COMPONENT PAD DESIGN

Component pads must be designed to achieve good joints and minimize component movement during soldering.

Pad designs are given below for both wave and reflow soldering.

The basis of these designs is:

- Pad width equal to component width. It is permissible to decrease this to as low as 85% of component width but it is not advisable to go below this.
- Pad overlap about 0.3mm.
- Pad extension about 0.3mm for reflow.
Pad extension about 0.8mm for wave soldering.

REFLOW SOLDERING

DIMENSIONS: millimeters (inches)

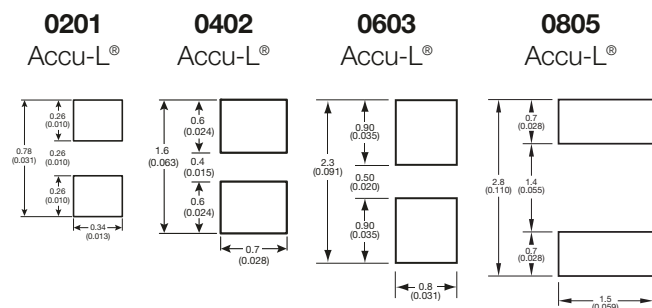

PREHEAT & SOLDERING

The rate of preheat in production should not exceed 4°C/second. It is recommended not to exceed 2°C/second.

Temperature differential from preheat to soldering should not exceed 150°C.

For further specific application or process advice, please consult AVX.

HAND SOLDERING & REWORK

Hand soldering is permissible. Preheat of the PCB to 100°C is required. The most preferable technique is to use hot air soldering tools. Where a soldering iron is used, a temperature controlled model not exceeding 30 watts should be used and set to not more than 260°C. Maximum allowed time at temperature is 1 minute. When hand soldering, the base side (white side) must be soldered to the board.

COOLING

After soldering, the assembly should preferably be allowed to cool naturally. In the event of assisted cooling, similar conditions to those recommended for preheating should be used.

CLEANING RECOMMENDATIONS

Care should be taken to ensure that the devices are thoroughly cleaned of flux residues, especially the space beneath the device. Such residues may otherwise become conductive and effectively offer a lossy bypass to the device. Various recommended cleaning conditions (which must be optimized for the flux system being used) are as follows:

- Cleaning liquids i-propanol, ethanol, acetone, water, and other standard PCB cleaning liquids.
- Ultrasonic conditions . . . power – 20w/liter max.
frequency – 20kHz to 45kHz.
- Temperature 80°C maximum (if not otherwise limited by chosen solvent system).
- Time. 5 minutes max.

STORAGE CONDITIONS

Recommended storage conditions for Accu-L[®] prior to use are as follows:

- Temperature. 15°C to 35°C
- Humidity ≤65%
- Air Pressure 860mbar to 1060mbar

RECOMMENDED SOLDERING PROFILE

For recommended soldering profile see page 29