



TYPE 3R Rainproof

PowerGATE™ 400 Amp Power Input Panel Transfer Switch Accessory

LEX
We Deliver the Power™

A safe, convenient and economical way to connect temporary emergency power from generators to a transfer switch.



LM-PIP400

Contents

- 2 Contents
- 3 Prior to Installation
- 3 Shipment: Unpacking and Inspection
- 4 Product Features
- 5 - 6 Installation
- 7 - 8 Set-up
- 8 Disconnecting Circuits
- 9 Limited Warranty
- 9 Maintenance
- 9 Technical Support

Appendices

- 10 Pre-Operation and Maintenance Checklist
- 10 Parts Dimensions
- 10 Represented Model Numbers and Ratings
- 11 Labels for Replacement

Important:

This manual contains information critical to the proper installation and operation of the Lex Products PowerGATE™ Power Input Panel. Be certain to read and understand all instructions prior to installation and operation.

NOTE: Must be installed in conjunction with a Transfer Switch provided by a source other than Lex Products.

This manual is furnished exclusively to support installation and operation of the Lex Products PowerGATE Power Input Panel. All concepts and ideas are the sole property of Lex Products and are not to be duplicated or utilized in any manner without written permission.

Prior to Installation: Site Preparation

Prepare installation site according to local codes.

The PowerGATE Power Input Panel is to be secured to a building using appropriate 3/8" fasteners (See Figure 1).

The surface where the PowerGATE Power Input Panel is to be secured must be capable of supporting the weight of the cabinet as well as the cable attached to it.

The following should be taken into consideration when locating the PowerGATE Power Input Panel:

- The PowerGATE Power Input Panel is designed for exterior operation ONLY
- Identify and meet local codes and local Authority Having Jurisdiction (AHJ)
- To prevent carbon monoxide poisoning from improperly ventilated generator emissions, the Power Input Panel must be mounted outdoors only. The mounting location is to be carefully selected to allow convenient connection to a generator, and located a suitable distance away from any building openings or HVAC inlets.
- Proper clearance must be allowed in front of the PowerGATE Power Input Panel to allow for opening of access doors and attachment of externally connected cables. This distance should be no less than six (6) feet from the face of the panel.
- While padlock protection is provided, access by unauthorized personnel and vandals should be taken into consideration when locating this device.

Shipment: Unpacking and Inspection

Note: Be careful in the use of sharp object when cutting packaging as damage to the outer enclosure may result.

Perform a visual inspection to ensure the door and all hasps are in functioning condition and that the panel integrity is intact.

Figure 1

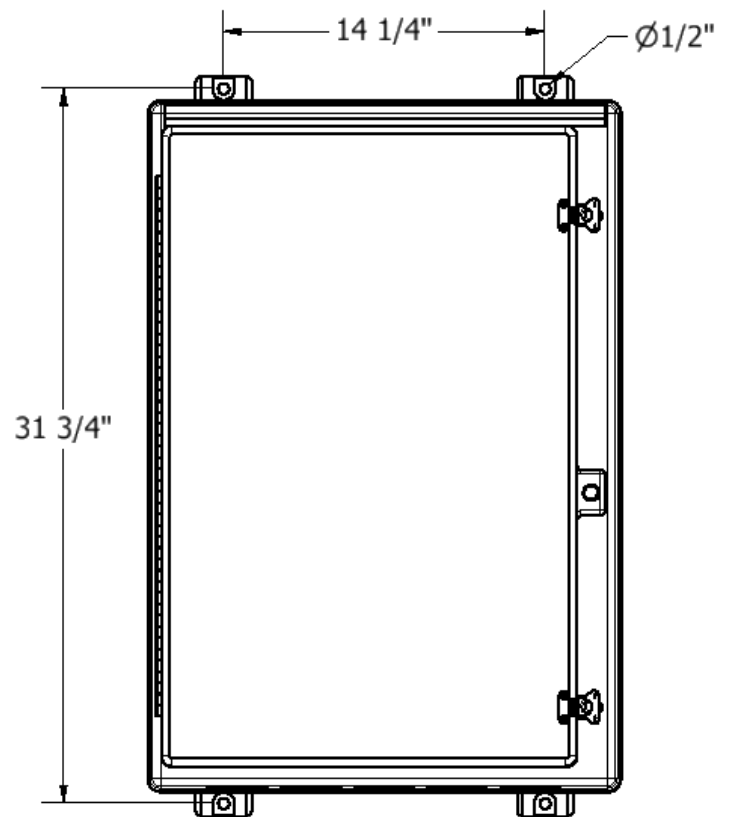

Front view with mounting holes

Product Features

Figure 2



Figure 3



Figure 4

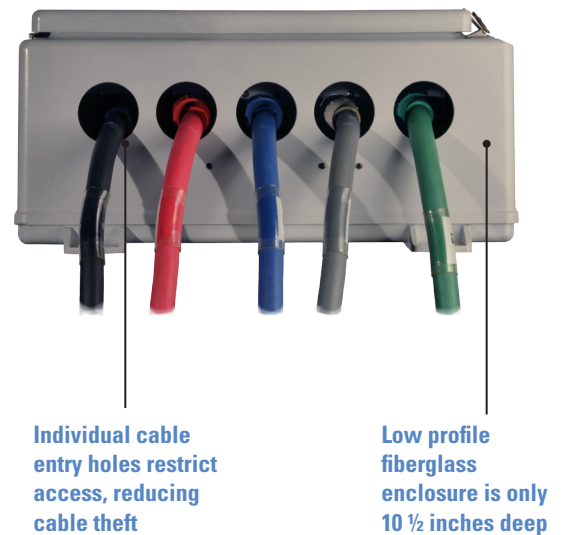

- Entire assembly is UL Listed NEMA 3R Rainproof
- Low profile
- Cables drape straight down
- Dead front panel prevents accidental contact with wiring chamber

Installation

The installation of the PowerGATE Power Input Panel should be carried out by qualified personnel in accordance with local electrical codes.

The PowerGATE Power Input Panel must be installed in conjunction with a transfer switch.

The transfer switch shall not have a rating greater than the PowerGATE Power Input Panel.

Step 1: Fasten the PowerGATE Power Input Panel to secure location

NOTE: The PowerGATE Power Input Panel weighs 58 lbs. without attached cables.

1. The panel should be located so there is adequate room for the externally connected cables to hang below the panel
 - A. Typically allow a minimum of 36" clearance from the bottom of the panel to finished ground level
2. Installation must be level and plumb to allow for proper drainage from PowerGATE Power Input Panel weep holes
3. Fastening onto an external wall using 3/8" fasteners must be completed prior to proceeding with any terminations (See Figure 1 for hole spacing)

Step 2: Installing the Conduit

NOTE: Conduit to enter through the top of the device (See Figure 5)

NOTE: To maintain TYPE 3R Rating compliance for the enclosure, proper sealing procedures must be followed. This is to include, but not limited to, the use of proper gaskets.

NOTE: In order to prevent enclosure damage and to attain the enclosure requirements, the conduit must be aligned to prevent unnecessary stress on the enclosure walls.

1. Open upper to door to expose dead front panel
2. Unfasten the dead front panel by removing the four (4) Phillips-headed 10-32 x 1/2" screws securing it (See Figure 6A and 6B)
3. Conduit to be sized according to cabling rating
4. It is recommended that a knockout punch be used to cut hole for conduit
 - A. Place the punch on the inside of the enclosure and draw the punch through to the die on the outside.
5. Vacuum entire upper chamber to ensure no shavings are left behind

Figure 5

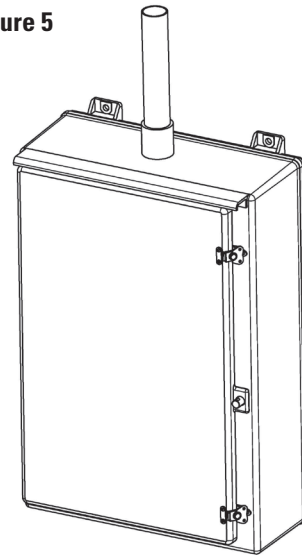

Figure 6A

FRONT VIEW W/ HINGED COVER REMOVED

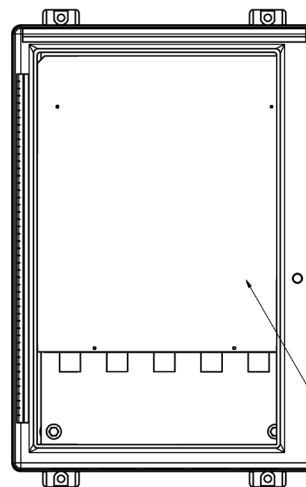
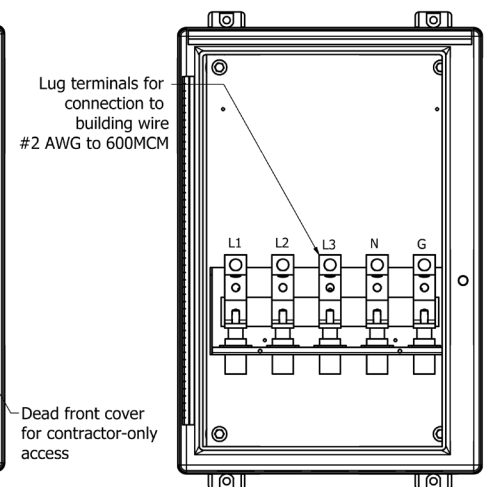

Figure 6B

FRONT VIEW WITH DEAD FRONT PANEL REMOVED

Lug terminals for connection to building wire #2 AWG to 600MCM



Installation – Continued

Step 3: Wiring the Lug Terminals

⚠ WARNING

Ensure circuit breakers are OFF and the transfer switch is locked out from utility power prior to connection.

Failure to install transfer switch will create the potential for the generator to energize utility lines and endanger utility personnel. Conversely, utility lines may energize the PowerGATE Power Input Panel and endanger generator personnel.

The PowerGATE Power Input Panel is for the connection of a generator to the source terminals of a transfer switch, such that the inlets are only energized from the generator.

1. Pull the cables for the transfer switch to the PowerGATE Power Input Panel
2. Beginning with the ground, strip and install the cables in the appropriate compression terminals

NOTE: The terminals can accommodate #2 to 600MCM, Copper wire only

3. Tighten terminal screws to 375 lb-in torque each
 4. If metallic conduit is used, connect ground wire from ground bushing on conduit to the ground connection point in the upper right quadrant of the panel
 - A. Ground conductor must be a minimum of #3 AWG
- NOTE:** Conduit shall NOT be relied upon to provide grounding protection to tap box
5. Continue to connect the neutral and then the phases
 6. Vacuum entire upper chamber to ensure no metal shavings are left behind
 7. Replace dead front panel door and secure using four (4) 10-32 x 1/2" Phillips-headed screws

⚠ WARNING

Three phase power systems consist of three phase or hot conductors that are shifted by 120 degrees. Three phase loads such as motors may only work properly if the phases are connected in the correct order. Some motors may work when connected improperly, but will operate backwards. Utility power and electrical generators may be wired either in a clockwise or counter-clockwise order. It is important that any generator connected to the PowerGATE input panel is connected in the same rotation (clockwise or counter-clockwise) as the utility power.

Step 4: Determine Phase Rotation

This information will be needed when connecting a generator.

1. Pull/Determine phase rotation of the utility power.
 - A. Connect a phase rotation meter to a three phase power source in the building and record whether the building is wired clockwise or counter-clockwise
2. Apply the provided label (Figure 7) to the inside of the PowerGATE Input Panel on the inside of the cam connection chamber door (Figure 8).

Figure 7

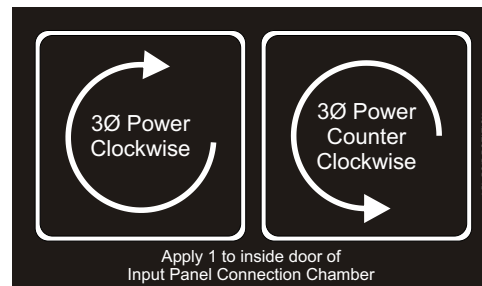

Lex Products Part Number – LBL-PGIP-ROTATION

Figure 8



Place rotation label here

Step 5: Conduct a safety test to ensure proper installation

Do not attempt to use the PowerGATE Power Input Panel prior to installation and completing the Pre-Operation and Maintenance Checklist under Appendix A.

Set-up

Step 6: Review Pre-Operation Checklist under Appendices A prior to operation (page 10)

⚠ WARNING

DO NOT ATTEMPT CONNECTION WHILE CIRCUITS ARE LIVE

- Do not use cables if they appear frayed
- Do not use cable if connectors or plug do not seat properly
- Do not use cables if any copper cabling is exposed
- To limit risk of shock, disable generator automatic start to prevent unintended starting

Step 7: Determining phase rotation of generator

1. Disconnect generator from all loads if needed
2. Connect a phase rotation meter to the output phases of the generator
3. Record generator phase rotation (clockwise or counter-clockwise)

Step 8: Making Cam Connections

1. Remove padlock, unsecure two (2) hasps and open chamber door
2. Feed ground (green) cable through appropriate port in bottom
3. Complete the connection

Proper connection (See Figure 9):

- A. Grasp connector jacket and firmly insert cam connector into cam plug
- B. Push on cam connector jacket until connector fully seats in cam plug
- C. Rotate cam connector jacket counterclockwise until it stops

Figure 9



4. Complete the Neutral (white) connection

Proper connection (See Figure 9):

- A. Grasp connector jacket and firmly Insert cam connector into cam plug
 - B. Push on cam connector jacket until connector fully seats in cam plug
 - C. Rotate cam connector jacket counterclockwise until it stops
5. Complete the Phase (hot) connections
 - A. Should the phase rotation of the generator (as determined in Step 7.3. above) and utility power (label found on the inside of the door for the Cam connection chamber) match, connect the Hots as follows:

Generator Hot	PowerGATE Power Input Panel Hot
A	A
B	B
C	C

- B. Should the phase rotation of the generator (as determined in Step 7.3. above) and utility power (label found on the inside of the door for the Cam connection chamber) NOT match, connect the Hots as follows:

Generator Hot	PowerGATE Power Input Panel Hot
A	B
B	A
C	C

Proper connection (See Figure 9):

- A. Grasp connector jacket and firmly insert cam connector into cam plug
 - B. Push on cam connector jacket until connector fully seats in cam plug
 - C. Rotate cam connector jacket counterclockwise until it stops
6. Make sure all connections are right and secure

Step 9: Close chamber door, secure hasps and replace padlocks, allowing cables to exit cable ports at bottom.

Set-up – Continued

Step 10: Powering Up

⚠ WARNING

Power **MUST BE** supplied from a single generator

1. Start generator per manufacturer instructions
2. Toggle the transfer switch, diverting power from utility to generator feed

Step 11: Disconnecting Circuits

⚠ WARNING

DO NOT ATTEMPT DISCONNECTING WHILE CIRCUITS ARE LIVE

1. To limit risk of shock, disable generator automatic start to prevent unintended starting
 - Remove padlock, unsecure two (2) hasps and open chamber door
 - Order of disconnect
2. Disconnect the Phase (hot) connections, beginning with the furthest to the left

Proper disconnection (See Figure 10):

- A. Grasp connector jacket firmly and rotate cam connector clockwise until it stops
 - B. Firmly pull on connector until it separates from the plug
 - C. Set aside
3. Continue with ALL Phase (hot) connections

4. Complete disconnect of ALL hot connections prior to proceeding
5. Disconnect the Neutral (white) connection.

Proper disconnection (See Figure 10):

- A. Grasp connector jacket firmly and rotate cam connector clockwise until it stops
- B. Firmly pull on connector until it separates from the plug
- C. Set aside

6. Disconnect the Ground (green) connections.

Proper disconnection (See Figure 10):

- A. Grasp connector jacket firmly and rotate cam connector clockwise until it stops
- B. Firmly pull on connector until it separates from the plug
- C. Set aside

Step 12: Close chamber door, secure hasps and replace padlock.

Figure 10



Limited Warranty

When this PowerGATE Power Input Panel is installed and operated according to the manual's instructions Lex Products will repair or replace any of its mechanical or electrical parts if they are found to be defective in material or workmanship within one year of the purchase date.

Maintenance

The PowerGATE Power Input Panel will require periodic maintenance. Lex Products recommends annual inspections to keep the panel in safe operating condition. Lex Products recommends that the Pre-Operation and Maintenance Checklist under Appendix A serve as a basis for annual inspection.

Technical Support

Lex Products technical services are available to assist in resolving issues by calling 1.855.LEX.1002 or emailing support@LexProducts.com. For any other information, please call Lex Products at 1.800.643.4460 or e-mail info@LexProducts.com.

Appendix A

Pre-Operation Checklist

1. Visual inspection of enclosure
 - Ensure the PowerGATE Power Input Panel is firmly secured to the building
 - Review conduit connection for signs of leakage
 - Ensure enclosure is intact with no signs of cracking
2. Open the chamber door
 - Ensure the chamber is dry and free of debris
 - Ensure that gaskets are pliable and no cracking exists
 - Ensure that door hinges are secure and lubricated
 - Ensure that hasps are intact and operational
3. Remove dead front panel
 - Ensure that all load terminals are securely fastened and that the set screws are set at 375 lb-in torque each
 - Ensure electrical connections are intact with no signs of corrosion or cracking
4. Review all safety labels and ensure that they are present and legible
 - See Appendix D for label nomenclature and location
 - Replace as needed
5. Inspect all portable cables
 - Do not use cables if they appear frayed
 - Do not use cable if connectors or plug do not seat properly
 - Do not use cables if any copper wiring is exposed
6. Lex Products technical services are available to assist in resolving issues. If you have any questions or need technical advice or suggestions regarding this product, please contact Lex Products at 203-363-3738 or e-mail support@LexProducts.com.

Appendix B

Parts Dimensions

Figure 11

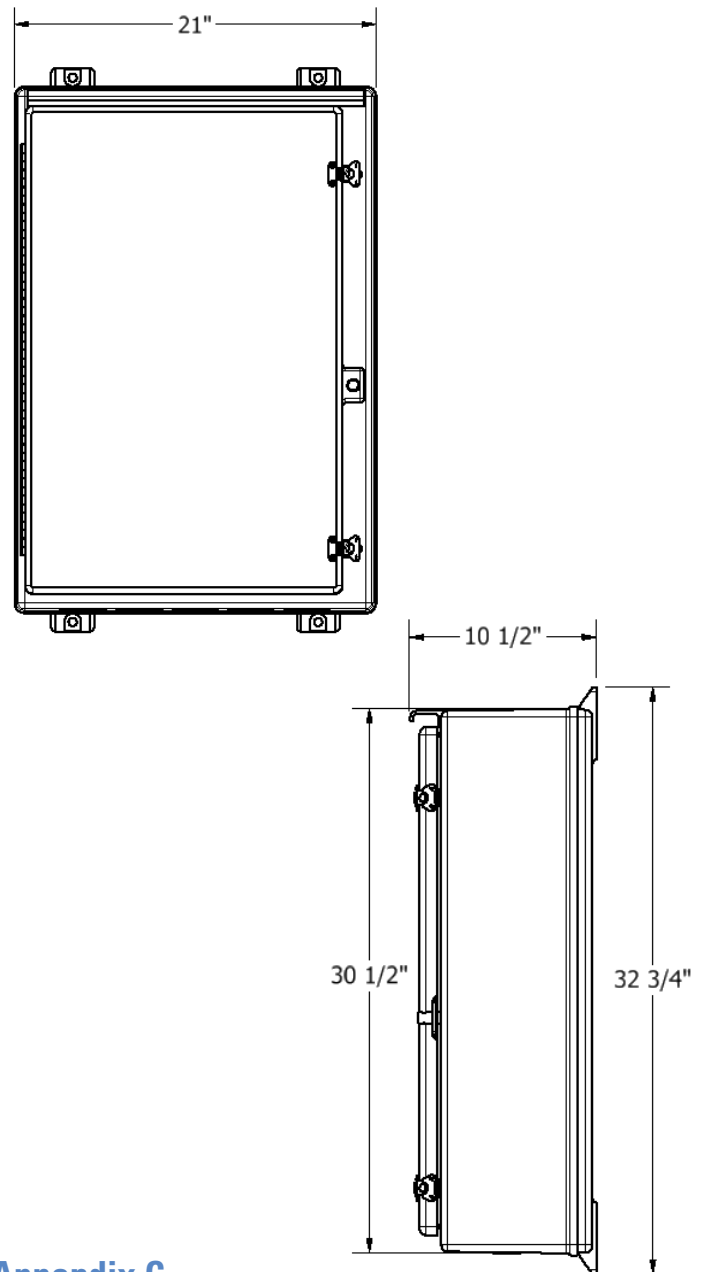

Appendix C

Represented Model Numbers and Ratings of Power Input Panels

Specific model numbers for 400 Amp Wye operation:
PIP400-C5M-3F-BRB
PIP400-C5M-3F-BOY

Appendix D

Labels for Replacement



Lex Products Part Number – LBL-PGIP-D1

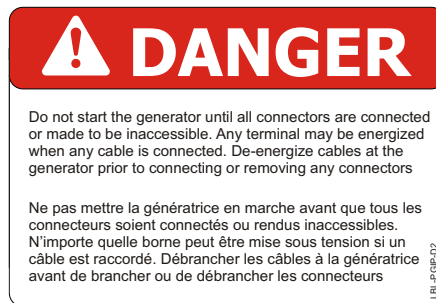

Lex Products Part Number – LBL-PGIP-D2

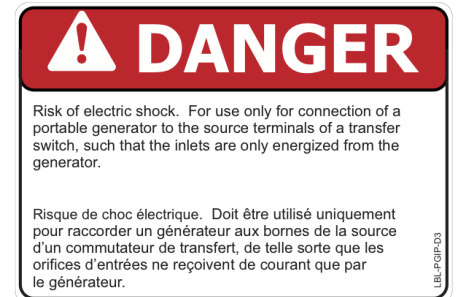

Lex Products Part Number – LBL-PGIP-D3

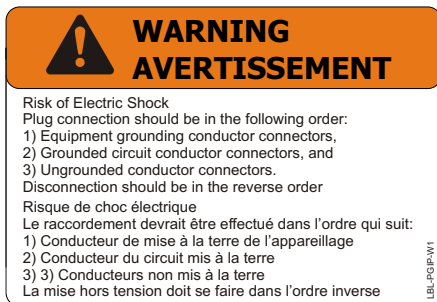

Lex Products Part Number – LBL-PGIP-W1

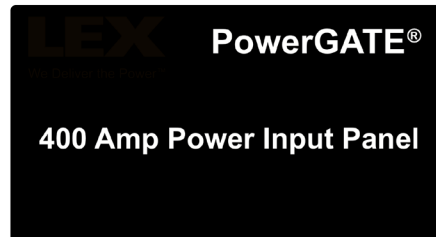

Lex Products Part Number – LBL-PGIP-400

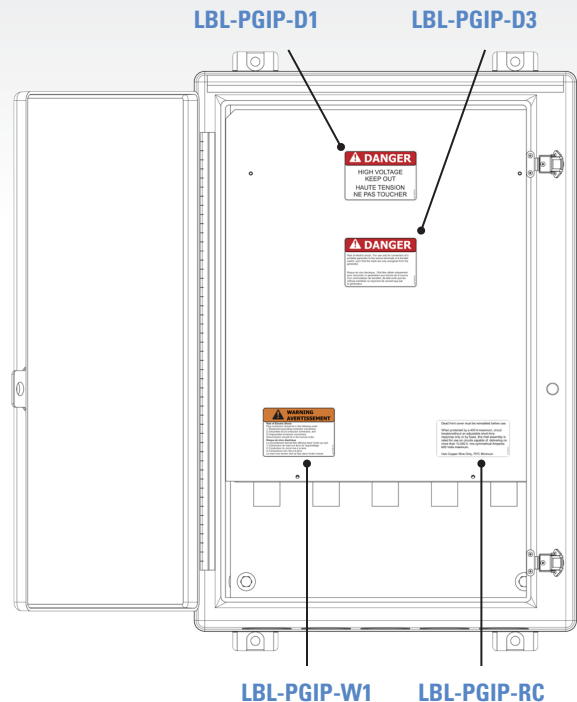
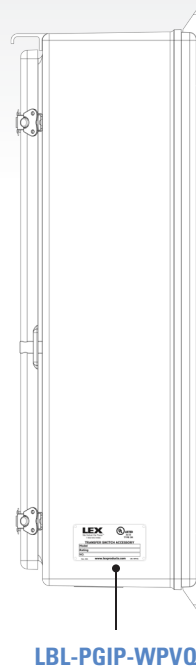
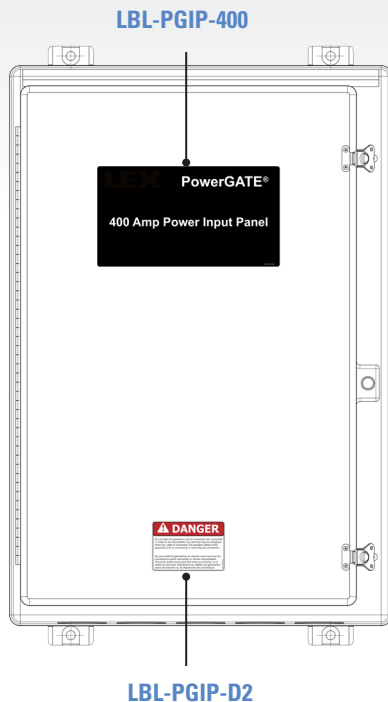

PowerGATE™ Power Input Panel User Manual for 400 Amp Transfer Switch



TYPE 3R Rainproof

Ordering information

Part Number	PIP400-C5M-3F	PIP400-C4M-3F
Rating	400 Amp, 3 Phase (H,H,H,N,G), 4 Pole, 5 Wire, 600 VAC Maximum	400 Amp, 3 Phase (H,H,H,G), 3 Pole, 4 Wire, 600 VAC Maximum
Environmental Rating	TYPE 3R Rainproof	TYPE 3R Rainproof
Input	(1) Set of (5) 16 Series Cam-type color coded panel mount inlets	(1) Set of (4) 16 Series Cam-type color coded panel mount inlets
Output	Direct Wire	Direct Wire
Enclosure	Fiberglass	Fiberglass
Dimensions	30.75" H x 10.5" D x 21" W	30.75" H x 10.5" D x 21" W
Approximate Weight	58 lbs	57 lbs

BRB (Black, Red, Blue), BOY (Brown, Orange, Yellow), BBB (Black, Black, Black) and RGN (Reverse Ground Neutral) Cam options available. Contact a Lex Products Sales Representative for more information



Lex Products Corporation
15 Progress Drive
Shelton CT 06484
203.363.3738
203.363.3742 Fax

Lex West
11847 Sheldon Street
Sun Valley, CA 91352
818.768.4474
818.768.4040 Fax

www.lexproducts.com
info@lexproducts.com
800.643.4460

© Copyright Lex Products 2013

Produced in the United States of America
All Rights Reserved.

Lex Products logo and lexproducts.com are trademarks or registered trademarks of Lex Products in the United States, other countries, or both.