

Silverpak 17C/CE

INTEGRATED STEP MOTOR, DRIVER AND CONTROLLER

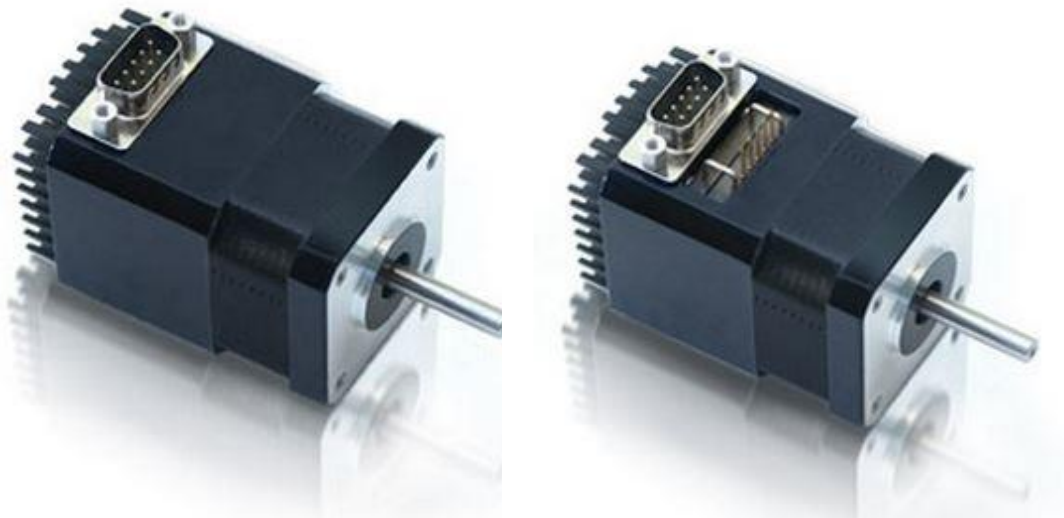

With Encoder Option

Thank you for purchasing the Silverpak 17C or 17CE integrated motor and controller with microstepping driver. This product is warranted to be free of manufacturing defects for one year from the date of purchase.

PLEASE READ BEFORE USING

Before you begin, ensure there is a suitable (+12V to +40V) DC Power Supply. **Do not disconnect the DB-9 cable while power is still being applied to the controller.** This will damage the board. Do not exceed +40 VDC.

DISCLAIMER

The information provided in this document is believed to be reliable. However, no responsibility is assumed for any possible inaccuracies or omissions. Specifications are subject to change without notice.

Lin Engineering reserves the right to make changes without further notice to any products herein to improve reliability, function, or design. Lin Engineering does not assume any liability arising out of the application or use of any product or circuit described herein; neither does it convey any license under its patent rights, nor the rights of others.

Special Symbols



Indicates a WARNING and that this information could prevent injury, loss of property, or even death (in extreme cases).

Silverpak 17C/CE User Manual

Product: Silverpak 17C and 17CE
Version: 1.10
Date: 5/20/2015

Version History		
Version	Date	Description of Changes
1.00	04/10/2006	New User Manual
1.01	08/07/2006	Updated specs
1.02	08/18/2006	Updated specs
1.03	02/01/2007	Standardization of all user manuals
1.04	11/02/2007	Updated description of RMS vs Amp Peak current, and explanation of I/O's
1.05	12/14/2007	Updated designer kits, connections & HyperTerminal instructions
1.06	4/3/2009	Added new RoHS RS485-232 card info
1.07	9/16/2009	Updated image for LED connection.
1.08	10/7/2009	Updated RS485 info.
1.09	10/29/2009	Added full stepping as a resolution option.
1.10	5/20/2015	Replaced Hyper Terminal with LinCommand

TABLE OF CONTENTS

1. FEATURES	5
<i>Designer's Kit with USB communication</i>	5
<i>Designer's Kit with RS232 communication</i>	5
<i>Default Settings</i>	6
2. ELECTRICAL SPECIFICATIONS	6
<i>Digital I/O Specifications</i>	6
<i>Motor Specifications</i>	6
3. OPERATING SPECIFICATIONS	6
<i>Communication Specifications</i>	6
4. MECHANICAL SPECIFICATIONS	7
<i>Dimensions</i>	7
<i>Silverpak 17CE Encoder Pinouts</i>	8
5. PIN ASSIGNMENTS	8
<i>Connecting to the USB card</i>	9
<i>Connecting to the RS232 card</i>	9
6. CONNECTION SPECIFICATIONS	10
<i>Quick Start</i>	10
<i>USB-485 converter card</i>	10
<i>RS232-485 converter card</i>	11
<i>Mating Connectors</i>	11
7. CONFIGURING AND CONTROLLING THE SILVERPAK 17C	12
<i>LinCommand Setup</i>	12
<i>Setting the Current</i>	13
<i>Connecting Multiple Silverpak17C's</i>	14
<i>Changing the Address of the Controller</i>	15
<i>Connecting Accessories</i>	15
<i>Push Button</i>	15
<i>LED or other output</i>	16
<i>Optical Sensor</i>	17
8. Troubleshooting & FAQ	19
9. Appendix	21
<i>Connecting to the old non-RoHS RS232 card</i>	21
<i>Peak current versus Amps/Phase</i>	22

1. FEATURES

- NEMA 17, 1.8° step motor integrated with R256 controller/drive
- Operates from +12V to +40V DC
- Single 2 wire bus linking up to 16 stepper motors via RS485
- 2.0 Amp Chopper (PWM) Driver
- Full, 1/2, 1/4, 1/8, 1/16, 1/32, 1/64, 1/128, 1/256 step resolution
- Stand alone operation with no connection to a PC
- Execution Halt pending switch push button
- Internally Pre-wired for Opto Switch inputs
- Homes to an Opto or Switch closure with a single command
- Fully programmable ramps and speeds
- Two digital I/O and two fixed input channels
- Switch selectable address
- Software selectable "Move" and "Hold" currents
- Hold Current automatically selected upon move completion
- Simple DB9 connection

Designer's Kit with USB communication

Here is the list of components if you have purchased the optional Designer's Kit:

- USB to RS485 converter card
- A switch push button
- Opto Sensor
- A USB 6 foot long cable

Lin part number: USBKIT

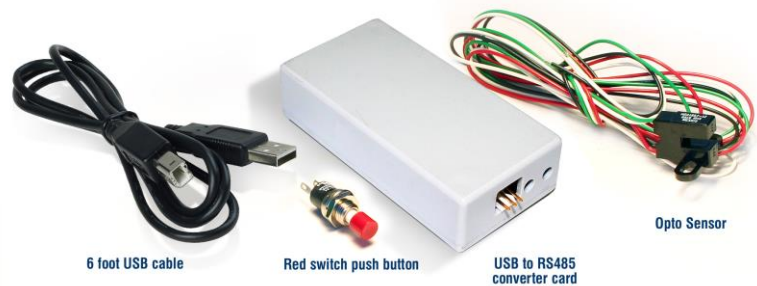

Designer's Kit with RS232 communication

Here is the list of components if you have purchased the optional Designer's Kit:

- RS232 to RS485 converter card
- A switch push button
- Opto Sensor

Lin part number: RS232KIT

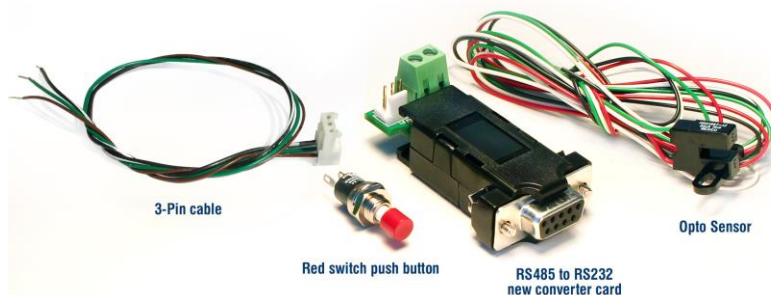

Default Settings

Function (command)	Description
Running Current (m)	30% of 2.0 Amps
Holding Current (h)	10% of max current of 2 Amps
Step Resolution (j)	256x
Top Velocity (V)	305175 pps (microsteps/sec)
Acceleration (L)	L=1000, 6103500 μ steps/sec ²
Microstep smoothness (o)	1500
Outputs (J)	Both are turned off, J0
Baud Rate	9600 bps

Table 1: Default Settings

2. ELECTRICAL SPECIFICATIONS

Supply Voltage: +12 to +40 VDC
Peak Current: 0.1 to 2.0 Amps

Digital I/O Specifications

Number of I/O 2
Number of Inputs 2
Input Voltage +0 VDC to +5 VDC (0 to 24V tolerant, but 5V recommended)
Input Current 700 mA
Pull-up Resistors 10k Ω
Protection Static Protection to the microprocessor
LED output (Pin 9) max of 20mAmps, with 200 ohm internal resistor

Motor Specifications

Any 4118 series step motor that is rated at 2.0 Amps/Phase or less can be combined into a Silverpak 17C or CE product. General torque specifications are listed below:
(In some circumstances, motors rated above 2 Amps, *may* be used, with a de-rated torque.)

Holding Torque (max of 1.0 Amp Holding Current, winding specific)
CO-4118S 20 to 45 oz-in
CO-4118M 30 to 63 oz-in
CO-4118L 40 to 80 oz-in

Micro step size	1	2	4	8	16	32	64	128	256
Steps per Revolution	200	400	800	1600	3200	6400	12800	25600	51200

3. OPERATING SPECIFICATIONS

Maximum Step Frequency 2[^]24 (pps) or 16.7MHz
Operating Temperature Range 0° to 50° C
Storage Temperature Range -20° to 70° C

Communication Specifications

Interface Type RS485 (RS232 or USB with a converter card)
Baud Rate 9600, 19200, or 38400 bps
Bits per character 8 Data
Parity None
Stop Bit 1
Flow Control None

4. MECHANICAL SPECIFICATIONS

Dimensions

- A.** DB-9 connector for I/O, Power and Communication
- B.** Motor Shaft Length: standard length is 0.94". Customized length is available.
- C.** Motor Shaft Diameter: standard shaft diameter is 0.1968". Customized diameter is available.
- D.** Overall Body Length: Motor body length is available in various lengths
Model CO-4118S (2.69")
Model CO-4118M (2.92")
Model CO-4118L (3.24")
- E.** Encoder pins (encoder optional)

Dimensions / Encoder Pinouts(SilverPak17CE only)

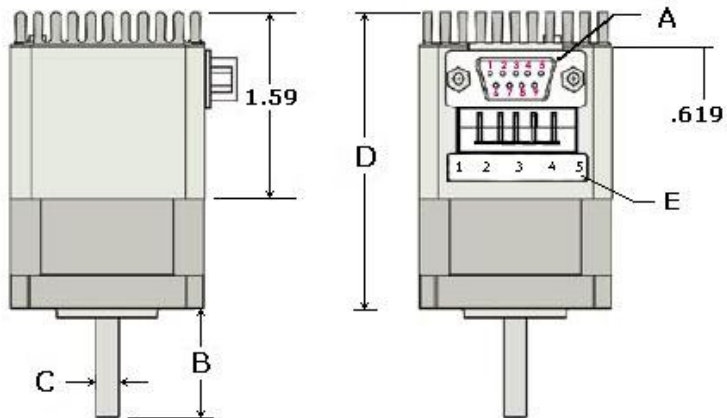
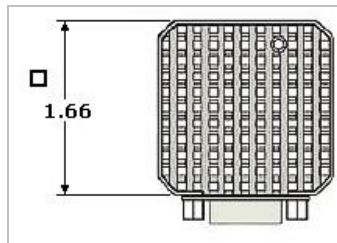

****Index is optional and must be specified during ordering***

Silverpak 17CE Encoder Pinouts

NOTE: This is not a closed loop system. The encoder does not feedback to the controller. A separate PLC or controller must be used to communicate between this controller and this encoder.

- A choice of 32 to 1250 cycles per revolution (CPR)
- 2 Channel Quadrature
- TTL Squarewave Outputs
- Optional index (3rd Channel)
- E2 US Digital Encoder

Pin Number	Function
1	Ground
2	Index
3	Channel A
4	+ 5 VDC
5	Channel B

Table 2: Encoder Pinouts

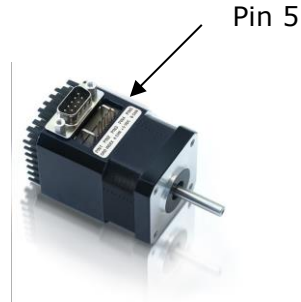

5. PIN ASSIGNMENTS

A DB-9 female connector cable receives power and provides the control connections for the Silverpak17C. The DB-9 cable has a 3 pin connector provided for the converter card in order for the controller to communicate with the PC via a USB-485 converter card or RS232-485 converter card. Other wires allow the user to solder and program the switch push button and the Opto Sensor, enabling several options. The I/O's will allow for options such as solenoids, relays, opto isolators, LED's and many other input and output connections. See Table3 below for details.

Pin #	Color	Function	Input*
1	Red	+V (Main Power In)	
2	Black	I/O	1
3	Brown	RS485B (+)	
4	Black/White	RS485A (-)	
5	Orange	Switch Closure to GND (IN)	4
6	Green	GND (-V of main power in)	
7	White	Opto Sensor Phototransistor (IN)	3
8	Blue	I/O	2
9	Yellow	Opto Sensor LED (Power Out)	

Table 3: Pin Assignments

*Inputs are labeled 1, 2, 3 and 4 for programming the 'Halt' and 'Skip' Commands.

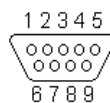
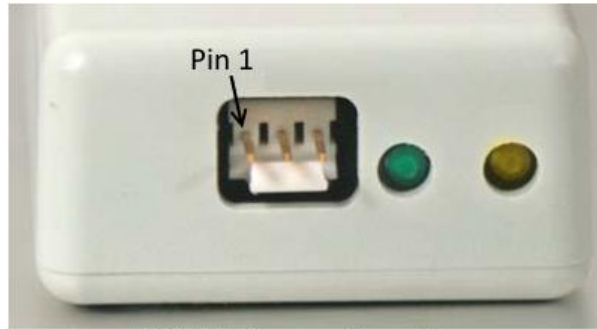

Figure 1: DB-9 Female Cable Connector (Rear View)

Connecting to the USB card

SP17C pin#	SP17C color	USB-485 pin#
4	Black/white	1 (RS485A)
6	Green	2 (GND connect to Power Supply Ground)
3	Brown	3 (RS485B)

Table 5



RS485 Connection View

Figure 3

The USB converter card does not require power (it receives power from the PC). Power is still needed for the R256 controller/driver.

Connecting to the RS232 card

SP17C pin#	SP17C color	RS232-485 pin#
4	Black/ White	1 (RS485A)
6	Green	2 (GND connect to Power Supply Ground)
3	Brown	3 (RS485B)

Table 4

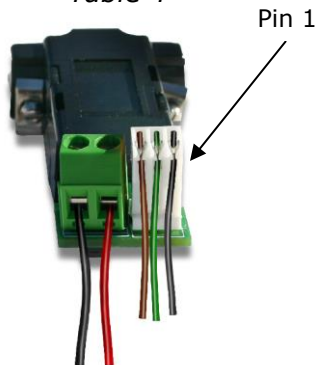

Figure 2

The RS232 card requires power (7-40VDC)



6. CONNECTION SPECIFICATIONS

Quick Start

DO NOT PLUG IN POWER UNTIL EVERYTHING IS CONNECTED.

USB-485 converter card

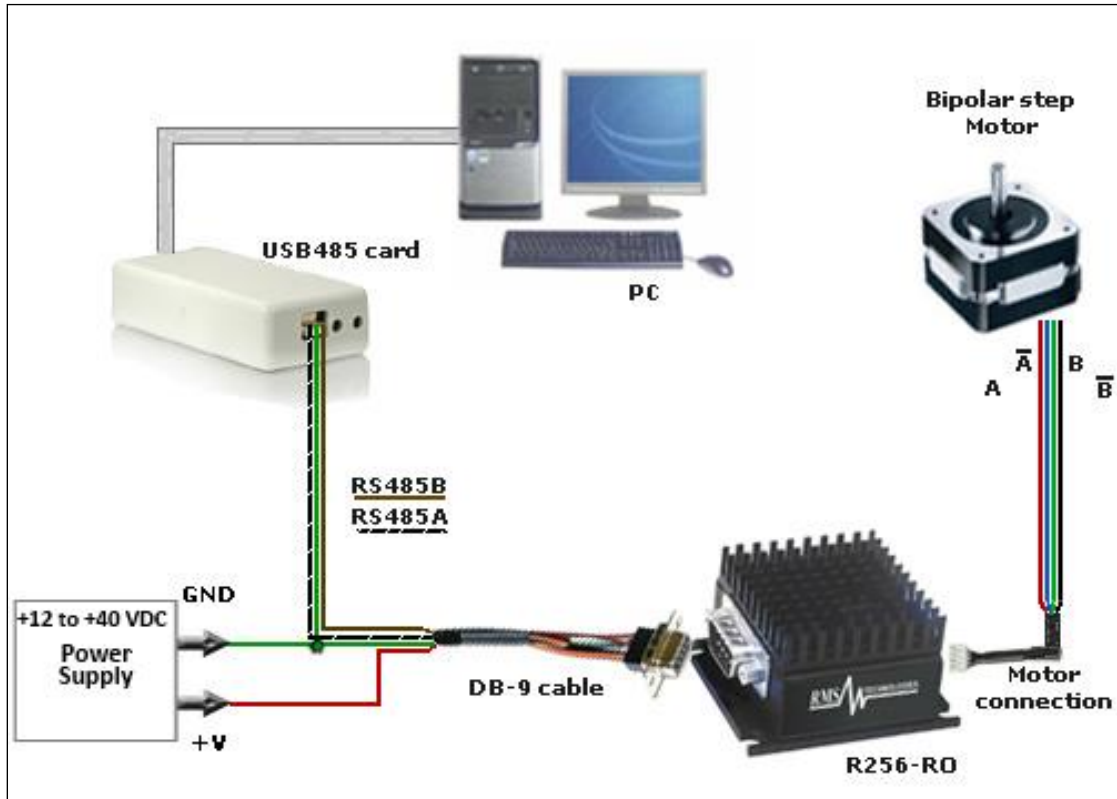

(Figure 5)

1. The USB converter card connects to the Silverpak using the DB-9 cable that is provided to you. The 3-Pin connector is placed onto the USB converter card.
2. Your power supply will be connected to the Silverpak directly. The USB card is powered via the PC. **Silverpak's pin-1, Red wire is +12 to +40VDC. Pin-6, Green wire is Ground.**
3. Connect the USB card to your PC using the USB cable provided to you. You will need to download driver by selecting the 'Download' tab at: <http://www.linengineering.com/accessories/USB485.aspx>
4. Turn your power supply on and follow instructions for using LinCommand.

RS232-485 converter card

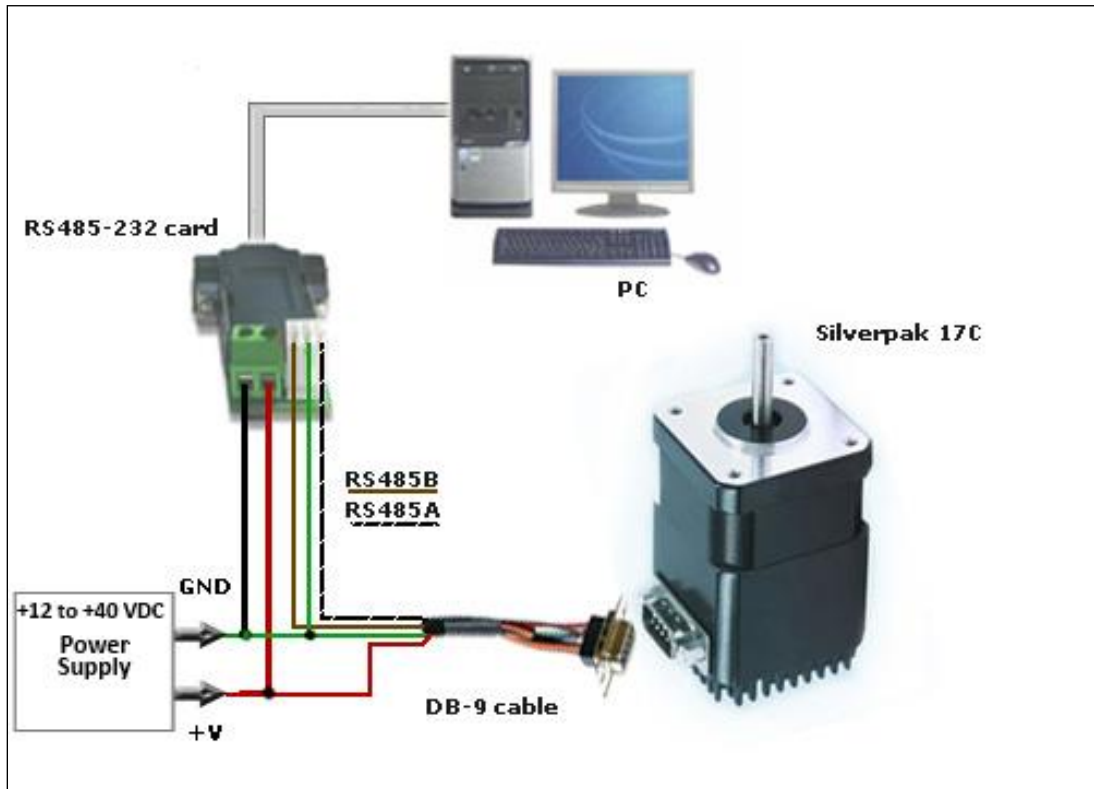

(Figure 4)

1. The RS232 converter card connects to the Silverpak using the DB-9 cable that is provided to you. Opposite the DB-9 cable is a 3-Pin connector which is placed onto the converter card.
2. Your power supply will be connected to the RS232 card where the green header is located. The "+" is for **+12 to +40VDC**. The "-" is for the **Power Supply Ground**. **The Silverpak must also be powered via Pin-1 (red wire for Power) and Pin-6 (Green for Ground).**
3. Connect the RS232 card to your PC with a male to female DB-9 cable.
4. Turn your power supply on and follow instructions for using Lin Command.

Mating Connectors

A DB-9 cable is provided with every SilvePak17C motor. The opposite end has flying leads and a 3-pin connector for RS485 communication.

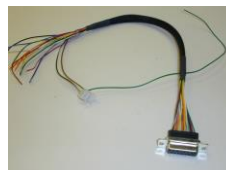

Lin Part # 90-044

7. CONFIGURING AND CONTROLLING THE SILVERPAK 17C

LinCommand Setup

For more detailed instructions, please refer to the LinCommand Manual.

Follow these steps to set up and use LinCommand:

Note: If LinCommand has not been installed on your computer, you may download the program in 32 Bit or, 64 Bit, from the link below. After downloading, navigate to the 'Setup' file and double click 'Setup' to install.

<http://www.linengineering.com/resources/download.aspx>

1. After installation, double click on the LinCommand icon , to launch the LinCommand program.
2. Choose R256 from the drop down box and then click [OK].
3. LinCommand opens in 'Normal' mode with a GUI interface to control the stepper motor. For Advance mode, skip to step 8 below.
4. To continue in the 'Normal' mode, choose your COM port, baud rate, and controller address (See Figure 8) and then click [Connect],
Note: if you are using the USB485 converter card, first download & install driver files for the USB485
5. Choose the 'Motor Settings' tab. Set the Run Current*, Hold Current, Step Resolution, Velocity, and Acceleration then click [Add Settings to Queue].



* **CAUTION** Do Not Exceed Motors Peak Current or,

Damage to the Motor and Controller Could Result! See "**Setting the Current**" on following page.

6. Double click on the "**Click Here to Add Command**" to bring up the motor control menu.
7. For more instructions, please refer to the LinCommand Manual.
8. To operate in the 'Advanced mode', Choose 'Options' and select 'Advanced mode'.
9. Select your COM port and baud rate, then click [Connect].
10. Enter command strings on one of the 7 lines in the 'Send' window and click 'Send' to send the adjacent command line to the controller.
11. For a complete list of commands and their definitions refer to the R256 Commands manual.

Example command: /1A1000R

- This will run unit #1 to the Absolute position 10000
- You can check the address of your driver by checking the dial at the top of the driver. (See the following page for Changing the Address)
- A full list of commands is available in the Silverpak 17C / R256 Command List
- Most common commands to change are:
 - Step resolution (/1j2R sets it to half stepping)
 - Velocity in pulses/sec (/1V1000R sets the speed to 1000 pps)
 - Run current (/1m30R sets the run current to 30%)
 - Hold current (/1h10R sets the hold current to 10%)
 - Move the motor (/1P800R moves the motor 2 revs if half stepping)

Responses:

?/0@ indicates good command and that it was received correctly
?/0b indicates bad command
?/0C indicates that the command is out of range
?/0` indicates that the command is terminated
?/0`a Overflow

Setting the Current



CAUTION! DO NOT SET THE CURRENT ABOVE THE MOTOR'S RATED CURRENT.

In order to set the correct current for your motor, you must program the specified current in LinCommand (or whatever software program is being used).

Current is set based on the Maximum amount of current the controller board can output, which is 2.0 Amps Peak. Drivers are Amps-Peak, motors are Amps/Phase. Below is a table of how much current will be applied to your motor for each setting.

Percent	Command		Motor's Current Rating (Amps/phase)	Driver's Equivalent Current (Amps Peak)
10%	m10	=	0.14	0.20
20%	m20	=	0.28	0.40
30%	m30	=	0.42	0.60
40%	m40	=	0.57	0.80
50%	m50	=	0.70	1.00
60%	m60	=	0.85	1.20
70%	m70	=	0.99	1.40
80%	m90	=	1.13	1.60
90%	m10	=	1.27	1.80
100%	m100	=	1.41	2.00

Table 6: Desired Current

To achieve the equivalent Driver Current (Amps Peak), multiply the motor's rated current by 1.4. Follow these examples:

Example One:

You have a motor that is rated at **0.85** Amps, $0.85 \text{ Amps} \times 1.4 = \sim 1.2 \text{ Amps}$. Using *Table 6* we would see that 1.2 Amps is 60% of the driver's maximum output current.

Assuming the Silverpak is addressed to Number 1, this is what you'd program:
`/1m60R`

Example Two:

You have a motor that is rated at **1.0** Amps, and your Controller is addressed to Number 1, this is what you'd program: `/1m70R`

This will set the controller to 1.4 Amps Peak. How did we get 1.4 Amps? $\rightarrow 1.0 \text{ Amps} \times 1.4 = 1.4 \text{ A}$

See page 21, "Peak current versus Amps/Phase" for a detailed explanation.

WARNING!: Setting the Current to a value greater than the Motor's rated current will damage your motor, and may overheat the controller.

Connecting Multiple Silverpak17C's

If using the **USB485** converter card, connect all the power and ground lines on the units to the main power supply. Then daisy chain the RS485+ and RS485- lines prior to plugging into the USB485 card. Be sure to also ground the USB485 card with Pin 2, ground. **All connections must be completed BEFORE applying power.**

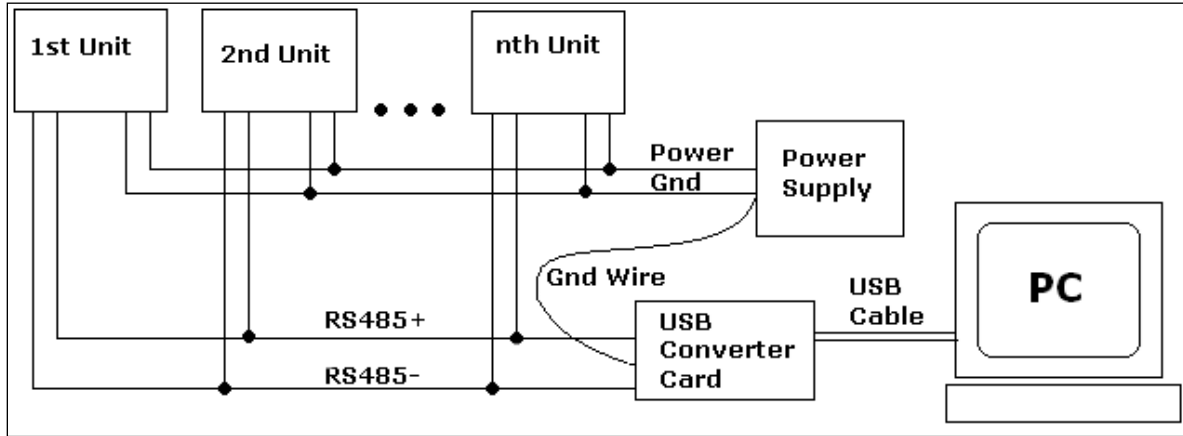

Figure 7: Connection using USB485Converter Card

If using the **RS232-to-RS485** converter card, daisy chain all four wires: power, ground, RS485+ and RS485- prior to plugging into the converter card.

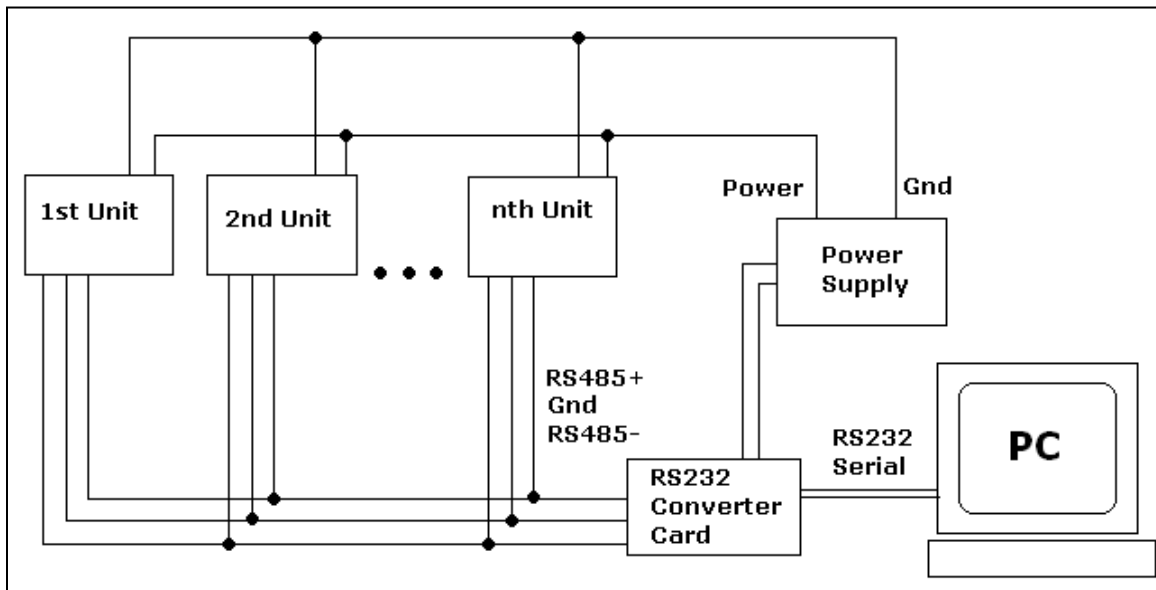

Figure 6: Connection using RS232 Converter Card

Changing the Address of the Controller

Use a small Philips screwdriver to turn the dial so the arrow points to the desired Address. Use this number when programming commands. For example, /1P1000R



Figure 8: Address Dial

Connecting Accessories

If you have purchased the Designer's Kit, there is a Red Push Button and an Optical Sensor included. Follow the schematics below in order to properly assemble accessory pieces.

Push Button

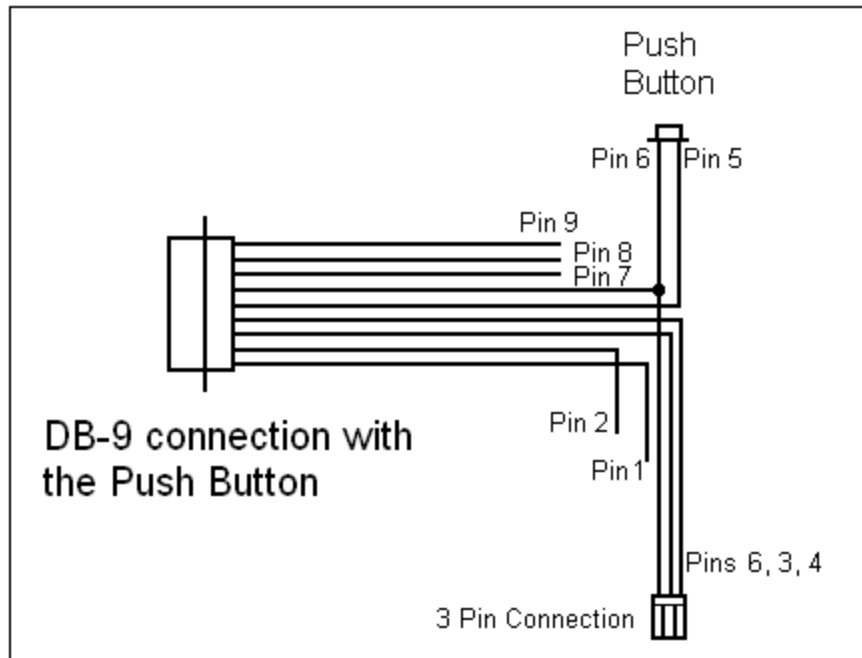

Figure 9: Push Button Schematic

It is best to solder the Push Button to Pin 5 which corresponds to Input 4, then solder Pin 6 (Power Ground) to the other side of the push button.

Input 1	Pin 2 (Black)
Input 2	Pin 8 (Blue)
Input 3	Pin 7 (White)
Input 4	Pin 5 (Orange)

Table 7

Any of the four inputs can be connected to a push button. In our example above, pin 5 corresponds to input #4, therefore, if you want to program the motor to wait until this button is pressed in order to begin movement, your program would look something like this:

```
/1H04P50000R
```

H04 means to Halt until it sees a low, or 0, on input #4
P5000 move the motor in the positive direction by 5000 steps
R is to run this string of commands

The motor should send the command P5000 once the button has been pressed, otherwise, it will continue to wait at "H04"

LED or other output

The two I/O lines, pins 2 & 8, can drive an external device such as solenoids, LED's, or switches. The bidirectional I/O's are switches to ground internally, and therefore need to be connected to the +V of the power supply. Below is a recommended connection for lighting an LED with 20m Amps:

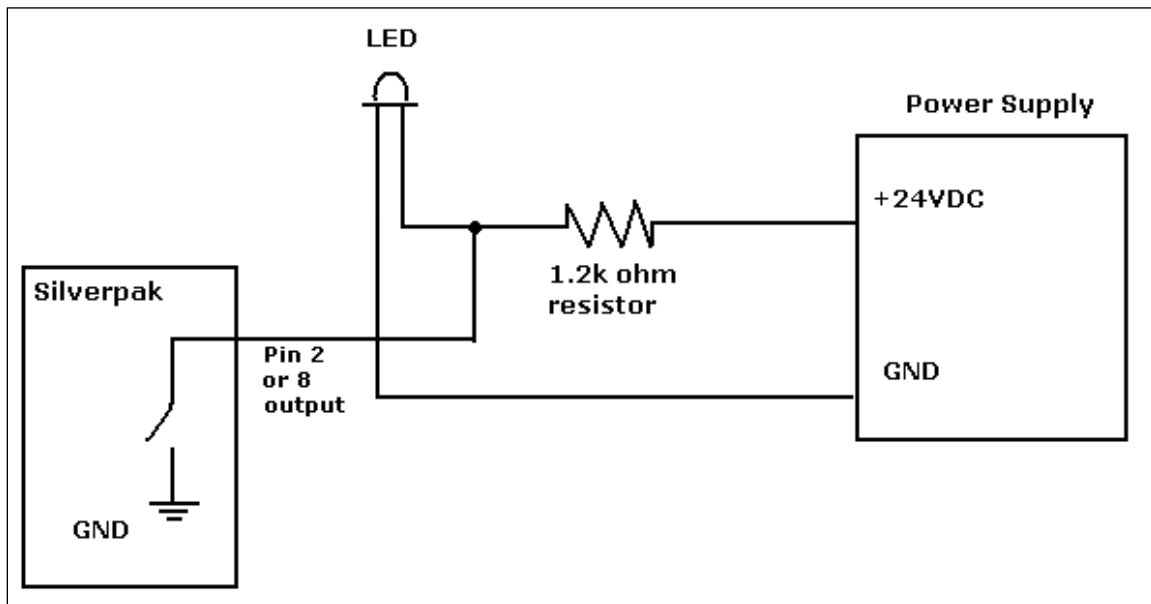

Figure 10: LED Connection Schematic

Upon entering command /1J0R, both pins 2 & 8 will output 1 Amps. The 1.2k ohm resistor will limit the current to 20m Amps into the LED. Select any ohm value to limit your current based on the device that is connected to the output.

I/O's are 24VDC tolerant.

Optical Sensor

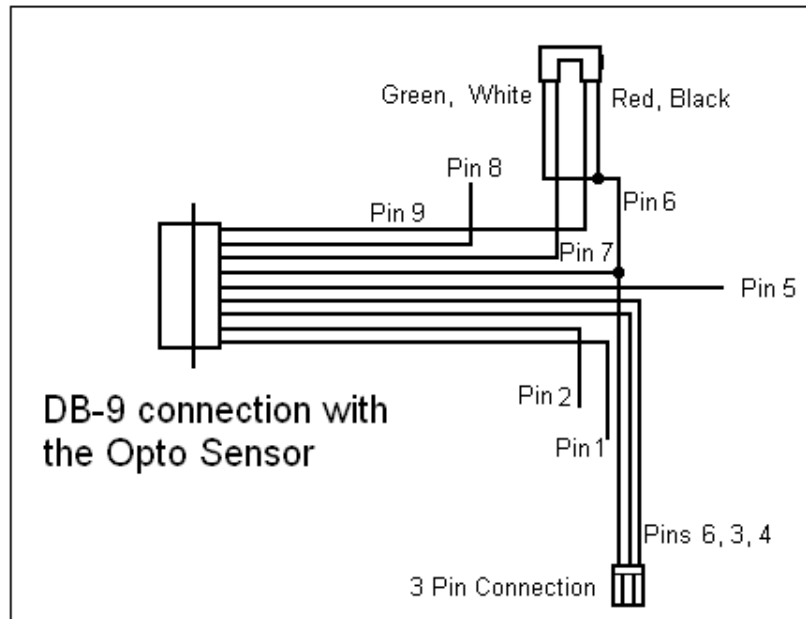

Figure 11: Opto Sensor Connection Schematic

The Opto Sensor uses Pins 6, 7, and 9. Use the following table to solder the corresponding wires.

Optical Sensor	DB9 Cable	Pin
Green →	Green	6
Black →	Green	6
Red →	Yellow	9
White →	White	7

Table 8

To home to your optical sensor, use the Z command and state the max number of steps you want it to search for home. The unit will either stop at the opto sensor or when it finishes moving your designated number of steps. For example:

```
/1Z500000R
```

Motor will take 500,000 steps and stop OR Motor will stop once the optical sensor has been interrupted. Only input #3 can work with the optical sensor.

The LED output on pin 9 can output a max of 20mAmps (200 ohms internal resistor and 5VDC output)

Encoder Usage

The Silverpak 17CE **is not a closed loop system**. The encoder does not connect to the controller/driver. A separate PLC or controller system that can talk to the R256 board and understand the E2 encoder can create a closed loop system.

The Silverpak 17CE can also be used as reference to home by connecting to an US Digital E2 Encoder. The pinouts are as follows:

Pin Number	Function
1	Ground
2	Index
3	Channel A
4	+ 5 VDC
5	Channel B

Table 9

The E2 encoder requires a separate +5 Volt power supply, as the Silverpak17CE cannot provide a strong enough source of power.

In order to use the Indexer as a reference to home, connect Pin 2 from the encoder to one of the inputs on the controller. From the controller's side, for best results use Pin 5, the switch closure to ground.

In addition, use a pull-down resistor (10k Ω) to ensure that the controller will recognize the difference between high and low (4.85V and 0.5V).

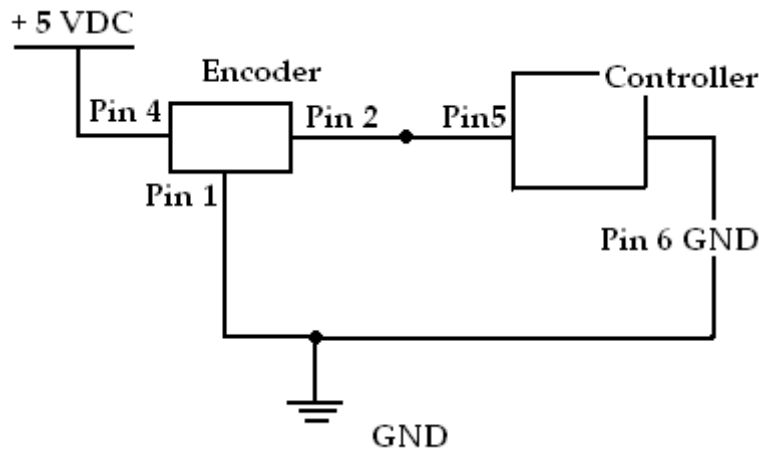

Figure 12: Encoder Pin Connection Schematic

After successfully connecting the encoder to the controller, now you can program the controller to run continuously. The motor will stop movement when the indexer goes high. This will send the high signal to Pin 5 on the controller.

If using channel 1, use this command to start the homing routine:

`/1POR`

8. Troubleshooting & FAQ

Communication problem between computer and controller:

Is the correct COM Port selected? Use an operating system of Windows 98 or higher. Are you working on a Laptop? Sometimes there is a shift in Ground on Laptop Serial Ports. Pin 5 on the Serial Port is Ground. Make sure that this is connected to a true ground.

Is the LED flashing on the bottom of the Silverpak17C? A flashing light indicates it is waiting for Commands and power is OK. Motor shaft should be difficult to rotate.

Check the Converter Card. Use a voltmeter to measure if Power is coming into the card correctly and if power is being supplied to the Controller properly.

Can communicate with LinCommand, but no motor movement:

Check the LED on the back of the Silverpak 17C. If there is no LED lit, the problem may be the Power Supply, check the connections. If you see one LED that flashes on and off about 5 seconds at a time, then power is OK.

Is the Silverpak17C set to the correct Address? Check the Dial on the bottom of the unit. The arrow should be pointing to the corresponding Address. Make sure that the arrow is not between 2 Addresses. Use a small screw to verify that it clicks in place.

Check the Converter Card. Use a voltmeter to measure if Power is coming into the card correctly and if power is being supplied to the Controller.

Note the description of the following response strings.

/O'□ indicates that the command is terminated

/O@□ indicates good command and that it was received correctly

/OC□ indicates that the command is out of range

/Ob□ indicates bad command

The unit is by default, set to 256 microsteps. Therefore, by typing in a position move of /1P200R, you will not see anything. It takes 51,200 steps to make one revolution, so try a large value, like /1P100000R

Silverpak 17C will accept commands, but the Motor will stall in the middle of a command:

This means there is not enough current being supplied to the Motor. Use the m command to change the current, or run the Motor at a Lower Speed (V command). Or, make the motor accelerate slower using the L command.

Halt Command (H01) Issues

There are known issues involving the Halt command (i.e., H01) when stored in memory location zero. Upon power up, the remaining command string after the Halt command might be executed if the user types in a new command. If memory location zero is not being used, the user is advised to always clear everything in memory by typing /1?9. Otherwise, the user may terminate the remaining command string in the buffer by issuing a /1T.

I want to use one of the I/Os to turn on a LED to confirm that the motor has finished moving or moved to a certain position. How do I do it?

To turn on a LED to confirm that the motor finished moving you must use the "J" command in the command list section On/Off Drivers. We are assuming the unit executes the command sent. We cannot detect skipping because the set up is open loop. Example: /1P200J10R, is a position move 200 steps, then turn on driver 2. See Figure 10.

What's the minimum and maximum voltage the RS485 to RS 232 Converter Card can handle?

Min and Max voltage levels: +7 to +40 VDC

Using a PLC to communicate with board

After the command, you need to issue a carriage return and linefeed.

Example: /1A1000R (absolute position move 1000). After the R, send a 0x0d in hex.

USB Converter card setup

The USB485 converter card requires a driver installed on your computer. The needed driver files can be found by selecting the 'Download' tab, at the following link: <http://www.linengineering.com/accessories/USB485.aspx>

After installation, you should be able to view the converter card if you go to Properties of "My Computer" → Device Manager → Ports.

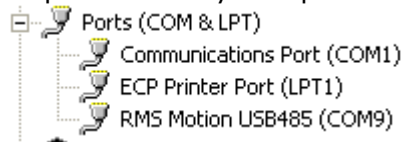

The LED's on the USB485 converter card only light up during sending and receiving of a command.

9. Appendix

Connecting to the old non-RoHS RS232 card

SP17C pin#	SP17C color	RS232 card pin#
4	Black/white	A (RS485A)
3	Brown	B (RS485B)
6	Green	- (GND)
1	Red	+ (PWR)

Table 10



Figure 13

The RS232 card requires power (7-40VDC). Power is then sent to the motor via the Red 4-Pin connector.

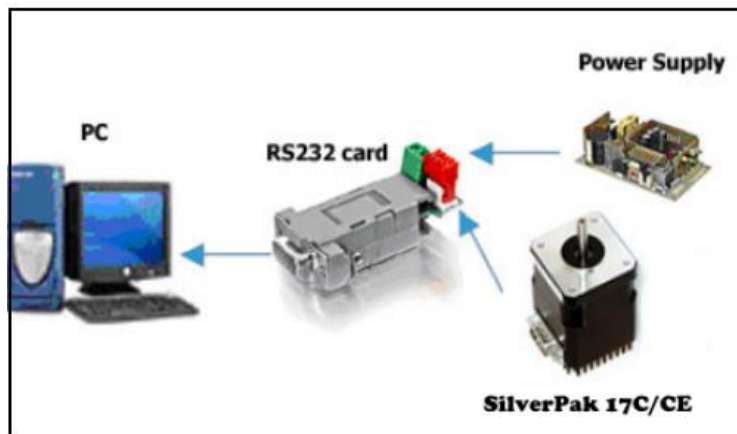

Figure 14: Connection using RS232

5. The RS232 converter card connects to the Silverpak using the DB-9 cable that is provided to you. The red 4-Pin connector is placed onto the converter card.
6. Your power supply will be connected to the RS232 card where the green header is located. **+ is for +12 to +40VDC, - is for the Power Supply Ground.**
7. Connect the RS232 card to your PC with a male to female DB-9 cable.
8. After all connections are completed, turn your power supply on and follow instructions for using LinCommand.

How to connect with old cable:

If you have a cable with a Red 4-Pin connector, simply cut off this connector, strip the wires and reconnect to a 3-Pin connector in the following manner:

Old 4-Pin cable		Connect to	New 3-Pin cable	
Pin #	Color/function		Color/function	Pin #
Pin 1	Red (PWR)	→	Connect to main power supply	--
Pin 2	Green (GND)	→	Green (GND)	Pin 2
Pin 3	Brown RS485 B (+)	→	Brown RS485 B (+)	Pin 3
Pin 4	Black/white RS485 A (-)	→	Black/white RS485 A (-)	Pin 1

Peak current versus Amps/Phase

Where does the 1.4 times come from? Current is continuously changing when a motor steps. If the motor is rated for 1.0 A/Ph, it may receive 0 Amps, 1 Amp, 1.4 Amps, or anything in between if you are microstepping. For ease of explanation, we will look at the current waveform when we half step, or set the driver/controller to 2x microstepping.

If we take a look at both the A and B phases, and plot on an X-Y chart of when each phase receives current, and how much it receives, it will look like the chart below. Beginning at position 1, Phase A receives negative current, and Phase B receives positive current. Let's assume it is at coordinate (-1, 1).

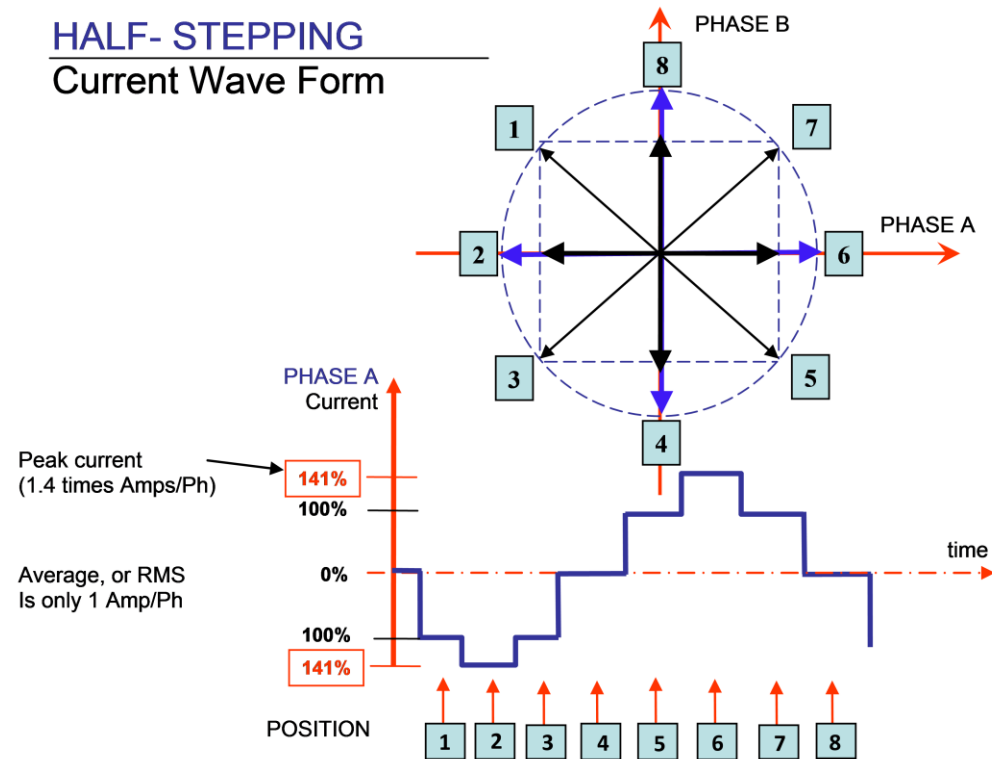

The position versus time graph just above, plots only the A Phase, following the eight different steps the motor will make. Current is changing with each position. Recall that a negative in electronics simply means reverse direction of current flow.

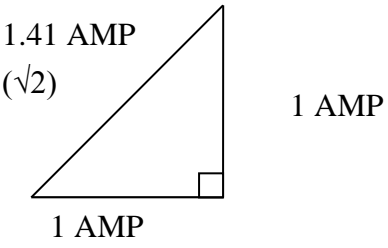
	<p>Take a look at position #7. If we were to draw the arrow at position 7 as the hypotenuse of a triangle, it would look like the triangle to our left. Recall from geometry a 90°-45°-45° triangle is a 1-1-√2 combination. The √2, or 1.4 value is also the radius of the dotted circle shown above. Therefore, during certain steps, Phases A or B will receive 1.4 Amps of current. But the average, or RMS current throughout these 8 steps is only 1.0 Amps. RMS and Amps/Phase is the same meaning.</p>
<p>The 1.4A along this hypotenuse is also known as the 2-Phase On position, since both A and B Phases are "On" and receive current. It is also known as the peak current.</p> <p>As we see the waveform that's plotted for the A Phase, the highest value on the curve is known as the peak value.</p> <p>Motors have a rated current, or average RMS value since in operation, the current is continuously changing. The most logical way to describe a rating is to take an average, or RMS (root means squared) value. But drivers understand current in terms of peak current, therefore the conversion is: Amps/Phase x 1.4 = Amps Peak</p>	

**Technical Support for Lin Engineering
(Mon.-Fri., 8:00 a.m.-5:00 p.m.)**

Our technical support group is glad to work with you in answering your questions. If you cannot find the solution to your particular application, or, if for any reason you need additional technical assistance, please contact our technical support by phone at, **408-919-0200**, email at, techsupport@linengineering.com, on the Web: www.linengineering.com, and **Live Support**

