

AGeneral Description

The LA1117 is a low dropout three terminal regulator that features a low quiescent current, low input, output and dropout voltages, as well as over temperature shutdown. The output voltage of the LA1117 is set at the factory and trimmed to $\pm 1\%$. The LA1117 is stable with a ceramic output capacitor of 4.7 μ F.

This family of regulators can provide either a stand-alone power supply solution or act as a post regulator for switch mode power supplies. They are particularly well suited for applications requiring low input and output voltage.

Features

- Min. 1.1A Output Current Limiter
- 1.4V Maximum Full load Dropout Voltage
- 3-Terminal Adjustable or Fixed , 1.5V, 2.5V, 3.3V and 5V Output Voltage
- Fast Load Transient Response
- Built-in Over Current Protection
- Built-in Over Temperature Protection
- Good Noise Rejection Capability
- Stable with Ceramic Cap of 4.7 μ F
- Package : TO252-2L, SOT89-3L, TO220-3L and SOT223-3L
- RoHS Compliant & Halogen Free

Applications

- PC Mother Board Applications
- LCD TV/ Monitors
- Communication Devices

Please be aware that an Important Notice concerning availability, disclaimers, and use in critical applications of LSC products is at the end of this document.
--

Block Diagram

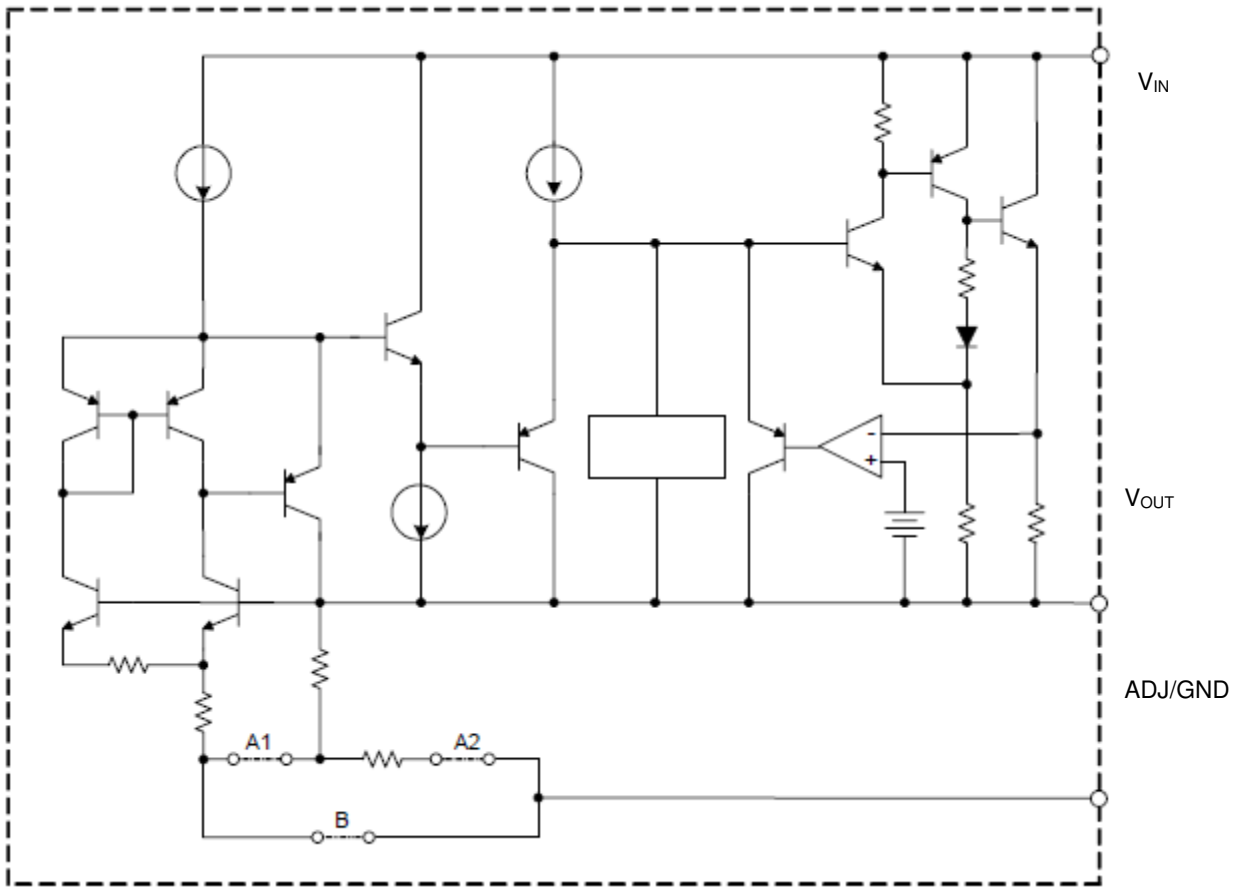
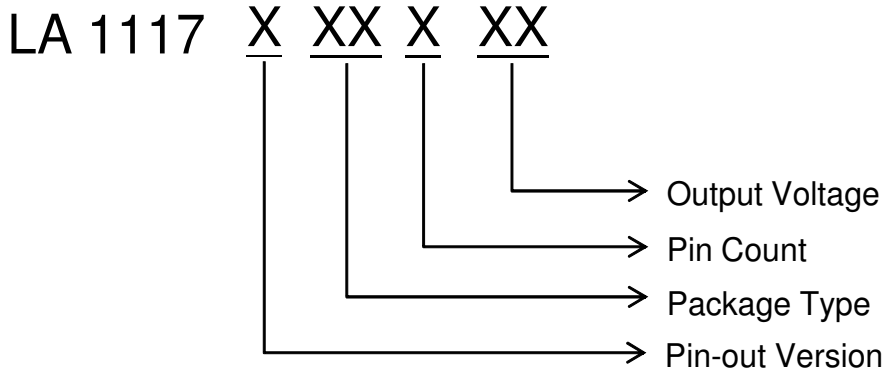

Figure 1 . Block Diagram

Ordering Information



Pin-out Version	Package Type	Pin Count	Output Voltage
<p>A</p> <p>1. ADJ/GND 2. VOUT 3. VIN</p> <p>(TO-252-2L) (SOT89-3L) (SOT220-3L) (SOT223-3L)</p>	<p>AD : SOT223 AT : SOT89 AC : TO252 AQ : TO220</p>	<p>A : 2 B : 3</p>	<p>ADJ : Adjustable 150 : 1.50V 250 : 2.50V 330 : 3.30V 500 : 5.00V</p>
<p>B</p> <p>1. ADJ/GND 2. VIN 3. VOUT</p> <p>(SOT89-3L)</p>			

Pin Assignment

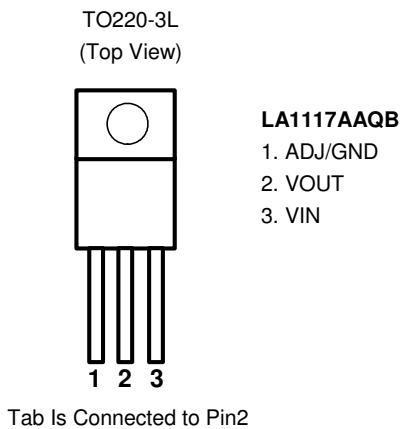
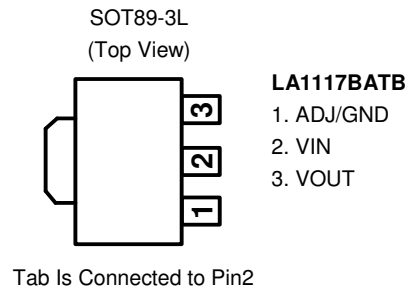
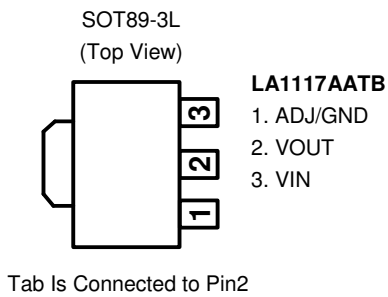
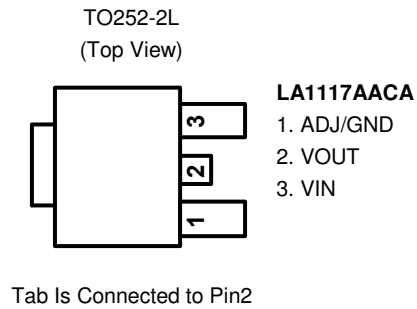
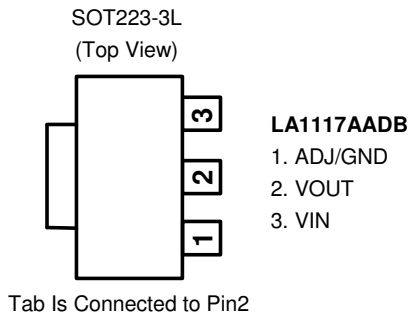

Pin Descriptions

Pin Name	Pin Description
ADJ/GND	Vout Adjusting Pin or Ground Pin
VOUT	Voltage Output
VIN	Voltage Input

Absolute Maximum Ratings (at $T_A=25\text{ }^\circ\text{C}$)

Operate over the “Absolute Maximum Ratings” may cause permanent damage to the device. Exposure to such conditions for extended time may still affect the reliability of the device.

Parameter		Value
DC Supply Voltage		-0.3-18V
Operation Junction Temperature Range (note1)		-40~150 °C
Storage Temperature Range		-65 °C to 150 °C
Lead Temperature		260 °C, to 10 sec
ESD Withstand Voltage: - Human Body Model (HBM), Model = 2 - Machine Model (MM) Model = B		2000V 200V
Thermal Resistance (Junction to Case) (θ_{JC})	SOT223-3L	31 °C/W
	SOT89-3L	46 °C/W
	TO220-3L	15 °C/W
	TO252-2L	30 °C/W
Thermal Resistance (Junction to Ambient) (θ_{JA})	SOT223-3L	125 °C/W
	SOT89-3L	180 °C/W
	TO220-3L	55 °C/W
	TO252-2L	140 °C/W
Power Dissipation	SOT223-3L	800 mW
	SOT89-3L	550 mW
	TO220-3L	1800 mW
	TO252-2L	1000 mW
Moisture Sensitivity		Please Refer The Moisture Sensitivity Label on the IC packing bag material for more detail.

Note 1 : Maximum Junction Temperature is the temperature limit of this device. Over this limit, the IC may be damaged permanently. Operation Junction Temperature Range is the range the device intended to be functional, but specific performance is not guaranteed. For guaranteed specifications and the test conditions, please refer the Electrical Characteristics

Recommended Operating Conditions

Characteristics	Symbol	Min	Max	Unit
Operating Junction Temperature Range	T_J	-40	125 (Note2)	°C

Note 2 : If the IC experienced OTP, then the temperature may need to drop to <125 °C to let the IC recover.

Electrical Characteristics

TA=25°C, C_{IN}=C_{OUT}=4.7µF ceramic capacitance, unless otherwise specified.

Parameter	Symbol	Conditions	Min	Typ	Max	Units
Reference Voltage	V _{REF}	LA1117-ADJ V _{IN} =V _{OUT} + 1.5V, I _{OUT} = 10mA	1.238	1.250	1.262	V
Output Voltage	V _{OUT}	LA1117-1.5V 3V ≤ V _{IN} ≤ 12V, I _{OUT} = 10mA	1.485	1.500	1.515	V
		LA1117-2.5V 4V ≤ V _{IN} ≤ 12V, I _{OUT} = 10mA	2.475	2.500	2.525	
		LA1117-3.3V 4.8V ≤ V _{IN} ≤ 12V, I _{OUT} = 10mA	3.267	3.300	3.333	
		LA1117-5.0V 6.5V ≤ V _{IN} ≤ 12V, I _{OUT} = 10mA	4.950	5.000	5.05	
Line Regulation (=Δ V _{OUT} /Δ V _{IN})	ΔV _{OUT}	LA1117- ADJ/1.5V/2.5V/3.3V/5.0V V _{OUT} +1.5V < V _{IN} < 12V, I _{OUT} = 10mA (Note 3)		0.04	0.2	%
Load Regulation (=Δ V _{OUT})	V _{OUT}	LA1117-ADJ V _{IN} = V _{OUT} +1.5V, 10mA < I _{OUT} < 1A (Note 3)			1	%
		LA1117-1.5V V _{IN} = 3.0V, 10mA < I _{OUT} < 1A (Note 3)		12	15	mV
		LA1117-2.5V V _{IN} = 4.0V, 10mA < I _{OUT} < 1A (Note 3)		20	25	mV
		LA1117-3.3V V _{IN} = 5.0V, 10mA < I _{OUT} < 1A (Note 3)		26	33	mV
		LA1117-5.0V V _{IN} = 8.0V, 10mA < I _{OUT} < 1A (Note 3)		40	50	mV
Dropout Voltage	V _{DO}	LA1117- ADJ/1.5V/2.5V/3.3V/5.0V I _{OUT} = 0.8A, ΔV _{OUT} = V _{OUT} X 1% -40°C ≤ T _J ≤ 125°C		1.2	1.3	V
		LA1117- ADJ/1.5V/2.5V/3.3V/5.0V I _{OUT} = 1.0A, ΔV _{OUT} = V _{OUT} X 1% -40°C ≤ T _J ≤ 125°C		1.3	1.4	
Output Current Limit (Note4)	I _{LIMIT}	LA1117- ADJ/1.5V/2.5V/3.3V/5.0V (V _{IN} -V _{OUT}) = 2V	1100			mA
Minimum Required Load Current	I _{L(min)}	LA1117- ADJ/1.5V/2.5V/3.3V/5.0V -40°C ≤ T _J ≤ 125°C		5	10	mA
Adjust Pin Current	I _{ADJ}	LA1117-ADJ, V _{IN} =V _{OUT} +1.5V, I _{OUT} =10mA		50	120	µA
Adjust Pin Current Change	ΔI _{ADJ}	LA1117-ADJ V _{IN} =V _{OUT} +1.5V to V _{IN} =12V, I _{OUT} =10mA to 800mA		1.5	5	µA

Electrical Characteristics (Contd.)

TA=25°C, C_{IN}=C_{OUT}=4.7µF ceramic capacitance, unless otherwise specified.

Parameter	Symbol	Conditions	Min	Typ	Max	Units
Ripple Rejection (Note 4)	PSRR	V _{IN} =5V, V _{OUT} =1.25V, I _{OUT} =0.01A, 120 Hz sine wave, C _{OUT} =4.7µF ceramic Cap.		70		dB
RMS Output Noise (% of V _{OUT}) (Note 4)	e _N	10Hz ≤ f ≤ 10 kHz		0.003		%
V _{OUT} Temperature Coefficient (Note 4)	TC	TA = 25°C, 30ms Pulse		100		ppm/°C
Thermal Shutdown (Note 4)	T _{SD}			150		°C
Thermal Shutdown Hysteresis	T _{SD(Hys)}			25		°C

Note 3 : Line and load regulation are measured by low duty cycle pulse testing and the junction temperature is kept at 25 degree C. The V_{OUT} of load regulation is measured at the out lead.

Note 4 : Guarantee by design. Not 100% tested in manufacturing.

Application Circuit

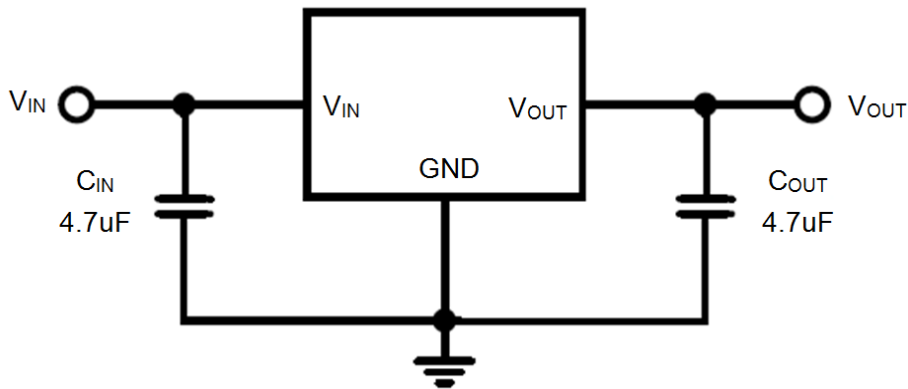

Figure 3(a). Typical Application Circuit – Fixed Output Versions

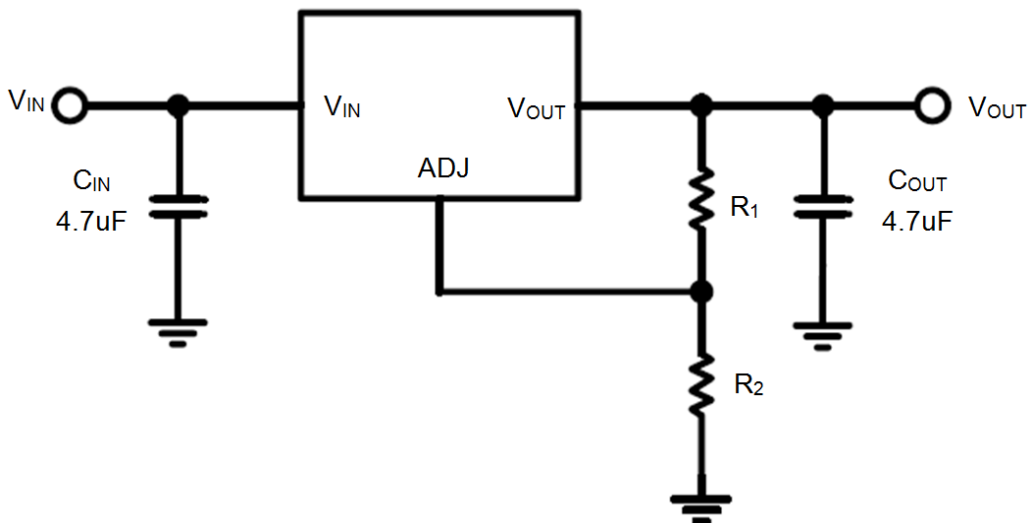
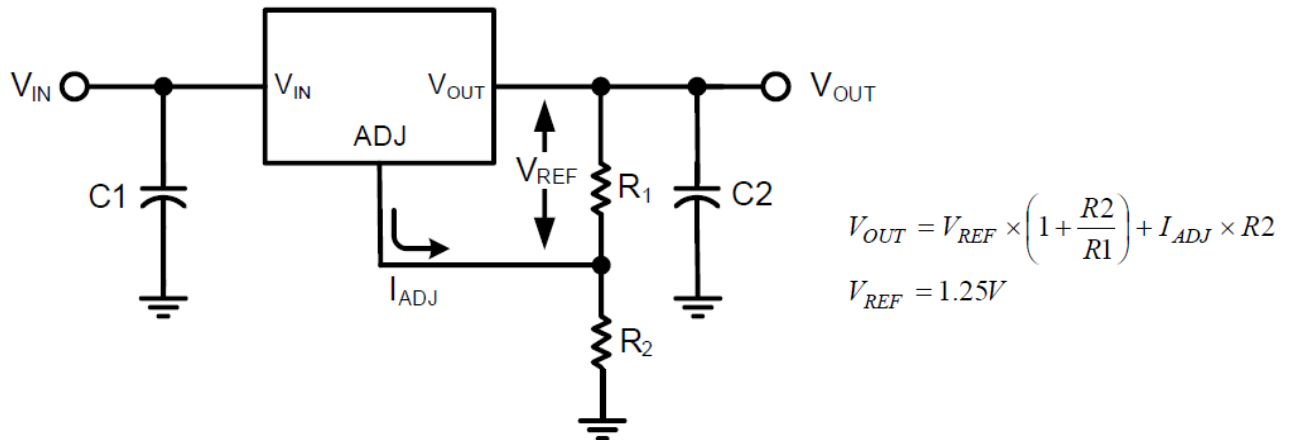

Figure 3(b). Typical Application Circuit – Adjustable Output Version

The LA1117 keeps a constant 1.25V between the output pin and the adjust pin. By placing a resistor R_1 across these two pins a constant current flows through R_1 , adding to the I_{ADJ} current and into the R_2 resistor producing a voltage equal to the $(1.25/R_1) * R_2 + I_{ADJ} * R_2$ which will be added to the 1.25V to set the output voltage.

Application Circuit (Contd.)



This is summarized in the above equation. Since the minimum load current requirement of the LA1117 is 10mA, R₁ is typically selected to be 121Ω resistor so that it automatically satisfies the minimum current requirement. Notice that since I_{ADJ} is typically in the range of 50uA it only adds a small error to the output voltage and should only be considered when a very precise output voltage setting is required. For example, in a typical 3.3V application where R₁=121Ω and R₂=200Ω. The C₁, C₂ capacitor are 4.7uF (Low ESR Ceramic, MLCC).

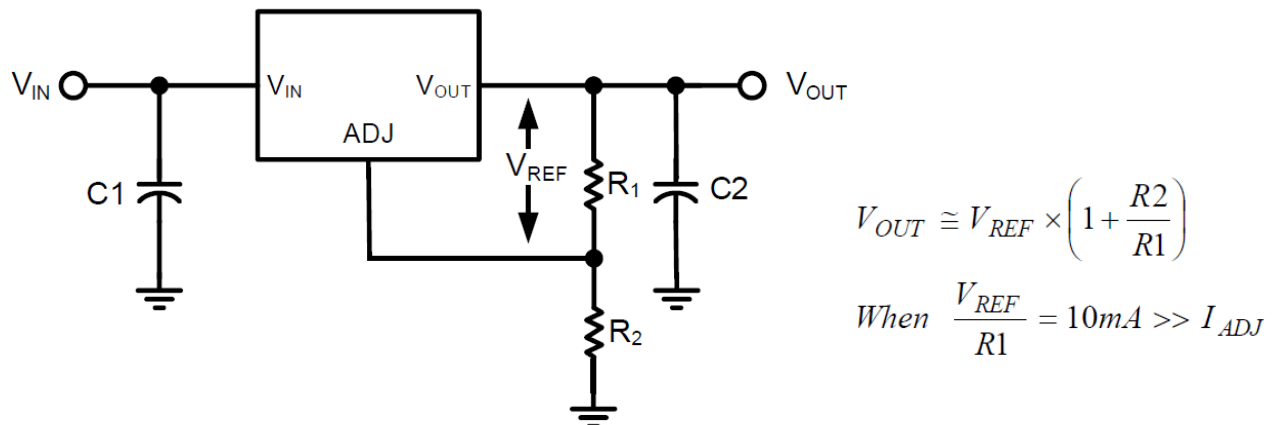

Typical Characteristics

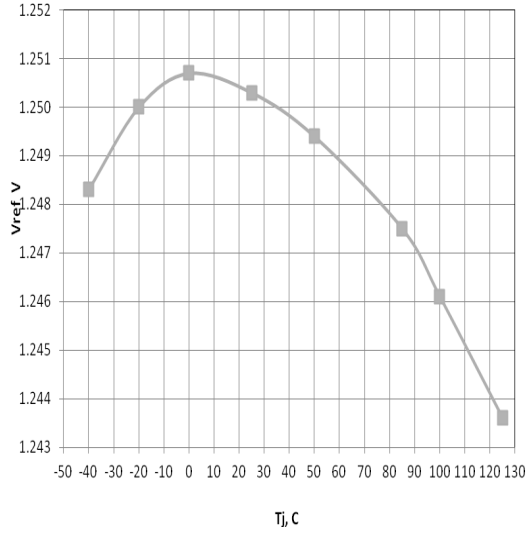

Figure 4. Reference Voltage VS Junction Temperature

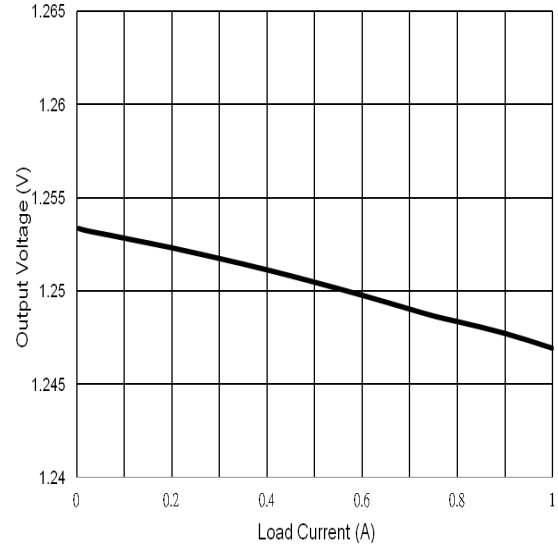

Figure 5. Output Voltage VS Load Current

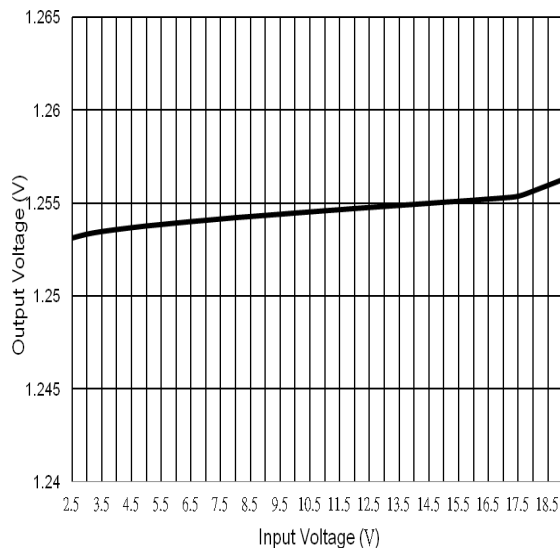

Figure 6. Output Voltage VS Input Voltage

Typical Characteristics (Contd.)

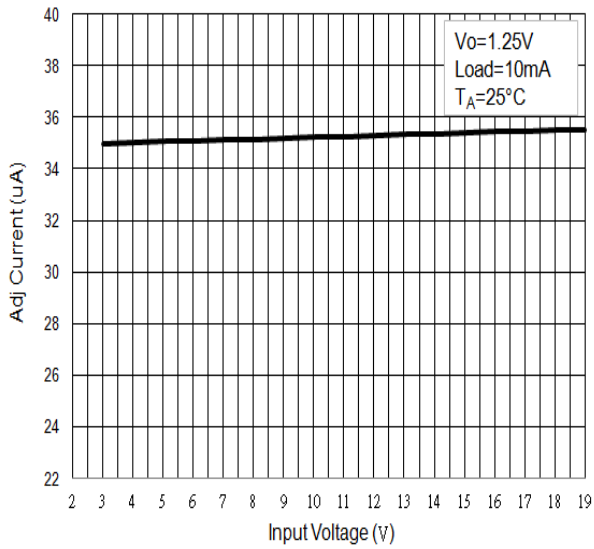

Figure 7. Adj Current VS Input Voltage

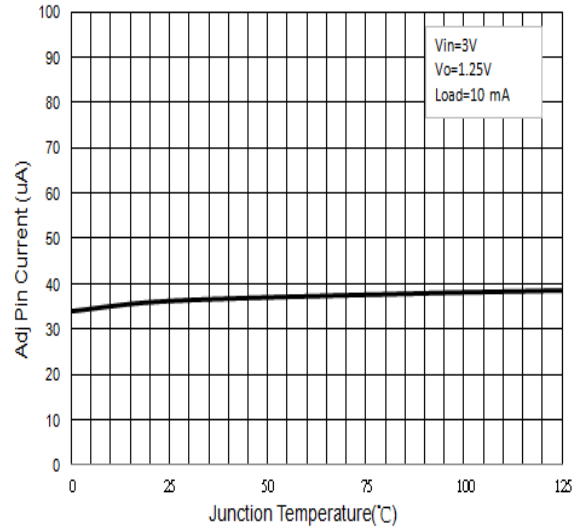

Figure 8. Adj Current VS Junction Temperature

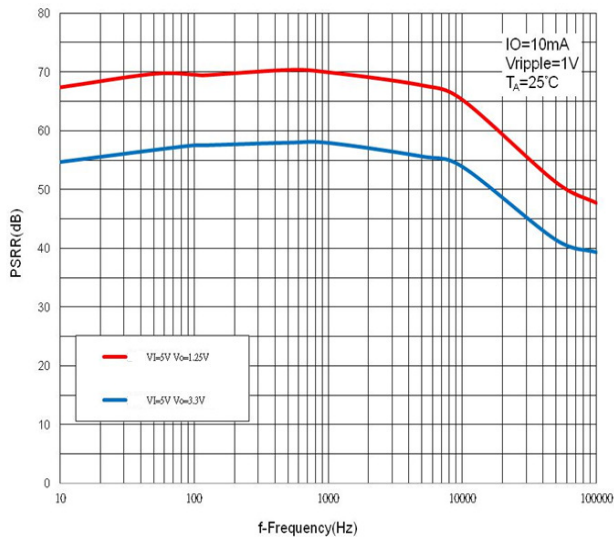

Figure 9. Power Supply Rejection Ratio

Typical Characteristics (Contd.)

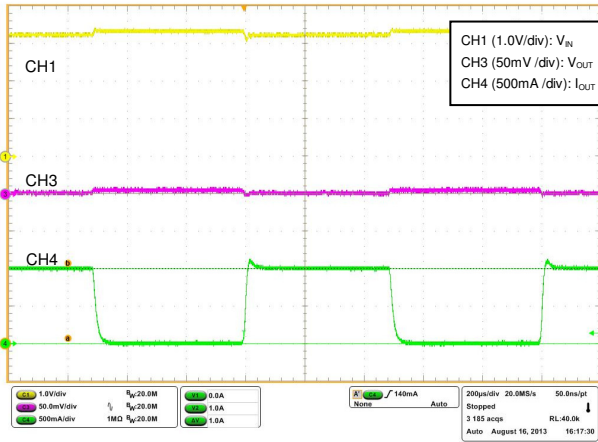

Figure 10. $T_A=25^\circ\text{C}$, $V_{IN}=3.3\text{V}$, $V_{OUT}=1.25\text{V}$, $I_{OUT}=5\text{mA} \sim 1\text{A}$

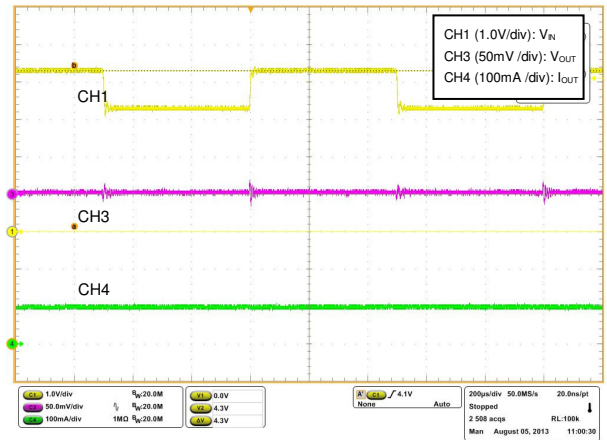
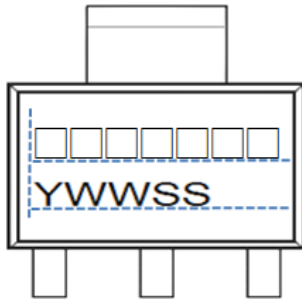

Figure 11. $T_A=25^\circ\text{C}$, $V_{IN}=3.3\sim 4.3\text{V}$, $V_{OUT}=1.25\text{V}$, $I_{OUT}=0.1\text{A}$

Marking Information

(1)SOT223-3L



- 1) □□□□□□ = Marking Name
 A1117B1 = LA1117AADB250
 A1117B2 = LA1117AADBADJ
 A1117B3 = LA1117AADB500
 A1117B4 = LA1117AADB150
 A1117B6 = LA1117AADB330
- 2) YWWSS = Date Code & Internal Code
 Y = Year
 WW = Week
 SS = Internal Code

(2)SOT89-3L

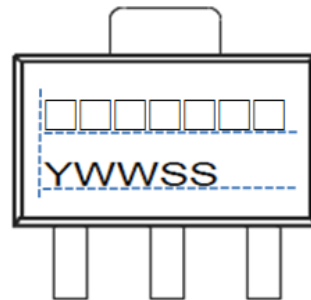

- 1) □□□□□□ = Marking Name
 A1117C = LA1117AATBADJ
 A1117C1 = LA1117AATB330
 A1117C2 = LA1117BATBADJ
 A1117C4 = LA1117AATB250
 A1117C5 = LA1117AATB150
 A1117C6 = LA1117AATB500
- 2) YWWSS = Date Code & Internal Code
 Y = Year
 WW = Week
 SS = Internal Code

(3)TO252-2L

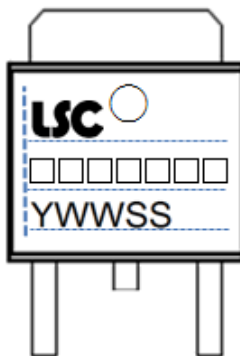

- 1) □□□□□□ = Marking Name
 A1117A1 = LA1117AACAADJ
 A1117A2 = LA1117AACA150
 A1117A4 = LA1117AACA250
 A1117A5 = LA1117AACA330
 A1117A6 = LA1117AACA500
- 2) YWWSS = Date Code & Internal Code
 Y = Year
 WW = Week
 SS = Internal Code

(4)TO220-3L

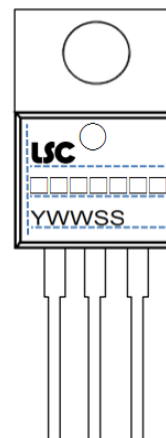

- 1) □□□□□□ = Marking Name
 A1117Q1 = LA1117AAQBADJ
- 2) YWWSS = Date Code & Internal Code
 Y = Year
 WW = Week
 SS = Internal Code

Mechanical Information

(1) Package type: SOT223-3L

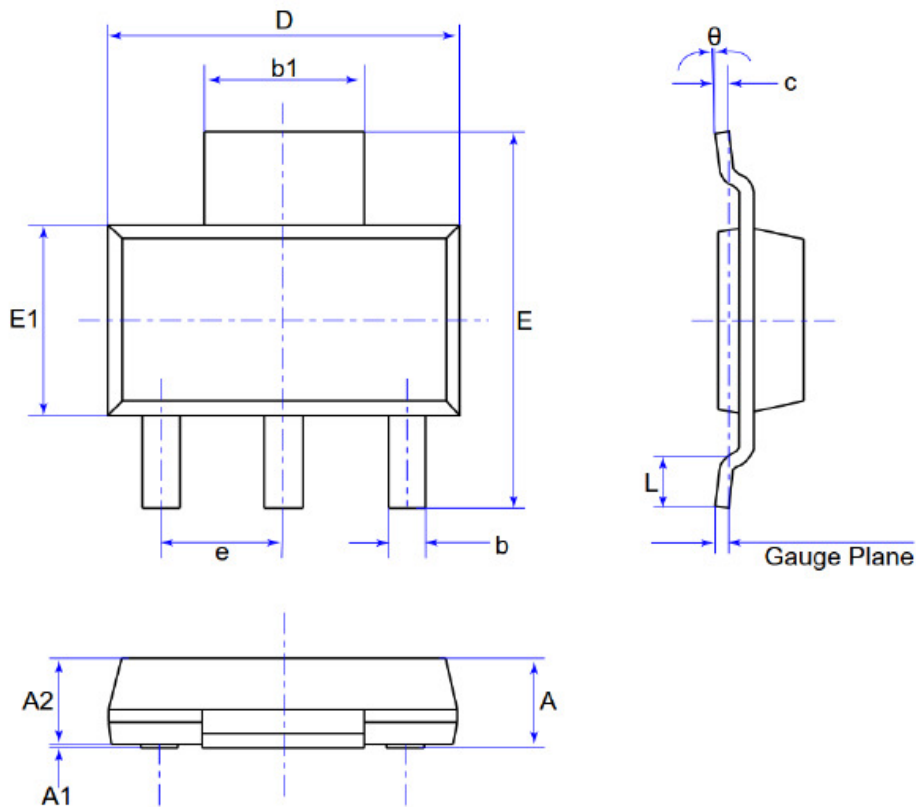

Unit: mm

Symbol	Min	Max
A	-	1.80
A1	-	0.10
A2	1.45	1.75
b	0.66	0.84
c	0.23	0.35
D	6.20	6.70
b1	3.00 REF	
E	6.70	7.30
E1	3.30	3.70
e	2.30 BSC	
L	0.75	-
θ	0°	10°
Gauge Plane	0.30 REF	

Mechanical Information (Contd.)

(2) Package type: SOT89-3L

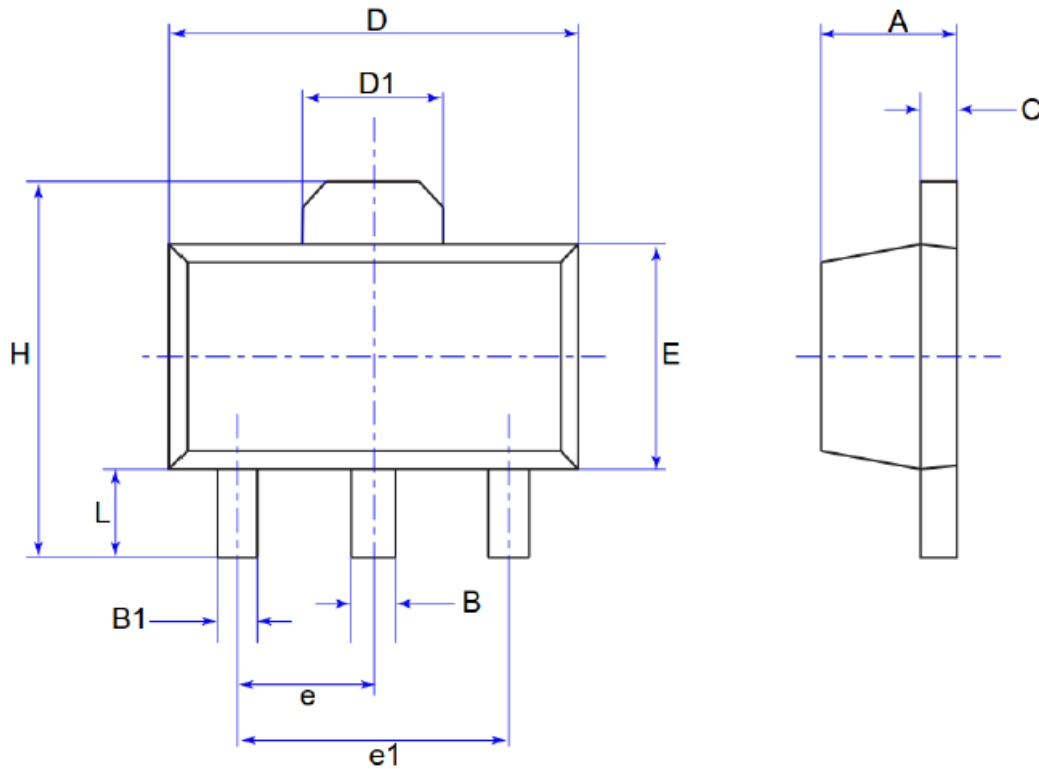

Unit: mm

Symbol	Min	Max
A	1.40	1.60
B	0.35	0.58
B1	0.32	0.58
C	0.35	0.46
D	4.30	4.70
D1	1.60 REF	
E	2.30	2.70
e	1.50 TYP	
e1	3.00 TYP	
H	3.94	4.70
L	0.80	1.20

Mechanical Information (Contd.)

(3) Package type: TO252-2L

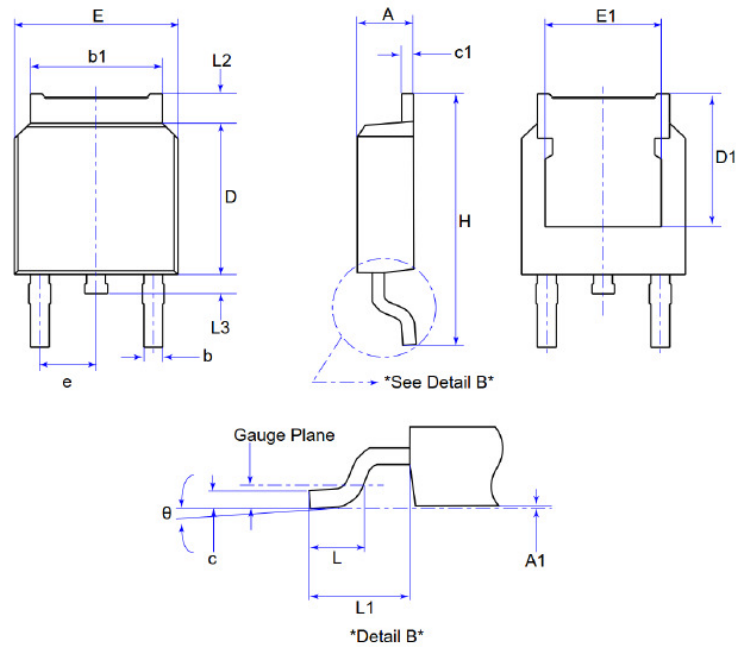

Unit: mm

Symbol	Min	Max
A	2.200	2.400
A1	-	0.127
b	0.660	0.860
b1	5.334 REF	
c	0.460	0.600
c1	0.460	0.580
D	6.000	6.200
D1	5.300 REF	
E	6.500	6.700
E1	4.830 REF	
e	2.186	2.400
H	9.80	10.400
L	1.400	1.700
L1	2.900 REF	
Gauge plane	0.508REF	
L2	0.900	1.300
L3	0.600	1.000
θ	0°	8°

Mechanical Information (Contd.)

(4) Package type: TO220-2L & 3L

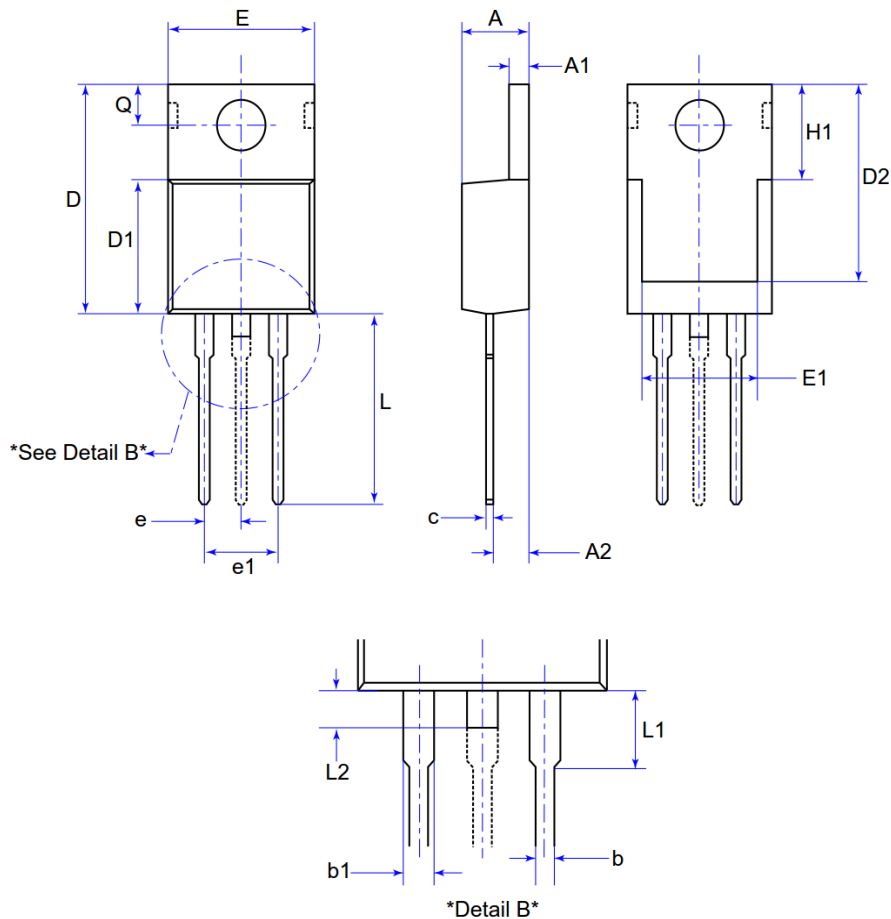

Unit: mm

Symbol	Min	Max
A	4.400	4.670
A1	1.200	1.400
A2	2.230	2.720
b	0.700	0.910
b1	1.170	1.550
c	0.330	0.650
D	14.840	15.950
D1	8.600	9.750

Symbol	Min	Max
E	9.850	10.260
E1	6.858	8.890
e	2.540 REF	
e1	5.080 REF	
H1	5.842	6.858
L	12.700	13.760
L1	-	3.710
L2	-	1.778
Q	2.650	2.950

MSL (Moisture Sensitive Level) Information

IPC/JEDEC J-STD-020D.1 Moisture Sensitivity Levels Table

LEVEL	FLOOR LIFE		SOAK REQUIREMENTS				
			Standard		Accelerated Equivalent ¹		
	TIME	CONDITION			TIME (hours)	CONDITION	eV 0.40-0.48
			TIME (hours)	TIME (hours)			
1	Unlimited	≤30 °C /85% RH	168 +5/-0	85 °C /85% RH	NA	NA	NA
2	1 year	≤30 °C /60% RH	168 +5/-0	85 °C /60% RH	NA	NA	NA
2a	4 weeks	≤30 °C /60% RH	696 ² +5/-0	30 °C /60% RH	120 -1/+0	168 -1/+0	60 °C/ 60% RH
3	168 hours	≤30 °C /60% RH	192 ² +5/-0	30 °C /60% RH	40 -1/+0	52 -1/+0	60 °C/ 60% RH
4	72 hours	≤30 °C /60% RH	96 ² +2/-0	30 °C /60% RH	20 +0.5/-0	24 +0.5/-0	60 °C/ 60% RH
5	48 hours	≤30 °C /60% RH	72 ² +2/-0	30 °C /60% RH	15 +0.5/-0	20 +0.5/-0	60 °C/ 60% RH
a	24 hours	≤30 °C /60% RH	48 ² +2/-0	30 °C /60% RH	10 +0.5/-0	13 +0.5/-0	60 °C/ 60% RH
6	Time on Label (TOL)	≤30 °C /60% RH	TOL	30 °C /60% RH	NA	NA	NA

Note 1: CAUTION - To use the “accelerated equivalent” soak conditions, correlation of damage response (including electrical, after soak and reflow), should be established with the “standard” soak conditions. Alternatively, if the known activation energy for moisture diffusion of the package materials is in the range of 0.40 - 0.48 eV or 0.30 - 0.39 eV, the “accelerated equivalent” may be used. Accelerated soak times may vary due to material properties (e.g .mold compound, encapsulant, etc.). JEDEC document JESD22-A120 provides a method for determining the diffusion coefficient.

Note 2: The standard soak time includes a default value of 24 hours for semiconductor manufacturer’s exposure time (MET) between bake and bag and includes the maximum time allowed out of the bag at the distributor’s facility. If the actual MET is less than 24 hours the soak time may be reduced. For soak conditions of 30 °C/60% RH, the soak time is reduced by 1 hour for each hour the MET is less than 24 hours. For soak conditions of 60 °C/60% RH, the soak time is reduced by 1 hour for each 5 hours the MET is less than 24 hours. If the actual MET is greater than 24 hours the soak time must be increased. If soak conditions are 30 °C/60% RH, the soak time is increased 1 hour for each hour that the actual MET exceeds 24 hours. If soak conditions are 60 °C/60% RH, the soak time is increased 1 hour for each 5 hours that the actual MET exceeds 24 hours.

Important Notice and Disclaimer

LSC reserves the right to make changes to this document and its products and specifications at any time without notice. Customers should obtain and confirm the latest product information and specifications before final design, purchase or use.

LSC makes no warranty, representation or guarantee regarding the suitability of its products for any particular purpose, nor does LSC assume any liability for application assistance or customer product design. LSC does not warrant or accept any liability with products which are purchased or used for any unintended or unauthorized application.

No license is granted by implication or otherwise under any intellectual property rights of LSC.

LSC products are not authorized for use as critical components in life support devices or systems without express written approval of LSC.