

1. This specification is applied to following Safety Standard Recognized Ceramic Capacitor for Electronics Appliance.

VDE /FIMKO/DEMKO/NEMKO/SEMKO/SEV
X1,Y2 Class(en132400)based on IEC 384-14 2nd Edition
UL/CSA /CQC

2.Approval Standard and Recognized

	Standard No	Recognized No.	AC Rated Voltage V(r.m.s.)
UL	UL 1414		250
CSA	C22.2 No.1		
VDE	IEC60384-14 (ed2);am1 (EN 132400)		X1:400 Y1:400
FIMKO			
DEMKO			
SEMKO			
NEMKO			
SEV			
CQC			

3.Part numbering

Ex: JB Y5P 101P K Y P9.5 D5 L25
Type Temperature Capacitance Capacitance Tolerance Lead Style Lead Spacing Nminal Body Lead Length
P7.5.:7.5mm Diameter L25:25±1mm
P9.5:9.5mm

4.Rating

4.1 Operating Temperature: -25~+85°C

4.2 Lead Style :

Lead code : Y

Lead code :K

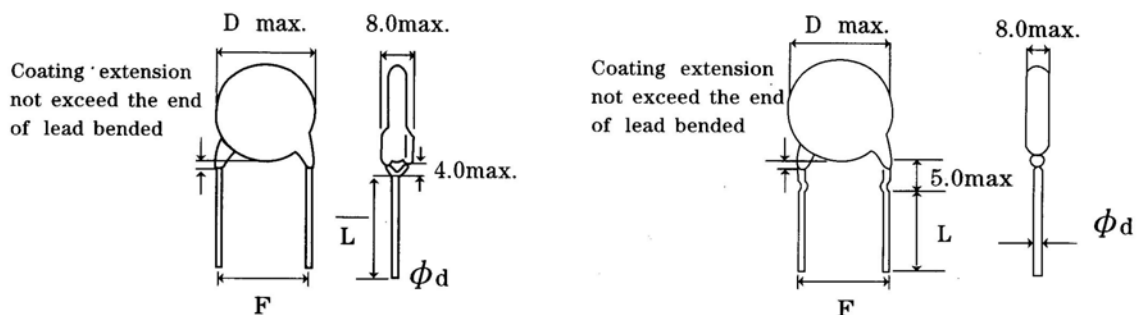

核准	審查	編制	發行日期	文件版本

2/8	交流安規圓板陶瓷電容器承認書 X1 , Y1	文件編號
-----	------------------------	------

Marking:

FIMKO APPROVAL MARK:  Typesignae Dtion:JB

VDE Approval Mark:  Nominal Capacirance:3-digit-susem

NEMKO Approval Mark:  Capacirance Tolerance: Code

DEMKO Approval Mark:  Company Name Code: JHC

SEMKO Approval Mark:  Manufactured Date: Abbreviation

SEV Approval Mark: 

CSAAprovalMark:

UL Approval Mark:



2005 年

Ex: 5

1

1: First Quarter

2 :Secondly Quarter

3: Third Quarter

4: Four Quarter

CQC Approval Mark:



IEC 60384-14 CLASS CODE:X1,Y1

IEC 60384-14CLASS: 400~X1

RATED VOLTAGE MARX 400~Y1

(ex:)

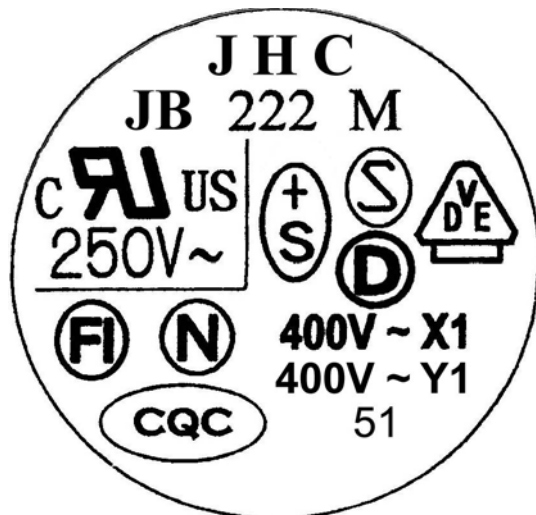

核准	審查	編制	發行日期	文件版本

頁次	交流安規圓板陶瓷電容器承認書 X1,Y1	文件編號
3/8		

Part Numbering								
• Straight long								
Part number	T. C.	Cap (pF)	Cap Tol (%)	Dimensions (unit:mm)				AC tested Vol. V(r. m. s.)
				D Max.	F ±1.0	T Max.	Φd	
MY5P101PKJBP9.5D5	B (Y5P)	100	±10%	7	9.5	8.0	0.65 ±0.05	4500
MY5P151PKJBP9.5D5		150						
MY5P181PKJBP9.5D5		180						
MY5P221PKJBP9.5D5		220		8				
MY5P331PKJBP9.5D6		330						
MY5P471PKJBP9.5D7		470		10				
MY5P681PKJBP9.5D8		680		12				
MY5P102PKJBP9.5D10		1000						
MY5U102PMJBP9.5D7	E (Y5U)	1000	±20%	10	9.5	8.0	0.65 ±0.05	4500
MY5U152PMJBP9.5D9		1500		11				
MY5U222PMJBP9.5D10		2200		13				
MY5U332PMJBP9.5D13		3300		16				
MY5U472PMJBP9.5D15		4700		19				
MY5V102PMJBP9.5D5	F (Y5V)	1000	±20%	8	9.5	8.0	0.65 ±0.05	4500
MY5V152PMJBP9.5D5		1500		9				
MY5V222PMJBP9.5D8		2200		10				
MY5V332PMJBP9.5D10		3300		12				
MY5V472PMJBP9.5D11		4700		13				
MY5V103PMJBP9.5D15		10000		19				
核准	審查	編制	發行日期	文件版本				

Item		Specification	Testing Method
1	Dielectr Strength Between Lead wires	No failure	The capacitors shall not be damage when AC2600V are applied between the lead wires for 60 sec.. (charge/discharge current<50mA)
	Body insulation	No failure	First.the terminals of the capacitor shall be connected Together.Then.a metal foil shall be closely wralled Around the boy of thecapacitor distance of about 3 to 4mm from each terminal.Then.The capacitor shall be inserted into acontainer filled with metal balls of about 1mm diameter.FinallyAC4500V is applied for 60 sec.between the capacitor lead wires and metal balls.(charge/discharge current<50mA)
2	Insulation Resistance(I.R.)	10000M Ω min	The insulation resistanceshall be measured with 500 ±50VDC with 60± 5sec.of charging
3	Capacitance	Within specifid Tolerance.	The Capacitance shall be measured at 20 °C With 1± 0.1kHz and 5Vrms max
4	Dissipation Factor(D.F.)	Char.	The Capacitance shall be measured at 20°C With 1 ±0.1kHz and 5Vrms max
B		Specified	
F		D.F≤2.5%	
5	Temperature Characteristic	Char.	The Capacitance measurement shall be made at Each step specified in Table 1. <Table>
B		Capacitance Change	
F		Within± 10%	
		F	Within-80~+30%
6	Robustness Of Termination	Lead wire shall not cat off capacitor shall not be broken	With the termination n its normal position. The specimen is held buits bodu in such a manner that the zxis of the. temination is vertical the tensile force of 10N shall be applied to the termination in the direction of its axis and acting in a direction awau from the body of the specimen
	Bending	Lead wire shall not cut off Capacitor shall not be broken.	With the termination in its normal position .the specimen is held b its body In such a manner that the axis of the termination is vertical: mass applying a force of 5N is then suspended from the end of the termination. The body of the specimen is then inclined within a period of 2 to 3 sec. ,through an angle of a approximately 90in the vertical plane and then returnrd its initial; position over the same period of time ;this operation constitutes one bend .One bend immediately followed by a second bend in the opposite direction.

※"room condition"temperature:15~35℃, humidity:45~75%,atmospheric pressure 86~106kpa.

核准	審查	編制	發行日期	文件版本

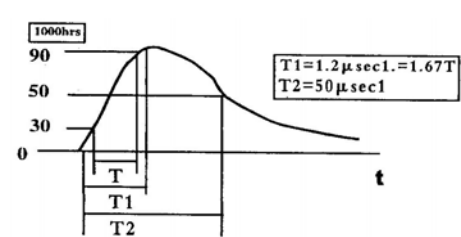
Item	Specification	Testing Method
7	Appearance	Solder temperature: $350 \pm 10^{\circ}\text{C}$ (or $260. \pm 5^{\circ}\text{C}$) Immersion time: $3.5 \pm 0.5\text{sec}$. (In case of $260. \pm 5^{\circ}\text{C}$; $10 \pm 1\text{ sec}$) The depth of immersion shall be a position $2+0/0.5\text{mm}$ from the seating plane. Using a thermal insulating screen of $1.5 \pm 0.5\text{mm}$ thickness. Pre-treatment: Capacitor shall be stored at $85 \pm 2^{\circ}\text{C}$ for 1 hour. then placed at room condition(*) for 24 ± 2 hours before initial measurements. Post-treatment: Capacitor shall be stored for 1 to 2 hours at room condition.
	I.R.	
	Dielectric strength	
	Capacitance	
8	Appearance	Set the capacitor for 500 ± 12 hours at $40 \pm 2^{\circ}\text{C}$, in 90 to 95% humidity. Then Capacitor shall be stored for 1 to 2 hours at room condition.
	Capacitance	
	D.F.	
	I.R.	
	Dielectric strength	
9	Appearance	Apply the rated voltage for 500 ± 12 hours at $40 \pm 2^{\circ}\text{C}$, in 90 to 95% humidity and set it for 1 to 2 hours at room condition.
	Capacitance	
	D.F.	
	I.R.	
	Dielectric strength	
10	Appearance	Impulse Voltage Each individual capacitor shall be subjected to a 5kV impulses for these times. After the capacitors are applied to life test. Fig. 
	Capacitance	
	I.R.	
	Dielectric strength	
	Discharge Test(II)	
The specimen capacitors are placed in a circulating air oven for a period of 1000 hours. Then air in the oven is maintained at a temperature of $125 \pm 2^{\circ}\text{C}$. Throughout the test. The capacitors are subjected to a 425Vrms alternating the voltage is increased to 1000Vrms for 0.1 sec		

※”room condition”temperature: $15 \sim 35^{\circ}\text{C}$, humidity: $45 \sim 75\%$, atmospheric pressure $86 \sim 106\text{kpa}$.

核准	審查	編制	發行日期	文件版本

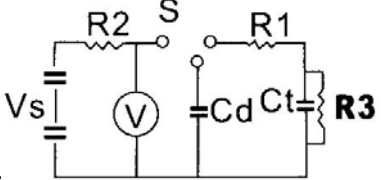
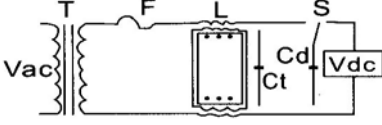
Item	Specification	Testing Method													
11	<table border="1" style="width:100%; border-collapse: collapse;"> <tr> <td style="width:20%;">Discharge Test(I)</td> <td style="width:20%;">Appearance</td> <td style="width:20%;">No marked defect</td> </tr> <tr> <td></td> <td>I.R.</td> <td>1000MΩ min</td> </tr> <tr> <td></td> <td>Dielectric strength</td> <td>Per Item 1</td> </tr> </table>	Discharge Test(I)	Appearance	No marked defect		I.R.	1000MΩ min		Dielectric strength	Per Item 1	<p>As in Figure 1. discharge is made 50 times at 5 sec. Intervals form the capacitor(Cd) charged at DC voltage of specified.</p> <div style="text-align: center;">  </div> <p>Ct: Capacitor under tes S1: High-voltage switch R1: 1000 R2: 100 MΩ R3: Surge resistance</p> <table border="1" style="margin-left: auto; margin-right: auto;"> <tr> <td>Cd</td> <td>0.001μF</td> </tr> <tr> <td>Vs</td> <td>10KVDC</td> </tr> </table>	Cd	0.001μF	Vs	10KVDC
Discharge Test(I)	Appearance	No marked defect													
	I.R.	1000MΩ min													
	Dielectric strength	Per Item 1													
Cd	0.001μF														
Vs	10KVDC														
12	<table border="1" style="width:100%; border-collapse: collapse;"> <tr> <td style="width:20%;">Discharge Test(II)</td> <td style="width:20%;">The cheese-cloth around capacitors shall not glow of flame</td> </tr> </table>	Discharge Test(II)	The cheese-cloth around capacitors shall not glow of flame	<p>A single layer of cheesecloth is to be placed around the body of the test capacitor. Each sample is to be subjected to four discharges form a dump capacitor charged to a voltage that when discharged placed DC5KV across the capacitor under test. The interval between successive discharges is to be 5 sec. AC240V,60Hz potential is to be applied across the capacitor under test and is to be maintained for 30 sec. after the fourth discharge. Unless the circuit is opined in a shorter time bv breakdown of the test capacitor.</p> <p>The direct current supply is to be adjusted to provide a potential in accordance with the following.</p> $V_{dc} = \frac{5000(C_d - C_t)}{C_d} \text{ (V)}$ <div style="text-align: center;">  </div> <p>(Figure 2)</p> <p>Vde: Variable derect-current voltage source S1: High-voltage switch L: Choke coil of approximately 3mH and 0.03Ω F: Plug fuse rated 30A and 250V Vac: Supply source rated 240V,60Hz and 30A Ct: Capacitor under test Cd: Dump capacitor Capacitance value and D.F. ars as follows.</p> <table border="1" style="margin-left: auto; margin-right: auto;"> <tr> <td>Cap. Value of Ct</td> <td>0-0.005μF</td> <td>0.0051-0.05μF</td> </tr> <tr> <td>Cap. Value of Cd</td> <td>0.005μF</td> <td>0.05μF</td> </tr> <tr> <td>D.F. of Cd</td> <td>0.5%max.</td> <td>0.5%amx</td> </tr> </table>	Cap. Value of Ct	0-0.005μF	0.0051-0.05μF	Cap. Value of Cd	0.005μF	0.05μF	D.F. of Cd	0.5%max.	0.5%amx		
Discharge Test(II)	The cheese-cloth around capacitors shall not glow of flame														
Cap. Value of Ct	0-0.005μF	0.0051-0.05μF													
Cap. Value of Cd	0.005μF	0.05μF													
D.F. of Cd	0.5%max.	0.5%amx													
核准	審查	編制	發行日期	文件版本											

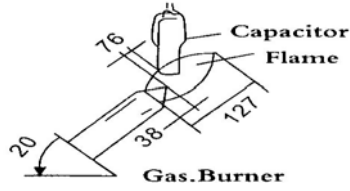
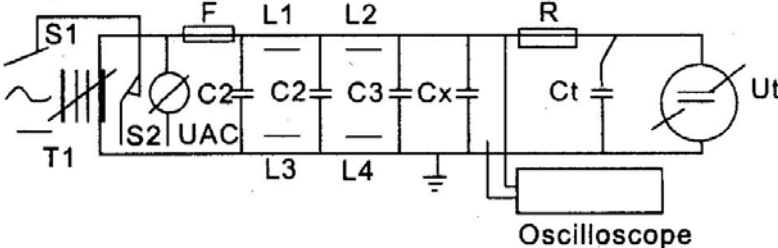
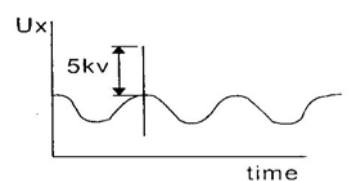
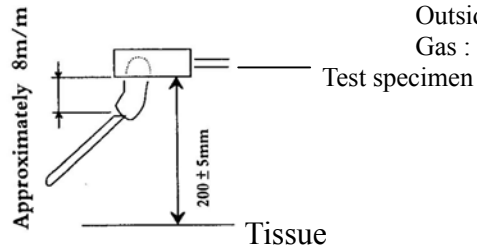
Item	Specification	Testing Method						
13	Flame Test The capacitor flame discontinue as follows <table border="1" style="margin: 10px auto; border-collapse: collapse;"> <tr> <th style="width: 20%;">Cycle</th> <th style="width: 80%;">Time</th> </tr> <tr> <td style="text-align: center;">1-4</td> <td style="text-align: center;">30 sec.max</td> </tr> <tr> <td style="text-align: center;">5</td> <td style="text-align: center;">60 sec.max</td> </tr> </table>	Cycle	Time	1-4	30 sec.max	5	60 sec.max	The capacitor shall be subjected to applied for 15 sec. And them removed for 15 sec, until 5 cycle Fig.  <p style="text-align: right;">(Unit: mm)</p>
Cycle	Time							
1-4	30 sec.max							
5	60 sec.max							
14	Active Flammability The cheese-cloth shall not be on fire	The specimens shall be individually wrapped in at least One but more than two complete layers of cheese-cloth The specimens shall be subjected to 20 discharges. The interval between successive discharges shall be 5sec. The Uac shall be maintained for 2 min. after the last discharge. Fig.  <p style="margin-left: 40px;"> R: 100Ω±2%, Uac: Ur±5% Cx:capacitor Ut: Voltage applied to Ct </p> <p style="margin-left: 40px;"> Ct: 3μF±5% 10KV Ur:Rated working voltage F: Fuse, Rated 10A </p> 						
15	Passive Flammability The burning time shall not be exceeded the time 30 sec. The tissue paper shall not ignite.	The capacitor under test shall be held in the flame in the position, which best promotes burning. Each specimen shall only be exposed once to the flame. Time of exposure to flame: 30 sec. Length of flame: 12±1mm Gas burner: Length 35mm min Inside Dia: 0.5±0.1mm Outside Dia: 0.9mm max. Gas : Butane gas Purity 95%min  <p style="text-align: right;">(Unit: mm)</p>						
核准	審查	編制						
		發行日期						
		文件版本						

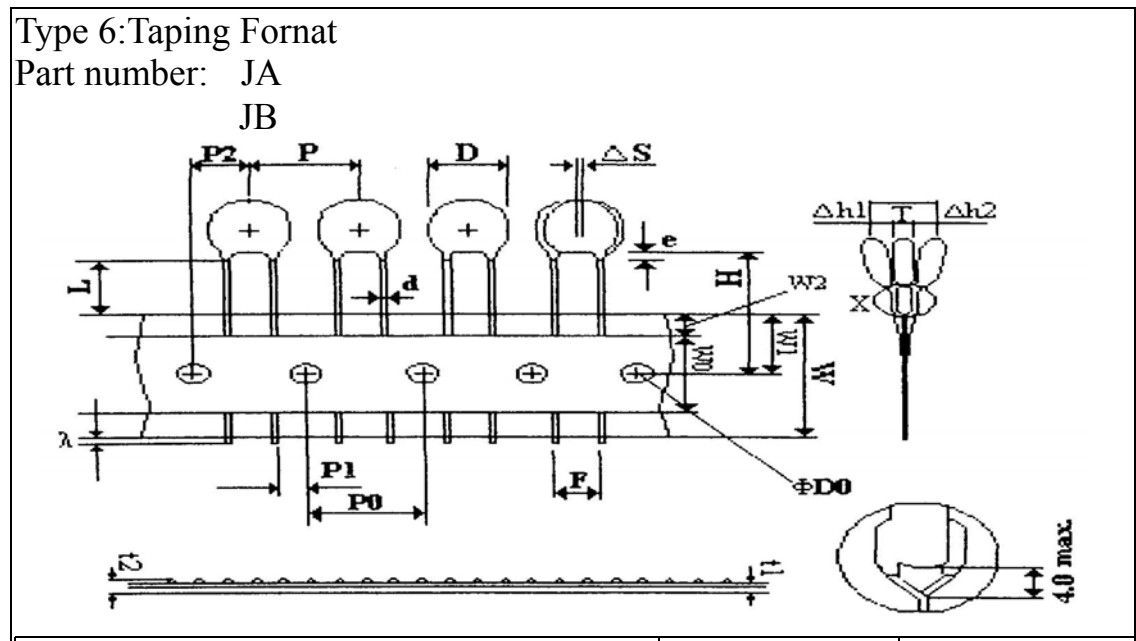

POE P/N		JA	JB	
Item	Symbol	Dimensions(mm)	Dimendions(mm)	
Pitch of comoonent	P	15	30	
Pitch of sprocket	P0	15.0 \pm 0.3	15.0 \pm 0.3	
Lead apacing	F	7.5 \pm 1.0	10.0 \pm 1.0	
Length fron hole center to component center	P2	7.5 \pm 1.5	7.5 \pm 1.5	
Length from hole center to lead	P1	3.75 \pm 1.0	3.75 \pm 1.0	
Body diameter	D	See the individuslproduct specification		
Deviation along taoe,life or right	Δ S	0 \pm 2.0	0 \pm 2.0	
Carrier tape width	W	18.0 \pm 0.5	18.0 \pm 0.5	
Position of sprocket hole	W1	9.0 \pm 0.5	9.0 \pm 0.5	
Lead distance between reference and bottom planes	H	20.0 \pm 1.5	20.0 \pm 1.5	
Protrusion length		+0.5 \sim -1.0	+0.5 \sim -1.0	
Diameter of sprocket hole	D0	4.0 \pm 0.1	4.0 \pm 0.1	
Lead dianeter	d	0.65	0.65	
Total tape thickness	t1	0.6 \pm 0.3	0.6 \pm 0.3	
Total thickness.taoe and lead wire	t2	1.5max.	1.5max.	
Deviation across tape	Δ h1	2.0max	2.0max.	
	Δ h2			
Porion to cut in case of defect	L	11.0 \pm 0.1/-0	11.0 \pm 0.1/-0	
Hole-down tape wisth	W0	11.0	11.0	
Hole-down tape distortion	W2	3.0max	3.0max.	
Coating extension on leads	e	3.0max	3.0max.	
Body thickness	T	See the individual product specification		
核准	審査	编制	發行日期	文件版本