

M21123

DEVICE OVERVIEW

3.2Gbps 24 Port Reconfigurable Non-Blocking Crosspoint Switch

The M21123 is a very low power, reconfigurable, 24 port, non-blocking digital crosspoint switch. The device is optimized for power and performance for data frequencies of up to 3.2Gbps, including Serial Digital Interface (SDI) video data rates.

The M21123 is designed to provide the designer with the utmost choice and flexibility. With 18 reconfigurable input/output ports and 6 dedicated output ports, it may be used to create any square and non-square matrix size, from 18x6, to 12x12, to 1x23 and every size in between.

The M21123 includes signal conditioning to compensate for losses accumulated across long board traces, making it ideal for high speed backplane switching applications. Each input/output port features individually programmable trace equalization when configured as an input, and individually programmable de-emphasis and output swing, when configured as an output. The dedicated output ports have individually programmable de-emphasis and swing control.

For lowest power consumption and ease of heat dissipation management, the device may be powered from a single 1.2V supply. For ease of design and when DC coupling to a voltage other than 1.2V is desired, the high speed input and output ports, as well as the digital interface, may be powered from a 1.2V, 1.8V, 2.5V or 3.3V supply. Furthermore, the input/output ports include on-chip 50Ω termination and are electrically isolated from one another, allowing each to be powered from and terminated to a different voltage rail. This provides additional flexibility as each port on the device may be DC coupled to up-stream and down-stream devices with different voltage rails. The M21123 is offered in a green and RoHS compliant 88-pin QFN package.



> The M21123 is Ideal For

- Signal switching
- Fanout buffers
- Backplane equalizing and re-driving
- 3G/HD/SD-SDI switchers and routers

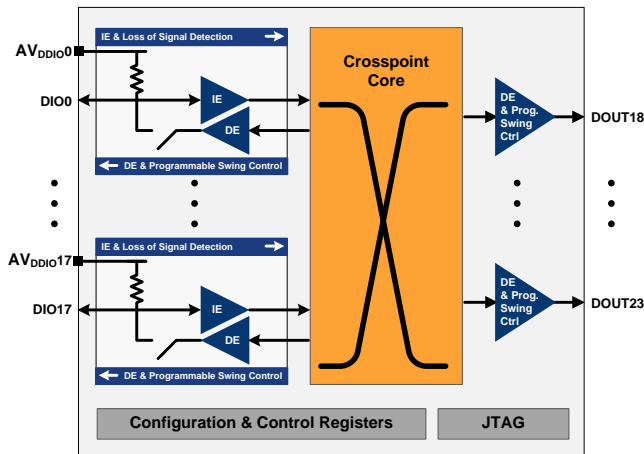

M21123 Block Diagram

Features	Benefits
6 fixed outputs and 18 reconfigurable IOs	Customized square and non-square matrix size
Per port individually programmable input equalization and output de-emphasis	Compensate for signal losses across various trace lengths
Per port individually programmable output swing control	Optimized power consumption and performance for each application
Per port individual powerdown control	Optimized power consumption for variety of applications
Very low power operation (65 mW per channel @1.2V)	Ease of thermal management and reduced cost of operation
DC and AC coupling at the input and output with integrated level shifter	Design and layout flexibility
Integrated 50Ω input and output termination	Ease of design and layout and improved signal integrity
Loss of Signal detection at the input	Diagnostic and debug feature
Standard 2-wire and 4-wire serial digital interface	Flexible control and configuration
Industrial Operation Temperature range of -40°C to 85°C	Robust Operation under a wide range of conditions

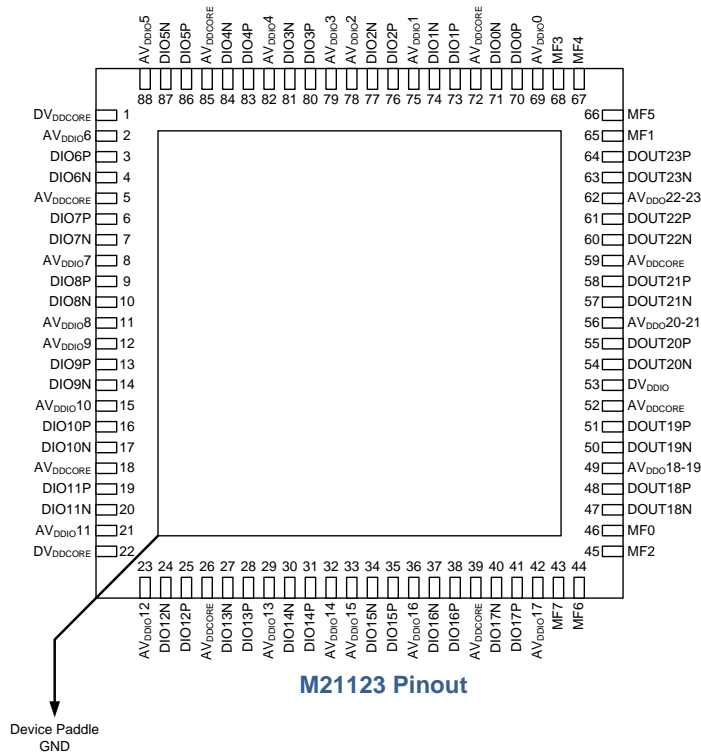

Package (RoHS Compliant)

12mmx12mm 88 pin QFN Package

For more product information, please visit www.mindspeed.com



www.mindspeed.com/salesoffices
 General Information: (949) 579-3000
 Headquarters – Newport Beach
 4000 MacArthur Blvd., East Tower
 Newport Beach, CA 92660-3007

© 2010 Mindspeed Technologies, Inc. All rights reserved. Mindspeed and the Mindspeed logo are trademarks of Mindspeed Technologies. All other trademarks are the property of their respective owners. Although Mindspeed Technologies strives for accuracy in all its publications, this material may contain errors or omissions and is subject to change without notice. This material is provided as is and without any express or implied warranties, including merchantability, fitness for a particular purpose and non-infringement. Mindspeed Technologies shall not be liable for any special, indirect, incidental or consequential damages as a result of its use.

