

HMIC Silicon PIN Diode SP3T Switch with Integrated Bias Network 2 - 18 GHz

Rev. V2

Features

- Broad Bandwidth Specified up to 18 GHz
- Usable up to 26 GHz
- Integrated Bias Network
- Low Insertion Loss / High Isolation
- Fully Monolithic
- Glass Encapsulate Construction
- RoHS Compliant* and 260°C Reflow Compatible

Description

The MASW-011053 device is a SP3T broad band switch with integrated bias networks utilizing MACOM's patented HMIC (Heterolithic Microwave Integrated Circuit) process. This process allows the incorporation of silicon pedestals that form series and shunt diodes or vias by imbedding them in low loss, low dispersion glass. By using small spacing between elements, this combination of silicon and glass gives HMIC devices low loss and high isolation performance with exceptional repeatability through low millimeter frequencies. Large bond pads facilitate the use of low inductance ribbon bonds, while gold backside metallization allows for manual or automatic chip bonding via 80/20 - Au/Sn, 62/36/2 - Sn/Pb/Ag solders or electrically conductive silver epoxy.

Ordering Information¹

Part Number	Package
MASW-011053-47300G	Die in Gel Pack
MASW-011053-47300W	Die in Waffle Pack

1. Die quantity varies.

Functional Diagram

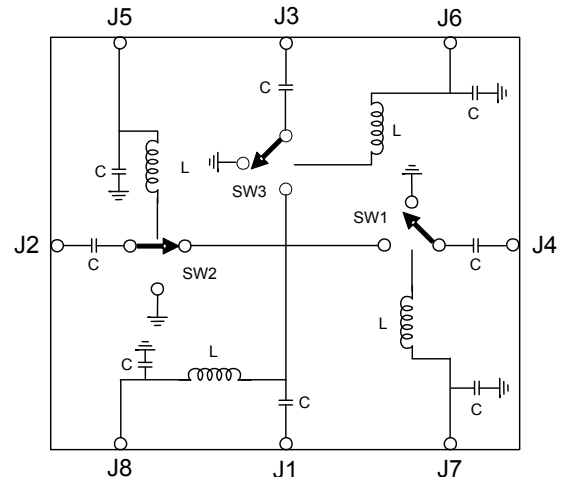

Pin Configuration²

Pin	Function
J1	Antenna
J2	RF _{IN}
J3	RF _{IN}
J4	RF _{IN}
J5	Bias of J2
J6	Bias of J3
J7	Bias of J4
J8	Bias of Antenna

2. The exposed metallization on the chip bottom must be connected to RF, DC and thermal ground.

* Restrictions on Hazardous Substances, European Union Directive 2011/65/EU.

HMIC Silicon PIN Diode SP3T Switch with Integrated Bias Network 2 - 18 GHz

Rev. V2

Electrical Specifications:

$T_A = +25^\circ\text{C}$, $Z_0 = 50 \Omega$, $P_{IN} = 0 \text{ dBm}$, DC Control Current = 20 mA (unless otherwise noted)

Parameter	Test Conditions	Units	Min.	Typ.	Max.
Insertion Loss	2 GHz	dB	—	1.0	2.0
	6 GHz			0.6	1.1
	12 GHz			0.8	1.3
	18 GHz			1.1	1.9
Input to Output Isolation	2 GHz	dB	54	62	—
	6 GHz		47	55	
	12 GHz		40	50	
	18 GHz		36	47	
Input Return Loss	2 GHz	dB	—	14	—
	6 GHz			15	
	12 GHz			16	
	18 GHz			14	
Input/Output IP3 @ 5 dBm	2 GHz	dBm	—	46.0	—
	6 GHz			48.8	
	12 GHz			50.8	
	18 GHz			45.0	
Input/Output IP2 @ 5 dBm	2 GHz	dBm	—	66.3	—
	6 GHz			66.8	
	12 GHz			66.0	
	18 GHz			68.3	
Switching Speed ³	—	ns	—	50	—

3. Typical switching speed measured from 10% to 90% of detected RF signal driven by TTL compatible drivers using RC output spiking network, $R = 50 - 200 \Omega$, $C = 390 - 560 \text{ pF}$.

Absolute Maximum Ratings^{4,5}

Parameter	Absolute Maximum
Forward Bias Current	60 mA
Reverse Bias Voltage (RF & DC)	50 V
RF Incident Power	33 dBm CW
Junction Temperature	+175°C
Operating Temperature	-65°C to +125°C
Storage Temperature	-65°C to +150°C

4. Exceeding any one or combination of these limits may cause permanent damage to this device.
5. MACOM does not recommend sustained operation near these survivability limits.

Handling Procedures

Please observe the following precautions to avoid damage:

Static Sensitivity

HMIC Integrated Circuits are sensitive to electrostatic discharge (ESD) and can be damaged by static electricity. Proper ESD control techniques should be used when handling these devices.

HMIC Silicon PIN Diode SP3T Switch with Integrated Bias Network 2 - 18 GHz

Rev. V2

Truth Table

DC Control Current ⁶			Condition of RF Output		
J5	J6	J7	J1-J2	J1-J3	J1-J3
-20 mA	+20 mA	+20 mA	Low Loss	Isolation	Isolation
+20 mA	-20 mA	+20 mA	Isolation	Low Loss	Isolation
+20 mA	+20 mA	-20 mA	Isolation	Isolation	Low Loss

6. The forward diode voltage drop between:
 J8 to J5, J6 or J7 is 1.0 V typical.
 J5, J6 or J7 to GND is 0.9 V typical.

Circuit Schematic

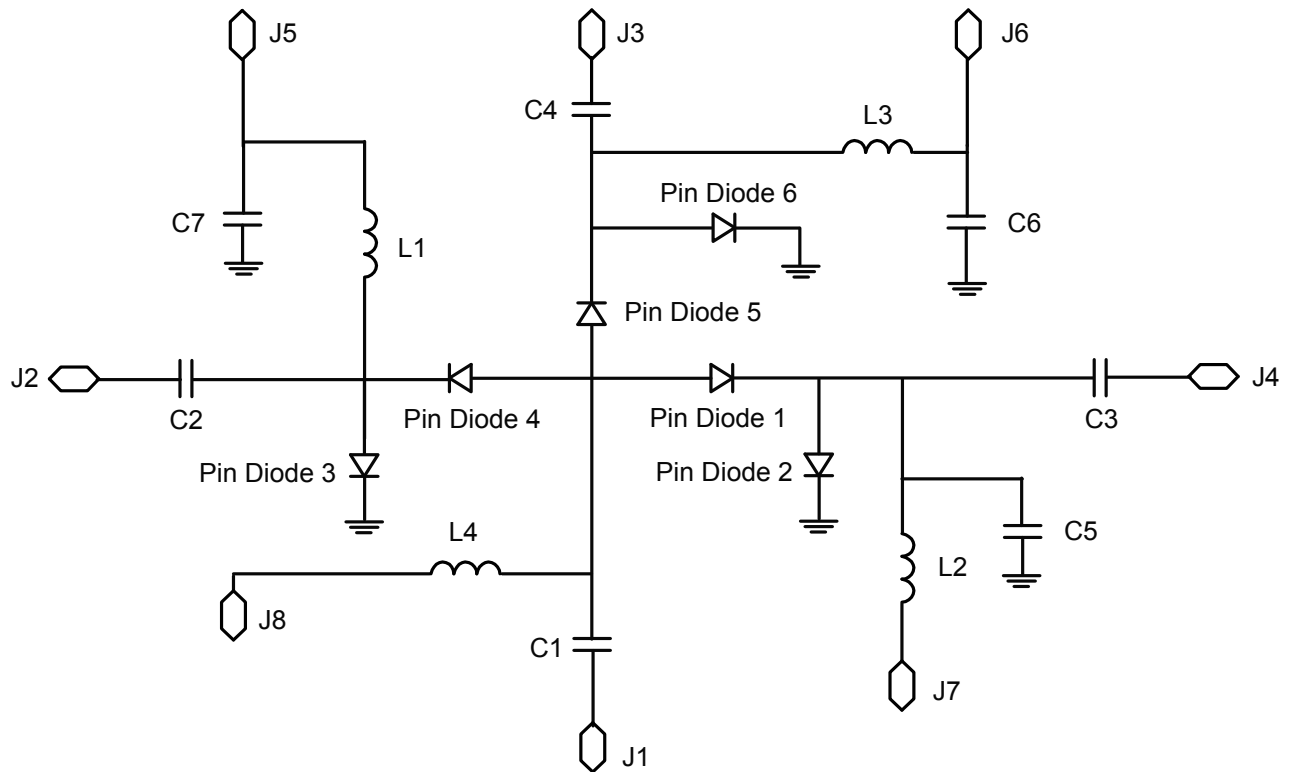

HMIC Silicon PIN Diode SP3T Switch with Integrated Bias Network 2 - 18 GHz

Rev. V2

Typical Performance Curves

Isolation @ 5 V, +25°C

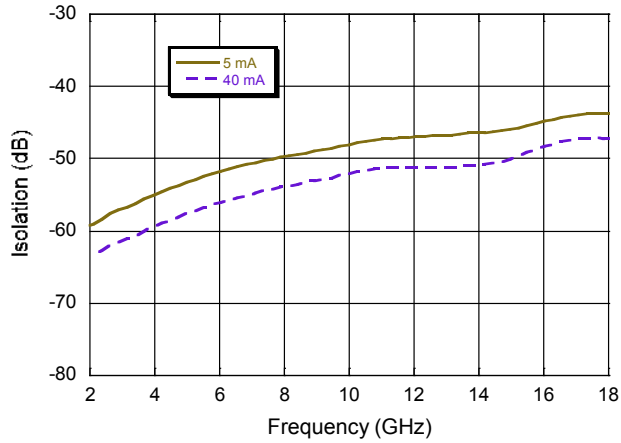

Isolation @ 5 V, 5 mA

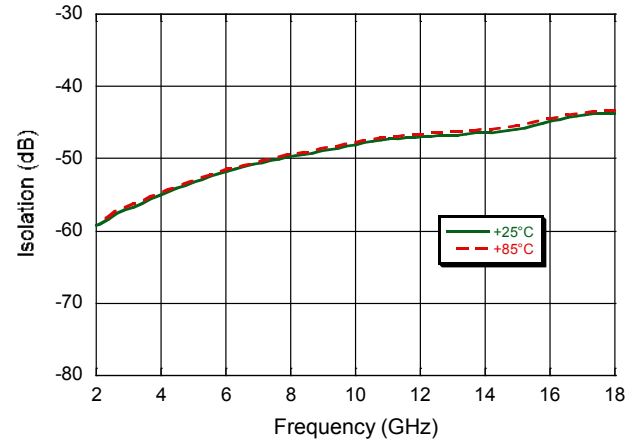

Insertion Loss @ 5 V, +25°C

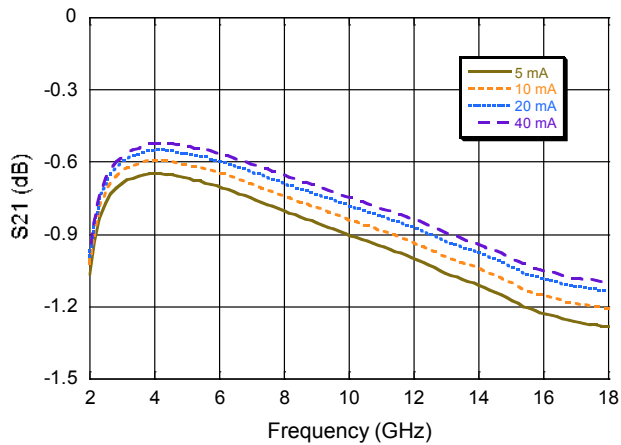

Insertion Loss @ 5 V, 20 mA

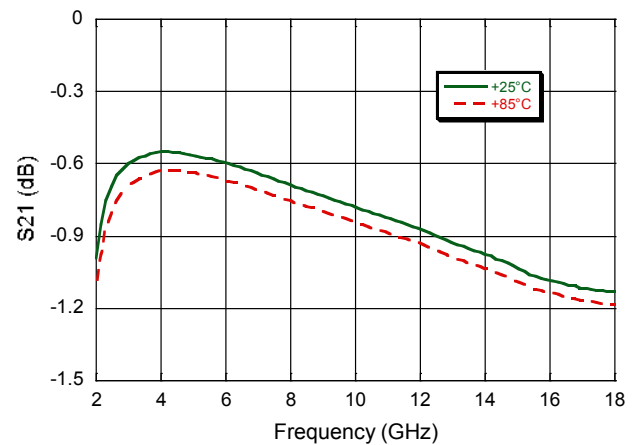

Input Return Loss @ 5 V, +25°C

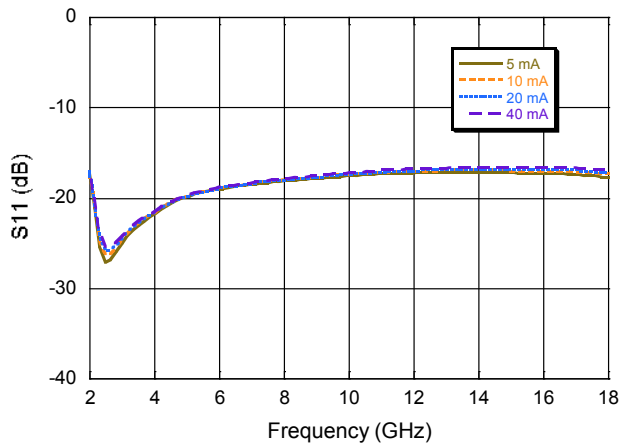

Output Return Loss @ 5 V, +25°C

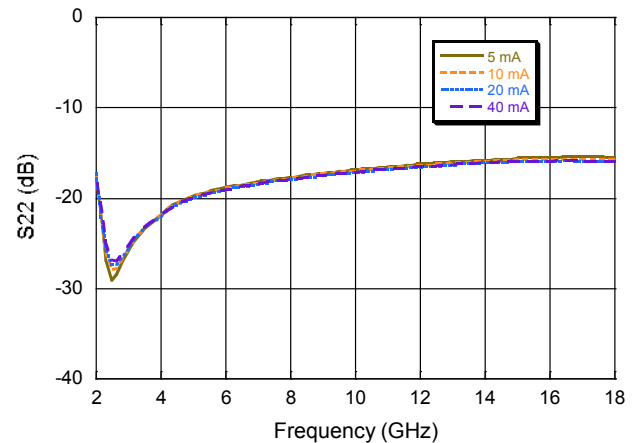

Typical Performance Curves

IP3

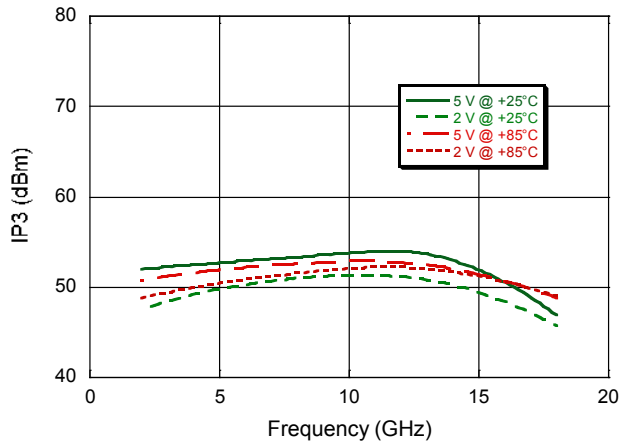

IP2

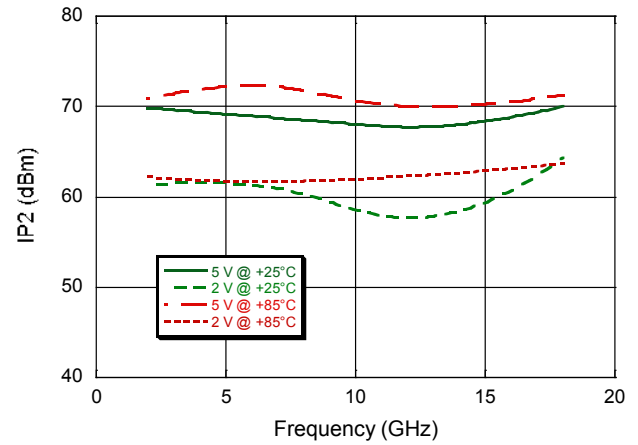

Junction Temperature

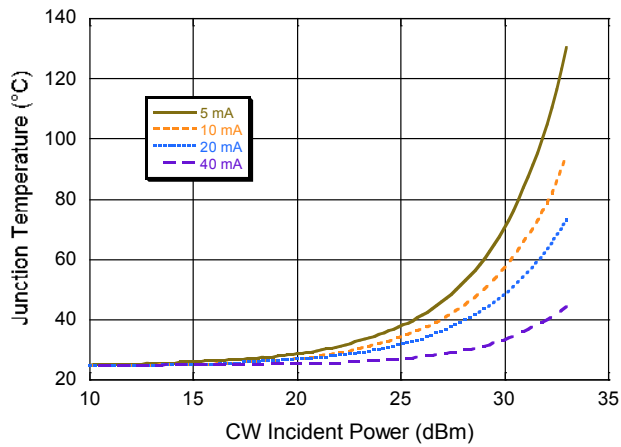

Compression Power

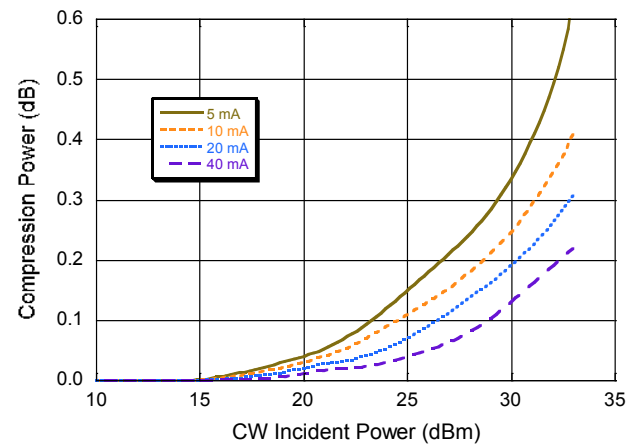

Wire/Ribbon and Die Attachment Recommendations

Wire Bonding:

Thermosonic wedge wire bonding using 0.00025" x 0.003" ribbon or 0.001" diameter gold wire is recommended. A heat stage temperature of 150°C and a force of 18 to 22 grams should be used. Ultrasonic energy should be adjusted to the minimum required to achieve a good bond. RF bond wires should be kept as short and straight as possible.

Mounting

The HMIC switches have Ti-Pt-Au back metal. They can be die mounted with a gold-tin eutectic solder preform or conductive epoxy. Mounting surface must be clean and flat.

Eutectic Die Attachment:

An 80/20, gold-tin, eutectic solder preform is recommended with a work surface temperature of 255°C and a tool tip temperature of 265°C. When hot gas is applied, the tool tip temperature should be 290°C. The chip should not be exposed to temperatures greater than 320°C for more than 20 seconds. No more than three seconds should be required for attachment. Solders containing tin should not be used.

Epoxy Die Attachment:

A minimum amount of epoxy should be used. A thin epoxy fillet should be visible around the perimeter of the chip after placement. Cure epoxy per manufacturer's schedule (typically 125-150°C).

Outline Drawing^{7,8,9}

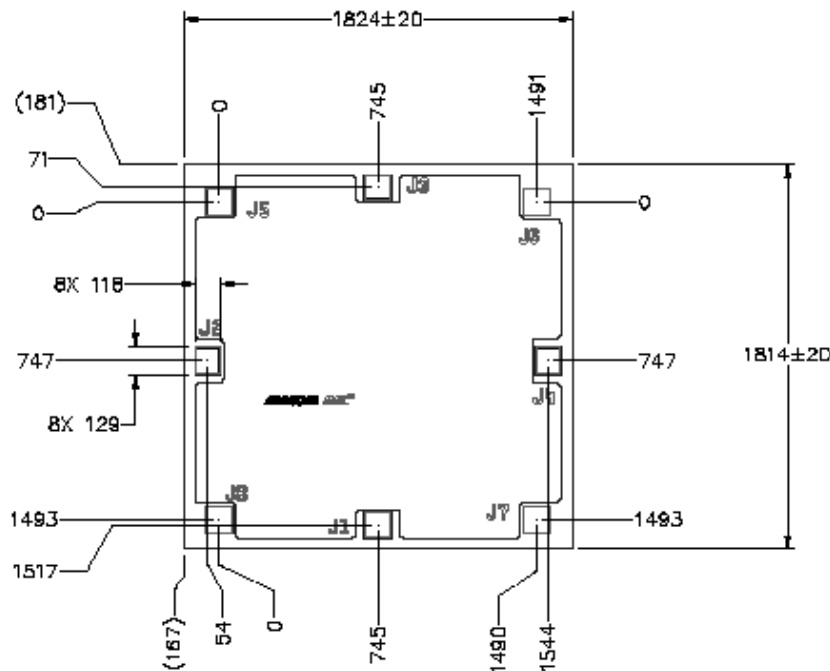

7. Unless otherwise specified, all dimensions shown as μm , with tolerance $\pm 5 \mu\text{m}$.
8. Die thickness is $125 \pm 10 \mu\text{m}$.
9. Topside and backside metallization is gold, $2.5 \mu\text{m}$ thick typical.

M/A-COM Technology Solutions Inc. All rights reserved.

Information in this document is provided in connection with M/A-COM Technology Solutions Inc ("MACOM") products. These materials are provided by MACOM as a service to its customers and may be used for informational purposes only. Except as provided in MACOM's Terms and Conditions of Sale for such products or in any separate agreement related to this document, MACOM assumes no liability whatsoever. MACOM assumes no responsibility for errors or omissions in these materials. MACOM may make changes to specifications and product descriptions at any time, without notice. MACOM makes no commitment to update the information and shall have no responsibility whatsoever for conflicts or incompatibilities arising from future changes to its specifications and product descriptions. No license, express or implied, by estoppel or otherwise, to any intellectual property rights is granted by this document.

THESE MATERIALS ARE PROVIDED "AS IS" WITHOUT WARRANTY OF ANY KIND, EITHER EXPRESS OR IMPLIED, RELATING TO SALE AND/OR USE OF MACOM PRODUCTS INCLUDING LIABILITY OR WARRANTIES RELATING TO FITNESS FOR A PARTICULAR PURPOSE, CONSEQUENTIAL OR INCIDENTAL DAMAGES, MERCHANTABILITY, OR INFRINGEMENT OF ANY PATENT, COPYRIGHT OR OTHER INTELLECTUAL PROPERTY RIGHT. MACOM FURTHER DOES NOT WARRANT THE ACCURACY OR COMPLETENESS OF THE INFORMATION, TEXT, GRAPHICS OR OTHER ITEMS CONTAINED WITHIN THESE MATERIALS. MACOM SHALL NOT BE LIABLE FOR ANY SPECIAL, INDIRECT, INCIDENTAL, OR CONSEQUENTIAL DAMAGES, INCLUDING WITHOUT LIMITATION, LOST REVENUES OR LOST PROFITS, WHICH MAY RESULT FROM THE USE OF THESE MATERIALS.

MACOM products are not intended for use in medical, lifesaving or life sustaining applications. MACOM customers using or selling MACOM products for use in such applications do so at their own risk and agree to fully indemnify MACOM for any damages resulting from such improper use or sale.