



Key Performance Features:

- Smooth 4-Pole Performance
- Dynamically Balanced Armatures
- IP 65 Sealing
- Round or Optional NEMA 42 Mounting
- 12-120 VDC Typical

C40 BRUSHED SERVO MOTOR SERIES

Motor Characteristics

FRAME SIZE	STACK LENGTH	PEAK STALL TORQUE (T _p) OZ-IN	CONT. STALL TORQUE (T _c) OZ-IN	ROTOR INERTIA (J _m) OZ-IN-SEC ²	FRICTION TORQUE (T _f) OZ-IN	THERMAL RESISTANCE (RM) °C/WATT	MAX RECOMMEND SPEED RPM	MAX WINDING TEMP. C°	POWER RANGE W	WEIGHT LB
C40	-- 200	1200	248	0.16	12	2.0	3000	155	275	10
C40	-- 300	1984	416	0.24	14	1.3	3000	155	430	13
C40	-- 400	2480	512	0.30	16	0.98	3000	155	570	15
C40	-- 500	3040	640	0.37	18	0.79	3000	155	720	17

Sample Windings

CONSULT MAGMOTOR APPLICATION STAFF FOR OTHER AVAILABLE WINDINGS

	C40 -- 200				C40 -- 300				C40 -- 400				C40 -- 500			
	A	C	E	G	A	C	E	G	A	C	E	G	A	C	E	G
Torque Constant (Kt) oz-in/amp	18.0	26.4	43.2	64.4	23.0	37.7	59.6	94.5	31.8	48.3	76.8	122.4	39.2	54.2	94.1	147.4
Voltage Constant (Ke) Volts/Krpm	13.3	19.5	32.0	47.6	17.0	27.8	44.1	69.9	23.5	35.7	56.8	90.5	29.0	40.1	69.6	109.0
Term. Resistance (Rt) Ohms (cold)	0.31	0.76	1.5	2.7	0.4	0.6	1.25	3.4	0.57	0.75	1.8	5.2	0.8	1.15	2.62	5.5
Peak Current (A) Amps	80	50	32	20	80	50	32	20	80	50	32	20	80	50	32	20
Cont. Current (A) Amps	17	10	7	4	17	10	7	4	17	10	7	4	17	10	7	4

VALUES AS LISTED ARE TEST CONDITIONS, ACTUAL RESULTS MAY VARY

▼ C40 Series Options

- Optical Encoders
- Tachometers, Brakes and Gearbox
- Application Specific Windings and Mechanical designs
- NEMA 42 Flange Mounting
- IP 65 Sealing
- For more options, see magmotor.com custom solutions, or call us.

▼ Typical Applications

- Coil Winders
- Textile Machines
- Machine Tools
- Electric Vehicles
- Packaging Machines
- Image Acquisition and Printing Equipment

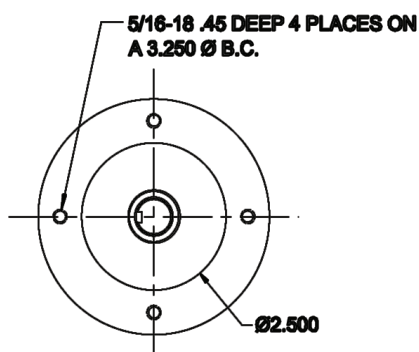
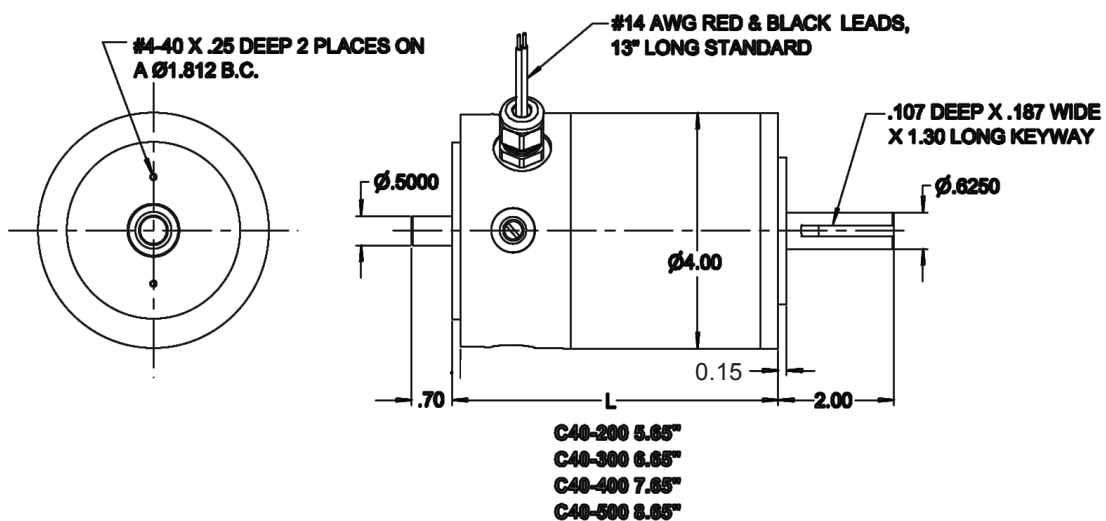

**STANDARD
ROUND FACE MOUNT**

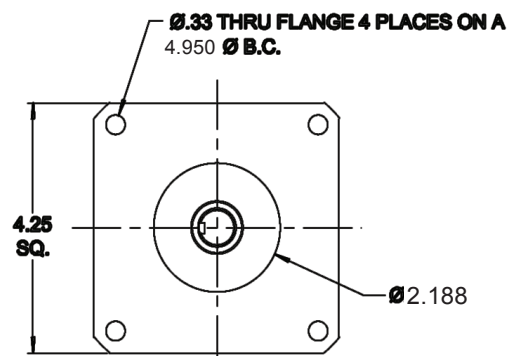

**NEMA 42
FLANGE MOUNT**