

PART MUST BE FREE OF ALL SCRATCHES AND BURRS.
UNLESS OTHERWISE SPECIFIED, REMOVE SHARP EDGES
BETWEEN 0.1 AND 0.3x45° OR EQUAL RAD. THIS PART
SHOULD BE PACKED SO AS TO AVOID DAMAGE DURING TRANSPORT.

MARS PROPRIETARY INFORMATION

CHNG/REV	DESCRIPTION	ECN No.	DATE	DWN	APPVD

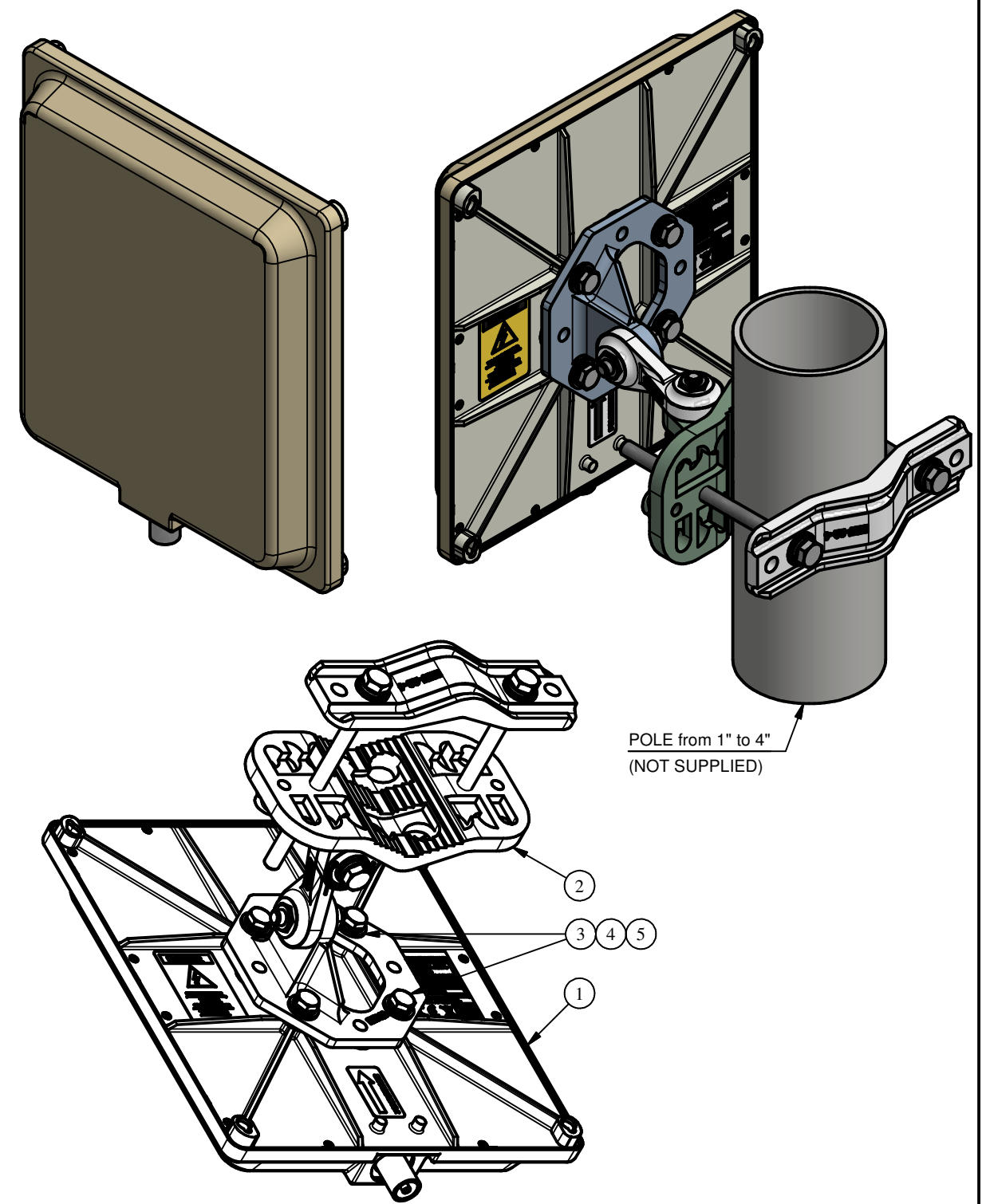
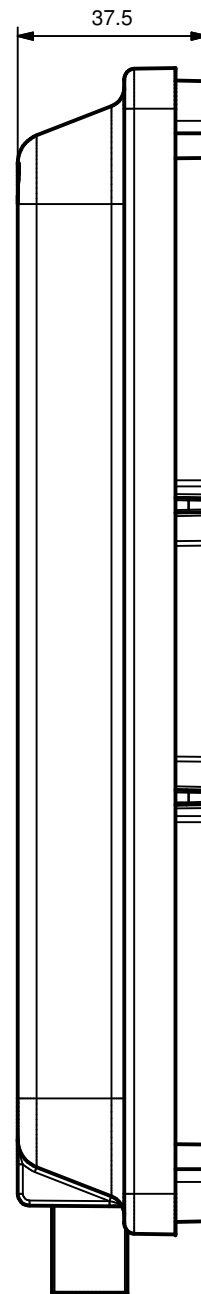
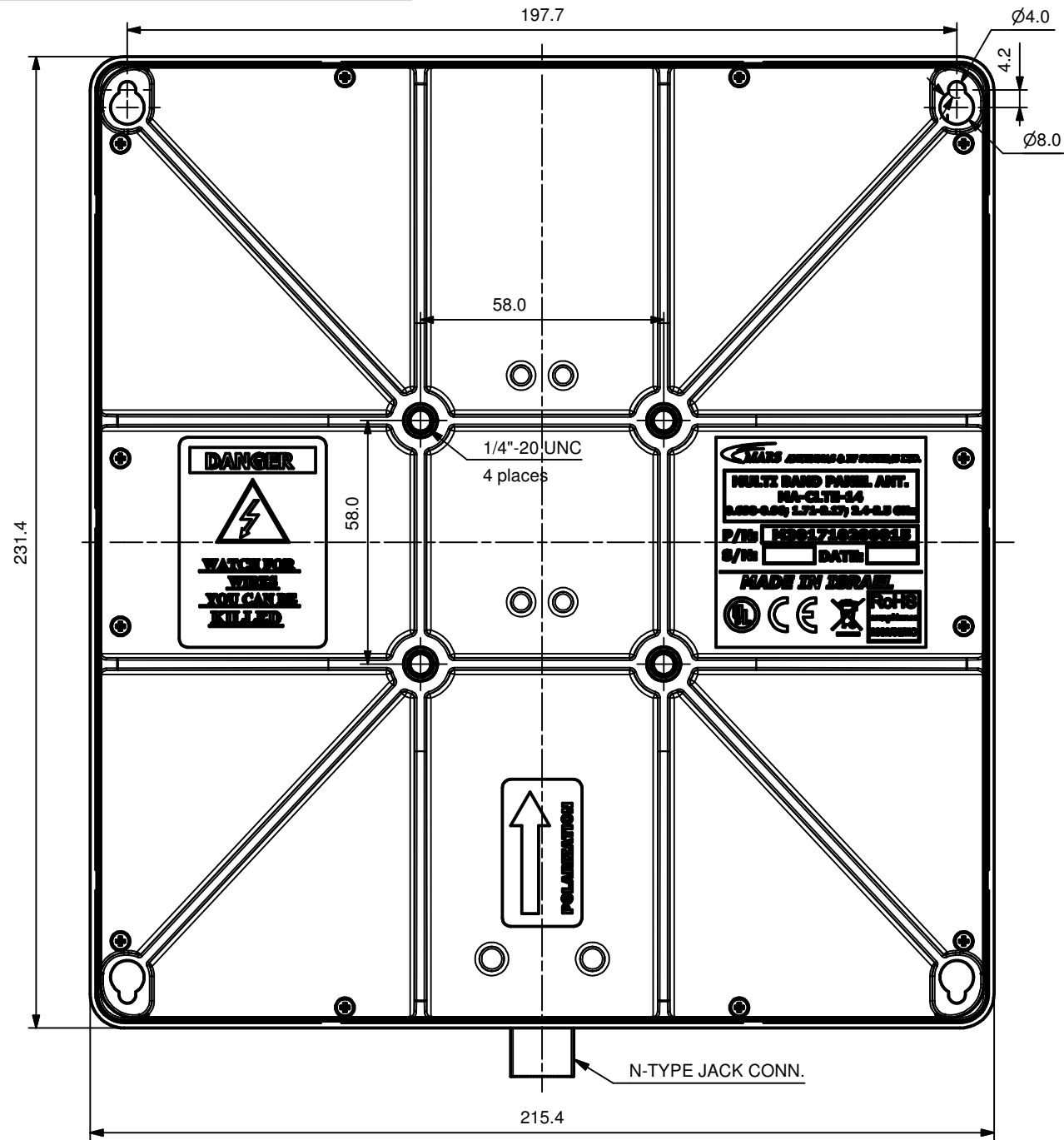

ITEM	QTY	PROJECT	PART NUMBER	DESCRIPTION
1	1	3017	10200015	Antenna MA-CTLE-14
2	1	2134	10200015	MNT-22
3	4		BM30001	Flat Washer 1/4"
4	4		BM30002	Helical Spring Lock Washer 1/4"
5	4		BM10232	Hex Cap Screw 1/4-20 UNC x 5/8"

NAME	DATE	SCALE:	 MA-CTLE-14 General View
DWN victor	14.05.2013	DIMENSIONS FOR REFERENCE ONLY <small>UNLESS OTHERWISE SPECIFIED DIMENSIONS ARE IN MM.</small>	
DESIGN victor	14.05.2013		
CHKD			
APPRD			
MATERIAL			
RoHS COMPLIANCE			
QTY	FILE NAME	SIZE	REF DWG NUMBER
		A3	PROJECT NUMBER REV
1		1	M 3017 10200005 0

Mounting instructions - Azimuth and Elevation Adjustable Mount MNT-22 REV. 5

Fig. 1

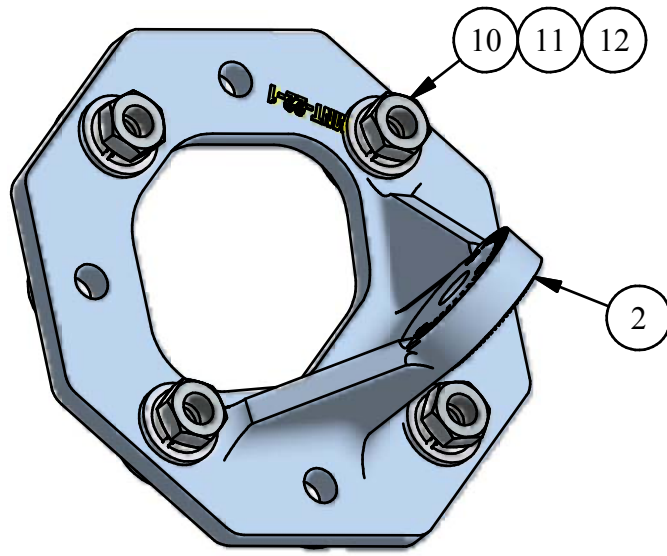

Fig. 2

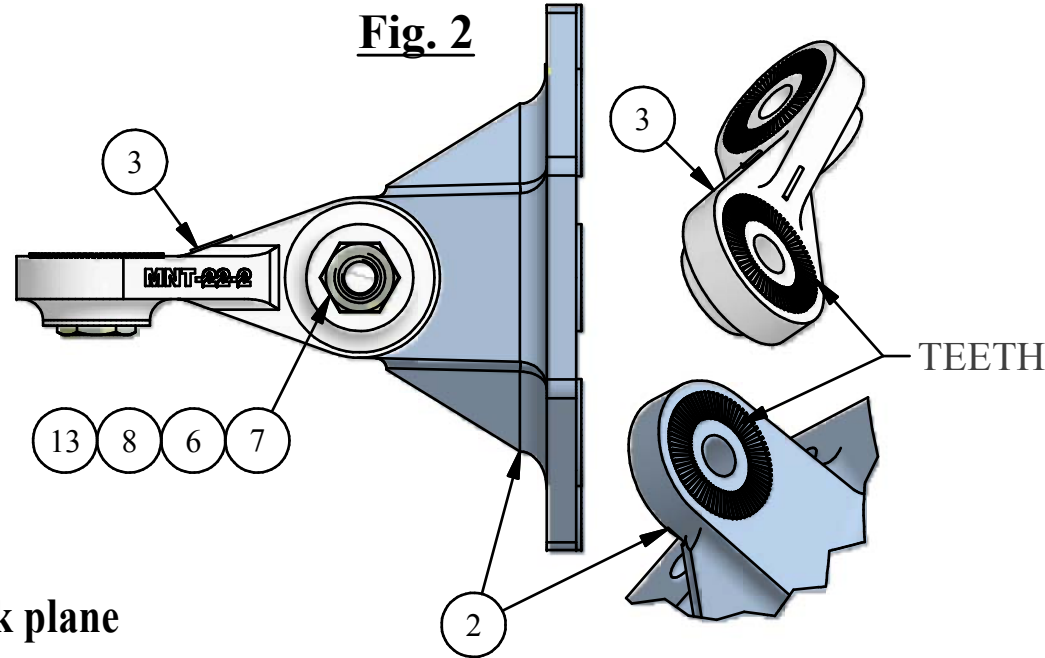
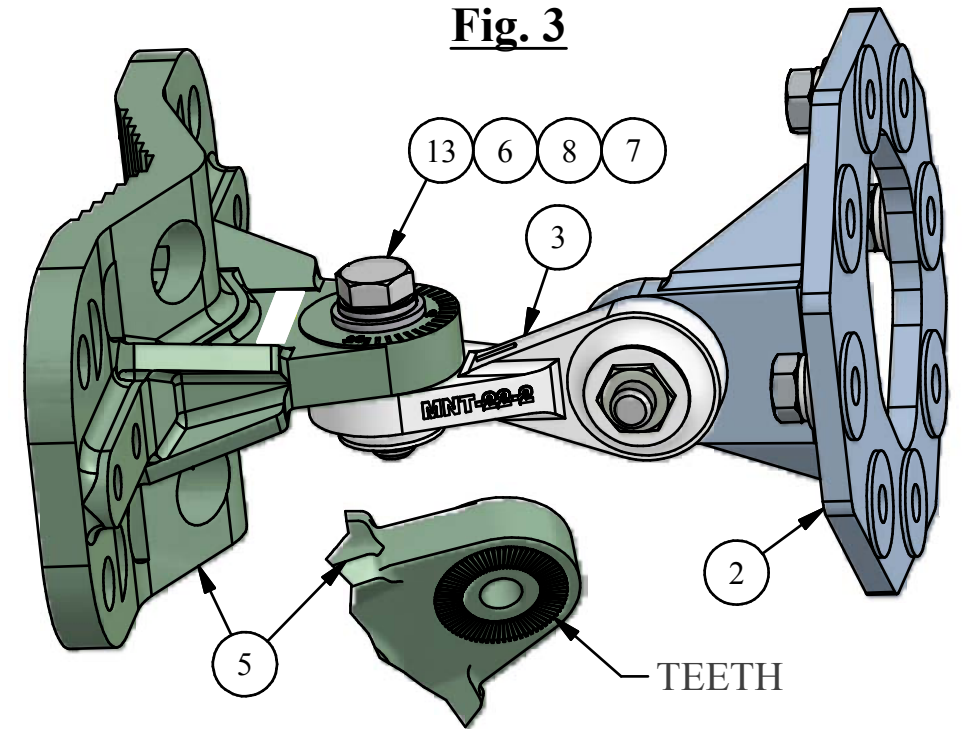

Fig. 3



1. Align holes of item 2 with 4 studs on back plane of the antenna (not shown).
2. Connect item 2 to the antenna with spring washers (11), plain washers (10) and nuts (12).
3. Tighten the nuts at a torque of 30 Lbs x In.

4. Align item 3 with item 2 so teeth of item 2 face teeth of item 3. Connect with items 6, 7, 8, 13. Leave screw slightly loose.

5. Align item 5 with item 3 so teeth of item 5 face teeth of item 3. Connect with items 6, 7, 8, 13. Leave screw slightly loose.

Fig. 4

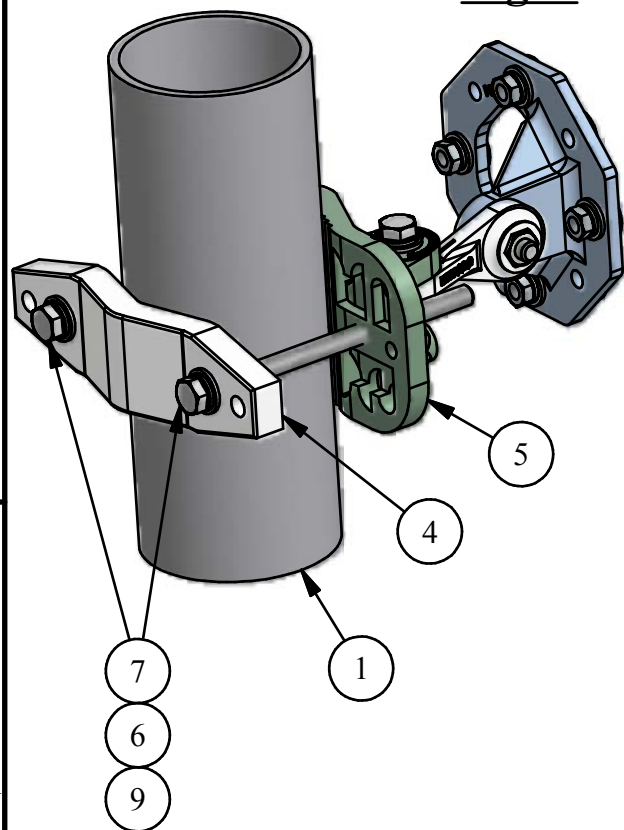

6. Attach items 4, 5 to the pole as illustrated, and connect them using items 6, 7, 9.
7. Close screws (9) one and another in turn up to tightening torque of each screw is 30...35 Lbs x In.
8. Distance between ends of items 4, 5 on one and another side must be equal. **NO SKEWNESS ALLOWED.**
9. Adjust the desired angle, and fully tighten the loose screws (paragraph 4, 5) at a torque of 30 Lbs x In.

Wall Mounting

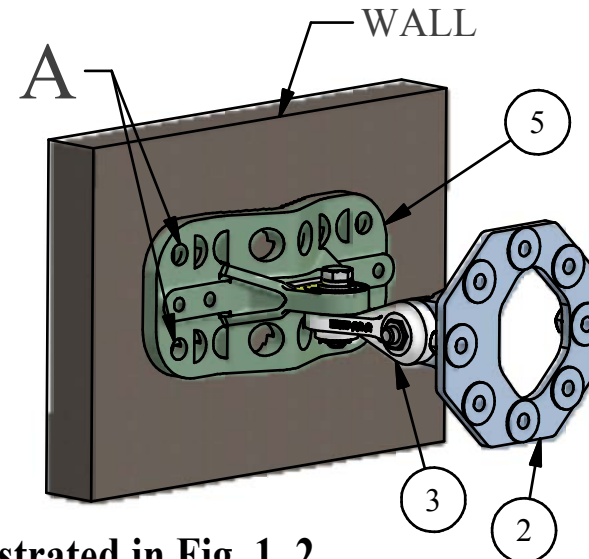

NOTE :

1. MOUNT SUITABLE FOR POLES \varnothing 1"-4".

10. Make assemblies as illustrated in Fig. 1, 2.
11. Attach item 5 to the wall. Fasten it with screws 1/4" or M6 using holes 'A'. (Screws not shown.)
12. Align item 3 with item 5 so teeth of item 3 face teeth of item 5. Connect as illustrated in Fig. 3.
13. Adjust the desired angle, and fully tighten the loose screws (paragraph 4, 5) at a torque of 30 Lbs x In.

Parts List		
ITEM	QTY	DESCRIPTION
1	1	POLE 1"-4" (NOT SUPPLIED)
2	1	MNT-22-1
3	1	MNT-22-2
4	1	MNT-22-4
5	1	MNT-22-3
6	4	Helical Spring Lock Washer St. St. #5/16
7	4	Plain Washer St. St. #5/16
8	2	Hex Cap Screw St. St. NC 5/16-18 x 1.25"
9	2	Hex Cap Screw St. St. NC 5/16-18 x 5"
10	4	Plain Washer St. St. #1/4
11	4	Helical Spring Lock Washer St. St.#1/4
12	4	Hex Nut St. St. NC 1/4-20
13	2	Hex Nut St. St. NC 5/16-18