

NEW

Overwhelming compact size and light weight design

Ultra compact DC programmable power supplies

RK-80 series

RK-80L : 16V_{max} / 10A_{max} / 80W

RK-80 : 36V_{max} / 5A_{max} / 80W

RK-80M : 110V_{max} / 1.3A_{max} / 80W

RK-80H : 320V_{max} / 0.5A_{max} / 80W

- ▶ Slim design of 1.4-inch in width
- ▶ Double output voltage / current range
- ▶ Available for the commercial AC voltage all over the world



Ultra Slim DC Power Supply

RK-80 series

“Ultra compact and light weight”

“Versatile and user-friendly design”



Ultra Slim Sophisticated Bench-top DC Power Supply

RK-80 series is a high performance DC programmable power supply. 3-digit digital meter is added newly. Needless to say, the innovative compact size, variable range feature and high operability are realized. RK-80 series is the suitable DC power supply for a variety of applications from laboratory experiment to line productions.



Compact and light weight space saving design



Very quiet due to the adopting naturally-cooled system without cooling fan.



For wider output range
 R4K-80L : 16V / 10A
 R4K-80 : 36V / 5A
 R4K-80M : 110V / 1.3A
 R4K-80H : 320V / 0.5A



Unique low noise power conversion technology for research application



Power factor correction and universal input



Multiple units operation with master / slave and digital interface

New user-friendly functions

New and useful functions and stylish front panel design!

NEW RK-80

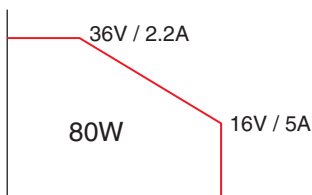

Useful new feature of variable setting range

Set voltage / current value within 80W, then turn on output.

*Not automatic range change which can output 80W all the time. Resetting is required.

Useful NEW 3 Additional Functions

NEW ■ Output voltage and output current can be set speedily.

When setting output voltage and output current by rotary encoder on front panel, every time fine switch is pressed, setting digit on digital display will be switched. In case, setting small output value or change setting value widely, setting can be done speedily. (Fine switch cannot be used when output value is set by remotely.)

- When output is OFF, the preset value can be displayed automatically by operating rotary encoder on the front panel.
- Various protections such as over voltage / current protection (OVP, OCP) are equipped as standard functions.

Lineup

Output voltage (V)	Output current (A)	Output Power(W)	MODEL	Ripple		Resolution *1		AC Input			Weight (typ)	
				(mVrms)	(mA rms)	Output volt.	Output cur.	Voltage	Current (typ)	Power factor (typ)		
0 to 16	0 to 10	80	RK-80L	5	10	0.1V	0.01A	85 to 264VAC 50 / 60Hz single phase	AC in 115V	AC in 230V	0.99 *2	950g
0 to 36	0 to 5		RK-80	5	5				1A *2	0.5A *2		
0 to 110	0 to 1.3		RK-80M	10	2	1V	1mA					
0 to 320	0 to 0.5		RK-80H	20	1							

*1 : The value at local control.

*2 : Maximum output @115VAC input.

MULTI SETTING FUNCTION

Function to memorize 3 different voltage and current settings in addition to standard preset function.

No need to adjust the output when different setting, and convenient function for production inspection process or testing which require frequent data taking.

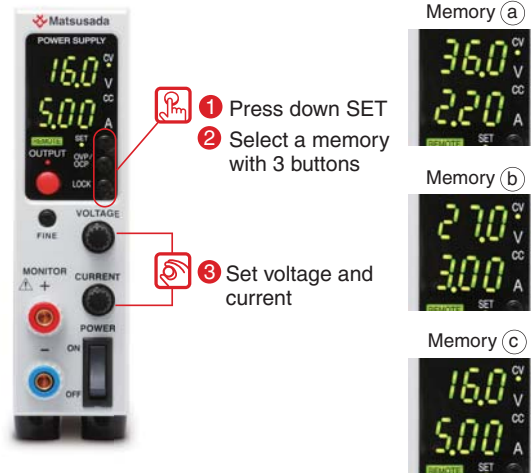

DELAY TRIGGER FUNCTION

(It is available only for one RK-80 when -LU1, -LGob or -LRmf option is selected.)

Function to output ON / OFF of total 32 units from one master unit. (when master / slave)

It is possible to delay the ON / OFF time, and simultaneous ON / OFF setting is possible as well.

Ideal function for application which require time delay for ON / OFF setting.

Master / slave is available only for the models with -LGmb option.

*1 : R4K-36 series, R4K-80 series, RK series and REK series. Detail catalog for each model is available. Please contact nearby sales office.

*2 : Can be connected up to 16 units.

*3 : Only for slave-local. In case of slave remote control, exact same model of power supply need to be used. Also, in case of slave-local, each output voltage and current can be set individually. In case of slave-remote, output voltage and current can be set with one-control function which each slave unit follows the master unit setting.

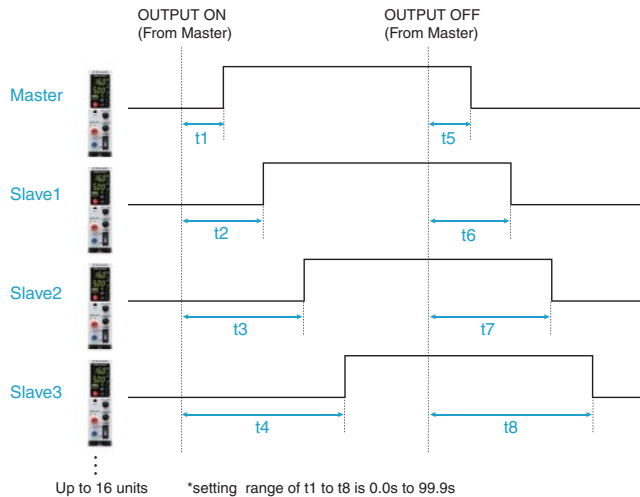

TWO MODE LOCK FUNCTION

Function to select two different lock functions for two different purpose. "Full Lock" locks all the function on front panel, and "Normal Lock" locks all the function except for ON/OFF. "Full Lock" mode shall be good in case mis-operation have to be completely avoided, and "Normal Lock" mode shall be good in case to avoid mis-operation but secure the way for emergency stop of power supply. You can select the best mode according to your level of "Security".

(in both modes, emergency stop is possible with Power Switch.)

Full LOCK

Lock all the function other than reset lock mode, and effective for purpose to avoid mis-operation when controlled.



Normal LOCK

Lock voltage and current setting dial, and effective for purpose to avoid changing output setting by mistake or when easy emergency stop is required.



Sink Current / Sink Current Prevention Function

RK-80 series features **function to sink current**, and enable to decrease the voltage quickly when turning off the output or when control the voltage down, which increase the safety of operation.

In case that continuous aging test in short interval, quick voltage fall time increase the efficiency of process. On the contrary by using **sink current prevention** function, it is possible to prevent voltage drop on the load by decreasing the current flow from load to power supply when turning off the power supply or when decrease the output voltage.

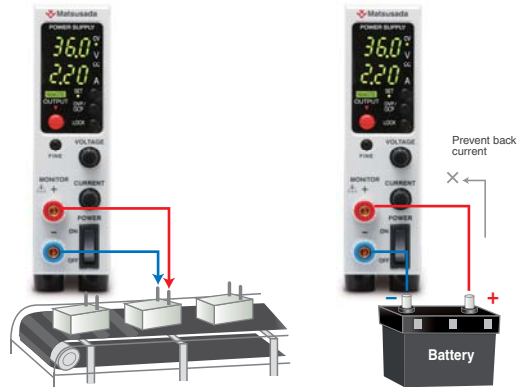

<NOTE> It is not possible to stabilize the output by controlling back current. In case of load which has inverse voltage, such as inductive load or regenerative motor, protect the power supply by adding dummy resistor or diode to prevent back current.

Dual Tracking, Multiple Outputs

Dual tracking control, which enables both positive and negative outputs simultaneously in master slave operation, is possible. Multi outputs and various versatile operations are also possible by combining above dual tracking control and slave local mode. Positive and negative output (+V,-V) of dual tracking control and set output voltage of slave local mode can be output simultaneously by turning on the master unit.

*Please refer to P.10 for detail connection.

Dual Tracking

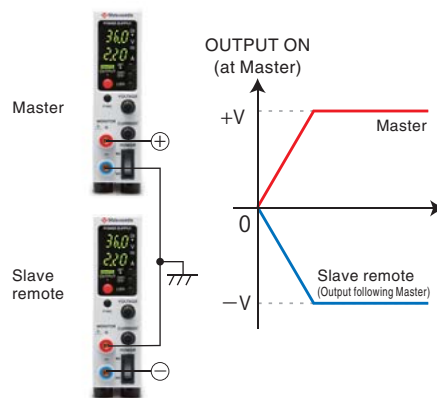

Multiple Outputs

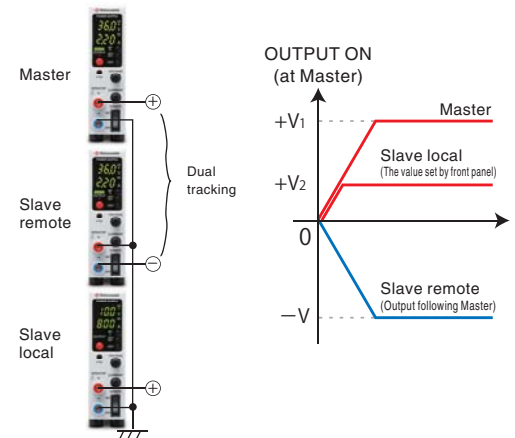

REMOTE FUNCTIONS

Remote switch ON / OFF

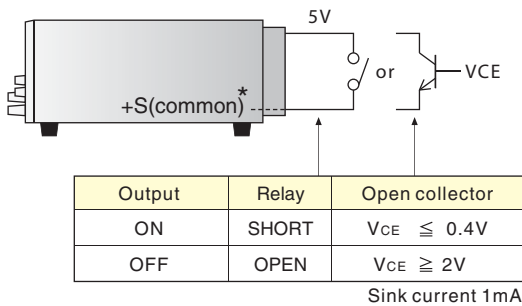

*+S is common. So external control voltage shall be input with +S as reference. Otherwise it can cause failure.

Remote sensing

Compensate the voltage drop ($V_0 - V_L$) due to resistance of output lead or drop of stability by contact resistance. (maximum 0.5V)

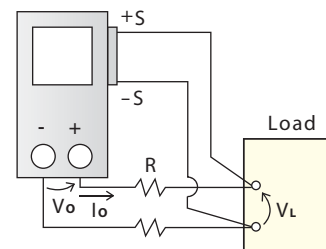

Actual size

Front panel

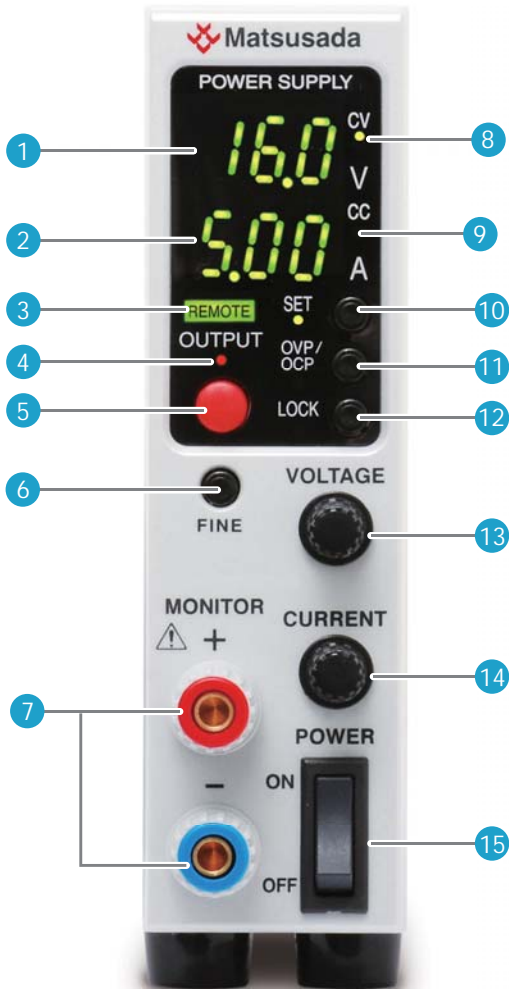

Rear panel

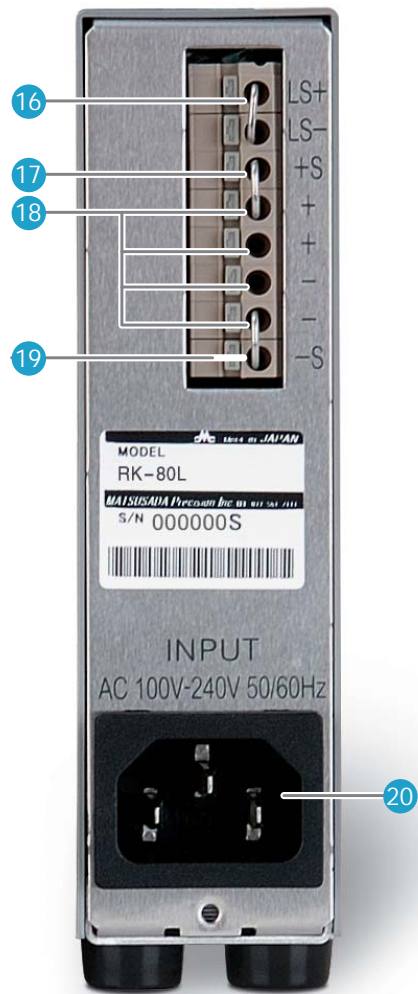

- ① Output voltage and OVP setting display
- ② Output current and OCP setting display
[RK-80H : mA display]
- ③ Remote programming display
Light up when output voltage / current control in remote mode.
- ④ Output display
Light up when output is on.
- ⑤ OUTPUT ON / OFF switch
To be used to turn output on / off when local mode as well resetting protection functions.
- ⑥ FINE switch
To shift the digit of a setting value of output voltage / current.
- ⑦ Monitor terminal
- ⑧ Constant voltage operation mode display
- ⑨ Constant current operation mode display

- ⑩ PRESET switch
- ⑪ OVP / OCP switch
- ⑫ LOCK switch
- ⑬ Output voltage · OVP setting dial
- ⑭ Output current · OCP setting dial
- ⑮ Power ON / OFF switch
This has priority over all operations for safety reason.
- ⑯ LS switch (remote switch)
- ⑰ +Sense
- ⑱ Output terminal
- ⑲ -Sense
- ⑳ AC input terminal

SPECIFICATION

Output Control	CV Mode : By rotary encoder on front panel Setting resolution of output voltage is 1 / 256 of rated maximum voltage CC Mode : By rotary encoder on front panel Output current setting accuracy is 1/256 of rated maximum output current. Remote control is option. See OPTION for remote control function.
Output Function	Wide output range, automatic limit setting at 80W for voltage and current In CV mode output current drop down when output power is more than 84.05W In CC mode output voltage drop down when output power is more than 84.05W
Lock Function	Lock function locks the output voltage and current setting
Output Display *1	Voltage : 3-digit digital meter. Accuracy is $\pm 0.2\%$ FS ± 4 digits (Accuracy of preset setting is $\pm 0.2\%$ Setting $\pm 400\text{mV}$) *2 Current : 3-digit digital meter. Accuracy is $\pm 0.4\%$ FS ± 5 digits (Accuracy of preset setting is $\pm 0.4\%$ Setting $\pm 50\text{mA}$) *2
Temp.coefficiency	$\pm 0.01\%$ / °C (at CV mode), $\pm 0.02\%$ / °C (at CC mode)
Protection	Over voltage protection (OVP) : Cut off the output at set value Setting range : appx. 5% to 110% of rated maximum voltage Setting : By front panel rotary encoder Reset : By output ON / OFF switch or remote switch (manual control) Over current protection (OCP) : Cut off the output at set value Setting range : appx. 5% to 110% of rated maximum current Setting : By front panel rotary encoder Reset : By output ON / OFF switch or remote switch (manual control) Over temperature protection. (OTP) : Cut off output at abnormal inside temperature. Reset (after temperature get down to normal temperature) : Output ON / OFF switch or Remote switch (manual control) Input brownout(ACF) · Blackout protection Output is cut off when input voltage decreased. Reset (when normal voltage value or recovery from blackout) : Manual recovery by OUTPUT switch or remote switch for blackout protection(re-output protection function). : Automatic recovery when blackout protection is canceled. Sense reverse connection
Other Functions	Remote switch ON / OFF (TLL or external relay), Remote sensing Delay trigger : Individual setting of ON delay and OFF delay (0.0 to 99.9sec) Multi setting function : Voltage and current memory "a", "b" and "c" setting in addition to standard voltage and current preset
Operation Temp.	0°C to 40°C
Storage Temp.	-20°C to +70°C
Storage humidity	20% to 80% (no condensation)
Isolation voltage	16V and 36V models : $\pm 250\text{V-DC}$ (Positive or Negative terminal grounding) 110V and 320V models : $\pm 500\text{V-DC}$ (Positive or Negative terminal grounding)
Leak current	0.5 / 1mA typ. (ACIN 100V / 200V 60Hz)
Dielectric voltage	Between input power supply and output terminal : AC1500V 1min. Between input power supply and chassis : AC1500V 1min. Between output terminal and chassis : DC500V 1min.

*1 : At 1% to 100% of rated output.

*2 : The accuracy of the preset value varies according to rated output value of each product.
Refer to the following table.

Voltage	Model	Accuracy of preset value
up to 9V	_____	$\pm 0.2\%$ setting $\pm 4\text{mV}$
10V to 99V	RK-80L, RK-80	$\pm 0.2\%$ setting $\pm 40\text{mV}$
more than 100V	RK-80M, RK-80H	$\pm 0.2\%$ setting $\pm 400\text{mV}$

Current	Model	Accuracy of preset value
up to 999mA	RK-80H	$\pm 0.4\%$ setting $\pm 0.5\text{mA}$
1A to 9A	RK-80, RK-80M	$\pm 0.4\%$ setting $\pm 5\text{mA}$
10A to 99A	RK-80L	$\pm 0.4\%$ setting $\pm 50\text{mA}$

ACCESSORIES

- Input AC cable 2.5m single phase 3-pin type(1)
- Instruction manual(1)
- Ground plate(1)



* For safer operation, connect ground plate and output terminal.

Dimensions inch(mm)

Front

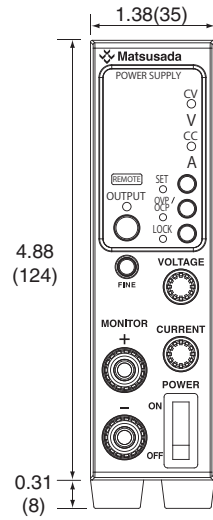

Rear

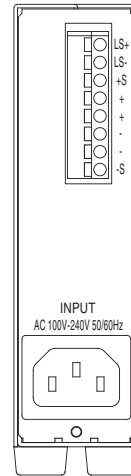

side

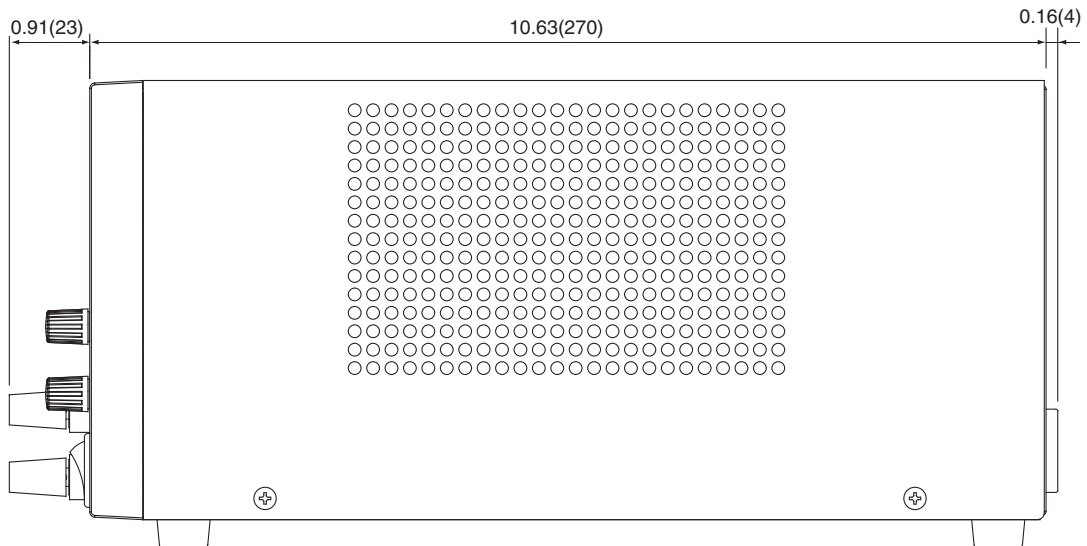

Options

-LGmb Digital interface board *1 *2

- LGmb : Digital interface + modular cable 2m length
- LGmb(Mc0.15) : Digital interface + modular cable 0.15m length
- LGmb(Mc0.5) : Digital interface + modular cable 0.5m length

Enable digit control via LAN(Ethernet *3) / USB / RS-232C / RS-485 / GPIB as well as one control with Master / Slave.

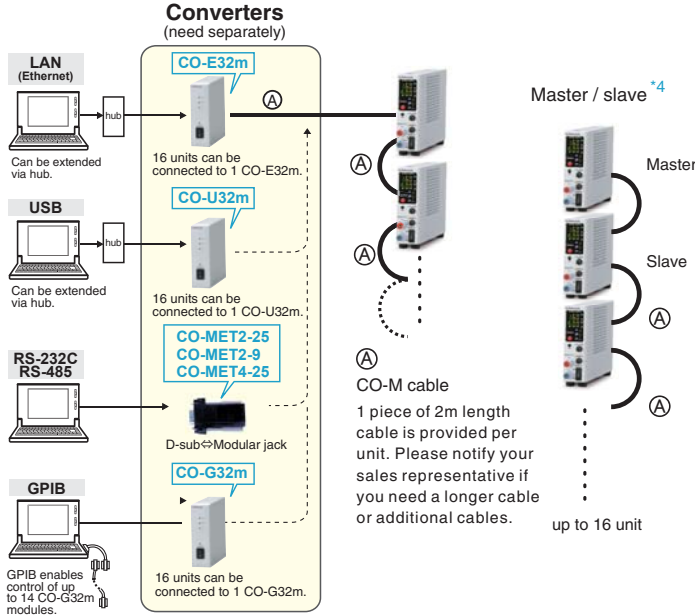

When noisy environment is presumed, the following -LGob option(optical interface) is required.

-LGob : Optical Interface Board *1 *2

- LGob : Optical interface board + optical cable 2m
- LGob(Fc5) : Optical interface board + optical cable 5m
- LGob(Fc10) : Optical interface board + optical cable 10m
- LGob(Fc20) : Optical interface board + optical cable 20m
- LGob(Fc40) : Optical interface board + optical cable 40m

Optical communication offers insulation control. It is to prevent malfunction such as transient phenomenon by surge, lightning induction, and exogenous noise.

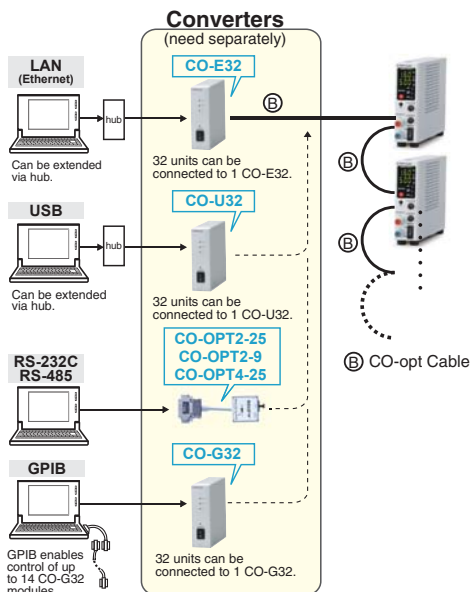

- Select the -LGob option when using power supply following environmental condition
- Factories which has a lot of noise (ex.)in case of using power supplies and loads near motors and coils.
 - In case using power supply with high voltage floating(more than 250V)
 - The length between power supply and controller unit(PC or PLC) is more than 2-meter

-LU1 USB Interface Board *1 *2 *4

When controlling several RK-80 power supplies via USB, a USB hub will be required between the PC and RK-80 power supplies.

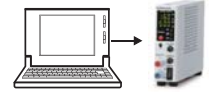

-LRmf Remote multi function *1

Output control

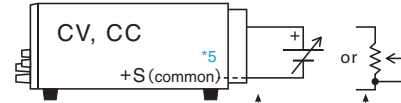

Vout · Iout	Vcon · Icon	R
0 to MAX	0 to 10Vdc approx.	0 to 10kΩ approx.

At the time of the remote control, it performs "operation to change 3 ranges" as follows.

model	Switch number	Range	Rated output voltage	Rated output current
RK-80L	1	High	16V	5A
	2	Middle	10V	8A
	3	Low	8V	10A
RK-80	1	High	36V	2.2A
	2	Middle	27V	3A
	3	Low	16V	5A
RK-80M	1	High	110V	0.7A
	2	Middle	80V	1A
	3	Low	60V	1.3A
RK-80H	1	High	320V	200mA
	2	Middle	250V	300mA
	3	Low	160V	500mA

- *1) These options can be chosen only one either.
- *2) For detailed specification of USB and digital interface, please refer date sheet of CO series.
- *3) Ethernet is the registered trademark of Xerox corporation.
- *4) Delay trigger function can be set individually at the time of master-slave. Furthermore, all functions (except OUTPUT) of master-slave can be also canceled by the change of Remote / Local, and the preset value of output voltage / current can be set individually.
- *5) +S is common. So external control voltage shall be input with +S as reference. Otherwise it can cause failure.

How to order

Add above -L mark to the model number when ordering
(e.g) RK-80-LGmb(Mc0.5), RK-80L-LGob(Fc20)
alphabetical order

Series Operation · Parallel Operation

RK-80 power supply of same model number can be connected in series or parallel to increase output voltage or current. In that case, local control or the control in the digital master slave is recommended. Because the common of the outside input / output control connector (TB1) is connected to the positive output, please do not connect common more than two.

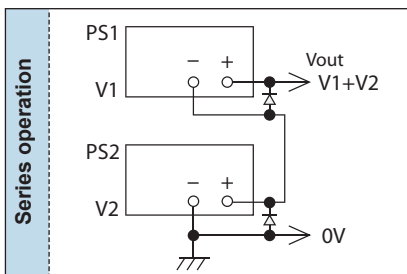

Total output voltage is to be up to 250V. Therefore for models with output voltage of over 250V, series operation cannot be conducted. Output current is to be the smallest current of those.

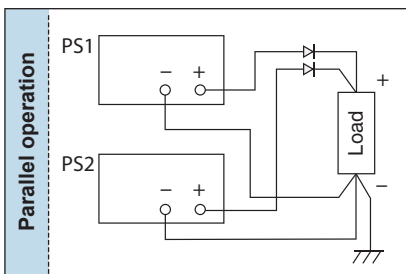

Please keep all the settings of voltage the same. Output current will be the summation of each current. Please keep OVP level of power supply maximum to prevent any damage.

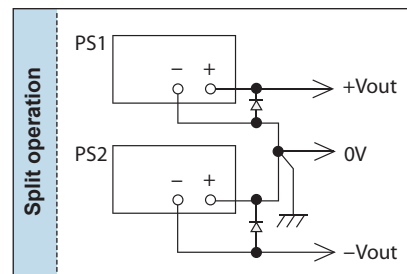

+output and -output are available.

AC Input Cable

CABLE TYPE 1 (standard)	CABLE TYPE 3 (separate)	CABLE TYPE 4 (separate)
125V / 10A	250V / 10A	250V / 10A

Accessory Kit

Various accessories are available for convenient use of the unit.

■ Stand



For one unit operation...



■ Binder



For the applications which require 2 to 6 units combination. Dual, triple and quad multiple operation is possible.

*Cooling fan is needed for more than 3 units combination.



■ Rack mount holder [RMO series]



- 10 Units/1 rack holder, and can be placed in a cabinet. Easy to take one unit out.
- Best suitable for a system operation.
- With fan unit.

*Power supply is not included in the accessories.

Connection · Operation

■ Connection of load

- Please use a short lead wire that is sufficiently thick for the connection.
- Please use PVC electric cable (105°C) that can fully tolerate the voltage used. It is necessary to consider current capacity, length limit of output wire by sensing (0.5V/lead) and so on for wiring with load. Please refer to the following diagram to determine the thickness of cable.

AWG	mm ²	Max current(A)
18	1.1	2
16	1.3	7
14	2.1	11
12	3.3	18
10	5.3	23
8	8.4	39
6	13	67

■ Parallel connection of load

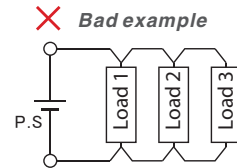
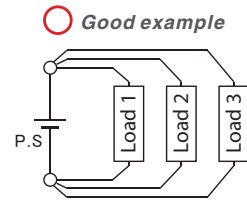

Definition of specifications

Specifications in this catalog, except otherwise specified, refer to values when maximum rating output (full scale*) after 2-hour warm up.

Applicable scope of specifications

"F.S × catalog value(★)" is applied for ripple, stability, regulations and temperature coefficient, and "value if F.S × ±0.5%(★)" is applied for high-voltage output linearity, monitor linearity and display linearity, both in the range of 10% to 100% of maximum rating output.

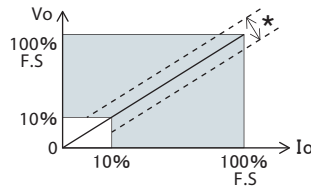

Ripple

Indication is in rms that includes high-frequency noise.

Preset

Preset value does not show the actual output status accurately. If you need an accurate setting, conduct actual output without load and set a voltage. Also for setting current, conduct output after shorting the output terminal and gradually raise current before setting at a desired value.

When selecting DC power supply

► Important Notice

Products on this catalog have been manufactured with consideration of safety as DC power supply, however please follow instruction manual for operation and make sure to ground the ground terminal for your safety.

Products on this catalog have been manufactured on the precondition that they are used in ground electric potential or within the range of the above series operation. Please contact our sales staff when using the product for floating of high electric potential, etc.

Products on this catalog are manufactured with consideration for protection against load discharge. However for specific experiment or continuous discharge such as sputtering, product may need discharge resistance between power supply and load or could not be used at all. Please consult with our sales staff in advance.

We recommend that you contact our sales staff with your requirement before choosing a product so that you can get the best product and the safety as high-voltage equipment is assured.

