

**NEW**

# Four-quadrant fast response bi-polar power supply

**DHOP series**

- ▶ Output voltage : 0V to  $\pm 45\text{V}$
- ▶ Maximum output power : 240W
- ▶ Frequency bandwidth : DC to 100kHz



# DHOPseries



## Four-quadrant fast response bi-polar power supply

DHOP series is **four-quadrant bi-polar power supply which source and sink electric power**. They can be used in 2-mode of a constant voltage (CV) or a constant current (CC). Thanks to the original design, phenomenal light weight and compact size power supply, which is 8.3" (210mm ) width, and weigh 7kg has been achieved. They are ultra compact and high speed, driving output proportional to the input waveform such as a sine wave, triangular wave, saw wave, and square wave.

DHOP series is most appropriate for evaluation test such as solar panels, the instruments driven by battery and the IC which control battery.

Even faster model, DOS series, amplifier with function generator, DOPF series, or more high power model, DOP series, are available. Contact to local sales office for details.

### Applications

- ▶ Suitable to evaluate battery driven equipment to use as a simulated battery
- ▶ Inductive load such as coil and transformer
- ▶ Capacitive load like capacitor
- ▶ Various motor tests
- ▶ voltage regulation tests for in-vehicle electrical component
- ▶ Evaluation test for solar panel related devices
- ▶ For surface treatment

### Features

#### 1 Response speed

Newly developed DHOP series is the most appropriate for transient response test with such high power and broad bandwidth.

#### 2 DC bias

10-turn potentiometer to be used for the output setting volume when used as the DC power supply and for the bias setting when used as AC power supply is equipped.

#### 3 DC output meter

3-digit digital meter displays the DC value of the output voltage and current.

#### 4 Compact & light weight

For maximum compactness and light weight, DHOP Series has been improved for small footprint and easy carry.

#### 5 Constant voltage (CV) / Constant current (CC)

A single switch selects between CV and CC modes.

#### 6 Four-quadrant action

DHOP series can be used both as a high speed response DC power supply and as an electronic load.

#### 7 Complete protective function

Protective function against over voltage/current and protective measures against output short-circuit are completely provided.

## Lineup

★ Please consult with our sales office about the specifications except the following list.

| Model            | Output voltage<br>V(rms value) | Output current<br>A (rms value) | Output power<br>W | Frequency bandwidth<br>kHz (-3dB) | Weight<br>kg approx. |
|------------------|--------------------------------|---------------------------------|-------------------|-----------------------------------|----------------------|
| <b>DHOP20-12</b> | ±20 (14)                       | ±12 (8.4)                       | 240               | CV mode : DC to 100 kHz           | 7                    |
| <b>DHOP45-5</b>  | ±45 (31.5)                     | ±5 (3.5)                        |                   | CC mode : DC to 10kHz             |                      |

## Specifications

|   |  |
|---|--|
| <b>Input voltage</b>                          | 85V to 264Vac / 50/60Hz / single phase   |
| <b>Input current</b>                          | 6A max @ 115Vac input  |
| <b>External control voltage<br/>(Vcon-in)</b> | -10V to +10V<br>(input impedance : more than 10kΩ)   |
| <b>Output voltage limit</b>                   | Variable from 0 to approx.110% with<br>frontpanel VR   |
| <b>Output current limit</b>                   | Variable from 0 to approx.110% with<br>frontpanel VR   |
| <b>Output display<br/>(DC value)</b>          | Voltage : 3-digit digital meter ±999<br>Current : 3-digit digital meter ±999                             |
| <b>DC bias</b>                                | -100% to +100% by 10-turn potentiometer  |
| <b>Ripple</b>                                 | <CV mode> less than 0.1%rms<br><CC mode> less than 0.4%rms   |
| <b>Stability</b>                              | 0.016%/Hr typ.   |
| <b>Setting accuracy</b>                       | ±0.5%F.S.  |
| <b>Distortion</b>                             | <CV mode> 0.05%<br><CC mode> 0.5% (at rated output or resistor load)                                     |
| <b>Regulation</b>                             | Input : 0.05% (for ±10% input change)<br>Load : 0.05% (for 10% to 100% load change)                      |
| <b>Temperature coef.</b>                      | 0.02% / °C   |
| <b>Output monitor</b>                         | Output voltage : -10V to +10V ±1%F.S.<br>Output current : -10V to +10V ±1%F.S.<br>Output impedance : 1kΩ |
| <b>Protections</b>                            | Over voltage protection, over current<br>protection, against short-circuit and blackout                  |
| <b>Operating temp.</b>                        | 0°C to +40°C   |
| <b>Storage temp.</b>                          | -20°C to +70°C   |
| <b>Humidity</b>                               | -20% to 80%RH (no condensation)  |
| <b>Accessories</b>                            | AC input cable 2.5m (1)<br>Instruction manual (1)  |

## Protections

### Over voltage protection (O.V.P)

DHOP series is equipped with over voltage protection, which protects load by limiting voltage up to approx. 110% of the rated output voltage even at abnormal conditions.

### Over current protection (O.C.P)

DHOP series is also equipped with over current protection, which protects power supplies and load by limiting current up to approx. 110% of the rated output current.

### High speed over current protection

DHOP series is provided with 2 types of over current protections, high speed over current protection to limit the pulse current, and standard over current protection to limit the static current.

The standard over current protection limits the static current, responding at around 1ms. Additional high speed over current protection can limit pulse current of square waveforms or from capacitor at approx. 2 times more current of rating.

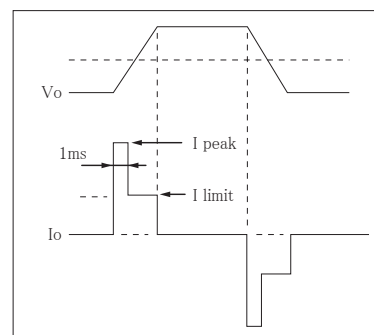

## Output range

DHOP series is a bi-polar power supply which can perform four-quadrant operation. They can supply (source) and absorb (sink) current in the field of the drawing on the right.

$V_o$  max : rated output voltage

$I_o$  max : rated output current

 Range of AC operation (with 50Hz or more frequency and 50 % of duty and without any DC bias)

 Range of DC operation

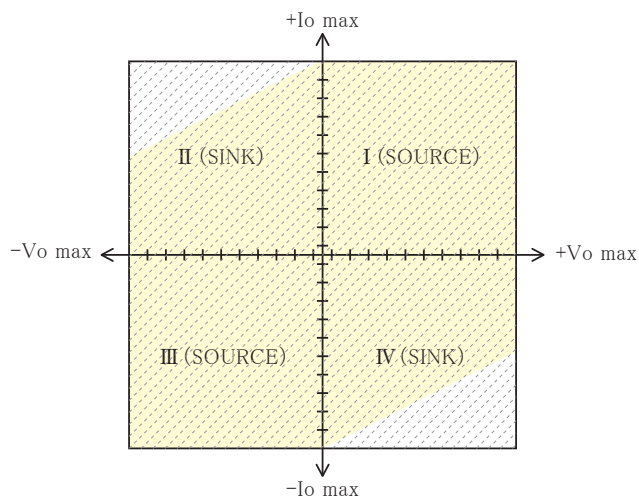

## Dimensions inch(mm) / Functions

### Front

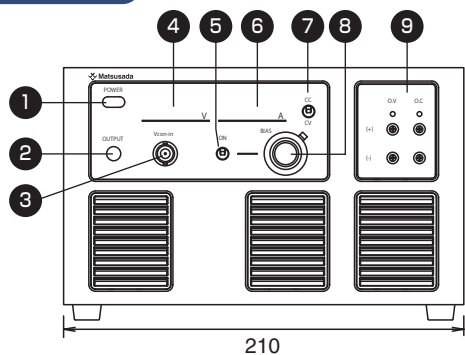

### Rear

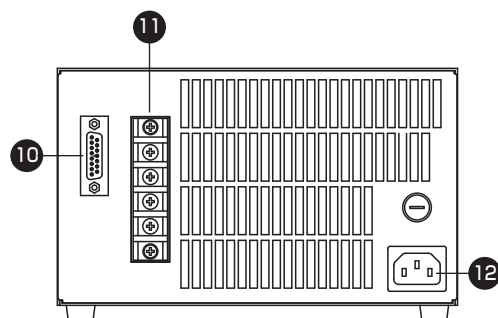

### Side

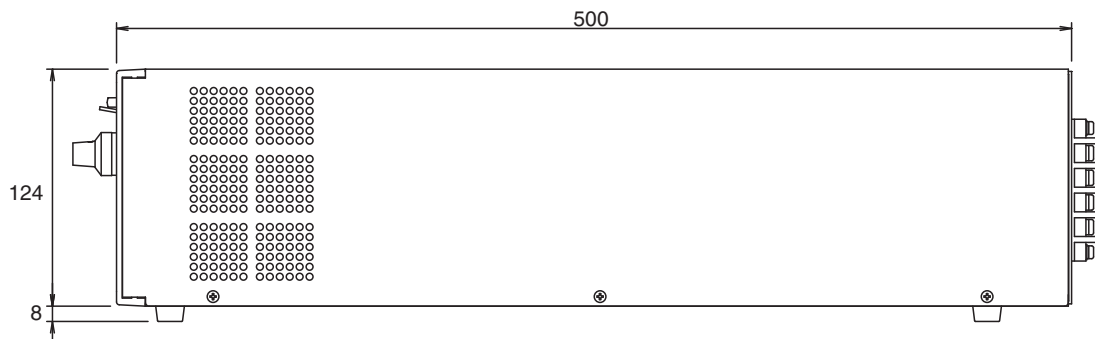

- |                          |   |
|--------------------------|---|
| ① POWER ON / OFF switch  | ⑦ CV / CC select switch                   |
| ② OUTPUT ON / OFF switch | ⑧ Bias setting dial                       |
| ③ Vcon-in terminal       | ⑨ Voltage / Current limitation setting VR |
| ④ Output voltage meter   | ⑩ Control connector                       |
| ⑤ Bias ON / OFF switch   | ⑪ Output terminal                         |
| ⑥ Output current meter   | ⑫ AC input terminal                       |

#### CV/CC setting selection

Inputting voltage via Vcon-in enables the control of output voltage V when CV control is selected and output current A when CC control is selected.

| Vcon | In CV mode     |                | In CC mode     |                |
|------|----------------|----------------|----------------|----------------|
|      | Output voltage | Output current | Output voltage | Output current |
| -10V | -Rating        | -Rating        | -Rating        | -Rating        |
| 0V   | 0V             | 0A             | 0V             | 0A             |
| +10V | +Rating        | +Rating        | +Rating        | +Rating        |

#### Use of BIAS

When the "BIAS ON/OFF switch" is flipped to ON, bias can be changed with the "BIAS setting dial." Bias of the voltage can be set when CV control is selected, and that of the current can be when CC control is selected.

| Scale    | In CV mode     |                | In CC mode     |                |
|----------|----------------|----------------|----------------|----------------|
|          | Output voltage | Output current | Output voltage | Output current |
| 000(ccw) | -Rating        | -Rating        | -Rating        | -Rating        |
| 500      | 0V             | 0A             | 0V             | 0A             |
| 1000(cw) | +Rating        | +Rating        | +Rating        | +Rating        |

## AC input cable

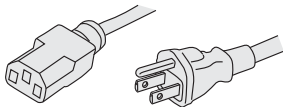
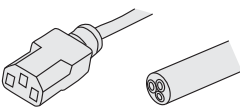
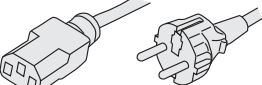
| <b>CABLE TYPE 1</b><br>125V / 10A<br>(Standard)                                   | <b>CABLE TYPE 3</b><br>250V / 10A<br>(Separately)                                 | <b>CABLE TYPE 4</b><br>250V / 10A<br>(Separately)                                  |
|---|---|--|
|  |  |  |

## Options

**-LD** Door switch ( Interlock )

**-LS** Remote switch ( Output ON / OFF )

When ordering, suffix the following option mark to the model number.

<e.g> DHOP45-5-LDS (Alphabetical order)

## Characteristic of amplifier

### Rise time

(Stepping time): The response time is sometimes described by the rise time (as shown in the drawing on the right).

The rise time of an amplifier at a response speed of (= frequency bandwidth)  $f_c$  (Hz) is generally acquired by " $t_r \doteq 0.35/f_c$ ."

Fall time  $t_f$  is the same as  $t_r$ .

Frequency bandwidth

: at 100kHz or lower,  $t_r = t_f =$  around  $3.5\mu s$

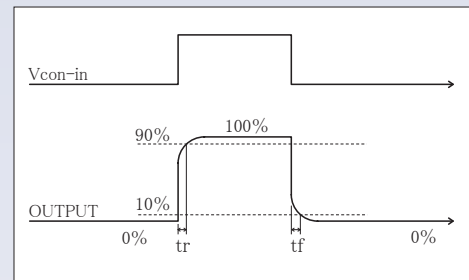

### Response speed

When accurate output waveforms are required, select an amplifier with a frequency bandwidth higher enough than the operating frequency.

In case of using sine waves, 3 to 5 times more frequency bandwidth is required, and around 10 times more in case of square waves in general. Inadequate bandwidth causes not only decrease in the output amplitude but much difference between the input and output phases. Therefore operating the product while monitoring the actual output waveforms is recommended.

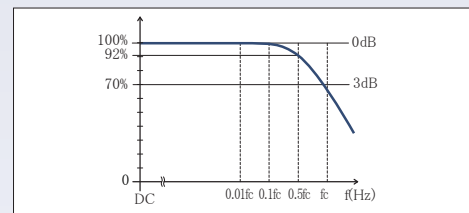

### Capacitive load

Capacitive load may cause oscillation.

In such cases, placed a power resistance in series with the output.

Be careful that the frequency bandwidth is limited depending on the resistance and capacitance placed in series when capacitive load.

### Inductive load

Some inductance of inductive load may cause resonance in CC mode.

In such cases, connect a C-R series circuit between output terminals to prevent resonance.

