

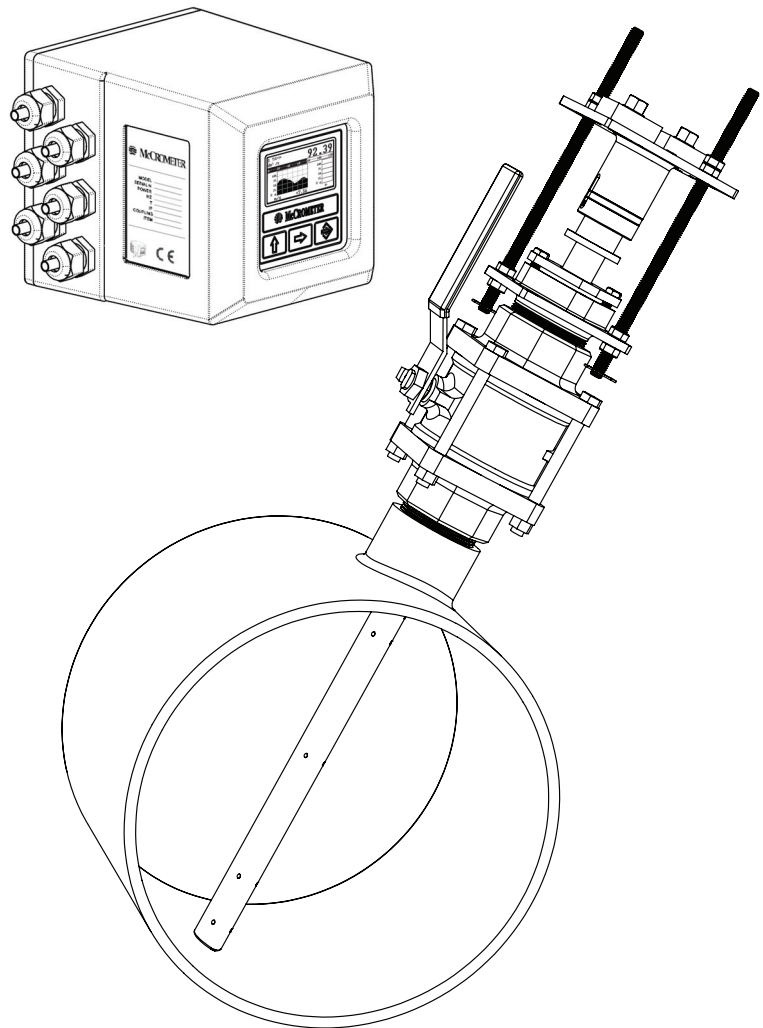

Insertable Electromagnetic L Series Averaging Magnetometer 2" and 3" Sensors Models 285L and 287L

Installation, Operation and
Maintenance Manual

24510-78 Rev. 1.5
October, 2009



CONTENTS

1.0 Safety Warnings	1
1.1 Safety Symbols And Warnings	1
1.2 Safety Warnings	1
2.0 Marsh Multi-Mag™ Models 285L & 287L	2
2.1 Instrument Overview.....	2
2.2 Principle Of Operation	3
3.0 Parts Diagrams	4
4.0 Installation	5
4.1 Site Selection.....	5
4.2 Sensor Clearance.....	5
4.3 Pipe Valve Installation	5
4.4 Meter Disassembly For Installation	6
4.5 Sensor Assembly Installation.....	6
4.6 Meter Re-assembly After Compression Seal Assembly Installation	7
4.7 Inserting The Sensor	7
4.8 Insertion Tool	9
4.9 Installing The Short Restraining Rods	9
5.0 Meter Removal	10
6.0 Electronics Installation	11
6.1 Mounting The Electronics Display	11
6.2 Cable Service Loop	12
6.3 Pulling Sensor Cable Through Electrical Conduit	12
6.4 Electrical Cable Connections.....	13
6.5 Terminal Board.....	13
6.6 Sensor Cable	13
6.7 4-20mA Hook-Up	14
6.8 Optional Dual 4-20mA Hook-up.....	14
6.9 Opto-Isolated Pulse Output Hook-Up	15
6.10 Dual Opto-Isolated Pulse Output Hook-Up.....	15
6.11 Converter Power Hook-up	16
7.0 Converter Start-Up	17
7.1 Menu Navigation.....	17
7.2 Front Panel Display	18
7.3 Factory Pre-Setting.....	19
7.3.1 Access Codes	19
7.3.2 Block Levels.....	19
7.4 "L" Series Menu Structure	20
8.0 Editing the Converter Settings	21
8.1 Quick Start Menu	21
8.2 Programming Example	24
9.0 Main Menu Descriptions	25
9.1.1 Menu 1-Sensor.....	25
9.1.2 Menu 2-Scales	25
9.1.3 Menu 3-Measures	26

9.1.4	Menu 4-Alarms	27
9.1.5	Menu 5-Inputs	27
9.1.6	Menu 6-Outputs	28
9.1.7	Menu 7-Communication	29
9.1.8	Menu 8-Display	30
9.1.9	Menu 9-Data Logger	30
9.1.10	Menu 10-Diagnostic	30
9.1.11	Menu 11-Internal Data	31
9.1.12	Menu 12-Batch	31
10.0	Alarm Messages	31
11.0	Maintenance	32
12.0	Specifications	33
13.0	Multi-Mag Ordering Information.....	35
13.1	The Standard Multi-Mag Includes.....	35
13.2	Options	35
13.3	Returning A Unit For Repair.....	35
Appendix		
App. 1.0	Commonly Used Converter Functions	36
App. 1.1	Zeroing The Totalizer	36
App. 1.2	Display Net Totalizer.....	36
App. 1.3	Turning Off Partial Totalizer.....	36
App. 1.4	Output Simulation.....	36
App. 2.0	"L" Series Menu Structure And Default Values	37
App. 3.0	Multi-Mag Specification Sheets.....	38-39
App. 4.0	Conversion Tables.....	40
	Table Of Decimal Equivalent.....	40
	Table Of Conversions	40
Warranty Statement.....		41

Copyright © 1997-2009 McCrometer, Inc. All printed material should not be changed or altered without permission of McCrometer. Any published technical data and instructions are subject to change without notice. Contact your McCrometer representative for current technical data and instructions. Marsh Multi-Mag™ is a trademark of McCrometer, Inc.



3255 WEST STETSON AVENUE • HEMET, CALIFORNIA 92545 USA
 TEL: 951-652-6811 • 800-220-2279 • FAX: 951-652-3078 Printed In The U.S.A.
 Lit. #24510-78 Rev. 1.5/10-09



1.0 Safety

1.1 Safety Symbols And Warnings

Throughout this manual are safety warning and caution information boxes. Each warning and caution box will be identified by a large symbol indicating the type of information contained in the box. The symbols are explained below:



This symbol indicates important safety information. Failure to follow the instructions can result in serious injury or death.



This symbol indicates important information. Failure to follow the instructions can result in permanent damage to the meter or installation site.

1.2 Safety Warnings

When installing, operating, and maintaining McCrometer equipment where hazards may be present, you must protect yourself by wearing Personal Protective Equipment (PPE) and be trained to enter confined spaces. Examples of confined spaces are manholes, pumping stations, pipelines, pits, septic tanks, sewage digesters, vaults, degreasers, storage tanks, boilers, and furnaces.

You must follow all state and local laws, as well as Occupational Health and Safety Administration (OSHA) regulations concerning Personal Protective Equipment, confined-space entry, and exposure to bloodborne pathogens. Specific requirements can be found in the OSHA section of the Code of Federal Regulations: *29 CFR, 1910.132 - 1910.140, Personal Protective Equipment; CFR Title 29, Part 1910.146, Permit-Required Confined-Spaces; and 29 CFR, 1910.1030, Bloodborne Pathogens.*



WARNING!

Incorrect installation or removal of Multi-Mag meters can result in serious injury or death.

Read the instructions in this manual on the proper procedures carefully.



WARNING!

Never enter a confined space without testing the air at the top, middle, and bottom of the space. The air may be toxic, oxygen deficient, or explosive. Do not trust your senses to determine if the air is safe. You cannot see or smell many toxic gases.



WARNING!

Never enter a confined space without the proper safety equipment. You may need a respirator, gas detector, tripod, lifeline, and other safety equipment.



WARNING!

Never enter a confined space without standby/rescue personnel within earshot. Standby/rescue personnel must know what action to take in case of an emergency.



WARNING!

Pressurized pipes should only be hot tapped, cut, or drilled by qualified personnel. If possible, depressurize and drain the pipe before attempting any installation.



WARNING!

Carefully read all safety warning tags attached to the meter.

2.0 Marsh Multi-Mag™ Models 285L & 287L

2.1 Instrument Overview

The Multi-Mag™ Models 285L and 287L flowmeters provide accurate flow measurement for full-pipe clean water applications. They are equipped with an innovative Multi-Mag™ sensor and a comprehensive electronics package.

The sensor is easily installed (without system shutdown), and requires no site calibration. The electromagnetic sensor uses multiple electrodes to measure average velocity directly and accurately.

The instrument has all of the features needed to suit a wide variety of applications, and is easily set up using the keypad and readouts.



Note: The converter and sensor are supplied as a matched system. Verify the system serial numbers on both the converter and sensor match. This will insure a properly calibrated system. The System Serial Numbers begin with MM20##### and are located on the side of the converter and on a tag near the end of the sensor cable.

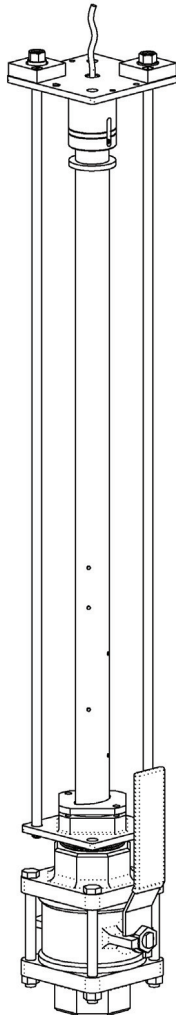

Figure 1: 2" 285L Sensor

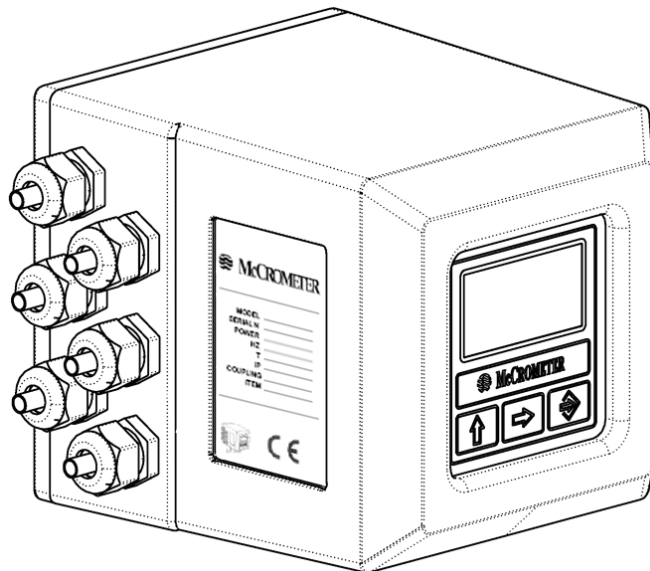

Figure 2: L Series Converter

The valve is optional or supplied by the customer, and is shown for illustration only.

2.2 Principle Of Operation

The Multi-Mag uses *Faraday's Law of Electromagnetic Induction* to measure water velocity. Faraday's Law states:

A conductor, moving through a magnetic field, produces a voltage.

Water is a conductor, so it produces a voltage when passing through a magnetic field. The magnitude of the voltage is directly proportional to the velocity at which the water moves through the magnetic field. Electromagnetic coils inside the sensor produce magnetic fields, and electrodes on the sensor's surface measure the voltage generated by the moving water.

The electrode pairs are located so that each measures an equal cross-sectional area, see Figure 3. The velocity measurements are averaged together, providing an area-weighted average velocity across the pipe centerline. Flow is calculated by multiplying the average velocity by the cross-sectional area of the pipe.

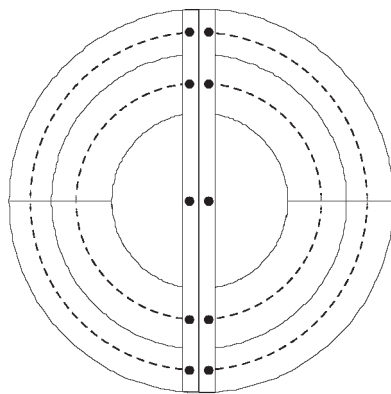

Figure 3: Pipe cross-section (with sensor in center) Each electrode pair measures an equal area of the cross-section

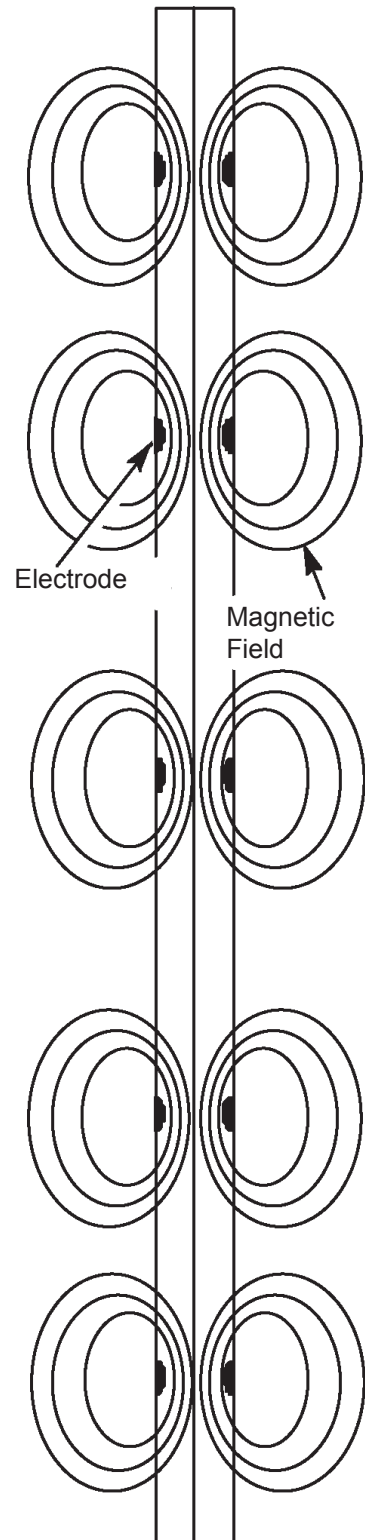
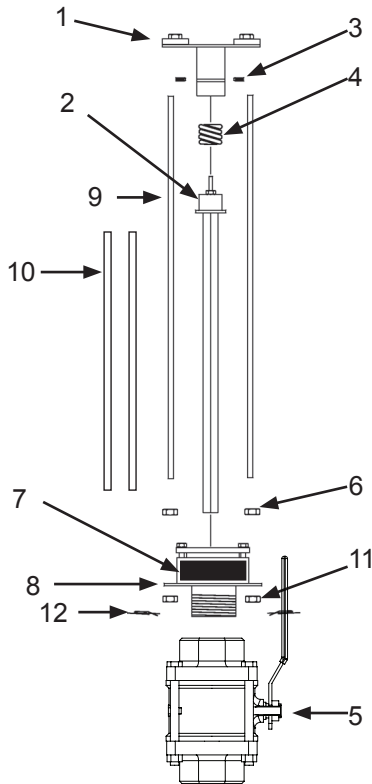
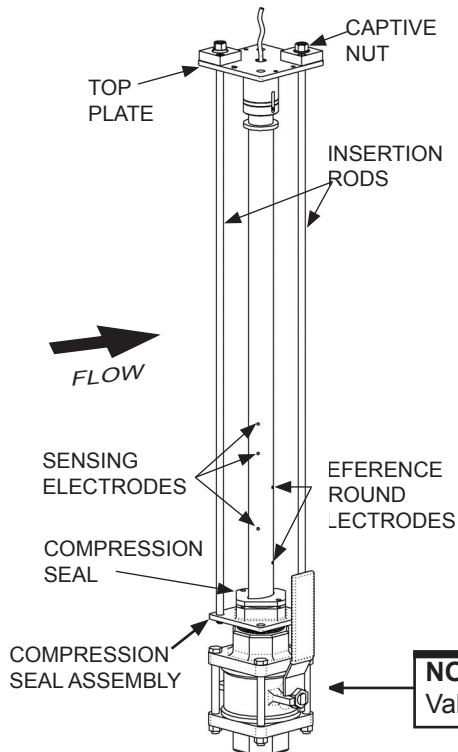

Figure 4: Multi-Mag sensor (with electrodes)

3.0 Parts Diagrams



Part Name And P/N	
1	Top Plate 2" Top Plate 3"
2	Sensor Assembly 2" 60000xxxx Sensor Assembly 3" 600005xx-L
3	Set screw (2 ea.) 920001001
4	Spring 2" & 3" 920000902
5	Ball Valve 2" Bronze 43055 / SS 43059 Ball Valve 3" Bronze 43055-3/ SS 43059-3
5	Corporation Stop 2" Corporation Stop 3"
6	Nipple SS 2" 43060 Nipple SS 3" 43064
7	Compression Seal 2" 520002201 Compression Seal 3" 520005000
8	Compression Seal Assembly 2" 800005801 Compression Seal Assembly 3" contact factory
9	3/8" SS Long Threaded Rods (2 ea.) 64006
10	3/8" SS Short Threaded Rods (2 ea.) 422003801
11	3/8" SS Nut (4 ea.) 93007
12	Locking Cotter Pin 921000701



285 L Multi-Mag sensor assembly (2" Sensor)

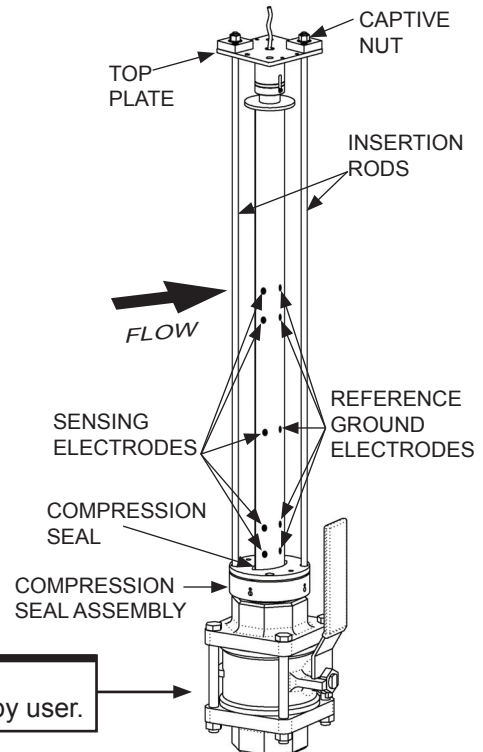

287 L Multi-Mag sensor assembly (3" Sensor)

NOTE
Valves are optional or supplied by user.

Figure 5: Parts Diagrams



4.0 Installation

Please read the following information before installing the Multi-Mag sensor.

4.1 Site Selection

Install the sensor at an adequate distance from flow disturbers such as elbows, T-junctions, Y-junctions, and active valves. Whenever possible, install the sensor upstream from a bend or junction. While the Multi-Mag is very flexible regarding its placement, for problematic installations please contact your local McCrometer representative for a site specific placement recommendation.

4.2 Sensor Clearance

The sensor will protrude from the pipe when installed demanding sufficient clearance (distance H, in Figure 6 below) from any obstruction. This distance accounts for the length of the sensor, the distance from the outer pipe wall to the top of the valve plus 9" (229 mm). See App. 3.0 Submittal Sheets located in the Appendix for the proper calculations for clearance distance.

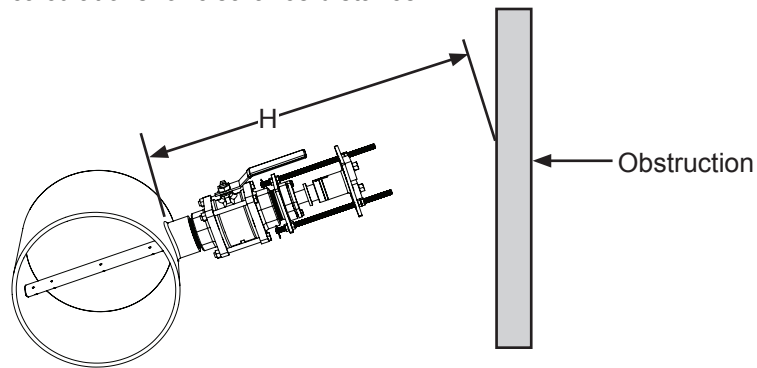

Figure 6: Sensor Clearance distance

4.3 Pipe Valve Installation



WARNING!

Pressurized pipes should only be hot tapped, cut, or drilled by qualified personnel using high quality saddles, valves and stainless steel nipples. If possible, depressurize the pipe before attempting any installation.

Install a 2" (50mm) full port valve or corporation stop with a 2" (50mm) NPT female pipe thread output for the 2" sensor, or a 3" (75mm) full port valve or corporation stop with a 3" (75mm) NPT female pipe thread output for the 3" sensor. Follow any and all installation instructions provided for the valve that you have chosen. The valve or corporation stop can be installed onto a welded coupling or pipe saddle. See Figure 7.

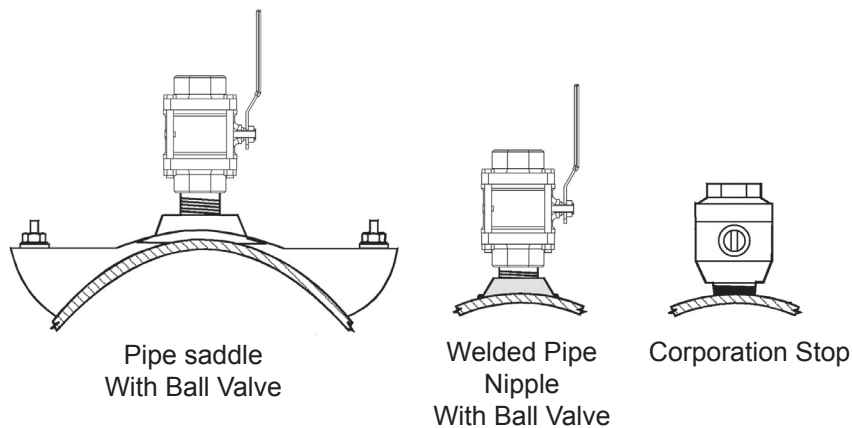

Figure 7: Installation Valve Options

4.4 Meter Disassembly For Installation

When installing large meters, it can be desirable to remove the compression seal assembly from the rest of the meter and install it onto the valve separately. The following steps describe the separation of the sensor, top-plate and retaining rods from the compression seal assembly.

4.4.1 Loosen the bolts on the compression seal relieving the pressure on the compression seal. Do not remove the bolts.

4.4.2 On the compression seal assembly, remove the locking cotter pins from the bottom of the two retaining rods under the 3/8" nuts.

4.4.3 Remove the 3/8" nuts from the retaining rods.

4.4.4 Slide the sensor out of the compression seal. The retaining rods will also slide out of the compression seal assembly. Carefully set the sensor and attached hardware to the side.

4.4.5 At this point the compression seal assembly can be installed onto the valve.

4.5 Sensor Assembly Installation

The sensor assembly uses a compression seal, which keeps the sensor watertight when the pipe is under pressure. Care must be taken when installing the sensor, to avoid leaks.

4.5.1 Visually inspect all elements of the installation to insure they are structurally sound and of high quality materials, including all welds, couplings and nipples. To prevent future corrosion, nipples should be high quality stainless steel.

4.5.2 Put a generous amount of the pipe sealant (supplied with the sensor) on the compression seal threads. (Teflon tape may also be used.) NOTE: if pipe sealant gets on the sensor electrodes the velocity signal may be lost.

4.5.3 Place the compression seal threads over the pipe valve. Turn the entire sensor assembly clockwise to secure the assembly to the valve.

4.5.4 The seal is secure when a large amount of force is required to turn the assembly. Line up the arrow (on the top plate) with the direction of the flow. The sides of the bottom plate should be parallel with the pipe.

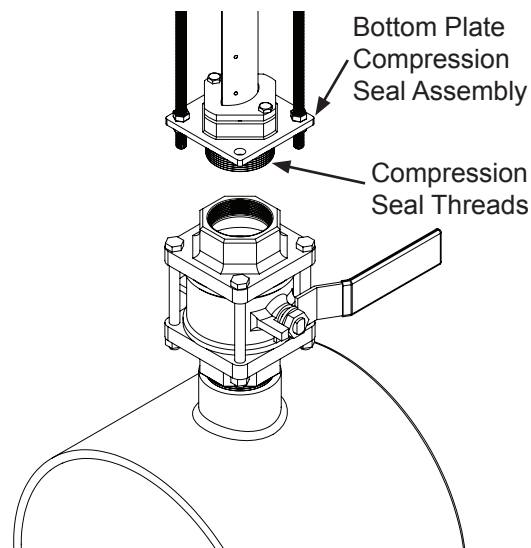

Figure 8: Sensor Installation

4.6 Meter Re-assembly After Compression Seal Assembly Installation

1. Insert the sensor into the compression seal in the bottom plate while inserting the two retaining rods into their respective holes in the bottom plate and secure with 3/8" nuts. Insure the two nuts above and below the compression seal assembly are sufficiently tightened to prevent the threaded rod from rotating.
2. Insert the locking cotter pins through the small holes in the bottom of the restraining rods, just below the 3/8" nuts.

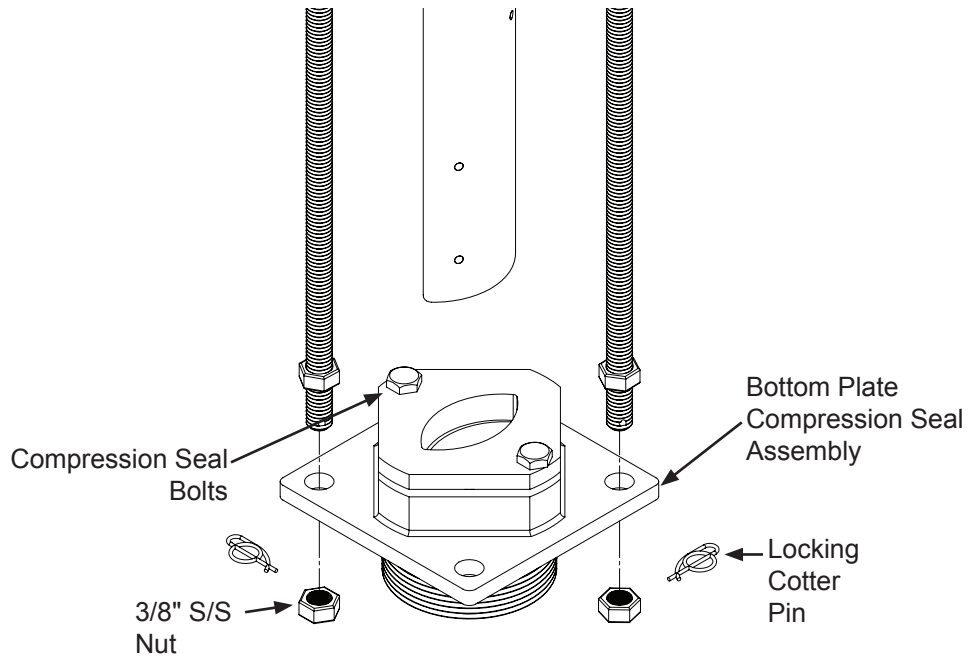

Figure 9: Compression Seal Assembly

4.7 Inserting The Sensor

The sensor can be installed while the line is under flowing conditions. The line water velocity should be as low as possible to prevent sensor vibration during the insertion process. The velocity must be under 5 ft./sec.

WARNING!

The compression seal/sensor assembly may be under pressure. Serious injury may result if proper procedures are not followed. Do not attempt to install the sensor without the restraining rods fully assembled.

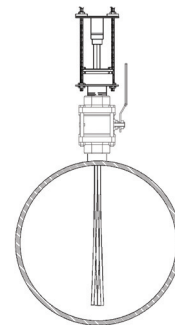

Figure 10: Sensor vibration

If the meter was disassembled to assist in the installation of the compression seal assembly on to the valve (Section 4.6) it is important to insure that the meter is properly reassembled with both retaining rods completely installed with the 3/8" nuts properly tightened and the locking cotter pins inserted.

4.7.1 Insure the two compression seal bolts are hand tightened.

4.7.2 Barely crack open the valve and tighten compression seal bolts as required to minimize leaks. A towel draped around the compression seal can reduce spray if necessary.

4.7.3 Open the valve completely. Failure to open the valve completely will cause the valve to scrape the sensor during insertions and may result in permanent damage to the sensor.

4.7.4 Insert the sensor into the pipe by simultaneously rotating the two captive nuts on the top plate clockwise with the two ratchet wrenches provided until the foot of the sensor reaches the far wall of the pipe and the load spring is compress. See Section 4.7.5. It is recommended that the sensor insertion tool (p/n 75031) be used to rotate the captive nuts to insure the top plate compresses evenly. See Section 4.8.



IMPORTANT

If the captive nuts are not tightened simultaneously, the top plate will become crooked and cause the sensor to be inserted at an angle and may cause permanent damage to the sensor.

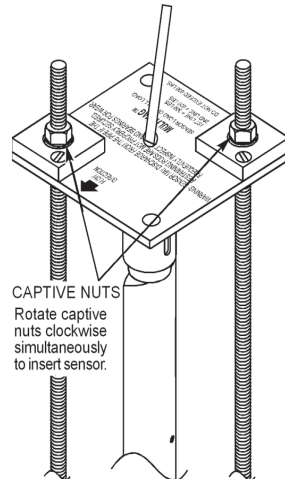

Figure 11: Captive Nuts



NOTE

If the short restraining rods are not used (see Section 4.11), run a 3/8" nut down against each captive nut to prevent the captive nut from rotating.

4.7.5 A load is now applied at the top of the sensor forcing the bottom of the sensor to seat against the far wall. This keeps the sensor firmly in place against the far wall of the pipe. The amount of load is indicated by the two lines and set screw at the top of the sensor. See Figure 12. The bottom line indicates a 300-lb. load.

Recommended sensor loads are 300 lbs. or less for plastic pipes and 450 lbs. for metal pipes.

4.7.6 Rotate the two captive nuts on the top plate until the proper load is indicated. If using the Insertion Tool, rotate the two captive nuts using only the **low** gear shaft until the proper load is indicated. **DO NOT** use the high gears on the insertion tool as this may create too much load too fast and damage the sensor or the pipe.

4.7.7 Tighten the compression seal bolts again. The bolts should be tightened only until there is no leaking.

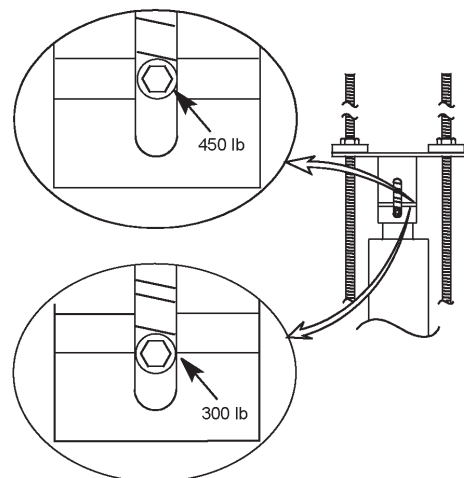

Figure 12: Sensor Load Indicators

4.8 Sensor Insertion Tool

McCrometer recommends using a sensor insertion tool (P/N 75031) to help with inserting the sensor and to avoid any damage to the sensor. Place the profiling insertion tool over the captive nuts and lock it into place with spring locks located on the bottom of the tool. Using the provided wrench rotate the high gear shaft clockwise until the bottom of the sensor reaches the far wall of the pipe. The low gear shaft is used to apply pressure to the sensor once the sensor has reached the far wall of the pipe. See Section 4.7.5.

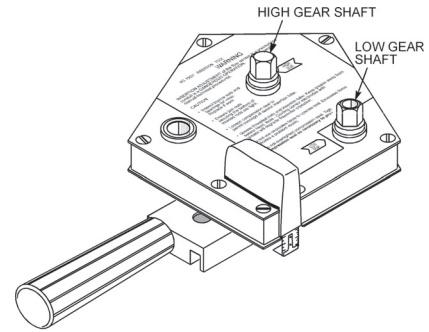

Figure 13: Insertion Tool

4.9 Installing The Short Restraining Rods

After the sensor has been inserted and the load adjusted, shorter restraining rods can be installed and the longer ones removed. This will make the sensor assembly more compact.



IMPORTANT

The long restraining rods are matched to each sensor and are required for removal of the sensor. It is important to safely store the long restraining rods and label them with the meter serial number.

- 4.11.1. Secure the short restraining rods to the bottom plate with two 3/8" nuts and a locking cotter pin per rod. Install one of the 3/8" nuts above the bottom plate, and one below the bottom plate. See Figure 14.
- 4.11.2. Secure the short restraining rods to the top plate with one 3/8" nut per rod.
- 4.11.3. Remove the long restraining rods.
- 4.11.4. Check and adjust the "Sensor Load" as necessary. See section 4.9.5.
- 4.11.5. Secure the 3/8" nuts on the top plate by running a second jam nut down and tightening it against the first nut.

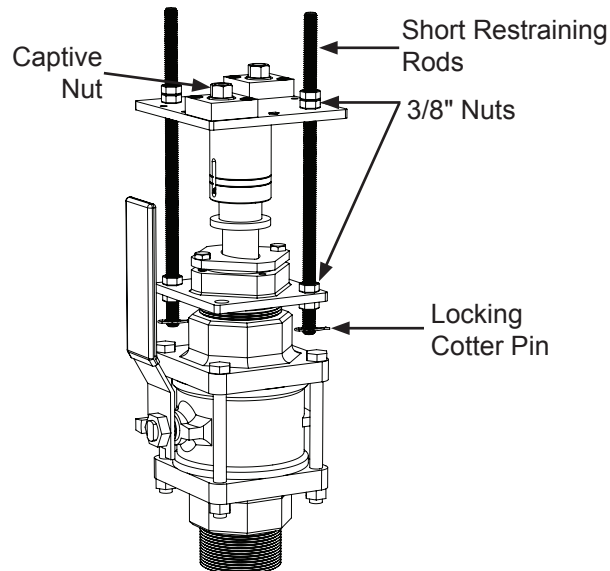

Figure 14: Short Restraining Rods Installation

5.0 Meter Removal



WARNING!

The pipe may be under pressure. Serious injury or death may result if proper procedures are not followed. Do not attempt to remove the short restraining rods without the long restraining rods properly installed. Do not attempt to remove the sensor with the short restraining rods.

To remove the meter follow the steps below.

5.1 Visually inspect the pipe and entire assemble for damage or corrosion paying close attention to any nipples and welded couplings. If there is any doubt as to the condition of any element of the pipe or meter, depressurize the line before attempting a removal of the meter.

5.2 Reduce line velocity to 5 ft/sec to prevent sensor vibration.

5.3 Thread a long restraining rod through the captive nut until the rod nears the bottom plate. Make sure that the bottom of the rod has the hole for the locking cotter pin.



IMPORTANT

Use the long restraining rods provided with the meter. If the restraining rods shorter than those provided by the factory will not allow the sensor to be removed.

5.4 Thread a 3/8" nut onto the bottom of the long restraining rod about an inch up from the bottom of the rod.

5.5 Continue rotating the long restraining rod until the bottom of the rod passes through the holes on the bottom plate.

5.6 Thread another 3/8" nut onto the bottom of the long restraining rod until it is flush with the bottom plate. Tighten the nuts above and below the bottom plate securely locking the long restraining rod in place. Attach the locking cotter pin into the hole through the bottom of the long restraining rod.

5.7 Repeat the process for the second long restraining rod.

5.8 Once both of the long restraining rods are securely in place, completely remove the short restraining rods.

5.9 Loosen the compression seal bolts until the seal just begins to leak. This will relieve the pressure on the compression seal allowing the sensor to be removed. Draping a towel around the compression seal can reduce any spraying water. NOTE: The compression seal may prevent immediate leakage on sensors installed for a long period of time until the sensor begins to rise.

5.10 Rotate the captive nuts on the top plate simultaneously. the sensor insertion tool is recommended. See Section 4.8. This will cause the sensor to rise out of the pipe. If the line is under pressure do not remove the sensor from the compression seal completely. Only raise the sensor until it is clear of the valve, but still below the compression seal. Once the sensor has cleared the valve mechanism, the valve can then be closed. Do not attempt to force the valve closed while the sensor is still passing through the valve as permanent damage to the sensor can occur.

5.11 Once the valve is closed, the entire sensor can be removed from the valve.

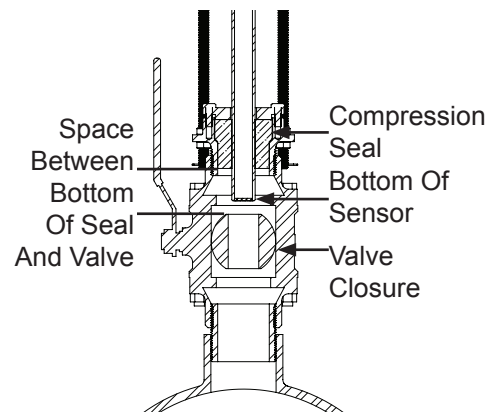

Figure 15: Cross-Section Of Meter Showing Sensor Removal

6.0 Electronics Installation

6.1 Mounting The Electronic Display

If possible mount the electronic unit in an electronics shed or environmental enclosure. If the unit is mounted outdoors a sun shield is recommended with the unit oriented in a direction to reduce sun damage and ensure readability. The converter is mounted using 2 bolts. See Figure 16. A service loop in the cables is required. See Section 6.2. This electronic unit is not suitable for installations subject to flooding.

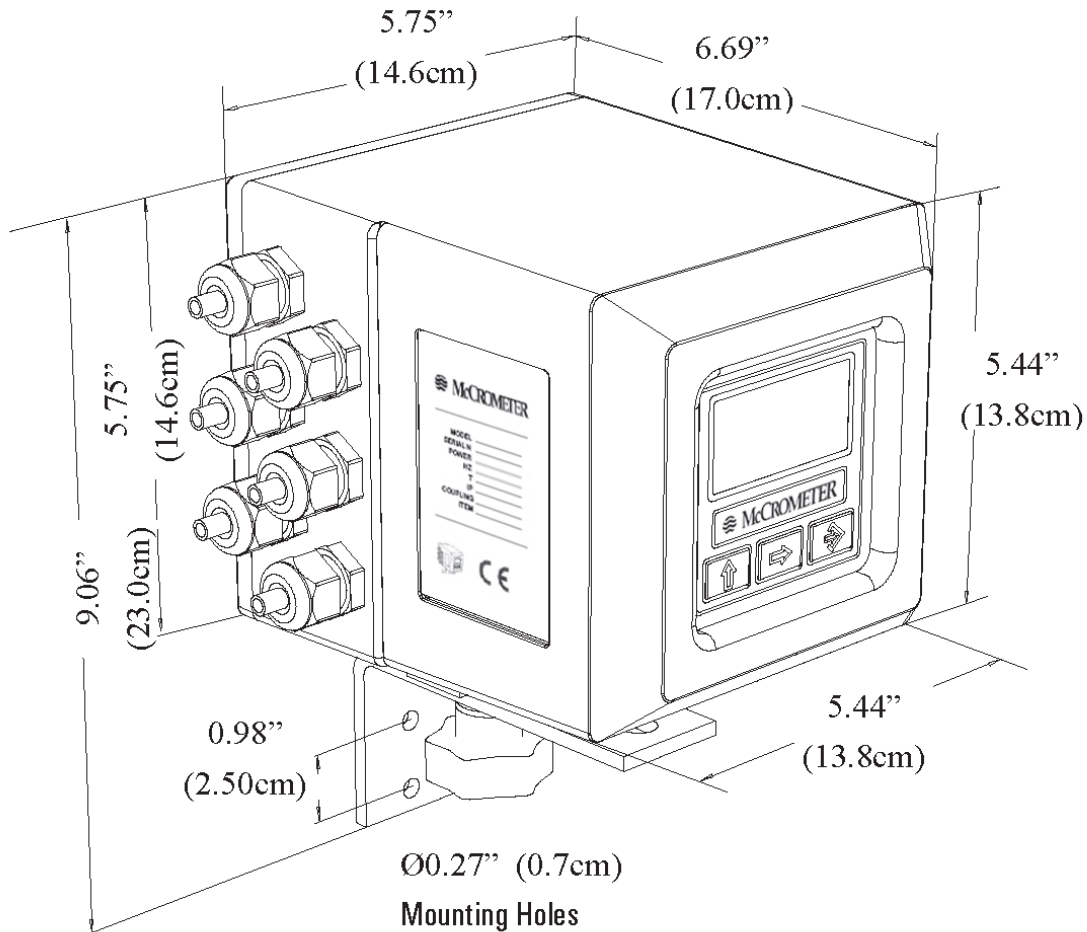

Figure 16: Electronic Converter Dimensions

6.2 Cable Service Loop

Rigid conduit cannot be attached directly to the L Series electronics enclosure. Any cable running through a rigid conduit must exit the rigid conduit and have a minimum of an 8" service loop before entering the electronics enclosure through the cable glands. This allows the electronics enclosure to be rotated and the rear panel to be accessed. See Figure 8. To insure IP67 rating use only round cable 0.125" to 0.375" in diameter.



Caution: Do not connect any form of conduit directly to the converter enclosure. Doing so will allow moisture and potentially dangerous gasses directly into the electrical compartment of the converter.

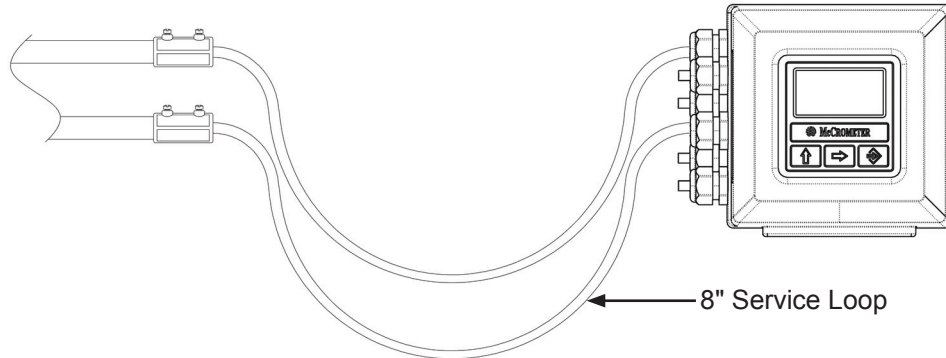

Figure 17: Cable Service Loop

6.3 Pulling Sensor Cable Through Electrical Conduit

It is very important to protect the end of the sensor cable when pulling it through a conduit. Water can accumulate in low portions of conduit. Always use the factory supplied cable plug, or similar method, to seal the end of the cable against water when pulling the cable through conduit. See Figure 18. This will insure proper operation of the meter.

Pulling The Sensor Cable:

1. Tie a rope or cable-snake securely around the middle of the cable plug.
2. Carefully pull the rope or snake until the sensor cable end clears the conduit.
3. Bring the cable end to the converter location. If necessary, secure the cable so that it does not fall back through the conduit.
4. Remove the cable plug by pulling the rip-wire. The cable plug will tear off (discard the plug).



Caution: Do not cut the cable cover off. Doing so may damage the sensor cable and adversely effect the calibration of the meter.

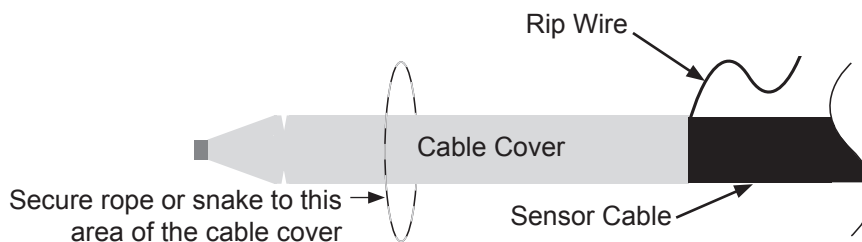

Figure 18: Cable Cover

6.4 Electrical Cable Connections



CAUTION

Always disconnect the AC power cord before attempting any electrical connections.

All electrical cables enter the unit through compression fittings located on the side of the converter. Ensure that all unused fittings are plugged so the case remains sealed.

6.5 Terminal Board

All connections are made on the terminal board. To access the terminal board, loosen the four screws on the back of the converter to remove the rear cover.

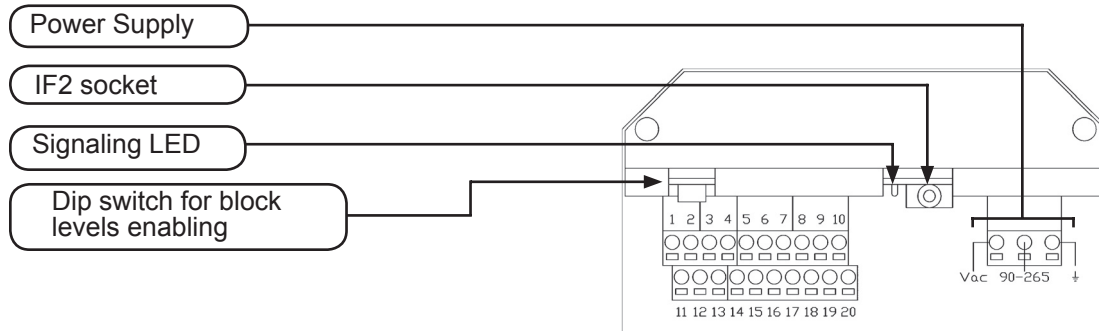

Figure 19: Terminal Board Descriptions

6.6 Sensor Cable

The terminals for the sensor cable connection are numbers 1, 2, 3, 11, 12 and 13 on Terminal Block M1. Connect the sensor cable wires using the color code table below. NOTE: the terminal blocks unplug from the circuit board for easy connection.

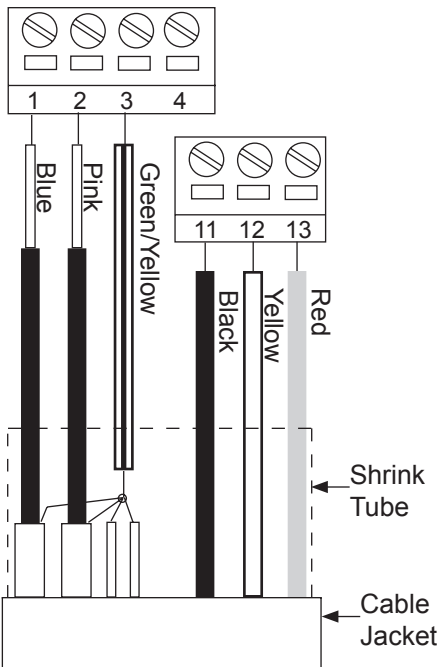

Figure 21: Sensor Cable Connections

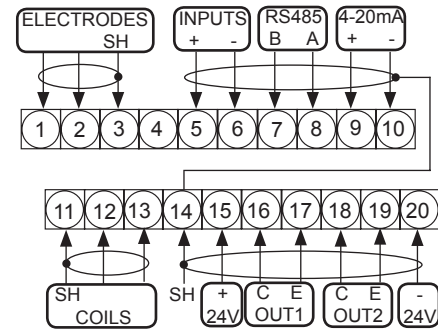

Figure 20: Terminal Block M1 Assignments

Terminal	Wire Color	Connected To
#1	Blue	Right sensing electrodes
#2	Pink	Left sensing electrodes
#3	Green/Yellow	Ground electrodes Combination of: Purple, green/yellow and drain wires from sensing electrode cables
#11	Black	Magnet shield / overall cable shield
#12	Yellow	Coil
#13	Red	Coil

6.7 4-20mA Hook-Up

Isolated 4-20mA current loops are used to output flow data to external devices. Maximum load impedance is 1,000Ω, and the maximum voltage without load is 27VDC. The converter has the capability to detect a loss of load on this output. To disable this function set the value “mA Val. Fault” (Section: Main Menu, Sec.. 4.7) under the ALARMS menu to zero. A graphical example of the usage of the current loop with external device is shown below:

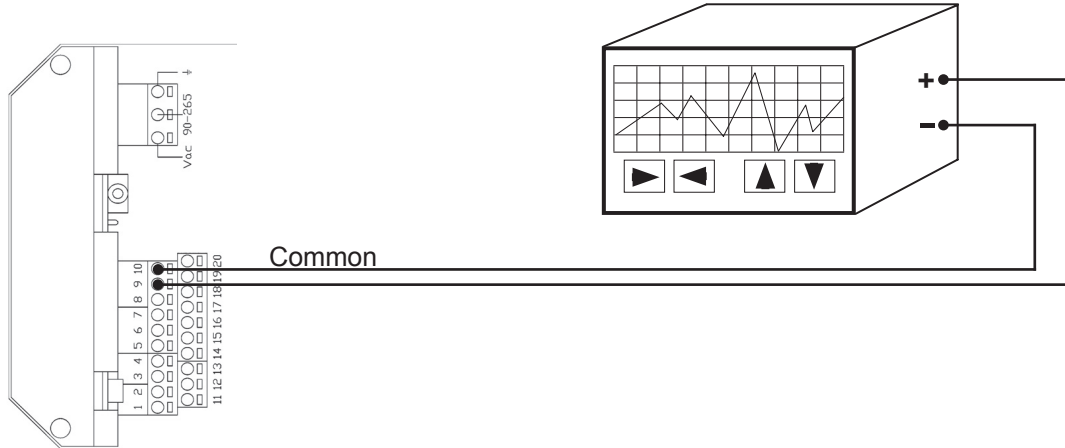

Figure 22: 4-20mA Hook-Up

If the external device requires a voltage input, a precision resistor placed across the input terminals of the external device will change the current to voltage. Calculate the required resistor using Ohm's law ($V = I \times R$). For example, a 250Ω resistor will provide an input voltage of one to five volts with the transmitter range being set from 4mA to 20mA. An additional 4 to 20mA loop output is available

6.8 Optional 4-20mA Hook-Up

Converters with the optional dual 4-20mA output will have an additional terminal block located to right of the M1 terminal block. Wiring hook up is as shown in Figure 23 below.

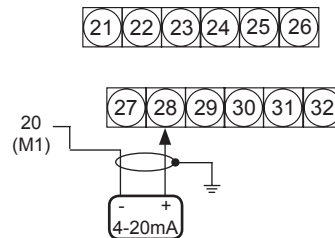

Figure 23: Optional Dual 4-20mA Hook-Up

6.9 Opto-Isolated Pulse Output Hook-Up

The two pulse outputs are transistor outputs used to activate external devices when the flow reaches a predetermined set point.

- Opto-isolated output with collector and emitter terminals floating and freely connectable
- Maximum switching voltage: 40 VDC
- Maximum switching current: 100mA
- Maximum saturation voltage between collector and emitter @100mA: 1.2V
- Maximum switching frequency (load on the collector or emitter, $R_L=470\Omega$, $V_{OUT}=24VDC$): 1250Hz
- Maximum reverse current bearable on the input during an accidental polarity reversion (VEC): 100mA
- Insulation from other secondary circuits: 500 V

A common application of a relay (pulse) output should be connected as follows:

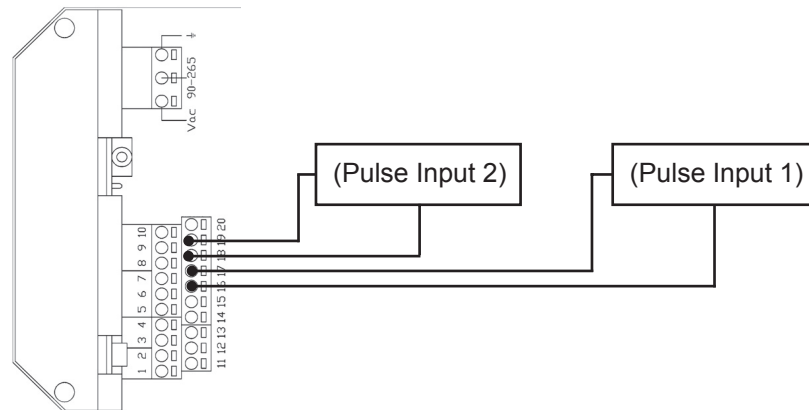

Figure 24: Opto-Isolated Pulse Output Diagram

6.9 Dual Opto-isolated Pulse Output Hook-up

A typical application of two isolated pulse outputs is provided below:

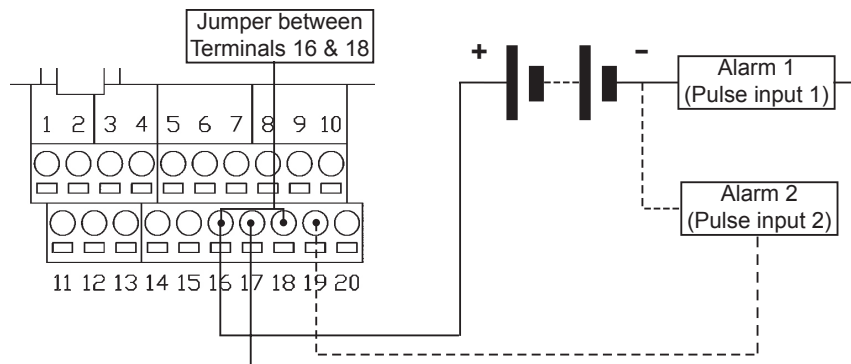

Figure 25: Pulse output hook-up with external power supply

NOTE: Pulse outputs can be used without external power supplies. Terminals 15 and 20 should be used to properly connect internal power supply to the scheme shown above. Please consult the factory with any questions. Please consult the table in Section "Menu 6-Outputs" for all the possible applications for the two outputs.

6.11 Converter Power Hook-Up



WARNING!! Hazardous supply voltage can shock, burn, or cause death.

The power supply line must be equipped with external surge protection for current overload (fuse or circuit breaker with limiting capacity not greater than 10A). It must be easily accessible for the operator and clearly identified.

Power connection is made using the power terminal block on the upper right side of the terminal board. NOTE: the terminal block unplugs from the circuit board for easy connection. Connect earth ground to the protective grounding terminal before making other connections. The power supply of a standard converter is 90-265VAC, 44-60Hz at maximum 20W. DC converter is available as an option.

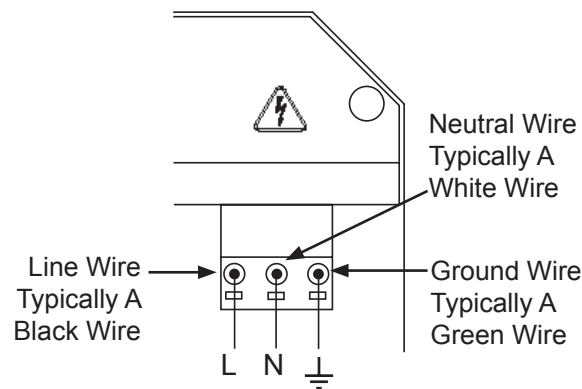

Figure 26: Power Supply Terminal Block

7.0 Converter Start-Up

Before starting up the converter please verify the following:

- Power supply voltage must correspond to that specified on the name plate
- Electric connections must be wired as described in this manual
- Ground connections must be properly installed

When the instrument is powered and exhibits different operating conditions than those at the last shutdown, it initiates a verification cycle of the converter. During the verification cycle the converter displays an incrementing diagnostic number from 0 through 90. When the diagnostic is complete an error number will be displayed referencing the chart at the back of this manual. A text message will also be displayed on the alarm screen (to view alarms, press the UP arrow key from the main display screen).

7.1 Menu Navigation

To navigate through the menus on the converter, the keys on the keypad use the following conventions:

Key:

Function:

UP ARROW KEY (for moving cursor up or down)

SHORT PRESSING (< 1 SECOND):



It moves the cursor up to the previous subject on the menu
It increases the numeric figure of the parameter highlighted by the cursor
Batch start/stop (when enabled)

LONG PRESSING (> 1 SECOND):



It moves the cursor down to the next subject on the menu
It decreases the numeric figure of the parameter highlighted by the cursor

RIGHT ARROW KEY (for moving cursor right or left)

SHORT PRESSING (< 1 SECOND):



It moves the cursor to the right on the input field
It moves the cursor to the following subject of the menu
It changes the display of the process data

LONG PRESSING (> 1 SECOND):



It moves the cursor to the left on the input field
It moves the cursor to the previous subject on the menu

RIGHT COMMAND KEY (for changing settings)

SHORT PRESSING (< 1 SECOND):



It opens the main menu for the instrument configuration
It enters/leaves the selected function
It cancels the selected function under progress

LONG PRESSING (> 1 SECOND):



It confirms the selected function
It leaves the current menu
It enables the totalizer reset request (when enabled)

7.2 Front Panel Display

Short-press the right-arrow key to view different display screen.

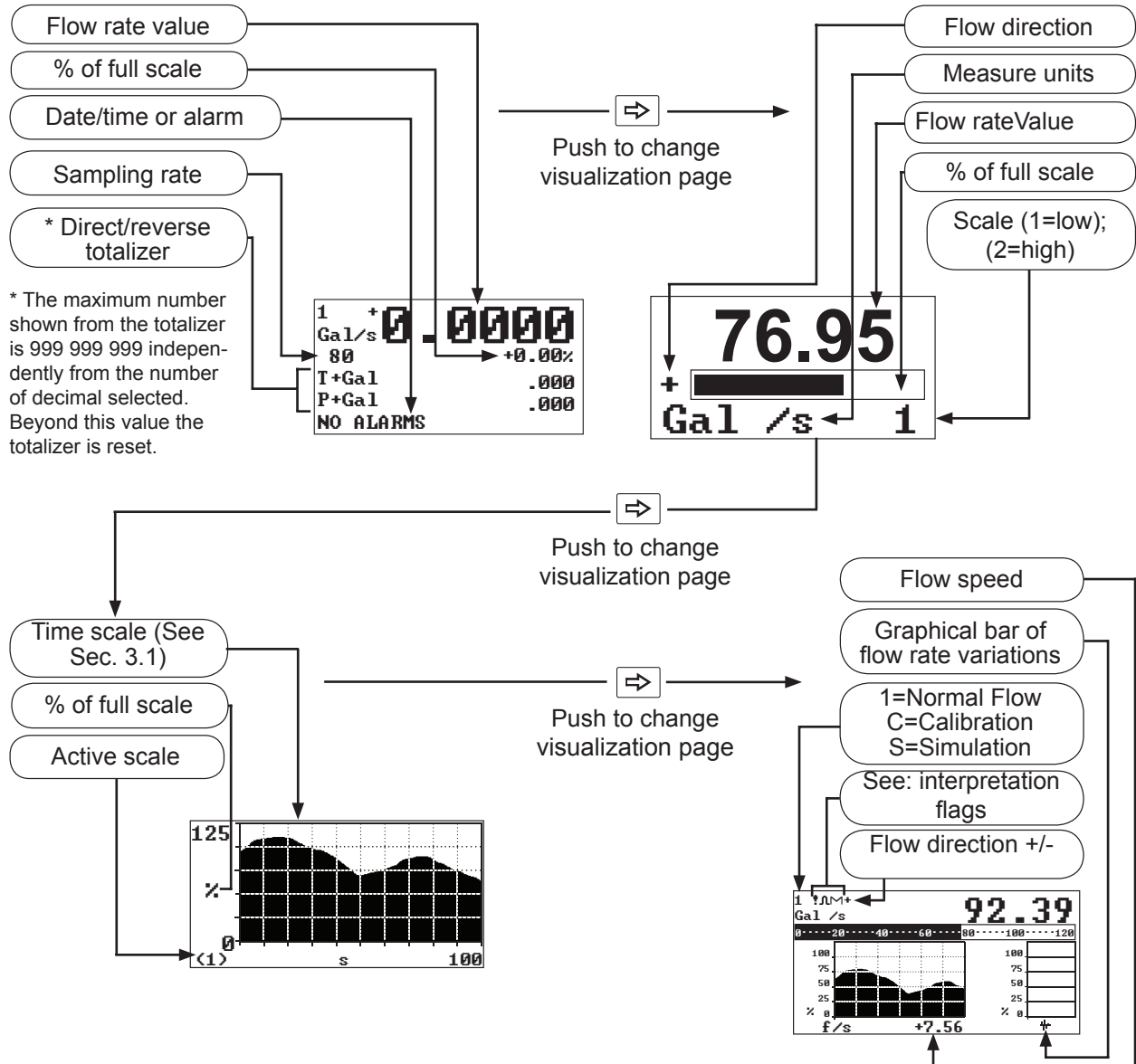

INTERPRETATION FLAGS	
FLAGS	DESCRIPTION
M	Alarm max activated
m	Alarm min activated
!	-Interruption coils circuit -Signal error -Empty pipe
∩	Pulse output saturation (reduce TIME PULSE)

NOTE: Visualization of the pages can be changed depending on whether some functions are enabled or disabled.

7.3 Factory Pre-Setting

7.3.1 Access Codes

The converter is delivered with access code L2 (Menu “11-Internal data” Section 11.1) = **00002**, and with the “Quick start menu” enabled. Press the key  to access the “Quick start menu”, and the functions within can be set without entering any access code. The “Quick start menu” is enabled from the section: Menu “8-Display”, section 8.6.

With access code L2 = 00000, the request of the code is disabled. With access code L2 customized*, one can proceed with programming all functions up to L2 security level by entering the code itself whenever the access to the Main menu is required.



***ATTENTION!**

It is very important to record the customized code as it **CANNOT** be retrieved if it is lost!

7.3.2 Block Levels

The block level enables or disables the access to the functions of the converter. The available levels of block are as described below (Section: Menu “11-Internal data” Section 11.2):

- Level 0: it completely disables the access to the main functions. The following functions can be performed through the keyboard:
 - Changing the display mode
 - Performing start/stop
 - Data printing
- Level 1: it enables the access to the following functions:
 - Totalizer resetting
- Level 2: it enables the access to the following functions:
 - Quick start menu
 - Scale (fully enabled)
 - Display (partially enabled)
 - Diagnostics (partially enabled)

7.4 "L" Series Menu Structure

The following is the menu structure for the "L" Series converter. NOTE: Some menus change as options are enabled.

0. Quick Start

Fs1=
 Tot. MU=
 Pls1=
 Tpls1=
 T Const=
 ND =
 Simulation=
 Contrast
 Language
 Batching Setup
 Regulat. Setup
 Flow meas. Setup
 Main menu

1. Sensor

ND=
 KA=
 Sens. type =
 KL=
 KL=
 Cable Len =
 E.p. Detect=
 AutoZero Cal.
 E.P. calibr.

2. Scale

FS1=
 Tot.MU=
 Pls1=
 Tpls1-ms
 Mass units=

3. Measure

T-Const=
 Filter=
 Skip thr=
 Peak thr=
 Cut-off=
 Autocal.=
 Autorange=
 E.saving=

4. Alarm

Max thr+=
 Max thr-=
 Min thr+=
 Min thr-=
 Hyst.=
 E.p. thr.=
 mA v.fault=

5. Inputs

T + RESET=
 P + RESET=
 T - RESET=
 P - RESET=
 Puls reset=
 Count lock=
 Calibration=
 Range change=
 Batch=

6. Outputs

Out1=
 Out2=
 Duty Cycle1=
 Out. mA1=

7. Communication

IF2 Prot.=
 Address=
 RS485 bps=
 A. delay=
 Rem. addr=
 Remote u. conn.

8. Display

Language=
 D. rate=
 Contr. range=
 Contrast=
 P. totaliz=
 Date/time=
 Quick start=
 Tot. modif=
 Net total=
 Reset Video=
 Currency=

9. Data Logger

(Date/time)
 Acquisition=
 Display events
 Clear events

10. Diagnostic



Calibration
 Self Test
 Simulation=

11. Internal data

L2 keycode=
 Load fact. pres.
 Load user pres.
 Save user pres.
 Ign. cal. err=
 KS=

8.0 Editing The Converter Settings

8.1 Quick Start Menu

In certain situations it may be necessary to edit the factory pre-set converter settings. In such a case this chapter explains the conventions used. Press the keys  or  to toggle between the “Quick start menu” and the visualization pages. Follow the steps of the flow chart below to change the parameters in this menu.

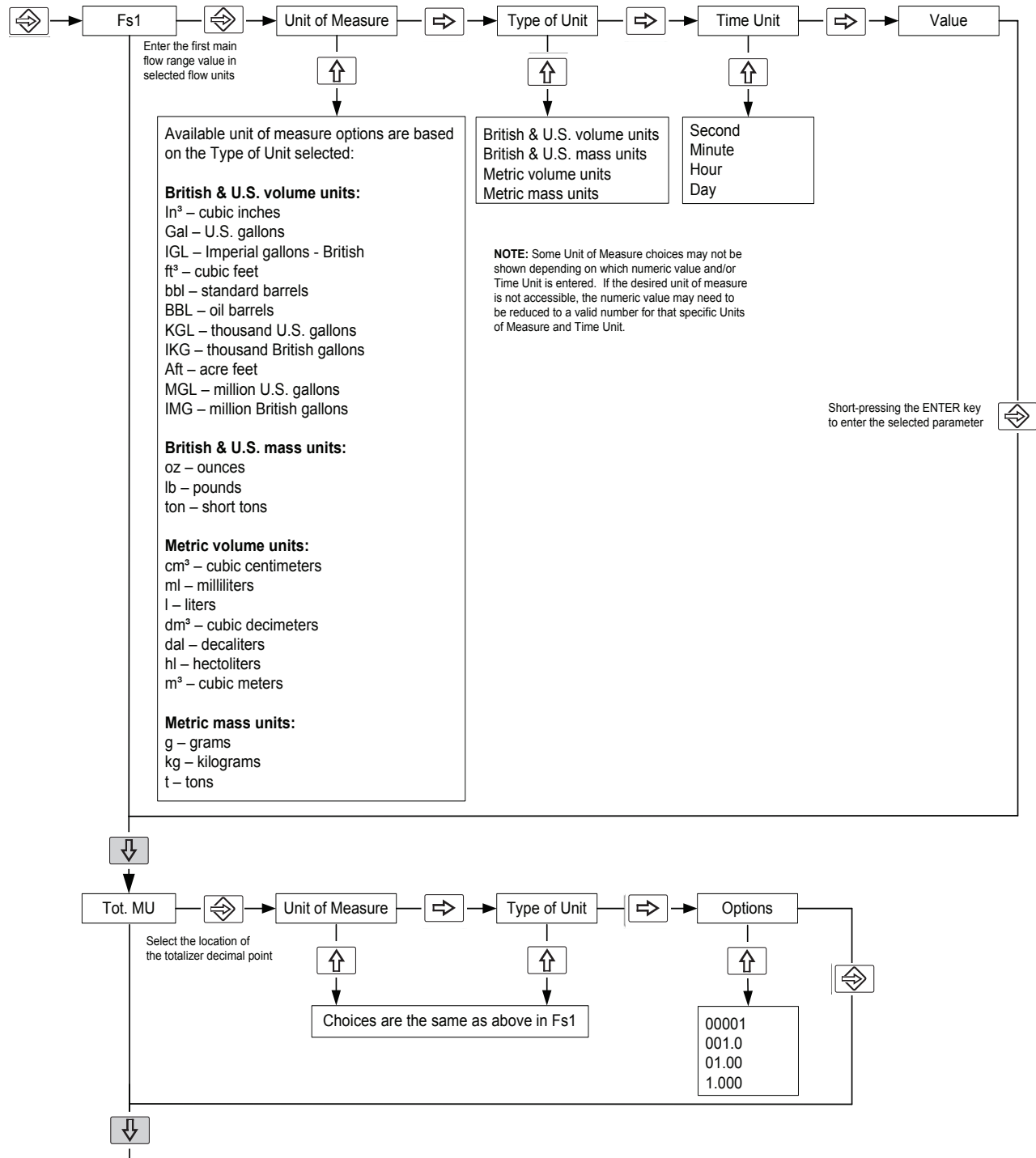

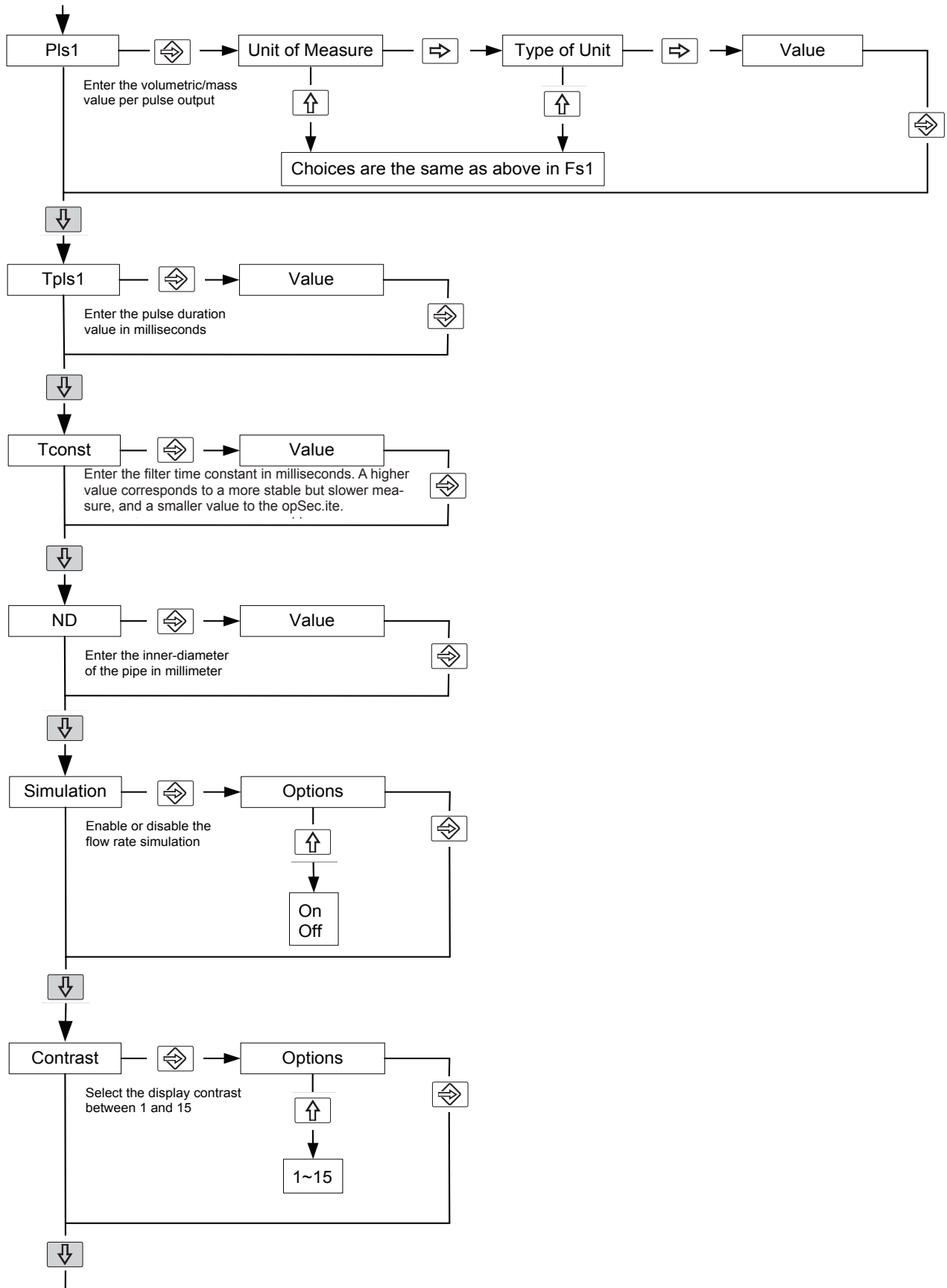

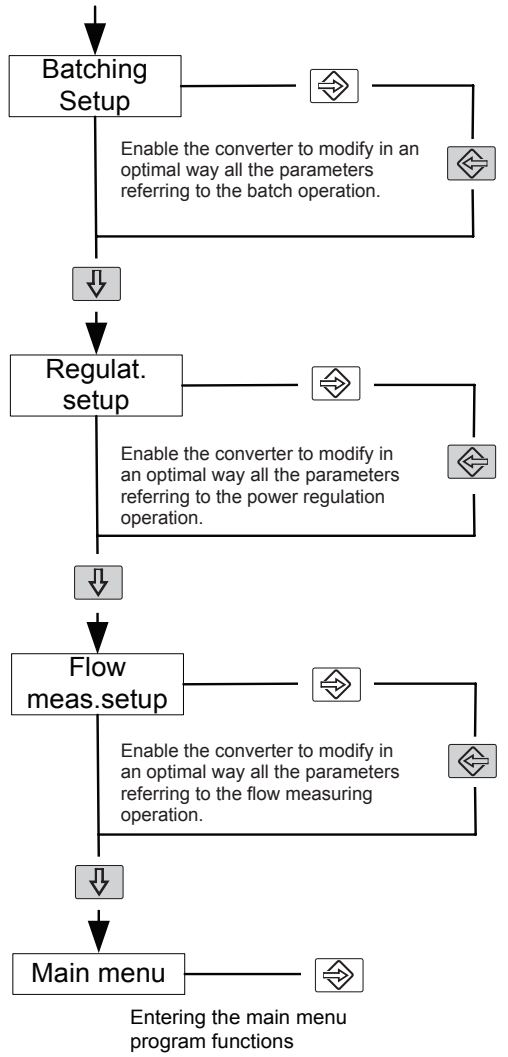

8.2 Programming Example

The steps below demonstrate how to modify the full scale value from 4dm³/s to 5dm³/s from the "Quick start menu".

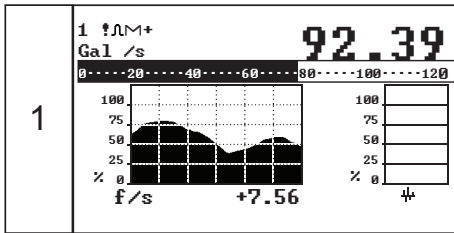

Enter the "Quick Start Menu"

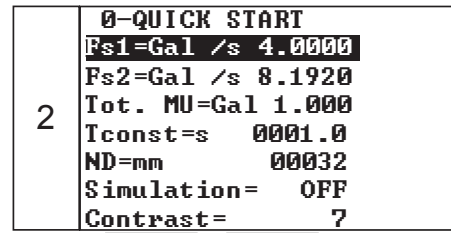

Access the function "Fs1"

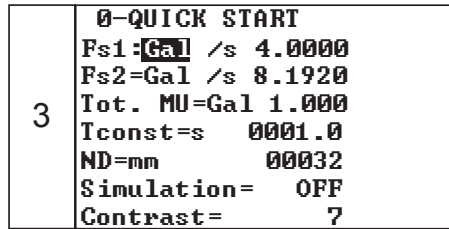

Push Repeatedly

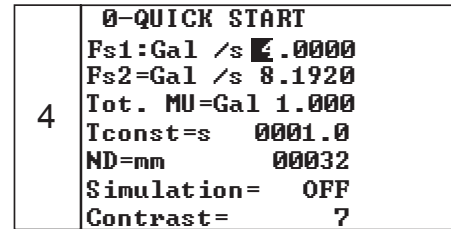

Change the value

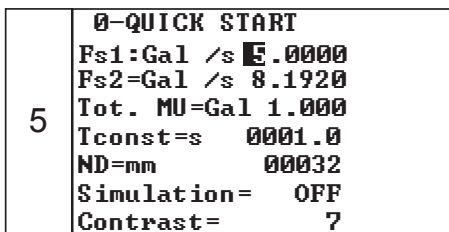

Confirm the new value with a short press

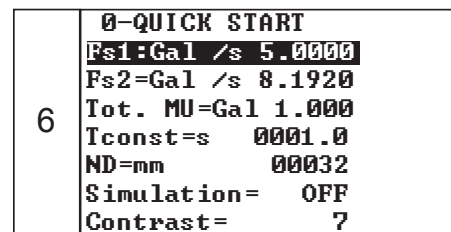

Long push to exit to the main page

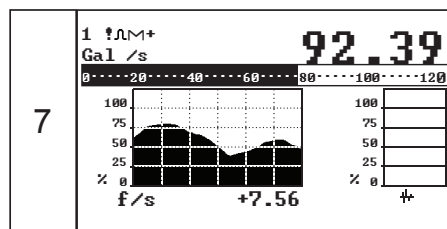

Main visualization page

Figure 27: Programming Example Screens

9.0 Main Menu Descriptions

Press the key  to go to the Main menu directly when the “Quick start menu” is disabled. When it is not disabled you can select the Main menu from the “Quick start menu”. The functions in the Main menu are explained below. Please note that some functions are only displayed if other functions are enabled or with the insertion of additional modules

9.1.1 Menu 1-Sensor

Sec. 1.1 ND: inner-diameter of the pipe in millimeters

Sec. 1.2 KA: factory-set gain factor

Sec. 1.3 Sens.type: 3 digit user defined ID number.



Sec. 1.4 KL+[0-5]: factory-set linearization points for forward flow



Sec. 1.5 KL-[0-5]: factory-set linearization points for reverse flow

NOTE: In order to input the negative values of KL+ and KL-, the value should be input prior to changing the sign form “+” to “-”.

Sec. 1.6 Cable len.: cable length in multiples of 10 meters

Sec. 1.7 E.P.detect: empty pipe detection enable or disable

Sec. 1.8 Autozero cal.: automatic zero calibration system execution. To perform this function you must fill the pipe with liquid that is perfectly still. Even very small amounts of movement of the liquid may affect the result of this function. When the percentage flow rate value is stable at zero, press the  key. Check that the percentage flow rate value goes to zero, otherwise repeat the operation again. When the value is stable at zero, then press the  key to complete this calibration.

Sec. 1.9 E.P.calibr.: enabling of the automatic calibration of the empty pipe detection. Before performing this function, the pipe has to be completely filled with the liquid. The pipe has then to be emptied again, and then you should press the  key. The operation will have to be confirmed by pressing the  key. With this function, the system sets the value of the empty pipe detection threshold (Section: Menu: 4-Alarms - Sec. 4.6 “E.p.thr.”). NOTE: Do not perform this procedure without first contacting the factory.

```

1-SENSOR
ND=mm      00032
KA=        +01.0080
Sens.type= 000
KL=+[0]    +02.1500
KL=-[0]    +02.1500
Cable len.=m 000
E.P.detect= OFF
Autozero cal.
E.P. calibr.
    
```

Figure 28: Menu 1 Sensor

9.1.2 Menu 2-Scales

Sec. 2.1 Fs1: full scale flow range

Sec. 2.2 Fs2: second full scale flow range. This function appears when the Sec. 3.7 “Aurorange” in the menu “3-Measure” is enabled.

Sec. 2.3 Tot.MU: location of the totalizer decimal point

Sec. 2.4 Pls1: amount of volume or mass per pulse for output channel 1.

Sec. 2.5 Pls2: amount of volume or mass per pulse for output channel 2. This function appears when Sec. 6.2 “Out2” in the menu “6-Outputs” is selected to have a pulse output on output channel 2.

Sec. 2.6 Tpls1: pulse duration generated on output channel 1.

Sec. 2.7 Tpls2: pulse duration generated on output channel 2. This function appears when Sec. 6.2 “Out2” in the menu “6-Outputs” is selected to have a pulse output on output channel 2.

```

2-SCALES
Fs1=Gal /s 5.0000
Fs2=Gal /s 8.1920
Tot.MU=Gal 1.000
Pls1= Gal 1.00000
Pls2= Gal 1.00000
Tpls1=ms 0050.00
Tpls2=ms 0050.00
Frq1=Hz 1000.00
Frq2=Hz 1000.00
Mass units= ON
Sg=kg/Gal 01.0000
    
```

Figure 29: Menu 2 Scales

Sec. 2.8 Frq1: full scale frequency (0.1Hz~1000.0Hz) for output channel 1. This function appears when Sec. 6.1 “Out1” in the menu “6-Outputs” is selected to have a frequency output on output channel 1.

Sec. 2.9 Frq2: full scale frequency (0.1Hz~1000.0Hz) for output channel 2. This function appears when Sec. 6.2 “Out2” in the menu “6-Outputs” is selected to have a frequency output on output channel 2.

Sec. 2.10 Mass units: enabling/disabling of the selection of mass units on full scale set

Sec. 2.11 Sg: specific gravity set in kg/dm³. This function appears when a mass unit of measure is selected for the full scale.

9.1.3 Menu 3-Measures



CAUTION! All parameters in this menu are set at the factory for the optimal performance of the meter. Modifying any value without proper reasoning, and/or contacting McCrometer’s Technical Support, may decrease the meter’s performance.

Sec. 3.1 Tconst: measuring time constant in seconds (Default = 4s).

Sec. 3.2 Filter: filter on the power supply in seconds. 0.1s = “ready” measure and 0.5s = filter of noise on the liquid (Default = 0.1s).

Sec. 3.3 Skip thr: acceleration threshold in percentage of full scale. The acceleration threshold stands for the limit beyond which a flow rate variation determines an immediate response at the output, without being filtered by the time constant (Default = 25%).

3-MEASURE	
Tconst=s	0001.0
Filter=s	0.1
Skip thr=%	010
Peak thr=%	125
Cut-off=%	05.0
Autocal.=	OFF
Autorange=	OFF
E.saving=	OFF

Sec. 3.4 Peak thr: anomalous signal peak cut off threshold in percentage of full scale. This parameter allows setting the maximum value of deviation of the actual measure sample by comparison with the average one. If the new value is higher than the set limit, then such a value is “cut” to the limit value. This function is used to make the meter less sensitive to big perturbations on the flow rate measure, as it may happen when there are solids in suspension in the liquid hitting against the electrodes which then detect high electrical noise (Default = 125%).

Figure 30: Menu 3 Measure

Sec. 3.5 Cut-off: flow velocity in percentage of full scale below which all outputs are set to zero (Default = 2%).

Sec. 3.6 Autocal.: enabling/disabling of an internal calibration cycle every hour. If selected, measurement is stopped for 8~15 seconds.

Sec. 3.7 Autorange: enabling/disabling automatic change of scale. When the flow rate increases and reaches the 100% of the full scale 1, then the meter automatically switches to scale 2. When the flow rate decreases again reaching a value on scale 2 equal to the 90% of full scale 1, then the active scale is 1 again.

Sec. 3.8 E.saving: enabling/disabling of energy saving mode. It is recommended to use this function only when the instrument is powered by a battery or solar cells, allowing an energy savings to 80%. This function enables the automatic control of the energy consumption by changing the ratio between the measuring cycles powering the coils and the cycles without powering the coils. When the flowrate is stable, the number of “off” cycles is higher than the “on” ones, so that the average consumption is strongly reduced. If the flowrate suddenly changes, then the meter switches on a higher number of measuring cycles to get a higher response time. The system switches off the cycles as soon as the flowrate becomes stable.

9.1.4 Menu 4-Alarms

Sec. 4.1 Max thr+: maximum value alarm set in percentage of full scale for forward flowrate.

Sec. 4.2 Max thr-: maximum value alarm set in percentage of full scale for reverse flow rate.

Sec. 4.3 Min thr+: minimum value alarm set in percentage of full scale for forward flow rate.

Sec. 4.4 Min thr-: minimum value alarm set in percentage of full scale for reverse flow rate.

Sec. 4.5 Hyst.: hysteresis threshold set for the minimum and maximum flow rate alarms in percentage of full scale.

Sec. 4.6 E.p.thr.: factory-set empty pipe detection threshold. It is obtained by performing an empty pipe calibration.

Sec. 4.7 mA v.fault: current output value set in percentage indicating failure. Allowed range is from 0 to 120% of the 0..20 mA scale, 120% corresponds to 24 mA and does not depend on the selected range (0...20 / 4...20 mA). The default value is set at 10%, so that the current value in case of the a.m. cases would be 2 mA, allowing the following diagnostics:

- current < 2 mA - 5%: line interrupted, power supply failure or faulty converter;
- 2 mA -5% < current < 2 mA + 5%: hardware alarm;
- 4 mA < current < 20 mA: normal working range;
- 20 mA < current < 22 mA: out of range, measure above 100% of the full scale

4-ALARMS	
Max thr+=%	000
Max thr-=%	000
Min thr+=%	000
Min thr-=%	000
Hyst. =%	03
E.p. thr.-	075
mA v.fault=%	000

Figure 31: Menu 4 Alarms

9.1.5 Menu 5-Inputs

Sec. 5.1 T+ RESET: enabling/disabling of the forward flow totalizer reset.

Sec. 5.2 P+ RESET: enabling/disabling of the partial forward flow totalizer reset.

Sec. 5.3 T- RESET: enabling/disabling of the reverse flow totalizer reset.

Sec. 5.4 P- RESET: enabling/disabling of the partial reverse flow totalizer reset.

Sec. 5.5 Puls.reset: enabling/disabling of the pulse output totalizer reset from the digital input.

Sec. 5.6 Count lock: enabling/disabling of blocking the totalizer count from the digital input.

Sec. 5.7 Calibration: enabling/disabling of performing automatic calibration from the digital input. When this function is active, after applying the voltage to the on/off input terminals, the meter performs an autozero calibration cycle. ATTENTION: if the voltage pulse is less than 1 sec., the meter performs a calibration cycle for compensating possible thermal drifts. If the voltage pulse is more than 1 sec, the meter performs a zero calibration of measure.

5-INPUTS	
T+ RESET =	ON
P+ RESET =	ON
T- RESET =	OFF
P- RESET =	ON
Puls.reset =	ON
Count lock =	ON
Calibration =	OFF
Range change =	OFF
Batch =	OFF
Inp. 2 =	OFF

Figure 32: Menu 5 Inputs

Sec. 5.8 Range change: enabling/disabling of changing the full scale range from the digital input.

Sec. 5.9 Batch: enabling/disabling of batching start/stop from the digital input.

Sec. 5.10 Inp.2: functions assigned to input 2. This function only appears when the optional input module is installed.

9.1.6 Menu 6-Outputs

Sec. 6.1 Out1: output 1 function assignment.

Sec. 6.2 Out2: output 2 function assignment.

Sec. 6.3 Out3: This function only appears when the optional output module is installed.

```

6-OUTPUTS
Out1=    #1 IMP+
Out2=           SIGN
Out3=           OFF
Out4=    #2 IMP+
Duty cycle=%  50
Out mA1=4÷22
Out mA2=4÷22
    
```

Figure 33: Menu 6 Outputs

Sec. 6.4 Out4: This function only appears when the optional output module is installed.

Sec. 6.5 Duty cycle1: duty cycle value for pulses/frequency output on output 1. This function only appears when the output 1 is assigned to have either a pulse or a frequency output.

Sec. 6.6 Out mA1: range of current output 1 and choices of the function.

Sec. 6.7 Out mA2: range of current output 2 and choices of the function. This function only appears when the additional 4-20mA module is installed.

Functions corresponding to the outputs are listed in the table below.

Function Symbol	Function Explanation
#1 IMP+	Pulse on output 1 for forward flow rate
#1 IMP-	Pulse on output 1 for reverse flow rate
#1 IMP	Pulse on output 1 for forward and reverse flow rate
#2 IMP +	Pulse on output 2 for forward flow rate
#2 IMP -	Pulse on output 2 for reverse flow rate
#2 IMP	Pulse on output 2 for forward and reverse flow rate
#1 FREQ+	Frequency on output 1 for forward flow
#1 FREQ-	Frequency on output 1 for reverse flow
#1 FREQ	Frequency on output 1 for forward and reverse flow
#2 FREQ+	Frequency on output 2 for forward flow
#2 FREQ-	Frequency on output 2 for reverse flow
#2 FREQ	Frequency on output 2 for forward and reverse flow.
SIGN	Flow direction output (energized = reverse flow)
RANGE	Range indication output (energized = full scale 2)
MAX AL+	Max. forward flow rate output (energized = alarm off)
MAX AL-	Max. reverse flow rate output (energized = alarm off)
MAX AL	Max. forward and reverse flow rate output (energized = alarm off)
MIN AL+	Min. forward flow rate output (energized = alarm off)
MIN AL-	Min. reverse flow rate output (energized = alarm off)

MIN AL	Min. forward and reverse flow rate output (energized = alarm off)
MAX+MIN	Max. and min. flow rate alarm output (energized = alarm off)
EMPTY PIPE	Empty pipe alarm output (energized = alarm off)
OVERFLOW	Out of range alarm output (energized = flow rate is in range)
Hardw AL.	Cumulative alarm output; interrupt coils, empty pipe, and/or measure error (energized = alarms off)
EXT. COMM.	Communication alarm. Only available with data logger module (energized = alarm off)

CURRENT VALUES IN mA ASSOCIATED TO THE % VALUE OF FULL SCALE					
POSSIBLE FIELD	REVERSE FLOW VALUE		ZERO	DIRECT FLOW VALUE	
	≤ - 110%	-100%	0%	+100%	≥+110%
OutmA= 0 ÷ 20 +	0	0	0	20	20
OutmA= 0 ÷ 22 +	0	0	0	20	20
OutmA= 4 ÷ 20 +	4	4	4	20	20
OutmA= 4 ÷ 22 +	4	4	4	20	20
OutmA= 0 ÷ 20 -	20	20	0	0	0
OutmA= 0 ÷ 22 -	22	20	0	0	0
OutmA= 4 ÷ 20 -	20	20	4	4	4
OutmA= 4 ÷ 22 -	22	20	4	4	4
OutmA= 0 ÷ 20	20	20	0	20	20
OutmA= 0 ÷ 22	22	20	0	20	22
OutmA= 4 ÷ 20	20	20	4	20	20
OutmA= 4 ÷ 22	22	20	4	20	22
OutmA= 0 ÷ 20 —0+	0	0	10	20	20
OutmA= 0 ÷ 22 —0+	0	1	11	21	22
OutmA= 4 ÷ 20 —0+	4	4	12	20	20
OutmA= 4 ÷ 22 —0+	4	4.8	12.8	20.8	22

9.1.7 Menu 7-Communication

These menu functions are not supported.

9.1.8 Menu 8-Display

Sec. 8.1 Language: language choice: E = English, I = Italian, F = French, S = Spanish.

Sec. 8.2 D.rate: updating frequency of the display (choices of 1, 2, 5, and 10 Hz).

Sec. 8.3 Contrast: display contrast. This value can also be set from one of the display visualization pages by pushing the  key for 8 seconds or more. In this way, the contrast set will be visualized at release of the key. NOTE: Do not attempt this function without contacting McCrometer's Technical Support.

Sec. 8.4 P.totaliz.: enabling/disabling partial totalizer visualization (this function is always on with batch enabled).

Sec. 8.5 Date/time: enabling/disabling date and time visualization with data logger enabled.

Sec. 8.6 Quick start: enabling/disabling Quick start menu visualization.

Sec. 8.7 Tot.modif.: enabling/disabling the change value of the totalizers.

Sec. 8.8 Net total.: enabling/disabling the visualization page of the net totalizer.

Sec. 8.9 Reset video: enabling/disabling the resetting of the processor of the display.

8-DISPLAY	
Language	EN
D.rate=Hz	1
Contrast=	7
P.totaliz.=	ON
Date/time=	OFF
Quick start=	OFF
Tot.modif.=	OFF
Net total.=	ON
Reset video=	OFF
Currency=	ON
EUR/dm ³ +	1.00000
EUR/dm ³ -	1.00000

Figure 34: Menu 8 Display

9.1.9 Menu 9-Data Logger



These menu functions are not supported.

9.1.10 Menu 10-Diagnostic

Sec. 10.1 Calibration: enabling the automatic calibration of the converter.

Sec. 10.2 Self test: enabling the converter autotest. This function stops the normal functions of the meter and performs a complete test cycle on the measure input circuits and the excitation generator. This function is automatically performed when switching on the device.

Sec. 10.3 Simulation: enabling flow rate simulation. This function will generate an internal signal that simulates the flow rate, allowing the output and all the connected instruments to be tested. After enabling it, the flow rate simulation can be:

- 1) set by pushing the  key from one of visualization pages
- 2) started by pushing the  key after setting it
- 3) finished by pushing the  key from visualization pages and then by pushing the key.

10-DIAGNOSTIC	
Calibration	
Self test	
Simulation=	OFF

Figure 35: Menu 10 Diagnostic

9.1.11 Menu 11-Internal Data

Sec. 11.1 L2 keycode: level 2 access code set-up.

Sec. 11.2 Lock level: Sets block level function (ranges from 0~3).

Sec. 11.3 Load fact.pres.: Resets firmware. This function does not restore McCrometer programmed settings.

Sec. 11.4 Load user pres.: load user data saved.

Sec. 11.5 Save user pres.: save user data.

Sec. 11.6 Hours: visualization of the total operation hours of the converter.

Sec. 11.7 Ign.cal.err: ignore the calibration error during the converter switch-on automatic test.

Sec. 11.8 KS: user applied correction factor.

```

11-INTERNAL DATA
L2 keycode= 00000
Lock level= 3
Load fact.pres.
Load user pres.
Save user pres.
Hours= 000077
Ign.cal.err= OFF
KS= +1.0000
    
```

Figure 36: Menu 11 Internal Data

9.1.12 Menu 12- Batch

These menu functions are not supported.

10.0 Alarm Messages

During meter setup, you may see error messages and codes. These messages and codes are explained below.

MESSAGES	ANOMALIES	ACTION TO TAKE
NO ALARMS	Everything works regularly	-----
MAX ALARM	The flow rate is higher than the maximum threshold set	Check the maximum flow rate setting and process conditions
MIN ALARM	The flow rate is lower than the minimum threshold set	Check the minimum flow rate threshold setting and process conditions
FLOW RATE >FS	The flow rate is higher than the full scale value set on the instrument	Check the full scale value setting on the instrument and the process conditions
PULSE/FREQ .FS	The pulse generation output of the device is saturated and cannot generate sufficient number of impulses	Set a bigger volume unit or, if the connected counting device allows it, reduce the pulse duration value
EMPTY PIPE	The measuring pipe is empty or the detection system has not been properly calibrated	Check whether the pipe is empty or perform the empty pipe calibration procedure again
INPUT NOISY	The measure is strongly effected by external noise or the cable connecting the converter to the sensor is broken	Check the status of the cables connecting the sensor, the grounding connections of the devices or the possible presence of noise sources
EXCITATION FAIL	The coils or the cable connecting the sensor are interrupted	Check the connecting cables to the sensor
CURR. LOOP OPEN	The 0/4-20ma output on board or the optional one are not correctly closed on a valid load	Verify the load is applied to the output (max 1000 ohm). To disable the alarm, set the "mA VAL.FAULT" value (menu alarm) to 0.
P. SUPPLY FAIL	Power supply different from that indicated on the label	Verify that the power supply is the one indicated on the label

ERROR CODES	ANOMALY DESCRIPTION	ACTION TO TAKE
0001	Problem with watch-dog circuit	ADDRESS TO SERVICE
0002	Wrong configuration work data in EPROM	
0004	Wrong configuration safety data in EPROM	
0008	Defective EPROM	
0010	Defective keyboard (one or more keys are pushed during the test)	
0020	Power supply voltage (+3.3) is out of range	
0040	Power supply voltage (+13) is too low (<10V)	
0080	Power supply voltage (+13) is too high (>14V)	
0200	Timeout Calibration input (input circuit is broken)	
0400	Gain input stage is out of range	Check the status of the cables connecting the sensor to the converter, the grounding connections of the devices or the possible presence of strong and anomalous noise sources
0800	Interruption on the coils circuit	Check the status of the cables connecting the sensor to the converter
0C00	Cumulative alarm 0800+0400	See single code

11.0 Maintenance

The Multi-Mag is essentially a maintenance free meter with no user serviceable parts. However, the metered fluid may contain solids or other contaminants which may coat the sensor electrodes. A periodic inspection may be recommended to insure the sensor electrodes are clean. To clean the unit, remove the sensor following all of the instructions and safety warnings contained in *Section 5.0*. When the sensor is removed from the pipe, carefully wipe down the sensor with a soft cloth and rubbing alcohol.

12.0 Specifications

MEASUREMENT

2 and 3 Inch Sensors - Volumetric flow in filled flow conduits 4" (101.6 mm) to 120" (3 m) utilizing insertable electromagnetic averaging sensor. Flow indication in English Std. or Metric units.

FLOW MEASUREMENT

Method: Electromagnetic

Zero Stability: ± 0.03 ft/s (± 0.009 m/s)

Accuracy: $\pm 1\%$ of reading from +0.3 ft/s to +20ft/s + zero stability

Linearity: 0.3% of range

Repeatability: 0.20% of range

Has reverse flow indication.

(Other models available with highly accurate reverse flow measurement capabilities)

Range: (nominal pipe sizes)

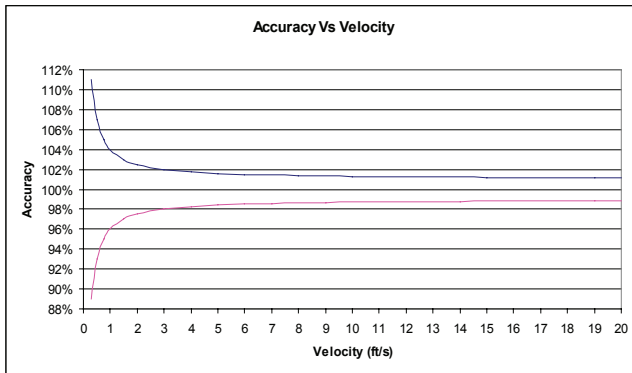

(Contact factory for information on models with bi-directional flow capability or velocities in excess of these specifications.)

Sensor Size-Velocity Range for Pipe Sizes

Velocity Range - 2" Multi-Mag

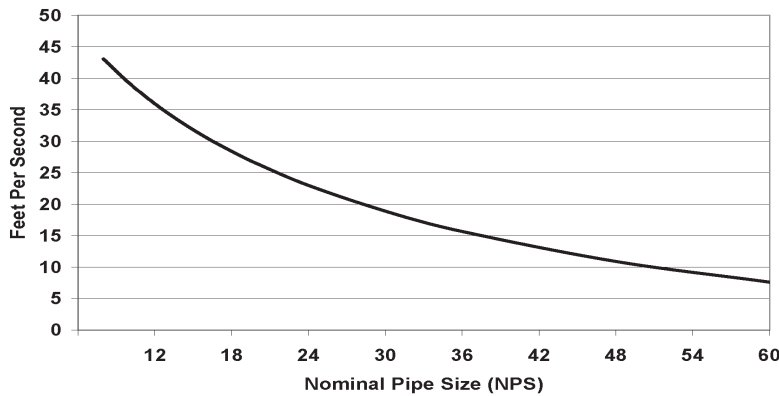

Velocity Range - 3" Multi-Mag

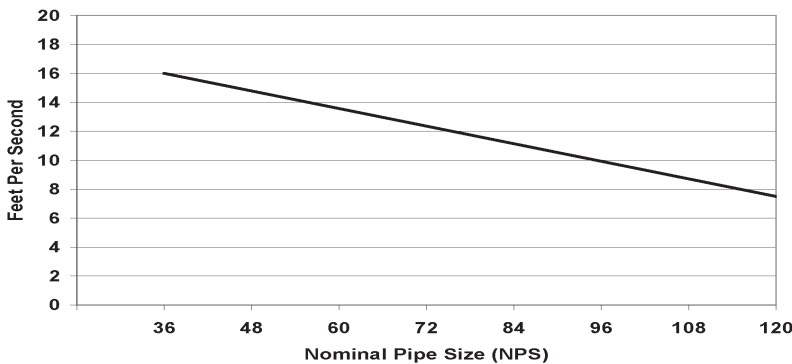

CONDUCTIVITY

Minimum conductivity of 5 μ S/cm (5 μ mho/cm)

POWER REQUIREMENTS

AC: 90-265VAC/44-66 Hz (20W/25VA) or

DC: 10-35VDC (20W)

AC or DC must be specified at time of ordering.

MATERIALS

Sensor:

285: Coated fiberglass

287: Fiberglass

Insertion Hardware: 316 stainless steel exposed to flow.

Compression Seal: Silicone Rubber

Sensor electrodes:

285: 304 stainless steel -

6" to 11" sensor = 3 electrode pairs and 2 grounding pairs;

12" to 60" sensor = 5 electrode pairs and 2 grounding pairs.

287: Carbon- 5 electrode pairs and 5 grounding pairs.

OUTPUTS

Analog: Galvanically isolated and fully programmable for zero and full scale (0-24mA).

Output Capability \leq 20V. (1000 ohm, 4-20 mA)

Second output available as an option.

Two Programmable Displays: 1. Real-time display: indicates flow and velocity; 2. Totalizer display: user selectable engineering units.

Pulse/Frequency: One frequency/pulse output for flow rate or for external totalizer. Capable of sinking <250 mA @ <35V.

DUAL ALARMS

2 separate outputs: Isolated and protected transistor switch capable of sinking <250mA @ <35V. Note: Not isolated from frequency output.

Fully programmable for high/low flow rates, % of range, empty-pipe, fault conditions, forward/reverse, polarity (normally open/close), analog over-range, pulse over-range, pulse cutoff, etc.

TRANSMITTER ENCLOSURE

IP67

5.75" H x 5.75" W x 6.69" D

(14.6cm H x 14.6cm W x 17cm D)

ELECTRICAL CONNECTIONS

Compression gland seals for 0.125" to 0.375" Dia. round cable.

ISOLATION

Galvanic separation to 50VDC between analog, pulse/alarm, and earth/ground.

STANDARDS

CE Certified

Electrical: Meets ANSI/ISA-S82.10-1988 and S82.03-1988

Vibration: Meets BS 2011: Part 2.1Fc: 1983

Potable Water Applications: Suitable for use in contact with potable water. Water Byelaws Scheme (WBS) Approved Product. Meets BS6920 – Cert. #9706516

ENVIRONMENTAL

Pressure/Temperature Limits:

Sensor: Flow Temperature Range

32° to 110° F (0° to 44° C) @ 250 psi

Sensor is submersible (IP68)

Electronics: Operating and storage temperature: -4° to 140°F (-20° to +60°C)

KEYPAD AND DISPLAY

Can be used to access and change all set-up parameters using three membrane keys and an LCD display.

Contact factory for Sensor Mounting Hardware Ordering Information



13.0 Multi-Mag Ordering Information

13.1 The Standard Multi-Mag Includes:

- IP67 rated electronics enclosure
- Three-button numerical keypad
- One graphical backlit LCD display
- Two programmable open-collector outputs
- One 4-20mA output
- Multi-Mag™ Sensor
- 20-foot sensor cable
- Installation and Operation Manual

13.2 Options:

- 4-20mA output
- Extended sensor cable (up to 300', for longer lengths, consult factory).
- Pole mounting kit - Part No.: Consult Factory
- Sensor insertion tool - Part No.: 75031
- Additional Installation and Operation manuals - Part No.: 24510-78

NOTE

A Sensor Specification Sheet (*pages 44 & 45*) should be completed and submitted with all orders.

13.3 Returning A Unit For Repair

If the unit needs to be returned to the factory for repair, please do the following:

- Prior to calling for a return authorization number, determine the model number, serial number (located inside the front panel of converter), and reason for return.
- Call the McCrometer Customer Service Department and ask for a Return Authorization (RA) number.
- Ship the meter in the original packaging, if possible. Do not ship manuals, power cords, or other parts with your unit unless required for repair.
- Please make sure the meter is clean and free from foreign debris prior to shipping.
- Write the RA number on the outside of the shipping box. All return shipments should be insured.
- Address all shipments to:

McCrometer, Inc.
RMA #
3255 W. Stetson Ave
Hemet, CA 92545

Appendix

App. 1.0 Commonly Used Converter Functions

App. 1.1 Zeroing The Totalizer

1. Got to menu "5-Inputs" and change "T+ RESET = ON" and any other of the totalizers to be reset. Example: P+, T- or P- to "ON".
2. Go back to the display screen showing the totalizers.
3. Long push the right hand "Enter" key will display totalizer values.
4. Enter "Keycode L2: 00002" and press Enter key. The totalizers previously assigned to reset will highlight, with the text "RESET TOT?".
5. Long push the Enter key will zero all highlighted totalizers and return to the display screen.
6. Go to menu "5-Inputs" and change "T+ RESET = OFF". Repeat this function for all totalizers previously set to "ON". This insures that the totalizers will be accidently reset.

App. 1.2 Display Net Totalizer

1. Go to menu "8-Display" and set "Net.total. = ON".

App. 1.3 Turning Off Partial Totalizer

1. Go to menu "8-Display" and set "P.totaliz=OFF"

App. 1.4 Output Simulation

1. Go to "Quick Start Menu" and set "Simulation = ON".
2. Exit to display screen.
3. Long push center key and set % of Full Scale Simulation. Short push right hand Enter key.
NOTE: "S" will appear on the screen in one of three locations, depending on the screen:
upper left, lower right or lower center.
4. To Exit Output Simulation long push the Center key to display Simulation %, then long push the Enter key.

App. 2.0 "L" Series Menu Structure And Default (Pre-Set) Values

1-Sensor

ND = 263
 KA = 4.0000
 Sen. type = 000
 KL = + (0)
 KL = - (0)
 Cable Len = 010
 E.p. Detect = ON
 E.i. signal = 130
 AutoZero Cal.
 E.P. calibr.

2-Scale

FS1 =Gal/m 1200.0
 Tot. MU = KGL 00001
 Pls1 = 1.00000
 Tpls1-ms 0050.00
 Mass units = OFF

3-Measure

T-Const = 0006.0
 Filter = s 0.2
 Skip thr = % 125
 Peak thr = % 025
 Cut-off = % 02.0
 Autocal = OFF
 Autorange = OFF
 E. saving = OFF

4-Alarm

Max thr+ = % 110
 Max thr- = % 110
 Min thr+ = % 000
 Min thr - = % 000
 Hyst. = % 05
 E.p. thr. = 250
 mA v.fault = % 010

5-Inputs

T + reset = OFF
 P + reset = ON
 T - reset = OFF
 P - reset = ON
 Puls reset = OFF
 Count lock = OFF
 Calibration = OFF
 Range change =OFF
 Batch = OFF

6-Outputs

Out1 = #1 IMP
 Out 2 = SIGN
 Duty Cycle1 = % 50
 Out. mA1 = 4/20

7-Communication

IF2 prot. = DPP
 Address = 000
 RS485 bps = 19200
 A. delay = mS 20
 Rem, addr = 000
 Remote u. conn.

8-Display

Language = EN
 D. rate = Hz 10
 Contr. range = 0
 Contrast = 7
 P. totaliz = ON
 Date/time = OFF
 Quick start = ON
 Tot. modif = OFF
 Net total = OFF
 Reset Video = OFF
 Currency = OFF

9-Data Logger

6/28/2004 14:15
 Acquisition = OFF
 Display events
 Clear events

10-Diagnostic

Calibration
 Self Test
 Simulation = OFF

11-Internal data

L2 keycode = 00002
 Load fact. Pres.
 Load user pres.
 Save user pres.
 Ign. Cal. err = OFF
 Ks = +1.0000

0-Quick Start

Fs1 =
 Tot. MU =
 T Const =
 ND = mm
 Simulation =
 Contrast
 Language
 Batching Setup
 Regulat. Setup
 Flow meas. Setup
 Main menu

Company Name _____
 Site Tag/ID _____
 Customer Contact _____
 Model/Sensor Type _____
 Date Received _____

MULTI-MAG SENSOR SPECIFICATION SHEET

2" TAPS

Note: Production cannot proceed without this information

Multi-Mag Mounting Hardware

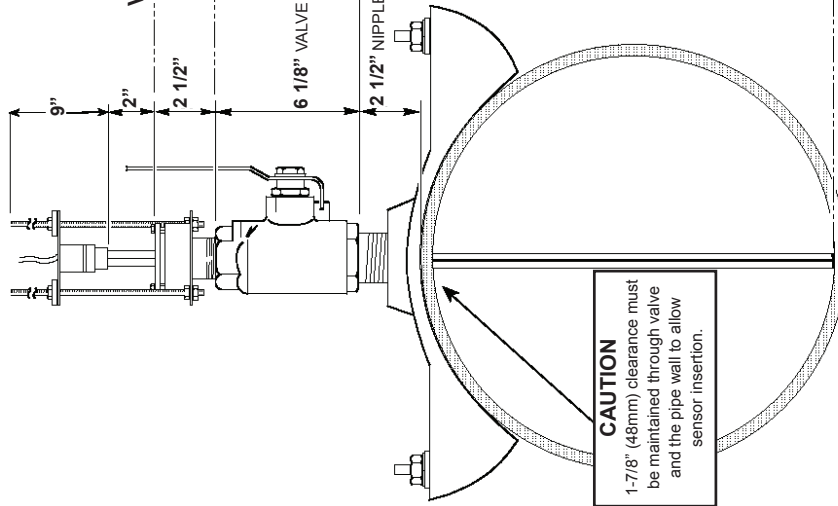

Typical Installations

Valves, Nipples, etc. are accessories or customer supplied. 2" CLEARANCE REQUIRED

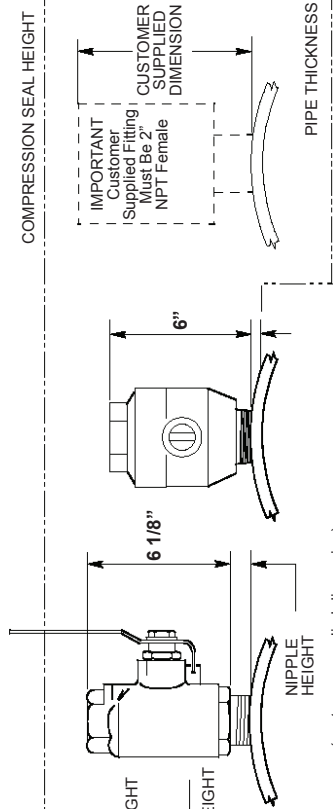

A	2"	VALVE HEIGHT
B	2 1/2"	NIPPLE HEIGHT
C		PIPE THICKNESS
D		CUSTOM STACK HEIGHT ADD A-E
E		
S		

Pipe Material _____
 Schedule Number _____
 Total Cable Length _____
 Fluid Type _____
 Estimated Max Flow _____
 Estimated Min Flow _____
 Estimated Avg. Flow _____
 Estimated Avg. Line Pressure _____

CAUTION
 1-7/8" (48mm) clearance must be maintained through valve and the pipe wall to allow sensor insertion.

IMPORTANT NOTE:
 CHECK HERE TO USE STANDARD STACK HEIGHT (15")
 C+D+E MUST BE LESS THAN 10.5"

ID		INSIDE DIAMETER OF PIPE
T		TOTAL FIBERGLASS LENGTH PIPE ID + STACK HEIGHT
H		STANDARD STACK HEIGHT = 15" CALCULATED DISTANCE H IF PIPE IS CLOSE TO OBSTRUCTION

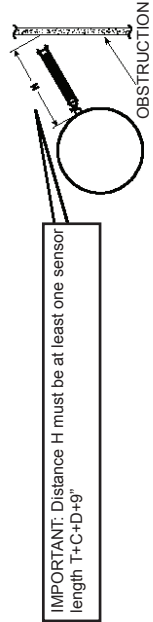

MULTI-MAG SENSOR SPECIFICATION SHEET

3" TAPS

Note: Production cannot proceed without this information

Company Name _____
 Site Tag/ID _____
 Customer Contact _____
 Model/Sensor Type _____
 Date Received _____

Multi-Mag Mounting Hardware

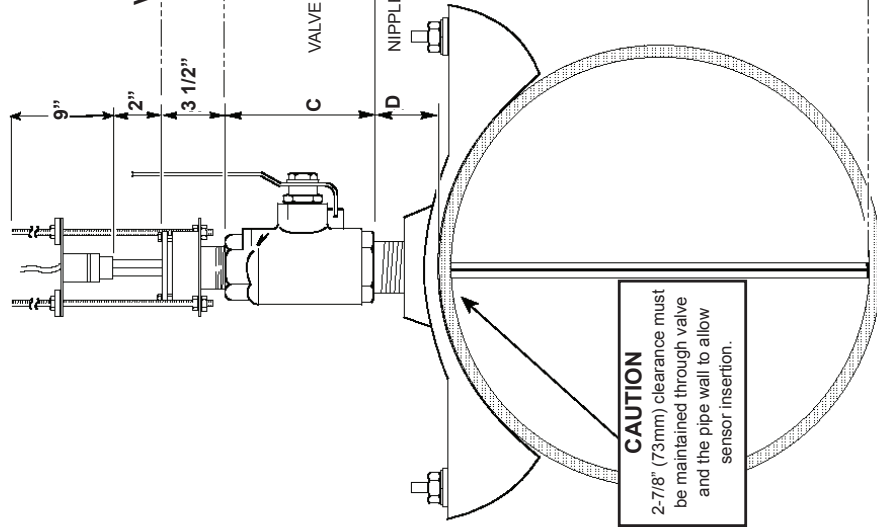

Typical Installations

Valves, Nipples, etc. are accessories or customer supplied. 2" CLEARANCE REQUIRED

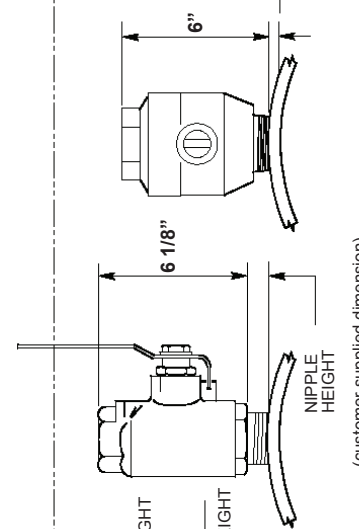

A	2"
B	3 1/2"
C	VALVE HEIGHT
D	NIPPLE HEIGHT
E	PIPE THICKNESS
S	CUSTOM STACK HEIGHT ADD A-E

_____	Pipe Material
_____	Schedule Number
_____	Total Cable Length
_____	Fluid Type
_____	Estimated Max Flow
_____	Estimated Min Flow
_____	Estimated Avg. Flow
_____	Estimated Avg. Line Pressure

IMPORTANT NOTE:
 CHECK HERE TO USE STANDARD STACK HEIGHT (15")
 C+D+E MUST BE LESS THAN 10.5"

ID	INSIDE DIAMETER OF PIPE
T	TOTAL FIBERGLASS LENGTH PIPE ID + STACK HEIGHT
H	CALCULATED DISTANCE H IF PIPE IS CLOSE TO OBSTRUCTION

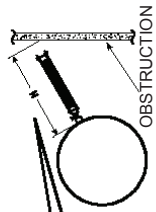

IMPORTANT: Distance H must be at least one sensor length T+C+D+9"



App. 4.0 Conversion Tables

Table of Decimal Equivalents

Fraction	Decimal
1/8	.125
1/4	.25
3/8	.375
1/2	.5
5/8	.625
3/4	.75
7/8	.875

Table of Conversions

Multiply	By	To Get
Centimeters	0.3937	Inches
Centimeters	0.03281	Feet
Inches	25.4	Millimeters
Feet	30.48	Centimeters
Sq. Ft.	144.0	Sq. In
Sq. In	0.006944	Sq. Ft.
Cu. In	0.0005787	Cu. Ft.
Cu. Ft.	7.481	Gallons
Cu. Ft.	1728.0	Cu. In
Cu. Ft.	0.02832	Cu. Meters
Cu. Ft.	28.32	Liters
Cu. Meters	35.31	Cu. Ft.
Cu. Meters	264.2	Gallons
US Gallons	3.785	Liters
US Gallons	0.1337	Cu. Ft.
US Gallons	0.003785	Cu. Meters
US Gallons	.8326748	Imperial Gallons
Liters	0.2642	Gallons
$^{\circ}\text{F} = (^{\circ}\text{C} \times 9/5) + 32$		
$^{\circ}\text{C} = (^{\circ}\text{F} - 32) \times 5/9$		

WARRANTY STATEMENT

Manufacturer warrants all products of its manufacture to be free from defects in workmanship and material under normal use and service. The warranty for the **Multi-Mag** sensor body and hardware extends for a period of (24) months after the date of shipment. The warranty for the electronic converter extends for a period of twelve (12) months after date of shipment, unless altered by mutual agreement between the purchaser and manufacturer prior to the shipment of the product. If this product is believed to be defective and is within its warranty period, purchaser shall notify the manufacturer, and will return the product to the manufacturer, postage paid, within twenty-four (24) months after date of shipment by the manufacturer of the sensor body and hardware, or twelve (12) months after the date of shipment by the manufacturer for the electronic converter. If the purchaser believes the return of the product to be impractical, manufacturer shall have the option, but will not be required, to inspect the product wherever located. In any event, if the purchaser requests the manufacturer visit their location, the purchaser agrees to pay the non-warranty expenses of travel, lodging and subsistence for the field service response. If the product is found by the manufacturer's inspection to be defective in workmanship or material, the defective part or parts will either be repaired or replaced, at manufacturer's election, free of charge, and if necessary the product will be returned to purchaser, transportation prepaid to any point in the United States. If inspection by the manufacturer of such product does not disclose any defect of workmanship or material, manufacturer's regular service repair charges will apply. Computing devices sold but not manufactured by McCrometer, Inc. are covered only by the original manufacturer's written warranty. Hence, this warranty statement does not apply.

THE FOREGOING WARRANTY IS MANUFACTURER'S SOLE WARRANTY, AND ALL OTHER WARRANTIES, EXPRESS, IMPLIED OR STATUTORY, INCLUDING ANY IMPLIED WARRANTY OF MERCHANTABILITY OR FITNESS FOR A PARTICULAR PURPOSE, ARE NEGATED AND EXCLUDED. THE FOREGOING WARRANTY IS IN LIEU OF ALL OTHER WARRANTIES, GUARANTEES, REPRESENTATIONS, OBLIGATIONS OR LIABILITIES ON THE PART OF THE MANUFACTURER.

Purchaser's sole remedy and manufacturer's sole obligation for alleged product failure, whether under warranty claim or otherwise, shall be the aforesated obligation of manufacturer to repair or replace products returned within twelve months after date of original shipment. The manufacturer shall not be liable for, and the purchaser assumes and agrees to indemnify and save harmless the manufacturer in respect to, any loss or damage that may arise through the use by the purchaser of any of the manufacturer's products.

OTHER McCROMETER PRODUCTS INCLUDE:



Magnetic Flowmeters



Magnetic Flowmeters



Magnetic Flowmeters



Propeller Flowmeters



Flowmeters And Flow Straighteners



For Propeller Flowmeters



Propeller Flowmeters



Differential Pressure Flowmeters

The Space Saver Solution



Differential Pressure Flowmeters



Differential Pressure Flowmeters

Electronic Instrumentation for Remote Display and Control