

# Installation & Operation

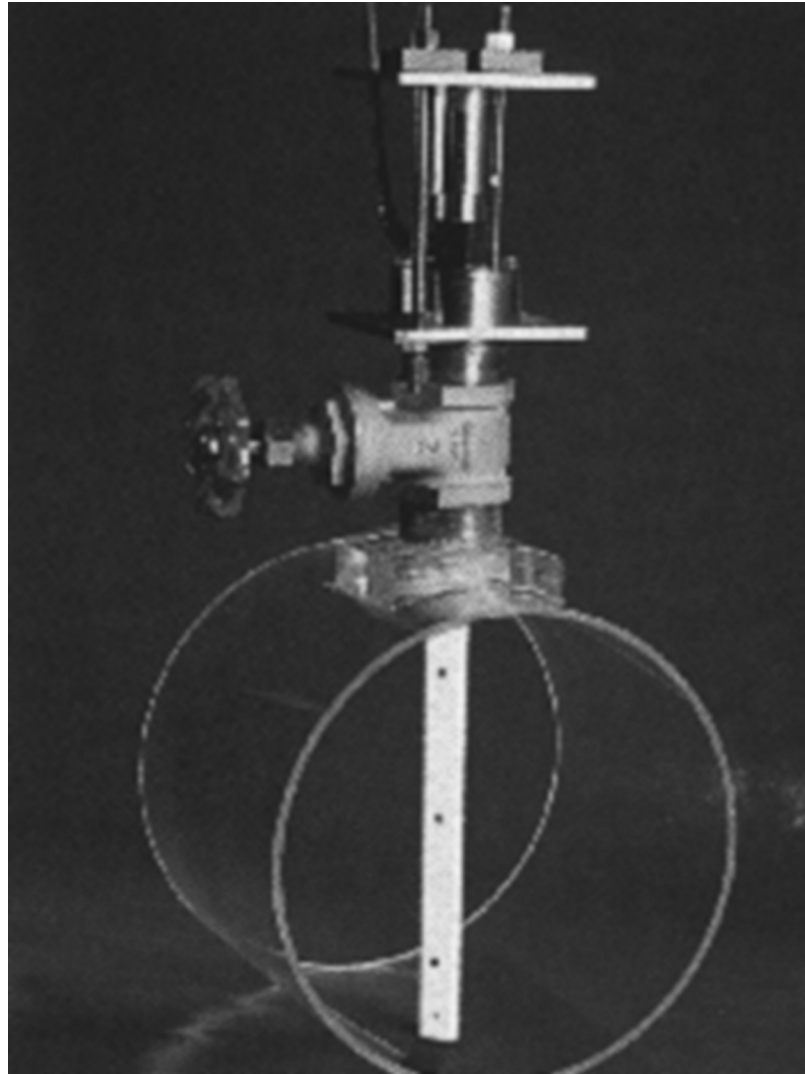

## Marsh Multi-Mag™ 2" Insertable Electromagnetic Averaging Magmeter

Model 284



# Contents

<b>1. Warranty .....</b>	<b>1</b>
<b>2. Safety Warnings .....</b>	<b>2</b>
<b>3. Marsh Multi-Mag™ Model 284.....</b>	<b>3</b>
Instrument Overview .....	3
Principle of operation.....	4
<b>4. Installation .....</b>	<b>5</b>
Sensor Installation.....	6
Site Selection .....	6
Sensor Mounting Hardware .....	6
Pulling Sensor Cable Through Underground Electrical Conduit.....	6
Sealing Underground Electrical Conduit .....	6
Location, Position, and Clearance .....	7
Sensor clearance.....	7
Multi-Mag Sensor and Insertion Hardware - Parts Diagram .....	8
Install pipe valve .....	9
Using a corporation stop .....	9
Using a pipe valve.....	9
Install Sensor Assembly on the Valve .....	10
Insert the Sensor.....	11
Sensor Load .....	13
Install the short restraining rods.....	13
Assembling or Disassembling the Sensor.....	15
Attach the Top Plate to the Sensor .....	15
Restraining rod and compression seal assembly.....	16
Electronics Installation.....	17
Mount the electronic housing.....	17
Electrical Cable Connections.....	18
Terminal Board .....	18
Sensor Cable .....	18
0/4~20/22 mA Hookup .....	19
Opto-Isolated Pulse Output Hookup.....	19
Converter AC Power Hookup .....	20
Instrument Start-Up .....	24
<b>5. Setting up the Model 284 .....</b>	<b>25</b>
Front Panel Key Pad and Display .....	26
Factory Pre-Setting .....	27
Access Codes .....	27
Block Levels .....	27
Programming the Converter.....	28
Main Menu.....	32

<b>5. Setting up the Model 284 (continued)</b>	
Menu 1-Sensor .....	32
Menu 2-Scales .....	33
Menu 3-Measures .....	34
Menu 4-Alarms .....	35
Menu 5-Inputs .....	36
Menu 6-Outputs .....	37
Menu 7-Communication .....	39
Menu 8- Display .....	40
Menu 9-Data Logger .....	41
Menu 10-Diagnostic .....	41
Menu 11-Internal Data .....	42
Menu 12-Batch .....	42
Alarm Messages .....	46
<b>6. Appendix - Application Schematics .....</b>	<b>47</b>
Clearance .....	47
Skewed Profiles .....	47
<b>7. Specifications .....</b>	<b>55</b>
<b>8. Model 284 Ordering Information.....</b>	<b>56</b>
Spare Parts List .....	57
Returning a Unit for Repair .....	57
<b>9. Conversion Tables .....</b>	<b>58</b>
Table of Decimal Equivalents .....	58
Table of Conversions .....	58



## WARRANTY STATEMENT

Manufacturer warrants all products of its manufacture to be free from defects in workmanship and material under normal use and service. This warranty extends for a period of twelve (12) months after date of shipment, unless altered by mutual agreement between the purchaser and manufacturer prior to the shipment of the product. In addition, the Multi-Mag sensor is warranted for an additional forty-eight (48) months (60 months total). If this product is believed to be defective, purchaser shall notify manufacturer and will return the product to the manufacturer, postage paid, within twelve (12) months after date of shipment (60 months for the sensor) by the manufacturer. If the purchaser believes the return of the product to be impractical, manufacturer shall have the option, but will not be required, to inspect the product wherever located. In any event, if the purchaser requests the manufacturer visit their location, the purchaser agrees to pay the non-warranty expenses of travel, lodging and subsistence for the field service response. If the product is found by the manufacturer's inspection to be defective in workmanship or material, the defective part or parts will either be repaired or replaced, at manufacturer's election, free of charge, and if necessary the product will be returned to purchaser, transportation prepaid to any point in the United States. If inspection by the manufacturer of such product does not disclose any defect of workmanship or material, manufacturer's regular service repair charges will apply. Computing devices sold but not manufactured by McCrometer, Inc. are covered only by the original manufacturer's written warranty. Hence, this warranty statement does not apply.

**THE FOREGOING WARRANTY IS MANUFACTURER'S SOLE WARRANTY, AND ALL OTHER WARRANTIES, EXPRESS, IMPLIED OR STATUTORY, INCLUDING ANY IMPLIED WARRANTY OF MERCHANTABILITY OR FITNESS FOR A PARTICULAR PURPOSE, ARE NEGATED AND EXCLUDED. THE FOREGOING WARRANTY IS IN LIEU OF ALL OTHER WARRANTIES, GUARANTEES, REPRESENTATIONS, OBLIGATIONS OR LIABILITIES ON THE PART OF THE MANUFACTURER.**

Purchaser's sole remedy and manufacturer's sole obligation for alleged product failure, whether under warranty claim or otherwise, shall be the aforesated obligation of manufacturer to repair or replace products returned within twelve months after date of original shipment. The manufacturer shall not be liable for, and the purchaser assumes and agrees to indemnify and save harmless the manufacturer in respect to, any loss or damage that may arise through the use by the purchaser of any of the manufacturer's products.

## Safety warnings

When installing, operating, and maintaining McCrometer equipment where hazards may be present, you must protect yourself by wearing Personal Protective Equipment (PPE) and be trained to enter confined spaces. Examples of confined spaces are manholes, pumping stations, pipelines, pits, septic tanks, sewage digesters, vaults, degreasers, storage tanks, boilers, and furnaces.

You must follow all state and local laws, as well as Occupational Health and Safety Administration (OSHA) regulations concerning Personal Protective Equipment, confined-space entry, and exposure to bloodborne pathogens. Specific requirements can be found in the OSHA section of the Code of Federal Regulations: *29 CFR, 1910.132 - 1910.140, Personal Protective Equipment; CFR Title 29, Part 1910.146, Permit-Required Confined-Spaces; and 29 CFR, 1910.1030, Bloodborne Pathogens.*

### **WARNING!**

**Never enter a confined space without first testing the air at the top, middle, and bottom of the space.** The air may be toxic, oxygen deficient, or explosive. Do not trust your senses to determine if the air is safe. You cannot see or smell many toxic gases.

### **WARNING!**

**Never enter a confined space without the proper safety equipment.** You may need a respirator, gas detector, tripod, lifeline, and other safety equipment.

### **WARNING!**

**Never enter a confined space without standby/rescue personnel within earshot.** Standby/rescue personnel must know what action to take in case of an emergency.

### **WARNING!**

**Pressurized pipes should only be tapped, cut, or drilled by qualified personnel. If possible, depressurize and drain the pipe before attempting any installation.**

# Marsh Multi-Mag™ Model 284

## Instrument Overview

The Model 284 Multi-Mag™ flowmeter combines the innovative Multi-Mag™ sensor with a comprehensive electronics package to provide accurate flow measurement for full-pipe clean water applications.

The sensor is easily installed (without system shutdown), and requires no site calibration. By using multiple electrodes, the electromagnetic sensor accurately measures average velocity directly.

The instrument has all of the features needed to suit a wide variety of applications, and is easily set up using the keypad and readouts.

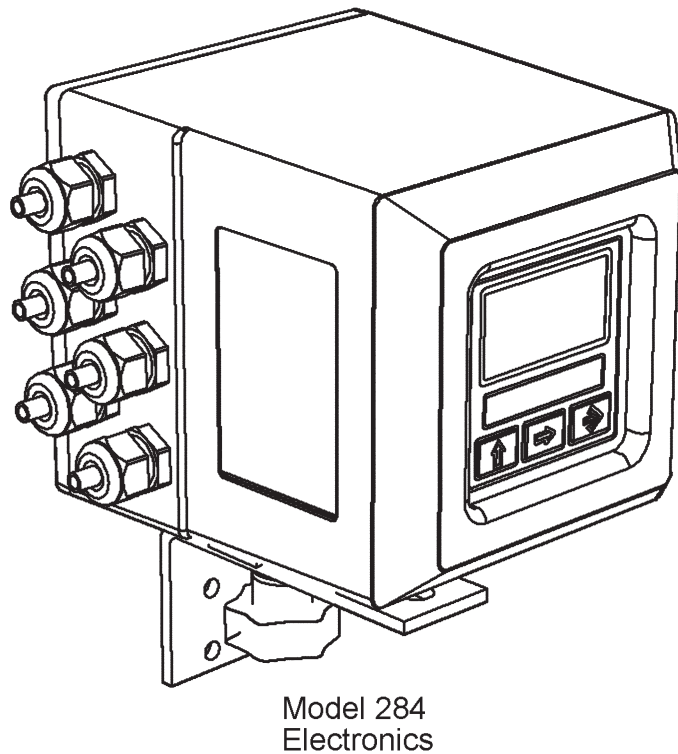
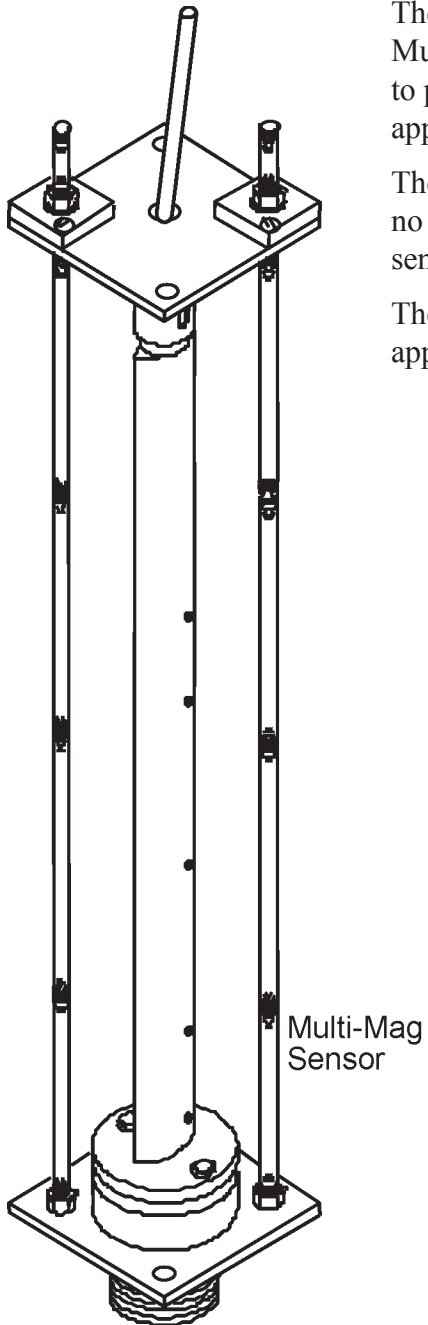

# Principle of operation

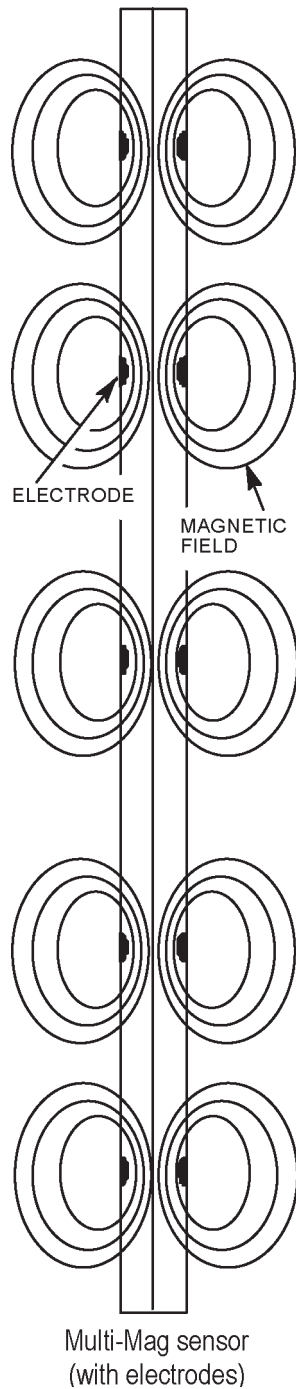

The Multi-Mag makes use of *Faraday's Law of Electromagnetic Induction* to measure water velocity. Faraday's Law states:

**A conductor, moving through a magnetic field, produces a voltage.**

Because water is a conductor, water moving through a magnetic field produces a voltage. The magnitude of the voltage is directly proportional to the velocity at which the water moves through the magnetic field. Five electromagnetic coils inside the sensor produce five magnetic fields, and five sets of carbon electrodes on the sensor's surface measure the voltage generated by the moving water.

## NOTE

For sensors less than 12" long, there are three sets of electrodes.

The electrode pairs are located so that each measures an equal cross-sectional area (see below). The velocity measurements are added together, providing an area-weighted average velocity across the pipe centerline. Flow is then calculated by multiplying the average velocity by the cross-sectional area of the pipe.

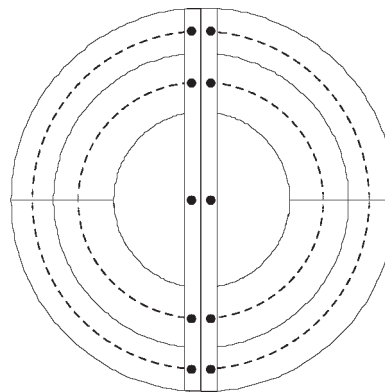

Pipe cross-section (with sensor in center). Each electrode measures an equal area of the cross-section.



The Multi-Mag™ Model 284 is installed in two stages:

- 1** Multi-Mag™ sensor installation
- 2** Electronics installation and connection

This chapter includes both installation stages. After the sensor and electronics are installed, the instrument is set up for the site. This is included in Chapter 2, *Setting up the Model 284*.

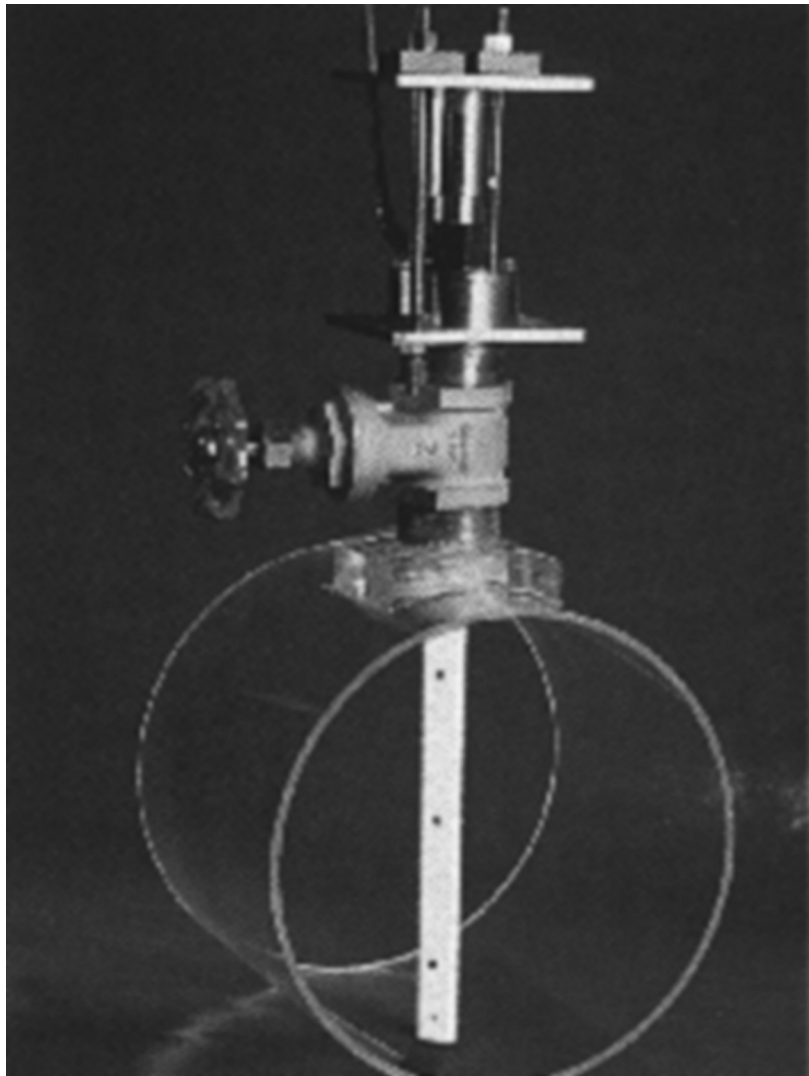

# Sensor installation

Please read the following information before installing the Multi-Mag™ sensor.

## Site selection

Install the sensor at an adequate distance from elbows, T-junctions, Y junctions, active valves, etc. Whenever possible, install the sensor downstream from a bend or junction.

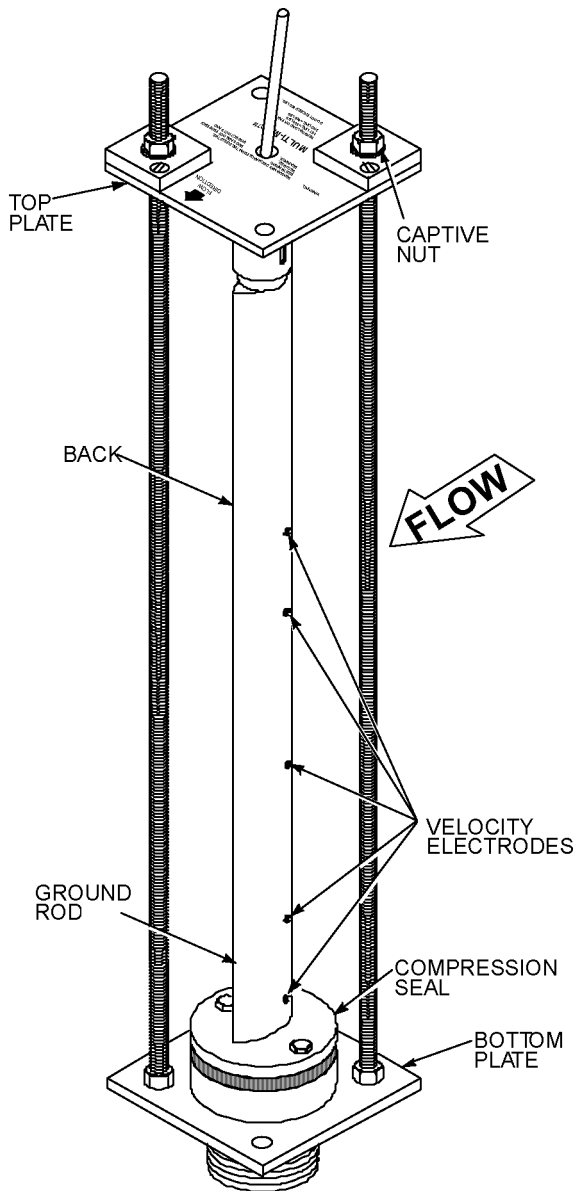

Multi-Mag sensor assembly

Refer to the Application Schematics (located in the Appendix) to find the best sites for several typical applications.

## Sensor mounting hardware

The Multi-Mag™ sensor is inserted into the pipe through a 2" corporation stop or valve.

## Pulling sensor cable through underground electrical conduit

Pools of water may collect in underground electrical conduit. If the sensor cable is pulled through underground electrical conduit, seal the end of the sensor cable with electrical tape to keep water out of the sensor cable.

## Sealing underground electrical conduit

Electrical conduit that is run from a manhole or vault must be sealed to keep corrosive or dangerous gases out of the meter electronics.

Multi-Mag sensor assembly (2" Sensor)

## Location, position, and clearance

To find the best sensor location, refer to the application schematics located in the appendix to this manual.

In general, locate the sensor downstream from pipe bends, junctions, or obstructions. Install the sensor 90° out of plane from upstream elbows.

If you have any questions, or would like technical assistance in selecting the best possible location for installing the Multi-Mag sensor, please call the McCrometer Customer Service Department (1-800-220-2279).

### ***Sensor clearance***

Because the sensor will protrude from the pipe when installed, a clearance of at least the total sensor length plus the distance from the outer pipe wall to the top of the valve plus 9" (229 mm) (distance H, below) must be allowed. See Multi-Mag Sensor Specification (2" and 3" Sensor Specification Sheet).

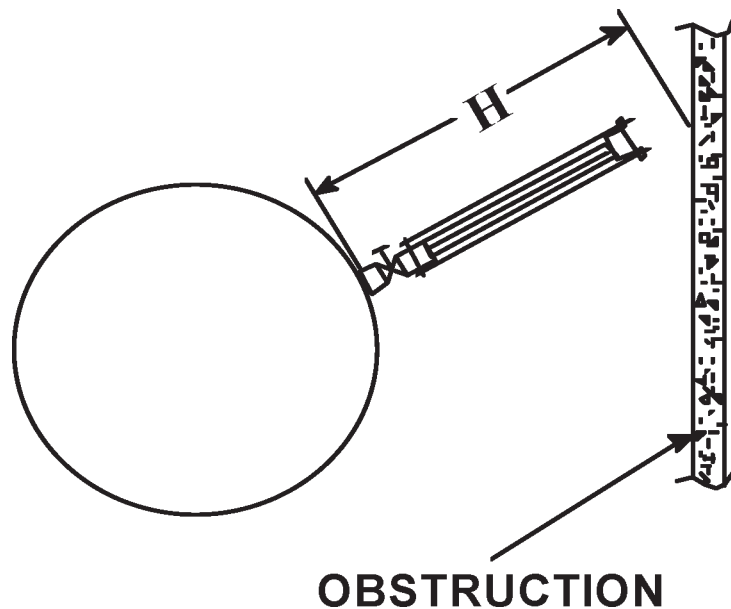

# Multi-Mag Sensor and Insertion Hardware - Parts Diagram

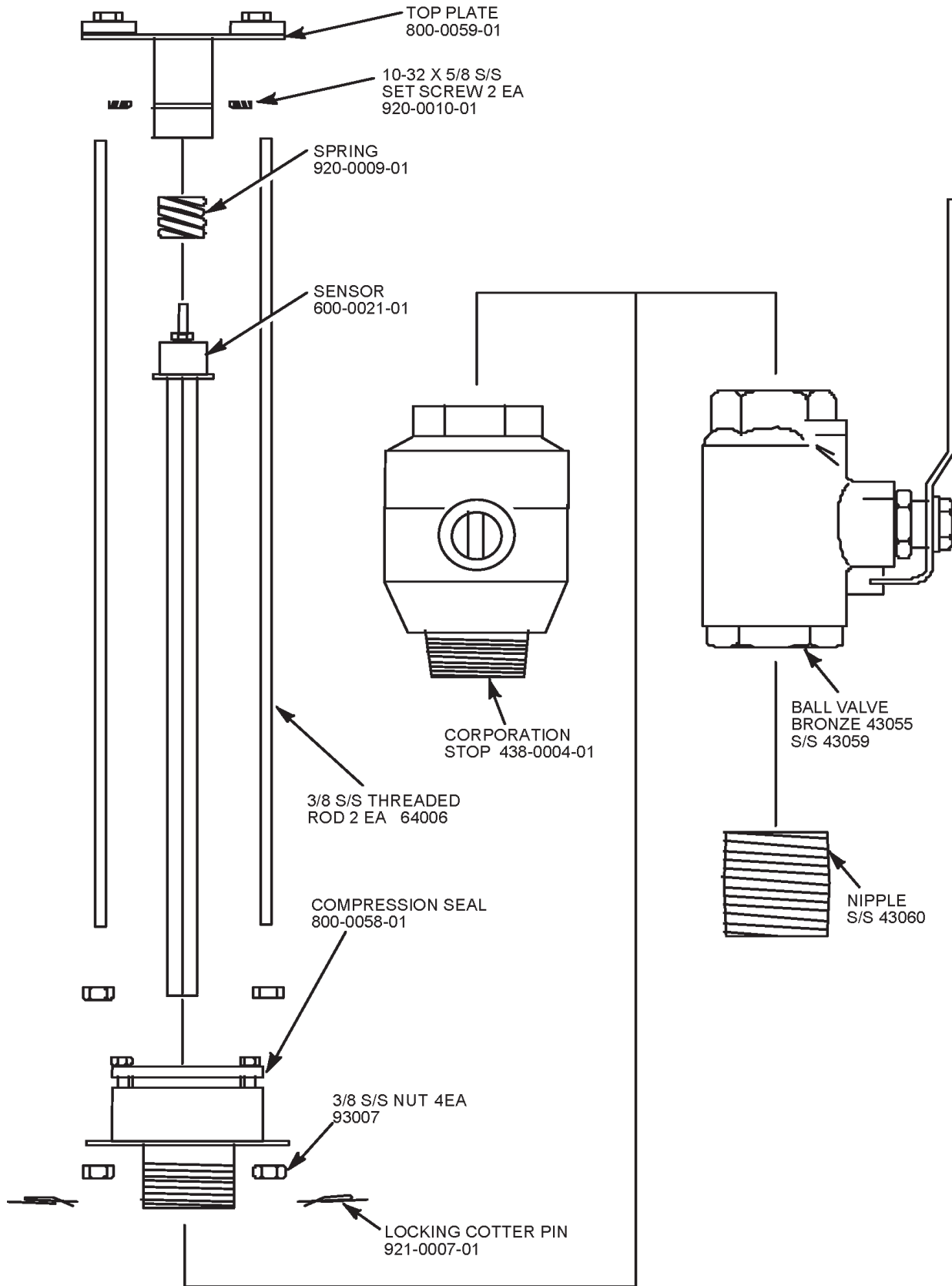

## Install pipe valve

### **WARNING!**

Pressurized pipes should only be tapped, cut, or drilled by qualified personnel. If possible, depressurize and drain the pipe before attempting any installation.

### *Using a corporation stop*

Install a 2" (50mm), full port corporation stop with a 2" (50mm) NPT female pipe thread output (McCrometer part number 438000401). Follow the installation instructions for the corporation stop.

### *Using a pipe valve*

- 1** Install a pipe nipple using a pipe saddle, welded thread-o-let, or other means.
- 2** Install a 2", full port valve (ball or gate).
- 3** Make an access hole in the pipe (2" (50mm) recommended, 1-7/8" (48mm) minimum).
- 4** If possible, save the pipe section removed when the access hole is made. This can be used to verify the pipe thickness.

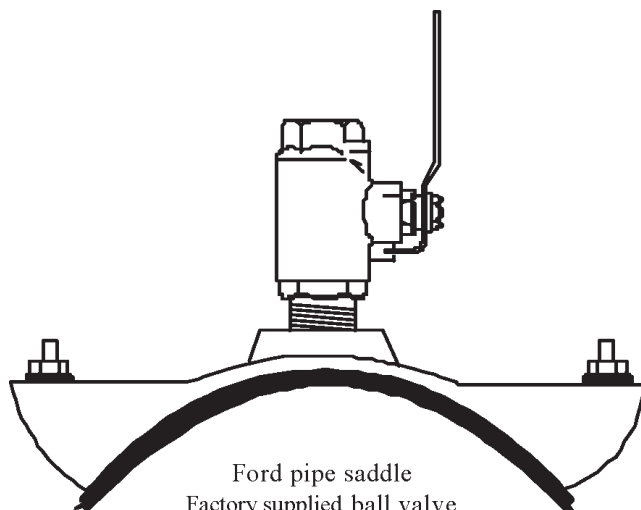

Ford pipe saddle  
Factory supplied ball valve  
Bronze PN 43055 or S/S PN 43059  
Factory supplied nipple  
S/S PN 43060

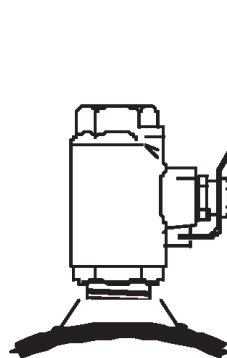

Welded pipe nipple with  
Factory supplied ball valve  
Bronze PN 43055 or S/S PN 43059

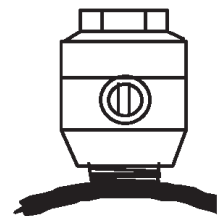

Factory supplied  
corporation stop  
P/N 438-0004-01

## Install sensor assembly on the valve

The sensor assembly uses a compression seal, which keeps the sensor watertight when the pipe is under pressure. Care must be taken when installing the sensor, to avoid leaks.

- 1** Put a liberal amount of the pipe sealant (supplied with the sensor) on the compression seal threads. (Teflon tape may also be used.)
- 2** Place the compression seal threads over the pipe valve. Turn the entire sensor assembly clockwise to secure the assembly to the valve.
- 3** The seal is secure when a large amount of force is required to turn the assembly. Line up the arrow (on the top plate) with the direction of the flow. The sides of the bottom plate should be parallel with the pipe.

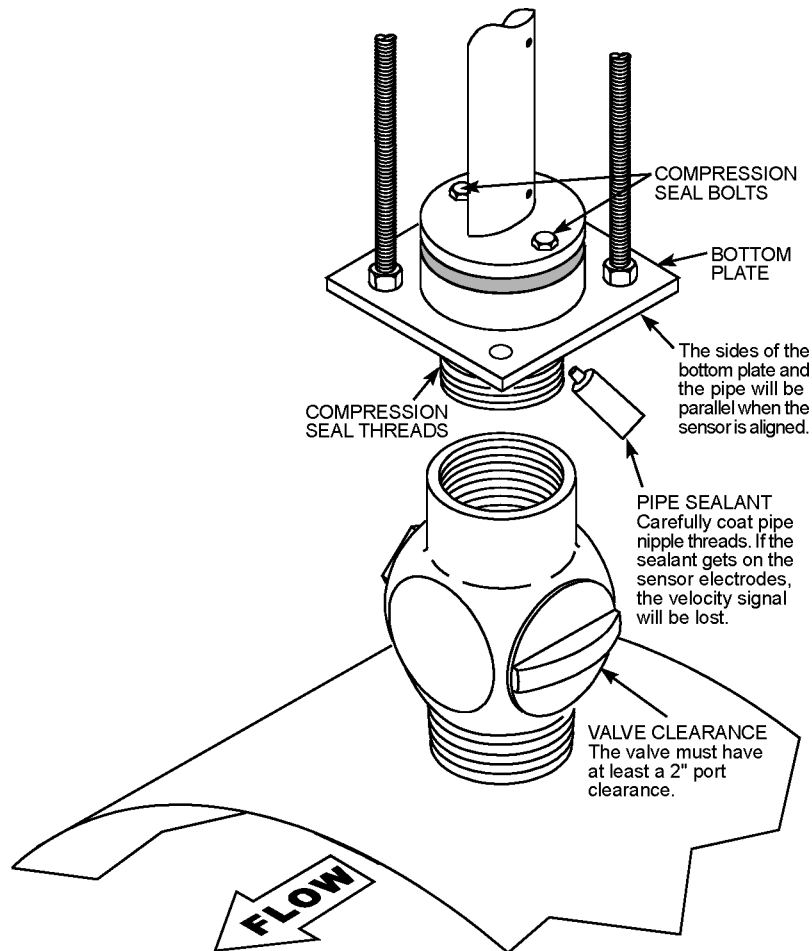

## Insert the sensor

### NOTE

The water velocity should be as slow as possible when the sensor is installed (to prevent sensor vibration). The velocity must be under 5 ft/sec (1.5 m/sec), optimum is zero.

- 1 The compression seal and sensor may be lubricated with liquid dish washing soap. This will prevent the compression seal from binding, as well as ease insertion. (IMPORTANT: Do not use oil or grease-based lubricants, as they could coat the electrodes, causing a velocity signal loss.)
- 2 Tighten the two compression seal bolts (located on the sensor bottom plate) only enough to seal the sensor. If the compression seal bolts are too tight, the compression seal may grip the sensor, and will distort when the sensor is moved into the pipe. The compression seal bolts will be tightened completely after the sensor is fully inserted.

### CAUTION

The compression seal/sensor assembly may be under pressure. Serious injury may result if proper procedures are not followed. Do not attempt to install the sensor without the restraining rods fully assembled.

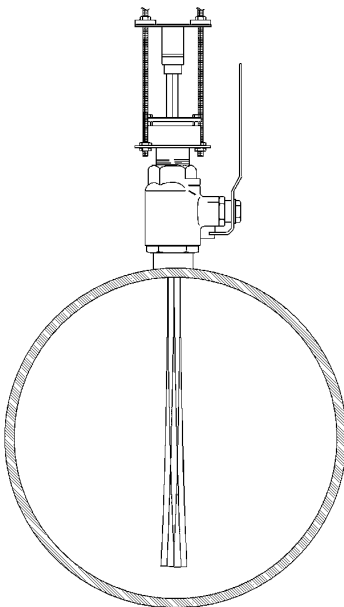

Sensor vibration

- 3 After the sensor assembly (with restraining rods in place) has been installed onto the valve, fully open the valve. If the valve is not fully open, it may scrape the side of the sensor.

- 4 Insert the sensor into the pipe by simultaneously rotating the two captive nuts on the top plate clockwise with the two ratchet wrenches provided.

**NOTE**

If the captive nuts are not tightened simultaneously, the top plate will become crooked and the captive nuts will bind.

A profiling insertion tool (P/N 75031) is available to help with inserting the sensor. Place the profiling insertion tool over the captive nuts and rotate the high gear shaft clockwise until the bottom of the sensor reaches the far wall of the pipe. The low gear shaft is used when torque on the high gear is excessive due to high pressure in the pipe.

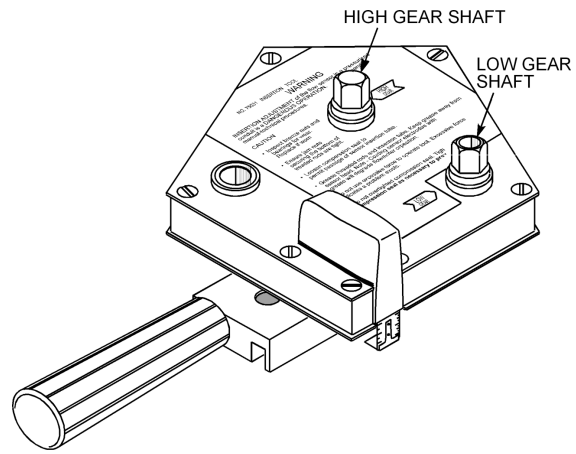
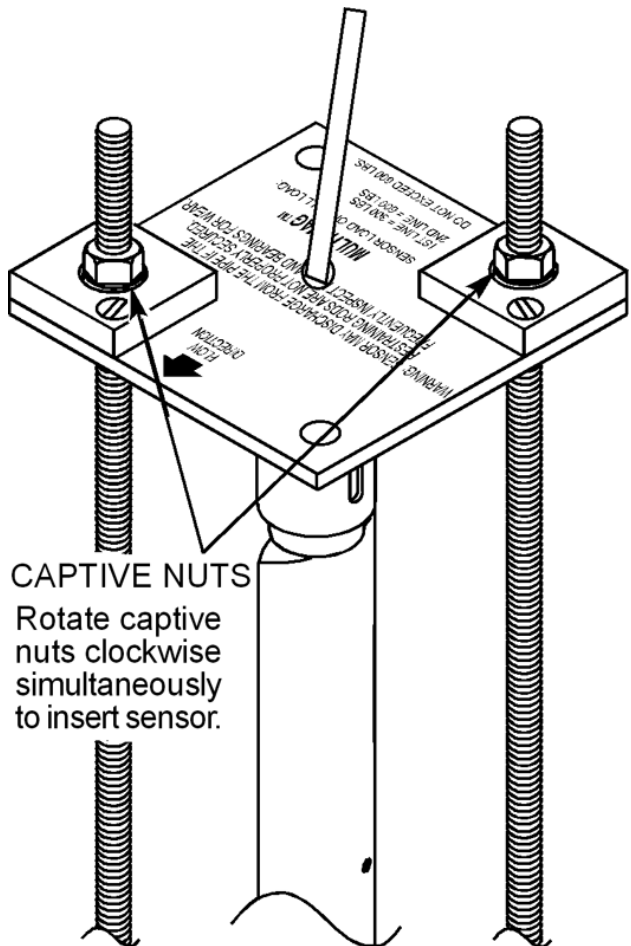

Profiling Insertion Tool



## Sensor load

A load is applied at the top of the sensor forcing the bottom of the sensor against the far wall. This keeps the sensor firmly in place against the far wall of the pipe. The amount of load is indicated by the two lines and set screw at the top of the sensor (see drawing). The bottom line indicates a 300-lb. load. The top line indicates a 600-lb. load.

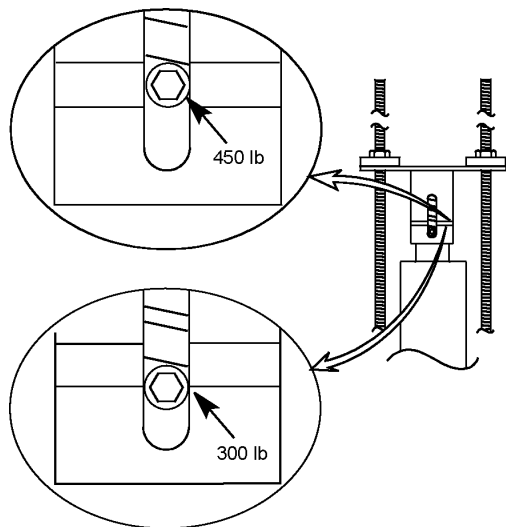

- 1 Rotate the low gear shaft until the proper load is indicated.

Recommended sensor loads are 300 lbs. or less for plastic pipes, 450 lbs. for metal pipes.

- 2 Tighten the compression seal bolts.

## Install the short restraining rods

After the sensor has been inserted and the load adjusted, shorter restraining rods can be installed and the longer ones removed. This will make the sensor assembly compact and reduce the chances of injury by the protruding rods.

- 1 Secure the short restraining rods to the bottom plate with two 3/8" nuts and a locking cotter pin per rod.
- 2 Secure the short restraining rods to the top plate with one 3/8" nut per rod.
- 3 Remove the long restraining rods.
- 4 Check and adjust the "Sensor Load" as necessary.
- 5 Secure the 3/8" nuts on the top plate by running a second jam nut down and tightening it against the first nut.

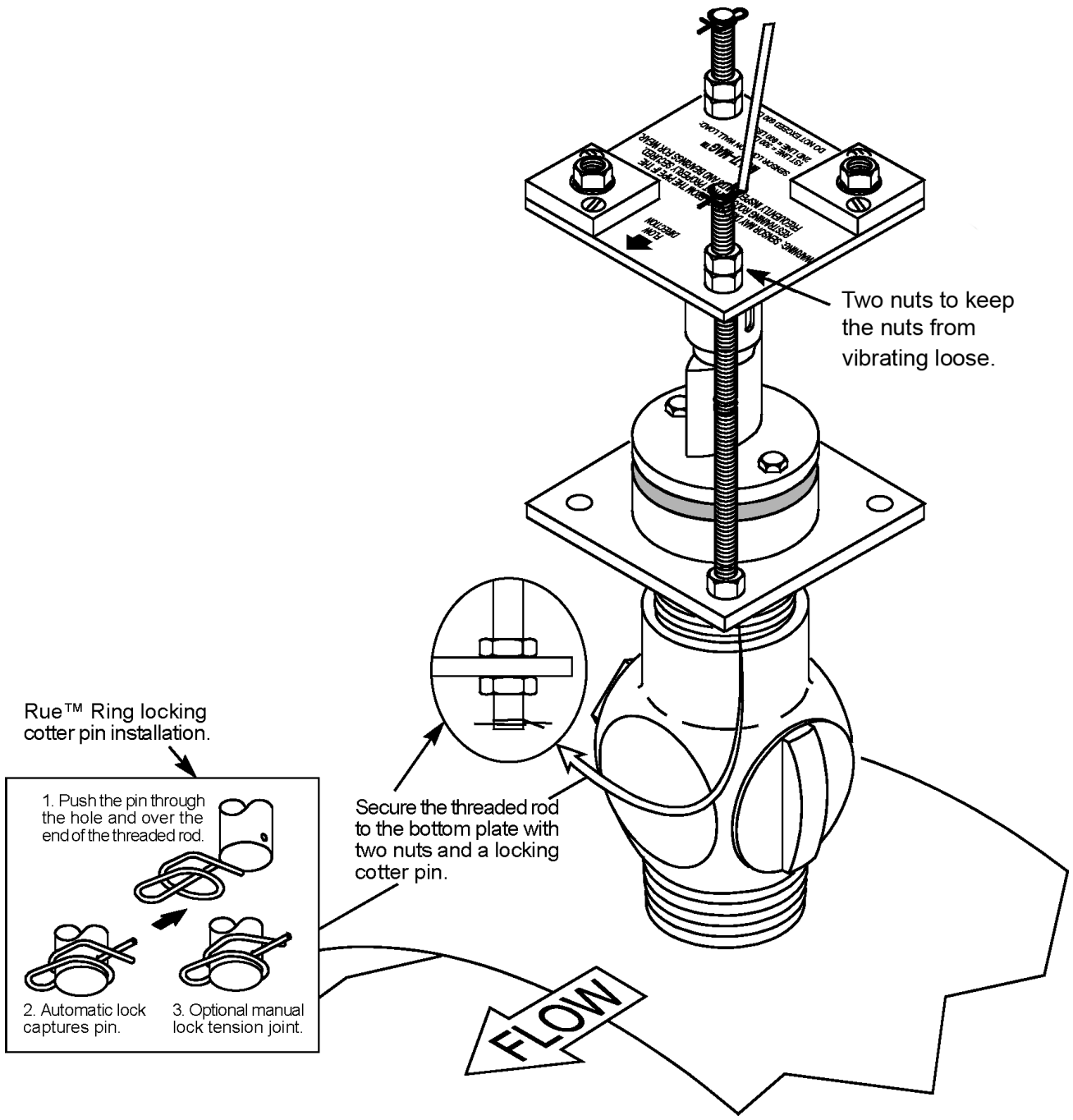

# Assembling or disassembling the sensor

The sensor is shipped fully assembled. However, if sensor repair or replacement is required, the sensor may need to be disassembled or reassembled. To disassemble the sensor, follow the assembly instructions in reverse.

## Attach the top plate to the sensor

- 1 Place the spring on top of the tension indicator at the top of the sensor.
- 2 Slide the spring housing of the top plate over the spring. Secure the top plate to the sensor with the two stainless steel 1032 x 5/8 set screws. Use a 3/32 hex key wrench to tighten the set screws.

### **IMPORTANT**

Make sure the sensor is aligned with the flow arrow on the top plate. The sensor is aligned when the electrodes are facing the opposite direction from the flow arrow.

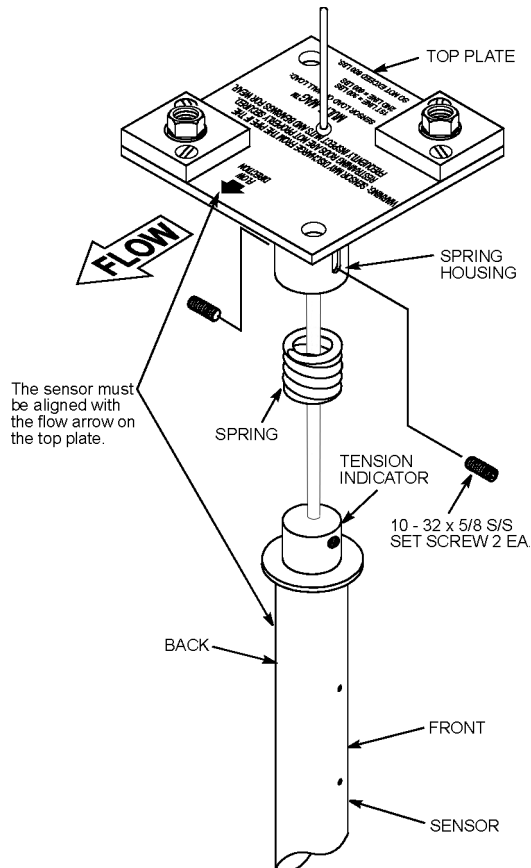

## Restraining rod and compression seal assembly

- 1 Screw the restraining rods onto the captive nuts on the top plate until the restraining rods are about an inch above the captive nuts. The distance above the captive nuts for both restraining rods should be equal.
- 2 Screw one 3/8-16 S/S nut up about an inch onto the bottom of each restraining rod.
- 3 Insert the restraining rods through the appropriate holes in the compression seal bottom plate and secure with 3/8-16 S/S nuts.
- 4 Insert the locking cotter pins to keep the bottom nuts from vibrating loose.

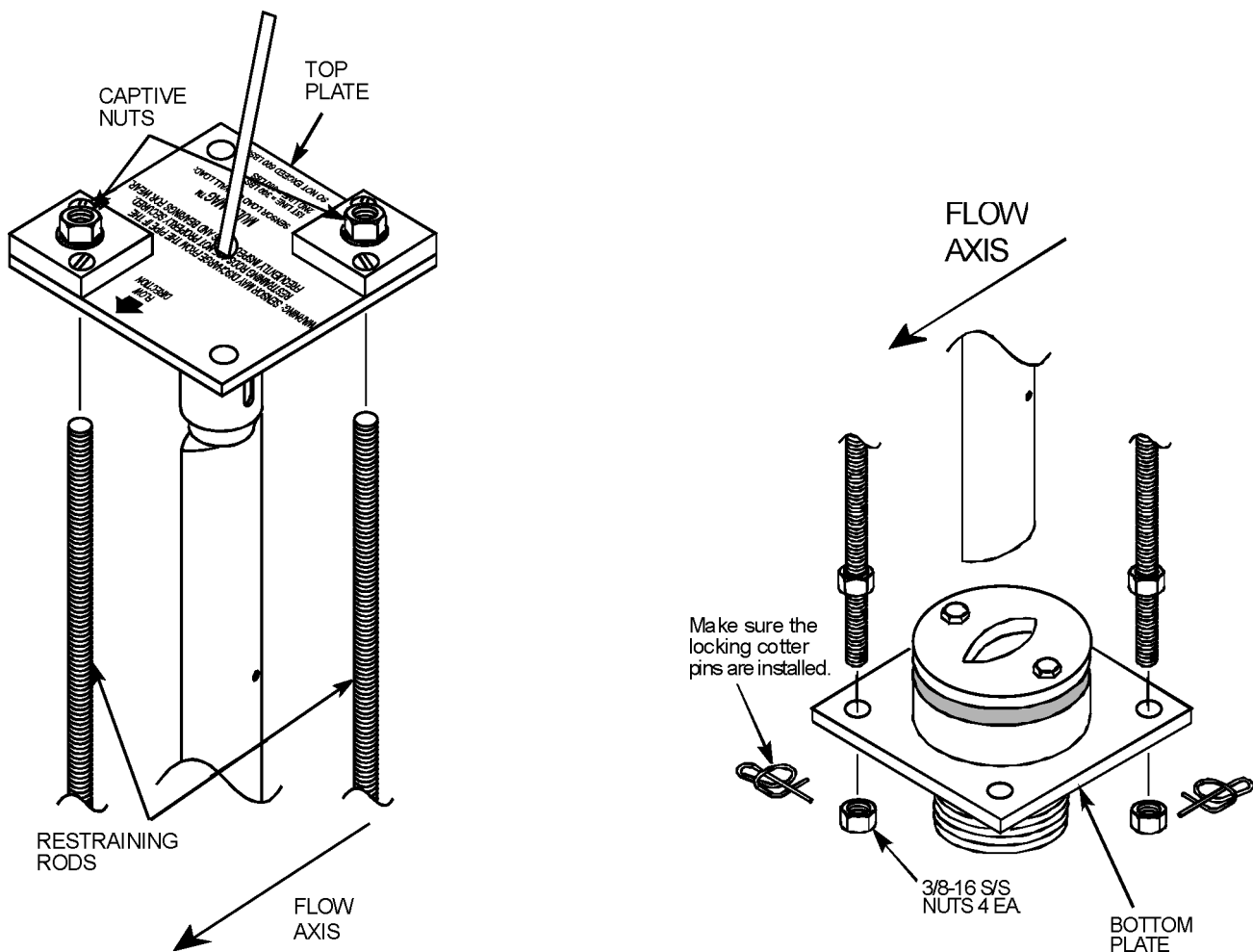

# Electronics installation

## Mount the electronic housing

Mount the 284 electronic unit preferably in an electronics shed or environmental enclosure. If mounted outdoors, a sun shield is recommended. The converter is mounted using 2 bolts (see dimensions, below). The 284 electronic unit is not suitable for underground vault or manhole installations.

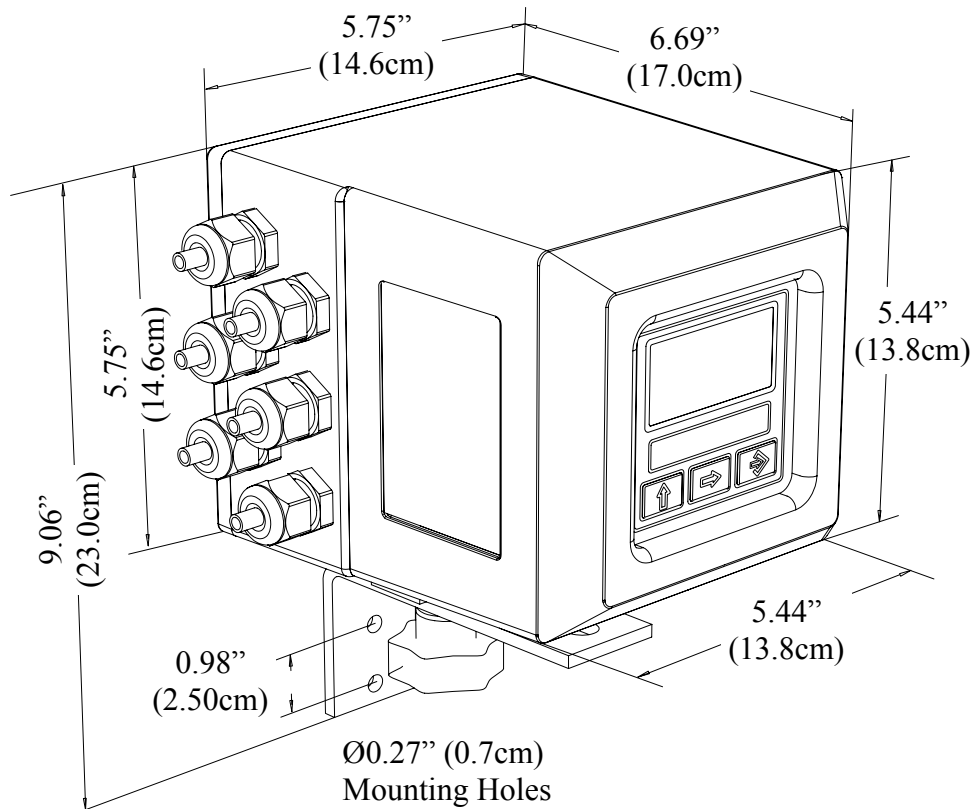

## Electrical cable connections

### CAUTION

Always disconnect the AC power cord before attempting any electrical connections.

All electrical cables enter the unit through compression fittings located on the side of the converter. Ensure that all unused fittings are plugged so the case remains sealed.

### Terminal board

All connections are made on the terminal board. To access the terminal board, loosen the four screws on the back of the converter to remove the rear cover.

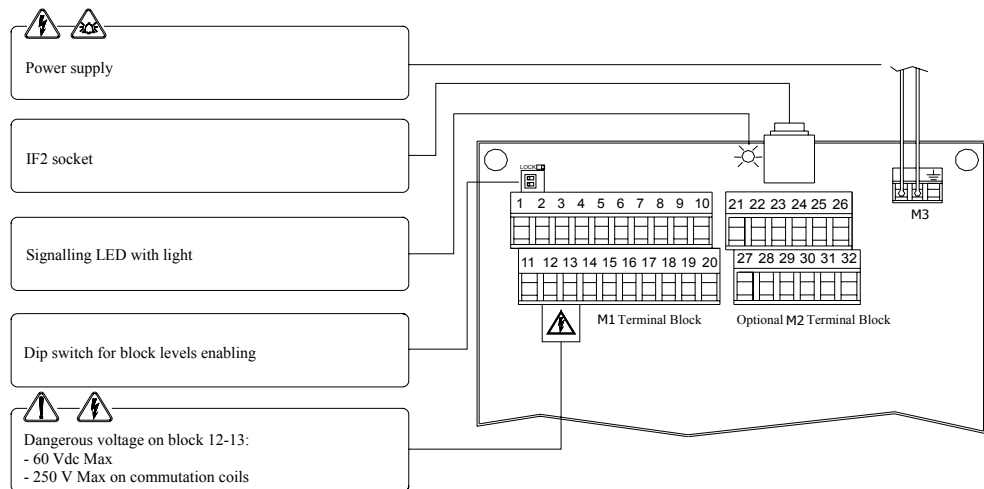

### Sensor cable

The terminals for the sensor cable connection are 1, 2, 3, 12 & 13 on Terminal Block M1. Connect the sensor cable wires using the color code table below.

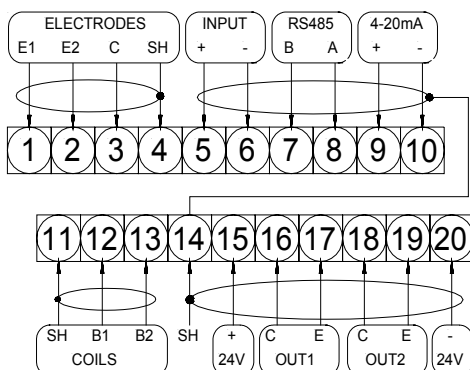

Terminal Assignment	Sensor Wiring Color Code
#1	Blue wire from the voltage-electrode cable
#2	White wire from the voltage-electrode cable
#3	Black wire from the voltage-electrode cable
#12	Red wire from the sensor coil cable
#13	Blue wire from the sensor coil cable

### 0/4 ~ 20/22 mA hookup

Isolated 0/4 ~ 20/22 mA current loops are used to output flow data to external devices. Maximum load impedance is 1,000-Ohms, and the maximum voltage without load is 27VDC. The converter has the capability to detect a loss of load on this output. To disable this function set the value “mA Val. Fault” (Pos. 4.7) under the ALARMS menu to zero.

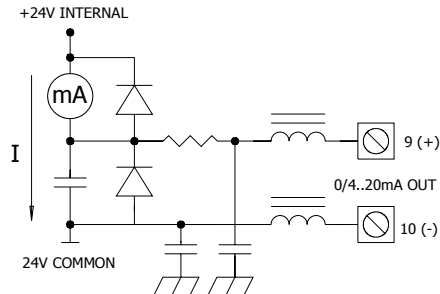

If the external device requires a voltage input, a precision resistor placed across the input terminals of the external device will change the current to voltage. Calculate the required resistor using ohms law ( $V = I \times R$ ). For example, a 250 ohm resistor will provide an input voltage of one to five volts with the transmitter range being set from 4mA to 20mA.

$$\frac{5V}{0.020A} = 250\Omega$$

$$\frac{1V}{0.004A} = 250\Omega$$

$$\frac{V}{I} = R \quad \frac{\text{volts}}{\text{amps}} = \text{ohms}$$

\* An additional 4 to20 ma loop output is available

### Opto-isolated pulse output hookup

The two pulse outputs are transistor outputs used to activate external devices when the flow reaches a predetermined set point.

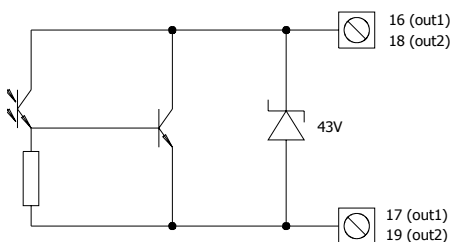

- Opto-isolated output with collector and emitter terminals floating and freely connectable
- Maximum switching voltage: 40 Vdc
- Maximum switching current: 100mA
- Maximum saturation voltage between collector and emitter @100mA: 1,2V
- Maximum switching frequency (load on the collector or emitter,  $R_L=470\Omega$ ,  $V_{OUT}=24V_{dc}$ ): 1250Hz
- Maximum reverse current bearable on the input during and accidental polarity reversion (VEC): 100mA
- Insulation from other secondary circuits: 500 V

## Converter power hookup

### WARNING!!

**Hazardous supply voltage can shock, burn, or cause death.**

The power supply line must be equipped with external surge protection for current overload (fuse or circuit breaker with limiting capacity not greater than 10 A). It must be easily accessible for the operator and clearly identified.

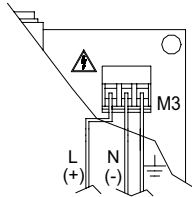

Power connection is made using the power terminal block M3 on the upper right side of the terminal board. Connect earth ground to the protective grounding terminal before making other connections. The power supply of a standard converter is 90-265 VAC, 44-60Hz at maximum 20W. DC converter is available as an option

## Digital Input hookup

The input functions can be divided into three groups:

1. Only assignable functions to input 1.
2. Functions that act directly on the inputs independently from the selected input.
3. Only assignable functions to input 1 and only to input 2, which have interactions between them.

### External power supply

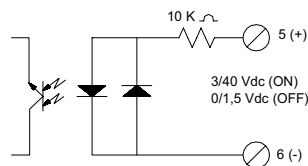

### Internal power supply

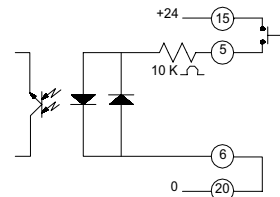

Remember that activation of any batch function automatically disable the other functions listed below.

		POS 12.5	POS 12.6	POS 5.6	POS 12.1	POS 5.9	POS 3.7-5.8	POS 3.8	POS 5.7
* IF USED ON INPUT 1 ** VALUE TO ZERO									
	AUTO BATCH								
	BM AUTO SEL								
	BLOCK TOTALIZER								
	N. SAMPLES								
	INPUT 1 ON START/STOP BATCH								
	AUTO RANGE CHANGE OR FROM INPUT								
	ENERGY SAVING								
	CALIBRATION								
POS 12.5	AUTO BATCH			*DISABLE					
POS 12.6	BM AUTO SEL				** DISABLE				
POS 12.7	CONS. MODE	DISABLE	DISABLE	* DISABLE					
POS 5.9	INPUT 1 ON START/STOP BATCH						DISABLE	DISABLE	DISABLE
POS 5.10	INPUT 2 ON START/STOP BATCH					DISABLE	DISABLE	DISABLE	DISABLE
POS 5.10	BM SELECT		DISABLE		** DISABLE				
POS 6.1-6.4	OUTPUT ON END BATCH							DISABLE	

Acts on



## INPUT OPERATION STAGE (GENERIC FUNCTIONS)

### Converter calibration

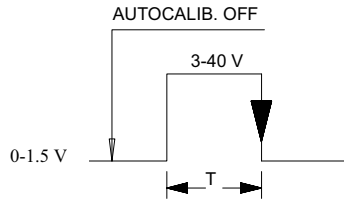

$T_{min} < T < 1 \text{ sec.} = \text{autocalibration}$   
 $T > 1 \text{ sec.} = \text{Auto zero}$

#### Necessary conditions for enabling the function

POS. 5.7 ENABLED  
 POS. 5.9 (batch on input 1) DISABLED  
 POS. 5.10 batch functions assign to input 2 (optional) DISABLED  
 \*Not for calibrating the entire meter

### Reset totalizes

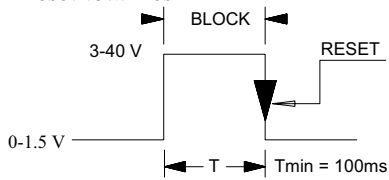

#### Necessary conditions for enabling the function

POS. 5.1 ÷ 5.4 ENABLED at least one  
 N.B.: This function is even assignable to the optional Input 2

### Block totalizes

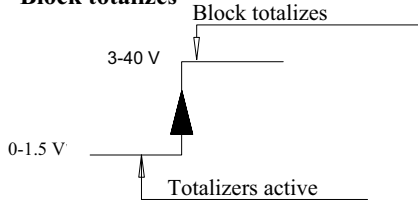

#### Necessary conditions for enabling the function

POS. 5.6 ENABLED  
 POS. 12.5 (auto-batch) DISABLED  
 POS. 12.7 (batch consent) DISABLED

### Range change

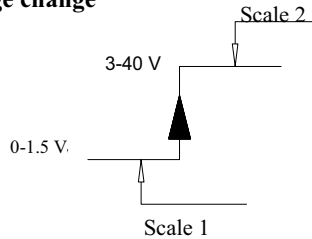

#### Necessary conditions for enabling the function

POS. 5.8 ENABLE  
 POS. 5.9 (batch on input 1) DISABLED  
 POS. 5.10 batch functions assign to optional Input 2 DISABLED  
 POS. 6.1-6.4 end-batch functions assign to output 2 1 e/o 2 DISABLED

### Speed rate

### Tmin

10 Hz	220 ms
20 Hz	110 ms
50 Hz	45 ms
80 Hz	30 ms
150 Hz	15 ms



ATTENTION: time T must be  $\geq$  to  $T_{min}$



NOTE: THE FUNCTIONS ABOVE INDICATED ARE ENABLED ONLY ON INPUT 1

## ADVANCED USER OPTION OPERATION STAGE ON INPUT 1 OR 2 (BATCH FUNCTION)

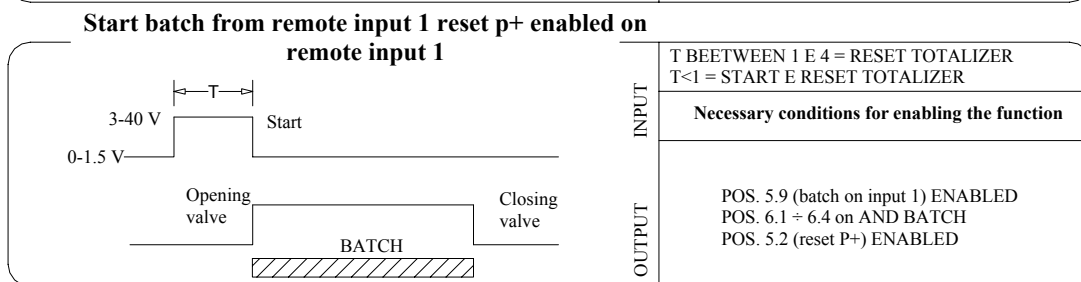
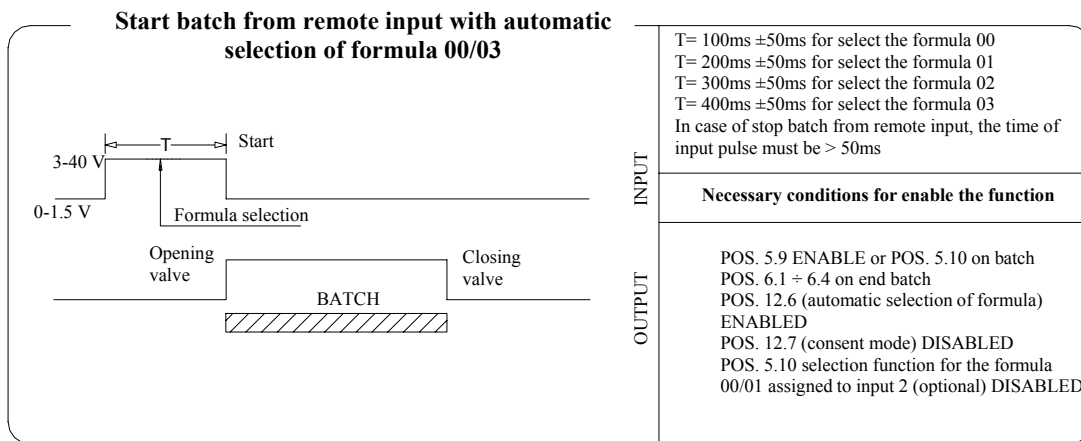
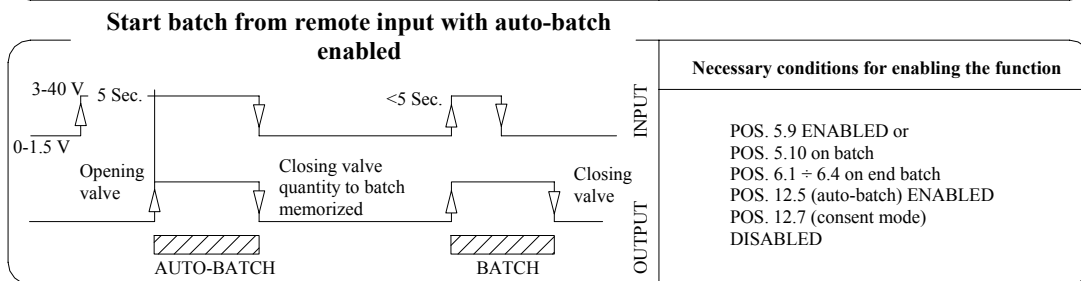
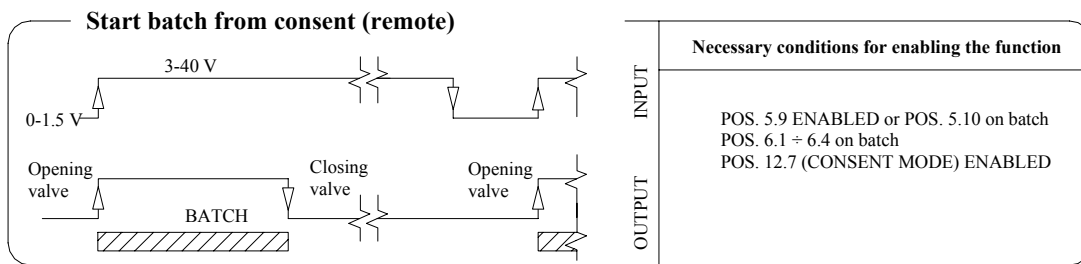
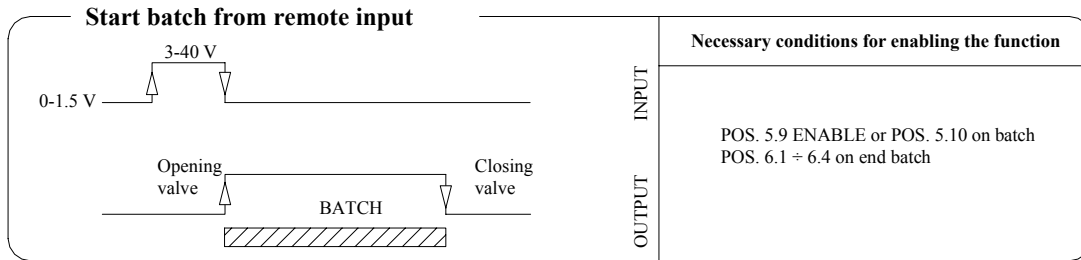

**NOTE: THE ACTIVATION OF BATCH FUNCTIONS ON INPUT 2 PREVENTS THE ACTIVATION OF BATCH FUNCTIONS ON INPUT 1**

## ADVANCED USER OPTION OPERATION STAGE ON INPUT 1 AND 2 (BATCH FUNCTION)

### Start batch on remote input 1 stop from output selection formula 00 to 01 from remote input 2

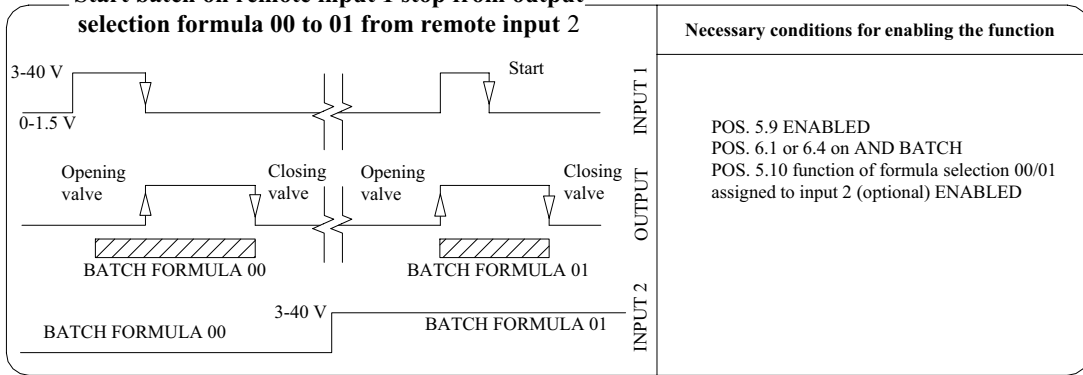

**Necessary conditions for enabling the function**

POS. 5.9 ENABLED  
POS. 6.1 or 6.4 on AND BATCH  
POS. 5.10 function of formula selection 00/01 assigned to input 2 (optional) ENABLED

### Block totalizer from remote input 1 start batch from remote input 2

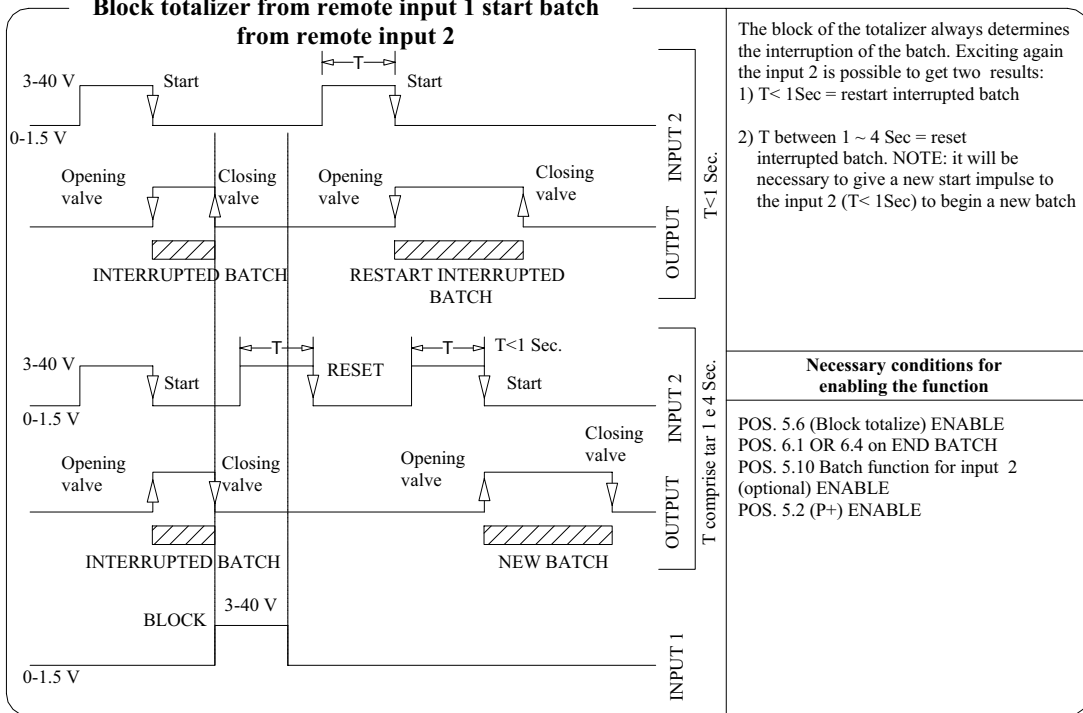

The block of the totalizer always determines the interruption of the batch. Exciting again the input 2 is possible to get two results:

- 1)  $T < 1 \text{ Sec}$  = restart interrupted batch
- 2)  $T$  between 1 ~ 4 Sec = reset interrupted batch. NOTE: it will be necessary to give a new start impulse to the input 2 ( $T < 1 \text{ Sec}$ ) to begin a new batch

**Necessary conditions for enabling the function**

POS. 5.6 (Block totalize) ENABLE  
POS. 6.1 OR 6.4 on END BATCH  
POS. 5.10 Batch function for input 2 (optional) ENABLE  
POS. 5.2 (P+) ENABLE

### Block and reset totalize from remote input 1 start batch from remote input 2 consent mode to batch enable

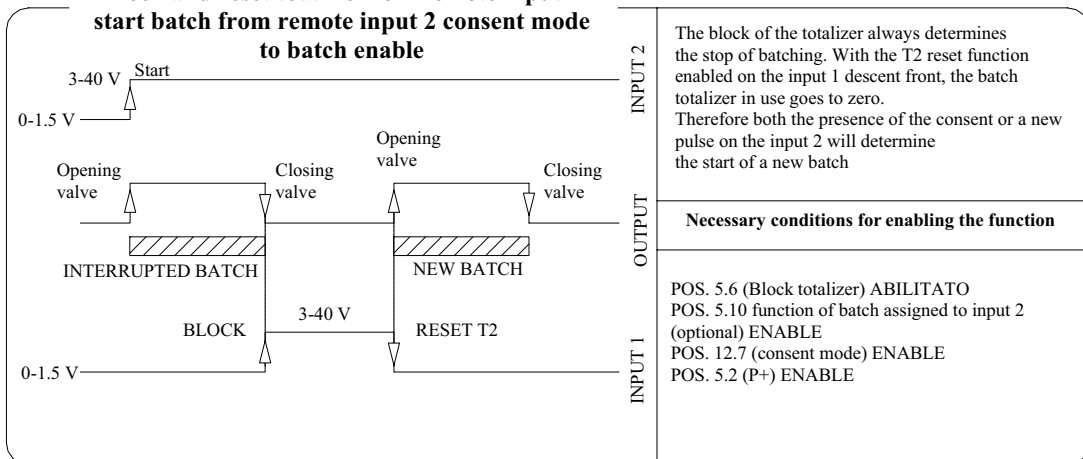

The block of the totalizer always determines the stop of batching. With the T2 reset function enabled on the input 1 descent front, the batch totalizer in use goes to zero. Therefore both the presence of the consent or a new pulse on the input 2 will determine the start of a new batch

**Necessary conditions for enabling the function**

POS. 5.6 (Block totalizer) ABILITATO  
POS. 5.10 function of batch assigned to input 2 (optional) ENABLE  
POS. 12.7 (consent mode) ENABLE  
POS. 5.2 (P+) ENABLE

### ***Instrument start-up***

Before starting up the instrument please verify the following:

- Power supply voltage must correspond to that specified on the name plate
- Electric connections must be wired as described in this manual
- Ground connections must be properly installed

When the instrument is powered, if the converter exhibits different operating conditions from the last shutdown, it initiates a verification cycle of the converter while displaying an incrementing diagnostic number from 0 through 90. When the diagnostic is complete an error number will be displayed referencing the chart at the back of this manual. A text message will also be displayed on the alarm screen (to view alarms, press the UP arrow key from the main display screen)

# Setting up the Model 284

---

After the Multi-Mag™ sensor is installed, and all of the connections have been made, the Model 284 has to be set up for the installation site.

The programming of the meter is performed using the keypad:

## UP and DOWN ARROW KEYS



### SHORT PRESSING (< 1 SECOND):

It increases the numeric figure or the parameter selected by the cursor  
It goes to the previous subject on the menu  
Batch start/stop (when enabled)



### LONG PRESSING (> 1 SECOND):

It decreases the numeric figure or the parameter selected by the cursor

## RIGHT and LEFT ARROW KEYS

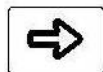

### SHORT PRESSING (< 1 SECOND):

It moves the cursor rightward on the input field  
It goes to the following subject of the menu  
It changes the display of the process data



### LONG PRESSING (> 1 SECOND):

It moves the cursor leftward on the input field  
It goes to the previous subject on the menu

## ENTER and EXIT KEYS



### SHORT PRESSING (< 1 SECOND):

It enters/leaves the selected function  
It enables the main menu for the instrument configuration  
It cancels the selected function under progress



### LONG PRESSING (> 1 SECOND):

It leaves the current menu  
It enables the totalise reset request (when enabled)  
It confirms the selected function

# Front panel display

Short-press the right-arrow key to view different visualization pages.

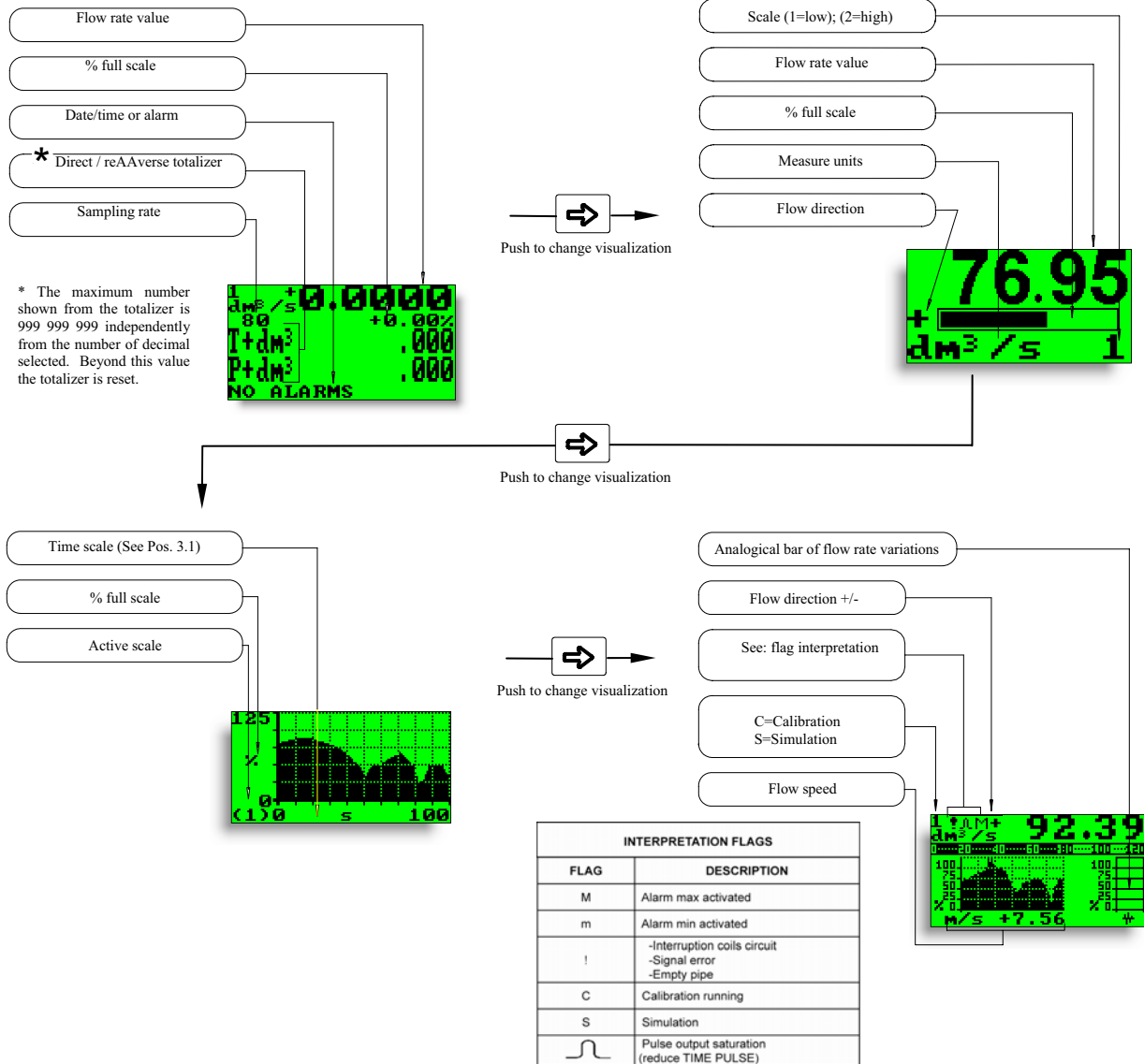

## With CURRENCY FUNCTION enabled

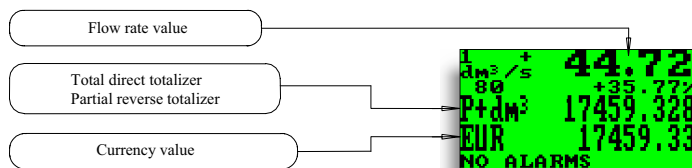

NOTE: the visualization of the pages can be changed respect to some functions enable or disabled (POS. 8.4~8.10 and batch functions)

# Factory pre-setting

## Access codes

The converter is delivered with access code L2 (Menu “11-Internal data” POS. 11.1) = 00002, and with the “Quick start menu” enabled. Press the key  to access to the “Quick start menu”, and the functions within can be set without entering any access code. The “Quick start menu” is enabled by POS. 8.6 function from the Menu “8-Display”.

With access code L2 = 00000, the request of the code is disabled. With access code L2 customized\*, one can proceed with programming all functions up to L2 security level by entering the code itself whenever entering the Main menu is required.

**\*ATTENTION:** take note very carefully of the customized code you have chosen, since there is no way to retrieve it if forgotten.

## Block levels

The block level enables or disables the access to the functions of the converter. The available levels of block are as described below (Menu “11-Internal data” POS. 11.2):

- Level 0: it completely disables the access to the main functions. The following functions can be performed through the keyboard:
  - Changing the display mode
  - Dosing start/stop
  - Data printing
- Level 1: it enables the access to the following functions:
  - Totalizer resetting
  - Dosing functions modifications
- Level 2: it enables the access to the following functions:
  - Quick start menu
  - Scale (full enabling)
  - Display (partial enabling)
  - Diagnostics (partial enabling)
- Level 3: it enables the access to all the functions of Level 2

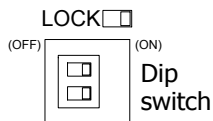

The converter is delivered with the block level of Level 3. If for several reasons the block level change is required, follow the steps:

1. Set the dip switch to OFF position
2. Access to the function “Lock level” of the Menu “11-Internal data”
3. Choose the desired level of block
4. Place the DIP switch to ON to enable the selected block level



# Programming the converter

## Quick start menu

Press the keys  and  to toggle between the “Quick start menu” and the visualization pages. Follow the steps of the flow chart below to change the parameters in this menu.

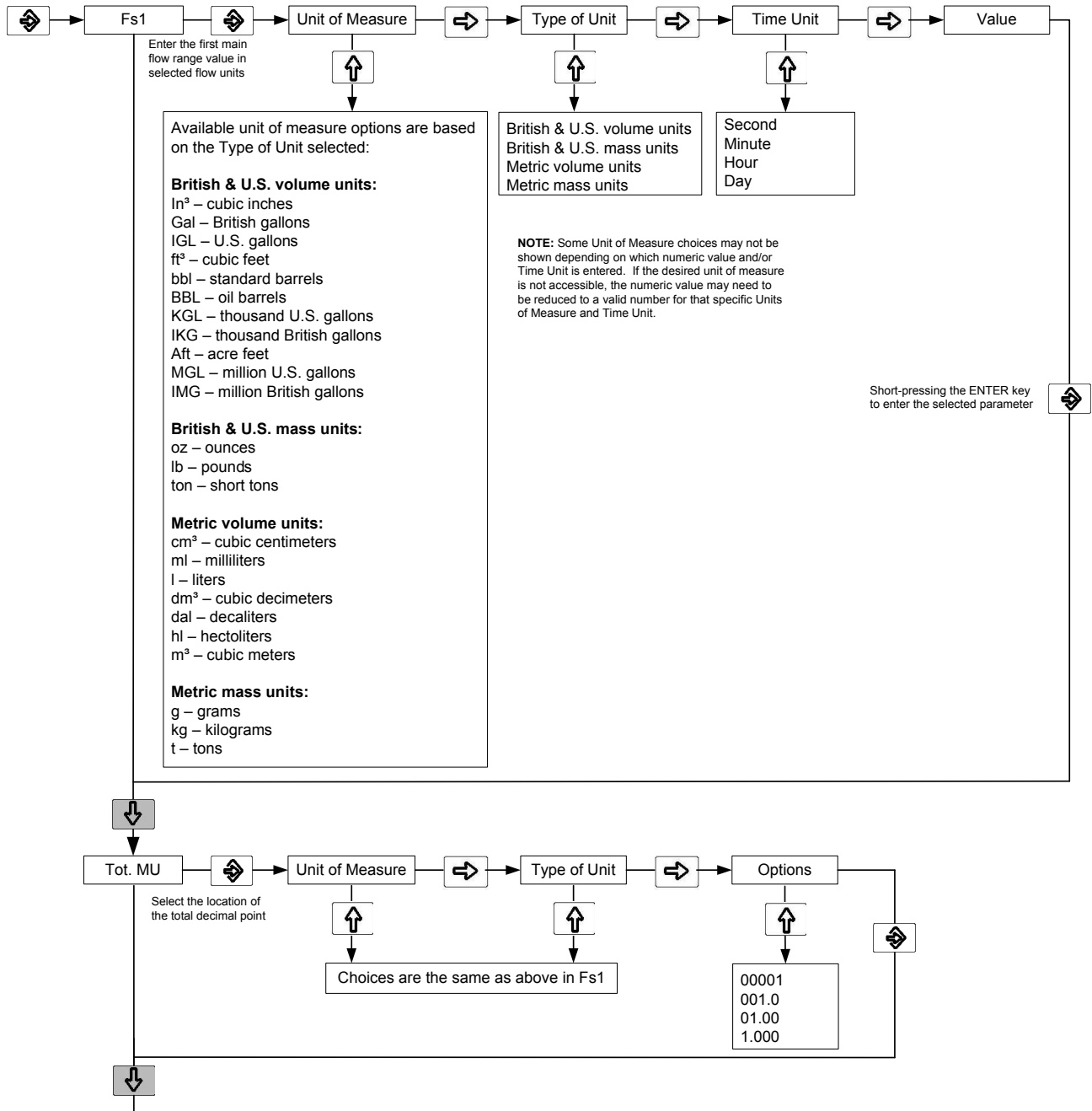



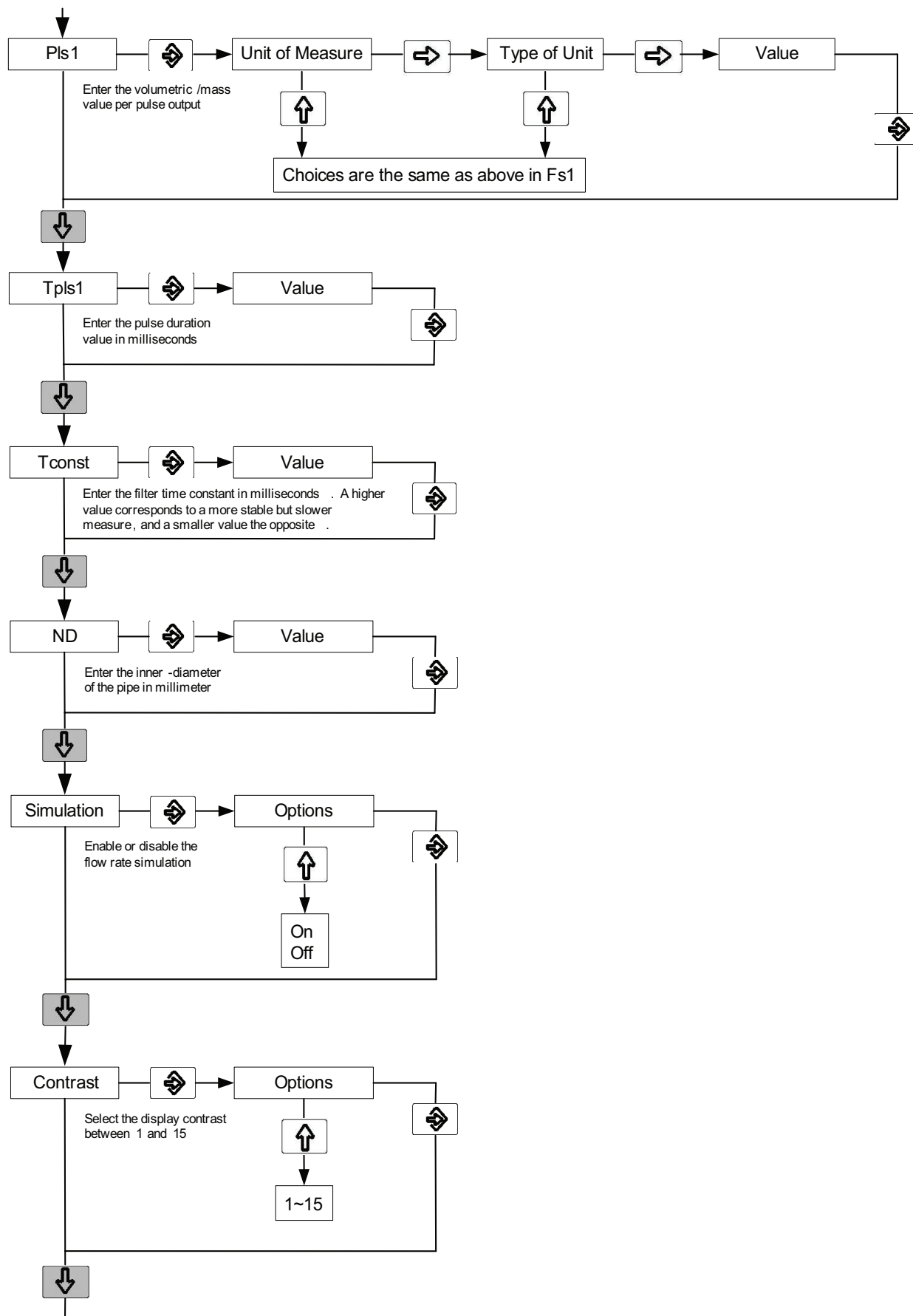

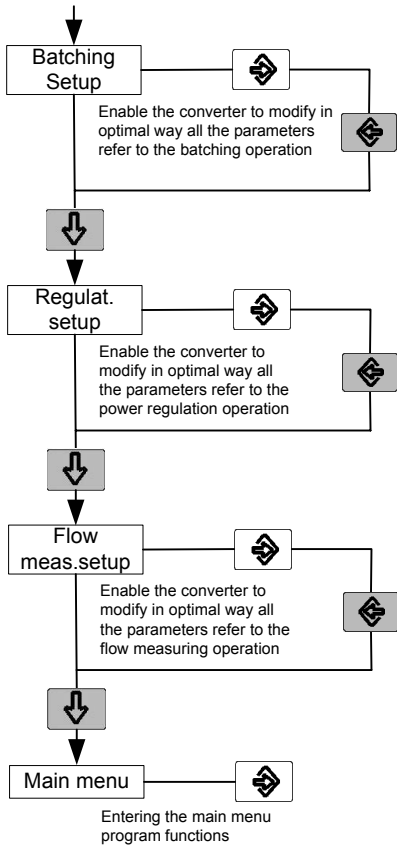

## Programming example

The steps below demonstrate how to modify the full scale value from 4dm<sup>3</sup>/s to 5dm<sup>3</sup>/s from the “Quick start men”

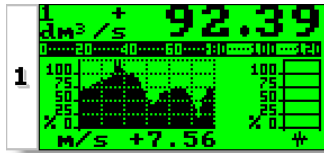

Enter in the “Quick start menu”

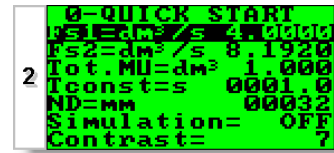

Access to the function “Fs1”

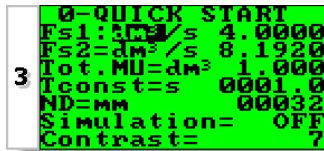

Push repeatedly

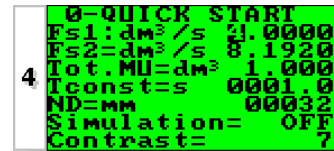

Change the value

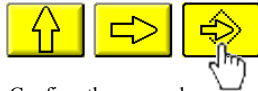
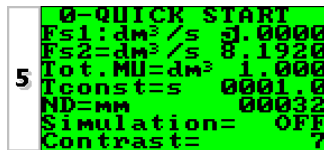

Confirm the new value with a short press

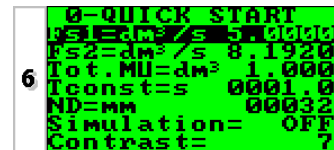

Long push to exit to the main visualization page

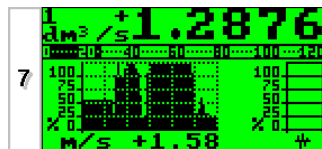



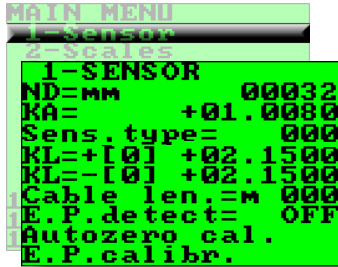

Main visualization page

## Main menu

Press the key  to go to the Main menu directly when the “Quick start menu” is disabled or select the Main menu from the “Quick start menu”. The functions in the Main menu are explained below. Please note that some functions are only displayed if other functions are enable or with the insertion of additional modules.



### Menu 1-Sensor

- POS 1.1 ND:** inner-diameter of the pipe in millimeter
- POS 1.2 KA:** factory-set gain factor
- POS 1.3 Sens.type:** meter serial number
- POS 1.4 KL+:** factory-set linearization points for forward flow
- POS 1.5 KL-:** factory-set linearization points for reverse flow
- POS 1.6 Cable len.:** lengths of cable in multiples of 10 meters
- POS 1.7 E.P.detect:** empty pipe detection enable or disable
- POS 1.8 Autozero cal.:** automatic zero calibration system execution. To perform this function, it is absolutely necessary to completely fill the pipe with liquid, and the liquid is perfectly staying still. Even very small amounts of movement of the liquid may affect the result of this function. When the percentage flow rate value is stable at zero, press the key . Check that the percentage flow rate value goes to zero, otherwise repeat the operation again. When the value is stable at zero, then press the key  to complete this calibration.
- POS 1.9 E.P.calibr.:** enabling of the automatic calibration of the empty pipe detection. Before performing this function, the pipe has to be completely filled with the liquid. The pipe has then to be emptied again, and then you should press the key . The operation will have to confirmed by pressing the key . By this function, the system sets the value of the empty pipe detection threshold (POS 4.6 “E.p.thr.” value in the menu “4-Alarms”).

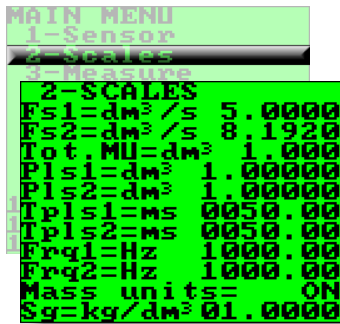

## Menu 2-Scales

- POS 2.1 Fs1:** full scale flow range
- POS 2.2 Fs2:** second full scale flow range. This function appears when the POS 3.7 “Autorange” in the menu “3-Measure” is enabled.
- POS 2.3 Tot.MU:** location of the totalizer decimal point
- POS 2.4 Pls1:** amount of volume or mass per pulse for output channel 1.
- POS 2.5 Pls2:** amount of volume or mass per pulse for output channel 2. This function appears when POS 6.2 “Out2” in the menu “6-Outputs” is selected to have a pulse output on output channel 2.
- POS 2.6 Tpls1:** pulse duration generated on output channel 1.
- POS 2.7 Tpls2:** pulse duration generated on output channel 2. This function appears when POS 6.2 “Out2” in the menu “6-Outputs” is selected to have a pulse output on output channel 2.
- POS 2.8 Frq1:** full scale frequency (0.1Hz~1000.0Hz) for output channel 1. This function appears when POS 6.1 “Out1” in the menu “6-Outputs” is selected to have a frequency output on output channel 1.
- POS 2.9 Frq2:** full scale frequency (0.1Hz~1000.0Hz) for output channel 2. This function appears when POS 6.2 “Out2” in the menu “6-Outputs” is selected to have a frequency output on output channel 2.
- POS 2.10 Mass units:** enabling/disabling of the selection of mass units on full scale set
- POS 2.11 Sg:** specific gravity set in kg/dm<sup>3</sup>. This function appears when a mass unit of measure is selected for the full scale.

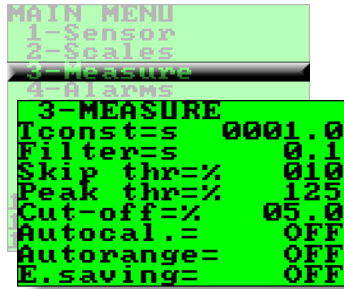

### Menu 3-Measures

**CAUTION! All parameters in this menu are set at the factory for the optimal performance of the meter. Modifying any value without proper cognition may decrease the meter's performance.**

- POS 3.1 **Tconst:** measuring time constant in seconds (Default = 5s).
- POS 3.2 **Filter:** filter on the power supply in seconds. 0.1s = “ready” measure and 0.5s = filter of noise on the liquid (Default = 0.1s).
- POS 3.3 **Skip thr:** acceleration threshold in percentage of full scale. The acceleration threshold stands for the limit beyond which a flow rate variation determines an immediate response at the output, without being filtered by the time constant (Default = 25%).
- POS 3.4 **Peak thr:** anomalous signal peak cut off threshold in percentage of full scale. This parameter allows setting the maximum value of deviation of the actual measure sample by comparison with the average one. If the new value is higher than the set limit, then such a value is “cut” to the limit value. This function is used to make the meter less sensitive to big perturbations on the flow rate measure, as it may happen when there are solids in suspension in the liquid hitting against the electrodes determining a high electrical noise (Default = 50%).
- POS 3.5 **Cut-off:** flow velocity in percentage of full scale below which all output are set to zero (Default = 2%).
- POS 3.6 **Autocal.:** enabling/disabling of an internal calibration cycle every hour. The measure is stopped for 8~15 seconds.
- POS 3.7 **Autorange:** enabling/disabling automatic change of scale. When the flow rate increases and reaches the 100% of the full scale 1, then the meter automatically switches to scale 2. When the flow rate decreases again reaching a value on scale 2 equal to the 90% of full scale 1, then the active scale is 1 again.
- POS 3.8 **E.saving:** enabling/disabling of energy saving mode. It is recommended to use this function only when the instrument is powered by a battery or solar cells, allowing an energy saving up to 60~80%. This function enables the automatic control of the energy consumption by changing the ratio between the measuring cycles powering the coils and the cycles without powering the coils. When the flow rate is stable the number of “off” cycles is higher than the “on” ones, so that the average consumption is strongly reduced. If the flow rate suddenly changes, then the meter switches on a higher number of measuring cycles, in order to get a higher response time, switching off the cycles as soon as the flow rate gets back to being stable.

```

MAIN MENU
1-Sensor
2-Scales
3-Measure
4- Alarms
5-Units

4-ALARMS
Max thr+=% 000
Max thr-=% 000
Min thr+=% 000
Min thr-=% 000
Hyst.=% 03
E.p.thr.= 075
mA v.fault=% 000
Hz v.fault=% 125
Timeout=s 00.0

```

## Menu 4-Alarms

- POS 4.1 Max thr+:** maximum value alarm set in percentage of full scale for positive flow rate.
- POS 4.2 Max thr-:** maximum value alarm set in percentage of full scale for reverse flow rate.
- POS 4.3 Min thr+:** minimum value alarm set in percentage of full scale for positive flow rate.
- POS 4.4 Min thr-:** minimum value alarm set in percentage of full scale for reverse flow rate.
- POS 4.5 Hyst.:** hysteresis threshold set for the minimum and maximum flow rate alarms in percentage of full scale.
- POS 4.6 E.p.thr.:** factory-set empty pipe detection threshold. It is obtained by performing an empty pipe calibration.
- POS 4.7 mA v.fault:** current output value set in percentage in case of failure. The allowed range is from 0 to 120% of the 0..20 mA scale, 120% corresponds to 24 mA and does not depend on the selected range (0...20 / 4...20 mA). The default value is set at the 10%, so that the current value in case of the a.m. cases would be 2 mA, allowing the following diagnostics:
- current < 2 mA - 5%: line interrupted, power supply failure or faulty converter;
  - 2 mA -5% ≤ current ≤ 2 mA + 5%: hardware alarm;
  - 4 mA ≤ current ≤ 20 mA: normal working range;
  - 20 mA < current ≤ 22 mA: out of range, measure above 100% of the full scale
- POS 4.8 Timeout:** batch safety time set in seconds. This function is useful when you need control of one or both of the followings conditions:
- batch valve open and flow rate is zero
  - batch valve closed and flow rate is different than zero

When this alarm is activated, the batch operation is aborted and the power supply to the valve is disconnected. The values of function are from 0 to 25.5 seconds, and is active only if one or more of the batch functions are enabled.

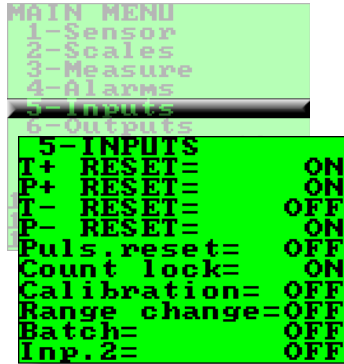

## Menu 5-Inputs

- POS 5.1 T+ RESET:** enabling/disabling of the forward flow totalizer reset.
- POS 5.2 P+ RESET:** enabling/disabling of the partial forward flow totalizer reset.
- POS 5.3 T- RESET:** enabling/disabling of the reverse flow totalizer reset.
- POS 5.4 P- RESET:** enabling/disabling of the partial reverse flow totalizer reset.
- POS 5.5 Puls.reset:** enabling/disabling of the pulse output totalizer reset from the digital input.
- POS 5.6 Count lock:** enabling/disabling of blocking the totalizer count from the digital input.
- POS 5.7 Calibration:** enabling/disabling of performing automatic calibration from the digital input. When this function is active, applying a voltage to the on/off input terminals the meter performs an autozero calibration cycle.  
**ATTENTION:** if the voltage pulse is less 1 sec., the meter performs a calibration cycle for compensating possible thermal drifts. If the voltage pulse is more 1 sec, the meter performs a zero calibration of measure.
- POS 5.8 Range change:** enabling/disabling of changing the full scale range from the digital input.
- POS 5.9 Batch:** enabling/disabling of batching start/stop from the digital input.
- POS 5.10 Inp.2:** functions assigned to input 2. This function only appears when the optional input module is installed.



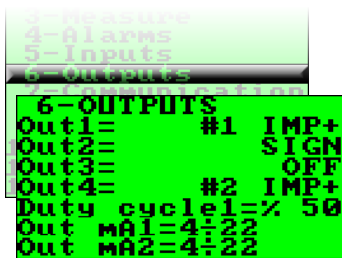

### Menu 6-Outputs

- POS 6.1 **Out1:** output 1 function assignment.
- POS 6.2 **Out2:** output 2 function assignment.
- POS 6.3 **Out3:** output 3 function assignment. This function only appears when the optional output module is installed.
- POS 6.4 **Out4:** output 4 function assignment. This function only appears when the optional output module is installed.

Choice of the functions corresponding to the outputs are listed in the table below.

Function Symbol	Function Explanation
#1 IMP+	Pulse on output 1 for forward flow rate
#1 IMP-	Pulse on output 1 for reverse flow rate
#1 IMP	Pulse on output 1 for forward and reverse flow rate
#2 IMP+	Pulse on output 2 for forward flow rate
#2 IMP-	Pulse on output 2 for reverse flow rate
#2 IMP	Pulse on output 2 for forward and reverse flow rate
#1 FREQ+	Frequency on output 1 for forward flow
#1 FREQ-	Frequency on output 1 for reverse flow
#1 FREQ	Frequency on output 1 for forward and reverse flow
#2 FREQ+	Frequency on output 2 for forward flow
#2 FREQ-	Frequency on output 2 for reverse flow
#2 FREQ	Frequency on output 2 for forward and reverse flow
SIGN	Flow direction output (energized = reverse flow)
RANGE	Range indication output (energized = full scale 2)
MAX AL+	Max. forward flow rate output (energized = alarm off)
MAX AL-	Max. reverse flow rate output (energized = alarm off)
MAX AL	Max. forward and reverse flow rate output (energized = alarm off)
MIN AL+	Min. forward flow rate output (energized = alarm off)
MIN AL-	Min. reverse flow rate output (energized = alarm off)
MIN AL	Min. forward and reverse flow rate output (energized = alarm off)
MAX+MIN	Max. and min. flow rate alarm output (energized = alarm off)
EMPTY PIPE	Empty pipe alarm output (energized = full pipe)
OVERFLOW	Out of range alarm output (energized = flow rate is in range)
Hardw AL.	Cumulative alarm output; interrupt coils, empty pipe, and or measure error (energized = alarms off)
BATCH AL	Batch alarm (energized = alarm off)
EXT. COMM.	Communication alarm. Only available with data logger module (energized = alarm off)
BATCH SYN	At the end of batch the output change status
END BATCH.	End batch output (energized = batch in progress)
PREBATCH.	Prebatch output (energized = prebatch in progress)

**POS 6.5 Duty cycle1:** duty cycle value for pulses/frequency output on output 1. This function only appears when the output 1 is assigned to have either a pulse or a frequency output.

**POS 6.6 Out mA1:** range of current output 1 and choices of the function.

**POS 6.7 Out mA2:** range of current output 2 and choices of the function. This function only appears when the additional 4-20mA module is installed.

CURRENT VALUES IN mA ASSOCIATE TO THE % VALUE OF FULL SCALE					
POSSIBLE FIELD	REVERSE FLOW VALUE		ZERO	DIRECT FLOW VALUE	
	$\leq -110\%$	-100%	0%	+100%	$\geq +110\%$
OutmA = 0 ÷ 20 +	0	0	0	20	20
OutmA = 0 ÷ 22 +	0	0	0	20	22
OutmA = 4 ÷ 20 +	4	4	4	20	20
OutmA = 4 ÷ 22 +	4	4	4	20	22
OutmA = 0 ÷ 20 -	20	20	0	0	0
OutmA = 0 ÷ 22 -	22	20	0	0	0
OutmA = 4 ÷ 20 -	20	20	4	4	4
OutmA = 4 ÷ 22 -	22	20	4	4	4
OutmA = 0 ÷ 20	20	20	0	20	20
OutmA = 0 ÷ 22	22	20	0	20	22
OutmA = 4 ÷ 20	20	20	4	20	20
OutmA = 4 ÷ 22	22	20	4	20	22
OutmA = 0 ÷ 20 -0+	0	0	10	20	20
OutmA = 0 ÷ 22 -0+	0	1	11	21	22
OutmA = 4 ÷ 20 -0+	4	4	12	20	20
OutmA = 4 ÷ 22 -0+	4	4.8	12.8	20.8	22

```
6-Outputs
7-Communication
7-COMMUNICATION
IF2 prot.= DPP
RS232 prot.= DPP
Address= 000
RS485 bps= 19200
RS232 bps= 4800
Printer= OFF
Print batch= OFF
Print data= OFF
Print events= OFF
Rem.addr.= 000
Remote u.conn.
```

## Menu 7-Communication

- POS 7.1 **IF2 prot.:** choice of communication protocol for the IF2 device (choices of DPP or HTP).
- POS 7.2 **RS232 prot.:** choice of communication protocol for the RS232 port (choices of DPP or HTP).
- POS 7.3 **Address:** address value of the converter (range 0~255)
- POS 7.4 **RS485 bps:** speed of the RS485 output (choices of 2400, 9600, 19200, and 38400 bps).
- POS 7.5 **RS232 bps:** speed of the RS232 output (choices of 2400, 9600, 19200, and 38400 bps).
- POS 7.6 **Printer:** enabling/disabling of print function via RS232. The print functions from POS 7.6~7.9 are optional.
- POS 7.7 **Print batch:** enabling/disabling of printing of the performed batch.
- POS 7.8 **Print data:** enabling/disabling of report print out at regular intervals.
- POS 7.9 **Rem.addr.:** address of a further converter connected like a terminal.
- POS 7.10 **Remote u.conn.:** start of remote connection to the terminal. Connection interrupted after 10 seconds of inactivity.

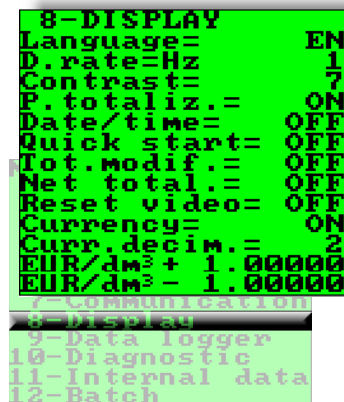

## Menu 8-Display

- POS 8.1 Language:** choices of the language: E = English, I = Italian, F = French, S = Spanish.
- POS 8.2 D.rate:** updating frequency of the display (choices of 1, 2, 5, and 10 Hz).
- POS 8.3 Contrast:** display contrast. This value can also be set from one of the display visualization pages by pushing the key  for 8 seconds or more. In this way, the contrast set will be visualized at release of the key.
- POS 8.4 P.totaliz.:** enabling/disabling of the partial totalizer visualization (this function is always on with batch enabled).
- POS 8.5 Date/time:** enabling/disabling of the date and time visualization with data logger enabled.
- POS 8.6 Quick start:** enabling/disabling of the Quick start menu visualization.
- POS 8.7 Tot.modif.:** enabling/disabling of the change value of the totalizers.
- POS 8.8 Net total.:** enabling/disabling of the visualization page of the net totalizer.
- POS 8.9 Reset video:** enabling/disabling of resetting the processor of the display.
- POS 8.10 Currency:** enabling/disabling of visualizing the values of the partial totalizer in the unit of selected currency
- POS 8.11 Curr.decim.:** choice of the numbers of decimals for the currency visualization value (ranges from 0 to 3).
- POS 8.12 EUR/dm<sup>3</sup>+::** value of the currency conversion factor for forward totalizer in the unit of currency/cubic decimeter. There are three set fields for this parameter, from left to right: monetary token, personalized monetary token, and conversion coefficient. For the selection, place the cursor over the field to modify. Choices of the predetermined monetary tokens are: EUR = Euro; USD = US dollar; CAD = Canadian dollar, AUD = Australian dollar; GBP = English pound, CHF = Swissfranc dollar, and JPY = Japanese yen.
- POS 8.13 EUR/dm<sup>3</sup>-:** value of the currency conversion factor for reverse totalizer in the unit of currency/cubic decimeter.

```

9-DATA LOGGER
1992/05/10 15:03
Acquisition= ON
Interval=h 24
Display data
Display events
Disp.min/max
Clear data
Clear events
Reset min/max

```

```

9-Data logger
10-Diagnostic
11-Internal data
12-Batch

```

### Menu 9-Data logger

- POS 9.1 **YYYY/MM/DD:** date and time set.
- POS 9.2 **Acquisition:** enabling/disabling of the automatic data logger.
- POS 9.3 **Interval:** interval time for the data logging function (choices of 1, 2, 3, 6, 8, 12, 24, and 48 hours).
- POS 9.4 **Display data:** displaying of the data stored in the data logger.
- POS 9.5 **Display events:** displaying of the last 64 alarms stored in the data logger.
- POS 9.6 **Disp.min/max:** displaying of minimum and maximum flow rates.
- POS 9.7 **Clear data:** reset all logged data.
- POS 9.8 **Clear events:** reset all logged alarm events.
- POS 9.9 **Reset min/max:** reset all logged minimum and maximum flow rates.

```

10-DIAGNOSTIC
Calibration
Self test
Simulation= OFF





```

```

9-Data logger
10-Diagnostic
11-Internal data
12-Batch

```

### Menu 10-Diagnostic

- POS 10.1 **Calibration:** enabling the automatic calibration of the converter.
- POS 10.2 **Self test:** enabling the converter autotest. This function stops the normal functions of the meter and performs a complete test cycle on the measure input circuits and on the excitation generator. This function is automatically performed when switching on the device.
- POS 10.3 **Simulation:** enabling flow rate simulation. With this function, it is possible to generate an internal signal that simulates the flow rate, allowing the output and all the connected instruments to be tested. After enabling it, the flow rate simulation can be:
  - 1) set by pushing the key  from one of visualization pages
  - 2) started by pushing the key  after setting it
  - 3) finished by pushing the key  from visualization pages and then by pushing the key .

```

11-INTERNAL DATA
L2 keycode=00000
Lock level= 3
Load fact.pres.
Load user pres.
Save user pres.
Hours= 000077
Ign.cal.err= OFF
KS= +1.0000
10-Diagnostic
11-Internal data
12-Batch

```

### Menu 11-Internal data

- POS 11.1 **L2 keycode:** level 2 access code enter.
- POS 11.2 **Lock level:** block level function set (ranges from 0~3).
- POS 11.3 **Load fact.pres.:** load factory data pre-set.
- POS 11.4 **Load user pres.:** load user data saved.
- POS 11.5 **Save user pres.:** save user data.
- POS 11.6 **Hours:** visualization of the total operation hours of the converter.
- POS 11.7 **Ign.cal.err:** ignore the calibration error during the converter switch-on automatic test
- POS 11.8 **KS:** Ks coefficient

```

12-BATCH
N.samples= 000
Diff.thr=% 010
V.com=dm3 00.000
V.pre=dm3 00.000
Auto batch= OFF
BM auto sel= OFF
Cons.mode= OFF
8-Display
9-Data logger
10-Diagnostic
11-Internal data
12-Batch

```

### Menu 12-Batch (Advanced User Option)

- POS 12.1 **N.to samples:** number of batch cycles to be done to define the value of compensation. This function automatically determines the average value for automatic compensation of system delay. Set to zero for manual introduction of the compensation value.
- POS 12.2 **Diff.thr:** this value defines the percentage of maximum difference between the compensation value set POS 12.3 and the average compensation value defined with the function POS 12.1. Over this threshold the new compensation value will be automatically set if the number of batch samples is different from zero.
- POS 12.3 **V.com:** this value, expressed in the same selected volume unit of measure, is the result of the difference between the batch value set and the quantity of product really supplied due to the system delays, such as closing valves, stopping pumps, stopping motors, etc.  
**ATTENTION:** if manually setting the value of compensation is required. Preset to zero for the number of batch samples.
- POS 12.4 **V.pre:** sets the volume of liquid at which you want to enable the pre-batch. When the pre-batch volume “V.Pre” is reached, the output is deactivated. This value is constant for all quantities to be batched and must be set in current volume unit of measure. The pre-batch function is useful when fast and accurate fillings are needed.

**POS 12.5 Auto batch:** enabling/disabling of the automatic batching function. With this function enabled, when applying a voltage on the digital input for more than 5 seconds, the valve controlled by the meter opens and stays open while the voltage is applied. When the product has reached the desired volume/level, removing the voltage from the input, then the meter closes the valve and memorizes the supplied product volume in the current memory batch. The value obtained with this procedure will be the volume supplied in every following batch. In order to modify this value, repeat the operations above. This procedure sets the safety timer at a value 1.25 times greater than the time used to reach the batched quantity; after that, the counter will be reset.

**POS 12.6 BM auto sel:** this function allows the automatic selection of the first four formulas depending on the duration of the pulse of the batch start. This function is active only if the function POS 12.7 “Cons.mode” has not been enabled. In addition, by activating this function, the automatic compensation of the batch value is excluded. However, the manual compensation is possible by introducing the opportune value on the parameter POS 12.3 “V.com”.

**POS 12.7 Cons.mode:** this function enables the start and the stop of the dosing using a static signal, instead of an impulsive, applied to the input. This signal will have to stay applied all through the batch. This function automatically disables the function POS 12.6 “BM auto sel” and POS 12.5 “Auto batch”.

**ADVANCED USER OPTION  
BATCH FUNCTION.**

**ENABLE BATCH**

Enable one of the following functions to enable and program the batch on the converter:

- POS. 5.9-5.10: START/STOP batch from input
- POS. 6.1-6.2: assign one of the functions to one of two output

Some examples of operation of such functions are visualized from page 11

**VISUALIZATION PAGE WITH BATCH FUNCTION ENABLE**

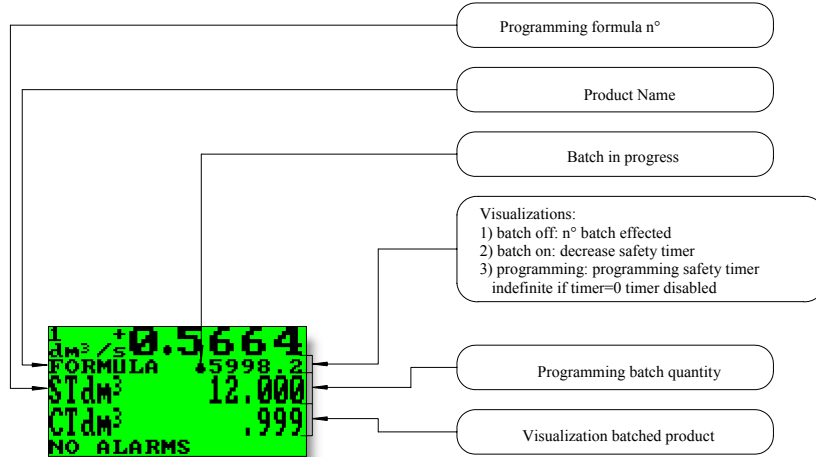

From the visualization pages

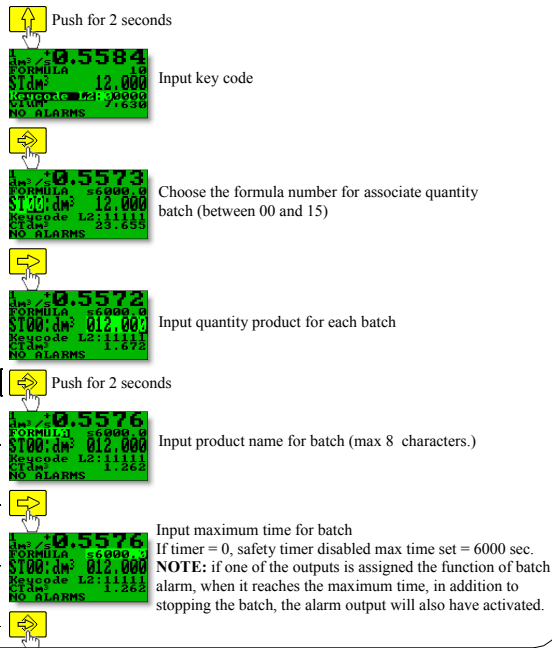

**PROGRAMMING BATCH**

For each formula you can associate:

- Product quantity
- Product name
- Maximum time for batch (safety time for each formula)

After activating the batch function from visualization page at pages 47, proceed as in the aside example.



## START STOP BATCH



**START:** it is possible activate the start of batch in two different ways:

1. **from remote input:** assigning the functions of start/stop batch to the input 1 (POS. 5.9) or input 2 (POS. 5.10) and using the input/s like visualized from page 12.
2. **from keyboard:** short pressing of the key   
**N.B.:** the start of batch from keyboard is always on the descent front (release of the key) and is not available with the function of batch consent (POS. 12.7)

**STOP:** the stop of batch can be due to three events:

1. **keyboard or remote input** (manual stop): short pressing of the key
2. **end of batch:** in this case the stop of batch will have been activated from an output signal to the attainment of the batch quantity
3. **maximum time of batch:** if a maximum batch time has been set and this is exceeded, the batch in progress is stopped independently from the batched quantity

**Notes:**

- during the batch the symbol of the active batch  and the name of the formula are visualized on video.
- When the batch outputs are enable, pushing for more of 5 sec. the key , the outpts will remain energized till the key is released. On the display, in place of the CT and ST totalisers the following messages will appear:  
!! VALVE !!  
!! OPENED !!

## Alarm messages

During meter setup, you may see error messages and codes. These messages and codes are explained below.

Messages	ANOMALIES	ACTION TO TAKE
<b>NO ALARMS</b>	All works regularly	----
<b>MAX ALARM</b>	The flow rate is higher than the maximum threshold set	Check the maximum flow rate threshold set and the process conditions
<b>MIN ALARM</b>	The flow rate is lower than the minimum threshold set	Check the minimum flow rate threshold set and the process conditions
<b>FLOW RATE &gt;FS</b>	The flow rate is higher than the full scale value set on the instrument	Check the full scale value set on the instrument and the process conditions
<b>PULSE/FREQ&gt;FS</b>	The pulse generation output of the device is saturated and cannot generate the sufficient number of impulses	Set a bigger unit of volume or, if the connected counting device allows it, reduce the pulse duration value
<b>EMPTY PIPE</b>	The measuring pipe is empty or the detection system has not been properly calibrated	Check whether the pipe is empty or perform again the empty pipe calibration procedure
<b>BATCH ALARM</b>	Batch interrupted for the followings condition: <input type="checkbox"/> Timer batch expired before the end of the batch <input type="checkbox"/> Batch valve open and flow rate to zero for a time longer to the safety timer set <input type="checkbox"/> Batch valve closed and flow rate different from zero for a time longer to the safety timer set	Verify: <input type="checkbox"/> Presetting <input type="checkbox"/> System condition
<b>INPUT NOISY</b>	The measure is strongly effected by external noise or the cable connected the converter to the sensor is broken	Check the status of the cables connecting the sensor, the grounding connections of the devices or the possible presence of noise sources
<b>EXCITATION FAIL</b>	The coils or the cable connecting the sensor are interrupted	Check the connecting cables to the sensor
<b>CURR. LOOP OPEN</b>	The 0/4...20mA output on board or the optional one are not correctly closed on a valid load	Verify the load is applied to the output (max 1000 ohm). To disable the alarm, set the "mA VAL.FAULT" value ( menu alarm ) to 0.
<b>P.SUPPLY FAIL</b>	Power supply different from that indicated on the label.	Verify that the power supply is that indicated on the label

CODES	ANOMALIE DESCRIPTIONS	ACTION TO TAKE
0001	<b>problem with watch-dog circuit</b>	ADDRESS TO SERVICE
0002	wrong configuration work data in eeprom	
0004	wrong configuration safety data in eeprom	
0008	defective eeprom	
0010	defective keyboard (one or more key are pushed during the test)	
0020	Power supply voltage (+3.3) is out of range	
0040	Power supply voltage (+13) is too low (<10V)	
0080	Power supply voltage (+13) it's too high (>14V)	
0200	timeout calibration input (input circuit is broken)	
0400	Gain input stage is out of range	
0800	Interruption on the coils circuit	Check the status of the cables connecting the sensor to the converter
0C00	Cumulative alarm 0800 + 0400	see single code

# Appendix - Application Schematics

The purpose of the application schematics is to show different applications and the best sensor location for a particular application.

## Clearance

Because the sensor will protrude from the pipe when installed, a clearance of at least one sensor length plus 12 inches should be allowed.

## Skewed profiles

The sensor may not operate within specifications in a location where the profile is skewed. These locations are indicated by an ESTIMATED ERROR notation in the application schematics. Errors are estimated for flow at  $\pm 10$  ft/sec. *If the velocity is less than  $\pm 10$  ft/sec, the error will be less.*

To avoid velocity "hot" or "cold" spots, choose an insertion angle which is away from the hot spot.

Distance **H** must be at least one sensor length plus 12 inches.

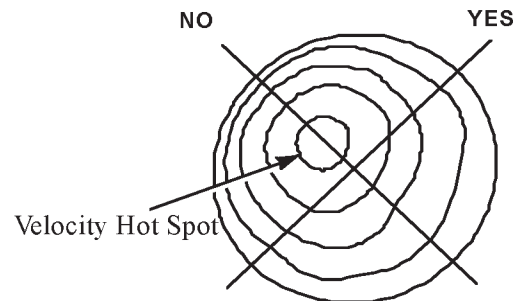
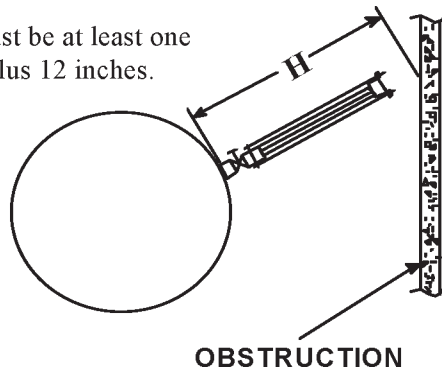

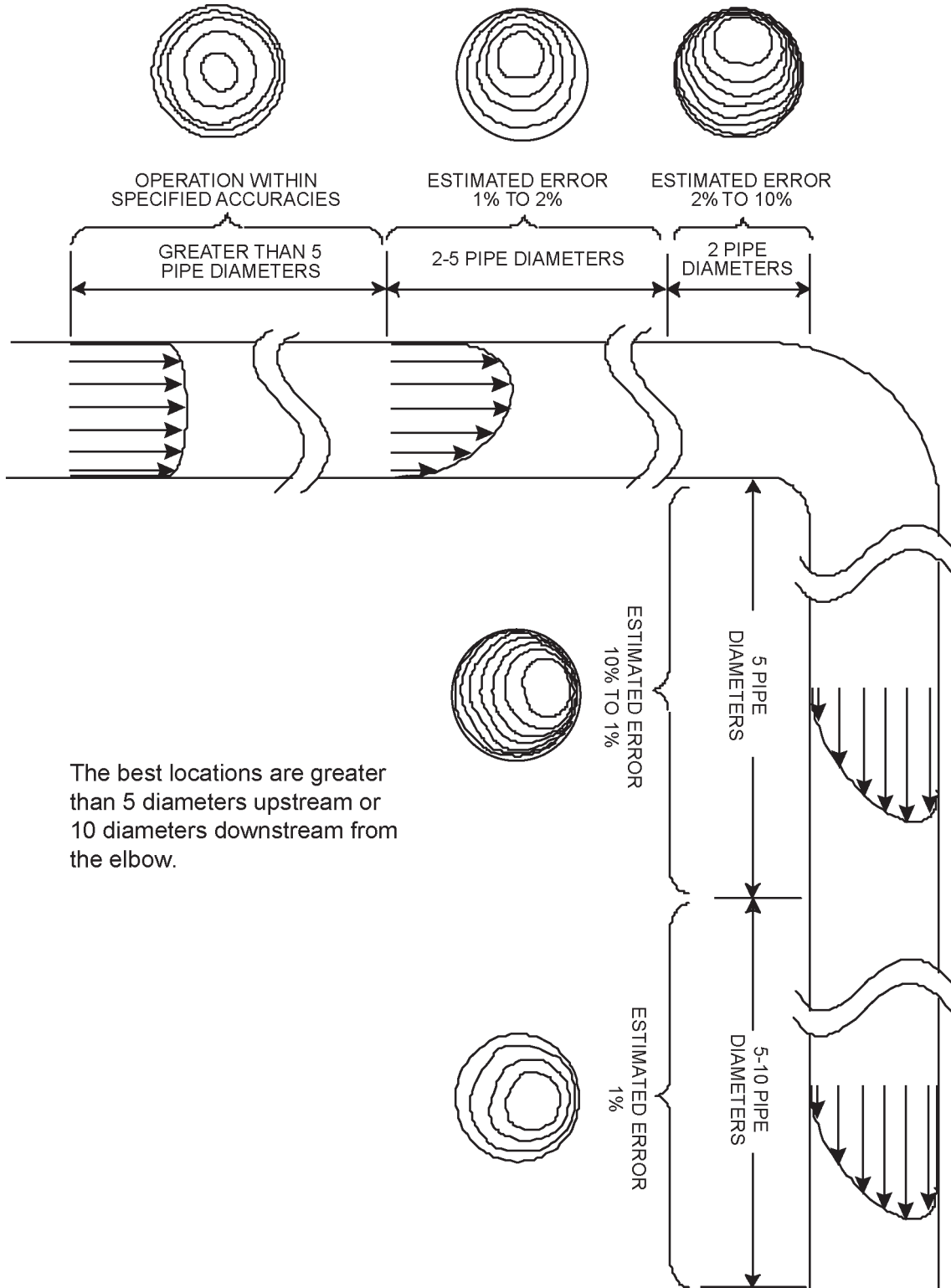

## 90° Elbow

*(errors are estimated for flow at 10 ft/sec)*

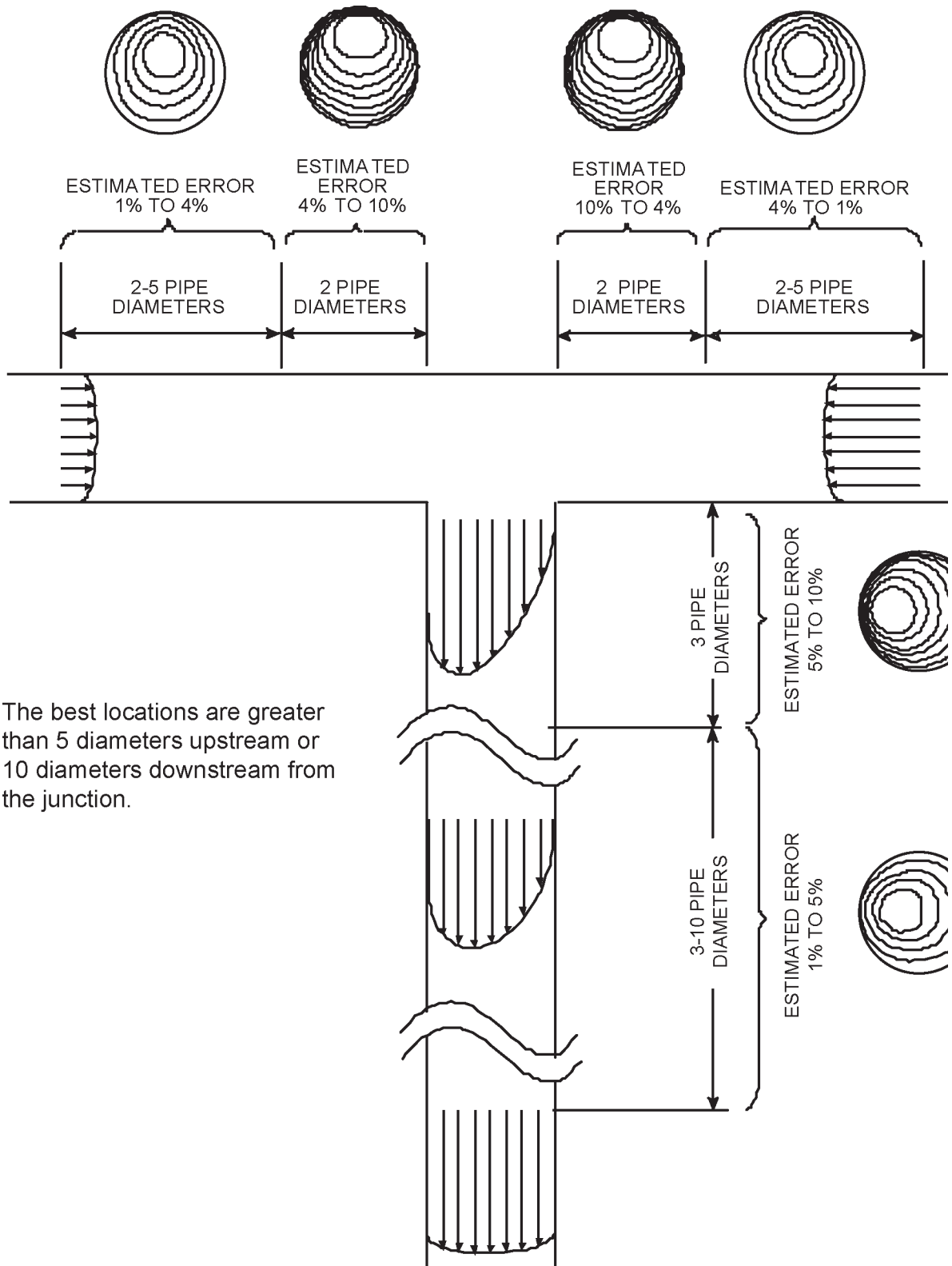

The best locations are greater than 5 diameters upstream or 10 diameters downstream from the junction.

## T-Junction

*(errors are estimated for flow at 10 ft/sec)*

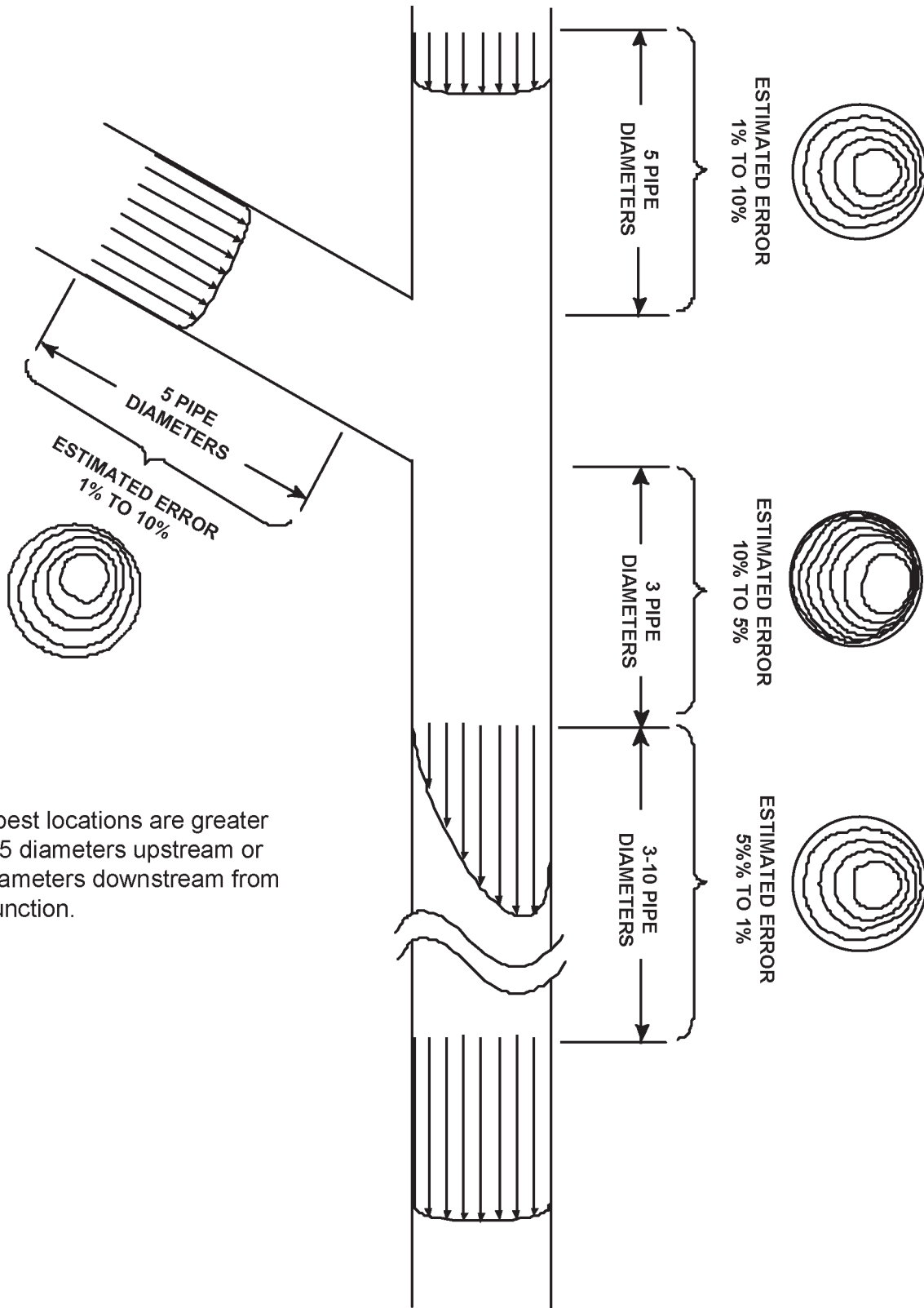

The best locations are greater than 5 diameters upstream or 10 diameters downstream from the junction.

## Y-Junction

*(errors are estimated for flow at 10 ft/sec)*

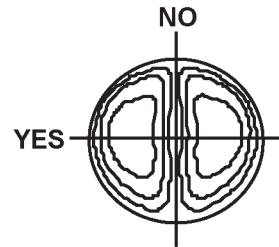
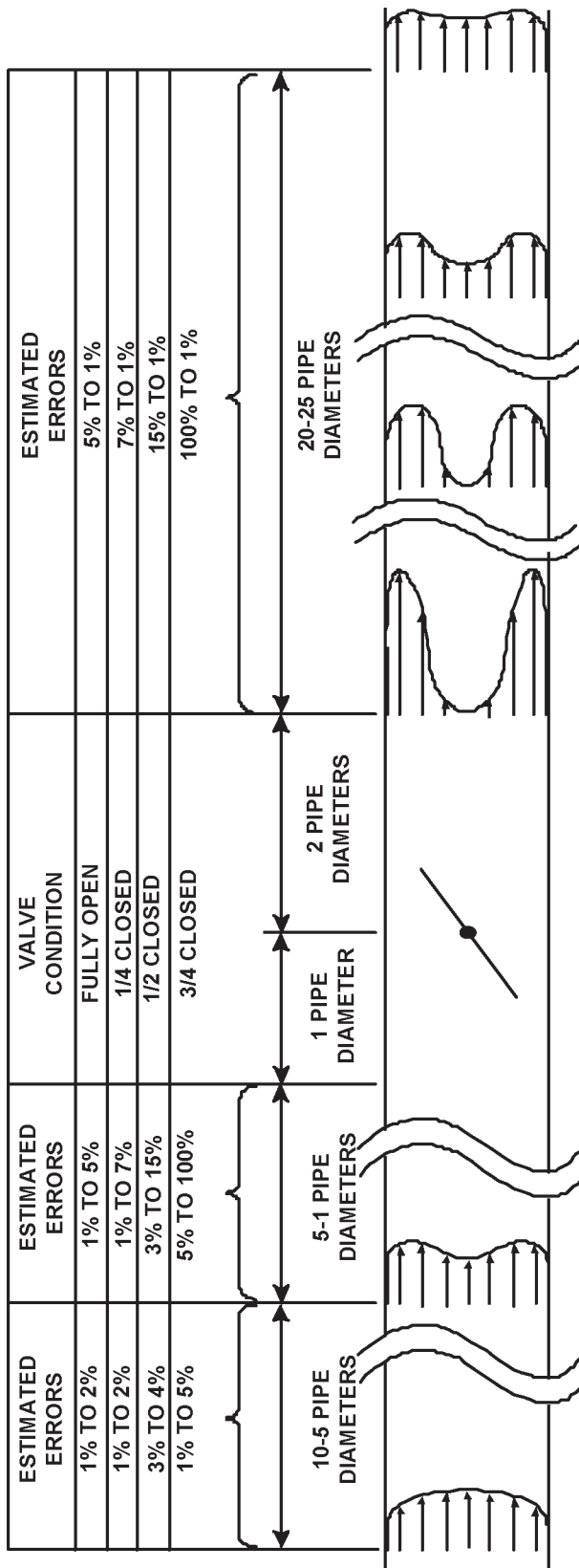

Recommended insertion angle for active valves.

The purpose of an active valve is to vary the flow. An active valve will produce a distorted profile that changes as the flow changes. As a result, the sensor should be installed at least 10 diameters upstream or 25 diameters downstream from an active valve to obtain 1% accuracy. The upstream side is the preferred location.

## Active Valves

(errors are estimated for flow at 10 ft/sec)

The best locations are greater than 10 diameters downstream or 1 diameter upstream from the junction.

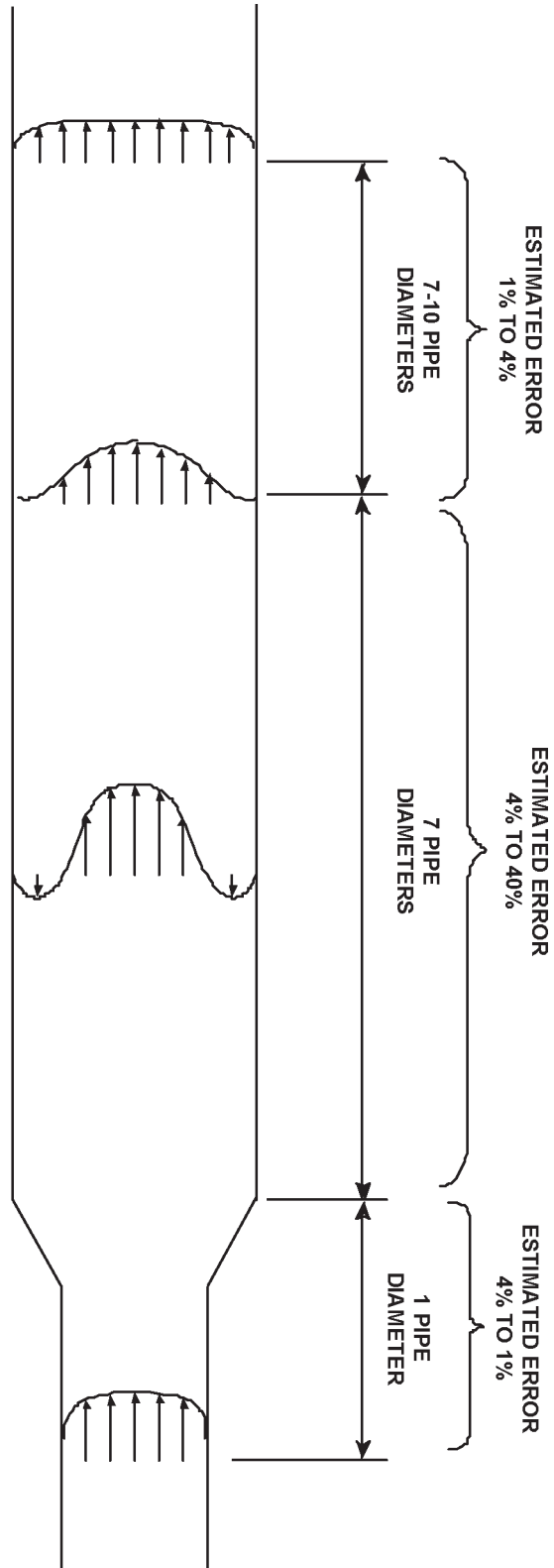
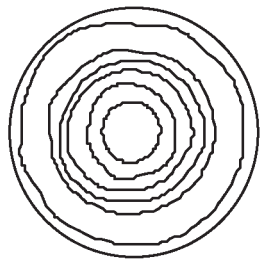

## Small-Large Pipe Junction

*(errors are estimated for flow at 10 ft/sec)*



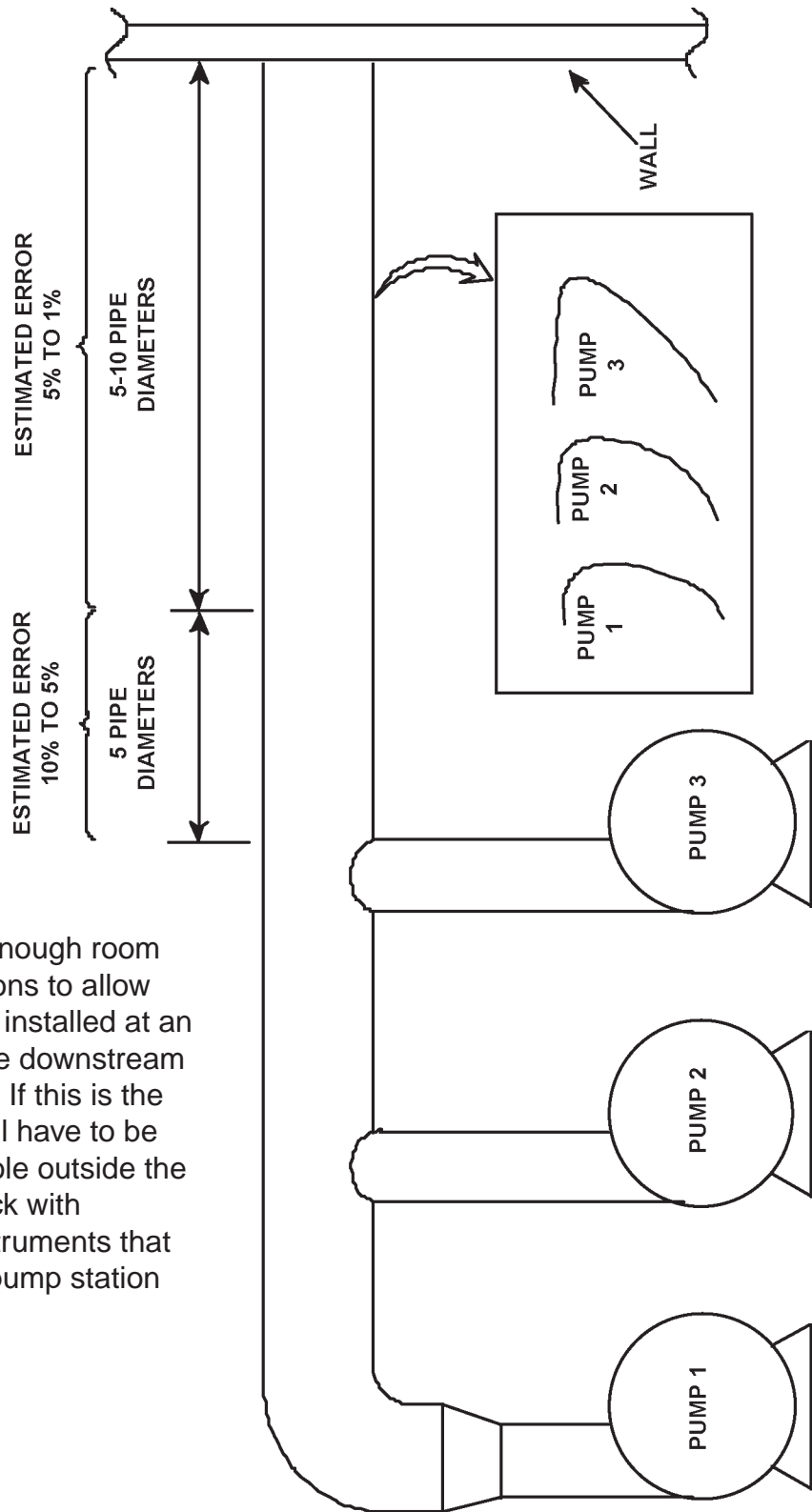

There may not be enough room in some pump stations to allow for the sensor to be installed at an appropriate distance downstream from the last pump. If this is the case, the sensor will have to be installed in a manhole outside the pump station. Check with McCrometer for instruments that are best suited for pump station applications.

## Pump Station

*(errors are estimated for flow at 10 ft/sec)*

01/02/96

# McCROMETER, INC. MULTI-MAG SENSOR SUBMITTAL SHEET

Company Name \_\_\_\_\_  
 Site Identification \_\_\_\_\_  
 Customer Contact \_\_\_\_\_  
 Date Received \_\_\_\_\_  
 Sales Order \_\_\_\_\_

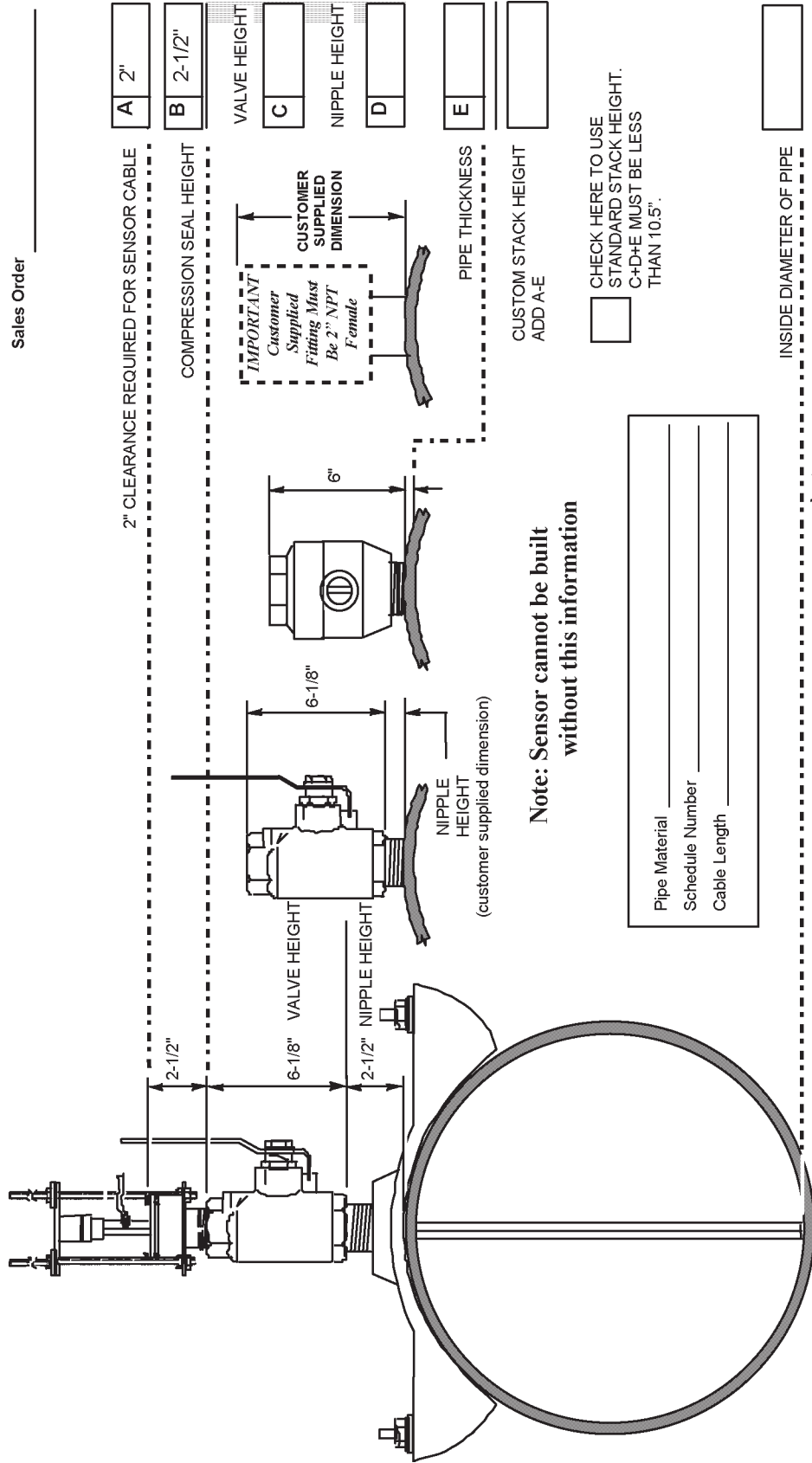

A	2"
B	2-1/2"
C	VALVE HEIGHT
D	NIPPLE HEIGHT
E	PIPE THICKNESS
	CUSTOM STACK HEIGHT ADD A-E

CHECK HERE TO USE  
STANDARD STACK HEIGHT.  
C+D+E MUST BE LESS  
THAN 10.5".

Pipe Material \_\_\_\_\_  
 Schedule Number \_\_\_\_\_  
 Cable Length \_\_\_\_\_

INSIDE DIAMETER OF PIPE \_\_\_\_\_  
 TOTAL SENSOR LENGTH  
 PIPE ID + STACK HEIGHT  
 STANDARD STACK HEIGHT = 15" \_\_\_\_\_

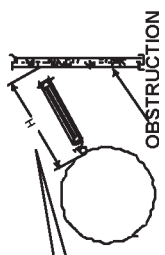

**IMPORTANT:** Distance H must be at least  
pipe ID + twice the stack height + 6"

# Specifications

## MEASUREMENT

Volumetric flow in filled flow conduits 6" (15.24 cm.) to 60" (152.4 cm) utilizing insertable electromagnetic averaging sensor. Flow indication in English Std. or Metric units.

## FLOW MEASUREMENT

Method: Electromagnetic  
Zero Stability:  $\pm 0.05$  ft/s  
Range:  $\pm 20$  ft/s (pipe sizes 24" and under)  
 $\pm 10$  ft/s (pipe sizes 24" to 42")  
 $\pm 5$  ft/s (pipe sizes 42" to 60")  
(consult factory for pipe sizes > 60")  
Accuracy:  $\pm 1\%$  of reading from 0 to  
 $+10$  ft/s + zero stability  
 $\pm 2\%$  of reading from 0 to  
 $-10$  ft/s + zero stability  
Linearity: 0.3% of range  
Repeatability: 0.20% of range

## POWER REQUIREMENTS

90-265VAC/44-66 Hz  
20W/25VA

## MATERIALS

Sensor: Fiberglass  
Cable: Polyurethane outer jacket  
Insertion Hardware: 316 stainless steel exposed to flow.  
Compression Seal: Silicone RTV  
Sensor Electrodes: Carbon  
6" to 11" sensor = 3 pairs  
12" to 60" sensor = 5 pairs

## OUTPUTS

Standard:  
Isolated 4-20mA current loop interface, maximum loop impedance 1000 ohms.  
  
Real-Time Display: Indicates flow and velocity.  
  
Totalizer Display: User selectable engineering units.  
  
Two Programmable Outputs

## ENVIRONMENTAL

Pressure/temperature limits:

Sensor: Flow temperature range 32° to 110°F (0° to 44°C) @ 250 psi

Electronics: Temperature limits -4° to 140°F (-20° to 60°C)

## DIMENSIONS

Modified NEMA 6 cast aluminum enclosure.  
Dimensions: 9.1"H x 5.7"W x 6.7"D  
23.0cm x 14.6cm x 17.0cm  
Weight: 6.8 lbs. (w/o sensor)

## SAFETY STANDARD

CE Certified

## ORDERING INFORMATION

Multi-Mag flowmeter includes modified NEMA 6 electronics enclosure, electromagnetic velocity sensor with 20' cable, LCD backlit display of flow in engineering units and totalization of flow, three-key keypad, site set-up of flowmeter via menu-driven software, two programmable open-collector outputs, one 4-20mA output of flow rate, password protection, and one instruction manual.

Options include additional 4-20 mA and two programmable outputs, extended sensor cable (maximum length 300'), and additional instruction manuals

# Model 284 Ordering Information

The standard Model 284 includes:

- NEMA 6 (IP67)
- Three-key numerical keypad
- One graphical backlit LCD display
- Two programmable open-collector outputs
- One 4-20 mA output
- Multi-Mag™ Sensor
- 20-foot sensor cable
- Installation and Operation Manual

## Options

- 4-20 mA output

## To order

The standard features and options required are designated by the ordering number (284-XX.X).

90-265 VAC, 44-66 Hz (standard)	0	_____			
10-35 VDC (optional)	1				
4-20mA flow output (standard)	0	_____			
4-20 mA flow, velocity output (optional)	1				
Sensor length range _____					

The ordering number 284-11 designates a meter with 10-35 VDC power and both flow and velocity 4-20mA outputs (for example).

### NOTE

A *Sensor Specification Sheet* (page 54) should be completed and submitted with all orders.

# Spare Parts List

	<u>Part Number</u>
Installation and Operation.....	105 0029 01
Sensor Insertion Tool .....	75031
Sensor Cable (specify length up to 300') .....	36001

## Returning a Unit for Repair

If the unit needs to be returned to the factory for repair, please do the following:

- Prior to calling for a return authorization number, determine the model number, serial number (located inside the front panel of converter), and reason for return.
- Call the McCrometer Customer Service Department and ask for a Return Authorization (RA) number.
- Ship the meter in the original packaging, if possible. Do not ship manuals, power cords, or other parts with your unit unless required for repair.
- Please make sure the meter is clean and free from foreign debris prior to shipping.
- Write the RA number on the outside of the shipping box. All return shipments should be insured.
- Address all shipments to:

McCrometer, Inc.  
RMA #  
3255 W. Stetson Ave  
Hemet, CA 92545

## Table of Decimal Equivalents

Fraction	Decimal
1/8	.125
1/4	.25
3/8	.375
1/2	.5
5/8	.625
3/4	.75
7/8	.875

## Table of Conversions

Multiply	By	To Get
Centimeters	0.3937	Inches
Centimeters	0.03281	Feet
Inches	2.54	Centimeters
Feet	30.48	Centimeters
Sq. Ft.	144.0	Sq. In
Sq. In	0.006944	Sq. Ft.
Cu. In	0.0005787	Cu. Ft.
Cu. Ft.	7.481	Gallons
Cu. Ft.	1728.0	Cu. In
Cu. Ft.	0.02832	Cu. Meters
Cu. Ft.	28.32	Liters
Cu. Meters	35.31	Cu. Ft.
Cu. Meters	264.2	Gallons
Gallons	3.785	Liters
Gallons	0.1337	Cu. Ft.
Gallons	0.003785	Cu. Meters
Liters	0.2642	Gallons
$^{\circ}\text{F} = (^{\circ}\text{C} \times 9/5) + 32$		$^{\circ}\text{C} = (^{\circ}\text{F} - 32) \times 5/9$

McCrometer, Inc. reserves the right to revise this publication and to make changes in its content without obligation to notify any person of such revision or changes.

Multi-Mag™ is a trademark of McCrometer, Inc.