

INSTRUCTIONS / INSTRUCTIONS / INSTRUCCIONES

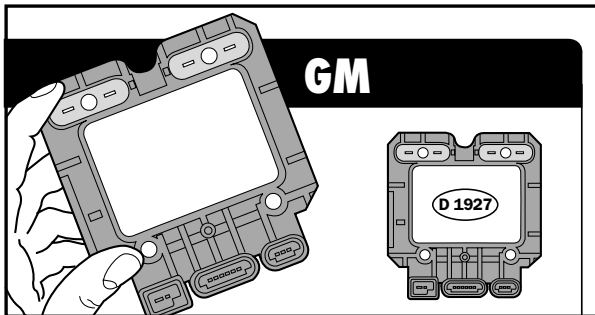

- 1) Match Ignition Module to Map.
 1) Jumeler le module et la carte.
 1) Seleccione el diagrama apropiado para el módulo.

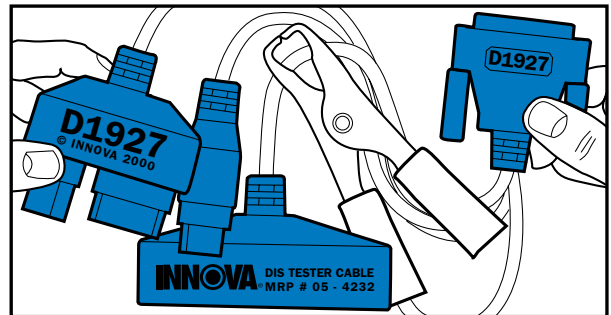

- 2) Locate Matching Cable.
 2) Trouver le câble et le raccorder au module.
 2) Encuentre el cable y conéctelo al módulo.

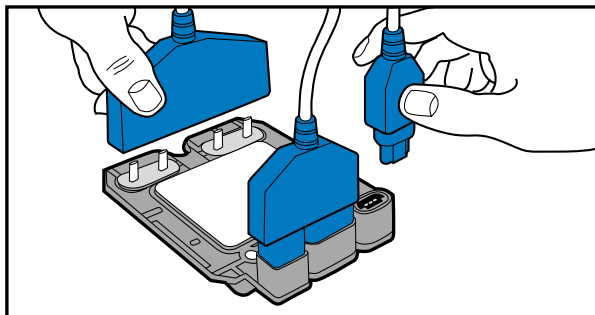

- 3) Connect All Cable Ends (Connectors only fit one way – DO NOT FORCE!)
 3) Branchez toutes les extrémités de câble (les connecteurs ne peuvent être insérés que d'une seule manière – NE PAS EXERCER UNE FORCE EXCESSIVE!)
 3) Conectar todos los extremos de los cables (los conectores enchufan en un solo sentido – ¡NO FORZARLOS!)

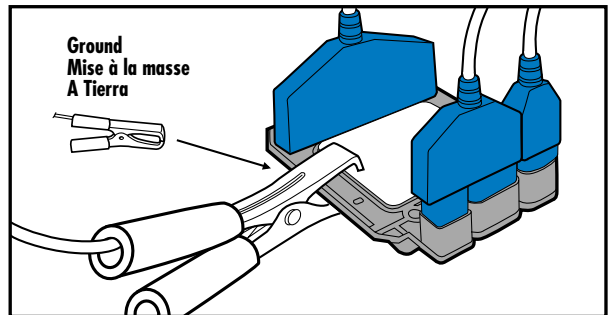

- 4) Ground Ignition Module (Clamp must touch module's metallic surface.)
 4) Mettez le module d'allumage à la masse (la pince doit toucher la surface métallique du module.)
 4) Conectar a tierra el módulo del encendido (El caimán debe tocar la superficie metálica del módulo.)



CAUTION: MODULE MAY BE EXTREMELY HOT - USE CAUTION!
 DO NOT TEST MORE THAN 3 CONSECUTIVE TIMES.

MISE EN GARDE: LE MODULE PEUT ÊTRE EXTRÊMEMENT CHAUD - ATTENTION!
 IL NE FAUT PAS FAIRE PLUS DE 3 VÉRIFICATIONS DE SUITE.

PRECAUCIÓN: EL MÓDULO PUEDE ESTAR MUY CALIENTE. ¡SEA CUIDADOSO!
 NO HAGA MÁS DE 3 PRUEBAS CONSECUTIVAS.



TECHNICAL SERVICE
 SERVICE TECHIQUE
 SERVICIO TÉCNICO

1-800-544-4124 • 714-241-6803
 Monday to Friday 7 AM - 4 PM PST

CUSTOMER SERVICE
 SERVICE À LA CLIENTÈLE
 SERVICIO AL CLIENTE

714-241-6803

FAX • TÉLÉCOPIER • FAX
 714-432-7511

www.DIStester.com

U.S. Patent #5,635,841 Printed in USA • Imprimé aux États-Unis • Impreso en EE.UU.

GENERAL MOTORS

MRP #93-0138

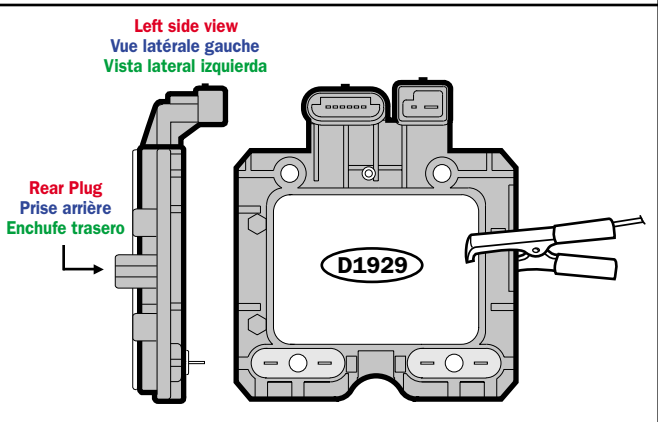
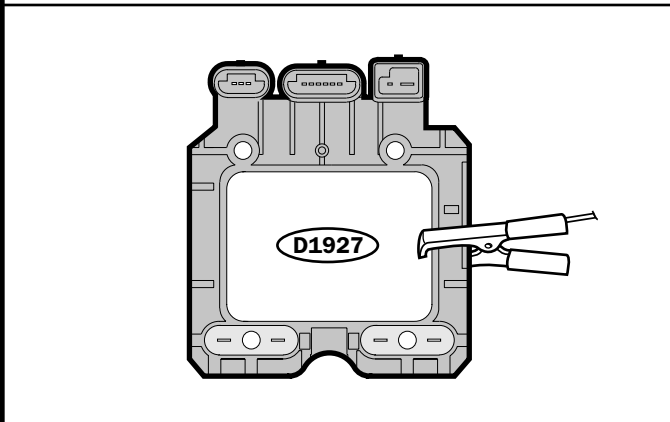
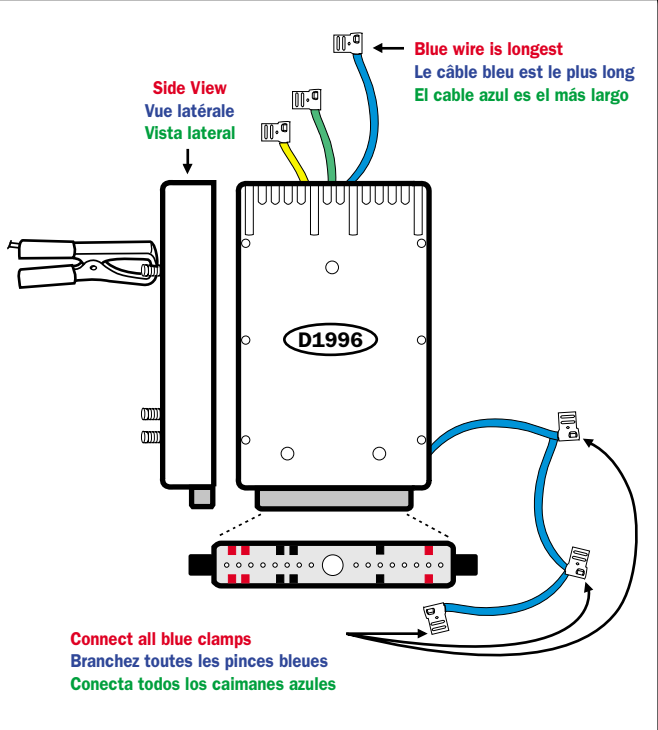
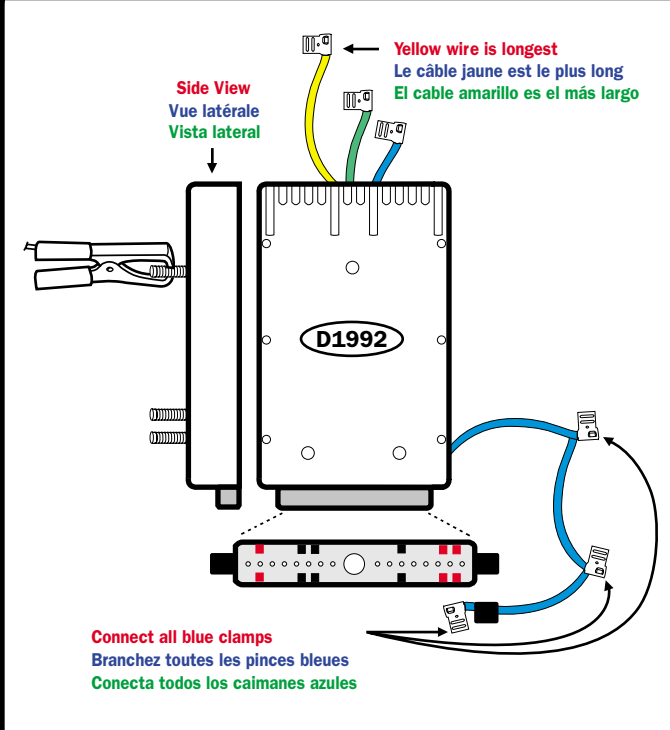

WARNING: Verify model year and engine size before testing!
AVERTISSEMENT: Vérifiez l'année du modèle et la cylindrée du moteur avant de commencer l'essai !
ADVERTENCIA: ¡Verifica el año, modelo y desplazamiento del motor antes de efectuar las pruebas!

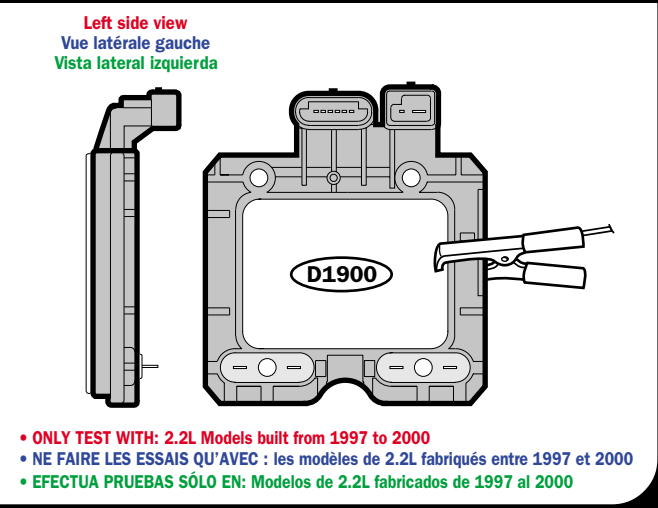
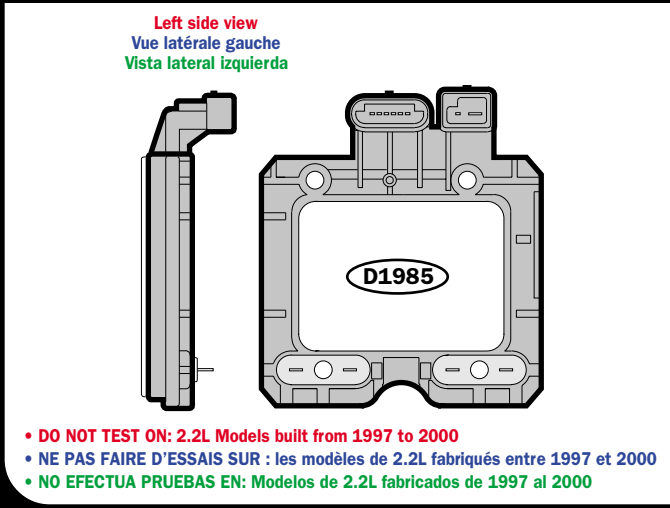

© IEC 2001

DIS MODULE MAP • CARTE DU MODULE « DIS » • DIAGRAMA DEL MÓDULO DIS

GENERAL MOTORS

- Match with cable grooves
- Jumelez par rapport aux encoches pratiquées dans le câble
- Hacer concordar con las ranuras del cable

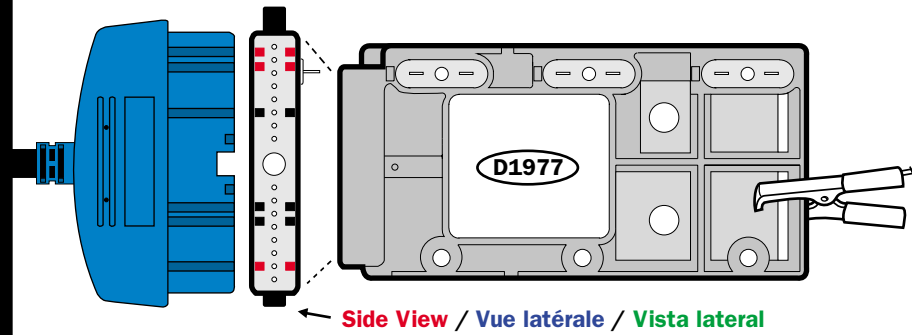

- Uses 8 pins
- Utilisez 8 broches
- Usa 8 clavijas

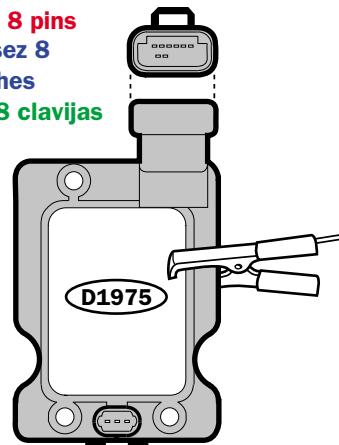

- Match with cable grooves
- Jumelez par rapport aux encoches pratiquées dans le câble
- Hacer concordar con las ranuras del cable

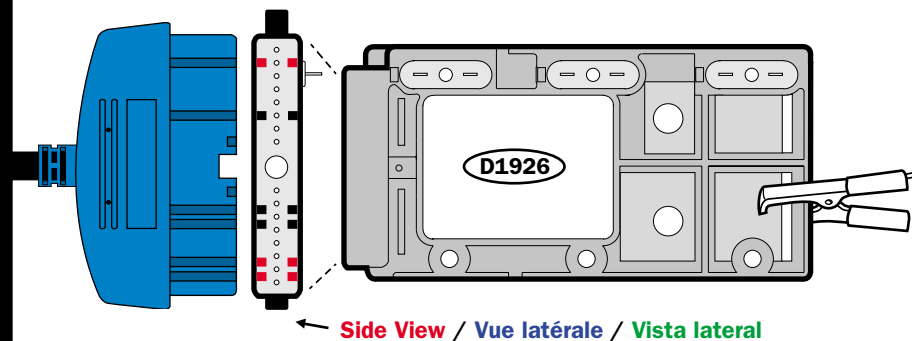

- Uses 11 pins
- Utilisez 11 broches
- Usa 11 clavijas

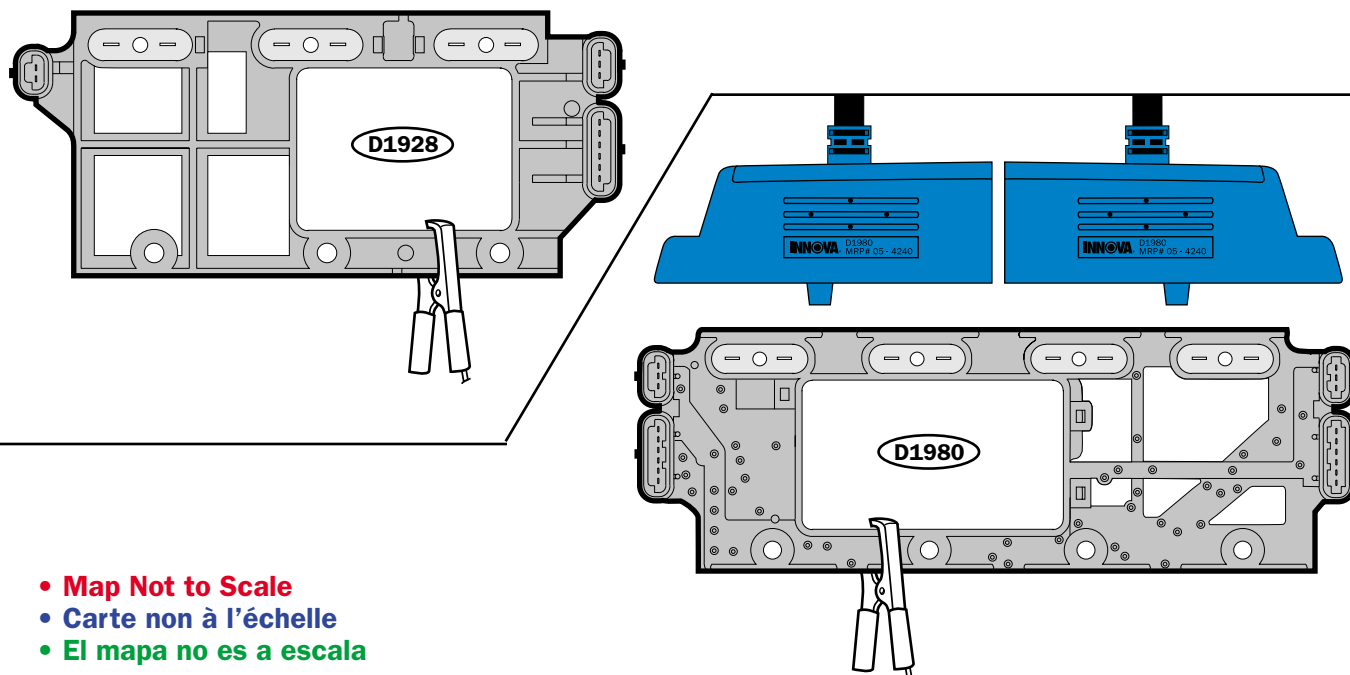
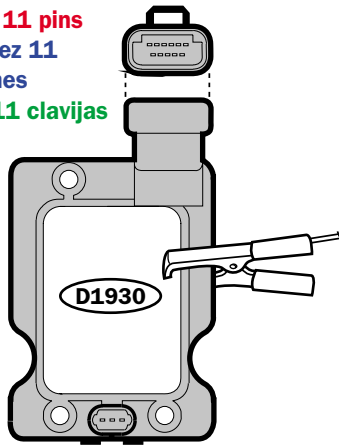

- Map Not to Scale
- Carte non à l'échelle
- El mapa no es a escala

FORD

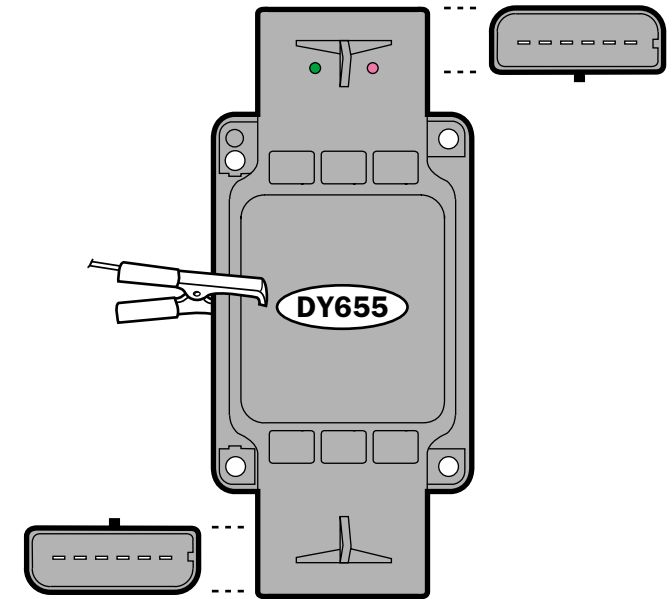

WARNING: Verify the number of cylinders before testing!
AVERTISSEMENT: Vérifiez la cylindrée du moteur avant de commencer l'essai!
ADVERTENCIA: Verifica el numero de cilindros antes de efectuar la prueba!

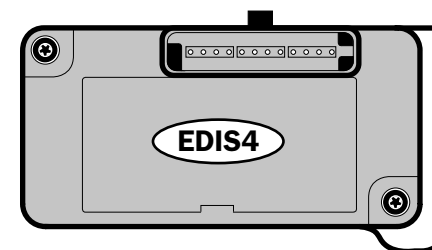

- 4-Cylinder Models Only
- Modèles à 4 cylindres uniquement
- Sólo modelos de 4 cilindros

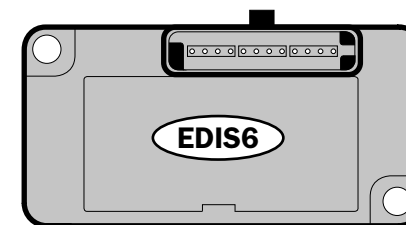

- 6-Cylinder Models Only
- Modèles à 6 cylindres uniquement
- Sólo modelos de 6 cilindros

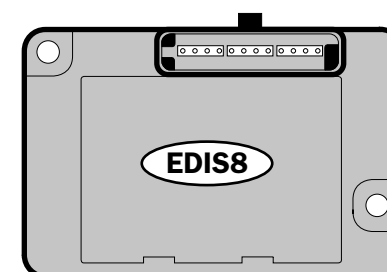

- 8-Cylinder Models Only
- Modèles à 8 cylindres uniquement
- Sólo modelos de 8 cilindros

FORD

GENERAL MOTORS

MRP #93-0138

CABLE # EDIS4

| Manufacturer | Part Number / Numéro de pièce / Número de Parte |
|---------------------|---|
| AC Delco | 19017159; F1945 |
| Auto Tune | PT6909 |
| BWD | CBE114 |
| Filko | F0319 |
| GP Sorensen | EL162 |
| Motorcraft | DY630; F0CF12A359AB; F0CF12A359AC; F1CZ12A297A; F1CZ12A297B; F1CZ12K072A; F1CZ12K072B |
| NAPA-Echlin | TP500; TP515 |
| Niehoff | FF424A |
| Standard | LX239 |
| Wells Manufacturing | F140; F157 |

CABLE # EDIS6

| Manufacturer | Part Number / Numéro de pièce / Número de Parte |
|---------------------|--|
| AC Delco | 19017168 |
| Auto Tune | PT6910; PT6912; PT7088; PT7095 |
| BWD | CBE115; CBE116; CBE52; CBE59 |
| Filko | F0329; F0332 |
| GP Sorensen | EL375; EL378 |
| Motorcraft | 90GB12K072AB; DY629; DY657; DY680; DY682; DY689; DY724; DY727; F07F12K072BA; F0TZ12K072B; F0TZ12K072BA; F1TZ12K072B; F1TZ12K072BA; F4SZ12K072B; F4ZF12K072AC; F4ZF12K072BB; F4ZF12K072BC; F4ZZ12K072A; F4ZZ12K072B |
| NAPA-Echlin | TP504; TP507; TP513 |
| Niehoff | FF420; FF424C; FF424F; FF425E |
| OEM Mazda | ZZL018V80; ZZL018V80A |
| Standard | LX254; LX256 |
| Wells Manufacturing | F142; F158; F159; F169 |

CABLE # EDIS8

| Manufacturer | Part Number / Numéro de pièce / Número de Parte |
|---------------------|--|
| AC Delco | 19017160; F1946 |
| Auto Tune | PT7089; PT7092; PT7093 |
| BWD | CBE53; CBE56; CBE57 |
| Filko | F0323 |
| GP Sorensen | EL174 |
| Motorcraft | DY644; DY687; DY726; DY755A; DY887; F1AF12K072AC; F1AF12K072AD; F1AZ12K072A; F3LF12K072AA; F3LY12K072A; F4SZ12K072A; F5SF12K072AA; F5SZ12126AA; F5SZ12K072AA |
| NAPA-Echlin | TP508 |
| Niehoff | FF421; FF425A; FF426A |
| Standard | LX243 |
| Wells Manufacturing | F143; F144 |

CABLE # DY655

| Manufacturer | Part Number / Numéro de pièce / Número de Parte |
|---------------------|---|
| AC Delco | 19017161; F1947 |
| Auto Tune | PT7028; PT7029 |
| BWD | CBE41; CBE42; CBE58 |
| Filko | F0315; F0316; F0322 |
| GP Sorensen | EL144; EL146; EL172 |
| Motorcraft | 81SF12297FB; DY537; DY554; DY655; E8TF12A297AA; E8TZ12A297A; E9DF12A297BA; E9DZ12A297B; F1SF12A297BA; F1SZ12A297B |
| NAPA-Echlin | TP502; TP503; TP56 |
| Niehoff | FF414; FF415; FF424 |
| Standard | LX230; LX231; LX242 |
| Wells Manufacturing | F136; F138; F147 |

CABLE # D1900

| Manufacturer | Part Number / Numéro de pièce / Número de Parte |
|---------------------|---|
| AC Delco | 110490872; D-1900C; 8-10490-872-0 |
| BWD | CBE120 |
| Filko | DR492 |
| GP Sorensen | EL390 |
| NAPA-Echlin | TP423 |
| Niehoff | DR421E |
| Standard | LX382 |
| Wells Manufacturing | DR186 |

CABLE # D1926

| Manufacturer | Part Number / Numéro de pièce / Número de Parte |
|---------------------|--|
| AC Delco | 10456478; 10467439; 1103608; 1989533; D-1923A; D-1926A; D-1946A; D-19945 |
| Auto Tune | E448 |
| BWD | CBE103 |
| Filko | DR315 |
| GP Sorensen | EL141 |
| NAPA-Echlin | TP403 |
| Niehoff | DR424G |
| Regitar | D1926A |
| Standard | LX348 |
| Wells Manufacturing | DR150 |

CABLE # D1927

| Manufacturer | Part Number / Numéro de pièce / Número de Parte |
|---------------------|---|
| AC Delco | 10467214; 10472184; 10476631; 10487425; 10499427; 10499794; D-1911A; D-1927A; D-1969A |
| Auto Tune | E7004; PT7004; PT7031 |
| BWD | CBE106; CBE111 |
| Filko | DR318; DR322 |
| GP Sorensen | EL137; EL152 |
| NAPA-Echlin | TP406; TP409 |
| Niehoff | DR424R; DR424Z |
| Regitar | D1927A |
| Standard | LX345; LX356 |
| Wells Manufacturing | DR149; DR155 |

CABLE # D1928

| Manufacturer | Part Number / Numéro de pièce / Número de Parte |
|--------------|---|
| AC Delco | 10467202; 10476627; 10489422; 10496146; 10499430; 10499803; D-1910A; D-1928A; D-1998A |
| Auto Tune | E368; PT368 |
| BWD | CBE104 |
| Filko | DR316 |
| GP Sorensen | EL138 |
| Mobiletron | IG-D1928 |
| NAPA-Echlin | TP404 |
| Niehoff | DR424K |
| OEM Isuzu | 8104672020 |
| Regitar | D1928A |

| | |
|---------------------|-------|
| Standard | LX346 |
| Wells Manufacturing | DR145 |

CABLE # D1929

| Manufacturer | Part Number / Numéro de pièce / Número de Parte |
|---------------------|--|
| AC Delco | 10467208; 10496123; 10499424; 10499797; 1103745; D-1929A; D1909A |
| Auto Tune | E367; PT367 |
| BWD | CBE105 |
| Filko | DR317 |
| GP Sorensen | EL136 |
| NAPA-Echlin | TP405 |
| Niehoff | DR424M |
| Regitar | D1929A |
| Standard | LX344 |
| Wells Manufacturing | DR144 |

CABLE # D1930

| Manufacturer | Part Number / Numéro de pièce / Número de Parte |
|---------------------|---|
| AC Delco | 10467220; 10469827; 10469867; 10497502; D-1912A; D-1930A; D-1935A |
| Auto Tune | E366; PT366; PT7097 |
| BWD | CBE101; CBE102 |
| Filko | DR314 |
| GP Sorensen | EL140 |
| NAPA-Echlin | TP401 |
| Niehoff | DR424A; DR424E |
| Standard | LX347 |
| Wells Manufacturing | DR141 |

CABLE # D1975

| Manufacturer | Part Number / Numéro de pièce / Número de Parte |
|---------------------|---|
| AC Delco | 10474118; 10487716; D-1975A; D-1991A; D-911A |
| Auto Tune | PT7071 |
| BWD | CBE45 |
| Filko | DR328 |
| GP Sorensen | EL376 |
| NAPA-Echlin | TP412 |
| Niehoff | DR420C |
| Standard | LX366 |
| Wells Manufacturing | DR156 |

CABLE # D1977

| Manufacturer | Part Number / Numéro de pièce / Número de Parte |
|---------------------|---|
| AC Delco | 10469470; 10475225; 10494012; D-1940A; D-1977A |
| Auto Tune | PT7024; PT7073 |
| BWD | CBE109; CBE47 |
| Filko | DR326 |
| GP Sorensen | EL183 |
| NAPA-Echlin | TP413; TP414 |
| Niehoff | DR420G; DR424U |
| Standard | LX364 |
| Wells Manufacturing | DR158 |

CABLE # D1980

| Manufacturer | Part Number / Numéro de pièce / Número de Parte |
|---------------------|---|
| AC Delco | 10472121; 10477066; 10477276; D-1980A; D-6133 |
| Auto Tune | PT7030 |
| BWD | CBE110; CBE43 |
| Filko | DR324 |
| GP Sorensen | EL189 |
| NAPA-Echlin | TP415 |
| Niehoff | DR420; DR424X |
| Standard | LX362 |
| Wells Manufacturing | DR160 |

CABLE # D1985

| Manufacturer | Part Number / Numéro de pièce / Número de Parte |
|---------------------|---|
| AC Delco | 10474855; 10476634; D-1628; D-1985A; D-6128 |
| Auto Tune | PT7072 |
| BWD | CBE46 |
| Filko | DR329 |
| GP Sorensen | EL192 |
| NAPA-Echlin | TP410 |
| Niehoff | DR420E |
| OEM Isuzu | 8104748550 |
| Standard | LX367 |
| Wells Manufacturing | DR173 |

CABLE # D1992

| Manufacturer | Part Number / Numéro de pièce / Número de Parte |
|---------------------|---|
| AC Delco | 24503623; 25526121; 25533540; D-1922A |
| Auto Tune | PT7012 |
| BWD | CBE107 |
| Filko | DR319 |
| GP Sorensen | EL142 |
| NAPA-Echlin | TP407 |
| Niehoff | DR424S |
| Regitar | D1922A |
| Standard | LX349 |
| Wells Manufacturing | DR148 |

CABLE # D1996

| Manufacturer | Part Number / Numéro de pièce / Número de Parte |
|---------------------|---|
| AC Delco | 24503624; 25526449; D-1996 |
| Auto Tune | E7003; PT7003 |
| BWD | CBE100 |
| Filko | DR310 |
| GP Sorensen | EL133 |
| NAPA-Echlin | TP400 |
| Niehoff | DR424 |
| Regitar | D1996A |
| Standard | LX338 |
| Wells Manufacturing | DR143; DR152 |

NOTE: This chart should not be used to cross-reference between ignition module manufacturers. Refer to each manufacturer's cross-reference guide.
REMARQUE: Ce tableau ne doit pas être utilisé comme référence entre les différents fabricants de modules d'allumage. Consultez le guide de référence de chaque fabricant.
NOTA: Esta tabla no debe usarse como referencia cruzada entre fabricantes de módulos de encendido. Consulte la guía de referencias cruzadas de cada fabricante.

© IEC 2001