

# X803 ELECTRONIC CARD

## Control unit for generating sets

### OPERATING MANUAL

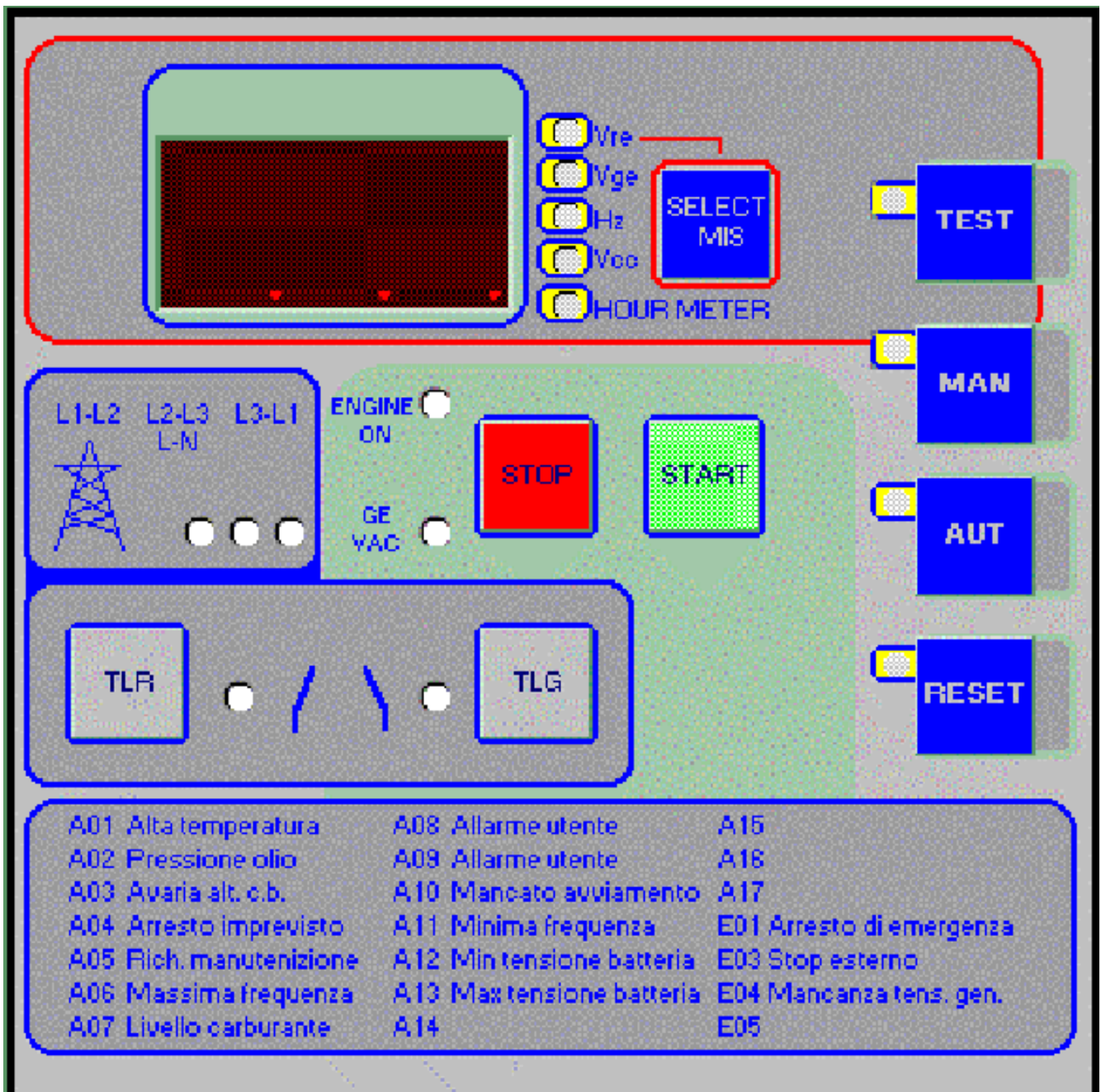

The technical data and description in the operation manual is subject to alterations and changes at any time and have no contractual value. The X803 device should be used by skilled and qualified personnel and in compliance with the regulations in force for electrical systems in order to avoid damages to persons and property.

<b>CONTENTS</b>	<b>Page</b>
<b>DESCRIPTION</b>	3
Front plate	3
<b>OPERATING MODE DESCRIPTION</b>	4
RESET Mode	4
AUTOMATIC Mode	4
MANUAL Mode	4
TEST Mode	4
<b>OPERATING DESCRIPTION</b>	5
Start-up cycle of generating set	5
Stop cycle of generating set	5
Engine started signal	5
Mains voltage present	6
Generator voltage present	6
Mains/Gen and Gen/Mains changeover	6
Alarm tripping	7
Siren relay	7
Global alarm relay	7
Readings display	7
Generating set's operation hour-meter	8
Maintenance	8
<b>FUNCTIONS</b>	9
Automatic test	9
Enabling and disabling automatic test	9
Emergency stop	9
Remote starting	9
Remote stop	10
EJP function	10
EJP/T function	10
SCR function	10
Closed coupled pump operation	10
Decelerator function	11
Gas solenoid valve function	11
Starter function	11
Air function	11
<b>REMOTE CONTROL</b>	11
<b>INFORMATION - ALARMS- ERRORS</b>	12
Information	12
Alarms	12
Alarms table	14
Errors	14
<b>INPUTS AND OUTPUTS</b>	14
Inputs table	14
Outputs table	14
<b>PROGRAMMING</b>	15
<b>PARAMETERS</b>	15
Option menu	15
Set up menu	16
<b>TECHNICAL CHARACTERISTICS</b>	17
<b>REFERENCE STANDARDS</b>	19
<b>TERMINAL BLOCK CONNECTIONS</b>	20
<b>DIAGRAMS</b>	21

### DESCRIPTION

The digital control unit X803 is a device able to conduct RMS voltage reading and accurate timely controls of all the necessary functions, to obtain the optimum operation of the generating set. The extensive programming of input and output functions as well as the numerous operating parameters contribute to the X803 unit a flexibility so that it is easily adaptable to different application requirements.

The version with RS485 serial interface provides the generating set to be remotely supervised without any limitation.

#### Front Plate

- 3-digit display for reading, alarm, message or error indication
- RESET-MAN-AUT-TEST keys for operating mode selection
- SELECT-MIS key for display selection
- START-STOP keys for engine starting and stopping in manual mode
- MAINS (TLR)-GEN(TLG) keys for mains and generator contact change-over in manual mode
- RESET- AUT - MAN -TEST LED's for indication of selected operating mode
- MAINS(VRE)-GEN(VGE)-Hz-BATT(Vcc)-HOUR LED's for indication of selected reading
- ENGINE ON LED to indicate engine running
- Mains (L1-L2, L2-L3/L-N, L3-L1) and generator voltage indication LED's
- Generator and mains contact status LED's

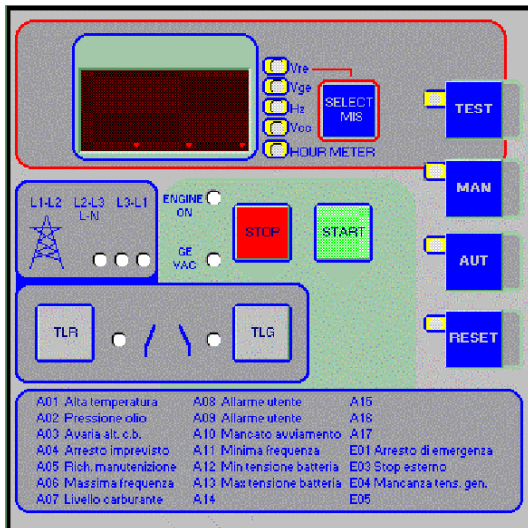

### OPERATING MODE DESCRIPTION

**Note** In this manual, all underlined texts refer to those parameters that can be programmed through access to the two menus named OPTION and SETUP. See the corresponding section for further information.

- The X803 unit can operated in four different operating modes: RESET, AUT, MAN and TEST
- By pressing one of the operating mode keys, the relative LED switches on indicating the exact operating mode selected. The change from one operating mode to another is possible at any time.
- The operating mode remains stored even if the supply is removed.
- The flashing operating mode LED indicates that the unit is controlled by a supervising system. Since the controls can be remotely conducted, it is essential to operate with care.

#### RESET Mode

- When the unit is in RESET mode, all outputs are de-energized, in other words in the same condition as when the set is unpowered, except for the global alarm output that continues to operate as normal.
- In this mode the mains remote control relay stays on standby, with the contact closed.
- In addition, the control inputs and siren output are disabled.
- Whereas the warning LED's, reading display and alarms are active.
- When passing from MAN/AUT/TEST mode to RESET mode and the generating set is running, the unit proceeds to stop it automatically without waiting for the cooling time (option P.09).

#### AUTOMATIC Mode

- In AUT mode, when there is no mains voltage after the delay for mains voltage absence (option P.03), the mains contact output is de-energized and the starting cycle of the generating set is begun.
- When the generating set is running and the generator voltage is available, after generator voltage presence delay (delay for generator contact closing (option P.08)) has lapsed, the generator contact output is energized.
- At the return of mains voltage and after the delay for mains voltage presence (option P.04), the generator contact output is de-energized, the mains contact output is energized and then, the stop cycle of the generating set is activated.
- The external controls of the emergency stop and remote starting are enabled.

#### MANUAL Mode

- In MAN, the generating set can be started or stopped by pressing START or STOP keys. An unrequired STOP control can be invalidated at once by pushing the START key.
- It is possible, to change the contactor MAINS(TLR) or GENERATOR(TLG) or vice versa, for to make this it's necessary pressing the MAN button together button (TLR)MAINS or (TLG)GENERATOR
- The control of the generator contact output is inhibited if the generating set is not running.
- A mains/generator interlock time (set up -15) is always imposed at each load changeover control, between the de-energizing of one output and the energizing of another.
- The passage from AUT or TEST to MAN mode leaves the operating state of the generating set unchanged.

#### TEST Mode

- The start cycle of the generating set takes place whenever TEST mode is selected.
- The load is automatically switched over to the generator only with the lack of mains voltage. At its return, the load remains on the generator.
- Reinstating AUT mode, in presence of mains voltage, the changeover to the mains can take place and the generating set is stopped.

## OPERATING DESCRIPTION

### **Start-up cycle of the generating set**

The generating set start-up cycle includes the following operations in MAN, AUT, TEST modes or by remote starting facility:

- If preset, glow plug preheat output is energized.
- The fuel solenoid valve output is energized two seconds before the lapsing of glow-plug preheat time (set up -19),
- After these two seconds, the glow plug preheat output is de-energized and the start output is simultaneously energized for a time equal to the starting attempt duration (set up -11).
- If the glow plug preheat output is not programmed, the fuel solenoid valve output energizes always for two seconds before the start output is.
- During the starting attempt if the engine starts, the start output is instantly de-energized.
- If the engine running signal is not detected within the starting attempt duration (set up -11), the interval between starting attempts (set up -12) begins.
- In case of false start-up, another equal number of starting attempts (set up -10) is repeated as per the preset value.
- After the engine starts if the engine-started signal is no longer detected, the start output is re-energized once again after the delay between false start and the subsequent start (set up -13) (if preset). This starting is not included in the starting attempts count.
- The actual interval between starting attempts is equal to the total time of the starting attempt interval (set up -12) and, if preset, also the time for glow plug preheat duration (set up -19). During this interval, the fuel solenoid valve output is de-energized and, if preset, the stop magnet output is energized to assure engine stopping before the subsequent starting attempt.
- "StA" (Start) is indicated on the display during the start-up cycle and until the engine is running.
- If the engine has not started after the preset number of starting attempts (set up -10), the audible alarm is energized and "A10" (STARTING FAILURE) alarm is displayed.
- The alarm is reset by means of /RESET key.

### **Stop cycle of the generating set**

The stop cycle of the generating set comprises the following operations in MAN or AUT modes:

- "StO" (Stop) appears on the display.
- The generator contact output is de-energized, the cooling time (option P.09) of the engine starts.
- At the end of the cooling time (option P.09), the fuel valve output is de-energized and the stop magnet output is energized, if preset.
- Once the engine-started signal is no longer detected and after the subsequent energizing time of stop magnet (option P.09) has lapsed, the stop magnet output is de-energized.
- In case of alarm that provides for the stopping of the generating set or when in RESET mode, the cooling time (option P.09) is not conducted.

### **Engine started signal**

- The voltage threshold for the started motor detection can be applied either to the voltage supplied by the battery-charger alternator or to the voltage supplied by the generating set. This choice can be made through the following parameter: started motor signal choice (set-up -05).
- If set-up -05 is programmed onto 0, then the system will detect the started motor signal from the inlet of the battery-charger alternator (permanent magnets or pre-excited type), thus applying the threshold specified by the following parameter: alternator voltage started motor threshold (set-up -06).
- On the contrary, if set-up -05 is programmed onto 1, then the system will detect the started motor signal directly from the

generating set voltage, thus applying the threshold specified by the following parameter: generating set voltage started motor threshold (set-up -07).

- In every case, for safety reasons, the started motor signal is also detected by overcoming the generating set minimum voltage intervention threshold (option p.05). If there is generating set voltage, the motor is considered as started.
- The started motor signal is visualized by led "ENGINE ON".

### **Mains voltage present**

- If the three-phase/single-phase mains voltage control (set up -37) is programmed as three-phase, it is conducted on the three voltages between lines. An asymmetry control is carried out in addition to the voltage one.
- The mains voltage is considered present when the voltages between lines L1-L2, L2-L3 and L3-L1 are within the minimum mains voltage trip threshold (option P.01), maximum mains voltage trip threshold (option P.02) and maximum mains asymmetry (set up -42) limits. The presence of voltage is indicated by the L1-L2, L2-L3 and L3-L1 LED's when switched on.
- In AUT mode, mains contact output is energized after mains voltage presence delay (option P.04).
- The mains voltage is considered absent when one or more voltages between line, L1-L2, L2-L3 and L3-L1, are not within limits indicated above. The absence of voltage is shown when the L1-L2, L2-L3 and L3-L1 are switched off if the relative voltage between lines is not within the preset minimum and maximum threshold limits. Otherwise the LED's are flashing if the voltage is within the limits but asymmetry is higher than the pre-set value.
- In AUT mode, mains contact output is de-energized after the lapsing of the mains voltage absence delay (option P.03).
- In the case of single-phase mains voltage, the set must be programmed as a single-phase control. IN this case the control will only be made on the voltage at terminals 22-21, in the same manner as the three-phase control. In this case the LED involved in the control is L2-L3/L-N, whereas the others will be off.

### **Generator voltage presence**

- Generator voltage control is only single phase.
- Generator voltage is considered present when its value falls within minimum generator voltage trip threshold (option P.05), maximum generator voltage trip threshold (option P.06). The presence of voltage is indicated when the relative LED GE VAC is switched on.
- The alarm for the lack of generator voltage can be tripped at the absence of the generator voltage failure delay (option P.07) after the engine-started signal. This delay time can eventually include slow-running time (set up -18), if preset.
- In AUT mode, generator contact output is energized after the generator voltage presence delay (option P.08), which thereby takes on the function of a delay for putting a load on the motor (contact closing delay).
- The generator voltage is considered absent when it is not within the limits mentioned previously. The voltage absence is indicated when the LED is switched off.
- In AUT mode, after the absence of generator voltage failure delay (option P.07), the mains contact output is de-energized.
- If the motor is detected as running by the battery-charger alternator signal, but the generator voltage is not present for longer than the no generator voltage alarm time (set up -38) alarm E04 is generated. This alarm can be disabled with the no generator voltage alarm disabling parameter (set up -35).

### **Mains/Generator and Generator/Mains changeover**

- A mains/generator interlock time (set up -15) is imposed between the mains contact output de-energizing and the generator contact energizing and vice versa.
- In MAN mode, the load can be changed over to the mains or to the generator by pressing MAINS(TLR) or GEN(TLG) key. Press them together with the MAN button in order to avoid accidental movements. By pressing one of these repeatedly, the relative contact is closed or opened.
- The mains contact output is permanently energized when the control unit is not supplied.

### **Alarm tripping**

- The display normally shows one of the readings indicated by the MAINS(Vre), GEN(Vge), Hz, BATT(Vcc) or HOURS LED's.
- In case of alarm, the display indicates the alarm code, the meaning of which is given in the table on the X803 front plate.
- Depending on the alarm importance, this can trip the generating set operation or energize the audible alarm output.
- In case more than one alarm is present at the same time, they are visualized on the display one after another.
- Almost all the alarms are retentive and remain in this status even if the conditions that have generated the alarm no longer persist. Under these circumstances, the user is obliged to identify the faults and remove the alarm state. For further details see the alarm table.
- The alarms are reset by pushing RESET, which has effect on both the alarms and on the operating mode of X803. If the alarm situations persist, resetting the unit is not possible.
- In case the alarm situation cannot be resolved immediately, it is possible to have access to the readings by pressing the SELECT-MIS key for 2 seconds. After 20 seconds since last being pressed, the display reinstates the situation of the previous alarm condition.
- More details on the alarms and their properties are given in "Alarms Table".

### **Siren relay**

- The siren relay is activated when there is an alarm. It stays activated for a programmable time through the siren alarm time parameter (option P.10). Afterwards, it is inactivated.
- Furthermore, this relay is activated before starting up the motor (due to an automatic test or to an external start or to an EJP start). In this case the sound has a fixed length corresponding to 5 seconds and is followed by a 3-second pause before the real start-up. This will help maintenance operators realize that the group is going to be started up even if the mains are plugged in.
- If you want the siren relay not to be activated for reasons other than an alarm, it is possible to specifically program the following parameter: siren signal activation before start-up (set-up -02).
- If the unit is in the reset mode, the siren will never be activated even if an alarm is going on.

### **Global alarm relay**

- The global alarm relay is activated when there is an alarm situation and it stays activated until all alarm situations are terminated and until the operator has switched them off by pushing the reset button.
- The only alarms that do not require the closing of the global alarm relay are the external EO3 stop and, possible, the programmable alarms, provided that they have been programmed in order to be visible alarms only.
- For the global alarm relay we have provided a separate common switch and an exchange contact.

- This relay can be used for the gas solenoid valve function (please see set-up -29). In that case, the global alarm signal is not available.

### **Readings display**

- MAINS(Vre), GEN(Vge), Hz, BATT (Vcc) and HOURS LED's are switched on by pushing the /MIS key, indicating the relative reading on the display.
- The displayed readings are: mains voltage, generator voltage, generator frequency, battery voltage and the operating hours of the generating set. Mains and generator voltages are expressed as RMS (root-mean-square) values.
- The reading accuracy of the mains and generator voltages is 1VAC, 0.1Hz for generator frequency, 0.1VDC for battery voltage while 1 hour for the operating hours (true accuracy is 1 minute but it is not displayable).
- To display the voltages between line of the three-phase line, SELECT/MIS key is to be pressed three times. At each pressing, the LED corresponding to the voltage between lines will flash along with MAINS(Vre) LED.
- Usually the display visualizes the system voltage. When the motor is started up, the display automatically goes to the generating set voltage and vice versa. It is always possible to select the desired reading through the SELECT-MIS button.
- In case of alarm and temporary impossibility to remove the alarm, the readings can be displayed by pressing SELECT/MIS key for 3seconds. If it is not pressed again for 20 seconds, the display shows the previous alarm situation.

### **Operating hour counter of the generating set**

- Each time the engine is started, the hour counter for the operating minutes is activated.
- The operating time is however displayed in hours.
- The control unit keeps the accumulated operating time stored in lack of supply voltage.
- It is possible to modify and/or to alter the operating hours count through the following procedure:
- 1. Select reading "Operating hours" through button SELECT-MIS (LED HOUR on).
- 2. Push the RESET button for more than 5 seconds until HOU appears on the display.
- 3. With buttons START and STOP you can increase or decrease the count. By pushing them together, you automatically set the count to zero.
- 4. Push RESET to store and exit.

### **Maintenance interval**

- Each time the engine is started, the hour counter for the operating minutes for the maintenance requested interval (set up -16) of the generating set, expressed in minutes, is activated.
- Alarm code "A05" (Maintenance requested) is displayed and the audible alarm output is energized when the generating set reaches the programmed operating hours for the maintenance requested interval (set up -16).
- In presence of this alarm, the generating set can continue to operate normally but at each new starting the audible alarm output is energized.
- After having carried out maintenance on the generating set, the alarm is reset with the RESET button. This also zeroes the maintenance hour counter.
- If there is a power failure, the set keeps the operating time of the generating set relative to the maintenance interval in memory.

## FUNCTIONS

### **Automatic test**

- Automatic test is the periodic start-up testing of the generating set at fixed intervals programmable by means of the automatic test interval time (option P.11). It has the purpose of checking operation and/or keeping the generating set efficient. The duration of the testing is determined by the automatic test duration (option P.12), at the end of which the generating set is stopped.
- The beginning of automatic test is displayed by "A.tE" (Automatic test), if enabled and if programmed to energize the audible alarm output for 5 seconds. At its de-energizing and after a 3-second interval, the start-up cycle begins.
- During the test cycle, the load normally stays connected to the mains and there is no switchover.
- In the event of there being no mains voltage, the control unit automatically changes over the load to the generator. At the return of the mains voltage, the load remains on the generator.
- At the end of the automatic test, in the presence of mains voltage, the load is changed over to the mains and the generating set is stopped.
- Automatic test can take place if the unit is in AUT mode and is enabled.

### **Enabling and disabling the automatic test**

- The enable or disable function of automatic test does not influence the unit operation. Therefore, it can be done, at any moment, independent of the operating mode of the control unit.
- At the moment automatic test is enabled, a chronometer for the automatic test interval (option P.11), expressed in days, is activated. In this way, automatic test will regularly take place at its exact enabling time.
- To enter automatic test enable or disable function, push SELECT/MIS and keeping it pressed, then push TEST key. Either "OFF" will be displayed if the automatic test is disabled or, if pre-set, the number of days of the programmed automatic test interval (option P.11). Automatic test is enabled pressing START or disabled pushing STOP.
- If you want to change the test interval, please read the option menu chapter.
- Press RESET to exit the enable/disable functions of automatic test.
- During this function if no keys are pressed for 120 seconds, the control unit will automatically exit this function.

### **Emergency stop**

- The emergency stop input is to be connected to a NC contact otherwise the control unit will prevent all start attempts of the generating set.
- The emergency stop control (opening of the input contact) causes the immediate stopping of the generating set, independently of the operating state of the unit, without cooling time (option P.09), E01 alarm code (Emergency stop) appears on the display and the audible alarm output is energized.
- For alarm reset and audible alarm mute, the input contact of the emergency stop is to be necessarily pressing RESET.

### **Remote starting**

- In AUT mode, remote or external starting is enabled.
- The remote starting control of the generating set is shown with "E.St" (External start) display and, if preset, the audible alarm output is energized for 5 seconds. When the audible alarm output is de-energized after a 3-second interval, the start-up cycle begins.
- The control unit automatically changes the load over to the generator when the generating set is running and there is a lack of mains voltage.
- By removing the remote starting control, with mains voltage present, the load is changed over to the mains and the

generating set is stopped. On the other hand, if the mains voltage is absent, the generating set continues to regularly operate supplying the load.

### **Remote stop**

- When, in the AUT mode, the remote start-up inlet is closed, the equipment carried out the instantaneous opening of the generating set switch and the stop of the cooling cycle group.
- The automatic start-up is inhibited. The display visualizes the corresponding code (E03 External stop).
- Automatic re-activation with inlet opening.
- For the operations requiring a connection of a floating contact, this inlet avail itself of an anti-bounce filter that allows for the signal to be changed over with a time not lower than 5 seconds.

### **EJP function**

- The EJP function can be activated through the set-up -03 parameter.
- When this function is activated, the remote start-up inlet is reprogrammed as EJP start ; the stop inlet is reprogrammed as EJP change-over approval.
- When the start inlet is activated, the motor start-up delays after EJP start (option P13) is also activated. At the end of it, the start-up cycle is carried out. During that time, the display will visualize EJP.
- Then, when the changeover approval arrives (only if the motor has started up regularly), the mains/generator exchange is carried out.
- The load comes back to the mains after the changeover approval opening; the group performs the stop cycle at the opening of the start inlet.
- The EJP function is only enabled when the system is in automatic mode.
- Protection devices and alarms work as usual.

### **EJP/T function**

- The EJP function is a simplified version of the preceding EJP. The motor start-up is controlled in the same way but the load changeover is carried out through a time delay and not through a special external signal. This function only uses one digital entry (external start).
- The delay time in order for the changeover to be performed starts when the start-up control is closed; it is programmable through the following parameter: changeover delay for EJP/T (option P14).
- In order to select the EJP/T function please program parameter set-up -03.

### **SCR function**

- The SCR function is very much like the preceding EJP function; you can program it by setting the set-up -03 value to 2.
- In this mode the external start entry allows for the start-up of the group as in EJP but without waiting for the delay time.
- The stop entry still has the changeover approval function; the difference with the EJP function is that changeover takes place after the generating set voltage presence delay (option P08).

### **Motorized pump operation**

- In the motorized pump applications it is possible to use the following parameter: no mains intervention disabling (set-up -04). It disables the mains voltage control and the generating set no voltage alarm.
- With this kind of operation, the motorized pump group start-up can be controlled either through the MAN mode (with START or STOP buttons) or through the AUT mode (with the external start signals and external stop).
- It is also possible to program the set-up -04 parameter so that the equipment detects alarms as usual or in such a way as to be able to visualize alarms without ever stopping the group

**Decelerator function**

- If the deceleration exit is available, this is activated as soon as the motor has started up; it is inactivated at the end of the decelerated operation time (set-up -18).
- This function can be enabled as an alternative to the stop magnet and to the pre-heat spark plugs. The choice is made through the following parameter: programmable relay 1 function (set-up -17).

**Gas solenoid valve function**

- During the starting cycle, if a gas solenoid valve output has been provided for, this is activated after the gas solenoid valve energizing delay (set up -30) by the activation of the starting output. The gas solenoid valve output stays activated while the motor is running.
- When the motor needs to be stopped, the gas solenoid valve output is deactivated 3 seconds before running approval is removed (fuel solenoid valve).

**Starter function**

- The starter function relay is activated with the excitation of the gas solenoid valve during the first attempt to start the motor only.
- It stays excited for a time that can be adjusted through the following parameter: starter time length (set-up -31).
- This function can be programmed onto the programmable relay 2 as an alternative to the fuel solenoid valve or air function (through parameter set-up -28).

**Air function**

- The air function relay is activated two seconds before activating the starter (only for the first three start-up attempts). It stays closed for a maximum time that can be adjusted through parameter airtime length (set-up -32).
- If the motor starts up, the air relay is inactivated as soon as the generating set voltage goes over the air inactivation threshold (set-up -33).
- This function can be programmed onto the programmable relay 2 as an alternative to the fuel solenoid valve and to the starter function (through parameter set-up -28).

**REMOTE CONTROL**

- X803 in its version with serial interface RS485 (ordering code .....), is capable of talking to a PC (or intelligent terminal) to carry on functions of remote control and supervision.
- To ensure correct operation and reliability in an industrial environment, the set's RS485 interface is galvanically isolated.
- The link between the PC and RS485 interface of the X803 is made with a galvanically isolated RS232-RS485 converter with automatic control of the enable line.
- X803. /RC is supplied with: PC/Windows supervision software diskette, supervision software user manual and communication protocol manual.
- The RS232-RS485 converter can be supplied separately, code: 4XC22348T
- Technical data of the RS485 serial interface:
  - Half-Duplex communication with 2 wires (braided pair with end resistors)
  - Mutidrop configuration with the possibility of linking up to 32 stations
  - Transmission format 9600 baud, 8 bit data, 1 stop bit, no parity
  - Maximum length of communication line 1000m
- Main technical features of supervision software:
  - Total control of operator panel (front of X803)
  - Possibility of remote control by modem with no restriction
  - Graphic and numerical display of all readings
  - Alarm status display
  - Display of status of all inputs and outputs
  - Display of events with data and time (events-log)
  - Possibility of displaying, editing, saving and/or loading the set up and option data from files
  - Possibility of accessing the operating manual on-line.

**INFORMATION - ALARMS - ERRORS**

**Information**

The information codes on the display indicate a few of the most important activities of the control unit.

Messages table		
Code	Meaning	Display condition
<b>StA</b>	Start	During the start-up cycle of the generating set
<b>Sto</b>	Stop	During the stopping of the generating set after the cooling time
<b>A.tE</b>	Automatic test	During the automatic test cycle
<b>E.St</b>	Remote starting	With remote starting signal
<b>EJP</b>	EJP function	When the EJP start entry is active and the system is in automatic mode
<b>Scr</b>	SCR function	When the SCR start entry is active and the system is in automatic mode

## Alarms

The alarm codes on the display indicate conditions or situations why the generating set can or could not provide energy.

### A01 HIGH TEMPERATURE

When the engine is running, it is displayed, after alarm trip delay (set up -08), when the input contact of the engine temperature is closed. The tripping de-energizes the generator contact output and immediately stops the generating set, without any cooling.

### A02 LOW OIL PRESSURE

With the engine is running, it is displayed, after alarm trip delay, when the input contact of the pressure switch is closed. The tripping de-energizes the generator contact output and immediately stops the generating set, without any cooling.

### A03 BATTERY CHARGER ALTERNATOR FAILURE

This is activated with motor running (voltage and/or frequency of generator). The alternator battery charge signal remains under the motor running voltage threshold (set up -06) for longer than the battery charger alternator fault delay (set up -14). This alarm stops the generating set.

### A04 UNEXPECTED STOP

This alarm is activated when the motor stops without external intervention having caused the shut down

### A05 MAINTENANCE REQUESTED

This is enabled when the minute counter of the maintenance interval reaches the programmed Maintenance interval duration (set up -16). To reset the alarm and counter, go into the RESET mode. With this alarm the set continues to run properly.

### A06 GENERATOR OVER FREQUENCY

This is activated when the generating set frequency (depending on the motor's number of revolutions) is 10% higher than the nominal value. This condition has to last for a time whose length is inversely proportional to the importance of the over frequency. This time interval can last for a maximum of 4 seconds (frequency +10% if compared with nominal value) down to a minimum of 0 seconds (immediate intervention when frequency is + 20% if compared with the nominal value). We remind you that the nominal frequency can be chosen between 50 and 60 Hertz through the following parameter: nominal frequency (set-up -01). The intervention of this alarm inactivates the output of the generating set's disconnecting switch and the immediately stops the generating set without cooling down. This alarm can also be inactivated through the following parameter: top frequency alarm inactivation (set-up -34).

### A07 LOW FUEL LEVEL

This is caused by the contact closing of fuel level input. The alarm can be configured to stop the set or not with the external alarm A07 (set up -22).

### A08 - USER ALARM

This is generated by the closing of the contact on the relevant input. This alarm can be programmed in order to stop the set or not through the external alarm A08 (set-up -23).

### A09 - USER ALARM

This is generated by the closing of the contact on the relevant input.

This alarm can be programmed in order to stop the set or not through the external alarm A09 (set-up -24).

### A10 STARTING FAILURE

This is displayed when the number of starting attempts (set up -10) are carried out and the engine is not yet running.

### A11 GENERATOR UNDER FREQUENCY

Activates when, with the alarms on (the motor running for longer than the alarm delay set up -08) and with the decelerator output deactivated, the generator frequency (depending on the number of motor spins) is inferior to the minimum frequency alarm threshold (set up -41) that lasts longer than the generator voltage absence delay (option P.07). Activation deactivates the generator contact output and immediately stops the generator set without cooling.

### A12 LOW BATTERY VOLTAGE

This is displayed when battery voltage is below the low battery voltage alarm threshold (set up -39). During the starting output energizing, this alarm is temporarily disabled. The alarm resetting threshold is 5% higher than the preset value. The battery voltage is controlled at the unit supply terminals. Any disparity between the displayed voltage and the one detected at the battery terminals is to be attributed to a voltage drop in the supply cables.

### A13 HIGH BATTERY VOLTAGE

Activates when the battery voltage increases over the maximum battery voltage alarm threshold (set up -40). The alarm threshold resets at 5% inferior to that which is programmed. Battery voltage is controlled on the machine terminals. A contingent discordance between the voltage visualized and that controlled on the terminals is due to a voltage drop in the supply wires.

### E01 EMERGENCY STOP

Activated by one of the following causes:

- 1) Opening of the contact connected to the emergency stop input.
- 2) Opening of the contact connected to the external stop input, if this has been programmed NC on the parameter set up -25.
- 3) Pressing the STOP button on the front panel when the system is in AUT mode

This alarm causes the set to stop immediately without cooling.

### E03 EXTERNAL STOP

This is activated when the contact on the external stop is closed in AUT mode. This alarm provokes the immediate functioning of the generator remote control switch and main stop with cooling cycle. For applications that provide a connection with a floating device, an anti-ricochet filter has been inserted that permits the commutation of the signal with a maximum time of 5 seconds.

### E04 GENERATOR VOLTAGE FAILURE

Activates when the generator voltage is not within the provided limits of the alarm enable delay E04 (set up -38) with the generator set functioning in a non-decelerating mode. Activation disables the generator contact output and immediately stops the generator set without cooling.



ALARM SUMMARY TABLE						
Code	Description	Retentive	Immediate Stop	Cooling Stop	Alarm G activated	Siren activated
A01	High temperature	YES	YES		YES	YES
A02	Low oil pressure	YES	YES		YES	YES
A03	Alt charge B. 500 failure	YES	YES		YES	YES
A04	Unexpected Stop (MECHANICAL ALARM)	YES	YES		YES	YES
A05	Maintenance requested	YES			YES	YES
A06	Generator over frequency	YES	YES		YES	YES
A07	Prog. 7/fuel level	Prog	Prog.	Prog.	Prog	Prog
A08	Prog. 8	Prog	Prog.	Prog.	Prog	Prog
A09	Prog. 9	Prog	Prog.	Prog.	Prog	Prog
A10	Starting failure	YES	YES		YES	YES
A11	Generator under frequency	YES	YES		YES	YES
A12	Low battery voltage	YES			YES	YES
A13	High battery voltage	YES			YES	YES
E01	Emergency Stop	YES	YES		YES	YES
E03	External Stop			YES		
E04	Generator voltage failure	YES	YES		YES	YES

### Errors

The displayed error codes indicate an operation fault or anomaly of the program memories and of the preset parameters.

ERRORS TABLE		
Code	Meaning	Display condition
IE1	Internal error, incorrect program	Alteration of the program memory. Return the X803 to Miami Breaker for repair; ask for authorization beforehand.
IE2	Internal error, incorrect parameters	Alteration of parameter memory. Remove X803 supply; resupply and check all parameters. In case the IE2 error persists, return the X803 to Miami Breaker for repair; ask for authorization beforehand.

### INPUTS AND OUTPUTS

Inputs table (alarm and control)					
Terminal No.	Function	Alternative function No. 1	Alternative function No. 2	Alternative function No. 3	Parameter reference
3	High temperature sensors				
4	Oil pressure sensor				
5	External stop	EJP COMMUT.	SCR COMMUT.	EMERGENCY STOP	SETUP 03 SETUP 25
6	External Start	EJP START	SCR START		SETUP 03
35	Low fuel level A07	PROG.	PROG.		SETUP 22
36	Programmable Alarm A08	PROG.	PROG.		SETUP 23
37	Programmable Alarm A09	PORG.	PROG.		SETUP 24
41	Emergency Stop				

### OUTPUT TABLE

Terminal No.	Function	Alternative function No. 1	Alternative function No. 2	Parameter Reference
14	Start			
16	Stop	Deceleration	Glow plug	Setup 17
17	Fuel Valve	Starter function	Air	Set up 28
18	Siren			
29,30	Mains Contactor			
31,32	Generator Contactor			
33,34,34C	General Alarm	Gas SV-EV		Set up -29

## PROGRAMMING

- The parameter setting is done by accessing two different menus: option and set up.
- **Option:** In this menu the parameters are set in relation to the mains characteristics and user requirements. Normally, the setting of these parameters is done by the installer of the generating set.
- To access the Option menu, place the unit in RESET mode and keep the RESET key pressed then push the SELECT/MIS key for 5 seconds. Access to the Option menu is displayed with "P.01" indicating the setting to be modified.
- **Set up:** In this menu the parameters are set in close relation to the generating set characteristics. Normally, setting these parameters is reserved to the manufacturer of the generating set and/or control panel.
- To access the Set up menu, place the unit in RESET mode and, keeping the RESET key pressed, press the START button twice, the STOP button 3 times and SELECT/MIS 4 times. Now release the RESET button. The display will show Set. Press Start to access the first parameter, indicated by code -01.
- In the set up function, to access the subsequent parameter, press GEN(TLG), while for the previous one, presses MAINS(TLR). After having selected the required parameter, to increase the value, press STOP or, to decrease, press START. The variation can be made only within the foreseen limits. To store the set parameters, press the RESET key.

## PARAMETERS

The following tables group the Option and Set up parameters. RANGE indicates the field of possible settings, DEFAULT the classic setting of a board straight after leaving the factor. It is recommended to attach a table to each electrical panel showing the settings associated with that type of panel.

### Menu Option

Option	Description	Range	Default
P.01	Minimum mains voltage trip threshold	80 – 480 VAC (3 phase) 160 – 230 VAC (Mono phase)	340 VAC (three phase)
P.02	Maximum mains voltage trip threshold	110 – 600 VAC (three phase) 253 – 345 VAC (mono phase)	480 VAC (three phase)
P.03	Mains voltage absence delay	0-120 sec	5 sec
P.04	Mains voltage presence delay	0-240 sec	10 sec
P.05	Minimum generator voltage trip threshold	80 – 480 VAC (three phase) 160 – 230 VAC (mono phase)	340 VAC (three phase)
P.06	Maximum generator voltage trip threshold	110 – 600 VAC (three phase) 253 – 345 VAC (mono phase)	480 VAC (three phase)
P.07	Generator voltage absence delay	1-180 sec	5 sec
P.08	Generator voltage presence delay (generator contact closing delay)	1-180sec	20 sec
P.09	Cooling duration	1 – 300 sec	30 sec
P.10	Audible alarm duration	0-60 sec	20 sec
P.11	Automatic test interval	1 - 7 days	3 days
P.12	Automatic test duration	1-30 min	10 min
P.13	Engine start delay after EJP start	0 – 99 min	25 min
P.14	EJP/T commutation delay (1 wire)	0-30 min	5 min

### Set up menu (the password is only for skilled personnel)

Set up	Description	Range	Default
-01	Rated frequency generator	0(50Hz)-(60 Hz)	0
-02	Started engine signal source	0(disabled)-1(activated)	1
-03	Normal function EJP-SCR-EJP/T	0(nor) 1(EJP) 2(SCR) 3(EJP/T)	0

Set up	Description	Range	Default
-04	Voltage control exclusion (for pump)	0(nor) – 1(alarm stop pump)-2(no alarm stop p.)	0
-05	500RPM signal select (C.B. alternator or generator)	0 (alt) – 1(gen)	0
-06	Alternator tension threshold for motor start up	6 – 60V	10 V
-07	Generator tension threshold for motor start up	5 – 200 VAC	10 VAC
-08	Alarm enable delay at engine starting	1 – 60 sec	15sec
-09	Stop duration	1-30sec	20 sec
-10	Number of starting attempts	1-10	5
-11	Starting attempt duration	1-30sec	5 sec
-12	Interval between starting attempts	1-20sec	10 sec
-13	Delay between interrupted and subsequent startings	2 - 5sec	3 sec
-14	Delay 500 RPM failure enable	2 – 5 sec	3 sec
-15	Mains/Generator interlock delay	0-10sec/10	5 sec/10
-16	Maintenance interval	10 – 250 hours	50 hours
-17	Function exit born 16-0(electromanet1 (accelerator) 2(preheating)	0 (nor) – 1(acc) 2(preheating)	0
-18	Deceleration duration	1 – 180 sec	60
-19	Spark plug heating time	1 – 60 sec	10 sec
-20	Automatic test activation with external stop activated	0 (disabled) – 1(activated)	0
-21	Disable AUT and TEST (paper functions only in MAN or OFF)	0 (nor) – (disabled)	0
-22	External alarm A07 (disable /alarm only/alarm and stop)	0(disabled) 1(alarm) 2(stop)	0
-23	External alarm A08 (disable /alarm only/alarm and stop)	0(disabled) 1(alarm) 2(stop)	0
-24	External alarm A09 (disable /alarm only/alarm and stop)	0(disabled) 1(alarm) 2(stop)	0
-25	External stop NF over ride NO	0(NO) 1 (NF)	0
-26	Additional delay for alarm A08 (from alarm start)	0 – 120 sec	0
-27	Serial communications address	01 - 32	01
-28	Program 2 (fuel/Advance/Air)	0(fuel) 1 (Ad) 2 (Air)	0(fuel)
-29	Program 3 (general alarm/Gas)	0 (alarm) – 1 (Gas)	0(alarm)
-30	Gas delay (after start)	1 – 5 sec	2 sec
-31	Advance duration	1 – 10 sec	5sec
-32	Air duration	0 – 10 sec	8 sec
-33	Air transmission brake threshold	0 – 200 V	8 V
-34	Maximum frequency alarm disable (A06)	0 (act) 1 (disable)	0 (act)
-35	Disable alarm with generator voltage absence (E04)	0 (act) 1(disable)	0 (act)
-36	New commutation main block during EJP alarm	0 (nor) 1 (block)	0 (nor)
-37	Mono phase / Three phase line	0 (mono) 1 (three)	1 (three)
-38	Alarm enable E04 (generator voltage absence)	15 – 240 sec	240 sec
-39	Minimum battery voltage	7 – 12 VDC (12V) 13 – 24 VDC (24V)	9V (12V) 18V (24V)
-40	Maximum battery voltage	13 – 17 VDC (12V) 26 – 34 VDC (24V)	16V (12V) 32V (24V)
-41	Minimum frequency alarm threshold	20-50/60Hz	40Hz
-42	Maximum main asymmetry	5 – 20 %	15%

## TECHNICAL CHARACTERISTICS

<b>- Supply circuit</b>	
Battery supply (Us)	12Vcc o 24Vcc 12Vdc or 24Vdc
Maximum current consumption	≈ 160mA (250mA con RS485) ≈ 160mA (250mA with RS485)
Stand-by current	≈ 110mA (200mA con RS485) ≈ 110mA (200mA with RS485)
Operating range 12V	6,2÷16,5 Vcc 6.2-16.5Vdc
Operating range 24V	13÷33 Vcc 13-33Vdc
Immunity time for micro breakings	≈ 150ms
Maximum ripple	10%

<b>- Mains voltage control circuit (single or three phase)</b>	
Rated voltage (Ue)	100÷480Vca 100-480Vac
Operating range	70÷624Vca 70-624Vac
Rated frequency (keyboard adjusted)	50/60Hz
Minimum voltage tripping (keyboard adjusted)	0,7÷1Ue 0.7-1Ue
Maximum voltage tripping (keyboard adjusted)	1÷1,5Ue 1-1.5Ue
Asymmetry tripping (only three-phase)	5÷20% Ue 5-20Ue
Resetting hysteresis	5%
Precision Accuracy	±1%

<b>- Generator voltage control circuit (single phase)</b>	
Rated voltage (Ue)	100÷480Vca 100-480Vac
Operating range	70÷624Vca 70-624Vac
Rated frequency (keyboard adjusted)	50/60Hz
Minimum voltage tripping (keyboard adjusted)	0,7÷1Ue 0.7-1Ue
Maximum voltage tripping (keyboard adjusted)	1÷1,5Ue 1-1.5Ue
Resetting hysteresis	5%
Accuracy	±1%

<b>- Remote control circuit</b>	
Input	negative
Voltage applied at contacts	12Vcc (24Vcc) 12Vdc (24Vdc) battery
Maximum current	8mA

<b>- Started engine control circuit</b>		
- Battery charger permanent magnet alternator		
Operating range	0-40Vca 0-40Vac	
Adjustment range	6-30Vca 6-30Vac	
Input current	<10mA	
- Battery charger energised alternator		
Operating range	0-40Vcc 0-40Vdc	
Adjustment range	6-30Vcc 6-30Vdc	
Maximum input current	<10mA	
+D Circuit voltage	12Vcc (24Vcc) 12Vdc (24Vdc) battery	
Energising current	Ue 12Vcc Ue 12Vdc	170mA
Energising current	Ue 24Vcc Ue 24Vdc	130mA

<b>- Output relay contacts to exclude mains, Generator and Audible Alarm</b>	
arrangement	1 NO contact
Rated operational voltage	24Vdc
Maximum operational voltages	30Vdc
Rated capacity lth	5A
Rated capacity DC13 (or DC14)	5A-24Vdc

<b>- Output relay contacts of common alarm</b>	
Contact arrangement	1 changeover contact
Rated operational voltage	24Vcc 24Vdc
Maximum operational voltage	125Vac 30Vdc
Rated capacity lth	5A
Rated capacity DC13 (or DC14)	5A-24Vdc

<b>- Output contacts of Mains and Generator contactors</b>	
Mains contactor control	1 NC contact 1 NO contact
Generator contactor control	1 NO contact
Rated operational voltage	250Vac
Maximum operating voltage	440Vac
Rated capacity lth	5A
Rated capacity AC15	2A 220Vac
Contacts/coil insulation	5kVac 1min
Open contacts insulation	1kVac 1min

**Other characteristics**

<b>- Enclosure</b>	
Version	Incasso Flush mount
Overall dimensions l x h x d	144x144x125mm
Degree of protection without protective cover	IP41
Degree of protection with protective cover	IP54
Weight	≈880g

<b>- Operating ambient conditions</b>	
Operating temperature	0÷60°C 0-60°C
Storage temperature	-30÷80°C -30 to +80°C

<b>- Connections</b>	
Type of terminals	Estraibile Plug in
Cable cross-section	2,5mmq 2.5mmsq

**REFERENCE STANDARDS**

- **Dielectric test (IEC255-5)**  
 Industrial frequency (50Hz) : 2.5kV for one minute  
 Impulse (1.2/50ms): 5kV (3 positive and 3 negative at intervals longer than 5 seconds)
- **Climatic sequence (IEC 68-2-61)**  
 Method 1: hot dry, hot damp, cold, hot damp
- **Vibration test (IEC 68-2-6 or according to Lloyd's Register specifications)**  
 Fc test (sinusoidal vibrations)
- **Damp-saline ambient test (RINA specifications)**
- **Electromagnetic compatibility test (EN 50081-1, EN 50082-2)**  
 Electrostatic discharge immunity (EN 61000-4-2)  
 Fast transient / burst immunity (EN 61000-4-4)  
 Radiated radio-frequency electromagnetic field immunity (ENV 50140)  
 Conducted radio disturbance electromagnetic field immunity (ENV 50141)  
 Emission level of radiated electromagnetic fields (EN 55011)  
 Emission level of conducted electromagnetic fields (EN 55011)

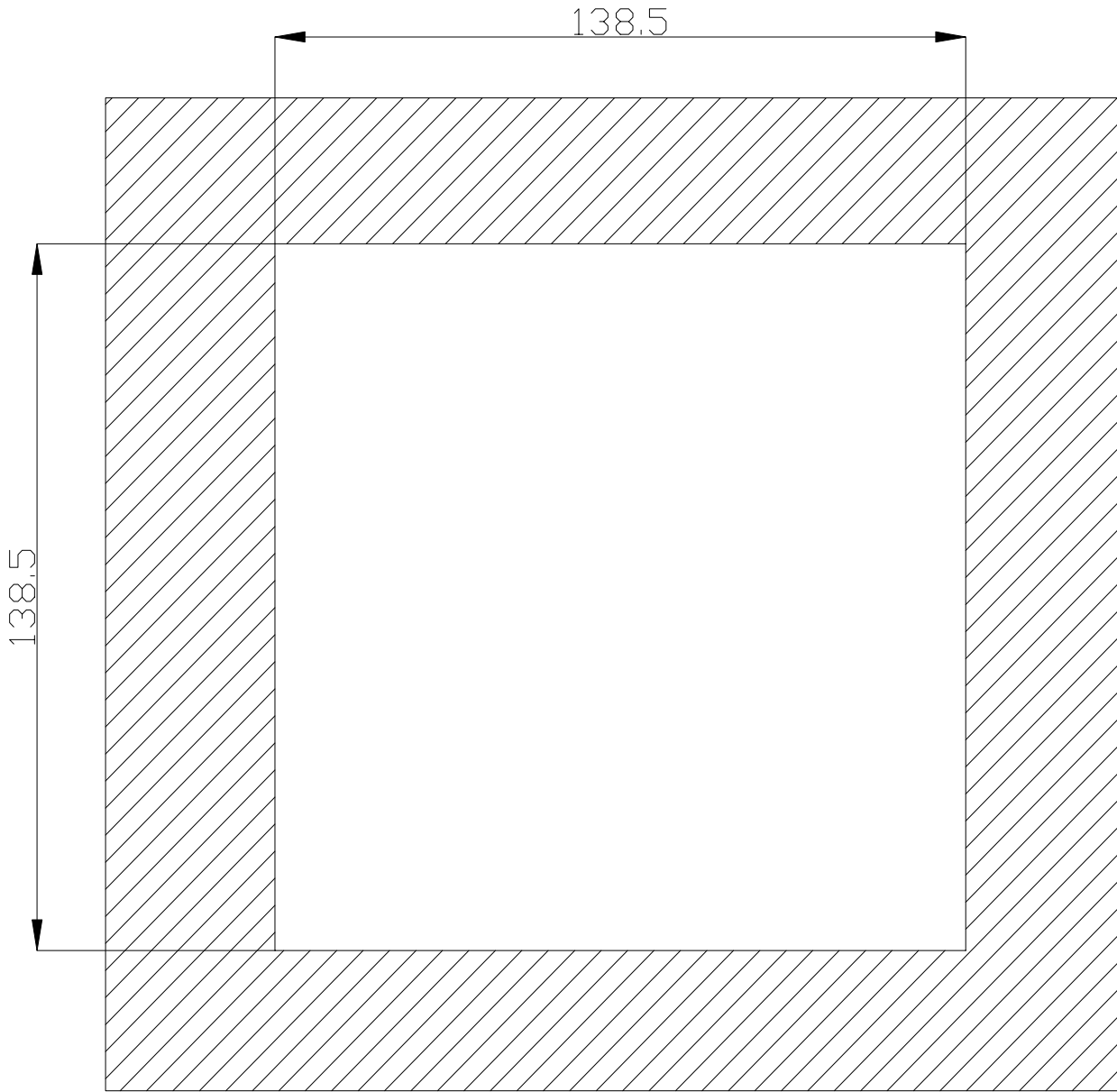

**CONNECTION ONLY FOR ENGINES  
 WITH BATTERY CHARGER ALTERNATOR  
 MODEL.SAPRISA**

