

2

1

REV	DESCRIPTION	DATE	APPROVED

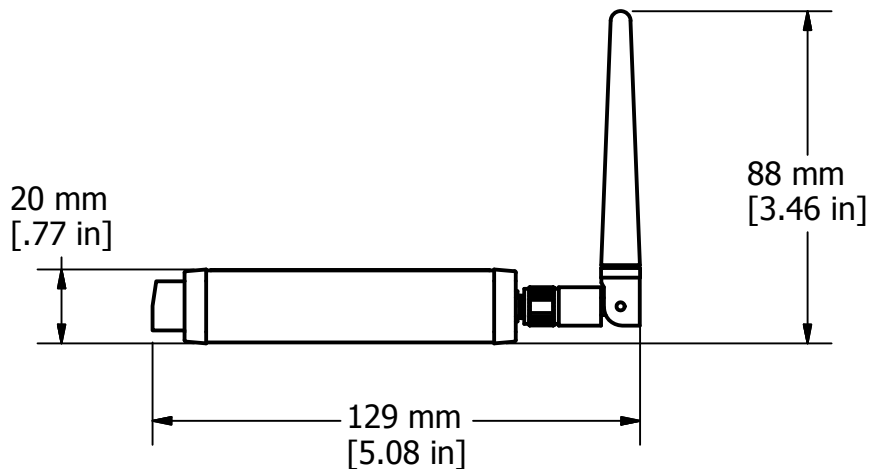
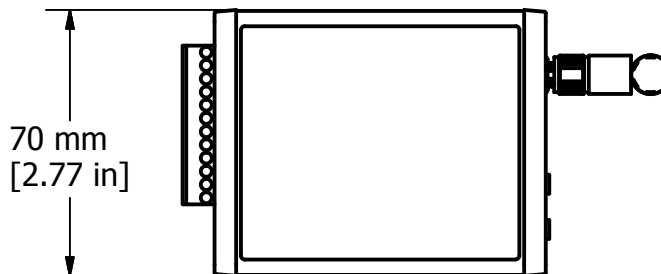

UNLESS OTHERWISE SPECIFIED ALL DIMENSIONS ARE IN INCHES.  
 TOLERANCES:(UOS):  
 .X = ± .02; .XX = ± .01; .XXX = ± .005  
 HOLE DIAMETERS: ± .002; ANGLES: ± 0.5°  
 SURFACE FINISH: 63 MICROINCHES  
 MATERIAL:  
 -

**MicroStrain®** 459 Hurricane Lane, Suite 102  
 Williston, VT 05495  
 802-862-6629

TITLE  
**WSDA-101**

DESIGNED BY:      DRAWN BY: TDA  
 CHECKED BY:      APPROVED BY:

SIZE A	CAGE CODE OXYZ9	DWG NO: <b>6307-1010</b>	REV -
SCALE 1/2		DATE: 1/24/2013	SHEET 1 OF 1

THIS DRAWING AND SPECIFICATIONS ARE THE PROPERTY OF MICROSTRAIN INC. AND SHALL NOT BE PRODUCED WITHOUT PERMISSION FROM MICROSTRAIN INC.

2

1