



HPS™ Products

HPS™ Series 937A

High Vacuum

Multi-Sensor System

OPERATION AND MAINTENANCE MANUAL



HPS™ Products

HPS™ Series 937 A

High Vacuum
Multi-Sensor System

August 1998
Part # 10009273 Rev. 4.0

Part # 937A- _____ - _____ - _____

Serial # _____

Please fill in these numbers and have them readily available when calling for service or additional information.
(The part number can be found on your packing slip, and the serial number is located on the rear of the housing.)

For more information or literature, contact:

**MKS Instruments, Inc., Vacuum Products Group
5330 Sterling Drive
Boulder, CO 80301 USA**

**Phone: 303-449-9861
 800-345-1967**

FAX: 303-442-6880

© 1998 by MKS Instruments, Inc., Vacuum Products Group, All rights reserved.

ALCONOX is a registered trademark of Alconox, Inc.
Baratron is a registered trademark of MKS Instruments, Inc.
Elgiloy is a registered trademark of Elgiloy Co.
HPS and IgniTorr are trademarks and I-MAG is a registered trademark of MKS Instruments, Inc., Vacuum Products Group
Inconel is a registered trademark of Inco Alloys International, Inc.
Scotch-Brite is a trademark of 3M.
Teflon and Viton are a registered trademarks of DuPont Co.
VCR® is a registered trademark of Swagelok® Company.

TABLE OF CONTENTS

TABLE OF CONTENTS

PACKAGE CONTENTS	1
SAFETY INFORMATION	2
Symbols	2
Symbols Used in this Manual (English)	2
Symboles utilisés dans ce manuel (Français)	2
In dieser Betriebsanleitung vorkommende Symbole (Deutsch)	3
Símbolos Usados en el Manual (Español)	3
Symbol Definitions	4
Definition of Symbols Found on the Unit (English)	4
Définition des symboles apparaissant sur l'appareil (Français)	4
Definitionen der am Gerät angebrachten Symbole (Deutsch)	5
Símbolos que Aparecen en la Unidad (Español)	5
Safety Precautions	6
Safety Procedures and Precautions (English)	6
Sicherheitsvorschriften und Vorsichtsmaßnahmen (Deutsch)	10
Procedimientos y Precauciones de Seguridad (Español)	12
SPECIFICATIONS*	14
Controller	14
Sensors	17
FEATURE AND CONTROL LOCATIONS	22
TYPICAL APPLICATIONS FOR THE SERIES 937A	24
HPS™ Products Series 937A Multi-Sensor High Vacuum System	25
Set Points	26
Leak Test	26
Analog Output Signals	26
Computer Interface	26
Setting Up the Series 937A Controller	27
Removing a Module	27

Configuring a Module	27
Sensor Modules	27
Cold Cathode	28
Pirani	28
Convection Pirani	29
Capacitance Manometer	29
Thermocouple	30
Analog Module	30
Pressure Units – Switches 1 and 2	30
Control/Combination Sensor Channels– Switches 3 and 4	30
Line Frequency – Switch 5	31
Cold Cathode Sensor Delay – Switch 6	31
Configuration-Switch 7	31
UCAL Enable/Disable	31
RS-232/RS-485 Communications Module (Optional)	31
Power Supply Module	33
Installing a Module	33
Panel Labels	34
Mounting the Controller	34
AC Power Cord	35
OPERATING THE SERIES 937A CONTROLLER	36
Power	36
Display	36
Using the Front Panel Controls	38
Using Function Select	39
Display Test Mode	39
Reviewing Controller Setup	39
Setup Review Screen 1	39
Cold Cathode non-Standard Configuration Codes	40
Setup Review Screen 2	41
Setup Review Screen 3	41
Setup Review Screen 4	42
Setup Review Screen 5	42
Setup Review Screen 6	42
Setup Review Screen 7	43
Pressure Mode	43
Cold Cathode Sensor High Voltage	44
Front Panel Control Lock	44
Leak Test Mode	45
Relay Set Points Mode	46
Reading a Relay Set Point	46
Setting a Relay Set Point	46
Disabling a Relay Set Point	47
Relay Inductive Loads and Arc Suppression	47
Protection and Control Set Points Mode	48
Setting a Protection Set Point	48
Setting a Control Set Point	48
Protection and Control Set Point Display Messages	49
Protection and Control Set Point Messages	49
Disabling a Protection or Control Set Point	50
Zero and ATM Calibration Modes	50
Zero Calibration Mode	51
Capacitance Manometer Auto-Zero Feature	52
ATM Calibration Mode	53
Calibrating the Convection Pirani Sensor for Atmosphere	54
Method 1	54
Method 2	54
Cold Cathode Operation	55

C.C. On/C.C. Off Front Panel Push-Buttons	56
Cold Cathode Module Remote Connector	56
Analog Module	56
Communications Module (optional)	56
Using Protection and Control Set Points	57
Determining Protection and Control Set Points	58
Information Update Rate	59
Controller Analog Output	60
Buffered Output	60
Logarithmic Output	61
Combination Logarithmic Output	62
Error Messages	63
Main Program Checksum Test	63
Communications Module Program Checksum Test	63
Nonvolatile Memory Error in Correction Factors	63
Setup Error	64
Quick Reference Tables	65
Table I Front Panel Operation	65
Table II Setpoint Values	66
Relay Setpoints	66
Control Setpoints	66
Protection Setpoint	66
SPARE PARTS AND ACCESSORIES	67
PRODUCT WARRANTY	70
Notes	71
APPENDIX A: INSTALLING A SERIES 937A SENSOR	A.1
Cold Cathode Sensors	A.1
General	A.1
Locating a Cold Cathode Sensor	A.1
Orienting a Cold Cathode Sensor	A.1
Managing Contamination in a Cold Cathode Sensor	A.2
Testing a Cold Cathode Sensor	A.2
Series 423 I-MAG® Cold Cathode Sensor	A.2
Connecting the I-MAG Sensor	A.2
Disassembling the I-MAG Sensor	A.2
Cleaning the I-MAG Sensor	A.3
Assembling the I-MAG Sensor	A.5
Preparing the Sensor for Bakeout	A.6
Series 421 Cold Cathode Sensor	A.6
Connecting the Series 421 Sensor	A.6
Disassembling the Series 421 Sensor	A.6
Cleaning the Series 421 Sensor	A.8
Assembling the Series 421 Sensor	A.9
Preparing the Sensor for Bakeout	A.9
Pirani Sensors	A.9
General	A.9
Locating a Pirani Sensor	A.9
Preventing Contamination in a Pirani Sensor	A.10
Series 315/345 Pirani Sensor	A.10
Orienting the Series 315/345 Pirani Sensor	A.10
Connecting the Series 315/345 Sensor	A.10
Cleaning the Series 315/345 Sensor	A.12
Testing the Series 315/345 Sensor	A.12

Series 317 Convection Pirani Sensor	A.12
Orienting the Series 317 Sensor	A.12
Connecting the Series 317 Sensor	A.13
Cleaning the Series 317 Sensor	A.15
Testing the Series 317 Sensor	A.15
Preparing the 317 Sensor for Bakeout	A.15
Capacitance Manometer MKS Baratron®	A.16
General	A.16
Installing the Baratron Capacitance Manometer	A.16
Connecting the Baratron™ Capacitance Manometer	A.16
Repairing the Baratron™ Capacitance Manometer	A.17
Thermocouple Sensor	A.18
General	A.18
Orienting the DV-6M Sensor	A.18
Connecting the DV-6M Sensor	A.18
Cleaning the DV-6M Sensor	A.19
APPENDIX B: LEAK TESTING WITH THE SERIES 937A	B.1
APPENDIX C: 937A SENSOR OUTPUT VS. PRESSURE CURVES	C.1
Buffered Analog Output Cold Cathode (Series 421 and 423)	C.1
Buffered Analog Output Pirani (Series 315 and 345)	C.2
Buffered Analog Output Convection Pirani (Series 317)	C.3
Buffered Analog Output Capacitance Manometer	C.4
Buffered Analog Output Thermocouple (DV-6M)	C.5
Logarithmic and Combination Output All Sensors	C.6

Package Contents

Before unpacking your Series 937A High Vacuum, Multi-Sensor System, check all surfaces of the package for shipping damage.

Please be sure that your Series 937A System package contains these items:

- ◆ 1 Series 937A Controller (with selected modules installed)
- ◆ 1 female, 9-pin "D" sub Accessory connector kit
- ◆ 1 10-foot power cord
- ◆ 1 *HPS™ Products Series 937A Multi-Sensor High Vacuum System* User's Manual.

If an optional communications module was ordered, a separate manual for the module should also be included with the package. The Series 937A System's sensors and their connecting cables are sold separately. Please refer to page 68 for necessary ordering information.



If any items are missing from the package, call HPS™ Products Customer Service at 1-303-449-9861 or 1-800-345-1967.

Inspect the Series 937A System for visible evidence of damage. If it has been damaged in shipping, notify the carrier immediately. Keep all shipping materials and packaging for claim verification. Do not return the product to MKS.

Safety Information

Symbols

Symbols Used in this Manual (English)

Symboles utilisés dans ce manuel (Français)

Definitions of CAUTION and NOTE messages used throughout the manual.

Définition des indications ATTENTION et REMARQUE utilisées dans ce manuel.



CAUTION: Risk of electrical shock. ISO 3864, No. B.3.6

ATTENTION: Risque de secousse électrique. ISO 3864, No. B.3.6



CAUTION: Refer to accompanying documents. ISO 3864, No. B.3.1

This sign denotes a hazard. It calls attention to a procedure, practice, condition, or the like, which, if not correctly performed or adhered to, could result in injury to personnel.

ATTENTION: **Se reporter à la documentation.** ISO 3864, No. B.3.1
L'indication signale un danger potentiel. Elle est destinée à attirer l'attention sur une procédure, une utilisation, une situation ou toute autre chose présentant un risque de blessure en cas d'exécution incorrecte ou de non-respect des consignes.



This sign denotes a hazard. It calls attention to an operating procedure, practice, or the like, which, if not correctly performed or adhered to, could result in damage to or destruction of all or part of the product.

L'indication signale un danger potentiel. Elle est destinée à attirer l'attention sur une procédure, une utilisation, une situation ou toute autre chose présentant un risque d'endommagement ou de dégât d'une partie ou de la totalité de l'appareil en cas d'exécution incorrecte ou de non-respect des consignes.



This sign denotes important information. It calls attention to a procedure, practice, condition, or the like, which is essential to highlight.

L'indication REMARQUE signale des informations importantes. Elle est destinée à attirer l'attention sur une procédure, une utilisation, une situation ou toute autre chose présentant un intérêt particulier.

In dieser Betriebsanleitung vorkommende Symbole (Deutsch)

Símbolos Usados en el Manual (Español)

Definition der mit VORSICHT! und HINWEIS überschriebenen Abschnitte in dieser Betriebsanleitung.

Definiciones de los mensajes de PRECAUCIÓN y OBSERVACIÓN usados en el manual.



VORSICHT! Stromschlaggefahr! ISO 3864, Nr. B.3.6

PRECAUCIÓN: Riesgo de descarga eléctrica. ISO 3864, N.º B.3.6



VORSICHT! Bitte Begleitdokumente lesen! ISO 3864, Nr. B.3.1

Das Symbol VORSICHT! weist auf eine Gefahrenquelle hin. Es macht auf einen Arbeitsablauf, eine Arbeitsweise, einen Zustand oder eine sonstige Gegebenheit aufmerksam, deren unsachgemäße Ausführung bzw. Ungenügende Berücksichtigung zu Körperverletzung führen kann.

PRECAUCIÓN: Consultar los documentos adjuntos. ISO 3864, N.º B.3.1

Este símbolo indica un riesgo. Pone de relieve un procedimiento, práctica, condición, etc., que, de no realizarse u observarse correctamente, podría causar lesiones a los empleados.



Das Symbol VORSICHT! weist auf eine Gefahrenquelle hin. Es macht auf einen Bedienungsablauf, eine Arbeitsweise oder eine sonstige Gegebenheit aufmerksam, deren unsachgemäße Ausführung bzw. Ungenügende Berücksichtigung zu einer Beschädigung oder Zerstörung des Produkts oder von Teilen des Produkts führen kann.

Este símbolo indica un riesgo. Pone de relieve un procedimiento, práctica, etc., de tipo operativo que, de no realizarse u observarse correctamente, podría causar desperfectos al instrumento, o llegar incluso a causar su destrucción total o parcial.

















Das Symbol HINWEIS weist auf eine wichtige Mitteilung hin, die auf einen Arbeitsablauf, eine Arbeitsweise, einen Zustand oder eine sonstige Gegebenheit von besonderer Wichtigkeit aufmerksam macht.

Este símbolo indica información de importancia. Pone de relieve un procedimiento, práctica, condición, etc., cuyo conocimiento resulta esencial.

Symbol Definitions















Definition of Symbols Found on the Unit (English)

Définition des symboles apparaissant sur l'appareil (Français)

	Caution refer to accompanying documents ISO 3864, No. B.3.1	Attention se reporter à la documentation ISO 3864, No. B.3.1
	Caution risk of electric shock ISO 3864, No. B.3.6	Attention risque de secousse électrique ISO 3864, No. B.3.6
	Caution hot surface IEC 417, No. 5041	Attention surface brûlante IEC 417, No. 5041
	On (Supply) IEC 417, No. 5007	Marche (mise sous tension) IEC 417, No. 5007
	Off (Supply) IEC 417, No. 5008	Arrêt (hors tension) IEC 417, No. 5008
	Earth (Ground) IEC 417, No. 5017	Terre IEC 417, No. 5017
	Protective Earth (Ground) IEC 417, No. 5019	Terre de protection IEC 417, No. 5019
	Direct Current IEC 417, No. 5031	Courant continu IEC 417, No. 5031
	Alternating Current IEC 417, No. 5032	Courant alternatif IEC 417, No. 5032
	Both Direct and Alternating Current IEC 417, No. 5033-a	Courant continu et alternatif IEC 417, No. 5033-a
	Three-phase Alternating Current IEC617-2, No. 020206	Courant alternatif triphasé IEC617-2, No. 020206
	Equipotentiality IEC 417, No. 5021	Equipotentialité IEC 417, No. 5021
	Frame or Chassis IEC 417, No. 5020	Masse, Châssis IEC 417, No. 5020
	Class II Equipment IEC 417, No. 5172-a	Matériel de la Classe II IEC 417, No. 5172-a

Definitionen der am Gerät angebrachten Symbole (Deutsch)

Símbolos que Aparecen en la Unidad (Español)

	Vorsicht! Bitte Begleitdokumente lesen! ISO 3864, Nr. B.3.1	Precaución Consultar los documentos adjuntos ISO 3864, N.º B.3.1
	Vorsicht! Stromschlaggefahr! ISO 3864, Nr. B.3.6	Precaución Riesgo de descarga eléctrica ISO 3864, N.º B.3.6
	Vorsicht! Heiße Fläche! IEC 417, Nr. 5041	Precaución Superficie caliente IEC 417, N.º 5041
	Ein (Netz) IEC 417, Nr. 5007	Encendido (alimentación eléctrica) IEC 417, N.º 5007
	Aus (Netz) IEC 417, Nr. 5008	Apagado (alimentación eléctrica) IEC 417, N.º 5008
	Erde IEC 417, Nr. 5017	Puesta a tierra IEC 417, N.º 5017
	Schutzleiter IEC 417, Nr. 5019	Protección a tierra IEC 417, N.º 5019
	Gleichstrom IEC 417, Nr. 5031	Corriente continua IEC 417, N.º 5031
	Wechselstrom IEC 417, Nr. 5032	Corriente alterna IEC 417, N.º 5032
	Wechselstrom und Gleichstrom IEC 417, Nr. 5033-a	Corriente continua y alterna IEC 417, N.º 5033-a
	Drehstrom IEC 617-2 Nr. 020206	Corriente alterna trifásica IEC 617-2 N.º 020206
	Äquipotentialanschluß IEC 417, Nr. 5021	Equipotencialidad IEC 417, N.º 5021
	Rahmen oder Chassis IEC 417, Nr. 5020	Caja o chasis IEC 417, N.º 5020
	Geräteklasse II IEC 417, Nr. 5172-a	Equipo de clase II IEC 417, N.º 5172-a

Safety Precautions

Safety Procedures and Precautions (English)

The following general safety precautions must be observed during all phases of operation of this instrument. Failure to comply with these precautions or with specific warnings elsewhere in this manual violates safety standards of intended use of the instrument and may impair the protection provided by the equipment. MKS Instruments, Inc. assumes no liability for the customer's failure to comply with these requirements.



Properly ground the Controller.

This product is grounded through the grounding conductor of the power cord. To avoid electrical shock, plug the power cord into a properly wired receptacle before connecting it to the product input or output terminals. A protective ground connection by way of the grounding conductor in the power cord is essential for safe operation.

Upon loss of the protective-ground connection, all accessible conductive parts (including knobs and controls that may appear to be insulating) can render an electrical shock.



Do not substitute parts or modify instrument.

Do not install substitute parts or perform any unauthorized modification to the instrument. Return the instrument to an MKS Calibration and Service Center for service and repair to ensure that all safety features are maintained.



Use proper electrical fittings.

Dangerous voltages are contained within this instrument. All electrical fittings and cables must be of the type specified, and in good condition. All electrical fittings must be properly connected and grounded.



The Series 937A Controller contains lethal voltages when on.

High voltage is present in the cable and a cold cathode sensor when the Controller is turned on.



Use the proper power source.

This product is intended to operate from a power source that applies a voltage between the supply conductors, or between either of the supply conductors and ground, not more than that specified in the manual.



Use the proper fuse.

Use only a fuse of the correct type, voltage rating, and current rating, as specified for your product.



Do not operate in explosive environments.

To avoid explosion, do not operate this product in an explosive environment unless it has been specifically certified for such operation.



Service by qualified personnel only.

Operating personnel must not remove instrument covers. Component replacement and internal adjustments must be made by qualified service personnel only.



Use the proper power cord.

Use only a power cord that is in good condition and which meets the input power requirements specified in the manual.

Use only a detachable cord set with conductors that have a cross-sectional area equal to or greater than 0.75 mm². The power cable should be approved by a qualified agency such as VDE, Semko, or SEV.

Mesures de Sécurité et Mises en Garde (Français)

Prendre toutes les précautions générales suivantes pendant toutes les phases d'utilisation de cet appareil. Le non-respect de ces précautions ou des avertissements contenus dans ce manuel entraîne une violation des normes de sécurité relatives à l'utilisation de l'appareil et le risque de réduire le niveau de protection fourni par l'appareil. MKS Instruments, Inc. ne prend aucune responsabilité pour les conséquences de tout non-respect des consignes de la part de ses clients.



Mise à la terre de l'appareil.

Cet appareil est mis à la terre à l'aide du fil de terre du cordon d'alimentation. Pour éviter tout risque de secousse électrique, brancher le cordon d'alimentation sur une prise de courant correctement câblée avant de le brancher sur les bornes d'entrée ou de sortie de l'appareil. Une mise à la terre de protection à l'aide du fil de terre du cordon d'alimentation est indispensable pour une utilisation sans danger de l'appareil.

En cas de défaut de terre, toutes les pièces conductrices accessibles (y compris les boutons de commande ou de réglage qui semblent être isolés) peuvent être source d'une secousse électrique.



Ne pas substituer des pièces ou modifier l'appareil.

Ne pas utiliser de pièces détachées autres que celles vendues par MKS Instruments, Inc. ou modifier l'appareil sans l'autorisation préalable de MKS Instruments, Inc. Renvoyer l'appareil à un centre d'étalonnage et de dépannage MKS pour tout dépannage ou réparation afin de s'assurer que tous les dispositifs de sécurité sont maintenus.



Mise à la terre et utilisation correcte d'accessoires électriques.

Des tensions dangereuses existent à l'intérieur de l'appareil. Tous les accessoires et les câbles électriques doivent être conformes au type spécifié et être en bon état. Tous les accessoires électriques doivent être correctement connectés et mis à la terre.



Danger de haute tension.

Une haute tension est présente dans le câble et dans le capteur lorsque le contrôleur est sous tension.



Utilisation d'une alimentation appropriée.

Cet appareil est conçu pour fonctionner en s'alimentant sur une source de courant électrique n'appliquant pas une tension entre les conducteurs d'alimentation, ou entre les conducteurs d'alimentation et le conducteur de terre, supérieure à celle spécifiée dans le manuel.



Utilisation d'un fusible approprié.

Utiliser uniquement un fusible conforme au type, à la tension nominale et au courant nominal spécifiés pour l'appareil.



Ne pas utiliser dans une atmosphère explosive.

Pour éviter tout risque d'explosion, ne pas utiliser l'appareil dans une atmosphère explosive à moins qu'il n'ait été approuvé pour une telle utilisation.



Dépannage effectué uniquement par un personnel qualifié.

L'opérateur de l'appareil ne doit pas enlever le capot de l'appareil. Le remplacement des composants et les réglages internes doivent être effectués uniquement par un personnel d'entretien qualifié.



Utilisation d'un cordon d'alimentation approprié.

Utiliser uniquement un cordon d'alimentation en bon état et conforme aux exigences de puissance d'entrée spécifiées dans le manuel.

Utiliser uniquement un cordon d'alimentation amovible avec des conducteurs dont la section est égale ou supérieure à 0,75 mm². Le cordon d'alimentation doit être approuvé par un organisme compétent tel que VDE, Semko ou SEV.

Sicherheitsvorschriften und Vorsichtsmaßnahmen (Deutsch)

Die untenstehenden allgemeinen Sicherheitsvorschriften sind bei allen Betriebsphasen dieses Instruments zu befolgen. Jede Mißachtung dieser Sicherheitsvorschriften oder sonstiger spezifischer Warnhinweise in dieser Betriebsanleitung stellt eine Zuwiderhandlung der für dieses Instrument geltenden Sicherheitsstandards dar und kann die an diesem Instrument vorgesehenen Schutzvorrichtungen unwirksam machen. MKS Instruments, Inc. haftet nicht für eine Mißachtung dieser Sicherheitsvorschriften seitens des Kunden.



Produkt erden!

Dieses Produkt ist mit einer Erdleitung und einem Schutzkontakt am Netzstecker versehen. Um der Gefahr eines elektrischen Schlages vorzubeugen, ist das Netzkabel an einer vorschriftsmäßig geerdeten Schutzkontaktsteckdose anzuschließen, bevor es an den Eingangs- bzw. Ausgangsklemmen des Produkts angeschlossen wird. Das Instrument kann nur sicher betrieben werden, wenn es über den Erdleiter des Netzkabels und einen Schutzkontakt geerdet wird.

Geht die Verbindung zum Schutzleiter verloren, besteht an sämtlichen zugänglichen Teilen aus stromleitendem Material die Gefahr eines elektrischen Schlages. Dies gilt auch für Knöpfe und andere Bedienelemente, die dem Anschein nach isoliert sind.



Keine Teile austauschen und keine Veränderungen vornehmen!

Bauen Sie in das Instrument keine Ersatzteile ein, und nehmen Sie keine eigenmächtigen Änderungen am Gerät vor! Schicken Sie das Instrument zu Wartungs- und Reparaturzwecken an einen MKS-Kalibrierungs- und -Kundendienst ein! Dadurch wird sichergestellt, daß alle Sicherheitseinrichtungen voll funktionsfähig bleiben.



Erdung und Verwendung geeigneter elektrischer Armaturen!

In diesem Instrument liegen gefährliche Spannungen an. Alle verwendeten elektrischen Armaturen und Kabel müssen dem angegebenen Typ entsprechen und sich in einwandfreiem Zustand befinden. Alle elektrischen Armaturen sind vorschriftsmäßig anzubringen und zu erden.



Hochspannungsgefahr!

Bei eingeschaltetem Steuerteil liegt im Kabel und im Sensor Hochspannung an.



Richtige Stromquelle verwenden!

Dieses Produkt ist für eine Stromquelle vorgesehen, bei der die zwischen den Leitern bzw. zwischen jedem der Leiter und dem Masseleiter anliegende Spannung den in dieser Betriebsanleitung angegebenen Wert nicht überschreitet.



Richtige Sicherung benutzen!

Es ist eine Sicherung zu verwenden, deren Typ, Nennspannung und Nennstromstärke den Angaben für dieses Produkt entsprechen.



Gerät nicht in explosiver Atmosphäre benutzen!

Um der Gefahr einer Explosion vorzubeugen, darf dieses Gerät nicht in der Nähe explosiver Stoffe eingesetzt werden, sofern es nicht ausdrücklich für diesen Zweck zertifiziert worden ist.



Wartung nur durch qualifizierte Fachleute!

Das Gehäuse des Instruments darf vom Bedienpersonal nicht geöffnet werden. Das Auswechseln von Bauteilen und das Vornehmen von internen Einstellungen ist nur von qualifizierten Fachleuten durchzuführen.



Richtiges Netzkabel verwenden!

Das verwendete Netzkabel muß sich in einwandfreiem Zustand befinden und den in der Betriebsanleitung enthaltenen Anschlußwerten entsprechen.

Das Netzkabel muß abnehmbar sein. Der Querschnitt der einzelnen Leiter darf nicht weniger als 0,75 mm² betragen. Das Netzkabel sollte einen Prüfvermerk einer zuständigen Prüfstelle tragen, z.B. VDE, Semko oder SEV.

Procedimientos y Precauciones de Seguridad (Español)

Las precauciones generales de seguridad que figuran a continuación deben observarse durante todas las fases de funcionamiento del presente instrumento. La no observancia de dichas precauciones, o de las advertencias específicas a las que se hace referencia en el manual, contraviene las normas de seguridad referentes al uso previsto del instrumento y podría impedir la protección que proporciona el instrumento. MKS Instruments, Inc., no asume responsabilidad alguna en caso de que el cliente haga caso omiso de estos requerimientos.



Puesta a tierra del instrumento.

Este instrumento está puesto a tierra por medio del conductor de tierra del cable eléctrico. Para evitar descargas eléctricas, enchufar el cable eléctrico en una toma debidamente instalada, antes de conectarlo a las terminales de entrada o salida del instrumento. Para garantizar el uso sin riesgos del instrumento resulta esencial que se encuentre puesto a tierra por medio del conductor de tierra del cable eléctrico.

Si se pierde la conexión protectora de puesta a tierra, todas las piezas conductoras a las que se tiene acceso (incluidos los botones y mandos que pudieran parecer estar aislados) podrían producir descargas eléctricas.



No utilizar piezas no originales ni modificar el instrumento.

No se debe instalar piezas que no sean originales ni modificar el instrumento sin autorización. Para garantizar que las prestaciones de seguridad se observen en todo momento, enviar el instrumento al Centro de servicio y calibración de MKS cuando sea necesaria su reparación y servicio de mantenimiento.



Usar los accesorios eléctricos adecuados.

Este instrumento funciona con voltajes peligrosos. Todos los accesorios y cables eléctricos deben ser del tipo especificado y mantenerse en buenas condiciones. Todos los accesorios eléctricos deben estar conectados y puestos a tierra del modo adecuado.



Peligro por alto voltaje.

Cuando el controlador está encendido, se registra alto voltaje en el cable y en el sensor.



Usar la fuente de alimentación eléctrica adecuada.

Este instrumento debe funcionar a partir de una fuente de alimentación eléctrica que no aplique más voltaje entre los conductores de suministro, o entre uno de los conductores de suministro y la puesta a tierra, que el que se especifica en el manual.



Usar el fusible adecuado.

Usar únicamente un fusible del tipo, clase de voltaje y de corriente adecuados, según lo que se especifica para el instrumento.



Evitar su uso en entornos explosivos.

Para evitar el riesgo de explosión, no usar este instrumento o en un entorno explosivo, a no ser que haya sido certificado para tal uso.



Reparaciones efectuadas únicamente por técnicos especializados.

Los operarios no deben retirar las cubiertas del instrumento. El cambio de piezas y los reajustes internos deben efectuarlos únicamente técnicos especializados.



Usar el cable eléctrico adecuado.

Usar únicamente un cable eléctrico que se encuentre en buenas condiciones y que cumpla los requisitos de alimentación de entrada indicados en el manual.

Usar únicamente un cable desmontable instalado con conductores que tengan un área de sección transversal equivalente o superior a 0,75mm². El cable eléctrico debe estar aprobado por una entidad autorizada como, por ejemplo, VDE, Semko o SEV.

Specifications*

Controller

Measuring Range**	1 x 10 ⁻¹¹ to 1.0 x 10 ⁺⁴ Torr 1 x 10 ⁻¹¹ to 1.3 x 10 ⁺⁴ mbar 1 x 10 ⁻⁹ to 1.3 x 10 ⁺⁶ Pa 1 x 10 ⁻⁸ to 1.0 x 10 ⁺⁷ microns
Operating Temperature Range	5° to 40°C (41° to 104°F)
Storage Temperature Range	-10° to 55°C (14° to 131°F)
Relative Humidity	80% maximum for temperatures less than 31°C, decreasing linearly to 50% maximum at 40°C
Altitude	2000 m (6561 ft) maximum
Insulation Coordination	Installation (Overvoltage) Category II, Pollution Degree 2
Power Requirement, Nominal	100, 120, 220, or 230/240 VAC 50/60 Hz
Mains Voltage	Fluctuations not to exceed ±10% of nominal
Power Consumption	35 W maximum
Fuse Rating, Size	T 0.63A for 100 VAC T 0.50A for 120 VAC T 0.315A for 220 VAC T 0.25A for 230/240 VAC, Ø 5 mm x 20 mm for all
Process Control Relay	5 nonvolatile, relay set points (one for each channel)
Relay Rating	SPDT, 2 A @ 30 V resistive
Relay Response	150 msec maximum

*Design and/or specifications subject to change without notice

**Measurement range depends upon sensor options selected

Analog Outputs	Buffered and Logarithmic (0.6 V/dec) outputs for each channel Two wide-range combination logarithmic outputs. Zout=100 ohms
Number of Channels	5
Front Panel Controls	Power on-off switch, 7-position rotary switch for function selection, 5-position rotary switch for sensor selection, 2 push-button switches for adjustments & control
Display	All active channels displayed at same time; LCD with 2 significant digits (1 leading) and 1½-digit signed exponent; 0.36"-high, 7-segment digits; ±60° viewing angle; status and error messages
Pressure Units	Torr, mbar, Pascal or microns
Update Rate	50 msec per sensor or 250 msec per full set of sensors in <i>Pressure</i> and <i>Leak Test</i> modes, 100 msec per sensor in all other modes
Leak Test	26-segment bar graph with a variable rate audio signal
Sensor Module Slots	3 (1 for a cold cathode only, 2 for any combination of cold cathode, Pirani, capacitance manometer, thermocouple, and convection Pirani sensor modules)
Sensor Modules	channels/module*
Cold Cathode	single
Pirani	dual or single
Convection Pirani	dual or single
Capacitance Manometer	dual or single
Thermocouple	dual or single

*Single channel module allows one sensor to have two independent adjustable set point relays in Slots A and B.

Computer Interface (Optional)	<i>Serial</i> – RS-232 and RS-485 2400, 4800, 9600, 19200 bit rate selectable
Electronic Casing	Aluminum
Dimensions (W x D x H)	9½" x 12¼" x 3½" (241 mm x 311 mm x 88 mm)
Size	½ rack, 2U high
Typical Weight	8.0 lb (3.6 kg)
CE Certification	EMC Directive 89/336/EEC Low Voltage Directive 73/23/EEC

Sensors

Sensor Type

<i>CC</i>	Series 421 inverted magnetron Series 423 I-MAG®
<i>Pirani</i>	Series 315 Pirani Series 345 Pirani
<i>Convection Pirani (CEP)</i>	Series 317 Convection Pirani
<i>CM</i>	MKS Baratron® 622A, 626A, or 722A Capacitance Manometer; ±15 V at 35 mA externally-powered; unheated; 0 to 10 V range transducer, 10 V corresponds to either 1, 10, 100, 1 K, or 10K Torr full-scale head
<i>TC</i>	Teledyne-Hastings DV-6M

Pressure Range

<i>CC</i>	1×10^{-11} to 1×10^{-2} Torr 1×10^{-11} to 1×10^{-2} mbar 1×10^{-9} to $1 \times 10^{+0}$ Pa 1×10^{-8} to $1 \times 10^{+1}$ microns
<i>Pirani</i>	5×10^{-4} to $4 \times 10^{+2}$ Torr 7×10^{-4} to $5 \times 10^{+2}$ mbar 7×10^{-2} to $5 \times 10^{+4}$ Pa 5×10^{-1} to $4 \times 10^{+5}$ microns
<i>Convection Pirani</i>	1.0×10^{-3} to $1.0 \times 10^{+3}$ Torr 1.3×10^{-3} to $1.3 \times 10^{+3}$ mbar 1.3×10^{-1} to $1.3 \times 10^{+5}$ Pa $1.0 \times 10^{+0}$ to $1.0 \times 10^{+6}$ microns
<i>CM</i>	Three decades below full scale of head, (e.g., 10 Torr head is 1.0×10^{-2} to $1.0 \times 10^{+1}$ Torr)
<i>TC</i>	1.0×10^{-3} to $1.0 \times 10^{+0}$ Torr 1.3×10^{-3} to $1.3 \times 10^{+0}$ mbar 1.3×10^{-1} to $1.3 \times 10^{+2}$ Pa $1.0 \times 10^{+0}$ to $1.0 \times 10^{+3}$ microns

Relay Set Point Range

<i>CC</i>	2.0×10^{-10} to 9.5×10^{-3} Torr 2.7×10^{-10} to 1.2×10^{-2} mbar 2.7×10^{-8} to $1.2 \times 10^{+0}$ Pa 2.0×10^{-7} to $9.5 \times 10^{+0}$ microns
<i>Pirani</i>	2.0×10^{-3} to $9.5 \times 10^{+1}$ Torr 2.7×10^{-3} to $1.2 \times 10^{+2}$ mbar 2.7×10^{-1} to $1.2 \times 10^{+4}$ Pa $2.0 \times 10^{+0}$ to $9.5 \times 10^{+4}$ microns
<i>CEP</i>	2.0×10^{-3} to $9.5 \times 10^{+2}$ Torr 2.7×10^{-3} to $1.2 \times 10^{+3}$ mbar 2.7×10^{-1} to $1.2 \times 10^{+5}$ Pa $2.0 \times 10^{+0}$ to $9.5 \times 10^{+5}$ microns
<i>CM</i>	1% to 95% of the measurement range of the head (e.g. 1 Torr head is 1.0×10^{-2} to 9.5×10^{-1} Torr, $1.3 \times 10^{+0}$ to $1.2 \times 10^{+2}$ Pa, etc.)
<i>TC</i>	2.0×10^{-3} to 9.5×10^{-1} Torr 2.7×10^{-3} to $1.2 \times 10^{+0}$ mbar 2.7×10^{-1} to $1.2 \times 10^{+2}$ Pa $2.0 \times 10^{+0}$ to $9.5 \times 10^{+2}$ microns

Response Time

<i>CC</i>	40 msec
<i>Pirani, CEP</i>	150 msec
<i>CM</i>	50 msec
<i>TC</i>	150 msec

Resolution

<i>CC</i>	2 significant digits between 10^{-10} and 10^{-3} Torr, 1 significant digit outside that range
<i>Pirani</i>	2 significant digits between 10^{-3} and 99 Torr, 1 significant digit outside that range. Display will indicate $1 \times 10^{+2}$, $2 \times 10^{+2}$, $3 \times 10^{+2}$, $4 \times 10^{+2}$ and AA in upper decade.
<i>CEP, CM, TC</i>	2 significant digits

Repeatability

<i>CC, Pirani, CEP, TC</i>	5% of indicated pressure at constant temperature
<i>CM</i>	2% of indicated pressure at constant temperature

Calibration Gas

<i>CC, Pirani, CEP, TC</i>	Air/nitrogen
<i>CM</i>	Any (gas independent)

Installation Orientation

<i>CC, TC, CM, Pirani</i>	Any (port down suggested)
<i>CEP</i>	Body horizontal only

Materials Exposed to Vacuum

<i>CC</i>	Series 421 – SS 304, Al 6061, silver-copper brazing alloy, alumina ceramic, Elgiloy®, OFHC® copper Series 423 – SS 302, SS 304, glass, Al, Inconel X-750®, alumina ceramic
<i>Pirani</i>	300 series stainless, platinum, alumina ceramic, silver brazing alloy, nickel 200
<i>CEP</i>	300 series stainless, nickel, glass, platinum
<i>CM</i>	Inconel®
<i>TC</i>	Nickel-plated steel, noble metal alloy, glass

Internal Volume *

<i>CC</i>	Series 421 - 1.8 in. ³ (30 cm ³) Series 423 - 0.9 in. ³ (15 cm ³)
<i>Pirani</i>	0.5 in. ³ (8 cm ³)
<i>CEP</i>	2.0 in. ³ (33 cm ³)
<i>CM</i>	Type 122 - 0.43 in. ³ (7 cm ³) Type 622/626 - 0.38 in. ³ (6.3 cm ³) Type 722 - 0.07 in. ³ (1.2cm ³)

*Volume will vary with the type of vacuum connection selected

Operating Temperature Range

<i>CC</i>	Series 421 - 0° to 70°C (32° to 158°F) Special available that operates up to 200°C. Series 423 - 0° to 70°C (32° to 158°F)
<i>Pirani</i>	0° to 50°C (32° to 122°F)
<i>CEP</i>	10° to 50°C (50° to 122°F)
<i>CM</i>	0° to 50°C (32° to 122°F)
<i>TC</i>	0° to 40°C (32° to 104°F)

Maximum Bakeout Temperature (Without Controller or Cables)

<i>CC</i>	Series 421 – 250°C (482°F) when backshell subassembly removed, 125°C (257°F) otherwise ; Series 423 – 400°C (752°F) CF flange version only with magnet removed
<i>Pirani</i>	50°C (122°F)
<i>CEP</i>	150°C (302°F) 100°C (212°F) RF shielded
<i>CM</i>	N/A
<i>TC</i>	60°C (140°F)

Diameter

<i>CC</i>	Series 421 – 2.2 in. (56 mm) Series 423 – 2.6 in. (66 mm)
<i>Pirani</i>	1.3 in. (34 mm)
<i>CEP</i>	1.6 in. (41 mm)
<i>CM</i>	Type 122 - 3.0 in. (76 mm) Types 622 and 626 - 2.6 in. (66 mm) Type 722- 1.5 in. (38 mm)
<i>TC</i>	1.3 in. (34 mm)

Length*

<i>CC</i>	Series 421 – 6.3 in. (160 mm) Series 423 – 3.4 in. (86 mm)
<i>Pirani</i>	4.4 in. (112 mm)
<i>CEP</i>	4.4 in. (112 mm)
<i>CM</i>	Type 122 and 622 - 4.9 in. (124 mm) Type 626 - 4.8 in. (121 mm) Type 722 - 3.9 in. (99 mm)
<i>TC</i>	1.3 in. (34 mm)

Typical Weight (with 2¾" CF Flange)

<i>CC</i>	421 - 2.4 lb (1.1 kg) 423 - 1.8 lb (0.8 kg)
<i>Pirani</i>	0.5 lb (0.2 kg)
<i>CEP (w/ KF Flange)</i>	0.5 lb (0.2 kg)

Vacuum Connection

<i>CC</i>	KF 25 KF 40 2¾" CF 8 VCR® -F (½") 1" tubing
<i>Pirani, CEP</i>	KF 16 KF 25 ⅛" NPT-M with ½" compression seal 8 VCR® -F 4 VCR® -F 1⅓" CF (non-rotatable) 2¾" CF (non-rotatable)
<i>CM</i>	KF 16 8 VCR® -F (½") 8 VCO® -F (½") 1⅓" CF (non-rotatable) ½" tube
<i>TC</i>	⅛" NPT-M

*Length will vary with the type of vacuum connection selected. Refer to product brochure for dimensions prior to installation.

Feature and Control Locations

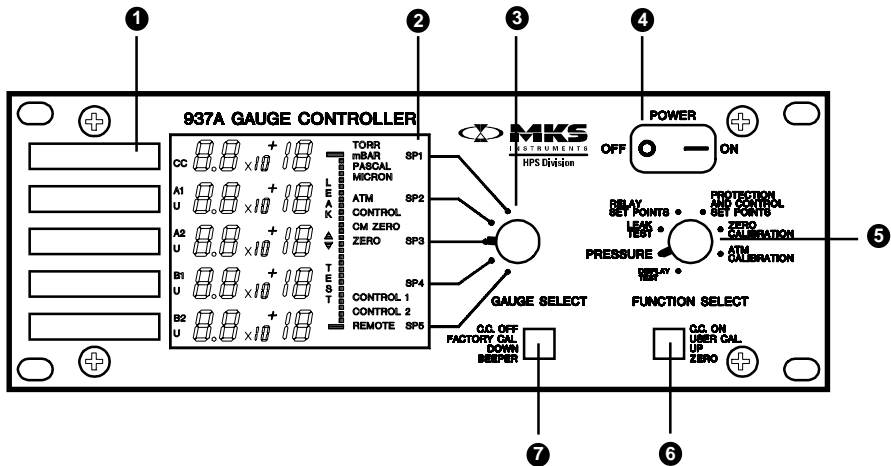

Front Panel

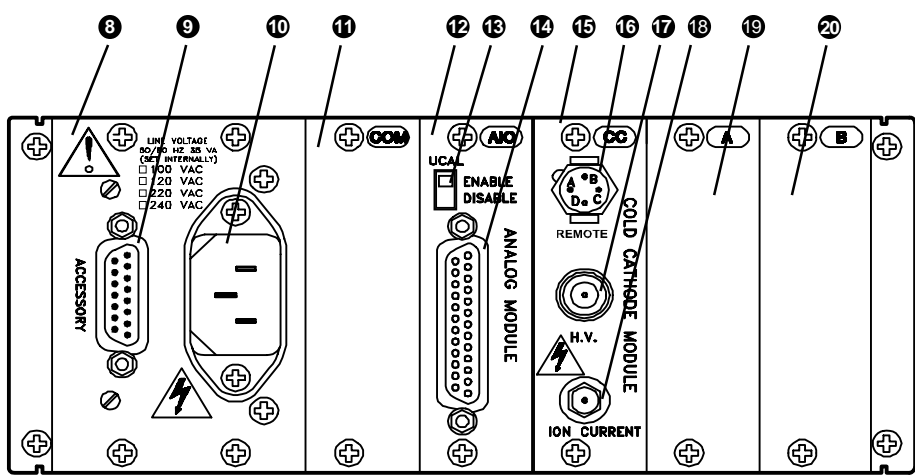

Rear Panel

- ① Display Label
- ② Liquid Crystal Display
- ③ *Gauge Select* Rotary Switch
- ④ Power On-Off Switch
- ⑤ *Function Select* Rotary Switch
- ⑥ *C.C. On/User Cal/Up/Zero* Push-button
- ⑦ *C.C. Off/Factory Cal/Down/Beeper* Push-button
- ⑧ Power Supply Module
- ⑨ Male, 15-pin "D" *Accessory* Connector
- ⑩ AC Power Inlet, IEC 320
- ⑪ Slot for optional Communications Module
- ⑫ Analog Module
- ⑬ *UCAL Enable/Disable* Switch
- ⑭ Female, 25-pin "D" Analog Output Connector
- ⑮ Slot CC for Cold Cathode Sensor Module
- ⑯ High Voltage *Remote* Enable Connector
- ⑰ High Voltage SHV Connector
- ⑱ Ion Current SMA Connector
- ⑲ Slot A for Either Single or Dual Sensor Module
- ⑳ Slot B for Either Single or Dual Sensor Module

Slot COM

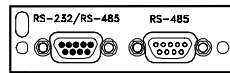

Slot CC

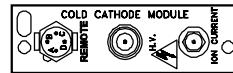

Slot A or B

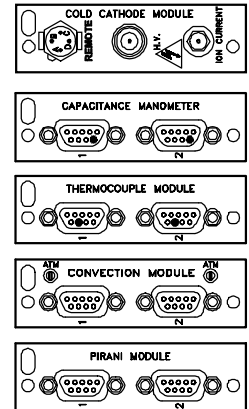

Typical Applications for the Series 937A

- ◆◆ **Measurement** of high vacuum chamber pressures
- ◆◆ **Control** of high vacuum systems and process sequencing using relay set points
- ◆◆ **Sensing abnormal pressure** and taking appropriate security measures using relay set points
- ◆◆ **Controlling system pressure** using the analog output as input to an automatic pressure controller
- ◆◆ **Starting or stopping system processes** with relay set points
- ◆◆ **Measuring** pressures of backfilled gases
- ◆◆ **Leak testing** your vacuum system

HPS™ Products Series 937A Multi-Sensor High Vacuum System

THE HPS™ PRODUCTS SERIES 937A Multi-Sensor High Vacuum System uses the technologies of the cold cathode, standard Pirani, convection Pirani, and thermocouple sensors and the capacitance manometer together to measure pressures from as high as 10,000 Torr down to ultra high vacuum. The System operates as many as five sensors simultaneously. The Series 937A Controller is configured to your specifications — you choose the type and number of sensors, the line voltage, frequency, units of measure, and communications interface.

A large, easy-to-read liquid crystal display (LCD) provides simultaneous pressure readings for all sensors. If a sensor is turned off, not connected properly, or used out of range, a relevant message replaces its pressure reading. The Controller's *Function Select* rotary switch and push-button labels are color-coded to simplify use. Near each sensor's readout, white space is provided so that you may write in sensor information specific to your system.

The Controller can be set up with a cold cathode sensor module and two more sensor modules to operate either capacitance manometers or cold

cathode, Pirani, Convection Pirani, or thermocouple sensors.

After setup, you can confirm your settings with the Controller's setup review feature.

A display message will let you know if the Controller has detected a broken sensor wire or improper connection for the Pirani, thermocouple, and Convection Pirani sensors.

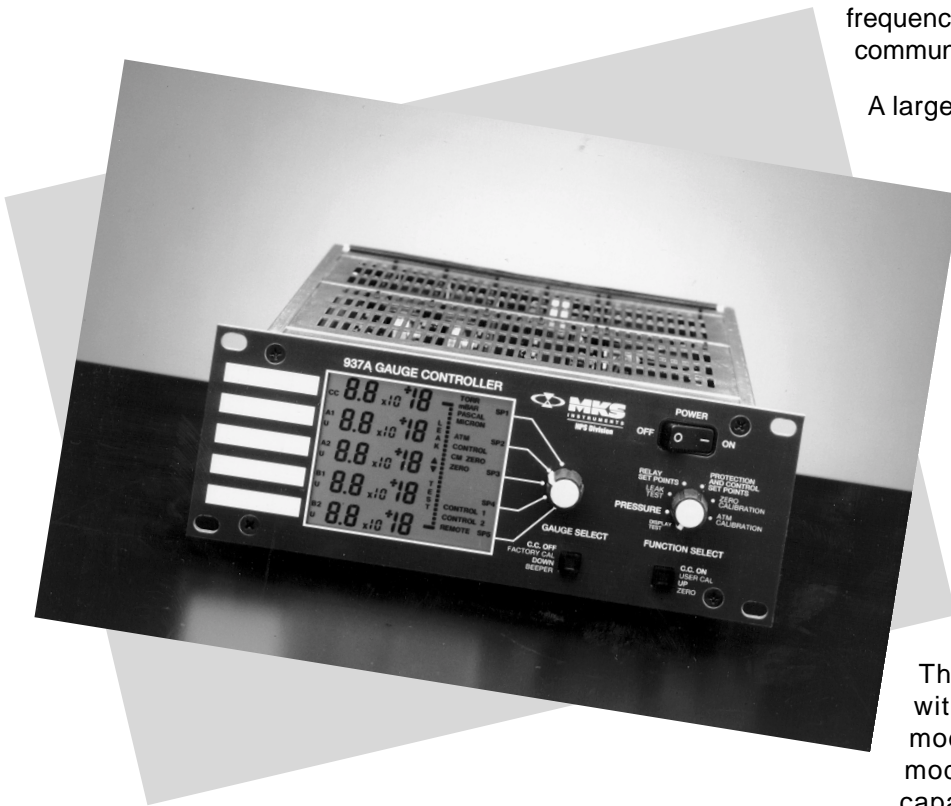

Set Points

Control your system with five independently adjustable relay set points. They may be set or disabled from either the front panel or the optional communications module. The set points are nonvolatile, remaining unchanged after powering down or during a power failure.

The Controller also includes additional protection and control set points to turn a cold cathode sensor off at higher pressures, extending the operating time before maintenance is required.

Leak Test

The *Leak Test* mode consists of a bar graph and variable rate beeper to locate system leaks. This mode operates with any sensor except a capacitance manometer.

Analog Output Signals

Analog output signals, which can be sent to a data acquisition system, are available for each sensor from the Analog connector on the Analog Module. These include buffered, logarithmic, and combination logarithmic output.

Buffered and logarithmic analog outputs are available simultaneously from all sensors.

A buffered analog signal responds immediately to sensor signal changes.

Logarithmic pressure output ranges from 0 to 10 V and is scaled to 0.6 V per decade of pressure change, regardless of sensor type or channel. However, these outputs are updated each 50 to 250 ms depending on the number of sensors in the controller.

Combination logarithmic output is a combined reading of pressures from a cold cathode sensor and its control sensor (a Pirani or other medium pressure sensor). It provides a continuous analog output representing a wide range of pressure, from 1.0×10^{-11} to as high as 1000 Torr, from a single output.

Computer Interface

Direct computer communication is available to control front panel functions or read pressure and other information remotely. A Controller slot for an optional module supports RS-232 and RS-485.

Setting Up the Series 937A Controller

This section covers switch and jumper settings on the various Controller modules — sensor, analog, power supply, and optional communications modules. Controller power supply and mounting is also covered. For information on connecting sensors and their cables to the Series 937A Controller, see **Appendix A**.

To change the factory Controller configuration, remove and adjust the appropriate module following the steps below.

Removing a Module



Lethal voltages are present in the Controller when powered. Disconnect the power cable before disassembly.



All necessary ESD handling precautions should be followed while installing, configuring or adjusting the instrument or any modules.

To remove a module for modification,

- 1 Using a #1 Phillips screwdriver, remove the two screws on the top and bottom of the rear panel of the module.
- 2 Use a small, flat-blade screwdriver to gently pry the module away from the rear panel frame until it slides freely.
- 3 **Carefully** slide the module out.
- 4 Place the module on a static protected work bench.

Configuring a Module

Sensor Modules

The Series 937A System has three module slots, labeled CC, A, and B, to accommodate a number of sensor configurations.

Only a cold cathode sensor module can be used in Slot CC. Slots A and B accommodate any of the Series 937A System sensor modules, either single-channel or dual-channel. Slots A and B have two channels, designated A1/B1 and A2/B2. If a single channel module is used, the active channel will be A1 or B1. For single channel modules, connect the sensor to the upper connector (labeled 1) only.

Five set point relays are available – one for slot CC and two each for slots A and B. If a single-channel module is used in Slot A or B, both relays are controlled by that channel and may be independently adjusted to different set point pressures.

When using more than one sensor type, verify that the correct sensor and cable are connected to each module.

The figure to the right shows possible module arrangements.

Cold Cathode

A cold cathode sensor module can be installed in any Slot – CC, A, or B. The cold cathode sensor module is a single-channel module.

Slot CC will operate *only* with a cold cathode sensor module installed. If any other sensor module or no sensor module is installed in Slot CC, the Series 937A Controller will simply ignore it.

A Cold Cathode Sensor Module must be plugged into Slot CC if capacitance manometer auto-zero is to be used (see **Capacitance Manometer Auto-Zero Feature**, page 55).

Three DIP switches on the Analog Module are set to control the operation of the cold cathode sensor (see **Analog Module**, page 31).

Setting two jumpers on the cold cathode sensor module can make it compatible with either the Series 937A Controller or older Series 937 or Series 929 controllers. For use in the Series 937A Controller,

- 1 Set the *uP/Com* (microprocessor/communications module) jumper to *uP*.
- 2 Set the *SW/PS* (software/direct power supply) jumper to *SW*.

An older cold cathode sensor module, (rear enable connector labeled *H. V. Enable*) has either only the first of these jumpers or neither. To use older modules in a Series 937A Controller or new modules in a Series 937 or 929 controller, contact HPS™ Products Applications Engineering at MKS Vacuum Products Group to request the application note on *Configuration of Cold Cathode Modules for 929/A/937/A Controllers*.

Pirani

A Pirani sensor module can be installed in Slots A, B, or both. Either a single-channel or a dual-channel module is available.

The Pirani module has no switches or jumpers to set.

Though the Pirani and Convection Pirani sensor modules are designed to prevent damage to themselves or their sensors if sensors were accidentally interchanged, an inaccurate pressure would be indicated if they were.

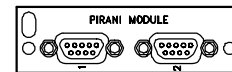
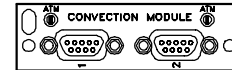
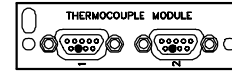
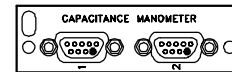
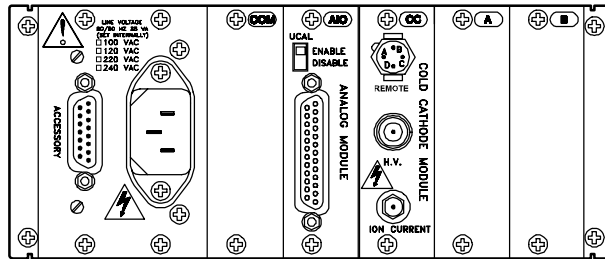

Sensor module options for slots A and B

Jumper

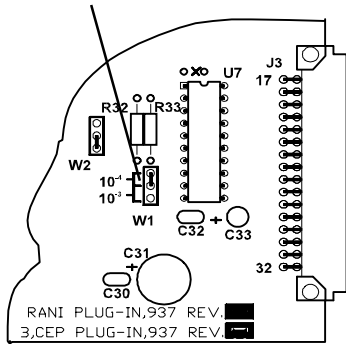

Convection Pirani sensor jumper

Convection Pirani

A Convection Pirani sensor module can be installed in Slots A, B, or both. Either a single-channel or a dual-channel module is available.

A 3-pin header *W1* with a jumper is near the end of the module opposite the rear panel of the Controller. The jumper should always be in the 10^{-4} position as shown to the right.

Though the Pirani and Convection Pirani sensor modules are designed to prevent damage to themselves or their sensors if the sensors were accidentally interchanged, an inaccurate pressure would be indicated if they were.

Capacitance Manometer

A capacitance manometer module can be installed in slots A, B, or both. Either a single-channel or a dual-channel module is available.

The figure to the left shows a cutout of the capacitance manometer module. The table on the left side of the DIP switches shows appropriate head settings. Each channel has one set of four switches.

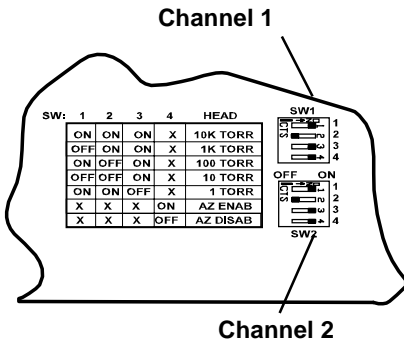

CM DIP switches shown with 100Torr head and Auto-Zero (AZ) on

Set the module to the capacitance manometer's full scale value with switches 1, 2, and 3. It is important to set these switches correctly for the head in use, since the controller has no way to externally verify the setting matches the type of head used.



"Head" refers to the full scale pressure reading of the selected sensor. This pressure gives a 10 V output. It is always 1.0×10^N Torr. Heads calibrated so that 10V corresponds to some other pressure or units give incorrect readings.

In other words, the capacitance manometer must provide a 0-10V output with the full scale range specified in Torr, even if the Series 937A Controller will be set to display in some other units.

Two setting combinations of switches 1, 2, and 3 (not shown in the figure) are not valid. When the Controller is turned on, **S E T U P E R R O R** appears on the display.

Use switch 4 to enable or disable capacitance manometer auto-zero (see **Capacitance Manometer Auto-Zero Feature**, p. 55).

Both channels are factory preset to 1 Torr head with auto-zero off.

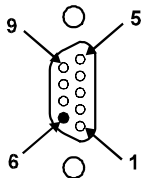

Keyed "D" connector for capacitance manometer module

The figure to the right shows the capacitance manometer module's "D" connector. A key is placed in contact #6. This key prevents connection of a Pirani, thermocouple, or convection sensor cable to a capacitance manometer module. (The reverse is possible however. It is possible to plug a capacitance manometer cable into a Pirani or Convection Pirani sensor module, but this should not damage either the sensor or the module.)

Thermocouple

A thermocouple module can be installed in Slots A, B, or both. Either a single-channel or a dual-channel module is available.

The figure to the right shows the thermocouple module's "D" connector. A key is placed in contact #8. This key prevents connection of a Pirani, capacitance manometer, or Convection Pirani sensor cable to a thermocouple module. (The reverse is possible however. It is possible to plug a thermocouple cable into a Pirani or Convection Pirani sensor module, but this should not damage either the sensor or the module.)

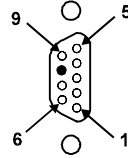

Keyed "D" connector for thermocouple sensor module

Analog Module

Five Controller features may be individually set on this module. Individual settings are shown on the inside column.

<i>S 1</i>		<i>S 2</i>	Pressure Units – Switches 1 and 2
<i>Torr</i>	Off	Off	All pressure values will display in the unit selected. If set points are set prior to a pressure unit change, they must be reset. Capacitance manometer heads must provide a 0-10V output with full scale range specified in Torr. Factory preset units: As requested
<i>mbar</i>	On	Off	
<i>Pascal</i>	Off	On	
<i>microns</i>	On	On	
<i>For Slot CC</i>			Control/Combination Sensor Channels– Switches 3 and 4 A control sensor switches a cold cathode sensor on and off at a specific pressure (see Using Protection and Control Setpoints , page 60). When the ranges of these two sensors overlap, the outputs from the two sensors are also used to generate a combination output (see page 66).
<i>B1</i>	Off	<i>S 3</i>	
<i>B2</i>	On		Control/Combination Sensor Channels– Switches 3 and 4 Cold cathode sensors in Slots CC and A may have control sensors. A control sensor can only be located in channel B1 or B2. Suitable control sensors are thermocouple, Pirani, convection Pirani, and 1, 10 and 100 Torr capacitance manometers. Note the ranges of the 10 and 100 Torr capacitance manometer head do not overlap the cold cathode sensor range, so they can not be used to generate a combination output. Factory preset control sensor:
<i>For Slot A</i>			
<i>B1</i>	Off	<i>S 4</i>	for slot CC
<i>B2</i>	On		for slot A

S 5	Line Frequency – Switch 5
60 Hz Off 50 Hz On	Set this switch to the line frequency in use to minimize noise pickup. This switch does not affect the power supply. Factory preset line frequency: As requested
S 6	Cold Cathode Sensor Delay – Switch 6
3 sec Off 30 sec On	When cold cathode sensors are turned on at high vacuum, the discharge current does not start immediately. This delay prevents activation of the cold cathode set point relays and updating the processed outputs until the delay has expired. After the selected delay, the pressure may be reported as LO if the cold cathode sensor has not started. Factory preset cold cathode sensor delay: 3 sec
S 7	Configuration-Switch 7
Off	This switch should only be on for conditions described in the application note on <i>Configuration of Cold Cathode Modules for 929/A/937/A Controllers</i> .

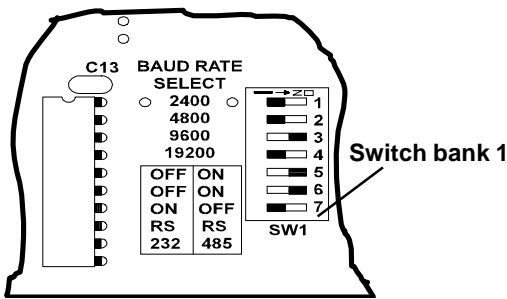

Serial rate and protocol selection, switches are set for bit rate 9600, RS-485

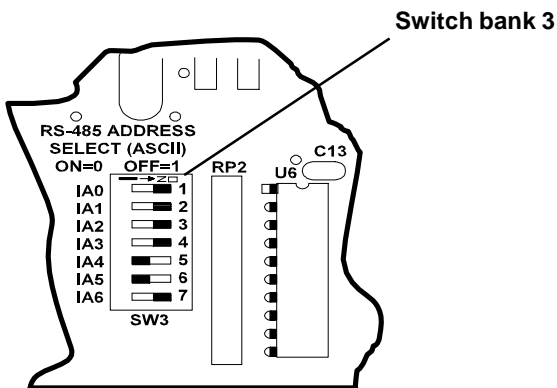

RS-485 address character selection, switches are set for 30H, ASCII 0

UCAL Enable/Disable

The rear panel *UCAL Enable/Disable* switch locks out use of *Atm* and *Zero Calibration* modes for all sensors except capacitance manometers.

Factory preset *UCAL Enable/Disable*: Disabled

RS-232/RS-485 Communications Module (Optional)

The character format is 8 data bits (MSB always 0), 1 stop bit, and either even or no parity.

Select a serial bit rate and protocol from the DIP switch bank *SW1* on the RS-232/RS-485 module, as shown here.

- 1 Select RS-232 or RS-485 electrical interface with switches 6 and 7.
- 2 Select the logical protocol with switch 5 (multidrop, with attention and address characters, or simple).
- 3 Select serial bit rate and parity with switches 1- 4.

With RS-485 communications, multiple controllers can be connected to a host computer on a common cable. The multidrop protocol must be used. A unique address is needed for each device. *SW3* should be set to a binary code representing the controller's address. The "\$" (00100100B or 24H), or "attention" character, always precedes the address and may not be used for any other purpose. Recommended ASCII characters for addresses are **0** through **9** (30H-39H), **A** through **Z** (41H-5AH), and **a** through **z** (61H-7AH), although any value from **0** to **127** (7FH) except "\$" may be used.

RS-485 communications at high speed and over long wires may require both ends of the cable to be terminated with its characteristic impedance. Holes marked *R1* on the module are for a termination resistor if needed. For twisted pair wire, 120 ohms should be used.



This resistor should only be used on the module at the end of the transmission line.

If a parity error occurs in a command sent to the Controller, it will discard all characters received and wait for another command. No error message or other response is sent back to the host computer. Use of parity is recommended.

See the section on **Parity** in the *RS-232/RS-485 Communications Module User's Manual* for more information.

Since the simple protocol does not require attention and address characters, the remaining portion of a faulty command may be misinterpreted. Therefore, with a parity error, the Controller may respond differently from what's expected.

To avoid this, the more robust multidrop protocol may be used with a RS-232 interface.

- 1 Set module switches 5 and 7 to On.
- 2 Set 6 to Off.
- 3 Use attention and address characters with RS-232 wiring and signal levels.

Bit Rate and Parity Selection			
Bit Rate	Parity	SWI Setting ¹	
		Switch	Position
2400	Even	1	On
		2,3,4	Off
	None	1	Off
		2,3,4	On
4800	Even	2	On
		1,3,4	Off
	None	2	Off
		1,3,4	On
9600	Even	3	On
		1,2,4	Off
	None	3	Off
		1,2,4	On
19,200	Even	4	On
		1,2,3	Off
	None	4	Off
		1,2,3	On

1. Note: other combinations will default to 9600bps parity

ELECTRICAL INTERFACE AND LOGICAL PROTOCOL

CONNECTION TYPE	SWI SETTING	
	SWITCH	POSITION
Normal RS-232		
Simple Protocol	5	Off
Rs-232 Interface	6	Off
	7	On
Normal RS-485		
Multidrop Protocol	5	On
RS-485 Interface	6	On
	7	Off
RS-232 Interface with Multidrop Protocol	5	On
	6	Off
	7	On

A 9-pin "D" connector is used for RS-232 and RS-485 serial interfaces. Three pins are used for the RS-232 interface using the standard PC-AT connections for a DTE (data terminal equipment) device. Two more pins are used for the RS-485 interface. A second pass-through connector for RS-485 facilitates connection of multiple devices on the same bus.

Refer to the *RS-232/RS-485 Communications Module User's Manual* for more information on using this module.

Power Supply Module



Lethal voltages are present in the Controller when powered. Disconnect the power cable before disassembly.

Line Voltage	Fuse Type
100 VAC 120 VAC 220 VAC 230/240 VAC	T 0.63A T 0.5A T 0.315A T 0.25A

The figure below shows power supply module jumpers for Controller line voltage selection. Before shipment, they are set to the line voltage requested. If you need to change the line voltage, set the jumpers for the new voltage, and install fuses correspondingly.

The fuse holders are located adjacent to the voltage selection jumpers. Any changes should be made by qualified service personnel. The correct fuses (time-lag, Ø 5 mm x 20 mm) are shown at right.

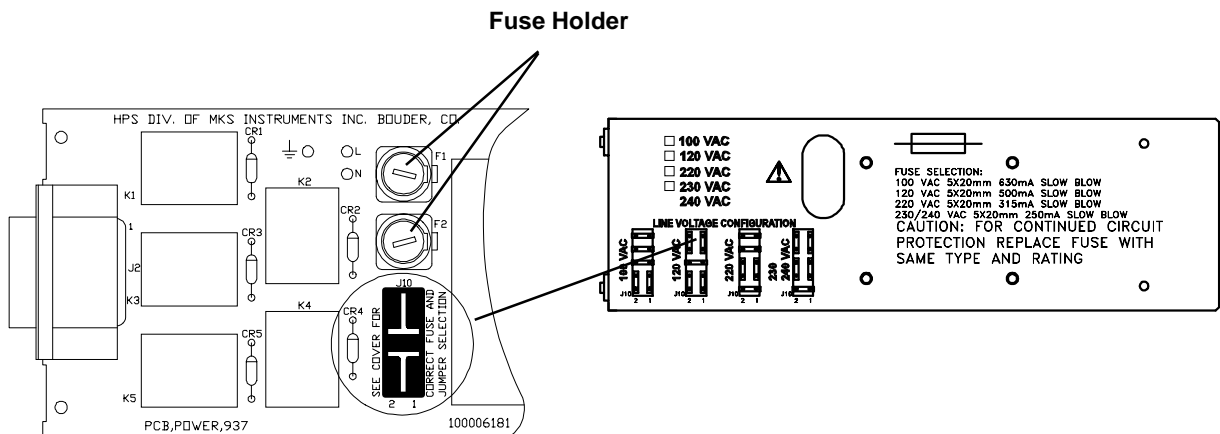

Power supply voltage selection jumper

Installing a Module

It is very important to place the correct module in the correct slot.

- 1 Align the module to fit and slide freely in the card guides, with the internal 32-pin DIN connector end first.
- 2 Gently slide the module forward.
- 3 Carefully push on the rear panel to lock the internal connectors together, making sure that the screw holes on the rear panel align with the threaded inserts.
- 4 Replace and tighten the two screws with a Phillips screwdriver.

A change of pressure units, module type, or capacitance manometer head range may invalidate user calibration and setpoint values. If the set point value is within the acceptable range, it will remain the same numeric value. If it is not within the acceptable range, then the setpoint will be disabled and reset to 0.0 . If the type of sensor module or capacitance manometer head range is changed, any calibration values previously set will be returned to the factory calibration value. Reset values if necessary.



When removing one type of sensor module and installing another type, or when changing the pressure units (Torr, micron, etc.), set point values are not automatically converted.

Panel Labels

Five white labels are located on the far left of the front panel for user notations, such as type and location of sensors, set point values, calibration status, or other pertinent information. Write with a standard pencil on the labels or apply preprinted adhesive labels. Remove pencil marks with isopropyl alcohol, glass cleaner, or a pencil eraser.



Do not use acetone to clean the front panel.

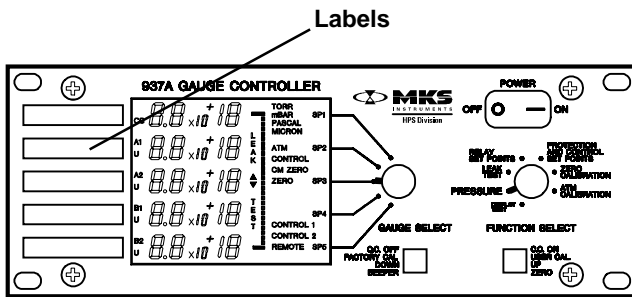

Mounting the Controller

The 937A was designed for either rack mounting or for benchtop use. Regardless of the method you choose, to assure adequate ventilation to the Controller, leave at least 1 inch open above the perforated panels. Side clearance is not required.

To accommodate connectors and cables, leave open about 3 inches of clearance behind the rear panel.

For benchtop use, adhesive backed rubber pads are provided. Remove the adhesive backing from each pad and apply one to each corner of the bottom surface.

Optional mounting hardware is available for mounting the Series 937A controller in a 19 inch rack.

Mounting the Series 937A controller into a 19" rack (HPS Part 100005651)

- 1 Attach the faceplate (3.5"x5.5") to each side of the 937A front panel using the four 10-32 screws provided. Secure the screws with the nuts included in the kit.
- 2 Secure this assembly to the rack using the ¼" screws provided. It may be necessary to loosen the 10-32 screws securing the faceplates in order to align the holes with the mounting holes on the rack.

Mounting 937 with another ½ rack instrument. (HPS Part 100005651)

- 1 Attach the ½ rack instrument to the Series 937A controller using the small splicing plate and the four 10-32 screws provided. The splicing plate is used to connect the front panel of each instrument together.
- 2 Secure this assembly to the rack using the ¼" screws provided. It may be necessary to loosen the 10-32 screws securing the splicing plate in order to align the holes with the mounting holes on the rack.



All the items in the kit may not be necessary depending on the mounting configuration.

Please contact HPS™ Products Applications Engineering for solutions to other mounting configurations.

AC Power Cord

The Series 937A Controller includes a standard 120 VAC, 50/60 Hz power cord with a female IEC 320 connector. If the power source is different, use only a harmonized, detachable cord set with conductors having a cross-sectional area equal to or greater than 0.75 mm². The power cord should be approved by a qualified agency such as VDE, Semko, or SEV.



Properly ground the Controller and vacuum system.

The Series 937A Controller is grounded through the ground conductor of the power cord. If the protective ground connection is lost, all accessible conductive parts may pose a risk of electrical shock. Plug the cord into a properly grounded outlet only.

Do not exceed manufacturer's specifications when applying voltage. Electrical shock may result.



Before turning on the Series 937A Controller, all configuration switches must be correctly set, all modules must be securely tightened, and all sensors must be connected.

If error messages appear on the display after switching on the Series 937A Controller, see the **Error Messages** section on page 64.

Operating the Series 937A Controller

 Please note, the characters on the Controller digital display vary slightly from those shown in this manual (e.g., P I R is actually P_{IR} and T C is actually t_c).

 If REMOTE indicator is displayed, operation from the Front Panel has been disabled. Please refer to "Front Panel Control Lock" on page 45.

Power

When not using the Series 937A Controller, turn the *Power* switch to *Off*.
When turning the Controller off, allow it to remain off for at least 5 sec before turning it back on.

If after turning the power on, the Controller makes a periodic beeping sound or an unusual message is displayed, see **Error Messages**, page 64.

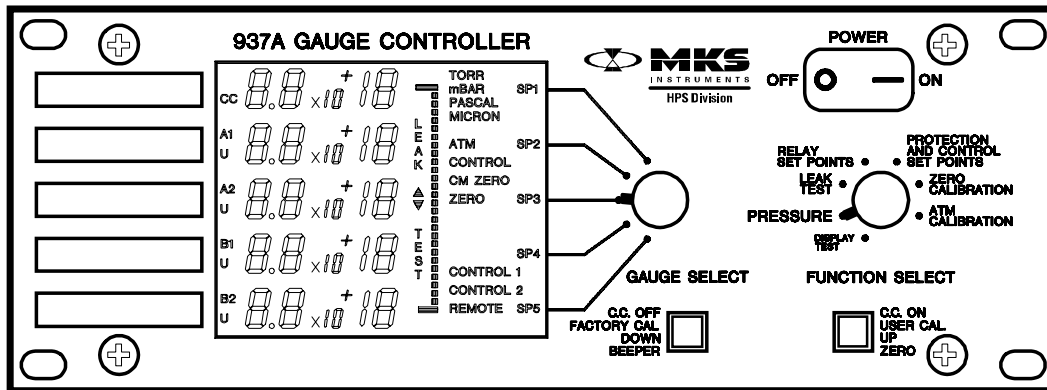

Display

Refer to this figure for the following display indicator information.

8.8 X 10⁺¹⁸

Pressure Reading - indicates current pressure when in *Pressure* mode. It indicates other values or messages in other modes. All operating channels are displayed at the same time.

CC, A1, A2, B1, or B2

Channel - indicates a sensor module is inserted in this slot. A2 and B2 only display if a dual sensor module is installed. These indicators are displayed in any *Function Select* mode.

U

User Zero (Vacuum) or Atmospheric Calibration - indicates the factory default calibration setting for zero, atmosphere, or both have been overridden. It is displayed in any *Function Select* mode and is only displayed beneath channel indicators for Slots A and B.

SP1, SP2, SP3, SP4, or SP5

Set Point Relay Status - indicates the corresponding set point relay is active (i.e., pressure is below the set point value).

TORR, mBAR, PASCAL, or MICRON

Unit of Measure - indicates selected unit of measure for pressure and is displayed in any *Function Select* mode.

ATM

Atmospheric Calibration- indicates *Function Select* switch is in the *ATM Calibration* mode.

CONTROL

Cold Cathode Sensor Control - indicates a control sensor relationship exists between the two channels displayed.

CM ZERO

Automatic Zeroing - indicates auto zeroing is taking place for one or more capacitance manometer channels.

ZERO

Zero (Vacuum) Calibration- indicates *Function Select* switch is in the *Zero Calibration* mode.

CONTROL 1 (Slot CC) or CONTROL 2 (Slot A) with C T L

Control Sensor Status - indicates that the control sensor's pressure is above the control set point and has turned the cold cathode sensor's high voltage off.

REMOTE

Controller Functions Disabled Locally - indicates all functions on the Controller's front panel are disabled and are accessible only from the optional communications interface.

In *Zero* or *ATM Calibration* mode, with UCAL DISAB, indicates calibration is locked out by a command to the communications interface.

LEAK  **TEST** (displayed vertically)

Leak Test Status - indicates *Function Select* switch is in *Leak Test* mode.

 (displayed vertically)

Bar Graph - In *Zero Calibration* mode, shows pressure deviation from initial or reset zero. In *Leak Test* mode, indicates change due to a probe gas. Line segments above or below the center of the bar graph indicate direction and magnitude of the deviation.

Using the Front Panel Controls

The Controller mode is selected with the *Function Select* rotary switch. Color coding relates the switch position to push-button function.

All the Controller *Function Select* modes, except *Pressure*, require selecting a certain sensor channel. For example, when using *Zero Calibration*, it applies only to the channel that the *Gauge Select* rotary switch is set to.

If a channel has no sensor installed or has a sensor that is unsuitable for the selected function, N O appears on its display line selected. At the same time, codes indicating which installed sensors are suitable for the selected function are indicated on the other display lines.

- ◆ CC Cold cathode
- ◆ P I R Pirani
- ◆ C O N Convection
- ◆ T C Thermocouple
- ◆ C A P Capacitance manometer
- ◆ N O Sensor is missing or unsuitable for this function.

Using Function Select

Display Test Mode

A display test is automatically performed for the first few seconds when starting the Controller. To see all display segments at any other time, turn the *Function Select* rotary knob to *Display Test*. This function is also used to review Controller setup.

Reviewing Controller Setup

Review setup following installation of the Series 937A System or any other time you question System configuration. Reviewing setup shows what sensor modules are installed, their channels, as well as settings of most DIP switches and jumpers.

To review your Series 937A Controller setup,

- 1 Turn the *Function Select* rotary switch to *Display Test*.
- 2 Press the *Up* push-button repeatedly to display a sequence of review screens.
- 3 Press the *Down* push-button to display previous review screens.

The sequence and content of setup review screens are shown below. Depending on the configuration of the Controller, some screens may not appear.

Setup Review Screen 1

This screen shows what sensor module is installed in each channel. An indicator, **CC**, **A1**, **A2**, **B1**, or **B2**, appears on the display line of any channel with a sensor module installed. This screen only indicates that a sensor module is plugged in, not whether a sensor is connected to the module. If no module is installed, the channel display remains blank.

Display codes tell what type of sensor module is installed on the channel.

◆	C C	Cold Cathode
◆	P I R	Pirani
◆	C O N	Convection
◆	T C	Thermocouple
◆	C A P	Capacitance Manometer, with valid head setting on DIP switches

C A P appears when the DIP switches are set to any recognized head range. Otherwise, no display appears. Be sure to use the correct switch setting for the head's full scale range. The Controller is unable to detect or report an error of this type. An incorrect reading will result.

The indicator for the units of pressure (**TORR**, **mBAR**, **PASCAL**, or **MICRON**) also appears.

An indicator **U** appears next to any sensor operating with a zero or atmosphere calibration value set by the user with the *Zero* or *ATM Calibration* modes (i.e., not factory-set values).

Cold Cathode non-Standard Configuration Codes

If any symbol appears after *CC* on a display line, it indicates a non-standard configuration of the Cold Cathode module. The different symbols indicate differing degrees of incompatibility between the Cold Cathode module and the Series 937A Controller. These conditions normally result from using modules with incorrectly set jumpers or older versions of the Cold Cathode Module.

A brief description of abnormal Cold Cathode module configuration codes and conditions are listed in the table below. Please perform steps 1-4 before proceeding with the remedies listed in the table.

Since the resolution of these conditions may involve more than one module, it is best to carry out the following steps before attempting to correct individual modules

- 1) Use new Cold Cathode Module (rear connector labeled *Remote*) in the Series 937A Controller. Return older modules (labeled *H.V. Enable*) to 937 controllers with the $\mu P/Com$ jumper set to *Com* if present.
- 2) Use oldest remaining module (labeled *H.V. Enable*) with the lowest revision level (located on PCB assembly) in Slot *CC*.
- 3) Set all module jumpers as described on page 28.
- 4) Recheck configuration codes in *Setup Screen 1*. Evaluate and correct them as described in the table below.
- 5) If the remaining configuration codes are not acceptable, refer to the application note mentioned below. It may be necessary to purchase a new Cold Cathode Module.

If further assistance is required, contact HPS™ Products Applications Engineering and request the application note on *Configuration of Cold Cathode Modules for 929A/937A*.

Code	Condition	Remedy
CC	Module is configured correctly	
CC 8 Reject Module	The high voltage supply of this module cannot be properly controlled	Review Steps 1-3 above
CC (may appear with I) Limited Rear Panel HV Enable function	The rear panel connector of this module provides direct control of the high voltage supply. This input can not be used to enable the high voltage if disabled due to another disable condition	If the input is not needed, this code may be ignored. Otherwise refer to Note 1
CCI (may appear with -) High Voltage Initially On	The controller is configured to turn ON all cold cathode sensors automatically at start-up.	Refer to Note 2
<p>Note 1 If the module has a SW/PS jumper, move it to the SW position. This condition can not be remedied if the module does not have this jumper.</p> <p>Note 2 Set DIP switch #7 on the Analog Module OFF. Consult the applications note before using the ON setting.</p>		

Setup Review Screen 2

This setup review screen is displayed if a capacitance manometer module is installed and its head selection DIP switches have been set to at least one valid selection.

A head range indicator H D appears on the top display line, and **TORR** indicates the full scale range of the head is specified in Torr.

The full scale (highest) pressure reading of each head, as indicated by the module DIP switches, appears on its channel's display line.

Display (Torr)	Full Scale Reading (Torr)	Lowest Reading (Torr)
1.0 X 10 ⁺⁴	10,000	10
1.0 X 10 ⁺³	1,000	1
1.0 X 10 ⁺²	100	0.1
1.0 X 10 ⁺¹	10	0.01
1.0 X 10 ⁺⁰	1	0.001
E R R	Invalid switch setting	

Setup Review Screen 3

This screen is displayed if a capacitance manometer is installed and the head selection DIP switches on the capacitance manometer module have been set to at least one valid head selection.

The auto-zero indicator A U T appears on the top display line. The auto-zero status of each head appears on its channel's display line.

- ◆ O N Auto-zero enabled
- ◆ O F F Auto-zero disabled

Setup Review Screen 4

This screen shows the channel and type of control/combination sensor selected for a cold cathode sensor in Slots CC or A. **CONTROL** will be displayed. The first two lines, CC and A1, indicate the channels selected, B 1 or B 2, for the two control sensors. The B1 and B2 lines indicate the sensor type in the selected control channels.

- ◆ P I R Pirani Sensor
- ◆ C O N Convection Pirani Sensor
- ◆ T C Thermocouple Sensor
- ◆ C A P Capacitance Manometer,
1, 10, or 100 Torr head

If no cold cathode sensor is installed in Slots CC and A, or if the selected control sensor is missing or is unsuitable as a control sensor, N O C T L C H (no control channel) is displayed.

Setup Review Screen 5

Selected time delay for a cold cathode sensor is shown on this screen. The cold cathode sensor delay indicator appears on the top two display lines. One of the following appears on the next two display lines.

- ◆ 3 S E C 3-sec delay selected
- ◆ 3 0 S E C 30-sec delay selected

When a cold cathode sensor high voltage is switched on, this delay allows the discharge to start before set points are activated and processed outputs are updated.

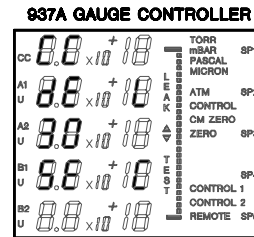

Screen 5

Setup Review Screen 6

This screen shows the *UCAL Enable* switch status and is not affected if calibration by the user is disabled by the optional communications interface. Either of the following appears vertically on the display.

- ◆ U C A L E N A B User calibration enabled
- ◆ U C A L D I S A B User calibration disabled

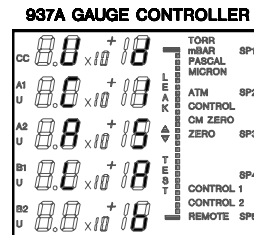

Screen 6

Setup Review Screen 7

The last screen shows line frequency selected.

- ◆ 50 H 50 Hz
- ◆ 60 H 60 Hz

The codes which appear in the bottom lines of the display are the revisions of the Series 937A system software and communications software (if installed)

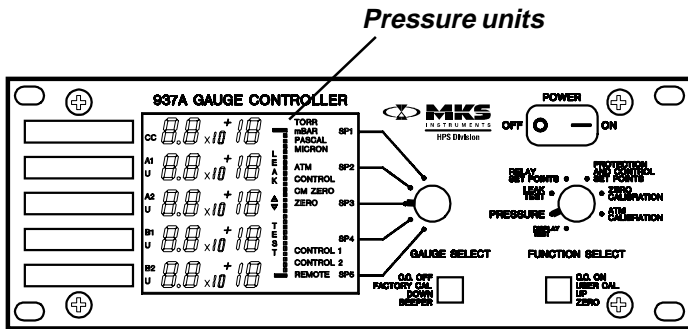

Pressure units

Pressure Mode

Rotate the *Function Select* knob to *Pressure* to display all measured pressures. The Controller displays up to five separate pressure readings. The selected pressure unit is shown in the upper right-hand corner of the display, as shown here. Messages that appear instead of a pressure reading when in Pressure mode are listed below.

C T L with **CONTROL 1** (Slot CC) or **CONTROL 2** (Slot A)

Control - A control sensor is reporting a pressure above the control set point and has turned its cold cathode sensor off.

P R O

Protection - A cold cathode sensor has turned itself off above its protection set point.

O F F

Cold cathode sensor off - A cold cathode sensor is off for reasons other than protection or control.

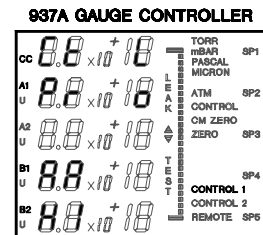

Other messages that appear

H I , L O , A A

Pressure out of range - A sensor is above or below its range, with the exponent digits indicating the true pressure range limit (e.g., L O X 10⁻³, a thermocouple is below its limit of 1.0 x 10⁻³ Torr).

When above its range (or at Atmosphere), a standard Pirani sensor indicates A A X 10^{+ 2} Torr.

Improper connection, Broken sensor wire - A Pirani, thermocouple, or Convection Pirani sensor is improperly connected or its sensor wire is broken.

Calibration error - A capacitance manometer is indicating pressure below 0 Torr.

Cold Cathode Sensor High Voltage

The high voltage of cold cathode sensors can be turned on and off in *Pressure* mode. See page 55 for more information.

Front Panel Control Lock

When the Controller's front panel controls are locked, all panel functions are inactive and the Controller remains in *Pressure* mode. **REMOTE** is displayed.



Most processing in the Controller, including pressure reading, protect and control set points and logarithmic output, is suspended until step 4 is done. Buffered analog output and set point relays continue to work.

To lock or unlock the front panel controls or to display the lock status,

- 1 Set *Function Select* switch to *Pressure* mode and select the bottom display line (B2) with the *Gauge Select* switch.
- 2 Press and hold the *Up* push-button while pressing the *Down* push-button slowly four times. L O C indicates a locked panel, and N O T L O C on the first two lines indicates that it is not locked.
- 3 To change the lock status, hold the *Down* push-button and then press the *Up* push-button once. Continuing to push the *Up* push-button will not continue to toggle between enabled and disabled states.
- 4 Release the *Down* push-button.
- 5 After a few seconds, press the *Up* push-button to return to the pressure function.

The front panel can also be locked or unlocked with optional communications module commands. See *RS232/RS485 Communications Module User's Manual* for more information.

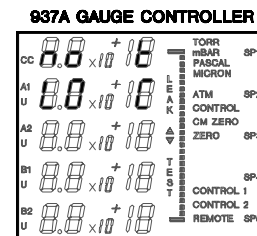

Front panel lock message

Leak Test Mode

Leak Test Mode will work with all sensors except the capacitance manometer, which is not gas dependent. If the *Gauge Select* switch is set to a capacitance manometer or a channel with no module installed, N O will appear in the display line of the selected channel. Channels with sensors capable of leak test will also be indicated on the other display lines.

A 26-segment, centered-zero bar graph shows pressure changes with greater sensitivity than the numerical display. Bar graph resolution is non-linear. The first segment offset from the center is highly sensitive with subsequent segments decreasing in sensitivity.

An optional audio indicator may be turned on and off using the *Beeper* push-button while in the *Leak Test* mode. If enabled, an audio signal indicates changes in indicated pressure due to the probe gas. The repetition of the audio signal will increase as the deviation from the reference pressure increases.

Use the *Zero* push-button to set the bar graph and beeper for a new reference pressure. At the reference pressure, the beeper rate will be less than 1 Hz.

To leak test your system,

- 1 Pump the system to as low a pressure as possible.
- 2 Turn the *Function Select* switch to *Leak Test* and the *Gauge Select* switch to the leak detecting sensor.
- 3 If desired, press the *Beeper* button to enable the audible signal.
- 4 Search the system with a probe gas (not nitrogen or air) slowly and methodically. Always use a probe gas in small quantities to aid in pinpointing the leak. The audio signal begins to beep when the probe gas reaches the sensor, and segments appear on one side of the bar graph zero marker.
- 5 If system pressure drifts or the reading changes, depress the *Zero* push-button to reset the reference pressure reading at any time.



Since set points remain active in the Leak Test function, the probe gas may change the indicated pressure enough to switch the relay state.

If Series 937A Controller power is turned on while set to *Leak Test*, both the communication and calibration locks will be cleared. Note that these locks are not the same as the Front Panel Control locks described on page 47.

See **Appendix B** for more information on leak testing.

Relay Set Points Mode

The *Relay Set Points* mode is used to review and set the pressure at which the set point relays switch.

Five setpoint relays are available; one for Slot *CC* and two each for Slots *A* and *B*. If a single channel module is used in Slots *A* or *B*, both relays are controlled by the first channel of the module. Each setpoint for the slot may be adjusted independently.

The SPDT relay contacts are accessible through the rear panel *Accessory* connector on the power supply module. A mating connector kit is provided with the Series 937A System. The relays are rated for use at 2 A at 30 V. See the table to the left for pin assignments.

SP1 to **SP5** indicators appear when the set point relays are energized. When an indicator is on, the measured pressure on that channel is below the set point value, the normally open relay contact is closed, and the normally closed contact is open. When an indicator is off, the measured pressure is above the set point value, the normally open relay contact is open, and the normally closed contact is closed.

Reading a Relay Set Point

To read the set point value,

- 1 Turn the *Function Select* switch to *Relay Set Points*.
- 2 Set the *Gauge Select* switch to the desired set point.

Set point relays are not disabled while in *Relay Set Points* mode. Set point values can be reviewed without process control interference.

If the *Gauge Select* switch is set to a slot with no module, *N O* will appear on the display line of the selected channel. The channels which do have modules will also be displayed.

The actual relay trip point and the set point displayed may differ due to hysteresis. The hysteresis is most noticeable where the sensor's pressure-vs-voltage curve is relatively flat (near the top or bottom of a pressure range for most sensors).

Setting a Relay Set Point

To change the set point pressures,

- 1 Turn the *Function Select* switch to *Relay Set Points*.
- 2 Set the *Gauge Select* switch to the desired set point.
- 3 Press the *Up* or *Down* push-button to increase or decrease the set point. Holding the button changes the set point faster.

15 Pin Accessory Connector				
Set Point	Channel	Normally Open	Normally Closed	Common
1	CC	2	1	9
2	A1	10	3	11
3	A2	12	4	5
4	B1	13	6	14
5	B2	7	8	15

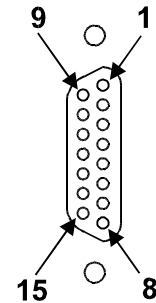

Male, 15-pin "D" Accessory connector

A new set point takes effect and is saved in nonvolatile memory when either the *Function Select* or the *Gauge Select* switch is turned to another position. The new set point is not saved if the Controller is turned off before turning one of these switches.



Care should be taken when storing the new set point pressure since the relay may change state.

Disabling a Relay Set Point

To disable a set point, set it to 0.0. To set this value,

- 1 Turn the *Function Select* switch to *Relay Set Points*.
- 2 Set the *Gauge Select* switch to the desired set point.
- 3 Press and hold the *Down* push-button until the set point is at the bottom of its range.
- 4 Release and depress the *Down* push-button once. The set point will decrement to 0.0.
- 5 Press the *Up* push-button to restore the set point and return it to the sensor's range.

Set points are factory preset to 0.0, the disabled setting.

Relay Inductive Loads and Arc Suppression

If the set point relay is used to switch inductive loads, e.g., solenoids, relays, transformers, etc., arcing of the relay contacts may interfere with Controller operation or reduce relay contact life. Therefore an arc suppression network, shown schematically below, is recommended. The values of the capacitance C and the resistance R are calculated by the equations,

$$C = \frac{I^2}{10} \quad \text{and} \quad R = \frac{E}{10 \cdot I^a}$$

where,

$$a = 1 + (50/E)$$

C is in microfarads

R is in ohms

I is DC or AC_{peak} load current in amperes

E is DC or AC_{peak} source voltage in volts.

$$C_{min} = 0.001\text{mF} \quad \text{and} \quad R_{min} = 0.5 \text{ W.}$$

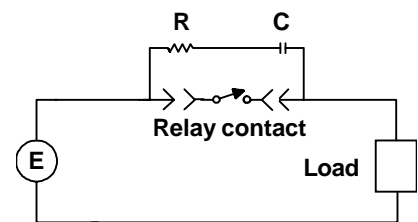

Relay arc suppression network

Protection and Control Set Points Mode

This section describes how to use the *Protection and Control Set Points* mode to adjust these set points with cold cathode sensors. See **Cold Cathode Operation**, page 55, for additional information.

Setting a Protection Set Point

To select a protection set point,

- 1 Turn the *Function Select* switch to *Protection and Control Set Points*.
- 2 Set the *Gauge Select* switch to a cold cathode sensor.

The protection set point is displayed on the cold cathode channel. P R O is displayed below it. If a control sensor is also used, its control set point is displayed on the control channel for comparison.

- 3 Press the *Up* or *Down* push-button to adjust the value accordingly. Hold either button to change it more rapidly.

To review a set points without affecting any output, turn the *Function Select* or *Gauge Select* switch to another position without changing the displayed value.

A new set point takes effect and is saved in nonvolatile memory when either the *Function Select* or the *Gauge Select* switch is turned to another position. The new set point is not saved if the Controller is turned off before turning one of these switches.

Setting a Control Set Point

If a common sensor is configured to control two cold cathode sensors, the two control setpoints are set independently.

To select a control set point,

- 1 Turn *Function Select* switch to *Protection and Control Set Points*.
- 2 Set the *Gauge Select* switch to a control sensor on channel B1 or B2.

The control set point is displayed on the control channel line. C T L is displayed on the other display line of Slot B. The protection set point is also displayed on the cold cathode line for comparison.

When the same sensor is configured to control two cold cathode sensors, both control set point values will appear on the control sensors display line. Switching between channel B1 and B2 with the *Gauge Select* switch selects which control set point is displayed. Selecting channel B1 with the *Gauge Select* switch displays the control set point for Slot CC. Selecting channel B2 with the *Gauge Select* switch displays the control set point for Slot A.

Protection Set Point

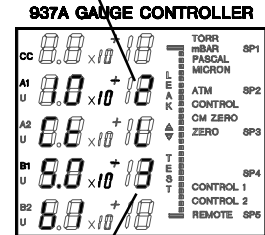

Control Set Point

In either case, the control set point value is always displayed on the line for the channel that is configured as the control sensor. When the selected channel is not the same as the configured control channel, B1 or B2 will appear on the selected display line of Slot B to indicate which channel is the configured control channel.

Protection Set Point

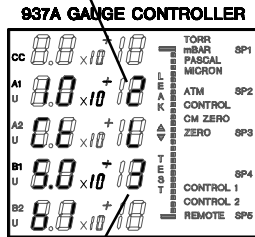

Control Set Point

The display to the left shows an example of this type of configuration. The control channel is B1. The *Gauge Select* switch is set to channel B2. Therefore, the value of the control setpoint is displayed on channel B1 and B1 is displayed on line B2 indicating that channel B1 is the control channel.

- 3 Press the *Up* or *Down* push-button to adjust the value accordingly. Hold either button down to change it more rapidly.

A new set point takes effect and is saved in nonvolatile memory when either the *Function Select* or the *Gauge Select* switch is turned to another position. The new set point is not saved if the Controller is turned off before turning one of the switches.

To review a set point without affecting any output, turn the *Function Select* or *Gauge Select* switch to another position without changing the displayed value.

Protection and Control Set Point Messages

Whether a cold cathode sensor or a control sensor is selected, both control and protection set points will be displayed. Only the set point selected with the *Gauge Select* switch will be adjustable. If there is no control sensor, only the protection set point appears.

When a channel without a protection or control set point is selected, messages giving the protection/control set point configuration for each channel appear.

Protection and Control Set Point Display Messages	
No	Channel does not have a protection or control set point. When this message appears, select another channel to display a set point
No on all display	No cold cathode sensor module installed in Controller. No protection or control set points are available.
CC	Channel has a cold cathode sensor installed
C1 on line B1 or B2	Channel controls the cold cathode sensor in Slot CC.
C2 on line B1 or B2	Channel controls the cold cathode sensor in Slot A.
C12 on line B1 or B2	Channel controls the cold cathode sensor.
B1 on line B2 or B2 on line B1	Channel B1 or B2 actually controls both cold cathode sensors, regardless of Gauge Select switch and set point display position.
CONTROL 1 / CONTROL 2	Control set point for slot CCI Slot A is active.
PRO	Selected set point is a protection set point.
CTL	Selected set point is a protection set point.

Disabling a Protection or Control Set Point

- 1 Set the *Gauge Select* switch to the desired set point.
- 2 Hold the *Down* push button until the set point is at the bottom of its range.
- 3 Release and depress it once more. The set point will decrement to 0.0.
- 4 Press *Up* to return the value to the bottom of the range.

Setting a set point to 0.0 deactivates it. Protection and Control set points are factory preset to 0.0.

Zero and ATM Calibration Modes

Calibration may be necessary if the vacuum or atmosphere reading of the sensor has drifted or a sensor has been replaced. The calibration provided by the Series 937A controller is designed to improve the accuracy of the sensor; however, it does not provide a NIST traceable calibration. Also, this feature is not intended to correct the output of the sensor for different gases.

In order to perform a calibration (except for capacitance manometer), the *UCAL Enable/Disable* switch on the rear panel of the Analog Module must be set for Enable (page 32). If it is not, **U C A L D I S A B** will be displayed in the *Zero* or *ATM Calibration* mode indicating that the calibration can not be changed.



The UCAL Enable / Disable switch does not reset a sensor to its factory calibration. It simply allows or prevents changes to existing sensor calibration.

Calibration can also be enabled or disabled with the optional Communications Module. If disabled, the **REMOTE** indicator will appear and **U C A L D I S A B** will be displayed. In this case, send the command **ECAL** to the Communications Module. Enabling calibration can also be done from the front panel by turning the *Function Select* switch to *Leak Test*, turning the power off for 5 seconds, and turning the power back on.

If the *Gauge Select* switch is set to a channel that cannot be calibrated, **N O** will appear on its display line, and channels with suitable sensors will be indicated. There is no calibration provided for the cold cathode sensor and only zero calibration is provided for the capacitance manometer.

There are two types of calibration, Factory and User.

Factory Calibration resets the calibration value for the selected channel to the factory default for the sensor type installed. If the sensor module type or the capacitance manometer head range is changed on the Analog Module, the calibration will be reset to the factory value when the controller is turned on.

937A GAUGE CONTROLLER

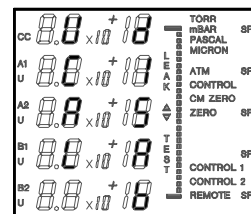

User Calibration establishes the current reading from the sensor as the new calibration value. The calibration value is stored in non-volatile memory and is restored when the Controller is turned on. When user calibration is in effect for either zero or atmosphere, a **U** indicator will appear next to the channels display line.

Zero Calibration Mode

To perform Factory Calibration

- 1 Turn the *Function Select* switch to *Zero Calibration*.
- 2 Set the *Gauge Select* switch to the desired channel.
- 3 Press the *Factory Cal* push-button to set the zero value to the factory default.

If the sensor is still calibrated for atmosphere by the user, the **U** remains visible. Otherwise, the **U** indicator is not displayed.

To perform User Calibration

- 1 Pump the system to a pressure of less than 1×10^{-5} Torr or less than 3% of the sensors lower limit. Allow the sensor to stabilize for at least 10 minutes.
- 2 Turn the *Function Select* switch to *Zero Calibration*.
- 3 Set the *Gauge Select* switch to the channel to be calibrated.

The mode indicator **ZERO** appears and the sensor's pressure reading is continuously displayed. The bar graph display is activated to indicate the difference between the sensor signal and its present zero calibration value. For a capacitance manometer, each segment represents .05% of full scale.

- 4 Press and release the *User Cal* push-button to save the current vacuum reading as the new zero value. The display pressure is reset to 0.0. and all bar graph segments are cleared. The indicator **U** will appear next to the display of the channel.



A considerable zero calibration change may activate or deactivate a sensor's set point and shift various pressure output readings.

The Series 937A Controller does not allow user calibration when the reading is outside the appropriate range. **OUT** momentarily appears on the display if the pressure is out of the allowable calibration range. In this case, the new calibration value will not be accepted. If a previous user calibration value had been stored, the value will be retained and the **U** remains visible.

The voltage of the capacitance manometer must be within ± 50 mV of 0V. If the sensor voltage exceeds this range, a new calibration value will not be accepted. Refer to the zero adjustment procedure in the capacitance manometer instruction manual. The zero calibration of the capacitance manometer will result in the output shifting over the full range of the head.



A special calibration algorithm in the 937A allows independent zero and atmosphere calibration adjustments for Pirani, Convection Pirani and thermocouple sensors.

Capacitance Manometer Auto-Zero Feature

The auto-zero feature continuously resets the zero of a capacitance manometer when the cold cathode sensor in Slot CC indicates system pressure is low enough. The capacitance manometer and the cold cathode sensor should be closely located on the vacuum system and exposed to roughly the same system pressure.

To enable auto-zeroing, set DIP Switch 4 for either head on the capacitance manometer module to *On* (page 29). The cold cathode sensor in slot CC must be on and its pressure reading must be ,

- ◆ less than 1.0×10^{-2} Torr, the high end of the cold cathode sensor's measurement range, and
- ◆ less than 0.005% of full scale for the capacitance manometer's Torr head (5% of its minimum reading), e.g., 5.0×10^{-5} Torr for a 1 Torr head.

If the above conditions are true, and the capacitance manometer signal is within range, a new zero is set each time the capacitance manometer signal is read. **CM ZERO** and L O on the capacitance manometer's channel line both appear on the display.

As soon as any one of the required conditions ceases to be true, auto-zeroing stops and the last valid zero reading is used until all conditions are again true.

Allow the Controller to stay in auto-zero mode for at least 30 sec before taking it to a pressure above the auto-zero pressure. The capacitance manometer needs this time to stabilize.

The voltage of the capacitance manometer must be within $\pm 50\text{mV}$ of 0V. If the sensor voltage exceeds this range, a new calibration value will not be accepted. Refer to the zero adjustment procedure in the capacitance manometer instruction manual.



The zero value determined by auto-zero calibration is not saved in nonvolatile memory and is lost when the Controller is turned off.

The zero calibration which is stored in non-volatile memory is not changed by the auto-zero feature. If a manual zero calibration is carried out during auto-zeroing, the selected zero value will be stored as usual, but will not affect the pressure measurement. The saved reading will be used when the Controller power is next turned on, until auto-zeroing resumes. This allows a calibration saved during auto-zeroing to become the default zero value.

ATM Calibration Mode

Atmosphere calibration is provided for the Pirani, Convection Pirani and thermocouple sensors. Please refer to the next section for calibration of the Convection Pirani sensor.

To perform Factory Calibration

- 1 Turn the *Function Select* switch to *ATM Calibration*.
- 2 Set the *Gauge Select* switch to the desired channel.
- 3 Press the *Factory Cal* push-button to set the atmosphere value to the factory default.

If the sensor is still calibrated for zero by the user, the **U** remains visible. Otherwise, the **U** indicator is not displayed.

To perform User Calibration

- 1 Vent the system to atmospheric pressure or back fill it with air/nitrogen using a reference sensor to avoid overpressure. Allow sensor to stabilize for at least 10 minutes.
- 2 Turn the *Function Select* switch to *ATM Calibration*.
- 3 Set the *Gauge Select* to the channel to be calibrated.
- 4 Press and release the *User Cal* push-button to save the current sensor pressure as the new atmospheric value.

The pressure reading will be displayed as AA for a Pirani and H I for a thermocouple sensor. The indicator **U** will appear next to the display of the channel.



A considerable atmospheric calibration change may activate or deactivate a sensor's set point and shift various pressure output readings.

The Series 315 Pirani sensor exhibits slight convection characteristics near atmosphere. Therefore, the best accuracy can be achieved above 30 Torr by calibrating the sensor oriented vertically with the port facing down. The Pirani and thermocouple sensors can be calibrated at any pressure between 600 and 1000 Torr.

The Series 937A Controller does not allow user calibration when the reading is outside the appropriate range. OUT momentarily appears on the display if the pressure is out of the allowable calibration range. In this case, the new calibration value will not be accepted. If a previous user calibration value had been stored, the value will be retained and the **U** remains visible.



A special calibration algorithm in the 937A allows independent zero and atmosphere calibration adjustments for Pirani, Convection Pirani and thermocouple sensors.

Calibrating the Convection Pirani Sensor for Atmosphere

Since the Series 317 Convection Pirani sensor gives numerical pressure readings at atmospheric pressure, the local atmospheric pressure must be determined in order to correctly calibrate the sensor. Atmospheric pressure depends on altitude and to a lesser degree, weather systems and climate control (HVAC systems).

There are two methods to calibrate the Convection Pirani sensor at atmosphere with the Series 937A Controller.



A considerable atmospheric calibration change by either method may activate or deactivate a sensor's set points and shift various pressure output readings.

Method 1

If the local atmospheric pressure is 760 ± 2 Torr, or the system pressure can be controlled to 760 ± 2 Torr, then the user calibration procedure in the previous section may be used to calibrate the Convection Pirani sensor.

After pressing and releasing the *User Cal* push-button in step 4, the display will read 7.6×10^2 Torr and the indicator **U** will appear next to the display of the channel.

This method assumes the sensor is exposed to 760 Torr of air/nitrogen. If the Convection Pirani sensor is calibrated using this method at pressures other than 760 Torr, errors will result. These errors are largest between 30 and 200 Torr, where the sensor has the least amount of sensitivity. Below 10 Torr, the differences are less than 10 percent.

Method 2

If local atmospheric pressure is not 760 Torr, atmosphere calibration at other pressures can be achieved by adjusting the potentiometer on the rear panel of the Convection Pirani module. A reference sensor such as a capacitance manometer is required to determine local atmospheric pressure.



Once the potentiometer has been adjusted, the original calibration of the channel is lost. You must continue to use this method until the channel is recalibrated at 760 Torr using the procedure below. Using the normal factory and user calibration procedures after adjusting the potentiometer will result in slight errors in the pressure reading.

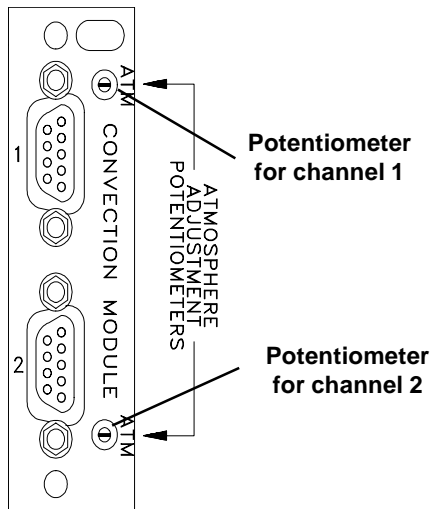

Location of atmosphere adjustment potentiometers on rear panel

- 1 Vent the system to atmospheric pressure or back fill it with nitrogen using a reference sensor to avoid overpressure. Allow the sensor to stabilize for at least 10 minutes.
- 2 Turn *Function Select* switch to *ATM Calibration*.
- 3 Set the *Gauge Select* switch to the channel to be calibrated.
- 4 Press the *Factory Cal* push-button to reset the atmosphere value to the factory default.
- 5 While monitoring the display, adjust the rear panel potentiometer until the pressure value displayed agrees with the reference sensor.
- 6 Calibrate the sensor at vacuum using ***User Zero Calibration*** procedure.



Using Method 2, zero and atmosphere calibrations are not independent. Unless the changes are small, it may be necessary to repeat this procedure due to the interaction between the two adjustments.

Re-calibration of sensor channel at 760 Torr.

Use this procedure to adjust sensor channel back to the factory setting so the standard atmosphere calibration procedure may be used.

- 1 Set atmosphere calibration value to the factory default value.
- 2 Vent or control the system pressure to 760 ± 2 Torr.
- 3 Adjust the potentiometer until the pressure displayed on the front panel is 7.6×10^2 Torr.

Cold Cathode Operation

The cold cathode sensor is turned on and off by switching the high voltage to the sensor on and off. A cold cathode sensor is not automatically turned on when the Series 937A Controller is turned on.

When cold cathode sensors are turned on at low pressures, the discharge current does not start immediately. The 3 or 30 second output delay selected on the Analog Module prevents the activation of the cold cathode sensor's set point relays and maintains outputs in the OFF condition until the delay has expired. After the selected delay, the pressure may be reported as LO if the cold cathode sensor has still not started.

Prolonged operation at higher pressures will degrade the performance of the sensor. This is due to contamination of the sensor, which reduces the operating time before the sensor requires cleaning.



Operation at pressures above 5×10^1 Torr will result in the sensor falsely indicating a much lower pressure. This phenomenon is called rollback. Operating conditions that could cause rollback should be avoided.

The high voltage for the cold cathode sensor can be controlled by six methods.

- 1 *CC On/Off* push buttons on the front panel
- 2 The Remote connector on the rear panel of the Cold Cathode Module.
- 3 The connector on the rear panel of the Analog Module (Slot *CC* only).
- 4 Commands sent to the Series 937A Communications Module
- 5 *Protection Set Point* (sensor automatically controlled by 937A)
- 6 *Control Set Point*(sensor automatically controlled by 937A)

C.C. On/C.C. Off Front Panel Push-Buttons

- 1 Turn the *Function Select* switch on the front panel to *Pressure*.
- 2 Set the *Gauge Select* switch to a cold cathode sensor.
- 3 Press the *C.C. On* or *C.C. Off* push-button to turn the sensor on or off, respectively.

If the sensor has been turned off by the protection set point (PRO displayed), it will be necessary to press *C.C. Off* once before pressing *C.C. On* to turn on the sensor.

Cold Cathode Module Remote Connector

The cold cathode sensor may be turned on or off from the rear panel of the Cold Cathode Module. Connect pin A to pin D on the *Remote* connector to turn the sensor off. Once pins A and D are connected, the sensor can be turned on by disconnecting pins A and D. If this input does not operate as expected, refer to page 40 **Cold Cathode non-Standard Configuration**.

Analog Module

Connect pin 13 to pin 25 of the 25-pin "D" connector on the Analog Module to turn off a cold cathode sensor in Slot *CC*. Once pins 13 and 25 are connected, the sensor can be turned on by disconnecting pins 13 and 25.

Communications Module (optional)

Send command **ECCn** to turn the sensor on or **XCCn** to turn the sensor off where n is 1,2,or 4 representing the first channel of Slot *CC*,A or B respectively. See *Series 937A Communications Module User's Manual* for more information.

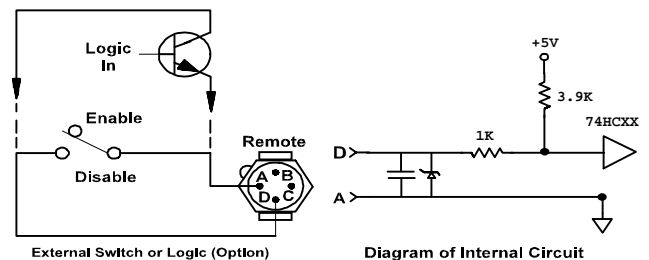

Cold Cathode Sensor Remote

If a cold cathode sensor has been disabled using the **XCCn** command, the **ECCn** command must be used to re-enable the sensor. No other method can override the **XCCn** command. In the event that the cold cathode can not be re-enabled from the Communications Module, the power switch on the Series 937A controller must be turned off (for at least 5 seconds) and then turned on again. This will clear the disable condition from the Communications Module.

Using Protection and Control Set Points

The Series 937A controller has two pressure-based methods, protection and control set points, to automatically turn off a cold cathode sensor's high voltage in the upper portion of the operating range.

In the first method, if the pressure measured by a cold cathode sensor rises above a protection set point, the sensor will turn itself off. PRO appears on the display in *Pressure* mode. The user must use one of the methods from the previous sections to turn the cold cathode sensor off, and then back on.

In the second method, a sensor other than a cold cathode sensor may be designated as a control sensor. If the control sensor's pressure reading rises above the control set point, the cold cathode sensor will turn off. C T L appears on the display in *Pressure* mode. When the pressure falls below the control set point, the cold cathode sensor automatically turns on again.

The control set point will only turn on the cold cathode sensor as the pressure falls below the set point value, if it was first turn off by the control set point. The control set point can not turn on the cold cathode sensor if it was turn off for another reason. This includes the off state when the 937A is initially turned on. Therefore, after power up the cold cathode must be turned on by one of the methods previously mentioned before the control set point will function.

To use a control set point, a cold cathode sensor must be in Slot CC or A. Its control sensor must be installed in either channel of Slot B, selected by the DIP switch setting on the Analog Module.

Sensors that can be used as a control sensor are the Pirani, Convection Pirani, and thermocouple sensors. In addition, the 1, 10, and 100 Torr capacitance manometer heads may be used as control sensors. If there is no control sensor installed, no control set point will be available.

If a Pirani, Convection Pirani or thermocouple sensor is used as a control sensor, and it is disconnected or fails, the controlled cold cathode sensor will be turned off just as if the control sensor's pressure reading had exceeded the control set point.



For a control sensor to properly control a cold cathode sensor, both sensors should be sensing roughly the same system pressure.



If the system gas is not air/nitrogen, the cold cathode sensor and the control sensor may not agree near the control set point, since both sensors are gas dependent.

Choosing between the protection and control set points depends upon several factors, including the need for automatic start-up, and the possibility of the pressure rising into the rollback range.

 **The reading from a cold cathode sensor will "roll back", or indicate a false low pressure, when operated above 5.0×10^{-1} Torr. This prevents a protection set point from switching the sensor off if the pressure rises too quickly or when the sensor is turned on above 5.0×10^{-1} Torr. Above this pressure, a cold cathode sensor can be turned off automatically by a control set point only.**

Both types of set points may be used with one exception. No control set points are available if a Cold Cathode Module is in Slot B.

Determining Protection and Control Set Points

The range for the protection set point is 1×10^{-5} to 1×10^{-2} Torr.

For the Pirani, Convection Pirani or thermocouple sensors, the lower limit of the control set point is the same as the lower limit of the relay set point. For a capacitance manometer, the lower limit of the control set point is one-half of the relay set point lower limit, or 0.5% of full scale. The upper limit for the control set point for any sensor is 9.5×10^{-1} Torr.

Comparison of Control Set Point and Protection Set Points		
	Protection	Control
Operation	CC sensor turns itself off	CC sensor is turned off by a Control sensor
Advantage	<ul style="list-style-type: none"> a) No additional sensor required b) Lower minimum set point 	<ul style="list-style-type: none"> a) CC sensor will be turned on automatically at an acceptable pressure as determined by the control sensor b) Control sensors not affected by rollback. c) Higher maximum set point.
Disadvantages	<ul style="list-style-type: none"> a) User must determine when to restart the sensor. b) User must re-started the sensor using the front panel or other external signal c) CC sensor may be affected by rollback, which makes it unable to turn itself off. 	<ul style="list-style-type: none"> a) Separate control sensor is required. b) If the two sensors are not exposed to the same pressure, the cold cathode sensor could be turned on accidentally at a pressure above its operating range. This could lead to rollback.
Set Point Range	1×10^{-5} to 1×10^{-2} Torr	2×10^{-3} to 9.5×10^{-1} Torr (with suitable sensor)



When using a control set point near the lower limit, check the zero calibration and correct if necessary (see page 49).

If a control set point is used, disable the protection set point or set it to a higher value than the control set point. Otherwise, the protection set point will override the control set point, preventing automatic start-up of the cold cathode sensor when the pressure falls back below either set point.

When a protection and a control set point are used together, consider their interaction with one another when choosing their values. If,

- ◆ *the two sensors measure the same pressure and are properly calibrated,*
- ◆ *the pressure never changes rapidly, and*
- ◆ *the cold cathode sensor is never turned on when the pressure is too high*

then only the lower of the two set points will ever operate. If any of these conditions are not true, both set points might be active at different times.

See page 48 for information on setting protection and control set points.

Information Update Rate

The A/D converter has a conversion time of 50 msec. The total pressure update cycle in either *Pressure* or *Leak Test* modes is the number of sensors multiplied by 50 msec, e.g., if 5 sensors are operating, the display and the logarithmic output for each sensor are updated every 250 msec.

When the Controller is in a mode other than *Pressure* or *Leak Test*, the update rate is 100 msec per sensor rather than 50 msec. Therefore, it is preferable to leave the Controller in *Pressure* mode.

The sensor update rate may be suspended briefly while the Controller is self-calibrating, while rotary switches are turned or buttons are pressed, and while entering calibration values into nonvolatile memory. These time suspensions are infrequent and always less than a second.

Outputs will remain at the present value for a few hundred milliseconds until sampling resumes.

These time suspensions do not apply to the buffered analog output or to the relay set points, which are not affected by the update rate.

While reviewing or changing front panel lock status, all software driven Controller functions are suspended (see Front Panel Control Lock, page 44). Relay set points and buffered analog output continue to function normally.

Controller Analog Output

The chart identifies the pins of the female, 25-pin "D" connector on the Analog Module.

Buffered and logarithmically scaled analog outputs are available from each sensor. Wide range combination output is also available from each cold cathode sensor with a combination sensor.

For twisted pair connection, an analog ground pin is provided for each output signal. The Analog Module connector also has a high voltage disable input and ground for the Slot CC Cold Cathode Module.

Pin	Description
1	analog output, combination, channel CC
2	analog output, buffered, channel CC
3	analog output, buffered, channel A1
4	analog output, buffered, channel A2
5	analog output, buffered, channel B1
6	analog output, buffered, channel B2
7	analog output, logarithmic, channel CC
8	analog output, logarithmic, channel A1
9	analog output, logarithmic, channel A2
9*	analog output, combination, channel A1
10	analog output, logarithmic, channel B1
11	analog output, logarithmic, channel B2
12	not used
13	cold cathode disable, slot CC
14-24	analog ground
25	cold cathode disable return, slot CC

*** Pin 9 provides this function only when a cold cathode sensor is installed in slot A.**

Buffered Output

See **Appendix C** for voltage-vs-pressure curves from the buffered analog output for each sensor. These signals are not affected by vacuum or atmospheric calibration. The table below shows analog output values for various sensor conditions.

If Buffered Output is	Then	
0 to 10 V	Normal Range	
< 0 V	Cold Cathode	No discharge or a pressure reading of less than
	Capacitanc Manometer	Reading below 0 Torr (zero adjustment at head may be needed)
> 10 V	Cold Cathode	High voltage disabled
	Thermocouple	Not properly connected

Logarithmic Output

Logarithmic output is scaled for 0.6 V per decade of pressure. Only one curve is needed to determine the pressure from the logarithmic output for any sensor (see **Appendix C**). For example, at 1.0×10^{-3} Torr, a Pirani sensor will have the same logarithmic voltage output value, 5.4 V, as a cold cathode sensor.

V (volts)	P(Torr)	V(volts)	P(Torr)
0.6	1.0×10^{-11}	5.4	1.0×10^{-3}
1.2	1.0×10^{-10}	6.0	1.0×10^{-2}
1.8	1.0×10^{-9}	6.6	1.0×10^{-1}
2.4	1.0×10^{-8}	7.2	1.0×10^0
3.0	1.0×10^{-7}	7.8	$1.0 \times 10^{+1}$
3.6	1.0×10^{-6}	8.4	$1.0 \times 10^{+2}$
4.2	1.0×10^{-5}	9.0	$1.0 \times 10^{+3}$
4.2	1.0×10^{-4}	9.6	$1.0 \times 10^{+4}$

The pressure P as a function of voltage V

$$P = 10 \left(\frac{V}{0.6} - 12 \right)$$

$$V = 0.6 [\log_{10}(P) + 12]$$

is calculated by the equation,

Inversely,

where,

P is in Torr
 V is in volts.

For example, if $V = 5$ V, then $P = 10^{(8.33-12)} = 10^{-3.67} = 2.0 \times 10^{-4}$ Torr.

A data acquisition system with a 12-bit A/D converter and an input range of 0 to 10 V will have enough resolution to resolve the equivalent of 1% of reading in the logarithmic output.

<i>If Logarithmic Output Is</i>	<i>Then</i>
0.6 to 9.6 V	Normal range
0.2 V	Sensor exposed to a pressure less than in its measurement range (LO displayed)
9.8 V	Sensor exposed to a pressure higher than in its measurement range (HI displayed)
10 V	Thermal conductivity sensor not connected properly or filament is broke
10V	Cold cathode high voltage disabled
10V	No sensor on a channel
10V	Immediately after the Series 937A Controller is switched on
0 V	When the Controller is not powered, but never when power is on

Combination Logarithmic Output



A combination sensor is a control sensor with a range that overlaps the range of the cold cathode sensor. This excludes the 10 and 100 Torr capacitance manometer heads. Refer to page 30 for the selection of control/ combination sensors.

A combination output combines the measurement ranges of a cold cathode sensor and its combination sensor. For example, if a Convection Pirani sensor is used as the combination sensor, then the combination output provides a voltage representing pressures ranging from 1×10^{-11} to 1000 Torr. The combination output is logarithmically scaled as described in the preceding section. A smoothing formula is used where sensor ranges overlap.

A combination output is provided for each cold cathode sensor that has a combination sensor. Pin 1 of the Analog Module rear panel connector is used for the combination output of the cold cathode sensor in Slot CC. If there is no cold cathode in Slot CC, the output will be 10V. The second combination output will be provided on Pin 9 if a cold cathode sensor is in Slot A and it has a valid combination sensor.

While the cold cathode sensor is disabled, the combination output will have the same value as the logarithmic output of the combination sensor. This is also true for the 3 or 30 second delay immediately after the high voltage is switched on. When both sensors are operating normally, the combination output will be determined by the first of the following conditions which is true:

- ◆ *If the combination sensor's pressure is greater than 3.0×10^{-3} Torr (5.686 V), the combination output will have the same value as the logarithmic output of the combination sensor*
- ◆ *If the cold cathode sensor's pressure is less than 7.0×10^{-5} Torr (4.707 V), the combination output will have the same value as the logarithmic output of the cold cathode sensor*
- ◆ *Otherwise, the output will be a processed combination of the two sensor signals.*

If there is no combination sensor or if it is not properly connected (--- displayed), the combination output will be 10V.

If the combination sensor is inappropriate, the output will be the voltage corresponding to the ion gauge pressure.

Error Messages

The Series 937A Controller is designed to be maintenance free with normal operation. Three types of Controller errors may be detected when the Controller is turned on – ROM checksum, EEPROM correction data, and module or sensor setup. These errors are different from sensor error messages.

When the Series 937A Controller is first turned on, the main program and the optional Communications Module's program check the contents of their software ROMs for changes.

Main Program Checksum Test

The main program performs a checksum test to test the contents of its program ROM. If no error is found in the main program ROM, then the software turns on all display segments for about 4 sec.

Next, the display clears, and one or both of the correction and setup error messages could appear on the display.

If the checksum test finds an error, the Controller beeps intermittently. No other functions are possible. Contact HPS™ Products Customer Service to correct this problem.

Communications Module Program Checksum Test

The program in the optional Communications Module also performs a checksum test. If the checksum test finds an error, no communications functions are possible. Other Controller functions will operate normally.

With RS-232 communications, the data output pin (pin 3 of the upper connector) will change state nearly every second. This will cause framing errors in the host system. See the *RS-232/RS-485 Communications Module User's Manual* for more information.

Nonvolatile Memory Error in Correction Factors

A serial EEPROM saves various types of data, including set point, user calibration, and correction values, when the Controller is turned off. To prevent data corruption, an EEPROM with inadvertent write protection has been used and the Series 937A Controller software has an error detection and correction scheme. Consequently, the message CORR ERROR is extremely unlikely.

Correction values are written to the EEPROM when the microprocessor module is calibrated at the factory, and they are never modified. The microprocessor uses these values to correct for voltage error up to 0.16% due to the tolerance of the divider resistors at the input of the A/D converter. In the unlikely event the correction values cannot be recovered, the message CORR ERROR appears vertically on the display.

1 Press the *Up* push-button once to cancel the message.

CALL HPS™ appears on the screen next.

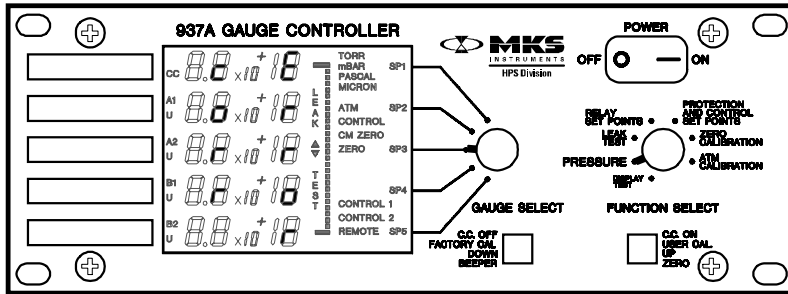

2 Press the *Up* push-button to cancel this message.

The Controller will now work normally, except the correction factors are lost and can no longer correct the affected channel's A/D readings. This can cause a reading error up to +100%/-50% at pressures where sensor curves are relatively flat (near the top or bottom of a pressure range for most sensors).

Setup Error

The message SETUP ERROR means at least one of two setup errors has occurred.

- ◆ *An invalid capacitance manometer head DIP switch setting was detected (see p. 29).*
- ◆ *No recognized modules are plugged into the Controller.*

Push the *Up* push-button to cancel the message.

The Controller will ignore the incorrectly configured module. Note that this does *not* detect a mismatch between the DIP switch setting and the head connected. This type of error cannot be detected, and an incorrect reading will result.

It is possible that a capacitance manometer module with the first setup error is plugged in or that a module of type other than cold cathode is in slot CC. These are not recognized.

Pushing the *Up* push-button will not cancel the message if no valid module is in the Controller and pressure cannot be measured.

Quick Reference Tables

Table I Front Panel Operation

Effect of *Gauge Select* switch and push-buttons in the seven primary functions.

	Set <i>Gauge Select</i> Switch to	Push Front Panel Push-button to		Numerical Display Shows
		Left	Right	
Display Test	Any sensor	Reverse thru screens	Forward thru screens	Setup review screens sequentially
Pressure	Any CC sensor	Turn CC sensor off	Turn CC sensor on	Pressure from all sensors
	Channel B2 to enter Panel Lock mode	Hold right button and press left 4 times to show lock state	Hold left button and press right once to change lock state	LOC or NOT LOC NOT LOC or LOC
Leak Test	Any leak test sensor	Toggle beeper on/off	Zero bar graph and beeper rate for present reading	Pressure from leak test sensor
Relay Set Points	Any sensor	Decrease	Increase	Adjusted value, 0.0 if disabled
Protection and Control Set	Any CC or control sensor	Decrease	Increase	Value and type selected, 0.0 if disabled
Zero Calibration	Any sensor except CC	Return to factory calibration	Save new calibration	Sensor pressure or 0.0 (or U C A L D I S A B)
Atm Calibration	Any sensor except a CC or CM			Sensor pressure, A A, or H I (or U C A L D I S A B)

Table II Setpoint Values

Pressure values below are specified in Torr. Numerical values of the limits will change depending upon the units selected; however, the actual pressure of the limits will be the same.



Values are not adjusted when units are changed. They will retain the same numerical value in the new units, which is not the same pressure. Values should be reset after changing units.

Relay Setpoints

<u>Sensor</u>	<u>Lower Limit</u>	<u>Upper Limit</u>
Cold Cathode	2.0×10^{-10}	9.5×10^{-3}
Convection Pirani	2.0×10^{-3}	$9.5 \times 10^{+2}$
Pirani	2.0×10^{-3}	$9.5 \times 10^{+1}$
Thermocouple	2.0×10^{-3}	9.5×10^{-1}
Capacitance Manometer	1.0% FS	95% FS
1T	1.0×10^{-2}	9.5×10^{-1}
10 T	1.0×10^{-1}	$9.5 \times 10^{+0}$
100 T	1.0×10^0	$9.5 \times 10^{+1}$
1000 T	$1.0 \times 10^{+1}$	$9.5 \times 10^{+2}$
10000T	$1.0 \times 10^{+2}$	$9.5 \times 10^{+3}$

Control Setpoints

<u>Sensor</u>	<u>Lower Limit</u>	<u>Upper Limit</u>	<u>combination</u>
Convection Pirani	2.0×10^{-3}	9.5×10^{-1}	yes
Pirani	2.0×10^{-3}	9.5×10^{-1}	yes
Thermocouple	2.0×10^{-3}	9.5×10^{-1}	yes
Capacitance Manometer	.5% FS		
1T	5.0×10^{-3}	9.5×10^{-1}	yes
10 T	5.0×10^{-2}	9.5×10^{-1}	no
100 T	5.0×10^{-1}	9.5×10^{-1}	no



The specified value is the pressure at which the cold cathode sensor is turned on as the pressure is falling. When the pressure is rising, the cold cathode sensor is turned off at 1.05 times the control set point value.

Protection Setpoint

<u>Sensor</u>	<u>Lower Limit</u>	<u>Upper Limit</u>
Cold Cathode	1.0×10^{-5}	1.0×10^{-2}

Spare Parts and Accessories

	<i>Part #</i>
Accessory Connector Kit	100005087
Cable for Capacitance Manometer, Type 122A/622A	
10 ft (3.0 m)	100007550
25 ft (7.6 m)	100007551
50 ft (15.2 m)	100007552
Custom to 50 ft (15.2 m)	100007553
Cable for Capacitance Manometer, Type 122B/626A	
10 ft (3.0 m)	100007555
25 ft (7.6 m)	100007556
50 ft (15.2 m)	100007557
Custom to 50 ft (15.2 m)	100007558
Cable for Cold Cathode Sensor Series 421	
10 ft (3.0 m)	100006171
25 ft (7.6 m)	100006172
50 ft (15.2 m)	100006173
100 ft (30.5 m)	100006174
Custom to 300 ft (91.4 m)	100006175
Series 423 I-MAG®	
2 ft (0.6 m)	100002505
10 ft (3.0 m)	100007873
25 ft (7.6 m)	100007874
50 ft (15.2 m)	100002395
Custom to 300 ft (91.4 m)	100008759
Cable for 317 Convection Pirani & 345 Pirani Sensor	
10 ft (3.0 m)	103170006SH
25 ft (7.6 m)	103170007SH
50 ft (15.2 m)	103170008SH
100 ft (30.5 m)	103170017SH
Custom to 500 ft (152.4 m)	103170009SH
Cable for 315 Pirani Sensor	
10 ft (3.0 m)	103150006
25 ft (7.6 m)	103150007
50 ft (15.2 m)	103150008
100 ft (30.5 m)	103150017
Custom to 500 ft (152.4 m)	103150009
Cable for Thermocouple Sensor	
10 ft (3.0 m)	100007448
20 ft (6.1 m)	100007449
Custom to 25 ft (7.6 m)	100007450
Capacitance Manometer (consult HPS Series 937A System brochure)	
IgniTorr™ Cold Cathode Starting Device (for use with CF flange only)	
120V	100006850
220V	100007090

Internal Rebuild Kit	
Series 421	100006734
Spanner Wrench	100005279
Series 423 I-MAG®	100002353
Module, Communications	
RS-232/RS-485	100009183
Module, Sensor	
Cold Cathode	100009428
Dual Pirani	100005961
Single Pirani	100007033
Dual Capacitance Manometer	100007321
Single Capacitance Manometer	100006037
Dual Thermocouple	100006034
Single Thermocouple	100007034
Dual Convection	100007943
Single Convection	100007035
Panel Mounting Kit, Half-rack	100005651
Power Cord, 115 VAC	103150001
Sensor, Cold Cathode	
Series 421	
KF 25	104210004
KF 40	104210001
2¾" CF	104210002
1" tube	104210003
8 VCR®-F (½")	104210005
Series 423 I-MAG®	
KF 25	104230004
KF 40	104230001
2¾" CF	104230002
1" tube	104230003
Sensor, Convection Pirani	
KF 16	103170010
1/8" NPT-M	103170011
with ½" Compression Seal Option	
8 VCR®-F (½")	103170012
4 VCR®-F (¼")	103170029
1⅓" CF (non-rotatable)	103170013
2¾" CF (non-rotatable)	103170014
Ø 15 mm x 30 mm Tubing	103170016
Ø 18 mm x 30 mm Tubing	103170018
Sensor, Convection Pirani, Shielded	
KF 16	103170010SH
1/8" NPT-M	103170011SH
with ½" Compression Seal Option	
8 VCR®-F (½")	103170012SH
4 VCR®-F (¼")	103170029SH
1⅓" CF (non-rotatable)	103170013SH
2¾" CF (non-rotatable)	103170014SH
Ø 15 mm x 30 mm Tubing	103170016SH
Ø 18 mm x 30 mm Tubing	103170018SH

Sensor, Pirani (315 & 345)

KF 16	103150010
1/8" NPT-M	103150011
with 1/2" Compression Seal Option	
8 VCR®-F (1/2")	103150012
1 1/3" CF (non-rotatable)	103150013
2 3/4" CF (non-rotatable)	103150014
Ø 15 mm x 30 mm Tubing	103150016
Ø 18 mm x 30 mm Tubing	103150018

Sensor, Thermocouple

1/8" NPT-M	100006763
------------	-----------

HPS™ Products Series 937A Combination

100009273

Vacuum Sensor System User's Manual

Please call the HPS™ Products Customer Service Department of MKS Vacuum Products Group at 1-303-449-9861 or 1-800-345-1967 to order any of these parts or to receive catalogs for other MKS products.

Product Warranty

Extent of the Warranty

MKS Instruments, Inc., Vacuum Products Group (MKS), warrants the HPS™ Products Series 937A High Vacuum, Multi-Sensor System and its accessories to be free from defects in materials and workmanship for one (1) year from the date of shipment by MKS or authorized representative to the original purchaser (PURCHASER). Any product or parts of the product repaired or replaced by MKS under this warranty are warranted only for the remaining unexpired part of its one (1) year original warranty period. After expiration of the applicable warranty period, the PURCHASER shall be charged MKS' current prices for parts and labor, plus any transportation for any repairs or replacement. **ALL EXPRESS AND IMPLIED WARRANTIES, INCLUDING THE IMPLIED WARRANTIES OF MERCHANTABILITY AND FITNESS FOR A PARTICULAR PURPOSE, ARE LIMITED TO THE WARRANTY PERIOD. NO WARRANTIES, EXPRESS OR IMPLIED, WILL APPLY AFTER THIS PERIOD.**

Warranty Service

The obligations of MKS under this warranty shall be at its option: (1) to repair, replace, or adjust the product so that it meets applicable product specifications published by MKS or (2) to refund the purchase price.

What Is Not Covered

The product is subject to above terms only if located in the country of the seller from whom the product was purchased. The above warranties do not apply to:

- I. Damages or malfunctions due to failure to provide reasonable and necessary maintenance in accordance with MKS operating instructions.
- II. Damages or malfunctions due to chemical or electrolytic influences or use of the product in working environments outside the specification.
- III. Fuses and all expendable items which by their nature or limited lifetime may not function for a year. If such items fail to give reasonable service for a reasonable period of time within the warranty period of the product; they will, at the option of MKS, be repaired or replaced.
- IV. Defects or damages caused by modifications and repairs effected by the original PURCHASER or third parties not authorized in the manual.

Condition of Returned Products

MKS will not accept for repair, replacement, or credit any product which is asserted to be defective by the PURCHASER, or any product for which paid or unpaid service is desired, if the product is contaminated with potentially corrosive, reactive, harmful, or radioactive materials, gases, or chemicals.

When products are used with toxic chemicals, or in an atmosphere that is dangerous to the health of humans, or is environmentally unsafe, it is the responsibility of the PURCHASER to have the product cleaned by an independent agency skilled and approved in the handling and cleaning of contaminated materials before the product will be accepted by MKS for repair and/or replacement.

In the course of implementing this policy, MKS Customer Service Personnel may inquire of the PURCHASER whether the product has been contaminated with or exposed to potentially corrosive, reactive, harmful, or radioactive materials, gases, or chemicals when the PURCHASER requests a return authorization. Notwithstanding such inquiries, it is the responsibility of the PURCHASER to ensure that no products are returned to MKS which have been contaminated in the aforementioned manner.

Other Rights and Remedies

- I. These remedies are exclusive. HPS SHALL NOT BE LIABLE FOR CONSEQUENTIAL DAMAGES, FOR ANTICIPATED OR LOST PROFITS, INCIDENTAL DAMAGES OR LOSS OF TIME, OR OTHER LOSSES INCURRED BY THE PURCHASER OR BY ANY THIRD PARTY IN CONNECTION WITH THE PRODUCT COVERED BY THIS WARRANTY, OR OTHERWISE. Some states do not allow exclusion or limitation of incidental or consequential damage or do not allow the limitation on how long an implied warranty lasts. If such laws apply, the limitations or exclusions expressed herein may not apply to PURCHASER.
- II. Unless otherwise explicitly agreed in writing, it is understood that these are the only written warranties given by HPS. Any statements made by any persons, including representatives of MKS, which are inconsistent or in conflict with the terms of the warranty shall not be binding on MKS unless reduced to writing and approved by an authorized officer of MKS.
- III. This warranty gives PURCHASER specific legal rights, and PURCHASER may also have other rights which vary from state to state.
- IV. For MKS products sold outside of the U.S., contact your MKS representative for warranty information and service.

Warranty Performance

To obtain warranty satisfaction, contact the following: MKS Instruments, Inc., Vacuum Products Group, 5330 Sterling Drive, Boulder, CO 80301, USA, at phone number (303) 449-9861. You may be required to present proof of original purchase.

Notes

Appendix A: Installing a Series 937A Sensor



The Series 937A Controller must be switched off before connecting or disconnecting a cable from the sensor or Controller.

Cold Cathode Sensors

General

In a cold cathode sensor, gas molecules are ionized by a high voltage discharge of electrons. Sensitivity is enhanced by a magnetic field. Cold cathode sensors are rugged sensors without filaments to break or burn out.

The MKS inverted magnetron design includes an isolated collector, making low pressure measurement less susceptible to contamination and allowing a wider range of pressure measurement. The MKS IgniTorr™, an optional cold cathode starting device initiates the ionization process in cold cathode sensors, assuring UHV pressure readings in seconds (see **Spare Parts and Accessories**, p. 71).

Locating a Cold Cathode Sensor

Locate a cold cathode sensor where it can measure process chamber or manifold pressure. Install it away from pumps, gas sources, and strong magnetic fields to give the most representative values.

Locate and orient a cold cathode sensor where contamination is least likely. If it is installed directly above a diffusion pump, for example, oil vapor could contaminate the cathode, anode, or other vacuum exposed components, causing the calibration to shift.

Orienting a Cold Cathode Sensor

A cold cathode sensor can be installed with the body set in any direction. Operating position does not affect accuracy.

Installing it with the vacuum port facing down is preferable as this helps prevent contaminants from falling into the sensor.

Managing Contamination in a Cold Cathode Sensor

Do not operate at pressures above 10^{-3} Torr for extended periods as this will increase the likelihood of contamination.

If pressure readings appear to be erratic, the Sensor tube may be contaminated. Inspect it visually. If contamination is visible, you should replace the internal components with an Internal Rebuild Kit (see **Accessories**, p.67).

Depending on the degree of contamination and application, the internal parts may be cleaned (see **Cleaning the I-MAG Sensor**, page A.3).

Testing a Cold Cathode Sensor

HPS cold cathode sensors contain the anode and cathode (collector) electrodes. Test the sensor with an ohmmeter. There should be no shorts between the electrodes or from the electrodes to the sensor body.

Series 423 I-MAG® Cold Cathode Sensor

Connecting the I-MAG Sensor

Mount the Sensor to a grounded vacuum system.

If the I-MAG Sensor has a CF flange, remove the magnet first to allow clearance for bolt installation. When replacing the magnet, note that it is keyed to the sensor body to protect the feedthrough pins from damage. The pins should be straight and centered.

For grounding, use a conductive, all-metal clamp to mount a KF 25 or KF 40 flanged sensor body.

Connect the cable to the Sensor and to the Series 937A Controller before turning on your system. Tighten the thumb screw on top of the cable to make sure it is securely in place.



For the following section, please refer to the figure shown on page A.4.

Disassembling the I-MAG Sensor

Tools required: clean tweezers; clean smooth-jaw, needle-nose pliers

- 1 Turn Power off to the Series 937A Controller.
- 2 Loosen the thumb screw on top of the sensor cable and remove the cable.
- 3 Loosen the two *flat head screws* .

-
- 4 Remove the *magnet* ⑭ .
 - 5 Using the smooth-jaw, needle-nose pliers, firmly grab the *compression spring* ① at the tip closest to the flange.
 - 6 Pull on the *compression spring* while rotating to free it from the formed groove of the *sensor body* ⑦ . Continue to pull until the *compression spring* is completely free.
 - 7 With the vacuum port facing up, carefully remove the remaining components (② through ⑥) from the *sensor body*.



Do not bend the anode ⑧ or the leaf spring ⑨ on the ion current feedthrough pin ⑬ when assembling or disassembling the Sensor.

Cleaning the I-MAG Sensor

Depending on the degree of contamination and application of the Sensor, the internal parts may be cleaned — either ultrasonically, with mild abrasives, or chemically.



Do not touch any vacuum exposed part after cleaning unless wearing gloves.

Ultrasonically clean using high quality detergents compatible with aluminum such as ALCONOX®.

Scrub with a mild abrasive to remove most contamination. Scotch-Brite™ or fine emery cloth may be effective. Rinse with alcohol.

Clean aluminum and ceramic parts chemically in a wash (not recommended for semiconductor processing), such as a 5 to 20% sodium hydroxide solution, at room temperature (20°C) for one minute. Follow with a preliminary rinse of deionized water. Remove smut (the black residue left on aluminum parts) in a 50 to 70% nitric acid dip for about 5 minutes.



Chemical cleaning should not be used to clean the *anode*; mild abrasives or ultrasonic cleaning are acceptable.



Do not damage the *leaf spring* ⑨ while cleaning the Sensor.

Each of the above cleaning methods should be followed with multiple rinses of deionized water.

Dry all internal components and the *sensor body* ⑦ in a clean oven set at 150°C. The two *ceramic spacers*, ② and ⑤ , are slightly porous and will require longer drying time in the oven to drive off the absorbed water.

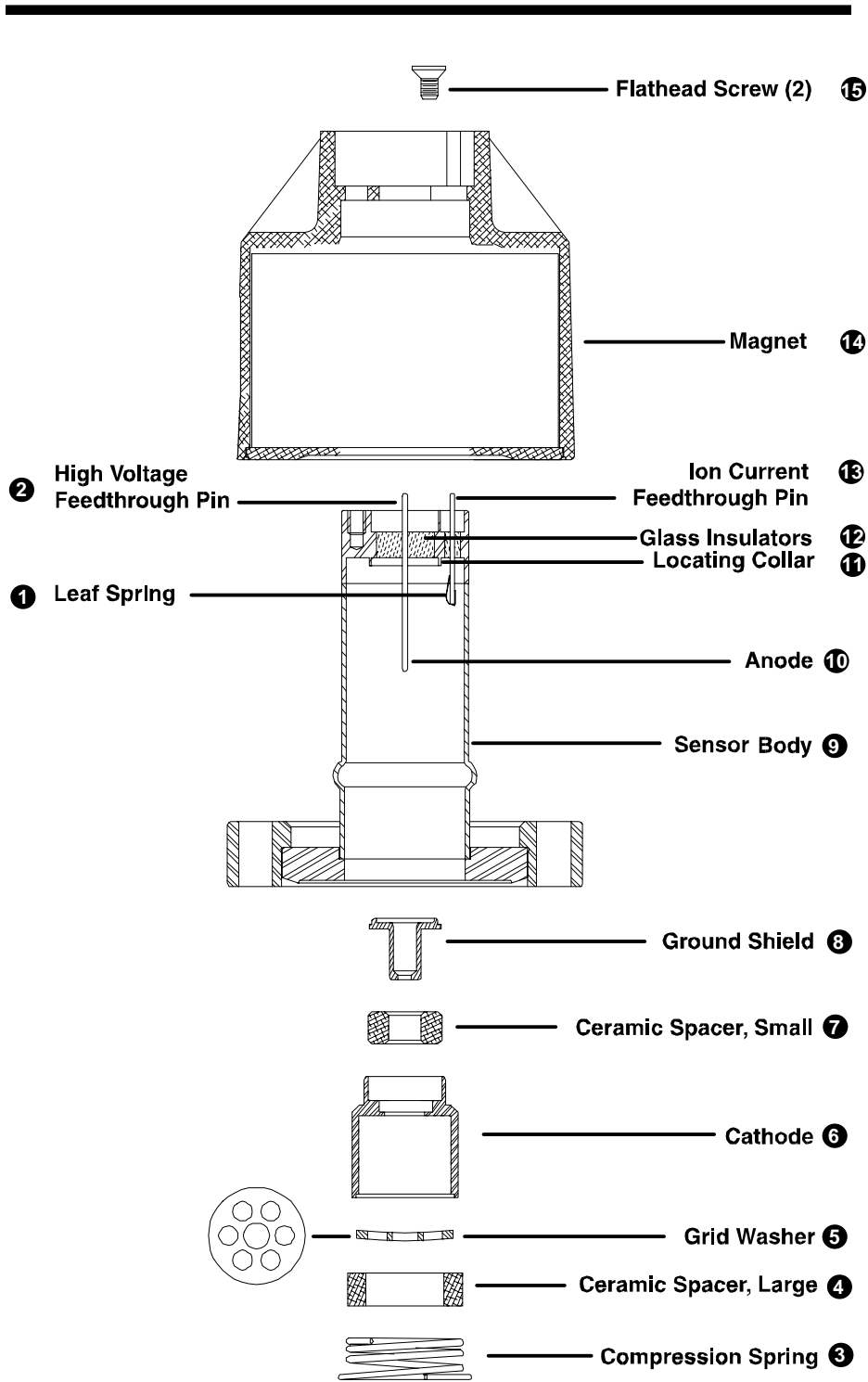

Series 423 I-MAG[®] Sensor, exploded view

Assembling the I-MAG Sensor

 **Wear gloves and assemble with clean tools.**

- 1 Roll the *sensor body* on a flat surface and, looking down the port, check the *anode* ③ for any radial runout motion. It should be straight and centered with the *sensor body* ⑦ for proper operation.
- 2 Install the *ground shield* ⑥ using tweezers. Make sure that the *ground shield* drops into the *locating collar* ⑪ .
- 3 Slide the *small ceramic spacer* ⑤ over the small end of the *ground shield* ⑥ .
- 4 Check that the *leaf spring* ⑨ will contact the base of the *cathode* ④ as shown to the right. If not, remove the *small ceramic spacer* and the *ground shield*, and gently bend the *leaf spring* towards the *anode* ③ and then replace the *ground shield* and *ceramic spacer*.
- 5 Slide the *cathode* ④, the *grid washer* ③, and the *large ceramic spacer* ② into place. The *grid washer* has a concave shape. Refer to the figures to see its installation orientation.
- 6 Insert the small end of the *compression spring* ① into the *sensor body* ⑦ .
- 7 Using your thumbs, push the larger end of the spring into the *sensor body* until it is contained within the tube's inside diameter.
- 8 Using the smooth-jaw, needle-nose pliers, work the *compression spring* down into the *sensor body* until it is fully seated in the formed groove.
- 9 Inspect the *ground shield* ⑥ and the *grid washer* ③ to verify they are centered with respect to the *anode* ③ .
- 10 If adjustment is needed, gently reposition the grid washer/cathode assembly, taking care not to scratch the *grid washer*.

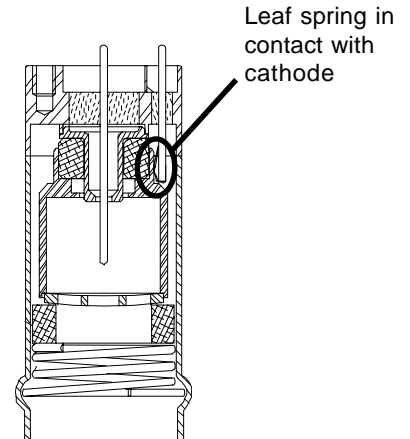

We suggest you measure the resistance between the *ion current feedthrough pin* ⑬ and the *grid washer* ③ to verify that the *leaf spring* ⑨ is in contact with the *cathode* ④ . The measurement should indicate a short circuit between them. There should be an open circuit between the *ion current feedthrough pin* ⑬ and both the *high voltage feedthrough pin* ⑩ and *sensor body* ⑦ .

The I-MAG Sensor is ready for installation. If it is not immediately installed, cover the flange with clean, vacuum grade aluminum foil and cap with a flange protector.

Preparing the Sensor for Bakeout

To prepare the sensor for bakeout up to 400°C, remove the sensor cable and magnet assembly as described in "Disassembling the I-MAG sensor".

Series 421 Cold Cathode Sensor

Connecting the Series 421 Sensor

The Series 421 Cold Cathode Sensor and Series 937A Controller are connected to one another using coaxial cables with SHV and SMA connectors as shown below.

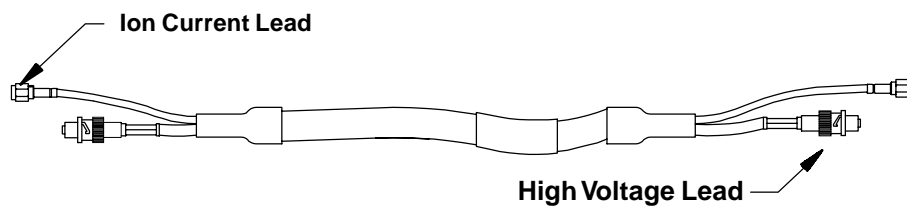

Series 421 Cold Cathode Sensor cable

Connect the SHV and SMA connectors to their respective connectors on the rear panel of the Controller – H.V. (SHV connector) and Ion Current (SMA connector).

Where stress might be applied to the cable, use separate strain relief to avoid damage to the sensor, cable, or the Controller. Cables are available from the factory in standard lengths of 10, 25, 50, and 100 feet and in custom lengths up to 300 ft.

Some applications may require the use of special cables, such as when the connection must be routed through restrictive barriers or through a conduit. Custom cables may be fabricated for these situations. Use SHV and SMA connectors for all applications.

Disassembling the Series 421 Sensor



For the following section, please refer to the figure shown on page A.7.

The Sensor breaks down into three subassemblies – the backshell, the internal, and the body subassemblies. Only the internal and body subassemblies are exposed to vacuum.

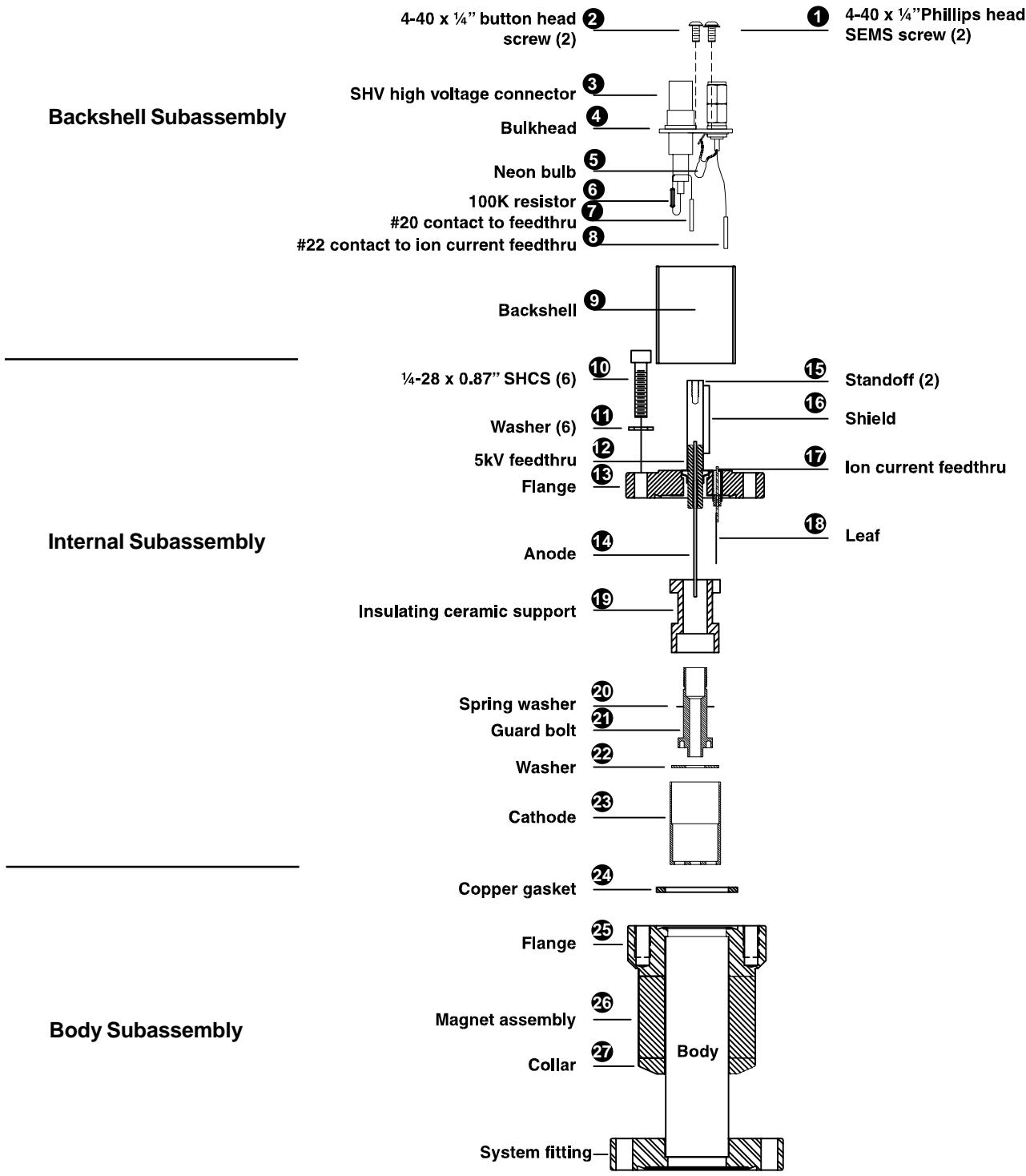

Series 421 Cold Cathode Sensor, exploded view of backshell, internal, and body subassemblies

To disassemble the Sensor, remove the backshell subassembly as follows (Steps 1 through 4 are not necessary when replacing internal parts):

- 1 Remove the two 4-40 x ¼" Phillips head SEMS screws ② and slide the backshell ⑨ off the sensor.
- 2 Remove the two 4-40 x ¼" button head screws ①.
- 3 Use needle nose pliers to pull the #22 contact ⑧ carefully off of the ion current feedthrough ⑰.
- 4 Pull the #20 contact ⑦ off of the 5kV feedthrough taking the entire bulkhead ④ with it (do not remove the SHV and SMA connectors from the bulkhead).
- 5 Remove the six ¼-28 x 0.875" socket head cap screws ⑩ and pull the back flange ⑬ free. Note that these screws are silver-plated for lubricity and should be used only once. They may be relubricated with a dry lubricant such as molybdenum disulfide, though new silver-plated screws are recommended. The copper gasket ⑳ must be replaced with a standard 2⅛" CF flange gasket.

The cathode and anode assemblies are attached to the flange. Here disassembly generally proceeds from bottom to top of the internal assembly drawing.

- 6 To remove the cathode ㉓, release the two integral, spring-loaded ears hooked over the shoulder of the ceramic insulating support ⑲.
- 7 Gently pull up on the ear until it just clears the outer diameter of the insulating support.



the position of the small Elgiloy® leaf ⑮ used to connect the ion current feedthrough ⑰ to the cathode. Rotational position of the cathode with respect to the leaf is not critical, but take care to not bend the leaf.

- 8 Slide the cathode ㉓ and washer ㉒ off the insulating support.
- 9 The insulating support is captured by the guard bolt ㉑. Remove with a spanner wrench and unscrew the guard bolt from the flange ⑬.



the presence of the small curved spring washer ㉐ under the head of the guard bolt. The spring washer holds the insulating support tight, preloads the guard bolt to resist unscrewing due to possible vibration, and provides compliance for differential thermal expansion during bakeout.

Cleaning the Series 421 Sensor

The procedure for cleaning the internal parts of the 421 sensor is the same as that used for the Series 423 I-MAG Cold Cathode Sensor (see p. A.3).

Assembling the Series 421 Sensor

To reassemble, reverse the order used during disassembly. Note the following tightening procedure of the *guard bolt*. The *bolt* has a $3/8$ "-40 thread which is delicate.

- 1 Finger tighten the *guard bolt* to compress the *spring washer* and then back off one turn. Do not overtighten as this will remove all compliance from the *spring washer* and possibly damage the aluminum $3/8$ "-40 thread.
- 2 Verify that the *anode* 14 is well-centered within the bore of the *guard bolt*.
- 3 If it is off center, carefully bend it back into position and continue with the assembly.

Preparing the Sensor for Bakeout

To prepare the Sensor for bakeout up to 125°C, remove the high voltage and ion current cables only.

To prepare the Sensor for bakeout up to 250°C, also remove the backshell subassembly shown on page A.7. Follow steps 1 through 4 of **Disassembling the Series 421 Sensor** on page A.8.

Pirani Sensors

General

Two types of Pirani sensor can be used with the Series 937A Controller –standard and convection. In both, measurement is based on thermal conductivity of the gas. The sensors contain a filament, maintained at a constant temperature. Heat loss from the wire depends on the amount of gas present.

The standard Pirani sensor will read continuously from 5×10^{-4} to 100 Torr, with lower resolution up to atmosphere.

The Convection Pirani sensor design enhances heat transfer through convection at higher pressures. This sensor will read continuously with full resolution from 1.0×10^{-3} to 1000 Torr.

Locating a Pirani Sensor

Locate a Pirani sensor where it can measure chamber or manifold pressure. Installing a sensor away from pumps and gas sources gives the most representative values. Place a sensor where vibration is minimal.

Preventing Contamination in a Pirani Sensor

Locate and orient a Pirani sensor to avoid contamination which might affect the tube's element. For example, if a sensor is installed directly above a roughing pump in the system, oil vapor could contaminate the tube's filament wire and cause the calibration to shift.

Install a Pirani sensor with the vacuum port facing downward whenever possible to prevent particulates and liquids falling or flowing into it. Using a screen or porous filter at the port is helpful. Try an HPS™ Product seal and centering ring assembly with a screen (see **Accessories**, p.67).

Series 315/345 Pirani Sensor

Orienting the Series 315/345 Pirani Sensor

Operating position has no effect on accuracy. The Pirani sensor was designed to minimize the effects of convection. In a standard Pirani system, the output of the sensor changes very little between the horizontal and vertical position.

The Series 315/345 Pirani sensor exhibits slight convection characteristics near atmosphere. Therefore, the best accuracy can be achieved above 30 Torr by calibrating the sensor oriented vertically with the port facing down. The Pirani sensor can be calibrated at any pressure between 600 and 1000 Torr.

Connecting the Series 315/345 Sensor

To fit a KF 16 port to a KF 10 port, use an HPS adaptive centering ring (HPS™ PN 100315821)

To install the Sensor with a 1/8" NPT, *do not* use the case for tightening. Use the 9/16" hex flats on the sensor's vacuum tubing for tightening. Wrap about two turns of Teflon® tape on the threads of the Sensor in the direction of the threading to ensure a leak-free seal.



Do not use a compression mount (quick connect) to attach the Sensor to a system in positive pressure applications.

Positive pressures might blow the Sensor out of a compression fitting, damaging equipment and possibly injuring personnel.



A solid electrical connection between the Sensor and the grounded vacuum system must be provided to shield the tube element from external radiation sources.

In applications where the system may be exposed to large voltage fluctuations, a centering ring with a screen should be installed, and the screen and tubing then grounded. The clamp must be tightened properly so the flange contacts the centering ring.

The sensor cable is connected to the Controller with the 9-pin "D" connector as shown above. This connector is equipped with integral strain relief. Screw the strain reliefs into the mating standoffs on the rear of the Controller for good contact and to avoid excess stress on the connectors.

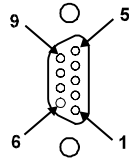

Pin	Description
1,6	bridge drive, +
5,9	bridge drive, -
2	chassis ground
3	signal +
4	signal -
7	bridge sensor leg
8	bridge reference leg

9-pin, "D" connector on Pirani sensor module

The Series 315 Pirani Sensor is connected to the module with a multiconductor shielded cable. It has a standard round octal socket on one end with an integrated polarizing tab. If excess stress is applied to the cable, use separate strain relief to prevent damage to the sensor, cable or the Controller. Cables are available in standard lengths of 10, 25, 50, and 100 feet and in custom lengths up to 500 feet.

SENSOR

CONTROLLER

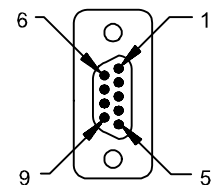
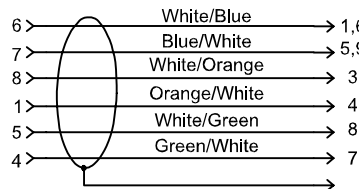
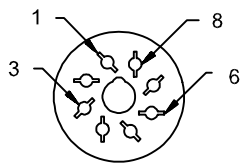

Female, 8-pin octal connector

Male, 9-pin "D" connector

Making a 315 Pirani cable

The series 345 Pirani Sensor is connected to the controller using the same cable as the Series 317 Convection Pirani. Refer to **Connecting the Series 317 Sensor** on page A.14 for information about this cable.

Some applications may require the use of special cables, such as when the connection must be routed through restrictive barriers or through a conduit. Custom cables may be fabricated for these situations using the information provided in the figure. The maximum length of the sensor cable is 500 feet. Use a "D" connector with integral strain relief for all applications.

Cleaning the Series 315/345 Sensor

Roughing pump oils and other fluids condensing or decomposing on the heated filament can contaminate the Sensor. This changes the emissivity of the filament, which in turn can cause the calibration to change, especially at low pressure.



It is not advisable to clean the Sensor. Trying to clean it may either deform or break the filament. The deformed filament would then cause additional error from a shift in the Sensor's output.

Replace the Sensor if it becomes contaminated (see **Spare Parts and Accessories**, p.67).

Testing the Series 315/345 Sensor



This test is for function only. Slight Sensor damage by contamination or rough handling can affect calibration, but the tube may still be functional.

The most common cause of Sensor failure is a broken filament (checked from pin 4 to pin 6) due to improper handling.

Test the Sensor with an ohmmeter with less than 5 mA of current. The resistance readings of a normal Series 315/345 Sensor measured at atmospheric pressure and at room temperature (20°C) are shown here.

315 Octal Pin Numbers	345 D-sub Pin Numbers	Resistance (W)
1 to 4	4 to 7	39
1 to 5	4 to 8	114
4 to 6	6 to 7	31
5 to 6	6 to 8	114
6 to 7	5 to 6	62
7 to 8	3 to 5	345

Series 317 Convection Pirani Sensor

Orienting the Series 317 Sensor



When measuring pressures greater than 1 Torr, the Series 317 Sensor must be mounted with its axis horizontal.

Measurements below 1 Torr are unaffected by position, but readings will be incorrect at higher pressures. These readings could result in under- or over-pressure, damaging equipment or injuring personnel.

Mount the Sensor with the vacuum port facing downward to reduce particulates and liquids falling or flowing into it. The Sensor has been calibrated in this position.

Connecting the Series 317 Sensor

To fit a KF 16 port to a KF 10 port, use an HPS™ adaptive centering ring (HPS™ PN 100315821)

To install the Sensor with a 1/8" NPT, *do not* use the case for tightening. The Sensor's vacuum tubing has 9/16" hex flats for tightening. Wrap about two turns of Teflon® tape on the threads of the Sensor in the direction of the threading to ensure a leak-free seal. Positive pressures might blow the Sensor out of a compression fitting, damaging equipment and possibly injuring personnel.



Do not use a compression mount (quick connect) to attach the Sensor to a system in positive pressure applications.

Positive pressures might blow the sensor out of the compression fitting, damaging equipment and possibly injuring personnel.



A solid electrical connection between the Sensor and the grounded vacuum system must be provided to shield the tube element from external radiation sources.

In applications where the system may be exposed to large voltage fluctuations, a centering ring with a screen should be installed, and the screen and tubing then grounded. The clamp must be tightened properly so the flange contacts the centering ring.

A Convection Pirani sensor is connected to the Controller's convection sensor module with a multiconductor shielded cable. It has a 9-pin "D" connector at each end as shown here. This connector is equipped with integral strain relief. Screw the strain reliefs into the mating standoffs on the rear of the Controller for good contact and to avoid excess stress on the connectors.

If excess stress is applied to the cable, use separate strain relief to prevent damage to the sensor, cable or the Controller. Cables are available from HPS™ in standard lengths of 10, 25, 50, and 100 feet and in custom lengths up to 500 feet.

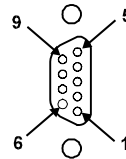

Pin	Description
1,6	bridge drive, +
5,9	bridge drive, -
2	chassis ground
3	signal +
4	signal -
7	bridge sensor leg
8	bridge reference leg

9-pin, "D" connector on Series 317 Convection Pirani Sensor module

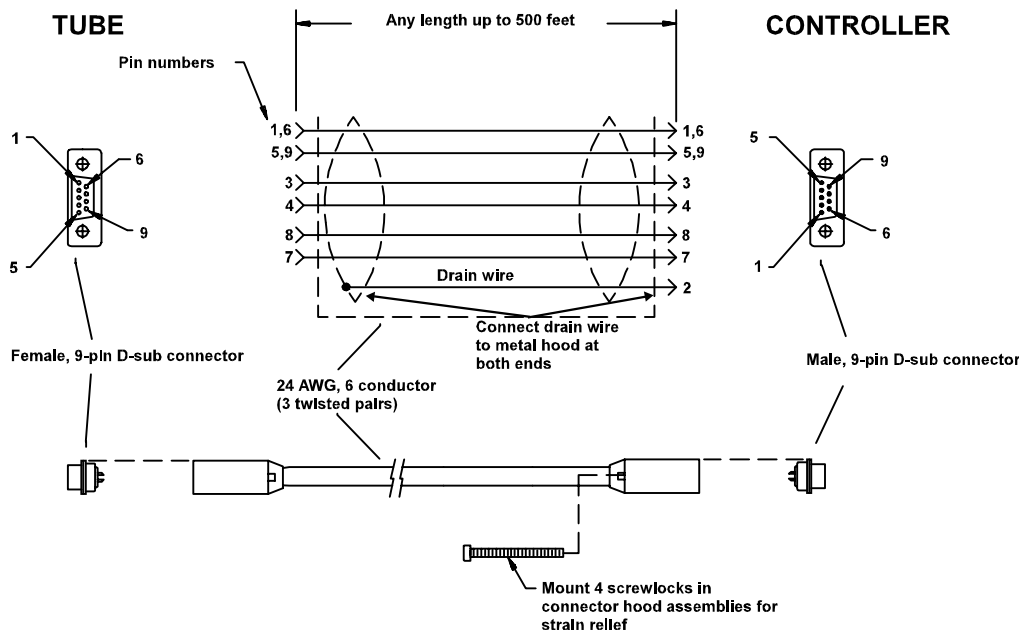

Some applications may require the use of special cables, such as where the connection must be routed through restrictive barriers or through a conduit. Custom cables may be fabricated for these situations using the information provided in the figure shown on the following page. The maximum length of the sensor cable is 500 feet. Use a "D" connector with integral strain relief for all applications.

Cleaning the Series 317 Sensor

Roughing pump oils and other fluids condensing or decomposing on the heated filament can contaminate the Sensor. This changes the emissivity of the filament, which in turn can cause the calibration to change, especially at low pressure.



It is not advisable to clean the Sensor. Trying to clean it may either deform or break the filament. The deformed filament would then cause additional error from a shift in the Sensor's output.

Replace the Sensor if it becomes contaminated (see **Spare Parts and Accessories**, page.67).

Testing the Series 317 Sensor

The most common cause of sensor failure is a broken filament. This might be caused by physical abuse or sudden venting of the sensor to atmosphere at the inlet port.

- 1 With a #1 Phillips head screwdriver, remove the two screws to separate the connector/electronics subassembly from the end of the Sensor as shown below.
- 2 Check the resistance on the Sensor's pins listed in the first column on the table below. Test the Sensor with an ohmmeter with less than 5 mA of current. The resistance readings of a normal Sensor measured at atmospheric pressure and at room temperature (20°C) are listed in the middle column. If the condition shown in the right column exists, the Sensor should be replaced.

Check	Resistance (Ω)	If
F1 to F2	20	Higher, filament is broken or burned out.
F1 to Sensor port F2 to Sensor port	$\geq 20 \times 10^6$	Lower, Sensor is damaged or contaminated.
TC1 to TC2	27	Higher, temperature compensation winding is broken.
TC1 to Sensor port TC2 to Sensor port	$\geq 20 \times 10^6$	Lower, temperature compensation winding is

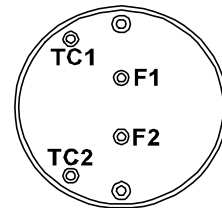

Sensor Tube

Preparing the 317 Sensor for Bakeout

Remove the cable from the Sensor. Use a #1 Phillips head screwdriver to remove the two screws at the end of the connector/electronics subassembly to separate it from the Sensor. The standard Convection Pirani Sensor can be baked up to 150°C and the Shielded Convection Pirani Sensor can be baked up to 100°C.

Capacitance Manometer MKS Baratron®

General

Capacitance manometers supported by the Series 937A Controller include the MKS Baratron® Types 122A, 122B, 622, 626, and 722. Capacitance manometers measure pressure directly by measuring the deflection of a thin Inconel® diaphragm. Baratrons are widely known for their accuracy and reliability and are available in full scale ranges from 1 to 1000 Torr, each with a 3-decade range.

See an MKS Baratron instruction manual for complete information on using these capacitance manometers.

Installing the Baratron Capacitance Manometer

Although Types 122A and B Capacitance Manometers may be mounted in any position, placing them in a system with the Px port face down to allow any contamination to fall away from the pressure sensing diaphragm is recommended. Any standard vacuum fitting may be used (VCR®, compression, KF flange, etc.). The sensor port will easily carry the weight of the transducer.



Due to the failure of many users to follow the proper tightening procedures for single or double metal ferrule compression vacuum fittings and the resulting damage to the pressure sensor, MKS does not warrant this product when such fittings are used.

Connecting the Baratron™ Capacitance Manometer

A capacitance manometer head is connected to the module with a multiconductor shielded cable. The module has two female, 9-pin "D" connectors.

At the sensor head, the 10-foot, shielded cable has either a female, 15-pin "D" connector or wire pigtails, depending on the style of the sensor head.

A cable may be fabricated using the information shown below. A shielded cable is recommended, especially if the transducer's environment contains high EMI/RFI noise.

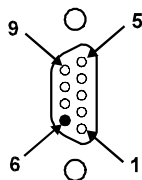

Pin	Description
1	-15 V
5	+15 V
6	chassis ground
7	signal -
8	signal +
9	±15 V return

Keyed "D" connector for capacitance manometer

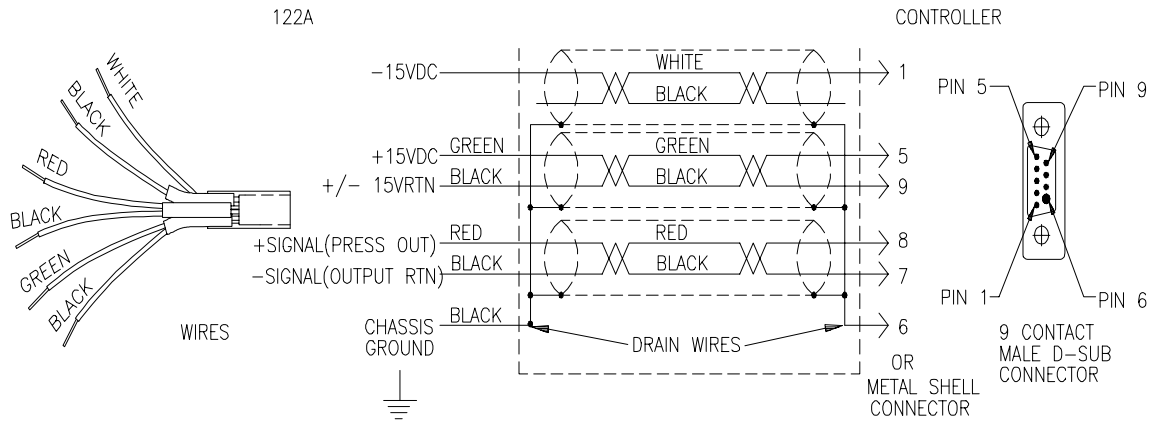

Baratron Type 622A shielded cable with pigtail wires

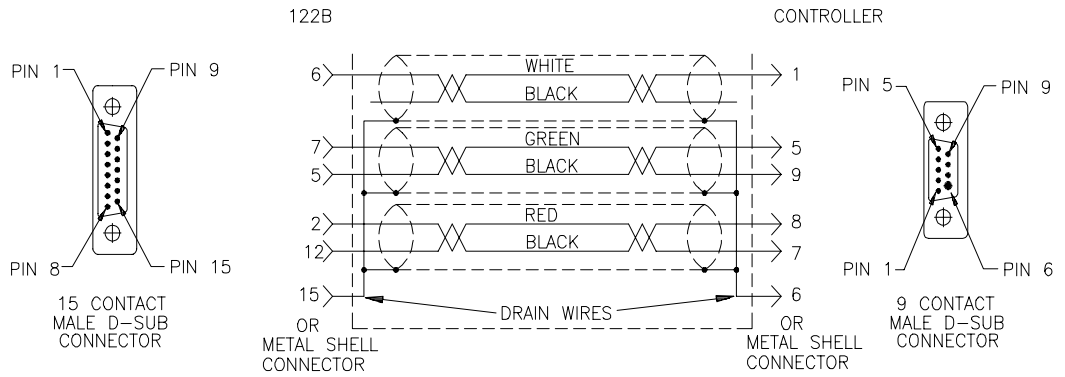

Baratron Type 626A shielded cable with 15-pin "D" connector

Repairing the Baratron™ Capacitance Manometer

Repair by the user is *not* recommended since replacement or movement of PC board components may require complete calibration of the unit. Return to MKS for repair.

Thermocouple Sensor

Teledyne-Hastings DV-6M

General

Thermocouple sensors, like Pirani sensors, measure vacuum through thermal conductivity. A thermocouple is used to measure temperature of a heated wire. The temperature of the wire is directly related to the gas pressure. Thermocouple sensors measure pressure from 1.0×10^{-3} to 1 Torr. They are low in cost, but are limited in range and accuracy.

Orienting the DV-6M Sensor

If installed in an area where condensable vapors are present, mount with the open end face down to allow drainage.

Connecting the DV-6M Sensor

A thermocouple sensor is available with a $1/8$ " NPT-M or 0.410 compression fitting. To install the Sensor with a $1/8$ " NPT, *do not* use the case for tightening. The Sensor's vacuum tubing has $9/16$ " hex flats for tightening. Wrap about two turns of Teflon[®] tape on the threads of the Sensor in the direction of the threading to ensure a leak-free seal.



Do not use a compression mount (quick connect) to attach the Sensor to a system in positive pressure applications.

Positive pressures might blow the Sensor out of a compression fitting, damaging equipment and possibly injuring personnel.



A solid electrical connection between the Sensor and the grounded vacuum system must be provided to shield the tube element from external radiation sources.

The thermocouple sensor module has two female, 9-pin "D" connectors. A thermocouple sensor is connected to the module with a multiconductor shielded cable.

At the sensor, the cable has a female, 8-pin octal connector. Cables may be fabricated using the information shown here (maximum length 25 ft).

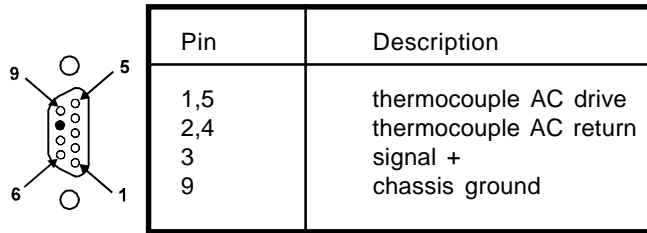

Keyed "D" connector for thermocouple

DV-6M SENSOR

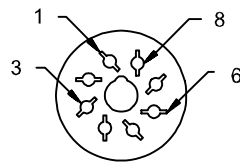

Female, 8-pin octal connector

CONTROLLER

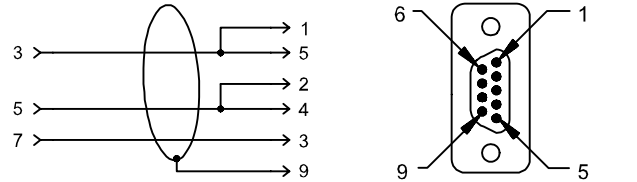

Male, 9-pin "D" connector

DV-6M thermocouple sensor shielded cable with 9-pin "D" connector

Cleaning the DV-6M Sensor

Roughing pump oils and other fluids condensing or decomposing on the heated filament can contaminate the Sensor. This changes the emissivity of the filament, which in turn can cause the calibration to change, especially at low pressure.



It is not advisable to clean the Sensor. Trying to clean it may either deform or break the filament. The deformed filament would then cause additional error from a shift in the Sensor's output.

Replace the sensor if it becomes contaminated (see Spare Parts and Accessories, page 67).

Appendix B: Leak Testing with the Series 937A

While the Series 937A Controller is not intended to replace mass spectrometer leak detectors, it offers a simple and inexpensive method for locating leaks in high vacuum systems. Under ideal conditions, a Pirani sensor can detect leaks as small as 1×10^{-4} Torr l/s and the cold cathode sensor can be used to detect leaks as small as 1×10^{-7} Torr l/s.

As with any leak testing, many factors can influence the sensitivity of the test. Described in greater detail below, these include chamber volume; system pressure; probe gas; type of vacuum pump; location of the Sensor, leak, and pump; and others such as pumping speed and system tube size.

- ◆ Reducing the search area by minimizing the **chamber volume** will increase the efficiency of the test.
- ◆ Sensitivity to gas leaks is also **pressure dependent**. In general, leak test sensitivity is greater for lower system pressures.
- ◆ The Pirani Sensor is sensitive to any leak **probe gas** lighter or heavier than the gas in the system. For optimal sensitivity, select a probe gas with the largest difference between its molecular weight and that of the system gas.

A gas different than the system gas entering through a leak will change the thermal energy transfer. Lighter gases increase thermal energy transfer while heavier gases reduce it. Helium or argon gas are suitable to probe a system pumping air or nitrogen.

Slowly and methodically probe with a small amount of gas. Flooding the leak with gas or moving the gas quickly past the leak can confuse the search since system time lags may be significant.



Since set points remain active in the Leak Test function, the probe gas may change the indicated pressure enough to switch the relay state. Disable any process control while probing the vacuum system.

- ◆ The **type of vacuum pump** used can also affect the accuracy of the leak test. For moderate size leaks, pump down the system with a high vacuum pump such as a diffusion or turbo pump if possible (ion and cryo pumps are not recommended). Leak testing can be done with a mechanical pump, however, they may cause cyclical variations in pressure with rotation of the vanes. This shows up as a large background noise signal possibly masking the leak signal.

-
- ◆ Place the pump away from the suspected **leak source** and place the sensor between the leak and the pump to reduce the sensor response time. Vacuum tubing between the suspected leak and the sensor should be as short and wide as possible to shorten the time required for the probe gas to reach the sensor.

If the above leak detection method fails to indicate the location of a leak, unexpected high pressures may be caused by a virtual leak, i.e., outgassing of a system component. You can locate outgassing parts, or “virtual leaks,” as well as true gas leaks using the *rate-of-pressure-rise* method below.

- 1 With the Controller on, pump down the system to a base pressure
- 2 Close a valve to isolate the pump.
- 3 Measure the rise of the pressure over a time interval. A very fast rise indicates a leak.
- 4 Repeat this procedure as often as necessary.

Appendix C: 937A Sensor Output vs. Pressure Curves



When using the graphs, remember that the pressure scale is always logarithmic, and the voltage scale is linear for all sensors except the capacitance manometer. Equal increments of distance along a logarithmic scale does not correspond to equal pressure or voltage changes.

Buffered Analog Output Cold Cathode (Series 421 and 423)

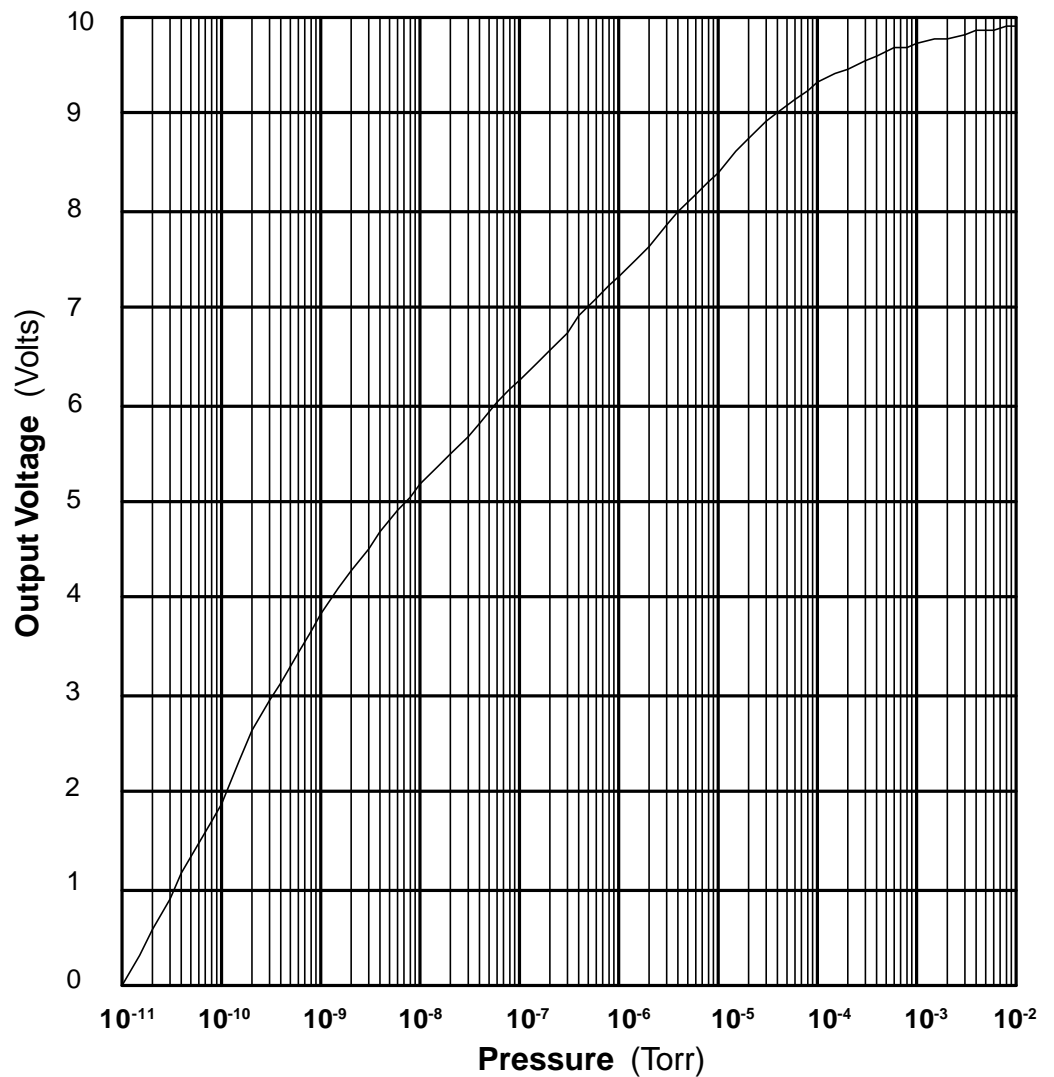

Buffered Analog Output Pirani (Series 315 and 345)

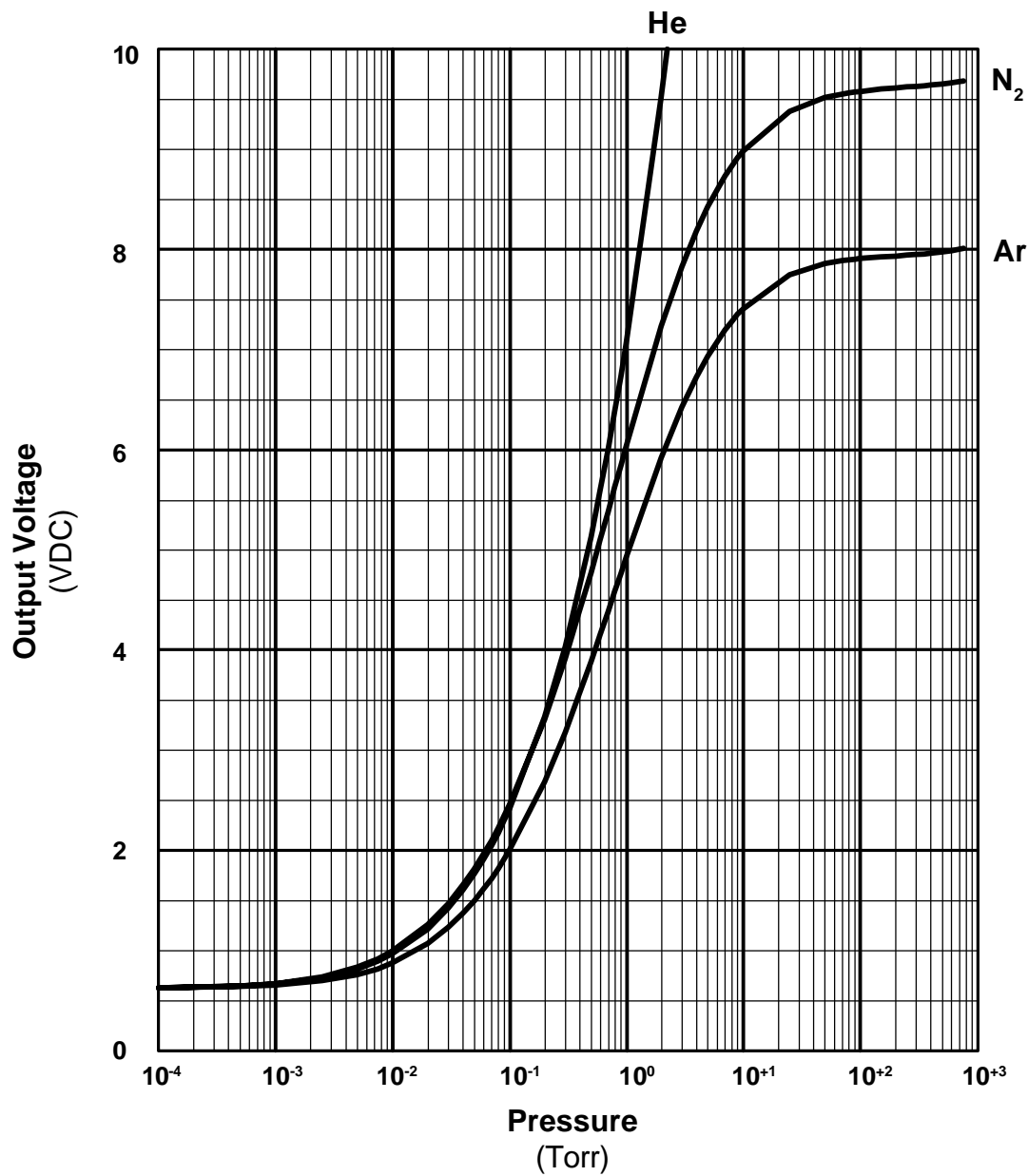

Buffered Analog Output Convection Pirani (Series 317)

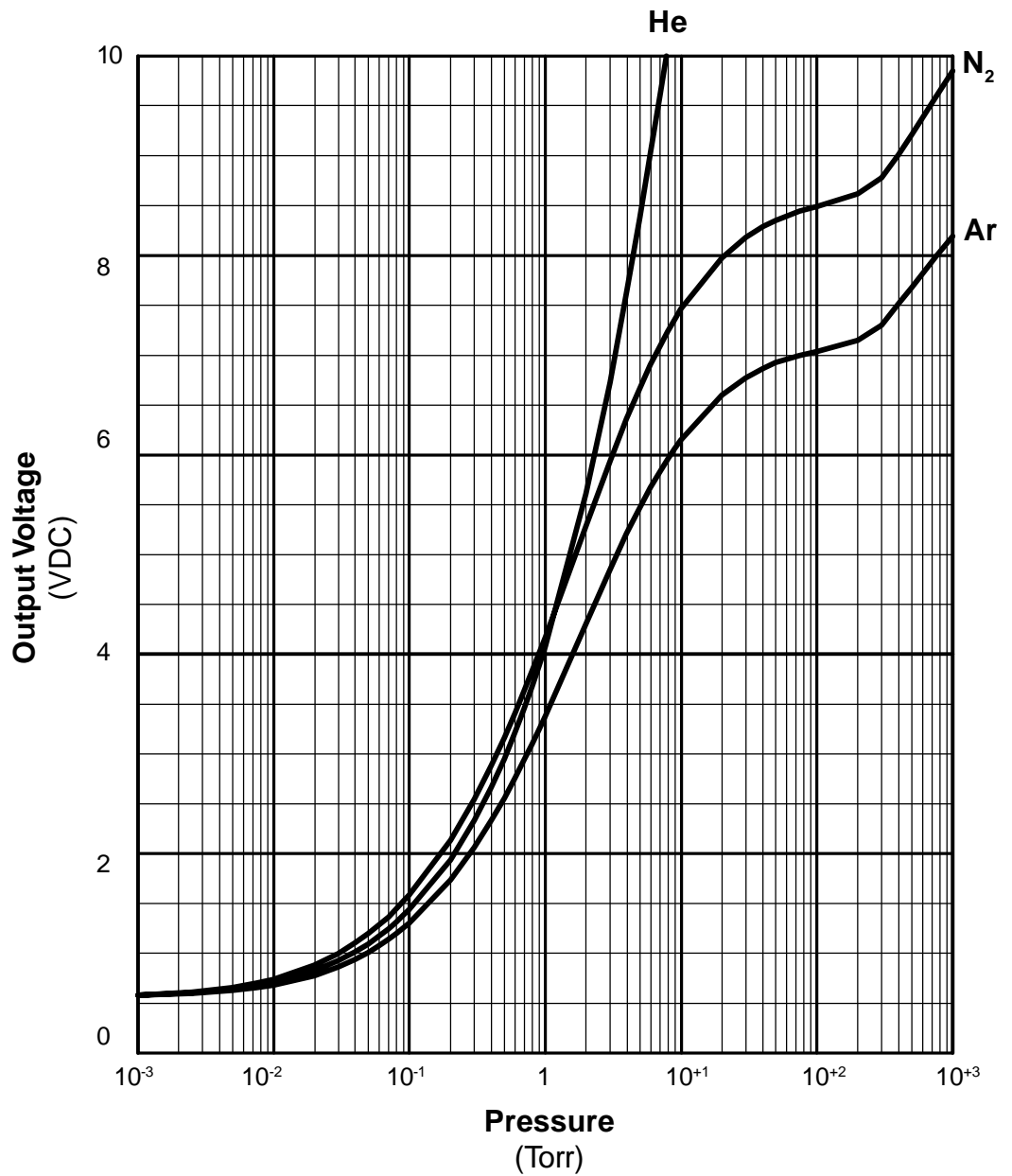

Buffered Analog Output Capacitance Manometer

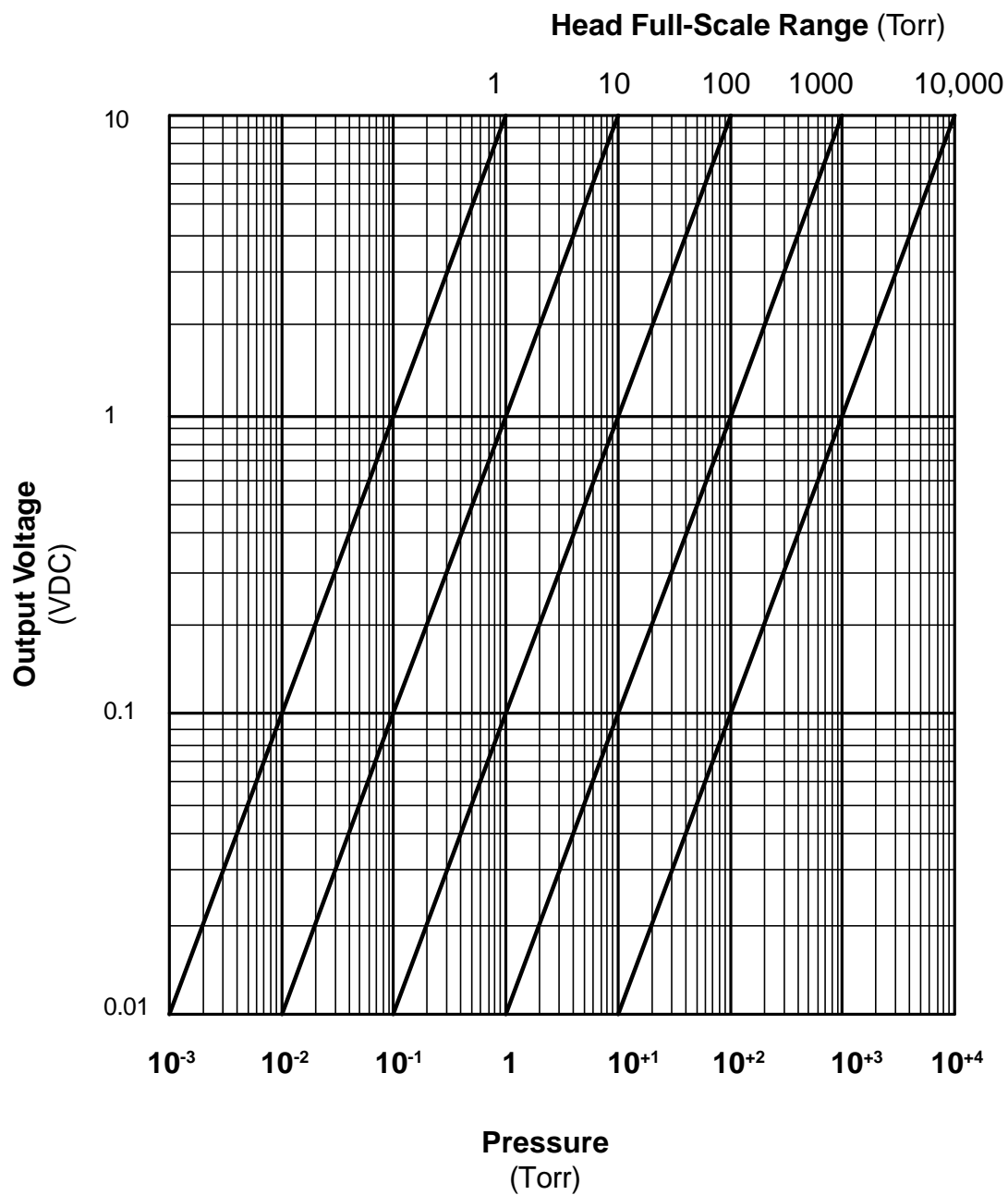

Buffered Analog Output Thermocouple (DV-6M)

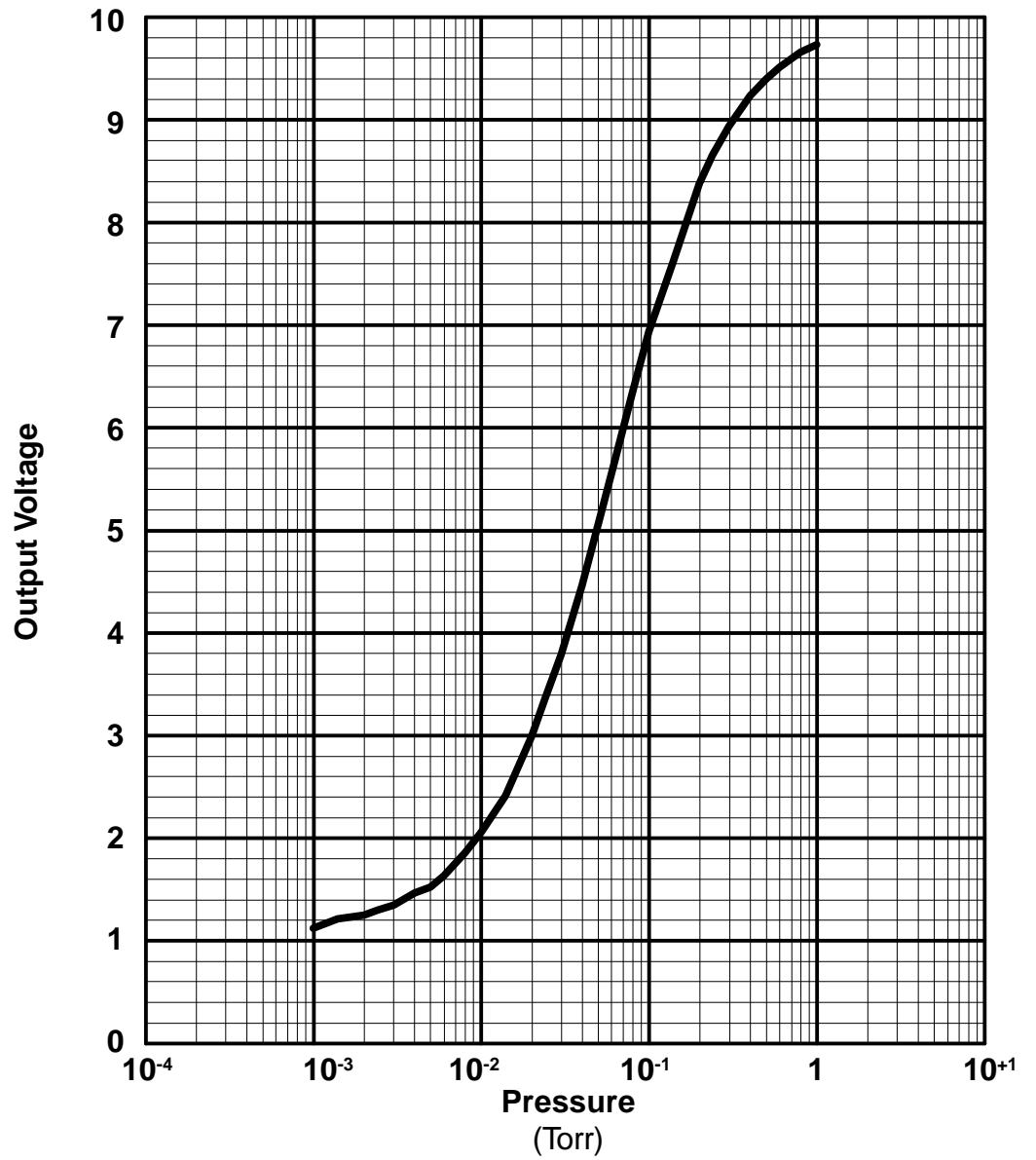

Logarithmic and Combination Output All Sensors

