



119474-P1
Rev B, 10/97
Instruction Manual

MKS Type 1479A Mass-Flo® Controller



WARRANTY

Type 1479A Equipment

MKS Instruments, Inc. (**MKS**) warrants that for two years from the date of shipment the equipment described above (the "equipment") manufactured by **MKS** shall be free from defects in materials and workmanship and will correctly perform all date-related operations, including without limitation accepting data entry, sequencing, sorting, comparing, and reporting, regardless of the date the operation is performed or the date involved in the operation, provided that, if the equipment exchanges data or is otherwise used with equipment, software, or other products of others, such products of others themselves correctly perform all date-related operations and store and transmit dates and date-related data in a format compatible with **MKS** equipment. THIS WARRANTY IS **MKS'** SOLE WARRANTY CONCERNING DATE-RELATED OPERATIONS.

For the period commencing with the date of shipment of this equipment and ending two years later, **MKS** will, at its option, either repair or replace any part which is defective in materials or workmanship or with respect to the date-related operations warranty without charge to the purchaser. The foregoing shall constitute the exclusive and sole remedy of the purchaser for any breach by **MKS** of this warranty.

The purchaser, before returning any equipment covered by this warranty, which is asserted to be defective by the purchaser, shall make specific written arrangements with respect to the responsibility for shipping the equipment and handling any other incidental charges with the **MKS** sales representative or distributor from which the equipment was purchased or, in the case of a direct purchase from **MKS**, with the **MKS** home office in Andover, Massachusetts, USA.

This warranty does not apply to any equipment which has not been installed and used in accordance with the specifications recommended by **MKS** for the proper and normal use of the equipment. **MKS** shall not be liable under any circumstances for indirect, special, consequential, or incidental damages in connection with, or arising out of, the sale, performance, or use of the equipment covered by this warranty.

MKS recommends that all **MKS** pressure and flow products be calibrated periodically (typically every 6 to 12 months) to ensure accurate readings. When a product is returned to **MKS** for this periodic re-calibration it is considered normal preventative maintenance not covered by any warranty.

THIS WARRANTY IS IN LIEU OF ALL OTHER RELEVANT WARRANTIES, EXPRESSED OR IMPLIED, INCLUDING THE IMPLIED WARRANTY OF MERCHANTABILITY AND THE IMPLIED WARRANTY OF FITNESS FOR A PARTICULAR PURPOSE, AND ANY WARRANTY AGAINST INFRINGEMENT OF ANY PATENT.

**MKS Type 1479A
Mass-Flo[®]
Controller**

Copyright © 1997 by MKS Instruments, Inc.

All rights reserved. No part of this work may be reproduced or transmitted in any form or by any means, electronic or mechanical, including photocopying and recording, or by any information storage or retrieval system, except as may be expressly permitted in writing by MKS Instruments, Inc.

Mass-Flo[®] is a registered trademark of MKS Instruments, Inc., Andover, MA

Cajon[®], VCR[®], and VCO[®] are registered trademarks of Cajon Company, Macedonia, OH

Teflon[®] is a registered trademark of E. I. DuPont de Nemours and Co. Inc., Wilmington, DE

Kalrez[®], and Viton[®] are registered trademarks of DuPont Dow Elastomers Wilmington, DE

Swagelok[®] and NUPRO[®] are registered trademarks of Crawford Fitting Company, Solon, OH

Kel-F[®] is a registered trademark of 3M, Minneapolis, MN

DeviceNet[®] is a registered trademark of Open DeviceNet Vendor Association, Inc., Coral Springs, FL

U.S. Patent 5,461,913; foreign patents pending

Table of Contents

Mass Flow Controller Safety Information.....	1
Symbols Used in This Instruction Manual.....	1
Symbols Found on the Unit	2
Safety Procedures and Precautions	3
Chapter One: General Information.....	5
Introduction	5
Design Features.....	5
Reliability	6
Cleanliness Features	6
How This Manual is Organized.....	7
Customer Support.....	8
Chapter Two: Installation	9
How To Unpack the Type 1479 Controller.....	9
Opening the Package	9
Unpacking Checklist.....	10
Environmental Requirements	10
Setup	11
Dimensions	12
Gas Line Connections	13
Standard Fittings	13
Optional Fittings	13
Mounting a Type 1479 MFC.....	13
The Type 2479 MFC	15
Mounting a Type 2479 MFC	15
Interface Cables	16
Generic Shielded Cable Description	17
Example 1: Preferred Method To Connect Cable	18
Example 2: Alternate Method To Connect Cable.....	18
Chapter Three: Overview.....	19

Electrical Connections.....	19
9-Pin Type “D” Connector.....	19
15-Pin Type “D” Connector.....	20
P.C. Edge Card Connector.....	21
The Gas Correction Factor (GCF).....	22
Control Valve.....	23
Chapter Four: Operation.....	25
How To Start Up the Flow Controller.....	25
How To Zero the Flow Controller.....	26
How To Adjust the Controller Gain.....	27
How To Override the Valve.....	28
Priority of the Commands.....	28
The Optional Input.....	29
Chapter Five: Theory of Operation.....	31
Flow Path.....	31
Measurement Technique.....	31
Control Circuitry.....	32
Chapter Six: Maintenance.....	33
General.....	33
Zero Adjustment.....	33
Chapter Seven: Troubleshooting.....	35
Troubleshooting.....	35
How To Adjust the Valve Preload.....	37
Appendix A: Product Specifications.....	43
Performance Specifications.....	43
Environmental Specifications.....	44
Electrical Specifications.....	44
Physical Specifications.....	45
Appendix B: Gas Correction Factors.....	47
Appendix C: MFC Sizing Guidelines.....	51
General Information.....	51

How To Determine the Flow Controller Range	52
How To Determine the Valve Configuration	53
Appendix D: Model Code.....	57
Model Code	57
Index	61

List of Figures and Tables

Figures

Figure 1: Outline Dimensions of the 1479 Flow Controller.....	12
Figure 2: Side View of the 1479 Flow Controller	13
Figure 3: Mounting Dimensions of the 1479 Flow Controller.....	14
Figure 4: Outline Dimensions of the Type 2479 Unit.....	15
Figure 5: Mounting Dimensions of the Type 2479 Flow Controller	15
Figure 6: Preferred Method.....	18
Figure 7: Alternate Method To Use When Cable Clamp is Not Available.....	18
Figure 8: Location of the Retaining Screws	38
Figure 9: Location of the Jam Nut and Adjustment Nut	39
Figure 10: The PC Board.....	41

Tables

Table 1: Definition of Symbols Found on the Unit	2
Table 2: MKS Interface Cables.....	16
Table 3: 9-Pin Type “D” Connector Pinout.....	19
Table 4: 15-Pin Type “D” Connector Pinout.....	20
Table 5: 20-Pin Edge Card Connector Pinout	21
Table 6: Troubleshooting Chart	35
Table 7: Maximum Valve Current	40
Table 8: Required Valve Current Headroom.....	42
Table 9: C_v Pressure Factors	53
Table 10: Valve Configuration Selection Guide.....	54

Mass Flow Controller Safety Information

Symbols Used in This Instruction Manual

Definitions of WARNING, CAUTION, and NOTE messages used throughout the manual.

Warning



The **WARNING** sign denotes a hazard to personnel. It calls attention to a procedure, practice, condition, or the like, which, if not correctly performed or adhered to, could result in injury to personnel.

Caution



The **CAUTION** sign denotes a hazard to equipment. It calls attention to an operating procedure, practice, or the like, which, if not correctly performed or adhered to, could result in damage to or destruction of all or part of the product.

Note



The **NOTE** sign denotes important information. It calls attention to a procedure, practice, condition, or the like, which is essential to highlight.

Symbols Found on the Unit

The following table describes symbols that may be found on the unit.















Definition of Symbols Found on the Unit			
 On (Supply) IEC 417, No.5007	 Off (Supply) IEC 417, No.5008	 Earth (ground) IEC 417, No.5017	 Protective earth (ground) IEC 417, No.5019
 Frame or chassis IEC 417, No.5020	 Equipotentiality IEC 417, No.5021	 Direct current IEC 417, No.5031	 Alternating current IEC 417, No.5032
 Both direct and alternating current IEC 417, No.5033-a	 Class II equipment IEC 417, No.5172-a	 Three phase alternating current IEC 617-2 No.020206	
 Caution, refer to accompanying documents ISO 3864, No.B.3.1	 Caution, risk of electric shock ISO 3864, No.B.3.6	 Caution, hot surface IEC 417, No.5041	

Table 1: Definition of Symbols Found on the Unit

Safety Procedures and Precautions

The following general safety precautions must be observed during all phases of operation of this instrument. Failure to comply with these precautions or with specific warnings elsewhere in this manual violates safety standards of intended use of the instrument and may impair the protection provided by the equipment. MKS Instruments, Inc. assumes no liability for the customer's failure to comply with these requirements.

DO NOT SUBSTITUTE PARTS OR MODIFY INSTRUMENT

Do not install substitute parts or perform any unauthorized modification to the instrument. Return the instrument to an MKS Calibration and Service Center for service and repair to ensure that all safety features are maintained.

SERVICE BY QUALIFIED PERSONNEL ONLY

Operating personnel must not attempt component replacement and internal adjustments. Any service must be made by qualified service personnel only.

USE CAUTION WHEN OPERATING WITH HAZARDOUS MATERIALS

If hazardous materials are used, observe the proper safety precautions, completely purge the instrument when necessary, and ensure that the material used is compatible with the wetted materials in this product, including any sealing materials.

PURGE THE INSTRUMENT

After installing the unit, or before removing it from a system, purge the unit completely with a clean, dry gas to eliminate all traces of the previously used flow material.

USE PROPER PROCEDURES WHEN PURGING

This instrument must be purged under a ventilation hood, and gloves must be worn for protection.

DO NOT OPERATE IN AN EXPLOSIVE ENVIRONMENT

To avoid explosion, do not operate this product in an explosive environment unless it has been specifically certified for such operation.

USE PROPER FITTINGS AND TIGHTENING PROCEDURES

All instrument fittings must be consistent with instrument specifications, and compatible with the intended use of the instrument. Assemble and tighten fittings according to manufacturer's directions.

CHECK FOR LEAK-TIGHT FITTINGS

Carefully check all vacuum component connections to ensure leak-tight installation.

OPERATE AT SAFE INLET PRESSURES

Never operate at pressures higher than the rated maximum pressure (refer to the product specifications for the maximum allowable pressure).

INSTALL A SUITABLE BURST DISC

When operating from a pressurized gas source, install a suitable burst disc in the vacuum system to prevent system explosion should the system pressure rise.

KEEP THE UNIT FREE OF CONTAMINANTS

Do not allow contaminants to enter the unit before or during use. Contamination such as dust, dirt, lint, glass chips, and metal chips may permanently damage the unit or contaminate the process.

ALLOW THE UNIT TO WARM UP

If the unit is used to control dangerous gases, they should not be applied before the unit has completely warmed up. Use a positive shutoff valve to ensure that no erroneous flow can occur during warm up.

Chapter One: General Information

Introduction

The MKS Type 1479A Mass-Flo[®] controller (MFC) is a metal sealed unit which accurately measures and controls the mass flow rates of gases. The Type 2479A MFC adds a pneumatically operated positive shutoff valve downstream. Based upon a patented MKS measurement technique, the instrument is a laminar flow device whose precise indication of mass flow is achieved through the use of a bypass element in parallel with a sensor tube. The 1479 controller has a three-inch footprint and features the ability to accept TTL level commands to remotely open and close the control valve. The controller includes a metal cover and RF bypass capacitors, and incorporates a design that virtually eliminates RFI and EMI interference. The 1479 MFC carries a CE Mark indicating compliance with the EMC Directive 89/336/89.

Use the 1479 MFC when both gas flow control and measurement are required. The controller is available with the flow control valve in a normally closed configuration.

The 1479 mass flow controller (MFC) can interface to complementary MKS equipment (Types 147/647, 160, 246, 247) to display the reading and to provide the power, and set point commands. (Additionally, the 167 unit can be used as a readout and set point generator, but it does not supply power; the 660 unit can be used as a power supply and readout, though it cannot send a set point to the flow controller.) Refer to the corresponding manuals for requirements and instructions.

The 1479 flow controller is available in a variety of types and configurations to suit specific needs. The options that must be specified when you order the flow controller include:

- *Connector:* Type “D” connector or recessed P.C. Edge Card connector
- *Range:* 10, 20, 50, 100, 200, 500, 1000, 2000, 5000, 10,000, 20,000* sccm (N₂ equivalent) * Consult *the factory for 20,000 sccm applications*
- *Fittings:* Cajon[®] 4-VCR[®] male compatible, ¼ inch Swagelok[®] compatible, and ¼ inch diameter tube weld stub.

Design Features

The design of the 1479 flow controller incorporates an advanced flow sensor, a new control valve, and an optimized bypass. (U.S. and Foreign Patents; Patents Pending on the sensor.) The latest generation two-element sensing circuit provides accurate, repeatable performance even in low flow ranges (< 10 sccm). A low temperature effect from ambient temperature change and a low altitude sensitivity effect are also ensured. The newly optimized sensor/bypass arrangement minimizes the flow splitting error for gases with different densities, which dramatically improves measurement accuracy when gases other than the calibration gas are used. The surface mount electronics feature optional pin-to-pin compatibility with other manufacturer’s flow controllers. In addition, the variable valve control electronics provides for fast response to any set point.

Reliability

To help provide excellent reliability, the design contains a low mechanical and electronic components count and has successfully passed the following tests:

- STRIFE, including temperature cycling and vibration (sine and random tests)

and with an overall metal braided, shielded cable, properly grounded at both ends:

- EMC Directive 89/336/EEC for CE Mark compliance

Cleanliness Features

The 1479 controller uses metal for all external seals, thus eliminating elastomeric seals which are a key source of particle generation, outgassing, and permeation. The metal seal also ensures extremely low external leakage. The internal valve control plug is Teflon[®] or Kel-F[®] (depending on flow range) or Kel-F (depending on flow range) which further reduces outgassing and particle generation. The 1479A mechanical design minimizes wetted surface area and virtual leaks, assuring rapid drydown. To further enhance cleanliness, all internal surfaces are precision machined, electropolished, and subjected to a proprietary cleaning process under Class 100 conditions. The instrument is assembled and double-bagged in a Class 100 environment.

How This Manual is Organized

This manual is designed to provide instructions on how to set up and install a Type 1479 unit.

Before installing your Type 1479 unit in a system and/or operating it, carefully read and familiarize yourself with all precautionary notes in the *Safety Messages and Procedures* section at the front of this manual. In addition, observe and obey all WARNING and CAUTION notes provided throughout the manual.

Chapter One: General Information, (this chapter) introduces the product and describes the organization of the manual.

Chapter Two: Installation, explains environmental requirements and practical considerations to take into account when selecting the proper setting for the mass flow controller.

Chapter Three: Overview, describes, in a general way, how the flow controller operates in a gas flow system. This chapter also provides information on how to use a Gas Correction Factor when interpreting the output signal for a gas other than the calibration gas.

Chapter Four: Operation, explains how to start up and operate the mass flow controller. It also discusses how to override the control valve.

Chapter Five: Theory of Operation, provides additional information on how the flow controller operates.

Chapter Six: Maintenance, lists a few general practices to follow to ensure that the flow controller will perform optimally.

Chapter Seven: Troubleshooting, includes a table of hints for reference in the event that your flow controller malfunctions.

Appendix A: Product Specifications, lists the specifications of the instrument.

Appendix B: Gas Correction Factors, provides a table listing the gas correction factors for the most commonly used gases.

Appendix C: MFC Sizing Guidelines, is provided for reference and describes how to calculate the correct size MFC for an application. This information is useful if you need to purchase another MFC or if you plan to use your MFC in another, different application.

Appendix D: Model Code, provides product code information for the 1479 unit.

Customer Support

Standard maintenance and repair services are available at all of our regional MKS Calibration and Service Centers, listed on the back cover. In addition, MKS accepts the instruments of other manufacturers for recalibration using the Primary and Transfer Standard calibration equipment located at all of our regional service centers. Should any difficulties arise in the use of your Type 1479 instrument, or to obtain information about companion products MKS offers, contact any authorized MKS Calibration and Service Center. If it is necessary to return the instrument to MKS, please obtain an ERA Number (Equipment Return Authorization Number) from the MKS Calibration and Service Center before shipping. The ERA Number expedites handling and ensures proper servicing of your instrument.

Please refer to the inside of the back cover of this manual for a list of MKS Calibration and Service Centers.

Warning

All returns to MKS Instruments must be free of harmful, corrosive, radioactive, or toxic materials.

Chapter Two: Installation

How To Unpack the Type 1479 Controller

MKS has carefully packed the 1479 flow controller so that it will reach you in perfect operating order. Upon receiving the unit, however, you should check for defects, cracks, broken connectors, etc., to be certain that damage has not occurred during shipment.

Note

Do *not* discard any packing materials until you have completed your inspection and are sure the unit arrived safely.

If you find any damage, notify your carrier and MKS immediately. If it is necessary to return the unit to MKS, obtain an ERA Number (Equipment Return Authorization Number) from the MKS Service Center before shipping. Please refer to the inside of the back cover of this manual for a list of MKS Calibration and Service Centers.

Opening the Package

The 1479 controller is assembled, leak tested with helium, and calibrated in a clean room environment. The instrument is double-bagged in this environment to ensure maintenance of its particle free condition during shipment. It is very important to remove the bags according to clean room practices. To maintain at least a minimal level of clean room standards, follow the instructions below.

1. Remove the outer bag in an ante room (garmenting room) or transfer box.
Do not allow this outer bag to enter the clean room.
2. Remove the inner bag in the clean room.

Unpacking Checklist

Standard Parts:

- The 1479 flow controller

Optional Accessories:

- Electrical Connector Accessories Kit, 1479A-K1 (includes a mating connector for the I/O connector)
- Power Supply/Readout device
- Cabling to connect the flow controller to the readout device

Environmental Requirements

Follow the guidelines listed below when installing and using the 1479 flow controller.

1. Maintain the normal operating temperature between 0° and 50° C (32° and 122° F).
2. Observe the pressure limits:
 - A. Maximum gas inlet pressure is 250 psig.
 - B. Operational differential pressure is:
 - 10 to 40 psid for ≤ 5000 sccm units
 - 15 to 40 psid for 10,000 and 20,000 sccm unitsThe standard valve configuration provides control over this range with the outlet at atmospheric pressure.
3. Provide power input at ± 15 VDC ($\pm 5\%$) @ 200 mA.
 - A. Maximum voltage/current at startup is ± 15 VDC ($\pm 5\%$) @ 200 mA.
 - B. Typical steady state voltage/current should be ± 15 VDC ($\pm 5\%$) @ 100 mA.
4. Allow 2 minutes for warm-up time.
5. Use high purity gas and filters in line upstream of the MFC.
6. Leave the power to the instrument on at all times, for optimal performance.

For additional information refer to *Appendix A: Product Specifications*, page 43.

Setup

Follow the guidelines below when setting up the 1479 flow controller.

1. Set the controller into position where it will be connected to a gas supply.

Placement of flow components in an orientation other than that in which they were calibrated (typically horizontal) may cause a small zero shift. The zero offset can be removed according to the instructions in *How To Zero the Flow Controller*, page 26.

2. Install the flow controller in the gas stream such that the flow will be in the direction of the arrow on the side of the controller.

3. Allow adequate clearance for the cable connector and tubing.

Straight Shielded connectors require approximately 3" (76.2 mm) height. Right Angle connectors require approximately 2" (50.8 mm) height.

4. Position the flow controller to provide access to the zero potentiometer.

The zero potentiometer is located on the inlet side of the flow controller body.

Refer to Figures 1, and 2, page 13, for outline dimensions, and Figure 3, page 14, for mounting dimensions of the flow controller.

Dimensions

Note  All dimensions are listed in inches with millimeters referenced in parentheses.

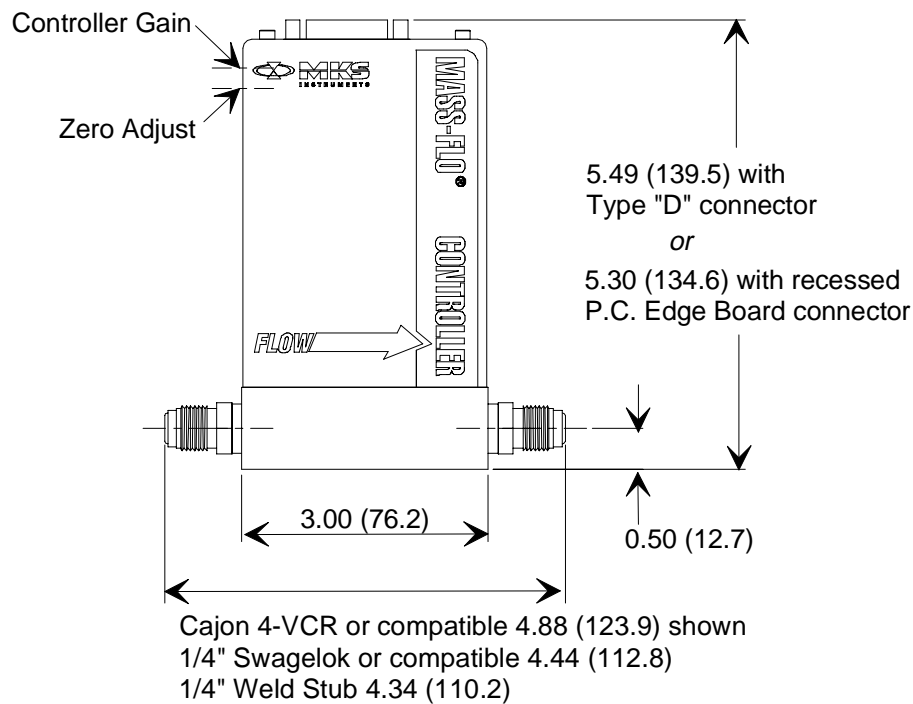



Figure 1: Outline Dimensions of the 1479 Flow Controller

Note  The method used to measure the overall length of the unit varies with the type of fitting. For VCR compatible fittings, the unit is measured from mating face to mating face. For Swagelok compatible fittings, the unit is measured from fitting end to fitting end (less nut). Weld stubs are measured from end to end.

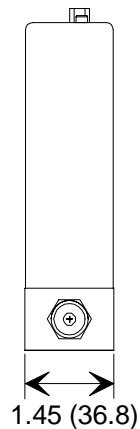

Figure 2: Side View of the 1479 Flow Controller

Gas Line Connections

Connect the gas line (via tubing) from the gas supply to the flow controller's inlet, and from the flow controller's outlet, to the downstream tubing.

Standard Fittings

The 1479 flow controller is equipped with Cajon 4-VCR male compatible fittings. For specific information regarding these fittings, refer to the manufacturer's documentation.

Optional Fittings

As an option, ¼ inch Swagelok compatible, or ¼ inch weld stubs are available when specified.

Mounting a Type 1479 MFC

Tapped holes are provided in the base of the unit for mounting. Refer to Figure 3 for the size and location of the mounting holes.

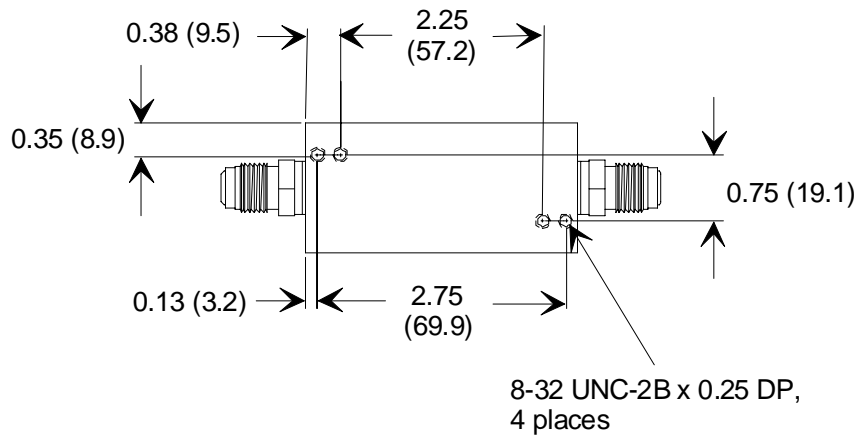

Figure 3: Mounting Dimensions of the 1479 Flow Controller

The Type 2479 MFC

The Type 2479 unit consists of a Type 1479 flow controller configured with a pneumatically operated positive shutoff valve downstream. The pneumatically operated valve is used in series with a mass flow controller when a no-leakage condition is required. The shutoff valve is an all 316L VAR SST diaphragm valve with a Kel-F[®] valve seat. It has a maximum leak rate across the ports and to the outside of 4×10^{-9} sccm He. The air operator port is a 1/8 NPT (National Pipe Thread) internal fitting. The positive shutoff valve requires approximately 75 psig to open the valve. A mounting plate (MKS p/n 119000-P1) is attached to the unit to secure it in place and make it a drop-in replacement for other MKS MFCs with close coupled shutoff valves.

Mounting a Type 2479 MFC

Mount each assembly horizontally, if possible. Placement of flow components in a different orientation may cause a small zero shift. The zero offset can be removed according to the instructions in *How To Zero the Flow Controller*, page 26.

Refer to Figure 4 for the location of the mounting holes on the aluminum plate.

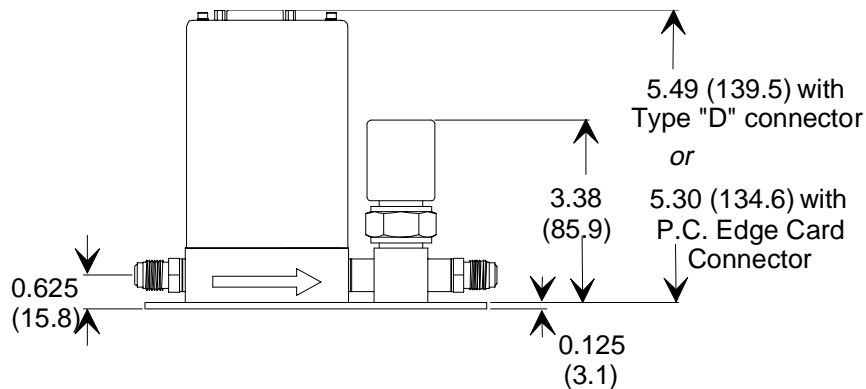

Figure 4: Outline Dimensions of the Type 2479 Unit

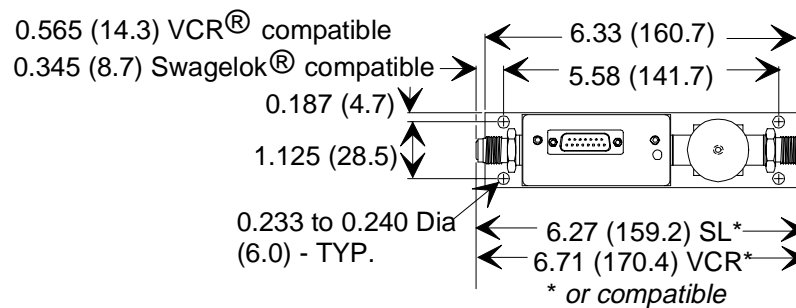

Figure 5: Mounting Dimensions of the Type 2479 Flow Controller

Interface Cables

As of January 1, 1996, all products shipped to the European Community must comply with the EMC Directive 89/336/EEC, which covers radio frequency emissions and immunity tests. MKS products that meet these requirements are identified by application of the CE Mark.

This MKS product meets CE Mark requirements, per EMC Directive 89/336/EEC. To ensure compliance when installed, an overall metal braided shielded cable, properly grounded at both ends, is required during use.

Note

Units with an Edge Board connector or flying leads are not CE Mark compliant.

MKS offers a variety of interface cables, listed in Table 2.

Note

1. An overall metal braided, shielded cable, properly grounded at both ends, is required to meet CE Mark specifications.
 2. To order an overall metal, braided, shielded cable, add an “S” after the cable type designation. For example, to order a standard connection cable to connect the 1479 MFC to a power supply with a 15-pin Type “D” connector, use part number CB259-5; for an overall metal braided, shielded cable use part number CB259S-5.
-

MKS Interface Cables		
MFC End	Power Supply End	
	15-Pin Type “D”	Flying Leads
15-pin Type “D”	CB147-1 CB259-5	CB259-6
20-pin Edge Card	CB147-7 CB259-10	Non terminated CB259-12
9-pin Type “D”	CB147-12	Not Available

Table 2: MKS Interface Cables

Generic Shielded Cable Description

MKS offers a full line of cables for all MKS equipment. Should you choose to manufacture your own cables, follow the guidelines listed below:

1. The cable must have an overall metal *braided* shield, covering all wires. Neither aluminum foil nor spiral shielding will be as effective; using either may nullify regulatory compliance.
2. The connectors must have a metal case which has direct contact to the cable's shield on the whole circumference of the cable. The inductance of a flying lead or wire from the shield to the connector will seriously degrade the shield's effectiveness. The shield should be grounded to the connector before its internal wires exit.
3. With very few exceptions, the connector(s) must make good contact to the device's case (ground). "Good contact" is about 0.01 ohms; and the ground should surround all wires. Contact to ground at just one point may not suffice.
4. For shielded cables with flying leads at one or both ends; it is important at each such end, to ground the shield *before* the wires exit. Make this ground with absolute minimum length. Refer to Figures 6 and 7, page 18. (A ¼ inch piece of #22 wire may be undesirably long since it has approximately 5 nH of inductance, equivalent to 31 ohms at 1000 MHz). After picking up the braid's ground, keep wires and braid flat against the case. With very few exceptions, grounded metal covers are not required over terminal strips. If one is required, it will be stated in the Declaration of Conformity or in the instruction manual.
5. In selecting the appropriate type and wire size for cables, consider:
 - A. The voltage ratings;
 - B. The cumulative I^2R heating of all the conductors (keep them safely cool);
 - C. The IR drop of the conductors, so that adequate power or signal voltage gets to the device;
 - D. The capacitance and inductance of cables which are handling fast signals, (such as data lines or stepper motor drive cables); and
 - E. That some cables may need internal shielding from specific wires to others; please see the instruction manual for details regarding this matter.

Example 1: Preferred Method To Connect Cable

(shown on a pressure transducer)

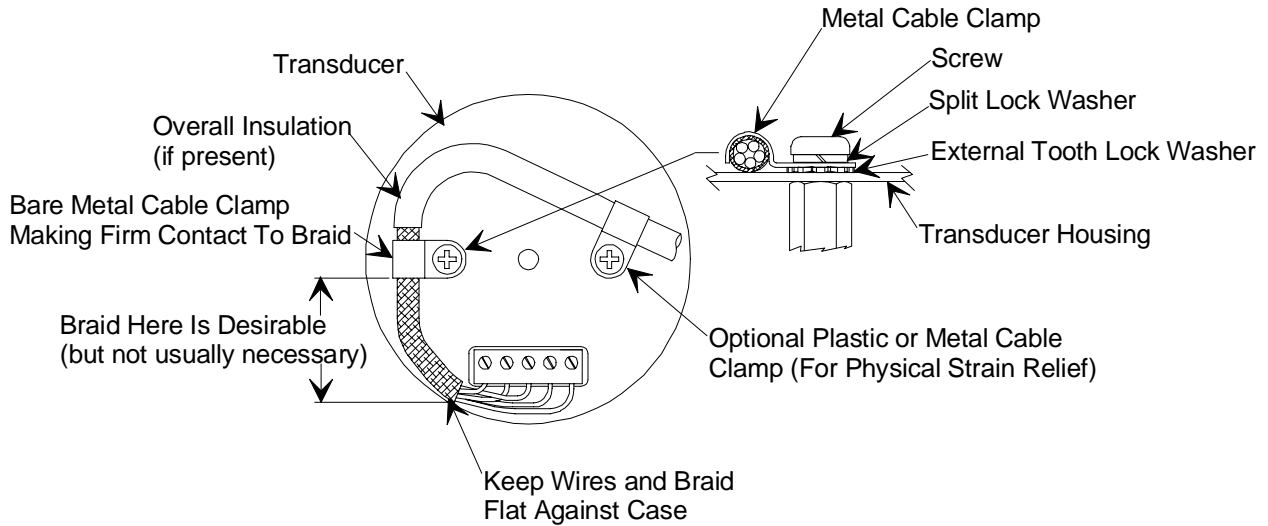

Figure 6: Preferred Method

Example 2: Alternate Method To Connect Cable

(shown on a pressure transducer)

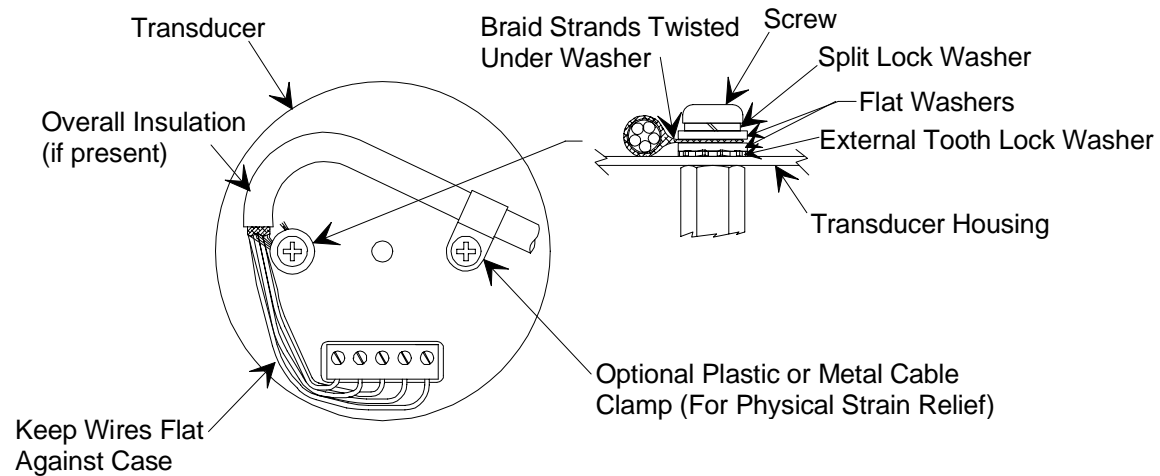

Figure 7: Alternate Method To Use When Cable Clamp is Not Available

Chapter Three: Overview

Electrical Connections

If you are using the 1479 instrument with any equipment other than corresponding MKS power supply/readout units, consult the manufacturer's specifications for connection, and for proper electrical and power characteristics. Refer to *Appendix A: Product Specifications*, page 43, for electrical requirements of the Type 1479 flow controller.

The 1479 MFC is available with either a Type "D," Edge Card, or digital communications connector. Consult factory for the availability of the digital communications connector.

9-Pin Type "D" Connector

Table 4 lists the pinout of the 9-pin Type "D" connector for the 1479 mass flow controller.

9-Pin Type "D" Connector Pinout	
Pin Number	Assignment
1	Valve Open/Close
2	Signal Output
3	+15 V
4	Power Common
5	-15 V
6	Set Point Input
7	Signal Common
8	Signal Common
9	MKS Test Point

Table 3: 9-Pin Type "D" Connector Pinout

Note



1. Chassis ground is not available on a separate pin. Instead, it is carried out through the cable shielding. Be sure that the connector on the other end of the cable is properly grounded to its chassis ground.
2. The 0 to 5 VDC flow signal output comes from pin 2 and is referenced to pin 7 (signal common).
3. Use any appropriate 0 to 5 VDC input signal of less than 20K ohm source impedance referenced to pin 7 as the set point signal to pin 8.

15-Pin Type “D” Connector

Table 4 lists the pinout of the 15-pin Type “D” connector for the 1479 mass flow controller.

15-Pin Type “D” Connector Pinout			
Pin	Assignment	Pin	Assignment
1	MKS Test Point	9	No Connection
2	Flow Signal Output (0 to +5 VDC)	10	Optional Input
3	Valve Close (TTL low)	11	Signal Common
4	Valve Open (TTL low)	12	Signal Common
5	Power Supply Common	13	No Connection
6	-15 VDC	14	No Connection
7	+15 VDC	15	Chassis Ground
8	Set Point Input (0 to +5 VDC)		

Table 4: 15-Pin Type “D” Connector Pinout

Note



1. The “No Connection” pin assignment refers to a pin with no internal connection.
2. The 0 to 5 VDC flow signal output comes from pin 2 and is referenced to pin 12 (signal common).
3. Any appropriate 0 to 5 VDC input signal of less than 20K ohm source impedance referenced to pin 12 can be used to supply a set point signal to pin 8.

P.C. Edge Card Connector

Table 5 shows the pinout of the 20-pin Edge Card connector for the 1479 mass flow controller.

20-Pin Edge Card Connector Pinout			
Pin Number	Function	Pin Number	Function
1	Chassis Ground	A	Set Point Input (0 to +5 VDC)
2	Power Supply Common	B	Signal Common
3	Flow Output (0 to +5 VDC)	C	Signal Common
4	+15 VDC	D	Valve Open (TTL low)
5	Optional Input	E	No Connection
6	No Connection	F	-15 VDC
7	Key	H	Key
8	No Connection	J	MKS Test Point
9	No Connection	K	No Connection
10	Signal Common	L	Valve Close (TTL low)

Table 5: 20-Pin Edge Card Connector Pinout

Note



1. The “No Connection” pin assignment refers to a pin with no internal connection.
2. Pins 1 through 10 are located on one side of the gold finger connection and pins A through L are located on the opposite side of the gold finger connection.
3. The 0 to 5 VDC flow signal output comes from pin 3 and is referenced to pin B (signal ground).
4. Any appropriate 0 to 5 VDC input signal of less than 20K ohm source impedance referenced to pin B can be used to supply a set point signal to pin A.

The Gas Correction Factor (GCF)

A Gas Correction Factor (GCF) is used to indicate the ratio of flow rates of different gases which will produce the same output voltage from a mass flow controller. The GCF is a function of specific heat, density, and the molecular structure of the gases. Since flow controllers are usually calibrated with nitrogen, nitrogen is used as the baseline gas (GCF = 1). *Appendix B: Gas Correction Factors*, page 47, lists the gas correction factors for the most commonly used gases. If the gas you are using is not listed in the appendix, you must calculate its GCF using the following equation:

$$\text{GCF}_x = \frac{(0.3106) (S)}{(d_x) (Cp_x)}$$

where:

GCF_x = Gas Correction Factor for gas X

d_x = Standard Density of gas X, g/l (at 0° C and 760 mmHg)

Cp_x = Specific Heat of gas X, cal/g ° C

0.3106 = (Standard Density of nitrogen) (Specific heat of nitrogen)

S = Molecular Structure correction factor where

S equals:

1.030 for Monatomic gases

1.000 for Diatomic gases

0.941 for Triatomic gases

0.880 for Polyatomic gases

Note



1. When using the GCF, the accuracy of the flow reading may vary by $\pm 5\%$, however, the repeatability will remain $\pm 0.2\%$ of F.S.
2. All MKS readouts have Gas Correction Adjustment controls to provide direct readout.
3. MKS Types 147/647, 167, 246, 247, 260, and 660 readouts provide gas correction factor adjustment.

Control Valve

The Control Valve is a specially constructed solenoid valve in which the armature (moving valve mechanism) is suspended by two springs. This arrangement ensures that no friction is present and makes precise control possible. The 1479 controller has the valve normally *closed*; the control current is used to *lift* the armature and plug assembly *from* the seat, allowing a controlled flow of gas.

This page intentionally left blank.

Chapter Four: Operation

How To Start Up the Flow Controller

1. Leak test the fittings on the MFC using standard leak test procedures.

Do *not* proceed to the next step until you are certain that there is no gas leakage.

2. Plug the power supply/readout cable (MKS or customer-supplied) into the connector (either a 15-pin Type “D” or a PC Edge Card connector) located at the top of the flow controller.

Plug the other end of the cable into an MKS or MKS-compatible power supply/readout unit.

3. Apply power to the MFC instrument.

When power is first applied, the output signal jumps to approximately +7.0 VDC.

You can monitor the flow output signal as the heaters stabilize and the output approaches zero. Approximately 2 minutes after power up, the output signal should be within 10 mV (0.2% F.S.) of the final voltage at all specified flow rates.

Warning



If the instrument is being used to control dangerous gases, be sure that the system is *fully warmed up* before applying gases to the system. You may choose to install a positive shutoff valve to prevent inadvertent gas flow during the warm-up period.

Once the flow controller is completely warmed up, you can proceed to zero the unit as required.

How To Zero the Flow Controller

Ensure that no gas flow is entering the flow controller

1. Apply gas, at a regulated pressure, to the flow controller.
2. Close a positive shutoff valve upstream or downstream of the instrument.
3. Command the control valve open by sending a full scale set point (5 VDC) signal, or:
15-pin Type "D" connector: Connect pin 4 (valve open) to pin 11 or 12 (signal ground)
9-pin Type "D" connector: Supply +5 Volts to pin 1 (to open the valve)
Edge Card connector: Connect pin D (valve open) to pins 10, B, or C (signal ground)

A positive flow may occur momentarily while the gas pressure equalizes across the flow controller.

Note



A set point command signal greater than 50 mV (1% of full scale) is required for the flow controller to generate an output.

Adjust the Zero Pot

1. Once flow through the controller has stopped (reached zero flow) and stabilized, remove the set point or valve open command.
2. Turn the Zero pot (located on the inlet end of the flow controller) until the readout displays zero.

Refer to Figure 1, page 12, for the location of the Zero pot.

If you are using an MKS power supply/readout unit, the flow controller can also be zeroed at the front panel of the readout unit.

3. Open the positive shutoff valve.

The controller may indicate a small, positive flow (<1.0% F.S.) due to a leak through its control valve. However, do **not** "zero out" this flow since it represents an actual flow measurement inherent in the system.

How To Adjust the Controller Gain

Adjust the controller gain if the flow signal oscillates. Reducing the controller gain will reduce the signal oscillation. The controller gain adjustment pot is located on the upstream side of the controller. Refer to Figure 1, page 12, for the location of the gain pot.

- *To decrease flow signal oscillation:* Turn the controller gain counter-clockwise to decrease the controller gain setting.

Note

Lowering the supply pressure to the MFC will have the same effect as decreasing the gain since it will reduce the overflow/underflow effect of the valve.

- *To increase MFC response to a change in set point:* Increase the controller gain slightly. To increase the controller gain, turn the controller gain pot clockwise.

How To Override the Valve

The valve override feature enables the control valve to be fully opened (purged) or closed independent of the set point command signal. Refer to Table 3, page 19, Table 4, page 20, or Table 5, page 21, for the appropriate pin locations.

If the 1479 flow controller is equipped with a 15-pin Type “D” connector:

To *open* the valve, apply a TTL low to pin 4 *or* connect pin 4 to signal ground (pin 12).

To *close* the valve, apply a TTL low to pin 3 *or* connect pin 3 to signal ground (pin 12).

If the 1479 flow controller is equipped with a 9-pin Type “D” connector:

To *open* the valve, apply a +5 Volt signal to pin 1.

To *close* the valve, apply ground to pin 1.

Note

To control with a TTL signal, use a tri-stated device.

If the 1479 flow controller is equipped with an Edge Card connector:

To *open* the valve, apply a TTL low to pin D *or* connect pin D to signal ground (pin 10).

To *close* the valve, apply a TTL low to pin L *or* connect pin L to signal ground (pin 10).

Priority of the Commands

The 1479 flow controller executes commands based on a hierarchical command structure. The highest priority command is Valve Open, followed by Valve Close, and Set Point Control. Therefore, if the flow controller is operating under Set Point Control, you can send a Valve Open command to force the valve to the full open position.

Note

When both the Valve Close and Valve Open pins are pulled down, the Valve Open command takes precedence and the valve is moved to the open position.

The Optional Input

The 1479/2479 MFCs can control flow based on a 0 to 5 Volt signal from an external sensing device using the optional input feature. A common application of this feature is for pressure control using input from a pressure transducer.

To use the optional input feature, route the output from the desired external device to the appropriate “optional input” position for the connector; either a 15-pin Type “D” or an Edge Card Connector. For the connector pinouts, refer to Table 4, page 20, and Table 5, page 21, respectively.

Note

The 9-pin Type “D” connector does not support the optional input feature. This feature is only available on the 15-pin Type “D” and Edge Card connectors.

Voltage applied to the optional input pin overrides the signal generated by the flow sensor internal to the 1479 unit. The control electronics drives the valve so that the optional input signal matches the set point. Use the same pin for the set point signal, regardless of whether you are using the optional input or the standard flow control signal.

Metered flow output is still available on the standard output pin.

This page intentionally left blank.

Chapter Five: Theory of Operation

The 1479 Flow Controller measures the mass flow rate of a gas and controls the flow rate according to a given set point. The control range is from 2 to 100% of Full Scale (F.S.) with an accuracy of $\pm 1\%$ of F.S.

Flow Path

Upon entering the flow controller, the gas stream passes first through the metering section of the instrument for its mass flow to be measured. The gas moves on through the control valve for its rate of flow to be regulated according to the given set point, and then exits the instrument at the established rate of flow.

The metering section consists of one of the following:

- A sensor tube for ranges ≤ 10 sccm (N_2 equivalent)
- A sensor tube and parallel bypass for ranges > 10 sccm (N_2 equivalent)

The geometry of the sensor tube, in conjunction with the specified full scale flow rate, ensures fully developed laminar flow in the sensing region. The bypass elements are specifically matched to the characteristics of the sensor tube to achieve a laminar flow splitting ratio which remains constant throughout each range.

Measurement Technique

The flow measurement is based on differential heat transfer between the temperature sensing heater elements which are attached symmetrically to the sensor tube. This senses the thermal mass movement which is converted to mass flow via the specific heat, C_p , of the gas. The resulting signal is amplified to provide a 0 to 5 VDC output which is proportional to mass flow.

Control Circuitry

The controller employs the above measurement technique and utilizes a control circuit that provides drive current for the proportioning control valve. The flow controller accepts a 0 to 5 VDC set point signal, compares it to its own flow signal, and generates an error voltage. This error signal is then conditioned by a PID (Proportional-Integral-Derivative) algorithm and amplified so that it can reposition the control valve, thus reducing the control error to zero.

Since the control valve is *normally closed*, the 1479 unit lifts the armature and plug assembly *from* the seat to regulate the gas flow rate.

Chapter Six: Maintenance

General

In general, no maintenance is required other than proper installation and operation, and zero adjustment. If a controller fails to operate properly upon receipt, check for shipping damage, and check the power/signal cable for correct continuity. Any damage should be reported to the carrier and MKS Instruments immediately. If there is no obvious damage and the continuity is correct, obtain an ERA Number (Equipment Return Authorization Number) before returning the unit to MKS Instruments for service.

Contact any authorized MKS Sales Office or Calibration and Service Center should you encounter any difficulties or problems using your flow controller.

Note



If it is necessary to return the instrument to MKS for repair, please contact any of the MKS international service/calibration centers listed on the inside of the back cover of this manual for an ERA (Equipment Return Authorization) number to expedite handling and ensure proper servicing of your instrument.

Zero Adjustment

For best accuracy and repeatability, you should check the zero setting periodically and reset it, if necessary. Refer to *How To Zero the Flow Controller*, page 26, for instructions on setting the zero. The frequency of checking the zero is dependent on the specific accuracy and repeatability required by your process. It is also recommended that the instrument be recalibrated annually if no other time interval has been specifically established. Refer to the inside of the back cover of this instruction manual for a complete list of MKS Calibration and Service centers.

This page intentionally left blank.

Chapter Seven: Troubleshooting

Troubleshooting

Refer to the troubleshooting chart should you encounter a problem with your 1479 unit.

Troubleshooting Chart		
Symptoms	Possible Cause	Remedy
No output or overrange at zero (after warm-up)	Improper cable	Check cable for type
	Valve override function applied	Disconnect valve override
	Electronics malfunctioning	Return for service
Unit indicates a negative flow	Unit installed in gas stream backwards	Reinstall unit in proper flow direction
Controller does not track set point	Improper zero adjustment	Zero meter output, according to <i>How To Zero the Flow Controller</i> , page 26
Controller does not function	Electronics malfunctioning	Return for service
Oscillation	Too high a controller gain setting	Reduce (turn counter-clockwise)
	Incorrect upstream pressure regulator	Check manufacturers' specifications
	Upstream pressure too high	Reduce upstream pressure
	Excessive valve preload	Readjust the valve, according to <i>How To Adjust the Valve Preload</i> , page 37
Excessive closed conductance	Inadequate valve preload	Readjust the valve, according to <i>How To Adjust the Valve Preload</i> , page 37

Table 6: Troubleshooting Chart
(Continued on next page)

Troubleshooting Chart (Continued)		
Symptoms	Possible Cause	Remedy
Unit does not achieve full flow	Upstream pressure too low	Increase upstream pressure
	Excessive valve preload	Readjust the valve, according to <i>How To Adjust the Valve Preload</i> , page 37
	Incorrect maximum valve current setting	Return for service

Table 6: Troubleshooting Chart

How To Adjust the Valve Preload

Caution



-
- 1. All valves are adjusted at the factory for proper leak integrity and flow control response. Adjust the valve *ONLY* if the *Troubleshooting Chart*, Table 6, page 35, recommends that you do so.**
 - 2. Only qualified individuals should perform the installation and any user adjustments. They must comply with all the necessary ESD and handling precautions while installing and adjusting the instrument. Proper handling is essential when working with all highly sensitive precision electronic instruments.**
-

Note



Valve preload adjustment cannot be performed in situ because the procedure involves disassembling the MFC. Perform this procedure on a properly equipped workbench.

This procedure requires the following equipment:

- Any special safety equipment necessary to handle the gas in use
- $\frac{3}{32}$ " allen wrench for the enclosure retaining and bracket hold down screws (4-40 socket head cap screws)
- #1 Phillips screwdriver
- 13 mm open end wrench for the adjustment nut
- Flat 17 mm open end wrench for the jam nut (a bicycle cone wrench works well)
- Digital Multi Meter (DMM)
- Gas supply (N₂, Ar, or He) with a local shutoff valve and a 0 to 40 psi regulator
- Suitable MFC controller/power supply with cables
- Clip lead

1. Set your processing system to supply the MFC with a non-hazardous gas (Ar, N₂, or He) and purge thoroughly.

Warning

You MUST use a “safe” gas while making any valve adjustments to safeguard against inadvertent exposure to any toxic or hazardous gas. DO NOT adjust the valve while a hazardous or toxic gas is flowing through the MFC.

If you cannot use a “safe” gas within your processing system, remove the MFC and purge the unit as required by your corporate policies and any appropriate safety procedures.

2. Disconnect the cable to power down the unit and remove the unit from the process tool.
3. Connect the inlet of the unit to the gas supply and adjust the pressure to the maximum level used on the process tool.

Choose a “safe” gas with a similar molecular weight as the actual process gas. More specifically, helium is best used as a substitute for other very light gases such as hydrogen.

4. Use a ³/₃₂” allen wrench to remove the enclosure retaining screws. Remove the enclosure cover.

Figure 8 shows the location of the retaining screws.

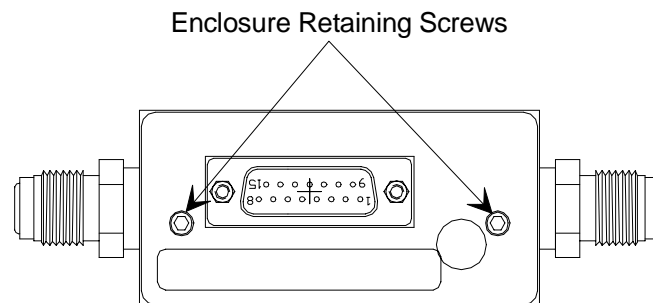

Figure 8: Location of the Retaining Screws

5. Disconnect the leads from the control valve to the PC board.
6. Remove the two (2) 4-40 socket head cap screws and the two (2) 2-56 Phillips head screws (holding the PC brackets). Gently lay the bracket/PC board assembly on the bench top.

Handle the unit carefully to avoid damaging the flex print that connects the sensor and the main PC board.

7. Reconnect the cable from the controller/power supply and power up the unit.

Warning

Follow your corporate policy on handling toxic or hazardous gases. Your corporate policy on handling these gases *supersedes* the instructions in this manual. MKS assumes no liability for the safe handling of such materials.

If appropriate, remove the MFC from the process tool and make the adjustments using a surrogate gas.

8. Close all isolation valves in the system, both upstream and downstream of the MFC.
9. Zero the unit, following the instructions in *How To Zero the Flow Controller*, page 26.
10. Reconnect one electrical valve lead to a post on the PC Control board via a short clip lead and the other via a DMM in series. (The leads are interchangeable.) Set the DMM to measure current in the 10 to 100 mA range.
11. Open all upstream and downstream isolation valves in the system.
12. Hold the valve adjustment nut in place with a 13 mm crescent wrench and loosen the jam nut using a flat 17 mm crescent wrench.

Refer to Figure 9 for the location of the adjustment nut and jam nut.

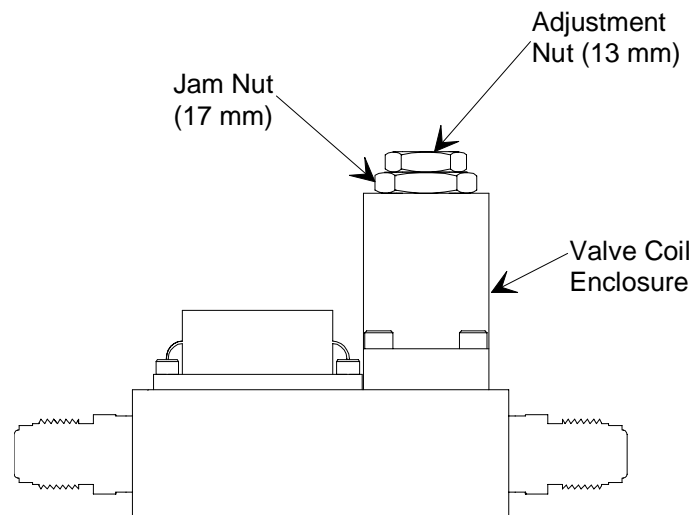

Figure 9: Location of the Jam Nut and Adjustment Nut

13. Provide a set point input signal to the MFC of 0.25 Volts to represent 5% flow.

14. *Slowly* turn the adjustment nut while monitoring the DMM: clockwise rotation increases the current required to open the valve; counterclockwise rotation decreases it. ***Adjust to a target value of 25 mA.***

Caution

Do not overturn the adjustment nut! Excessive turning may damage the plug and cause poor closed conductance and flow control.

15. Holding the adjustment nut in place, re-tighten the jam nut. As you tighten the jam nut, monitor the DMM to ensure that the current remains between 24 and 26 mA.

Tightening the jam nut tends to reduce the preload. It may be necessary to repeat the adjustment and jam nut tightening to maintain proper values.

16. Change the set point input signal to 0.0 Volts.

17. Monitor the MFC output to verify that the valve closed conductance is within specification.

Refer to *Appendix A: Product Specifications*, page 43, for the valve closed conductance specification. If the valve fails to meet the closed conductance specification, return the unit to MKS for service.

18. Change the inlet pressure to the minimum pressure expected during use.

19. Change the set point input signal to 5.0 Volts (100% full scale).

20. Observe the MFC output and control valve current. Record the valve current.

The MFC output should be 5.0 Volts (100%) and the valve current no greater than the limits in Table 7. If the valve current *exceeds* these limits, return the unit to MKS for service. If the valve current is less than or equal to the value in Table 7, it must be adjusted.

Maximum Valve Current	
MFC Flow Capacity (N ₂ equivalent)	Maximum Valve Current (at 100% Set Point and Minimum Pressure)
≤50 sccm	39 mA
100 to 500 sccm	45 mA
≥1000 sccm	51 mA

Table 7: Maximum Valve Current

21. Locate the Current Limiting potentiometer, R85, on the PC board.

The potentiometer R85, is located in the top right hand corner of the PC board. It is the only black potentiometer on the board and is much smaller than the other potentiometers.

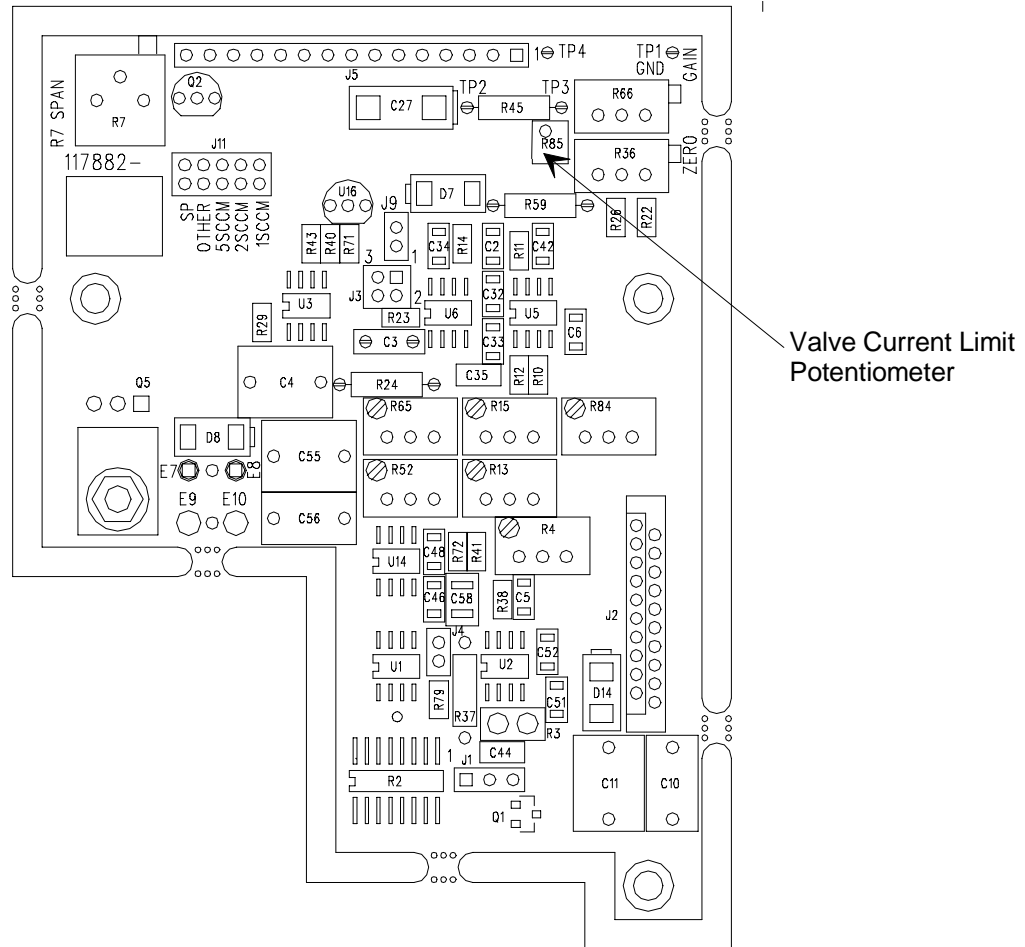

Figure 10: The PC Board

22. Determine the required valve current limit; add the appropriate headroom from Table 8 to the full scale valve current recorded in step 19. .

Required Valve Current Headroom	
MFC Flow Capacity (N₂ equivalent)	Milliamp Value
≤50 sccm	24 mA
100 to 500 sccm	18 mA
≥1000 sccm	12 mA

Table 8: Required Valve Current Headroom

23. Provide a 5 Volt set point signal.
24. Turn off the gas supply.
25. When the flow output has dropped to zero, adjust the Current Limiting potentiometer, R85, until the required valve current limit is obtained.
- Note that counter clockwise rotation increases the maximum current, while clockwise rotation decreases it.
26. Remove the DMM and reconnect the valve lead.
27. Re-install the brackets and PC assembly and reconnect the valve leads.
28. Reposition the enclosure over the unit and tighten the retaining screws.
29. Re-install the MFC into the process system.

Appendix A: Product Specifications

Performance Specifications

Accuracy ¹	±1% F.S.
CE Compliance ²	EMC Directive 89/336/EEC <i>Products with Edge Board connectors and products used with flying leads are not CE compliant.</i>
Control range	2.0 to 100% F.S.
Controller settling time ³	< 2 seconds (to within 2% of set point)
Full scale ranges (nitrogen equivalent)	10, 20, 50, 100, 200, 500, 1000, 2000, 5000, 10,000, 20,000* sccm * <i>Consult factory</i>
Operational differential pressure ⁴ ≤ 5000 sccm 10,000 to 20,000 sccm	10 to 40 psid 15 to 40 psid
Pressure coefficient	0.02% Rdg./psi
Repeatability	± 0.2% F.S.
Resolution (measurement)	0.1% F.S.
Temperature coefficients Zero Span	< 0.05% F.S./° C (500 ppm) <0.08% of Rdg/° C (800 ppm)
Warm-up time (to within 0.2% of steady-state)	2 minutes

¹Includes non-linearity, hysteresis, and non-repeatability referenced to 760 mmHg and 0° C.

² An overall metal braided, shielded cable, properly grounded at both ends, is required during use.

³Controller settling time per SEMI E17-91, specified for flows starting from 0 to 25% (or greater) F.S.

⁴Operational differential pressure is referenced to an MFC outlet pressure at atmosphere.

Environmental Specifications

Storage Humidity Range	0 to 95% relative humidity, non-condensing
Operating Temperature Range	0° to 50° C (32° to 122° F)
Storage Temperature	-20° to 65° C (-4° to 149 F)

Electrical Specifications

CE Mark Compliance	EMC Directive 89/336/EEC
Input voltage/Current required	
Max. at start up (first 5 seconds) ⁵	±15 VDC (±5%) @ 200 mA
Typical at steady state	±15 VDC (±5%) @ 100 mA
Output impedance	< 1 ohm
Output signal/minimum load	0 to 5 VDC into > 10K ohm
Set point command signal (controllers only)	0 to 5 VDC from < 20K ohm

⁵Add 100 mA to start up current if the valve is energized.

Physical Specifications

Body (height x width x length) <i>without fittings</i>	<5.5 in x ≤ 1.5 in x 3 in <14.0 cm x ≤ 3.8 cm x 7.6 cm
Connector options	9-pin Type “D” 15-pin Type “D” 20-pin Edge Card Digital, RS-485 Digital, DeviceNet
Fittings Standard Optional	Cajon® 4-VCR® male compatible ¼” Swagelok compatible, or ¼” tube weld stubs
Internal surface area (500 sccm unit)	7.7 in ² (49.7 cm ²)
Internal volume (500 sccm unit)	0.27 in ³ (4.43 cm ³)
Leak integrity External (scc/sec He) Through closed valve	< 1 x 10 ⁻¹⁰ < 1.0% F.S. @40 psi
Materials wetted Body Seals Valve Seat	316L VAR SST, 316L SST, nickel Metal Kel-F®, Teflon®
Maximum inlet pressure	250 psig
Surface Finish	<16 μinches Ra electropolished
Weight	≤1.9 lbs (0.86 kg)

Due to continuing research and development activities, these product specifications are subject to change without notice.

This page intentionally left blank.

Appendix B: Gas Correction Factors

GAS	SYMBOL	SPECIFIC HEAT, Cp cal/g ⁰ C	DENSITY g/l @ 0 ⁰ C	CONVERSION FACTOR
Air	---	0.240	1.293	1.00
Ammonia	NH ₃	0.492	0.760	0.73
Argon	Ar	0.1244	1.782	1.39 ¹
Arsine	AsH ₃	0.1167	3.478	0.67
Boron Trichloride	BCl ₃	0.1279	5.227	0.41
Bromine	Br ₂	0.0539	7.130	0.81
Carbon Dioxide	CO ₂	0.2016	1.964	0.70 ¹
Carbon Monoxide	CO	0.2488	1.250	1.00
Carbon Tetrachloride	CCl ₄	0.1655	6.86	0.31
Carbon Tetrafluoride (Freon - 14)	CF ₄	0.1654	3.926	0.42
Chlorine	Cl ₂	0.1144	3.163	0.86
Chlorodifluoromethane (Freon - 22)	CHClF ₂	0.1544	3.858	0.46
Chloropentafluoroethane (Freon - 115)	C ₂ ClF ₅	0.164	6.892	0.24
Chlorotrifluoromethane (Freon - 13)	CClF ₃	0.153	4.660	0.38
Cyanogen	C ₂ N ₂	0.2613	2.322	0.61
Deuterium	D ₂	1.722	0.1799	1.00
Diborane	B ₂ H ₆	0.508	1.235	0.44
Dibromodifluoromethane	CBr ₂ F ₂	0.15	9.362	0.19
Dichlorodifluoromethane (Freon - 12)	CCl ₂ F ₂	0.1432	5.395	0.35
Dichlorofluoromethane (Freon - 21)	CHCl ₂ F	0.140	4.592	0.42
Dichloromethylsilane	(CH ₃) ₂ SiCl ₂	0.1882	5.758	0.25

(Table continued on next page)

GAS	SYMBOL	SPECIFIC HEAT, Cp cal/g ^o C	DENSITY g/l @ 0 ^o C	CONVERSION FACTOR
Dichlorosilane	SiH ₂ Cl ₂	0.150	4.506	0.40
1,2-Dichlorotetrafluoroethane (Freon - 114)	C ₂ Cl ₂ F ₄	0.160	7.626	0.22
1,1-Difluoroethylene (Freon - 1132A)	C ₂ H ₂ F ₂	0.224	2.857	0.43
2,2-Dimethylpropane	C ₅ H ₁₂	0.3914	3.219	0.22
Ethane	C ₂ H ₆	0.4097	1.342	0.50
Fluorine	F ₂	0.1873	1.695	0.98
Fluoroform (Freon - 23)	CHF ₃	0.176	3.127	0.50
Freon - 11	CCl ₃ F	0.1357	6.129	0.33
Freon - 12	CCl ₂ F ₂	0.1432	5.395	0.35
Freon - 13	CClF ₃	0.153	4.660	0.38
Freon - 13 B1	CBrF ₃	0.1113	6.644	0.37
Freon - 14	CF ₄	0.1654	3.926	0.42
Freon - 21	CHCl ₂ F	0.140	4.592	0.42
Freon - 22	CHClF ₂	0.1544	3.858	0.46
Freon - 23	CHF ₃	0.176	3.127	0.50
Freon - 113	C ₂ Cl ₃ F ₃	0.161	8.360	0.20
Freon - 114	C ₂ Cl ₂ F ₄	0.160	7.626	0.22
Freon - 115	C ₂ ClF ₅	0.164	6.892	0.24
Freon - 116	C ₂ F ₆	0.1843	6.157	0.24
Freon - C318	C ₄ F ₈	0.1866	8.93	0.164
Freon - 1132A	C ₂ H ₂ F ₂	0.224	2.857	0.43
Helium	He	1.241	0.1786	1.39
Hexafluoroethane (Freon - 116)	C ₂ F ₆	0.1843	6.157	0.24
Hydrogen	H ₂	3.419	0.0899	1.00
Hydrogen Bromide	HBr	0.0861	3.610	1.00

(Table continued on next page)

Appendix B: Gas Correction Factors

GAS	SYMBOL	SPECIFIC HEAT, Cp cal/g°C	DENSITY g/l @ 0°C	CONVERSION FACTOR
Hydrogen Chloride	HCl	0.1912	1.627	1.00
Hydrogen Fluoride	HF	0.3479	0.893	1.00
Isobutylene	C ₄ H ₈	0.3701	2.503	0.29
Krypton	Kr	0.0593	3.739	1.543
Methane	CH ₄	0.5328	0.715	0.72
Methyl Fluoride	CH ₃ F	0.3221	1.518	0.56
Molybdenum Hexafluoride	MoF ₆	0.1373	9.366	0.21
Neon	Ne	0.246	0.900	1.46
Nitric Oxide	NO	0.2328	1.339	0.99
Nitrogen	N ₂	0.2485	1.250	1.00
Nitrogen Dioxide	NO ₂	0.1933	2.052	-. -2
Nitrogen Trifluoride	NF ₃	0.1797	3.168	0.48
Nitrous Oxide	N ₂ O	0.2088	1.964	0.71
Octafluorocyclobutane (Freon - C318)	C ₄ F ₈	0.1866	8.93	0.164
Oxygen	O ₂	0.2193	1.427	1.00
Pentane	C ₅ H ₁₂	0.398	3.219	0.21
Perfluoropropane	C ₃ F ₈	0.194	8.388	0.17
Phosgene	COCl ₂	0.1394	4.418	0.44
Phosphine	PH ₃	0.2374	1.517	0.76
Propane	C ₃ H ₈	0.3885	1.967	0.36
Propylene	C ₃ H ₆	0.3541	1.877	0.41
Silane	SiH ₄	0.3189	1.433	0.60
Silicon Tetrachloride	SiCl ₄	0.1270	7.580	0.28
Silicon Tetrafluoride	SiF ₄	0.1691	4.643	0.35
Sulfur Dioxide	SO ₂	0.1488	2.858	0.69

(Table continued on next page)

Appendix B: Gas Correction Factors

GAS	SYMBOL	SPECIFIC HEAT, Cp cal/g ^o C	DENSITY g/l @ 0 ^o C	CONVERSION FACTOR
Sulfur Hexafluoride	SF ₆	0.1592	6.516	0.26
Trichlorofluoromethane (Freon - 11)	CCl ₃ F	0.1357	6.129	0.33
Trichlorosilane	SiHCl ₃	0.1380	6.043	0.33
1,1,2-Trichloro - 1,2,2-Trifluoroethane (Freon - 113)	CCl ₂ FCClF ₂ or (C ₂ Cl ₃ F ₃)	0.161	8.360	0.20
Tungsten Hexafluoride	WF ₆	0.0810	13.28	0.25
Xenon	Xe	0.0378	5.858	1.32

¹ Empirically defined

² Consult MKS Instruments, Inc. for special applications.

NOTE: Standard Pressure is defined as 760 mmHg (14.7 psia). Standard Temperature is defined as 0^oC.

Appendix C: MFC Sizing Guidelines

General Information

To select the correct MFC for an application, you must determine the:

- flow controller range
- appropriate valve configuration

The flow controller range depends on the desired flow rate and the gas correction factor for the gas to be used. MKS states the flow controller ranges based on flow rate of nitrogen; the flow rate for other gases may vary.

The proper valve configuration depends upon the flow range, inlet pressure, differential pressure across the unit, and density of the gas. Proper valve configurations have been established for all standard flow ranges flowing nitrogen under standard operating pressures. These configurations are suitable for virtually all gases and pressure conditions.

How To Determine the Flow Controller Range

The Type 1479 controller is available in ranges of 10, 20, 50, 100, 200, 500, 1000, 2000, 5000, 10,000, and 20,000 sccm (N₂ equivalent). To select the appropriate range, you must determine the flow rate of nitrogen that is equivalent to the flow rate of the desired gas. Calculate the ratio of the GCF of nitrogen (1.00) to the GCF of the desired gas (refer to *Appendix B: Gas Correction Factors*, page 47) as shown in the following example.

Example:

You need a flow rate of 250 sccm of argon (Ar). What range flow controller should you use?

1. Find the Gas Correction Factor of Ar (refer to *Appendix B: Gas Correction Factors*, page 47).

The GCF for Ar is 1.39.

2. Insert the GCF of Ar in the following formula:

$$\frac{(\text{GCF of N}_2)}{(\text{GCF of Ar})} = \frac{(x)}{(\text{Desired flow rate of Ar})}$$

where x is the equivalent flow rate of nitrogen (sccm).

$$\frac{(1.00)}{(1.39)} = \frac{(x)}{(250 \text{ sccm Ar})}$$

$$x = 180 \text{ sccm N}_2$$

A flow rate of 250 sccm of Ar will produce a flow rate equivalent to 180 sccm of N₂. This falls within the range of a 200 sccm flow controller.

When calculating equivalent N₂ flows using gas correction factors, be sure to use a flow controller with a sufficient flow rate range. For example, if the calculated equivalent N₂ flow in the example shown above is 205 sccm, use a 500 sccm flow controller. The 500 sccm instrument can then be calibrated such that 205 sccm N₂ = full scale.

Note



When using a gas with a density *higher* than nitrogen, be sure that the control valve Full Scale range can accommodate the desired flow rate. Please call the MKS Applications group if you have any questions.

How To Determine the Valve Configuration

1. Determine the maximum flow coefficient (C_v), for the gas of interest, using the equation:

$$C_v (\text{max}) = \left(\text{Max. Flow Rate, sccm} \right) \left(\sqrt{\frac{\text{Gas Density}}{1.293}} \right) \left(C_v \text{ Pressure Factor} \right)$$

where:

Gas Density is listed in *Appendix B: Gas Correction Factors*, page 47.

C_v Pressure Factor is listed in Table 9, page 53.

C_v Pressure Factors (multiplied by 100,000)										
P1 (psia)	Differential Pressure (psid)									
	50	40	30	20	15	10	5	2	1	0.5
265	0.032	0.035	0.040	0.049	0.056	0.068	0.096	0.152	0.214	0.303
215	0.036	0.039	0.045	0.054	0.062	0.076	0.107	0.168	0.238	0.336
165	0.042	0.046	0.052	0.063	0.072	0.087	0.122	0.192	0.272	0.384
150	0.044	0.048	0.055	0.066	0.075	0.092	0.128	0.202	0.285	0.403
125	0.049	0.054	0.061	0.073	0.083	0.101	0.141	0.221	0.312	0.441
100	0.058	0.062	0.069	0.082	0.094	0.113	0.158	0.248	0.349	0.493
75	0.077	0.077	0.082	0.097	0.110	0.132	0.183	0.286	0.404	0.570
50	0.116	0.116	0.116	0.123	0.138	0.164	0.226	0.352	0.495	0.699
30	—	—	0.194	0.194	0.194	0.220	0.297	0.458	0.642	0.904
25	—	—	—	0.232	0.232	0.246	0.329	0.503	0.704	0.991
20	—	—	—	0.291	0.291	0.291	0.373	0.565	0.789	1.109
15	—	—	—	—	0.387	0.387	0.441	0.659	0.915	1.283
10	—	—	—	—	—	0.578	0.581	0.821	1.131	1.578
5	—	—	—	—	—	—	1.156	1.232	1.643	2.261
2	—	—	—	—	—	—	—	2.889	2.905	3.725
1	—	—	—	—	—	—	—	—	5.778	5.811

Table 9: C_v Pressure Factors

2. Select the valve configuration with the C_v value that is closest to, though larger than, the C_v value calculated in step 1.

The C_v value represents the *maximum* flow rate for the unit. Choose the valve configuration *above* your calculated C_v value to ensure that the unit can deliver the required flow.

Valve Configuration Selection Guide		
Valve Configuration	Nominal Range (N₂) sccm	C_v x 10⁵
1	10	2.44
2	20	4.88
3	50	12.21
4	100	24.42
5	200	48.84
6	500	122.11
7	1000	244.22
8	2000	488.44
9	5000	1221.11
10	10000	1924.47
11	20000	3848.94
12	30000	5773.41

Table 10: Valve Configuration Selection Guide

Example

Suppose you need to flow boron trichloride at a rate of 250 sccm and the inlet pressure is 20 psia. Your process runs at atmospheric pressure, so the differential pressure is 5 psid.

1. Determine the maximum flow factor (C_V) for the gas of interest, using the equation listed in step 1, page 53.

The *Gas Density* for boron trichloride, listed in *Appendix B: Gas Correction Factors*, page 47, is 5.227. The *C_V Pressure Factor*, read from Table 9, page 53, for a 20 psia inlet and

5 psid differential pressure, is 0.373. Therefore, our equation becomes:

$$C_V (\text{max}) = \left(250 \text{ sccm} \right) \left(\sqrt{\frac{5.227}{1.293}} \right) \left(0.373 \right)$$

$$C_V = 187.5$$

2. Select the valve configuration with a C_V value that is closest to, though larger than, the C_V value calculated in step 1.

A C_V value of 187.5 falls between 122.11 (configuration 6) and 244.22 (configuration 7). To ensure that the unit can deliver the 250 sccm flow, choose configuration 7.

This page intentionally left blank.

Appendix D: Model Code

Model Code

Use the MKS Type 1479 Mass-Flo® Controller (MFC) when both gas flow control and measurement are required. The instrument is available with the flow control valve in a normally closed configuration. The desired options are identified in the model code when you order the unit.

The model code is identified as follows:

1479AXXXY1WZ

where:

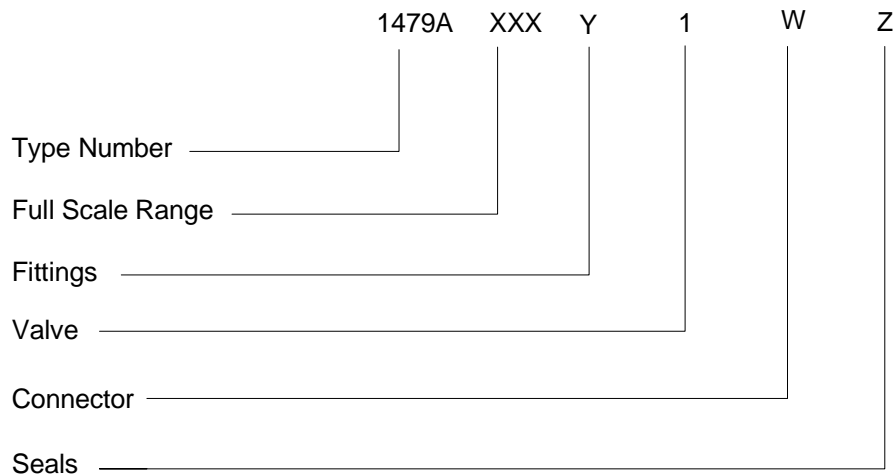

Type Number (1479A)

This designates the model number of the instrument. The mass flow controller is identified as the Type 1479A.

Full Scale Range - sccm of Nitrogen (XXX)

The full scale range is indicated by a two digit / one letter code.

Full Scale Range	Ordering Code
10	11C
20	21C
50	51C
100	12C
200	22C
500	52C
1,000	13C
2,000	23C
5,000	53C
10,000	14C
20,000	24C

Fittings (Y)

Three types of fittings are available, designated by a single letter code.

	Ordering Code
Cajon® 4-VCR® Male	R
Swagelok ¼" tube	S
¼" tube weld stub	A

Valve (1)

The valve configuration is designated by a single number code.

	Ordering Code
Normally Closed	1
Normally Open*	2

** Consult factory for availability*

Connector (W)

Five types of connectors are available, indicated by a single letter or number code.

	Ordering Code
9-pin Type "D"	A
15-pin Type "D"	B
20-pin Edge Card	C
Digital, RS-485*	5
Digital, DeviceNet®*	6

** Consult factory for availability*

Seals (Z)

The all-metal seals are indicated by a single letter code.

	Ordering Code
All-metal	M

How To Order a Mass Flow Controller

To order the Type 1479 MFC with a 500 sccm full scale range, Cajon 4-VCR fittings, a normally closed valve, 15-pin Type "D" connector, and an all-metal seal, the product code is:

1479A 52C R 1 B M

This page intentionally left blank.

Index

C

- Connections, 13
- Connector
 - 1479 Edge Card, 21
 - 1479 Type "D", 19, 20
- Control circuitry, 32
- Control valve, 23
- Customer support, 8

D

- Design, 5
- Dimensions, 12

E

- Electrical
 - connections, 19–21
- Electrical specifications, 44
- Environmental requirements, 10
- Environmental specifications, 44

F

- Fittings, 13
- Flow path, 31

G

- Gas connections, 13
- Gas correction factor, 22, 47

I

- Interface cables, 16
- Interface connectors, 16
- Introduction, 5

L

- Leak rate, 15

M

- Maintenance, 33
- Manual organization, 7
- Measurement technique, 31
- Mounting, 13

N

- NUPRO valve, 15

P

- Performance specifications, 43
- Physical specifications, 45
- PID control, 32
- Power requirements, 10
- Product code, 5, 57

R

- Reliability, 6
- Repair, 33
- Returns, 8, 9

S

- Set point, 5
- Setup, 11
- Specifications
 - electrical, 44
 - environmental, 44
 - performance, 43
 - physical, 45

T

Troubleshooting, 35

U

Unpacking, 9

 checklist, 10

 opening, 9

V

Valve

 override, 28

Z

Zero, 26