

**MKS Type VoDM-B
Vapor on Demand
Module**

Designed for Use with Water Only

Copyright © 2002 by MKS Instruments, Inc.

All rights reserved. No part of this work may be reproduced or transmitted in any form or by any means, electronic or mechanical, including photocopying and recording, or by any information storage or retrieval system, except as may be expressly permitted in writing by MKS Instruments, Inc.

Printed in the United States of America

Baratron® is a registered trademark of MKS Instruments, Inc., Andover, MA

Swagelok® and VCR are registered trademarks of Swagelok Marketing Co., Solon, OH

Inconel® is a registered trademark of Inco Alloys International, Huntington, WV

This manual is for firmware version: 1.00

Table of Contents

Vapor Flow Controller Safety Information.....	1
Symbols Used in This Instruction Manual.....	1
Symbols Found on the Unit	2
Safety Procedures and Precautions	3
Sicherheitshinweise für den Massenflussregler für Dampfförmige Medien.....	5
In dieser Betriebsanleitung vorkommende Symbole	5
Erklärung der am Gerät angebrachten Symbole	6
Sicherheitsvorschriften und Vorsichtsmaßnahmen.....	7
Informations relatives à la sécurité pour le contrôleur de débit de vapeur	9
Symboles utilisés dans ce manuel d'utilisation	9
Symboles apparaissant sur l'unité	10
Mesures de sécurité et précautions	11
Medidas de seguridad del controlador de flujo de vapor	13
Símbolos usados en este manual de instrucciones	13
Símbolos hallados en la unidad	14
Procedimientos y precauciones de seguridad	15
Chapter One: General Information	17
Introduction.....	17
How This Manual is Organized	18
Customer Support	18
Chapter Two: Installation	19
How To Unpack the Type VoDM Unit	19
Unpacking Checklist.....	19
Interface Cables	20
Generic Shielded Cable Guidelines	20
Product Location and Requirements.....	22
Operating Environmental Requirements	22
Safety Conditions.....	22

Power requirements :	22
Water Supply	22
Other Considerations	22
Setup	23
Dimensions	23
Operating Temperature	24
Liquid Source.....	24
Outlet Line	25
Mounting Instructions.....	25
How To Select a New Input Voltage Setting	27
Connectors	28
Analog I/O Connector.....	29
AC Power Connector.....	31
Start Up.....	32
Preparation:.....	32
Warm Up Time	32
Chapter Three: Overview.....	33
Safety Considerations	33
Power Module.....	33
Main Enclosure	33
Functional Description.....	34
Auto Balance Feature.....	34
LEDs	35
Status LED.....	35
Error LED	36
Valve Open/Close Feature	37
Labels.....	38
Serial Number Label.....	38
Chapter Four: Operation	39
General Information.....	39
How To Set the Flow Set Point.....	39
How To Control the Operation of the Valves.....	40
How To Open the Inlet Valve.....	40

How To Close the Inlet Valve	40
How To Open the Outlet Valve	41
How To Close the Outlet Valve.....	41
How To Set the Valve Control to the Flow Set Point.....	41
How To Use the Auto Balance Feature	42
Chapter Five: Maintenance	43
General Information.....	43
Storage	43
Cleaning.....	43
How To Replace the Fuses	44
Appendix A: Product Specifications.....	45
Electrical Specifications	45
Performance Specifications	45
Physical Specifications	46
Environmental Specifications.....	46
Appendix B: Model Code Explanation.....	47
Model Code	47
Product Type.....	47
Full Scale Range and Flow Unit.....	47
Fittings	47
Valve Type.....	47
Connector.....	48
Seals.....	48
Index	49

List of Figures and Tables

Figures

Figure 1: Preferred Method To Ground an Overall Metal Braided Shielded Cable	21
Figure 2: Alternate Method To Ground an Overall Metal Braided Shielded Cable	21
Figure 3: Top View of the VoDM Unit	23
Figure 4: Front View of the VoDM Unit	23
Figure 5: Side Views of the VoDM Unit	24
Figure 6: Typical System Configuration.....	26
Figure 7: Components of the Power Module	27
Figure 8: Front Panel Component Identification	28
Figure 9: Location of the LEDs in the Rear of the VoDM Unit	35
Figure 10: Serial Number Label	38

Tables

Table 1: Definition of Symbols Found on the Unit	2
Tabelle 2: Bedeutung der am Gerät angebrachten Symbole.....	6
Tableau 3: Définition des symboles apparaissant sur l'unité	10
Tabla 4: Definición de los símbolos hallados en la unidad.....	14
Table 5: Analog I/O Connector Pinout	29
Table 6: System Status LED Indications	35
Table 7: Description of the LED Error Codes	36
Table 8: Valve Control Pins on the Analog I/O Connector	37
Table 9: Fuse Types	44

Vapor Flow Controller Safety Information

Symbols Used in This Instruction Manual

Definitions of WARNING, CAUTION, and NOTE messages used throughout the manual.

Warning



The **WARNING** sign denotes a hazard to personnel. It calls attention to a procedure, practice, condition, or the like, which, if not correctly performed or adhered to, could result in injury to personnel.

Caution



The **CAUTION** sign denotes a hazard to equipment. It calls attention to an operating procedure, practice, or the like, which, if not correctly performed or adhered to, could result in damage to or destruction of all or part of the product.

Note



The **NOTE** sign denotes important information. It calls attention to a procedure, practice, condition, or the like, which is essential to highlight.

Symbols Found on the Unit

The following table describes symbols that may be found on the unit.















Definition of Symbols Found on the Unit			
 On (Supply) IEC 417, No.5007	 Off (Supply) IEC 417, No.5008	 Earth (ground) IEC 417, No.5017	 Protective earth (ground) IEC 417, No.5019
 Frame or chassis IEC 417, No.5020	 Equipotentiality IEC 417, No.5021	 Direct current IEC 417, No.5031	 Alternating current IEC 417, No.5032
 Both direct and alternating current IEC 417, No.5033-a	 Class II equipment IEC 417, No.5172-a	 Three phase alternating current IEC 617-2 No.020206	
 Caution, refer to accompanying documents ISO 3864, No.B.3.1	 Caution, risk of electric shock ISO 3864, No.B.3.6	 Caution, hot surface IEC 417, No.5041	

Table 1: Definition of Symbols Found on the Unit

Safety Procedures and Precautions

The following general safety precautions must be observed during all phases of operation of this instrument. Failure to comply with these precautions or with specific warnings elsewhere in this manual violates safety standards of intended use of the instrument and may impair the protection provided by the equipment. MKS Instruments, Inc. assumes no liability for the customer's failure to comply with these requirements.

DO NOT SUBSTITUTE PARTS OR MODIFY INSTRUMENT

Do not install substitute parts or perform any unauthorized modification to the instrument. Return the instrument to an MKS Calibration and Service Center for service and repair to ensure that all safety features are maintained.

SERVICE BY QUALIFIED PERSONNEL ONLY

Operating personnel must not attempt component replacement and internal adjustments. Any service must be made by qualified service personnel only.

USE CAUTION WHEN OPERATING WITH HAZARDOUS MATERIALS

If hazardous materials are used, observe the proper safety precautions, completely purge the instrument when necessary, and ensure that the material used is compatible with the wetted materials in this product, including any sealing materials.

PURGE THE INSTRUMENT

After installing the unit, or before removing it from a system, purge the unit completely with a clean, dry gas to eliminate all traces of the previously used flow material.

USE PROPER PROCEDURES WHEN PURGING

This instrument must be purged under a ventilation hood, and gloves must be worn for protection.

DO NOT OPERATE IN AN EXPLOSIVE ENVIRONMENT

To avoid explosion, do not operate this product in an explosive environment unless it has been specifically certified for such operation.

USE PROPER FITTINGS AND TIGHTENING PROCEDURES

All instrument fittings must be consistent with instrument specifications, and compatible with the intended use of the instrument. Assemble and tighten fittings according to manufacturer's directions.

CHECK FOR LEAK-TIGHT FITTINGS

Carefully check all vacuum component connections to ensure leak-tight installation.

OPERATE AT SAFE INLET PRESSURES

Never operate at pressures higher than the rated maximum pressure (refer to the product specifications for the maximum allowable pressure).

INSTALL A SUITABLE BURST DISC

When operating from a pressurized gas source, install a suitable burst disc in the vacuum system to prevent system explosion should the system pressure rise.

KEEP THE UNIT FREE OF CONTAMINANTS

Do not allow contaminants to enter the unit before or during use. Contamination such as dust, dirt, lint, glass chips, and metal chips may permanently damage the unit or contaminate the process.

ALLOW THE UNIT TO WARM UP

If the unit is used to control dangerous gases, they should not be applied before the unit has completely warmed up. Use a positive shutoff valve to ensure that no erroneous flow can occur during warm up.

Sicherheitshinweise für den Massenflussregler für Dampfförmige Medien

In dieser Betriebsanleitung vorkommende Symbole

Bedeutung der mit WARNUNG!, VORSICHT! und HINWEIS gekennzeichneten Absätze in dieser Betriebsanleitung.

Warnung!



Das Symbol **WARNUNG!** weist auf eine Gefahr für das Bedienpersonal hin. Es macht auf einen Arbeitsablauf, eine Arbeitsweise, einen Zustand oder eine sonstige Gegebenheit aufmerksam, deren unsachgemäße Ausführung bzw. ungenügende Berücksichtigung zu Verletzungen führen kann.

Vorsicht!



Das Symbol **VORSICHT!** weist auf eine Gefahr für das Gerät hin. Es macht auf einen Bedienungsablauf, eine Arbeitsweise oder eine sonstige Gegebenheit aufmerksam, deren unsachgemäße Ausführung bzw. ungenügende Berücksichtigung zu einer Beschädigung oder Zerstörung des Gerätes oder von Teilen des Gerätes führen kann.

Hinweis



Das Symbol **HINWEIS** macht auf wichtige Informationen bezüglich eines Arbeitsablaufs, einer Arbeitsweise, eines Zustands oder einer sonstige Gegebenheit aufmerksam.

Erklärung der am Gerät angebrachten Symbole

Nachstehender Tabelle sind die Bedeutungen der Symbole zu entnehmen, die am Gerät angebracht sein können.















Bedeutung der am Gerät angebrachten Symbole			
			
Ein (Energie) IEC 417, No.5007	Aus (Energie) IEC 417, No.5008	Erdanschluß IEC 417, No.5017	Schutzleiteranschluß IEC 417, No.5019
			
Masseanschluß IEC 417, No.5020	Aquipotential- anschluß IEC 417, No.5021	Gleichstrom IEC 417, No.5031	Wechselstrom IEC 417, No.5032
			
Gleich- oder Wechselstrom IEC 417, No.5033-a	Durchgängige doppelte oder verstärkte Isolierung IEC 417, No.5172-a	Dreileiter- Wechselstrom (Drehstrom) IEC 617-2, No.020206	
			
Warnung vor einer Gefahrenstelle (Achtung, Dokumen- tation beachten) ISO 3864, No.B.3.1	Warnung vor gefährlicher elektrischer Spannung ISO 3864, No.B.3.6	Höhere Temperatur an leicht zugänglichen Teilen IEC 417, No.5041	

Tabelle 2: Bedeutung der am Gerät angebrachten Symbole

Sicherheitsvorschriften und Vorsichtsmaßnahmen

Folgende allgemeine Sicherheitsvorschriften sind während allen Betriebsphasen dieses Gerätes zu befolgen. Eine Mißachtung der Sicherheitsvorschriften und sonstiger Warnhinweise in dieser Betriebsanleitung verletzt die für dieses Gerät und seine Bedienung geltenden Sicherheitsstandards, und kann die Schutzvorrichtungen an diesem Gerät wirkungslos machen. MKS Instruments, Inc. haftet nicht für Mißachtung dieser Sicherheitsvorschriften seitens des Kunden.

Niemals Teile austauschen oder Änderungen am Gerät vornehmen!

Ersetzen Sie keine Teile mit baugleichen oder ähnlichen Teilen, und nehmen Sie keine eigenmächtigen Änderungen am Gerät vor. Schicken Sie das Gerät zwecks Wartung und Reparatur an den MKS-Kalibrierungs- und -Kundendienst ein. Nur so wird sichergestellt, daß alle Schutzvorrichtungen voll funktionsfähig bleiben.

Wartung nur durch qualifizierte Fachleute!

Das Auswechseln von Komponenten und das Vornehmen von internen Einstellungen darf nur von qualifizierten Fachleuten durchgeführt werden, niemals vom Bedienpersonal.

Vorsicht beim Arbeiten mit gefährlichen Stoffen!

Wenn gefährliche Stoffe verwendet werden, muß der Bediener die entsprechenden Sicherheitsvorschriften genauestens einhalten, das Gerät, falls erforderlich, vollständig spülen, sowie sicherstellen, daß der Gefahrstoff die von ihm benetzten, am Gerät verwendeten Materialien, insbesondere Dichtungen, nicht angreift.

Spülen des Gerätes mit Gas!

Nach dem Installieren oder vor dem Ausbau aus einem System muß das Gerät unter Einsatz eines reinen Trockengases vollständig gespült werden, um alle Rückstände des Vorgängermediums zu entfernen.

Anweisungen zum Spülen des Gerätes

Das Gerät darf nur unter einer Ablufthaube gespült werden. Schutzhandschuhe sind zu tragen.

Gerät nicht zusammen mit explosiven Stoffen, Gasen oder Dämpfen benutzen!

Um der Gefahr einer Explosion vorzubeugen, darf dieses Gerät niemals zusammen mit (oder in der Nähe von) explosiven Stoffen aller Art eingesetzt werden, sofern es nicht ausdrücklich für diesen Zweck zugelassen ist.

Anweisungen zum Installieren der Armaturen!

Alle Anschlußstücke und Armaturenteile müssen mit der Gerätespezifikation übereinstimmen, und mit dem geplanten Einsatz des Gerätes kompatibel sein. Der Einbau, insbesondere das Anziehen und Abdichten, muß gemäß den Anweisungen des Herstellers vorgenommen werden.

Verbindungen auf Undichtigkeiten prüfen!

Überprüfen Sie sorgfältig alle Verbindungen der Vakuumkomponenten auf undichte Stellen.

Gerät nur unter zulässigen Anschlußdrücken betreiben!

Betreiben Sie das Gerät niemals unter Drücken, die den maximal zulässigen Druck (siehe Produktspezifikationen) übersteigen.

Geeignete Berstscheibe installieren!

Wenn mit einer unter Druck stehenden Gasquelle gearbeitet wird, sollte eine geeignete Berstscheibe in das Vakuumsystem installiert werden, um eine Explosionsgefahr aufgrund von steigendem Systemdruck zu vermeiden.

Verunreinigungen im Gerät vermeiden!

Stellen Sie sicher, daß Verunreinigungen jeglicher Art weder vor dem Einsatz noch während des Betriebs in das Instrumenteninnere gelangen können. Staub- und Schmutzpartikel, Glassplitter oder Metallspäne können das Gerät dauerhaft beschädigen oder Prozeß und Meßwerte verfälschen.

Geräteeinheit auf Arbeitstemperatur bringen!

Wird das Gerät zur Flußregelung gefährlicher Gase verwendet, so dürfen diese nur nach Abschluß des Anwärmvorgangs zugeführt werden. Um das versehentliche Fließen von Gas während der Aufheizperiode zu verhindern, sollte ein Absperrventil (normal geschlossen) eingebaut werden.

Informations relatives à la sécurité pour le contrôleur de débit de vapeur

Symboles utilisés dans ce manuel d'utilisation

Définitions des indications AVERTISSEMENT, ATTENTION, et REMARQUE utilisées dans ce manuel.

Avertissement



L'indication **AVERTISSEMENT** signale un danger pour le personnel. Elle attire l'attention sur une procédure, une pratique, une condition, ou toute autre situation présentant un risque d'accident pour le personnel, en cas d'exécution incorrecte ou de non respect des consignes.

Attention



L'indication **ATTENTION** signale un danger pour l'appareil. Elle attire l'attention sur une procédure d'exploitation, une pratique, ou toute autre situation, présentant un risque d'endommagement ou de destruction d'une partie ou de la totalité de l'appareil, en cas d'exécution incorrecte ou de non respect des consignes.

Remarque



L'indication **REMARQUE** signale une information importante. Elle attire l'attention sur une procédure, une pratique, une condition, ou toute autre situation, présentant un intérêt particulier.

Symboles apparaissant sur l'unité

Le tableau suivant décrit les symboles pouvant apparaître sur l'unité.















Définition des symboles apparaissant sur l'unité			
			
Marche (sous tension) IEC 417, No.5007	Arrêt (hors tension) IEC 417, No.5008	Terre (masse) IEC 417, No.5017	Terre de protection (masse) IEC 417, No.5019
			
Masse IEC 417, No.5020	Equipotentialité IEC 417, No.5021	Courant continu IEC 417, No.5031	Courant alternatif IEC 417, No.5032
			
Courant continu et alternatif IEC 417, No.5033-a	Matériel de classe II IEC 417, No.5172-a	Courant alternatif triphase IEC 617-2, No.020206	
			
Attention : se reporter à la documentation ISO 3864, No.B.3.1	Attention : risque de choc électrique ISO 3864, No.B.3.6	Attention : surface brûlante IEC 417, No.5041	

Tableau 3: Définition des symboles apparaissant sur l'unité

Mesures de sécurité et précautions

Prendre les précautions générales de sécurité suivantes pendant toutes les phases d'exploitation de cet appareil. Le non respect des ces précautions ou des avertissements contenus dans ce manuel constitue une violation des normes de sécurité relatives à l'utilisation de l'appareil et peut diminuer la protection fournie par l'appareil. MKS Instruments, Inc. n'assume aucune responsabilité concernant le non respect des consignes par les clients.

PAS DE SUBSTITUTION DE PIÈCES OU DE MODIFICATION DE L'APPAREIL

Ne pas installer des pièces de substitution ou effectuer des modifications non autorisées sur l'appareil. Renvoyer l'appareil à un centre de service et de calibrage MKS pour tout dépannage ou réparation afin de garantir l'intégrité des dispositifs de sécurité.

DÉPANNAGE UNIQUEMENT PAR DU PERSONNEL QUALIFIÉ

Le personnel d'exploitation ne doit pas essayer de remplacer des composants ou de faire des réglages internes. Tout dépannage doit être uniquement effectué par du personnel qualifié.

PRÉCAUTION EN CAS D'UTILISATION AVEC DES PRODUITS DANGEREUX

Si des produits dangereux sont utilisés, prendre les mesures de précaution appropriées, purger complètement l'appareil quand cela est nécessaire, et s'assurer que les produits utilisés sont compatibles avec les composants liquides de l'appareil, y compris les matériaux d'étanchéité.

PURGE DE L'APPAREIL

Après l'installation de l'unité, ou avant son enlèvement d'un système, purger l'unité complètement avec un gaz propre et sec afin d'éliminer toute trace du produit de flux utilisé précédemment.

UTILISATION DES PROCÉDURES APPROPRIÉES POUR LA PURGE

Cet appareil doit être purgé sous une hotte de ventilation, et il faut porter des gants de protection.

PAS D'EXPLOITATION DANS UN ENVIRONNEMENT EXPLOSIF

Pour éviter toute explosion, ne pas utiliser cet appareil dans un environnement explosif, sauf en cas d'homologation spécifique pour une telle exploitation.

UTILISATION D'ÉQUIPEMENTS APPROPRIÉS ET PROCÉDURES DE SERRAGE

Tous les équipements de l'appareil doivent être cohérents avec ses spécifications, et compatibles avec l'utilisation prévue de l'appareil. Assembler et serrer les équipements conformément aux directives du fabricant.

VÉRIFICATION DE L'ÉTANCHÉITÉ DES CONNEXIONS

Vérifier attentivement toutes les connexions des composants pour le vide afin de garantir l'étanchéité de l'installation.

EXPLOITATION AVEC DES PRESSIONS D'ENTRÉE NON DANGEREUSES

Ne jamais utiliser des pressions supérieures à la pression nominale maximum (se reporter aux spécifications de l'unité pour la pression maximum admissible).

INSTALLATION D'UN DISQUE D'ÉCHAPPEMENT ADAPTÉ

En cas d'exploitation avec une source de gaz pressurisé, installer un disque d'échappement adapté dans le système à vide afin d'éviter une explosion du système en cas d'augmentation de la pression.

MAINTIEN DE L'UNITÉ À L'ABRI DES CONTAMINATIONS

Ne pas laisser des produits contaminants pénétrer dans l'unité avant ou pendant l'utilisation. Des produits contaminants tels que des poussières et des fragments de tissu, de glace et de métal peuvent endommager l'unité d'une manière permanente ou contaminer le processus.

RESPECT DU TEMPS D'ÉCHAUFFEMENT

Si l'unité est utilisée pour contrôler des gaz dangereux, ceux-ci ne doivent pas être appliqués avant l'échauffement complet de l'unité. Utiliser une valve de fermeture positive afin de garantir qu'aucun flux ne se produise par erreur pendant l'échauffement.

Medidas de seguridad del controlador de flujo de vapor

Símbolos usados en este manual de instrucciones

Definiciones de los mensajes de advertencia, precaución y de las notas usados en el manual.

Advertencia



El símbolo de advertencia indica la posibilidad de que se produzcan daños personales. **Pone de relieve un procedimiento, práctica, estado, etc. que en caso de no realizarse u observarse correctamente puede causar daños personales.**

Precaución



El símbolo de precaución indica la posibilidad de producir daños al equipo. **Pone de relieve un procedimiento operativo, práctica, estado, etc. que en caso de no realizarse u observarse correctamente puede causar daños o la destrucción total o parcial del equipo.**

Nota



El símbolo de notas indica información de importancia. Este símbolo pone de relieve un procedimiento, práctica o condición cuyo conocimiento es esencial destacar.

Símbolos hallados en la unidad

La tabla siguiente contiene los símbolos que puede hallar en la unidad.















Definición de los símbolos hallados en la unidad			
			
Encendido (alimentación eléctrica) IEC 417, N° 5007	Apagado (alimentación eléctrica) IEC 417, N° 5008	Puesta a tierra IEC 417, N° 5017	Protección a tierra IEC 417, N° 5019
			
Caja o chasis IEC 417, N° 5020	Equipotencialidad IEC 417, N° 5021	Corriente continua IEC 417, N° 5031	Corriente alterna IEC 417, N° 5032
			
Corriente continua y alterna IEC 417, N° 5033-a	Equipo de clase II IEC 417, N° 5172-a	Corriente alterna trifásica IEC 617-2, N° 020206	
			
Precaución. Consulte los documentos adjuntos ISO 3864, N° B.3.1	Precaución. Riesgo de descarga eléctrica ISO 3864, N° B.3.6	Precaución. Superficie caliente IEC 417, N° 5041	

Tabla 4: Definición de los símbolos hallados en la unidad

Procedimientos y precauciones de seguridad

Las precauciones generales de seguridad descritas a continuación deben observarse durante todas las etapas de funcionamiento del instrumento. La falta de cumplimiento de dichas precauciones o de las advertencias específicas a las que se hace referencia en el manual, constituye una violación de las normas de seguridad establecidas para el uso previsto del instrumento y podría anular la protección proporcionada por el equipo. Si el cliente no cumple dichas precauciones y advertencias, MKS Instruments, Inc. no asume responsabilidad legal alguna.

NO UTILICE PIEZAS NO ORIGINALES O MODIFIQUE EL INSTRUMENTO

No instale piezas que no sean originales o modifique el instrumento sin autorización. Para asegurar el correcto funcionamiento de todos los dispositivos de seguridad, envíe el instrumento al Centro de servicio y calibración de MKS toda vez que sea necesario repararlo o efectuar tareas de mantenimiento.

LAS REPARACIONES DEBEN SER EFECTUADAS ÚNICAMENTE POR TÉCNICOS AUTORIZADOS

Los operarios no deben intentar reemplazar los componentes o realizar tareas de ajuste en el interior del instrumento. Las tareas de mantenimiento o reparación deben ser realizadas únicamente por personal autorizado.

TENGA CUIDADO CUANDO TRABAJE CON MATERIALES TÓXICOS

Cuando se utilicen materiales tóxicos, es responsabilidad de los operarios cumplir las medidas de seguridad correspondientes, purgar totalmente el instrumento cuando sea necesario y comprobar que el material utilizado sea compatible con los materiales humedecidos de este producto e inclusive, con los materiales de sellado.

PURGUE EL INSTRUMENTO

Una vez instalada la unidad o antes de retirarla del sistema, purgue completamente la unidad con gas limpio y seco para eliminar todo resto de la sustancia líquida empleada anteriormente.

USE PROCEDIMIENTOS ADECUADOS PARA REALIZAR LA PURGA

El instrumento debe purgarse debajo de una campana de ventilación y deben utilizarse guantes protectores.

NO HAGA FUNCIONAR ESTE INSTRUMENTO EN UN AMBIENTE CON RIESGO DE EXPLOSIONES

Para evitar que se produzcan explosiones, no haga funcionar este producto en un ambiente con riesgo de explosiones, excepto cuando el mismo haya sido certificado específicamente para tal uso.

USE ACCESORIOS ADECUADOS Y REALICE CORRECTAMENTE LOS PROCEDIMIENTOS DE AJUSTE

Todos los accesorios del instrumento deben cumplir las especificaciones del mismo y ser compatibles con el uso que se debe dar al instrumento. Arme y ajuste los accesorios de acuerdo con las instrucciones del fabricante.

COMPRUEBE QUE LAS CONEXIONES SEAN A PRUEBA DE FUGAS

Inspeccione cuidadosamente las conexiones de los componentes de vacío para comprobar que hayan sido instalados a prueba de fugas.

HAGA FUNCIONAR EL INSTRUMENTO CON PRESIONES DE ENTRADA SEGURAS

No haga funcionar nunca el instrumento con presiones superiores a la máxima presión nominal (en las especificaciones del instrumento hallará la presión máxima permitida).

INSTALE UNA CÁPSULA DE SEGURIDAD ADECUADA

Cuando el instrumento funcione con una fuente de gas presurizado, instale una cápsula de seguridad adecuada en el sistema de vacío para evitar que se produzcan explosiones cuando suba la presión del sistema.

MANTENGA LA UNIDAD LIBRE DE CONTAMINANTES

No permita el ingreso de contaminantes en la unidad antes o durante su uso. Los productos contaminantes tales como polvo, suciedad, pelusa, lascas de vidrio o virutas de metal pueden dañar irreparablemente la unidad o contaminar el proceso.

PERMITA QUE LA UNIDAD SE CALIENTE

Si se utiliza la unidad para controlar gases peligrosos, no libere los gases hasta que la unidad termine de calentarse. Use una válvula de cierre positivo para impedir todo flujo no deseado durante el período de calentamiento.

Chapter One: General Information

Introduction

The Type VoDM-B Vapor on Demand Module (VoDM) is designed to vaporize water and control the flow of water vapor without the need for a carrier gas. The VoDM unit is available in two models:

- The VoDMB13CR1BE model can deliver water vapor in a flow rate from 100 standard cubic centimeters per minute (scm) to 1 standard liter per minute (slm).
- The VoDMB33CR1BE model can deliver water vapor in a flow rate from 300 standard cubic centimeters per minute (scm) to 3 standard liters per minute (slm).

The VoDM system consists of three mini-Baratron[®] absolute pressure transducers, a flow nozzle, two high temperature solenoid valves, and a heater block system capable of maintaining temperatures from 30° to 150° C. Connections at the inlet and outlet are made with Swagelok[®] VCR[®] fittings. The VoDM has a normally closed proportional control valve on both the inlet and outlet lines. These valves are *not* positive shutoff valves; some leakage across the valve may occur. If your system cannot tolerate leakage across the valve, install a separate, positive shutoff valve.

The system includes an auto balance feature, which compensates for subtle shifts in the zero reading of the two transducers over time. The auto balance feature removes the difference in reading between the transducers, without the need to pump the system down to base pressure and re-zero each transducer separately.

The VoDM includes a status LED that indicates whether the unit is operating normally or has encountered a fault condition.

How This Manual is Organized

This manual provides instructions on how to set up, install, and operate a Type VoDM unit.

Before installing the Type VoDM unit in a system or operating it, familiarize yourself with all precautionary notes in the *Safety Messages and Procedures* section at the front of this manual. Observe and obey all WARNING and CAUTION notes in the manual.

Chapter One, *General Information*, (this chapter) introduces the product and describes the organization of the manual.

Chapter Two, *Installation*, explains the VoDM's environmental requirements and describes how to mount the instrument in your system.

Chapter Three, *Overview*, gives a brief description of the instrument and its functionality.

Chapter Four, *Operation*, describes how to use the instrument and explains all the functions and features.

Chapter Five, *Maintenance*, lists maintenance required to keep the instrument in good working condition.

Appendix A, *Product Specifications*, lists the specifications of the instrument.

Appendix B, *Model Code Explanation*, explains the model code used to order the instrument.

Customer Support

Standard maintenance and repair services are available at all regional MKS Calibration and Service Centers. In addition, MKS accepts the instruments of other manufacturers for recalibration using the Primary and Transfer Standard calibration equipment located at all of our regional service centers. Should any difficulties arise in the use of your Type VoDM instrument, or to obtain information about companion products MKS offers, contact any authorized MKS Calibration and Service Center. If it is necessary to return the instrument to MKS, please obtain an Equipment Return Authorization (ERA) Number from the MKS Calibration and Service Center before shipping. The ERA Number expedites handling and ensures proper servicing of your instrument.

The inside back cover of this manual lists MKS Calibration and Service Centers.

Warning



All returns to MKS Instruments must be free of harmful, corrosive, radioactive, and toxic materials.

Chapter Two: Installation

How To Unpack the Type VoDM Unit

MKS has carefully packed the Type VoDM unit so that it reaches you in perfect operating order. However, on receipt of the unit, you should check for defects, cracks, broken connectors, etc., to be certain that the VoDM was not damaged during shipment.

Note

Do *not* discard any packing materials until you have completed your inspection and are sure the unit arrived safely.

If you find any damage, notify your carrier and MKS immediately. If it is necessary to return the unit to MKS, obtain an Equipment Return Authorization (ERA) Number from the MKS Service Center before shipping. The inside back cover of this manual lists MKS Calibration and Service Centers.

Caution

Only qualified individuals should perform the installation and any user adjustments. They must comply with all the necessary ESD and handling precautions while installing and adjusting the instrument. Proper handling is essential when working with highly sensitive precision electronic instruments.

Unpacking Checklist

Standard Equipment:

- Type VoDM Unit
- Type VoDM Instruction Manual (this book)

Optional Equipment:

- Electrical Connector Accessories Kit: VoDMA-K1
Includes a mate for the electrical connector
- VoDM Power Supply 15 Foot Extension Cable: CB VoDM-2-15
- D.I. Water Bleed / Recirculation Manifold: 124679-G1

Interface Cables

Follow these guidelines when making the cable to connect the VoDM unit to your system.

Generic Shielded Cable Guidelines

If you choose to manufacture your own cables, follow the guidelines below:

- The cable must have a *braided* metal shield, covering all wires. Aluminum foil and spiral shielding are not as effective; using either may compromise regulatory compliance.
- The connectors must have a metal case that is in direct contact with the cable's shield on the whole circumference of the cable. The inductance of a flying lead or wire from the shield to the connector will seriously degrade the shield's effectiveness. The shield should be grounded to the connector before its internal wires exit.
- With very few exceptions, connectors must make good ground contact to the device's case. A 10-32 threaded insert is provided for this purpose, next to the I/O port (see Figure 5, page 24); connection to it using 12 AWG wire is necessary to achieve CEM Class B limits. "Good contact" is about 0.01 ohms. The ground should surround all wires. Contact to ground at just one point may not suffice.
- It is important that shielded cables with flying leads at one or both ends have the shield grounded at each such end, before the wires exit. Make this ground with absolute minimum length. (A ¼ inch piece of #22 wire may be undesirably long since it has approximately 5 nH of inductance, equivalent to 31 ohms at 1000 MHz). After picking up the braid's ground, keep wires and braid flat against the case. Grounded metal covers are not usually required over terminal strips; if one is required, that is stated in the Declaration of Conformity or in the instruction manual.
- In selecting the appropriate type and wire size for cables, consider:
 - The voltage ratings
 - The cumulative I²R heating of all the conductors (keep them safely cool)
 - The IR drop of the conductors, so that adequate power or signal voltage gets to the device
 - The capacitance and inductance of cables that handle fast signals, such as data lines or stepper motor drive cables
 - Some cables may need internal shielding from specific wires to others; see the instruction manual for details regarding this matter

Example 1: Preferred Method To Ground Cable
(shown on a transducer)

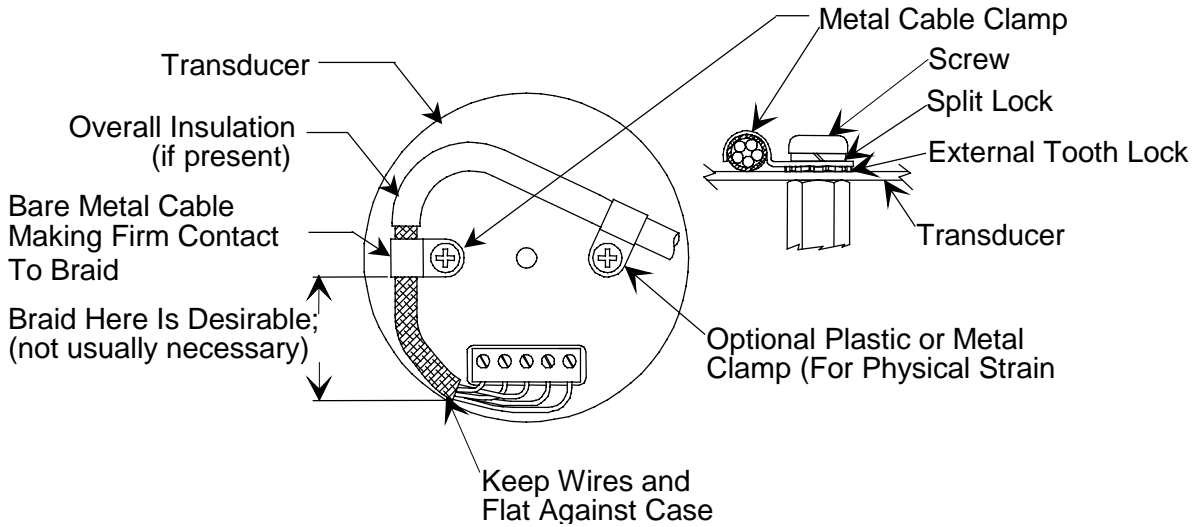

Figure 1: Preferred Method To Ground an Overall Metal Braided Shielded Cable

Example 2: Alternate Method To Ground Cable
(shown on a transducer)

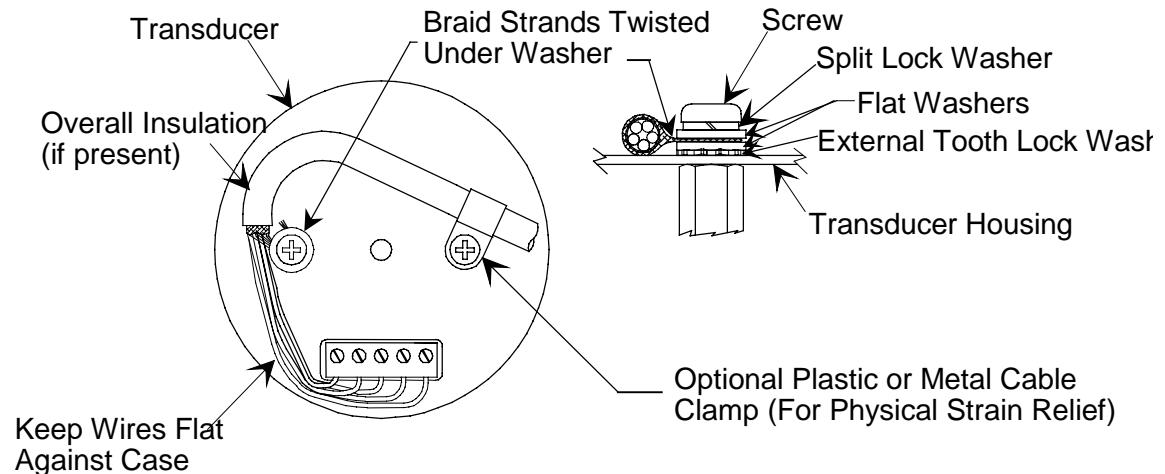

Figure 2: Alternate Method To Ground an Overall Metal Braided Shielded Cable
Use this method when cable clamp is not available

Product Location and Requirements

Operating Environmental Requirements

- Ambient Temperature Range: 15° to 45° C (59° to 113° F)
- Connect the power cord to a grounded outlet.
- Ventilation requirements include sufficient air circulation.

Safety Conditions

The VoDM unit poses no safety risk under the following environmental conditions.

- Altitude: up to 2000 m

Power requirements :

- Controller: ± 15 VDC $\pm 5\%$ @ 1 Amp
For the pressure transducers and valve circuitry
- Power supply: 110 VAC @ 4 Amp; 220VAC @ 2 Amp
Supplies power to the Controller and the heaters with a selection of four fine voltage power input settings, marked 100, 120, 220, and 240 at the input connector. Refer to *How To Select a New Input Voltage Setting*, page 27.

Water Supply

- Water supplied to the VoDM for vaporization must be pressurized to 20~40 psig, de-ionized, and filtered to one micron or less. See *Liquid Source*, page 24.

Caution



Do not allow liquid line pressure to drop below 20 psig, or the liquid water may vaporize too early. Vaporization must not occur before the liquid reaches the inlet of the VoDM unit.

Other Considerations

- Do not mount the VoDM unit in an upside down position, since particulates and condensation may accumulate on the transducer sensing diaphragms and alter the pressure readings. Refer to *Mounting Instructions*, page 25, for more information.
- If your system cannot tolerate some leakage across the control valve, install a separate positive shutoff valve. The normally closed, proportional control valve in the VoDM system is not a positive shutoff valve; some leakage across the valve may occur.
- The VoDM unit is bag packaged in a clean room environment; keep it bagged until installation. It is important to protect the unit's Swagelok VCR fittings since damaged seal surfaces may leak.

Setup

Dimensions

Note  All dimensions are listed in inches with millimeters in parentheses.

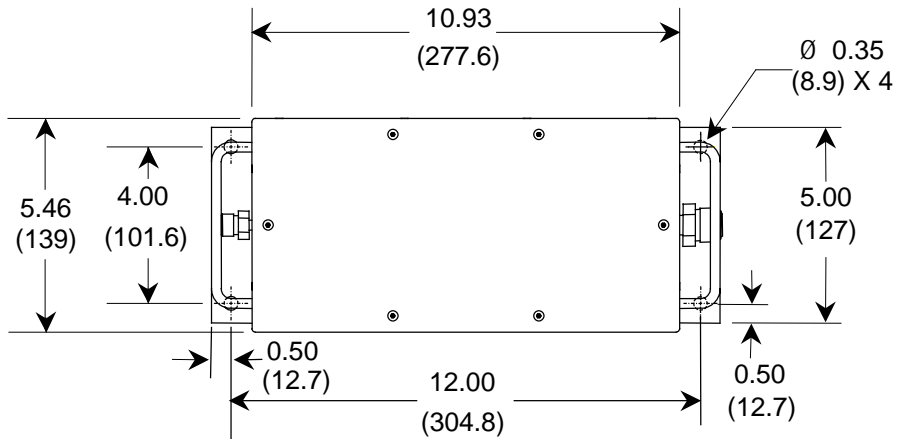

Figure 3: Top View of the VoDM Unit

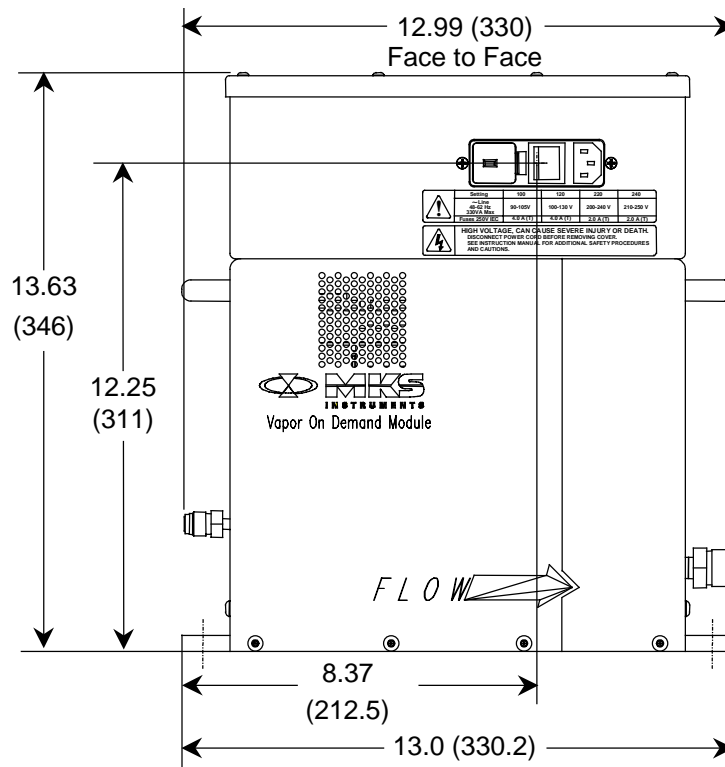

Figure 4: Front View of the VoDM Unit

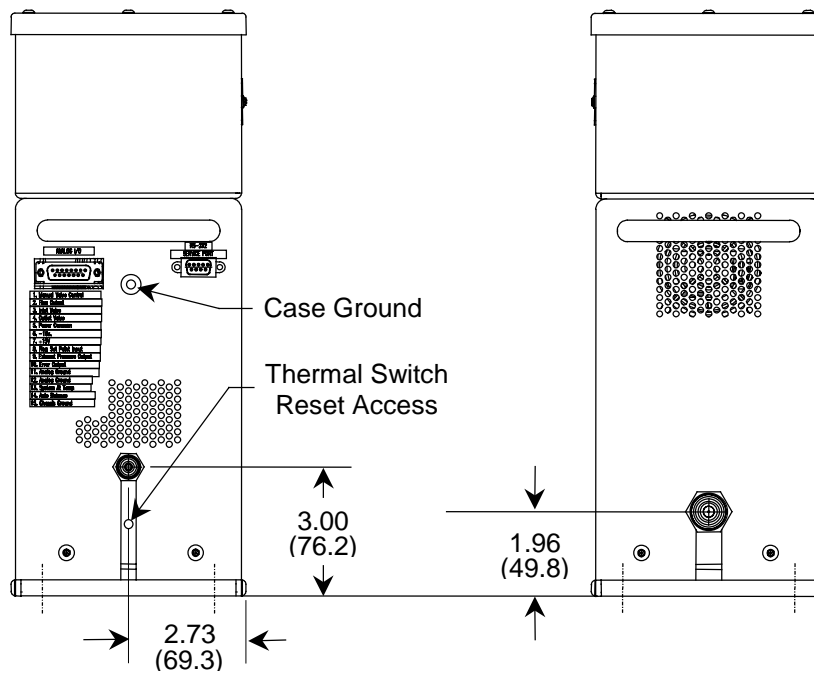

Figure 5: Side Views of the VoDM Unit

Operating Temperature

The system operating temperature must be high enough to prevent condensation of the vaporized water. The operating temperature is factory set at 120° C and ranges from 120° to 160° C during normal operation.

Liquid Source

The liquid water source must:

- Be de-ionized
- Be pressurized to 30 psig \pm 10 psig
- Be filtered to one micron
The filtration prevents plugging of orifices.
- Have very low Total Dissolved Solids (TDS), with:
 - A volume conductivity of not more than 1, and preferably 0.1 micromho/cm

Or

- A volume resistivity of not less than 2, and preferably greater than 18 MOhmcm

It is not necessary to heat the water before it enters the VoDM unit.

Caution



Do not open the inlet valve manually while the liquid water source is attached, since the system may flood.

Outlet Line

The outlet line must be heated to sufficient temperature to maintain the vapor phase and prevent condensation.

Mounting Instructions

The VoDM unit can be mounted in two orientations:

- Horizontally, with the base down. This is the preferred orientation.
- Vertically, with the flow UP.

Do not mount the unit upside down (with the base plate on top), or on its side.

Warning



Read and follow all messages in *Vapor Flow Controller Safety Information*, page 1, BEFORE attempting to install the VoDM unit. Failure to adhere to these messages could result in injury to personnel.

Caution



Ensure that the VoDM controller is not mounted in an upside down position, since particulates and condensation may accumulate on the transducer sensing diaphragm and alter the pressure readings.

Refer to Figure 6, page 26, for a typical system configuration.

To mount the VoDM unit:

1. Ensure that all valves between the unit and the water source are closed.
2. Verify that the input fitting is connected to the water source, and the output fitting to the downstream side.

The front panel of the VoDM unit has an arrow indicating the direction of flow. (Refer to Figure 4, page 23.) The inlet is a 4-VCR male fitting; the outlet is an 8-VCR male fitting.

3. Allow adequate space for the connectors.
Straight, shielded connectors require approximately 3" (76.2 mm). Right angle connectors require approximately 2" (50.8 mm).
4. Place the VoDM unit so the flow is in the direction of the arrow on the side of the controller.
5. Secure the VoDM unit in place.
The base plate of the unit has four clearance holes (0.35 inch diameter) to accommodate mounting screws. Refer to Figure 3, page 23, for the location of the mounting holes.

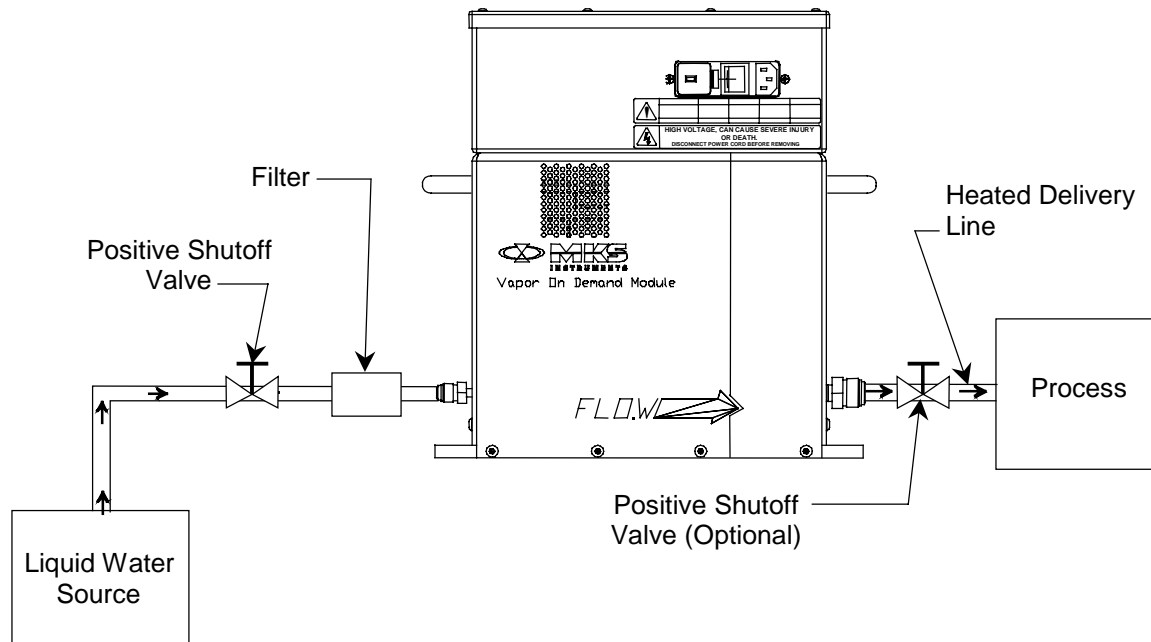

Figure 6: Typical System Configuration

Caution



If your system cannot tolerate some leakage across the control valve, install a separate positive shutoff valve. The normally closed, proportional control valve in the VoDM system is *not* a positive shutoff valve; some leakage across the valve may occur.

Note



The outlet line must be heated to 100° C to prevent condensation of the water vapor. The inlet line does not have to be heated.

How To Select a New Input Voltage Setting

1. Ensure that the power supply power switch is in the off (0) position. Refer to Figure 7 for the location of the power switch.

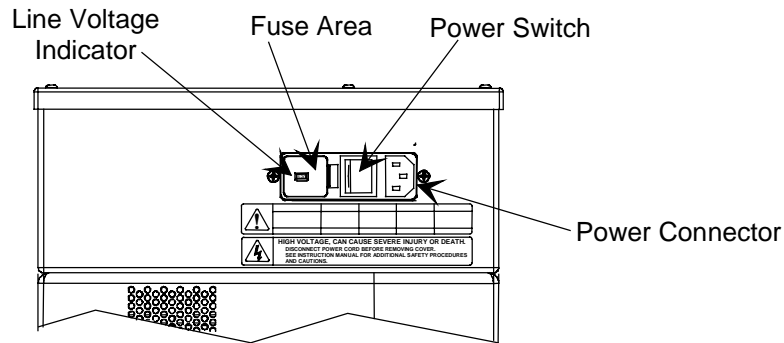



Figure 7: Components of the Power Module

2. Disconnect the power cord from the power supply.

Warning  **The power supply contains lethal voltages. To prevent an electrical shock, disconnect the power cord *BEFORE* proceeding.**

3. Use a small flat head screwdriver to flex the fuse holder clip so that the holder pops up, then remove the holder. Refer to Figure 7 for the location of the fuse holder. Removing the fuse holder exposes the voltage indicator.
4. Using a small pair of long nose pliers, remove the line voltage indicator from the unit.
5. Rotate the line voltage indicator until the proper voltage label shows through the window of the fuse drawer.
6. Replace the line voltage indicator in the power module.
7. Replace the fuses using the correct value for the line voltage indicator. The fuse types are shown in Table 9, page 44. Refer to *How To Replace the Fuses*, page 44, for more information.
8. Insert the fuse drawer in its holder.
9. Connect the AC power cord to the unit's Power connector and an AC power supply.
10. Turn the power switch to the on (1) position.

Connectors

There are two connectors located on the VoDM unit: an Analog I/O and an AC Power connector (refer to Figure 8). The pinout of the Analog I/O connector is listed on the inlet-side panel, as shown in Figure 5, page 24. The pinout for this connector is also listed in Table 5, page 29.

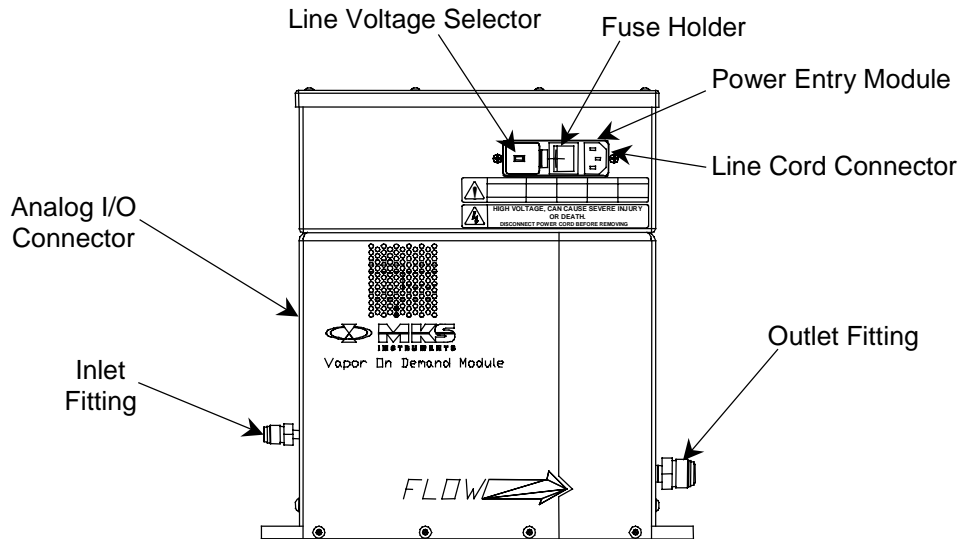

Figure 8: Front Panel Component Identification

Analog I/O Connector

The 15-pin male Type “D” Analog I/O connector provides the pressure output, set point input, and valve control signals.

Analog I/O Connector Pinout	
Pin Number	Assignment
1	Manual Valve Control*
2	Flow Output
3	Inlet Valve*
4	Outlet Valve*
5	Power Common
6	-15 VDC
7	+15 VDC
8	Flow Set Point (0 to 5 VDC)
9	Exhaust Pressure Output
10	Error Output
11	Analog ground
12	Analog ground
13	System at Temperature
14	Auto Balance
15	Chassis Ground
* Refer to <i>Valve Open/Close Feature</i> , page 37, for more information	

Table 5: Analog I/O Connector Pinout

The following is a description of each pin designation:

Pin 1

Manual Valve Control – TTL level input, pin is pulled high (5 VDC) internally. Apply a ground condition to enable valve control of **both** valves

Pin 2

Flow Output – 0-5 VDC flow output signal, representing 0 to 100% of full scale

Pin 3

Inlet Valve – TTL level input, pin is pulled high (5 VDC) internally, valve is opened high, closed low. Activates when Pin 1 is pulled low

Pin 4

Outlet Valve – TTL level input, pin is pulled high (5 VDC) internally, valve is opened high, closed low. Activates when Pin 1 is pulled low

Pin 5

Power Common

Pin 6

-15 VDC supply $\pm 5\%$, 1 Amp maximum, regulation $\pm 1\%$, peak to peak noise less than 0.3% of 15 VDC

Pin 7

+15 VDC supply $\pm 5\%$, 1 Amp maximum, regulation $\pm 1\%$, peak to peak noise less than 0.3% of 15 VDC

Pin 8

Set point input, 0-5 VDC, representing 0 to 100% of full scale

Pin 9

Exhaust Pressure Output – 0-10 VDC signal from P2 transducer, 1000 Torr FS

Pin 10

Error Output – Open Collector Transistor

OK State – 0VDC, can sink 100 mA

Error State – 5 VDC high, can source 1 mA, may also be connected externally to up to 30 VDC Supply

Pin 11

Analog Ground. May also be used for digital grounds

Pin 12

Analog Ground. May also be used for digital grounds

Pin 13

The signal from an open collector transistor indicates when the VoDM system is at temperature. The open collector uses logic high; the signal is low when the system is at temperature and high when the system is not at temperature.

The ratings for the open collector are:

Voltage Output High: 30 V maximum @ 250 mA

Current Output Low: 100 mA maximum @0.8V VCE

Pin 14

Auto Balance – TTL level input, pin is pulled high (5 VDC) internally, high is normal. Auto Balance function activated on low input

Pin 15

Chassis Ground

AC Power Connector

The Power Entry module, located on the front panel of the VoDM unit, contains:

- Line voltage selector
- IEC power line connector
- Power line fuses (2)
- RFI power line filter

Refer to Figure 8, page 28, for the location of each component.

Start Up

Warning



Read and follow all safety messages listed in *Vapor Flow Controller Safety Information*, page 1, **BEFORE** attempting to operate the VoDM unit. Failure to adhere to these messages could result in personal injury.

Preparation:

1. Connect all liquid and gas lines and electrical cables.

Caution



Water should not be present in the liquid lines at this point.

2. Manually open the inlet and outlet valves. Refer to *How To Control the Operation of the Valves*, page 40, for details.
3. Leak check the entire system.
4. Allow the system to warm up for three (3) hours.
Warming the unit with the valves open drives off residuals adsorbed on internal surfaces.

Caution



Monitor the VoDM unit during the warm up process. Should the unit encounter an EPROM failure, the heaters may still turn on and cause the unit to overheat. A mechanical thermal safety switch shuts off power when the unit's temperature exceeds 210° C.

Warm Up Time

The unit requires three (3) hours to warm up. Although the indicated temperature may stabilize at the desired operational temperature within 1 to 2 hours, a full 3 hours is required for the entire unit to stabilize.

During the warm up period the temperature of the VoDM unit may overshoot the set point temperature by a few degrees.

Note



MKS recommends that the instrument be powered at all times. Continuously powering the unit avoids long warmups and reduces thermal stress on sensitive components resulting from temperature cycling. However, if the unit is unused for more than 48 hours, it should be shut down and purged. See *General Information*, page 39.

Chapter Three: Overview

Safety Considerations

The design philosophy for the VoDM unit is to develop a safe product suitable for semiconductor production equipment. The goal is to ease integration of the device without adding cost or complexity, or compromising safety. Original equipment manufacturers (OEMs) should find it easy to add a VoDM unit to a process tool and comply with the various regulatory agencies and specifications in the semiconductor manufacturing field.

The VoDM unit consists of a Power Module and a Main Enclosure.

Power Module

The Power Module is a separate enclosure that handles incoming AC power and delivers 24 Volts AC to the heaters in the Main Enclosure of the VoDM unit. The power inlet is a standard IEC 320 type double pole switch connector module, with integral fusing. Inside the power distribution box, the inlet fixture is insulated with a boot to prevent human contact. Power goes to an isolation transformer that reduces the voltage to 24 Volts AC. All wiring is routed through a DIN rail contact block designed to meet safety standards that include preventing human contact. The wiring is routed to the Main Enclosure of the VoDM unit through a high power connector at the interface between the enclosures. The Power Module and Main Enclosure are fastened together with four bolts, which are not externally accessible. Removing the Power Module from the Main Enclosure disconnects power to the Main Enclosure. An optional 15-foot cable with mating connectors is available for remote placement of the power supply.

Main Enclosure

The Main Enclosure holds the control circuits and mechanisms to control and produce water vapor from liquid. An internal frame holds the circuit boards and solid-state relays. Immersion-type resistance heaters are imbedded in the walls of the flow body. These heaters are controlled in two circuits; each circuit is monitored by an RTD device and has a thermal snap switch in series with the heater elements. The control software only allows the VoDM unit to operate when the temperature is between 120° and 160°C. If the temperature in either circuit rises to between 160° and 200°C, the VoDM reports an over temperature error. If the temperature exceeds 200°C, the thermal snap switch opens the circuit. The 200°C threshold is within specifications for the materials and seals used in the vacuum vessel.

Only 24 Volts AC/DC and lower potentials are present in the Main Enclosure, and a short-circuit current greater than 4 Amps at 115 VAC, or 2 Amps at 230 VAC will blow the Power Supply fuse. This feature prevents damage or injury in case of a water leak. Open areas on each end of the Main Enclosure prevent accumulation of water inside the unit. If the CPU circuit malfunctions (CPU not functioning system shutdown), the failsafe “watchdog” timer expires and automatically attempts to restart the system. The restart sequence includes shutting off the heaters and closing the valves. The heating element remains in the condition it was in before system shutdown.

Functional Description

Operation of the VoDM system is based on flow equations for a compressible gas across an orifice. Two pressure transducers of appropriate range measure these pressures; the CPU calculates the resulting flow rates and generates an output voltage which is scaled to give a 0 to 5 VDC output corresponding to 0 to 100% FS flow of the water vapor. The CPU, using a Proportional-Integral-Derivative (PID) control algorithm, drives its proportioning flow control valve to the correct position for the desired flow rate.

Stability and accuracy of the delivery system depend heavily on the proper integration of the VoDM unit, the power supply, the inlet line and the heated delivery line.

Auto Balance Feature

The VoDM unit includes an auto balance feature that compensates for drift in the readings from the two transducers. All capacitance manometers drift slightly over time; it is necessary to correct for this drift by periodically adjusting the zero value. These adjustments typically require that system pressure first be brought down to base pressure. Requirements for the auto balance function are much less stringent: no flow through the VoDM unit for at least ten seconds and a downstream pressure less than 220 Torr.

The auto balance feature compares the reading from each transducer and applies an offset value to compensate for the difference. Minimizing the difference in readings between the transducers ensures accurate set point flow through the VoDM unit

You can manually initiate the auto balance, or have it always enabled so it becomes active any time the flow is zero and pressure is under 220 Torr. If pin 14 is held low, so auto balance is always enabled, the VoDM unit continuously balances the two transducers as long as those conditions are met, and a 0 set point has been established. Refer to *How To Use the Auto Balance Feature*, page 42.

LEDs

The VoDM unit is equipped with four internal LEDs that indicate power, status, and errors. They are visible through the vent holes in the instrument's rear panel.

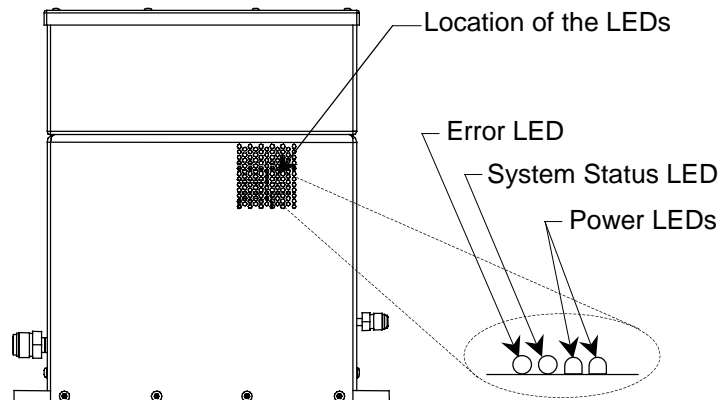

Figure 9: Location of the LEDs in the Rear of the VoDM Unit

The LEDs are unlit when power is off. Two of them turn green when power is applied to the unit.

Status LED

The System Status LED (second from the left) indicates the status of the VoDM unit by its color and blink rate.

- When the VoDM unit is functioning properly and at operating temperature, this LED flashes green, approximately once every two seconds.
- During warm up, while the VoDM unit is below operating temperature, the LED flashes red, approximately once every two seconds.

System Status LED indications and their associated conditions are listed in Table 6.

System Status LED Indications		
LED State	Blink Rate	Meaning
Flashing Green	2 seconds	System functioning normally
Flashing Red	2 seconds	System under temperature*
Solid Green or Red	Not blinking	CPU not functioning [☆]
OFF	Not blinking	CPU not functioning; system powered down
* Flow is disabled when the unit is under temperature ☆ Contact MKS Applications for assistance		

Table 6: System Status LED Indications

Error LED

If there are no error conditions, the Error LED (farthest left) flashes green at two-second intervals.

When the VoDM unit detects an error condition, the Error LED flashes red at a one-second rate to display an error code. The LED flashes three times for error code 3, four times for error code 4, etc. If the unit has encountered multiple errors, the LED flashes the first error code, pauses, and flashes the second error code, and so forth until all errors have been reported. After the last error code, the error LED repeats each code beginning with the first error code.

Note



If the VoDM unit detects an error, it continues to report it even after the error is corrected. You must power the unit off to reset the LED to flashing green. For example, if an over temperature condition is reported, the LED flashes error code 5. After the system temperature returns to normal, the LED continues to flash the error code 5. You must restart the VoDM unit to clear the error code.

Description of the Error LED Codes	
Error Code	Description
3	EEPROM failure [☆]
4	Vapor temperature has gone from operating range to underrange
5	Vapor temperature overrange
6	Flow temperature overrange
7	Baratron transducer delta too large for auto balance
8	Temperature control disabled
15	A/D Converter not responding [☆]
16	RAM failure [☆]
18	Temperature reading is invalid [☆]
[☆] Contact MKS Applications for assistance	

Table 7: Description of the LED Error Codes

Valve Open/Close Feature

The VoDM unit includes two normally closed control valves, one at its inlet and one at its outlet. Either valve can be forced open or closed by overriding the VoDM electronics through pins on the Analog I/O connector. Pin 3 controls the inlet valve; pin 4 controls the outlet valve, and pin 1 determines VoDM valve control.

To close a valve, apply a low signal to its appropriate pin and the valve control pin. When the signal on the valve control pin is allowed to float high, the VoDM unit determines the position of the both the inlet and outlet valves. The VoDM unit determines the valve position by comparing the actual flow with the flow set point signal on pin 8. The signal on pin 8 is overridden if the valve is manually controlled.

Valve Control Pins on the Analog I/O Connector			
Pin 1 (Valve Control)	Pin 3 (Inlet Valve)	Pin 4 (Outlet Valve)	Action
L	L	X	Close inlet valve
L	H	X	Open inlet valve
L	X	L	Close outlet valve
L	X	H	Open outlet valve
H	X	X	VoDM controls valves
Where L = Low; H = High; X = No effect			

Table 8: Valve Control Pins on the Analog I/O Connector

Warning



Never open the inlet valve if a pressurized water supply is connected to the VoDM inlet. This will cause water to flood the VoDM unit. If water is allowed to fill the VoDM unit, you must evacuate the water from the system before resuming normal operation.

Caution



Pulling Pin 1 low overrides the set point on Pin 8 and operates both valves based on the condition of Pins 3 and 4. Set the appropriate conditions of the valves with Pins 3 and 4 before pulling pin 1 low to activate the settings.

Note



The outlet valve must be opened to evacuate the VoDM unit before normal operation.

Labels

Serial Number Label

The serial number label lists the unit's serial and model numbers.



Figure 10: Serial Number Label

Chapter Four: Operation

General Information

Analog control of the VoDM unit is accomplished through the Analog I/O 15-pin D-connector, located on the inlet side panel of the instrument (refer to Figure 5, page 24). Table 5, page 29, shows the Analog I/O connector pinouts.

A full three (3) hours is required for the entire unit to warm up and stabilize. Refer to *Warm Up Time*, page 32, for additional information.

If the system will be idle for more than 48 hours, close the positive shutoff supply valve, open both solenoid valves, and purge the VoDM with dry Nitrogen. Refer to *Storage*, page 43.

How To Set the Flow Set Point

To set the flow set point in sccm, apply a voltage from 0 to 5V to pin 8 on the Analog I/O connector. This voltage range corresponds to 0 to 100% of full flow.

How To Control the Operation of the Valves

The VoDM unit has two control valves, on its inlet and outlet. Pins 1, 3, 4, and 8 on the Analog I/O connector control the operation of the valves. Pin 3 controls the inlet valve; pin 4 controls the outlet valve. Pin 1 controls whether the unit uses direct valve control (set with pin 3 or pin 4) or whether the VoDM unit controls the valve based on the flow set point (set with pin 8).

Refer to *Valve Open/Close Feature*, page 37, for more information.

Caution



Pulling Pin 1 low overrides the set point on Pin 8 and operates both valves based on the condition of Pins 3 and 4. Set the appropriate conditions of the valves with Pins 3 and 4 before pulling pin 1 low to activate the settings.

How To Open the Inlet Valve

Warning



Never open the inlet valve if a pressurized water supply is connected to the VoDM inlet. This will cause water to flood the VoDM unit. If water is allowed to fill the VoDM unit, you must evacuate the water from the system before resuming normal operation. Refer to *Storage*, page 43.

To open the inlet valve:

1. Set Pin 3 HIGH.
2. Set Pin 1 LOW.
Pin 8 set point is overridden.

How To Close the Inlet Valve

To close the inlet valve:

1. Set Pin 3 LOW.
2. Set Pin 1 LOW.
Pin 8 set point is overridden.

How To Open the Outlet Valve

To close the inlet valve:

1. Set Pin 4 HIGH.
2. Set Pin 1 LOW.
Pin 8 set point is overridden.

How To Close the Outlet Valve

To close the outlet valve:

1. Set Pin 4 LOW.
2. Set Pin 1 LOW.
Pin 8 set point is overridden.

How To Set the Valve Control to the Flow Set Point

To control the valve position using the flow set point:

1. Set Pin 1 HIGH.
Pins 3 and 4 are overridden.

How To Use the Auto Balance Feature

The auto balance feature is controlled by pin 14 of the Analog I/O connector (refer to Table 5, page 29).

1. Ensure that there has been no vapor flowing through the VoDM for at least ten seconds.
2. Ensure that the downstream pressure is less than 220 Torr.
3. Apply a low signal to pin 14 on the Analog I/O connector to activate the auto balance feature.

If a low signal is applied constantly to pin 14, the VoDM unit auto balances whenever the conditions described in steps 1 and 2 are met. You can also manually activate the auto balance when the two conditions are met, by applying a low signal to pin 14.

Note

Using the auto balance feature on a regular basis ensures accurate set point flow through the VoDM unit.

Chapter Five: Maintenance

General Information

- Maintain a 1 micron water filter upstream from the VoDM unit.
- Periodically check the cables for wear and inspect the enclosure for visible signs of damage.
- Leak check the VoDM unit once a year to ensure continuous vacuum integrity of all seals.

Storage

If the VoDM unit will be deactivated for a long period:

1. Hold the two solenoid valves open.
2. Purge all water from the unit with dry nitrogen.
3. Cap the inlet and outlet ports with the VCR shipping plugs.

Cleaning

Periodically wipe the unit with a damp cloth.

How To Replace the Fuses

To replace existing fuses or confirm the voltage setting of the controller, refer to Figure 7, page 27, and follow the instructions in this section.

1. Select the proper fuses, referring to Table 9.

Fuse Types		
Line Voltage	Voltage Selector Setting	Fuse Type
90 to 105 VAC @ 48 to 62 Hz 150 VA (max)	100	4.0 A, 250 V
105 to 125 VAC @ 48 to 62 Hz 150 VA (max)	120	4.0 A, 250 V
180 to 225 VAC @ 48 to 62 Hz 150 VA (max)	220	1.6 A, 250 V
225 to 250 VAC @ 48 to 62 Hz 150 VA (max)	240	1.6 A, 250 V

Table 9: Fuse Types

Note



The fuses are IEC rated (where the name plate value is the expected current *carrying* rating) and not UL or CSA rated (where the name plate value is nearly the current *blowing* rating). Use of UL or CSA rated fuses will cause unnecessary blowing at high loads.

2. Disconnect the power cord from the VoDM unit.

Warning



Disconnect the power cord *before* proceeding to prevent electrical shock.

3. Disconnect the Analog I/O cable from the connector on the side of the unit.
4. Disengage the fuse holder by inserting a small flathead screwdriver under one side of the fuse holder, then the other.
The fuse holder slides partway out of the instrument.
5. Carefully slide the fuse holder out and remove the fuse.
6. Insert a new fuse of the correct type into the fuse holder.
7. Slide the fuse holder back into the Power Entry module, and snap it completely into the instrument.
8. Connect the Analog I/O cable and power cord.

Appendix A: Product Specifications

Electrical Specifications

Voltage Range	100 to 250 VAC
Power Requirement	± 15 VDC $\pm 5\%$ @ 1 Amp and either: 120 VAC @ 3.5 Amps or 220 VAC @ 2 Amps
Fuse Ratings 100 VAC, 120 VAC 220 VAC, 240 VAC	4.0A, 250 V 1.6 A, 250 V

Performance Specifications

Flow Accuracy ¹	$\pm 3.0\%$ of full scale
Flow Rate Range	VoDMB13CR1BV: 100 sccm to 1 slm VoDMB33CR1BV: 300 sccm to 3 slm
Flow Repeatability	$\pm 0.2\%$ of full scale
Flow Resolution	0.1% of full scale
Internal Operating Pressure	2000 Torr, maximum
Output Noise	$\pm 1.00\%$ peak-to-peak at full scale
Warm up Time	3 hours

¹Includes controller error, linearity, hysteresis, and repeatability.

Physical Specifications

Attitude Sensitivity	Preferred orientation is horizontal If mounted vertically, flow must be UP Do not mount the unit upside down or on its side
Cable Length, maximum (for signal output)	100 feet
Connectors: AC Power Analog I/O	IEC standard power entry module 15-pin male Type "D"
Dimensions	13.63" H x 13" W x <5.46" D (34.6 cm H x 33.0 cm W x <13.6 cm D)
Fittings: Inlet Outlet	Swagelok 4-VCR male Swagelok 8-VCR male
Mounting Detail	Four Ø0.35" mounting through-holes
Evaporator Set Point Temperature	135° C ±10° C
Vapor Set Point (Flow Body) Temperature	120° C ±5° C
Overpressure Limit	100 psia
Weight	< 32 lbs (14.5 kg)
Wetted Materials	Inconel®, 316L VIM/VAR, Nickel, Titanium, EPDM

Environmental Specifications

Ambient Operating Temperature Range	15° to 45° C (59° to 113° F)
Storage Temperature Range	-20° to 80° C (-4° to 176° F)
Storage Humidity Range	0 to 95% Relative Humidity, non-condensing

Due to continuing research and development activities, these product specifications are subject to change without notice.

Appendix B: Model Code Explanation

Model Code

The model code of your VoDM Vapor Flow Controller designates a unit designed for your application. The serial number label, shown in Figure 10, page 38, lists the model code of the VoDM instrument.

VODMB13CR1BE
or
VoDMB33CR1BE

Product Type

The product type designates the model number of the instrument, which is Type VoDM-B.

Full Scale Range and Flow Unit

The full scale range is:

- 1000 sccm (1 slm) for the VoDMB13CR1BE
- 3000 sccm (3 slm) for the VoDMB33CR1BE

Fittings

The VoDM unit has a Swagelok 4-VCR male fitting on the inlet and an 8-VCR male fitting on the outlet.

Valve Type

The inlet and outlet valves are both normally closed.

Connector

The Analog I/O connector is a 15-pin Type “D” connector.

Seals

The VoDM uses EPDM seals.

Index

A

AC power connector, 31
Accuracy, 34
Analog I/O, 29, 37, 48
At temperature signal, 31
Attitude sensitivity, 22, 46
Auto balance, 17, 31, 34, 42

C

Cable
 extension, 19
 guidelines, 20

Cables
 wire size, 20

Ccable
 extension, 33

Connectors, 28
 AC power, 28
 analog I/O, 28, 39
 Analog I/O, 29, 48
 clearance, 25
 guidelines, 20
 pinouts, 29

Controller, 27

Customer support, 18

D

Dimensions, 23, 24

E

ECU, 27

Error codes, 36

Error LED, 36

F

Filtration, 24

Fittings, 17, 47

Flow direction, 25

Flow set point signal, 39

Full scale range, 17, 47

Fuse information, 44

Fuse, replacing, 27, 44

I

Interface cables, 20

L

Labels
 serial number, 38

LED, 35
 error codes, 36
 status, 17, 35

Liquid source, 24, 25

M

Main enclosure, 33
Manifold, recirculation, 19
Manual organization, 18
Model code, 47
Mounting, 46
Mounting instructions, 25

O

Open collector, 31

Operation

start up, 32

status LED, 35

Optional equipment, 19

Orientation, 22, 46

Outlet line, 25

P

PID control algorithm, 34

Pinout, I/O connector, 29

Power entry module, 27, 31, 33

Power requirements, 22

Power supply, 22, 27, 33

R

Repair, 18

Restart sequence, 33

Returning the product, 18, 19

S

Safety information, 1–16, 33

Seal material, 48

Serial number label, 38

Set point

flow, 39

signal, 39

Setup

mounting instructions, 25

power requirements, 22

Shutoff valve, 17, 22, 26

Specifications, 45

Start up, 32

warm up time, 32

Status LED, 35

System at temperature signal, 31

System configuration, 26

T

Temperature

operating, 24

warm up time, 32

V

Valve

leakage, 17, 22

positive shutoff, 17, 22, 26

type, 47

Valve control

caution, 37, 40

direct, 30, 37, 40

inlet, 30, 40

outlet, 30, 41

set point, 30, 40, 41

Ventilation, 22

Voltage setting, 27

W

Warm up time, 32

Watchdog timer, 33

Water supply, 22, 24

Z

Zero, 17, 34