

## Thyristor-Thyristor Module, 70 Amps

**Features**

- Improved glass passivation for high reliability
- Exceptional stability at high temperatures
- High di/dt and dv/dt capabilities
- Low thermal resistance

**Voltage Ratings** ( $T_A = 25^\circ\text{C}$ , unless otherwise noted)

Type number	Voltage Code	$V_{RRM}$ , Maximum repetitive peak reverse voltage	$V_{RSM}$ , Maximum non-repetitive peak reverse voltage	$V_{DRM}$ , Maximum repetitive peak off-state voltage	$I_{RRM}$ , Maximum reverse leakage current @ $T_{JMAX}$
		(V)	(V)	(V)	(mA)
NTT72 H	200	2000	2100	2000	max. 15
	220	2200	2300	2200	

**Electrical Characteristics** ( $T_A = 25^\circ\text{C}$  unless otherwise noted)

Parameter	Symbol	Values	Units
Maximum average forward current @ $T_J = 85^\circ\text{C}$	$I_{T(AV)}$	70	A
Maximum average RMS forward current	$I_{T(RMS)}$	110	A
Maximum non-repetitive surge current	$I_{TSM}$	1600	A
Maximum $I^2t$ for fusing	$I^2t$	12800	$\text{A}^2\text{s}$
Forward voltage drop	$V_{TM}$	max. 1.8	V
Critical rate of rise of on-state current	di/dt	max. 150	$\text{A}/\mu\text{s}$
Critical rate of rise of off-state voltage	dv/dt	max. 1000	$\text{V}/\mu\text{s}$
Gate current required to trigger	$I_{GT}$	min. 150	mA
Gate voltage required to trigger	$V_{GT}$	min. 3	V
Maximum holding current	$I_H$	150	mA
Maximum latching current	$I_L$	300	mA
Isolation voltage	$V_{ISO}$	4000	V

**Thermal & Mechanical Specifications** ( $T_A = 25^\circ\text{C}$  unless otherwise noted)

Parameter	Symbol	Values	Units
Operating junction temperature range	$T_J$	-40 to +125	$^\circ\text{C}$
Storage temperature	$T_{stg}$	-40 to +125	$^\circ\text{C}$
Thermal resistance, junction to case	$R_{th(jc)}$	0.35	$^\circ\text{C}/\text{W}$
Mounting torque	to heatsink	$5 \pm 15\%$	Nm
	to terminals	$3 \pm 15\%$	
Weight	W	100	g

## Package Outline

(All dimensions in mm)

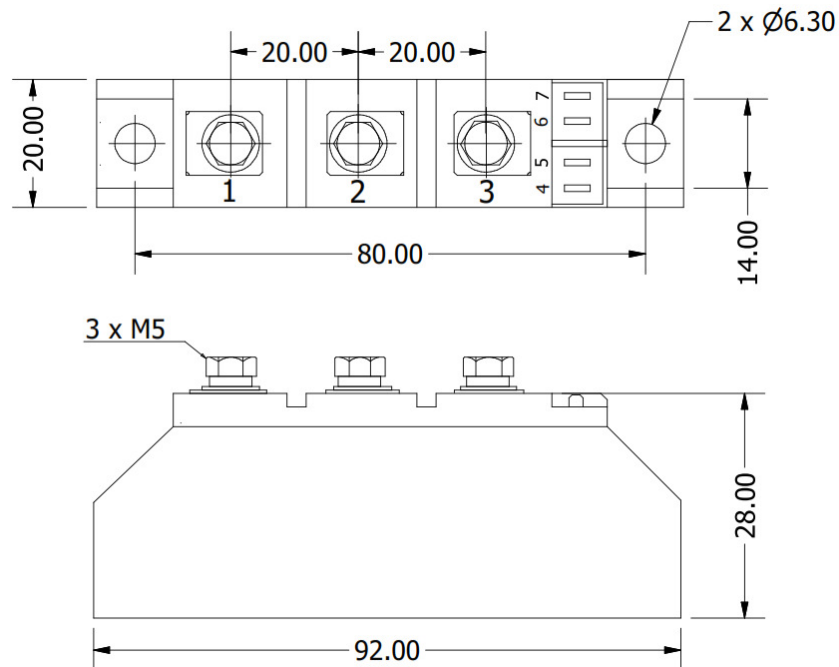

## Circuit Configuration

Circuit Description	Configuration Code	Circuit Drawing
Series Connection (doubler circuit)	N	

## Ordering Table

NTT	72	N	200	H
1	2	3	4	5

1 – Power Module

- > DD = Diode-Diode
- > TD = Thyristor-Diode
- > TT = Thyristor-Thyristor

2 – Current Rating =  $I_{T(AV)}$

3 – Circuit Configuration (see Table)

4 – Voltage Code (see Voltage Ratings table)

5 – High Voltage (2000V, 2200V)