

Three Phase Bridge Rectifier, 100 Amps

Features

- Easy connections
- Excellent power volume ratio
- Insulated type

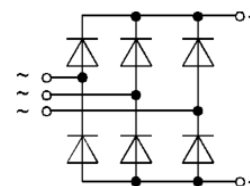

MDS



Voltage Ratings ($T_J = 25^\circ\text{C}$ unless otherwise noted)

Type number	Voltage code	V_{RRM} , Max. repetitive peak reverse voltage (V)	V_{RSM} , Max. non-repetitive peak reverse voltage (V)	I_{RRM} max @ T_J max (mA)
MDS100	80	800	900	10
	100	1000	1100	
	120	1200	1300	
	140	1400	1500	
	160	1600	1700	

Electrical Specifications ($T_J = 25^\circ\text{C}$ unless otherwise noted)

Parameters	Conditions	Symbol	Values	Units
Maximum DC output current	$T_C = 85^\circ\text{C}$	I_{DC}	100	A
Forward surge current (non-repetitive), one cycle	$f = 50$ Hz	I_{FSM}	1150	A
Fusing current		I^2t	6600	A^2s
Maximum forward voltage drop	$I_{FM} = 100\text{A}$, $T_J = 25^\circ\text{C}$	V_{FM}	1.3	V
RMS isolation voltage		V_{ISO}	3000	V

Thermal and Mechanical Specifications ($T_J = 25^\circ\text{C}$ unless otherwise noted)

Parameters	Symbol	Values	Units
Maximum operating junction temperature range	T_J	- 40 to + 150	$^\circ\text{C}$
Maximum storage temperature range	T_{STG}	- 40 to + 150	$^\circ\text{C}$
Maximum thermal resistance, junction to case	$R_{th(J-C)}$	0.16	$^\circ\text{C}/\text{W}$
Mounting torque	to heatsink	$4 \pm 15\%$	Nm
	to terminal	$4 \pm 15\%$	
Approximate weight	W	180	g

Package Outline

(All dimensions in mm)

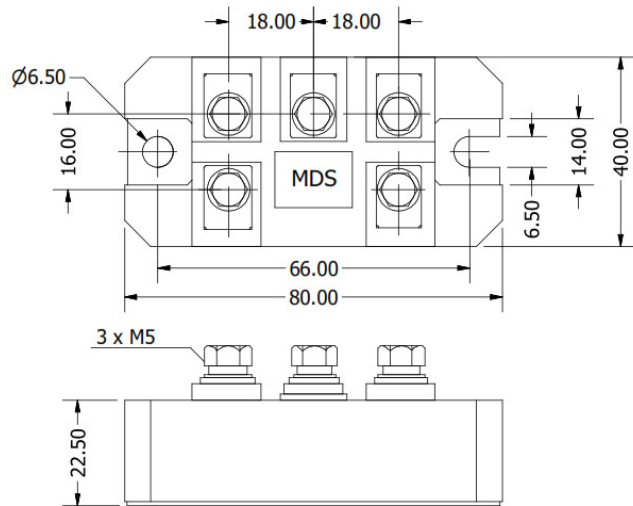

Package Type	D
--------------	---

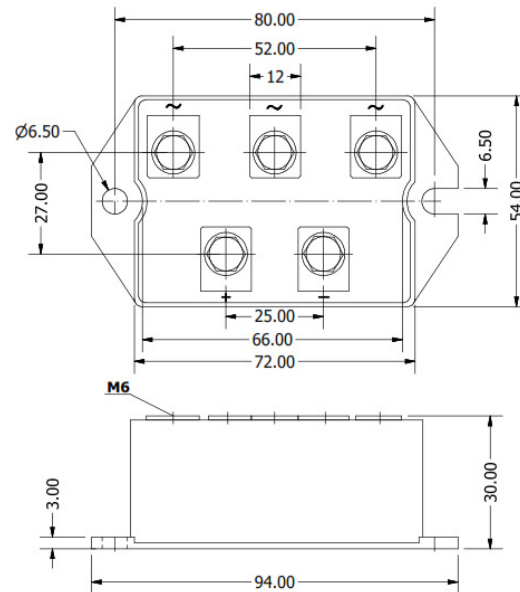

Package Type	S
--------------	---

Ordering Table

MDS	100	/	120
1	2		3

1 – Three-Phase Bridge

2 – Current = I_D

3 – Voltage Code $\times 10 = V_{RRM}$ (See Voltage Ratings Table)