

O-CEH-XXYZXX-X-X-XX-X

Precision Ultra Low Phase Noise OCXO in 36x27 mm “Europack”

Product Data Sheet

Features

- SC-cut crystal
- High Stability
- Low Aging
- Ultra Low Phase Noise Option:
 Standard(L) -140dBc/Hz at 10Hz;
 -169dBc/Hz on the floor
 Premium(P) -145dBc/Hz at 10Hz;
 -170dBc/Hz on the floor
 Ultimate(U) -115 dBc/Hz at 1 Hz
 -146dBc/Hz at 10Hz;
 -170dBc/Hz on the floor
 Extraordinary(E) -120 dBc/Hz at 1 Hz
 -148 dBc/Hz at 10 Hz
 -173 dBc/Hz on the floor
- Sine Wave or HCMOS/TTL output

Applications

- Instrumentation
- GPS
- Telecommunication Systems
- Radar
- COTS/Dual use

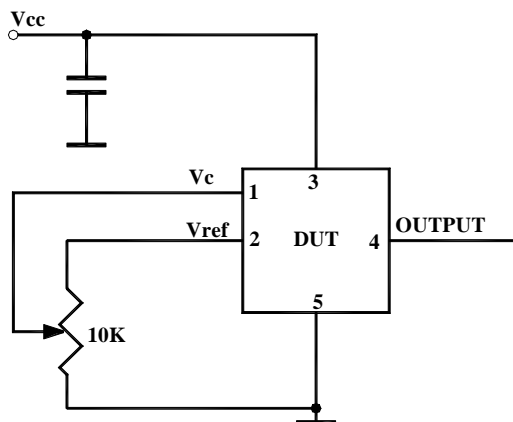
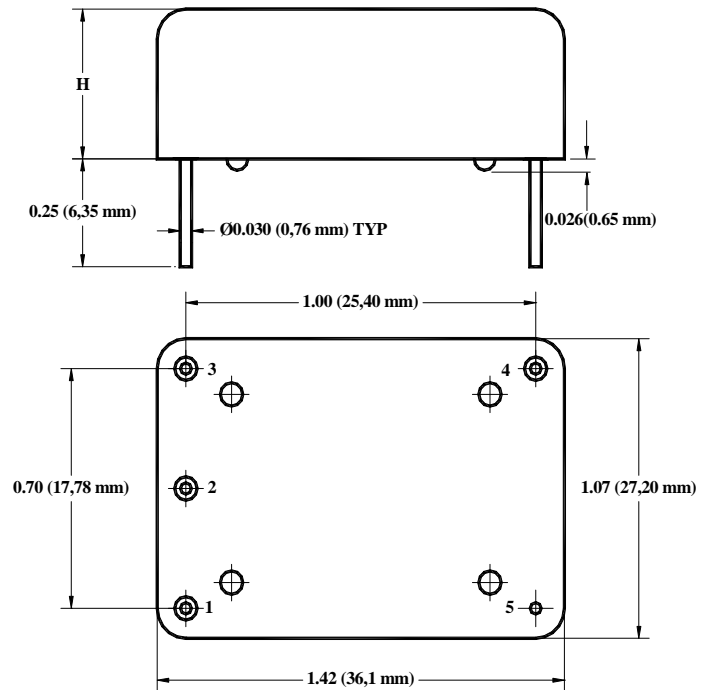

H code	Height, inches, TYP
5	0.5 (12.7 mm)
6	0.63 (16 mm)
7	0.75 (19 mm)

Code 6 is standard unless code 5 is requested. Code 7 is for special requirements.

Parameter	Symb	Condition	Min	Typ	Max	Unit	Note
Absolute Maximum Ratings							
Input Break Down Voltage	Vcc	12 V supply 5 V supply	-0.5 -0.5		13.0 5.5	V	
Storage temper.	Ts		-50		90	°C	
Control Voltage	Vc		-1 -5 -1		5.5 5 11	V	Slope option "P" Slope option "N" Slope option "L"

Electrical (6)

Frequency	F		8	10.000	13	MHz		All parameters for 10 MHz
Frequency stability	$\Delta F/F$	vs. Temp. 4*		20		ppb	See chart below	
		vs. Supply		0.2	0.3	ppb/10% Vcc		
Aging		per day		5E-10			after 30 days	
		per year, first year		1E-7			5E-8 available	
		second year		3E-8				
		10 years		2.5E-7				
Allan Deviation		0.1s		5E-13			Premium version, Option "P"	
		1s		2E-12				
		10s		5E-12				
SSB Phase Noise (achieved after 10 minutes warm-up)		1Hz		-105		dBc/Hz	Standard version, option L	
		10 Hz			-140			
		100 Hz			-155			
		1 KHz			-162			
		10 KHz			-168			
		100 KHz			-169			
		1Hz			-112		Premium version, option P	
		10 Hz			-145			
		100 Hz			-155			
		1 KHz			-162			
		10 KHz			-169			
		100 KHz			-170			
		1Hz			-115		Ultimate version, option U	
		10 Hz			-146			
		100 Hz			-156			
		1 KHz			-163			
10 KHz			-169					
100 KHz			-170					
1Hz			-120	Extraordinary version, option E, available with slope options N or L				
10 Hz			-148					
100 Hz			-160					
1 KHz			-168					
10 KHz			-170					
100 KHz			-173					
Retrace		After 30 minutes			± 10	ppb	24 Hours off 3*	
G-sensitivity		worst direction			± 1.0	ppb/G		
Input Voltage	Vcc		4.75 11.4	5.0 12.0	5.25 12.6	V	See chart below to specify	
Power consumption, Still air	P	steady state, 25°C		1.0	1.4	W	Standard Operating Temperature*	
		steady state, -30°C		1.7	3.2			
		start-up @ -30°C		2.5	3.2			
Spectral Purity		Subharmonics		none		dBc		
		Spurious			-80			
		Harmonics		-35	-30			
Load		10KOhm//15pF (HCMOS/TTL), AC-coupled 50 Ohm (Sine-wave)					Output Code T Output Code S	
Warm-up time	τ	to 0.1ppm accuracy		3	5	minutes		



Output Waveform	HCMOS/TTL compatible or Sinewave						
Output Power			+10	+13		dBm	Output Code S
Logic 1 (CMOS)	Voh		0.7 Vref			V	Output Code T
Logic 0 (CMOS)	Vol				0.1 Vref	V	Output Code T
Control voltage	Vc		0 -4.0 0		Vref 4.0 10.0	V	Slope option "P" Slope option "N" Slope option "L"
Input impedance	Zin	At Vc pin	10			Kohm	
Modulation bandwidth	Fm		DC		1	KHz	Note 8
Reference Voltage	Vref	Vcc = 12V Vcc = 5V		5 or 4.5 4.5		V	N/A with slope options "N" and "L"
Output Impedance		At Vref pin		100		Ohm	
Pull range		from nominal F	±0.4	±0.6		ppm	
Deviation slope		Monotonic, positive Monotonic, negative Monotonic, positive		1.2/Vref -0.15 0.14		ppm/V	Slope option "P" Slope option "N" Slope option "L"
Setability	Vc0	@25°C, Fnom. No internal bias for slope option "L"	Vref/2 ± 0.5 0 ± 0.5 5 ± 0.5			V	Slope option "P" 3* Slope option "N" Slope option "L"

Notes:

- *. For highest operating temperature higher than 70°C the power consumption will be higher (about 20% for 85°C). Values listed are for test in still air environment, the values will go up while testing in the temperature chamber.
- 3*. Longer storage time, especially at low temperatures, may affect both retrace and setability parameters. It may require few days on power for re-stabilization.
- 4*. Temperature stability is specified in total peak to peak frequency excursion over entire operating range, not in ± from RT measurement. Over-specifying may cause cost increase.
- 5*. Pin 2 is connected to Vref only for Slope Option "P".
- 6. All parameters, unless otherwise specified, are at nominal conditions, ie: T=25°C, Nominal Vcc & Nominal Load.
- 8. Older and stock units may have MBW of 150 Hz Max.

Environmental and Mechanical

Operating temp. range	-30°C to 70°C Standard, Other options – see chart below
Storage Temperature	-50°C to 90°C
Mechanical Shock	Per MIL-STD-202, 30G, 11ms
Vibration	Per MIL-STD-202, 5G to 2000 Hz
Soldering Conditions	260°C for 10s Max leads only

Electrical Connections

Pin Out	Pin #1-Vc ; Pin#2 – Vref or N/C (5*); Pin #3 – Vcc; Pin #4- Output ; Pin #5- GND;
---------	---



Creating a Part Number

O - C E H
OCXO

Conventional Power Package Code
 E 5 pin 36x27mm

Height code per dwg

Supply Voltage

Code	Specification
0	5V ± 5%
F	12V ± 5%

Output

Code	Specification
T	CMOS/TTL
S	Sinewave

Temperature Stability 4*

Code	Specification
17	1x10 ⁻⁷
58	5x10 ⁻⁸
28	2x10 ⁻⁸
18	1x10 ⁻⁸
YZ	Yx10 ^{-Z}

Temperature Range

Code	In 5°C steps 7*
First letter	Lowest temperature from A = -40°C
Second letter	Highest temperature to Z = 85°C
Examples	
IS	0°C to 50°C
GU	-10°C to 60°C
EW	-20°C to 70°C

XX - X FREQ

Environmental

Code	Specification
L	Contains a level of lead that is in excess of RoHS directive and is not designed for reflow
R	RoHS compliant, not designed for reflow

Aging

Insert Value per day times 1E-10	
Examples	
5	5E-10 = 0.5 ppb/day
10	1E-9 = 1 ppb/day

Phase Noise (See Table)

Code	Specification
L	Standard
P	Premium
U	Ultimate
E	Extraordinary

Deviation slope

Code	Specification
P	Positive, 0 to Vref
N	Negative, -4 to 4V
L	Positive, 0 to 10 V

Not all combinations are available. Consult Factory.

7*Temperature Code Table

Letter	Temp °C	Letter	Temp °C	Letter	Temp °C	Letter	Temp °C	Letter	Temp °C	Letter	Temp °C
A	-40	F	-15	K	10	P	35	U	60	Z	85
B	-35	G	-10	L	15	Q	40	V	65		
C	-30	H	-5	M	20	R	45	W	70		
D	-25	I	0	N	25	S	50	X	75		
E	-20	J	5	O	30	T	55	Y	80		

