

O-C2GXSXXYY-X-XX-X

Precision SC-cut OCXO in 20x20mm Gull Wing Package

Product Data Sheet

Features

- SC-cut crystal
- High Stability (from 5 ppb)
- Low Aging (5×10^{-10} /day)
- Very Low Phase Noise (-135 dBc/Hz @ 10 Hz)

Applications

- Instrumentation
- Telecommunication Systems
- Data Communications
- GPS
- COTS/Dual use

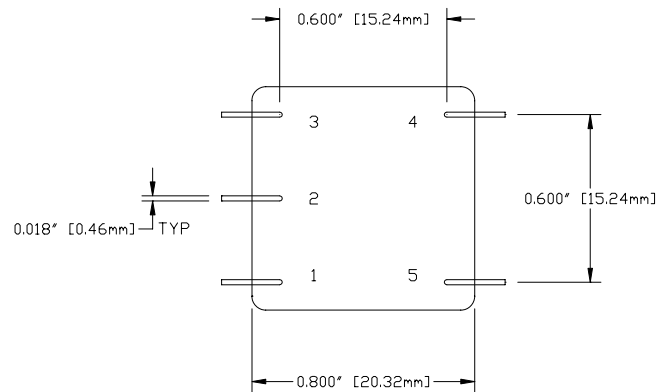
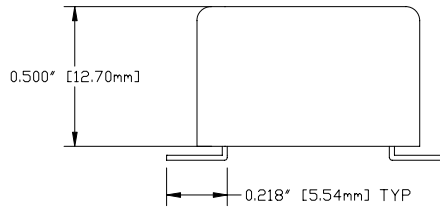

All Dimensions are in inches [mm]

PRELIMINARY

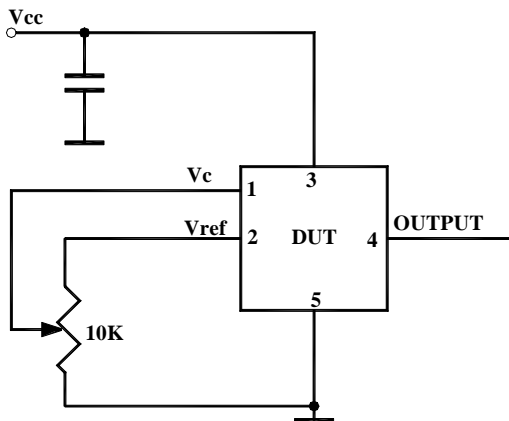

O-C2GX SXXYY-X-XX-X

Parameter	Symb	Condition	Min	Typ	Max	Unit	Note
-----------	------	-----------	-----	-----	-----	------	------

Absolute Maximum Ratings

Input Break Down Voltage	V _{cc}		-0.5		13.0	V	V _{cc} = 12 V
			-0.5		5.5		V _{cc} = 5 V
Storage temper.	T _s		-40		85	°C	
Control Voltage	V _c		-1		12	V	

Electrical (3)

Frequency	F		8.0	10.000	20.000	MHz		
Frequency stability	ΔF/F	vs. Temp., total excursion		10		ppb	Peak-to-peak See chart below	
		vs. Supply		1	2	ppb/5% V _{cc}		
Aging		per day per year, first year 10 years		5E-10 1E-7	3.5E-7		after 30 days 5E-8 available1*	
Allan Deviation		.1s to 1s		5E-12				
SSB Phase Noise		1Hz		-105	-100	dBc/Hz	2*	
		10 Hz		-140	-135			
		100 Hz		-156	-155			
		1 KHz		-163	-162			
		10 KHz		-169	-168			
		100 KHz		-170	-169			
Retrace		After 30 minutes			±10	ppb	24 hrs off	
G-sensitivity		worst direction			±1.0	ppb/G		
Input Voltage	V _{cc}		4.75 11.4	5.0 12.0	5.25 12.6	V	See chart below to specify	
Power consumption	P	steady state, 25°C steady state, -30°C start-up @ -30°C		0.7 1.5 2.5	1.0 3.2	W	Standard Operating Temperature, for Op Temp. 85 °C ad 20% Still air for all	
Spectral Purity		Subharmonics Spurious Harmonics		none -35	-80 -30	dBc		
Load		Internally AC coupled 50 Ohm						
Warm-up time	τ	to 0.1ppm accuracy		3	5	minutes		
Output Power	P _{out}	Into 50 Ohm	7	10				
Control voltage	V _c		0 0		10 4.5	V	Option "L" Option "P"	
Reference Voltage	V _{ref}			4.5		V	Option "P"	
Pull range		from nominal F	±0.6 ±0.4	±0.8 ±0.6		ppm	Option "L" Option "P"	
Deviation slope		Monotonic, posit.		0.16 0.27		ppm/V	Option "L" Option "P"	
Input impedance	Z _{in}	At V _c pin	10			KOhm		
Modulation bandwidth	F _m		DC		1	KHz	Note 4	
Setability	V _{c0}	@25°C, F _{nom} .	4.5 2.0	5.0 2.25	5.5 2.5	V	Op. "L", No internal bias Option "P"	
Initial Calibration		@25°C			±100	ppb		

All parameters for 10 MHz

Environmental and Mechanical

Operating temp. range	0°C to 70°C Standard, Other options – see chart below
Mechanical Shock	Per MIL-STD-202, 30G, 11ms
Vibration	Per MIL-STD-202, 5G to 2000 Hz
Soldering Conditions	260°C for 10s Max leads only

Electrical Connections

Pin Out	Pin #1—V _c ; Pin#2 – V _{ref} or N/C; Pin #3 – V _{cc} ; Pin #4 – Output; Pin #5 - GND
----------------	---

O-C2GX SXXYY-X-XX-X

Notes:

1. Aging rates are proportional to the operating frequency. Pull range will be adjusted accordingly to provide for lifetime possibility to set on frequency
2. Close to the carrier phase noise deteriorates with increase in frequency.
3. All parameters, unless otherwise specified, are at nominal conditions, ie: T=25°C, Nominal Vcc & Nominal Load.
4. Older and stock units may have MBW of 150Hz Max.

Creating a Part Number

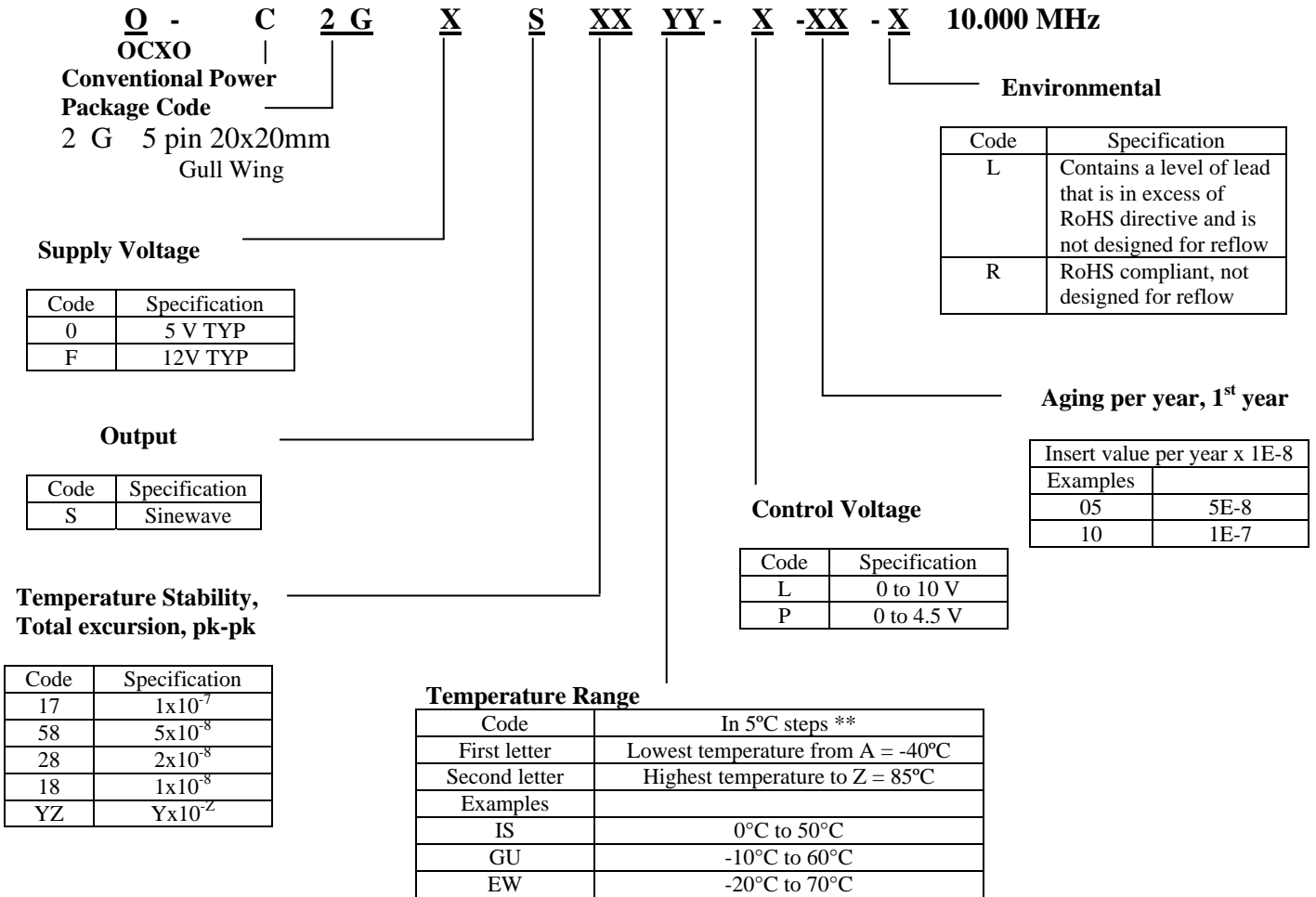

****Temperature Code Table**

Letter	Temp °C	Letter	Temp °C	Letter	Temp °C	Letter	Temp °C	Letter	Temp °C	Letter	Temp °C
A	-40	F	-15	K	10	P	35	U	60	Z	85
B	-35	G	-10	L	15	Q	40	V	65		
C	-30	H	-5	M	20	R	45	W	70		
D	-25	I	0	N	25	S	50	X	75		
E	-20	J	5	O	30	T	55	Y	80		