

M3-LS Linear Smart Stage

All-in-one USB micro stage

- **All-in-one smart module:** no separate electronics
 - Runs directly from USB adapter
 - USB, I²C or SPI interface
- **Small size:** less than 29 x 20 x 10 mm
- **High resolution:** 0.5 μm
- **Absolute encoding:** no homing
- **Long stroke:** 6 mm
- **Low power use:** 3.3 V DC input, < 0.75 W when moving
- **High repeatability** and low runout

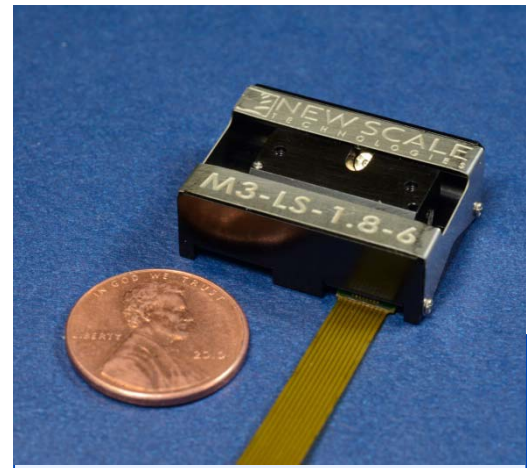

The M3-LS Linear Smart Stage is an ultra-compact positioning stage with high resolution, low power use and absolute encoding. All electronics are built into the stage for simple system integration. Control the stage using high-level motion commands via USB, I²C or SPI interface.

Unmatched precision, stability and ease of use

The M3-LS Linear Smart Stage is a direct-drive, high-precision micro stage built for fast, simple integration into miniature OEM systems. All drive electronics are integrated right into the compact stage housing – no external board needed!

The piezo-driven stage has 0.5 μm resolution for precise, repeatable positioning of optics, probes, sensors and more. **Absolute encoding** removes the need to home the stage on power-up, eliminating errors and disruptions in processes and experiments.

The unique linear slide **has uniform and very low friction**, even under high direct loads and side loads. Six ball bearings in a kinematic “v” guide-way eliminate cage creep and friction spike problems common in other micro stages.

The M3-LS has high stiffness and lateral stability, no backlash, and less than 10 μm runout over its full travel range.

Direct input via USB, I²C or SPI

The stage accepts simple high-level motion commands via standard serial interface. Use the USB adapter to power and control multiple stages from a single New Scale Pathway™ software screen. Use the intuitive script generator to easily create command sequences for automated operations.

The M3-LS stage can also be driven directly from your system processor via standard I²C or SPI interface.

Low power for hand-held systems

The M3-LS Linear Smart Stage needs only 3.3 V DC and uses less than 0.75 W typical when moving. It can be powered by USB or standard batteries. The integrated piezo motor holds position without using power. The internal electronics can be switched to sleep mode for extreme low-power applications.

APPLICATIONS

- Hand-held and mobile instruments
- Battery-powered instruments
- Portable medical devices
- Miniature microscopes
- Spectroscopy
- Micro assembly
- Biomedical probing & sampling
- High-resolution tuning systems
- Targeting systems
- UAV/UGV controls and optics
- Miniature camera systems

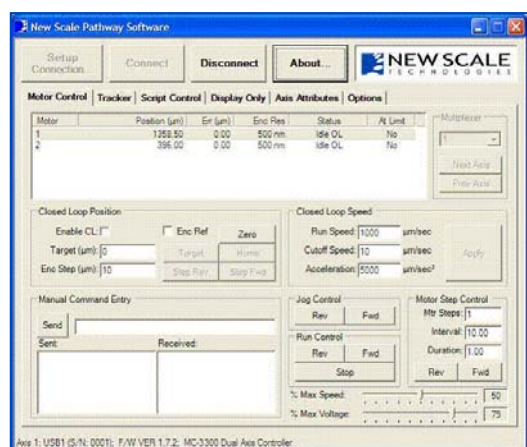

New Scale Pathway™ software with easy-to-use graphical interface. Control multiple smart stages from one PC screen, or develop your own code using the intuitive scripting tool.

Specifications

M3-LS Linear Smart Stage specifications	
MODEL	M3-LS-1.8-6
Stroke	6 mm
Dimensions	29 x 20 x 9.5 mm
Mass of Smart Stage	8.4 grams
Moving mass (vertical) (note 1)	≤ 10 grams recommended
Moving mass (horizontal) (note 1)	≤ 20 grams (offset < 10 mm) recommended
Force (operating)	0.2 N
Speed (at operating force)	5 mm/s
Closed-loop performance	
Resolution	0.5 μm with absolute encoding
Bi-directional repeatability	< 5 μm
Accuracy	< 20 μm
Input Power	3.3 V DC < 0.75 W typical at 5 mm/s, closed-loop (2 W max.)
Mechanical stage	
Static parallelism	< 30 μm
Runout	< 10 μm
Pitch and yaw	< 1 mrad
Absolute maximum load	10 N
Environment	
Relative humidity	< 70%
Operating temperature (note 2)	-30 °C to +70 °C
Storage temperature	-40 °C to +80 °C
Lifetime (note 3)	>10 million random moves while not exceeding 1.2 km total travel. See note 3.
Drive electronics	Integrated into the smart stage
Control interface	Via USB adapter from PC or directly to I ² C or SPI serial interface

Note 1: Higher mass is possible but will affect performance and lifetime.

Note 2: Speed and force reduced at lower temperatures within the range.

Note 3: Corresponds to 10 million moves with an average random move of 120 μm. Lifetime depends on the application and use case. Please consult the factory to discuss your specific system design.

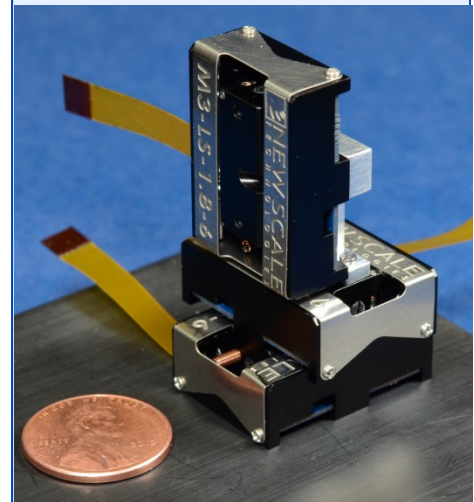
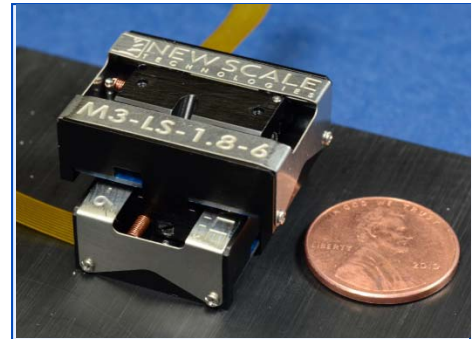

Multi-axis systems: Create miniature X-Y or X-Y-Z smart stages using two or three M3-LS Linear Smart Stages.

M3 smart module platform

The M3-LS Linear Smart Stage is built on New Scale's M3 micro-mechatronic "smart module" platform, integrating a patented piezoelectric SQUIGGLE[®] micro motor, precision mechanical guide system, position sensor, microprocessor, and drive electronics into one tiny package.

Eliminating the need for external controllers, M3 smart modules offer the smallest system size and easiest integration into OEM systems. They operate on 3.3 V DC input, accept high-level motion commands, and hold position with power off.

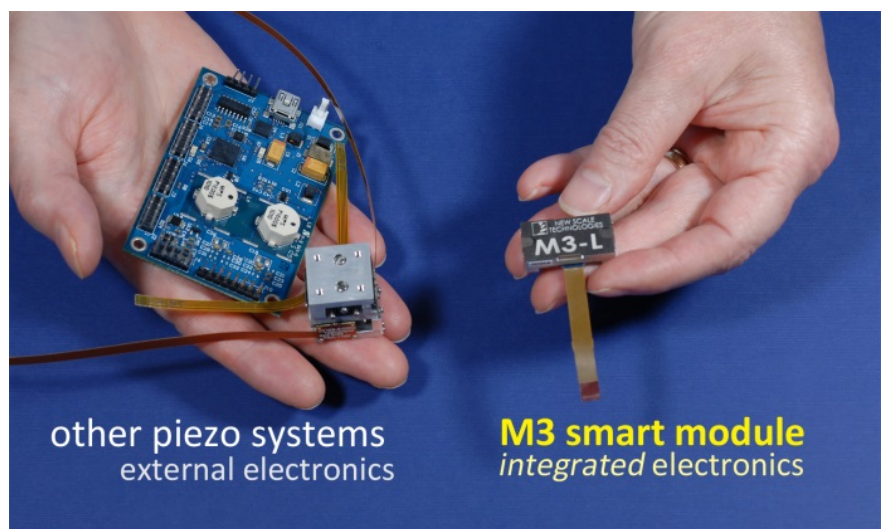

M3-LS-1.8-6 Linear Smart Stage

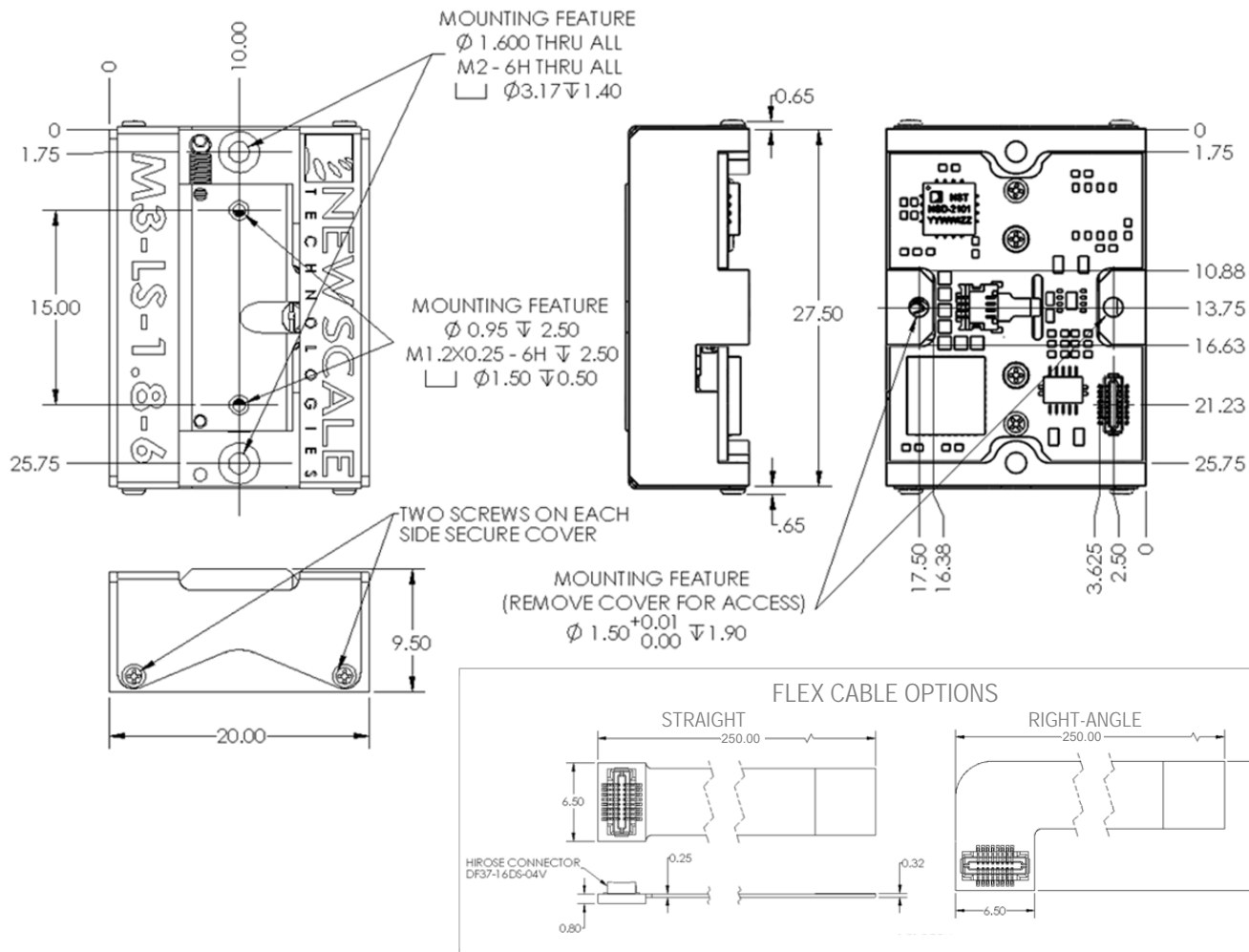

M3-LS-1.8-6 X-Y configuration

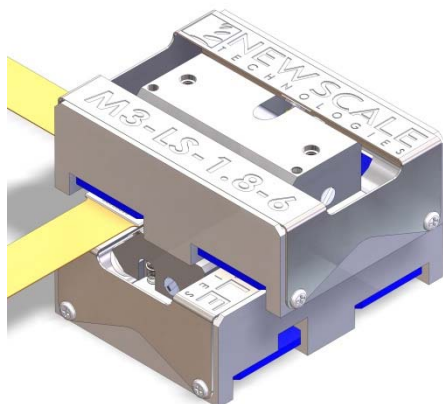

M3-LS-1.8-6 X-Y-Z configuration

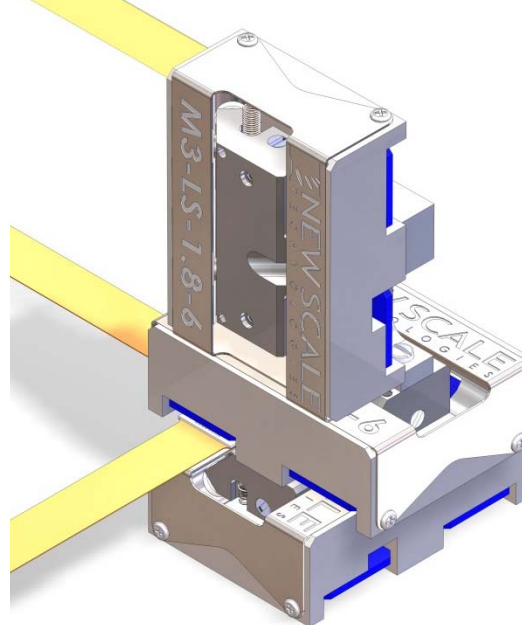

M3-LS for electrophysiology

With its high resolution, repeatability and lateral stability, the M3-LS makes an ideal backlash-free motorized micro drive for electrode positioning in chronic recording. The EP-clamp-6.35 pipette holder clamp facilitates easy removal and replacement of the pipette holder in the recording chamber. Low EMI ensures non-interference with electrode recording.

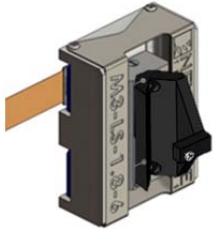

EP-clamp-6.35

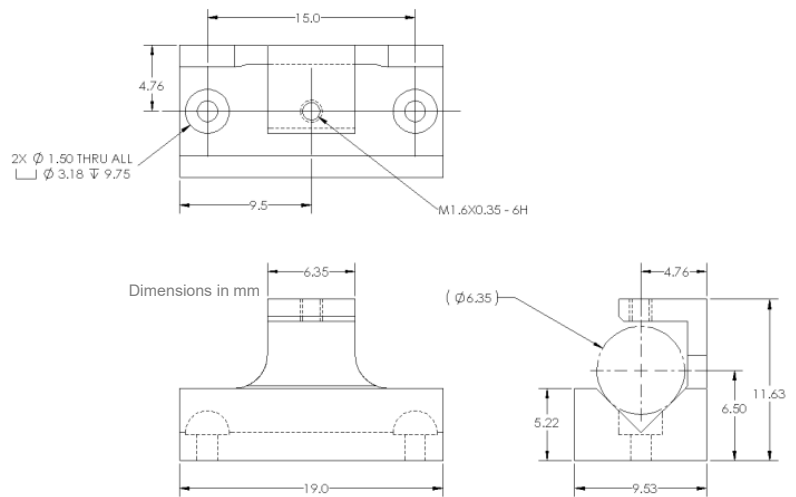

Developer's Kits

M3-LS developer's kits provide easy evaluation and prototyping of one-axis M3-LS Linear Smart Stage systems. Developer's kits are available from New Scale and select reps and distributors.

Contact New Scale regarding additional stages, brackets and flex cables for use with the developer's kit to create 2-axis and 3-axis systems, or to inquire about volume pricing or customization of M3-LS smart stage systems.

Developer's Kit DK-M3-LS-1.8-6

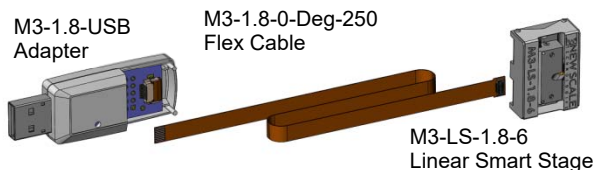

Ordering information

Developer's Kit	Description
DK- M3-LS-1.8-6	M3-LS-1.8 Developer's Kit with 6 mm travel <ul style="list-style-type: none"> One M3-LS-1.8-6 Linear Smart Stage One M3-1.8-USB Adapter M3-1.8-0-Deg-250 straight flex cable, 250 mm long M3-1.8-90-Deg-250 angled flex cable, 250 mm long New Scale Pathway™ Software on separate USB Mounting hardware kit
Additional Components	Description
M3-LS-1.8-6	Linear Smart Stage with 6 mm travel Stage, no cables
M3-1.8-0-Deg-250	Flex cable for M3-LS stage Straight, 250 mm length
M3-1.8-90-Deg-250	Flex cable for M3-LS stage Right angle at one end, 250 mm length
M3-1.8-Y-Bracket	Bracket for Y-axis smart stage Affixes Y-axis smart stage to X-axis smart stage
M3-1.8-Z-Bracket	Bracket for Z-axis smart stage Affixes Z-axis smart stage to X- or Y-axis smart stage
EP-clamp-6.35	Pipette holder clamp Suitable for pipette holders with body dia. 0.25" (6.35mm) e.g. models 67944x from A.M. Systems

Additional information

Visit the website to download STEP files, the integration guide and command and control reference guide for M3-LS Linear Smart Stages: <http://www.newscaletech.com/downloads/software-cad-manuals.php> (registration required).