

# Continuous Auto Focus for Next Generation Phone Cameras

D. A. Henderson, Q. Xu and D. Piazza  
New Scale Technologies, Inc., Victor, NY 14564, USA  
[Dhenderson@newscaltech.com](mailto:Dhenderson@newscaltech.com)

Today nearly two billion mobile phones have digital cameras and an additional 800 million cameras are shipped each year. Recent emphasis on “smart phones” has created the need for faster focus for more rapid picture taking and continuous auto focus (CAF) for clearer video capture. The UTAF™ actuator module uses a unique piezoelectric ultrasonic motor and module design to achieve all CAF requirements. “Ultra Thin Auto Focus” technology integrates: a piezo motor, drive IC, digital Hall position sensor IC, low-friction preload mechanism, precise lens guide, and advanced Smart Step™ algorithm. These critical CAF actuator module specifications are achieved: size less than 8.5 X 8.5 X 4 mm, lens movement from close-up (macro) to distant (infinity) of 300 μm, 30 μm steps in less than 10 msec, acoustic noise less than 35 dBA, power less than 10 mW and lens tilt less than 0.1 degree.

Keywords: piezoelectric, ultrasonic, motor, phone camera, auto focus, optical zoom

## Introduction

In 2010 more than two billion people have a digital camera in their mobile phone and an additional 800 million cameras are shipped each year. Continuous pressure has been applied in the last decade to reduce camera cost, complexity and size while at the same time increasing image quality. These goals are in constant tension but have produced remarkable cameras that fit in the smallest and thinnest mobile phones.

Recent emphasis is on faster focus for more rapid picture taking and continuous auto focus (CAF) for clearer video capture.

The auto focus market today is dominated by voice coil motors (VCM) technology but this technology is struggling to achieve the CAF requirements due to high power, slow stepping times and the high tilt and fragile construction of flexure-spring lens suspension system. A typical step and settle time for a VCM is 20 msec while using 200 mW of power and producing 0.3 degrees of tilt.

New Scale Technologies, Inc has developed the patent-pending UTAF™ “ultra thin auto focus” actuator module to meet the most demanding CAF requirements in mobile phone cameras. The module is shown in Figure 1 and integrates a unique piezo motor, smart driver IC, digital Hall position sensor IC, low-friction preload mechanism, precise lens guide, and advanced Smart Step™ algorithm.

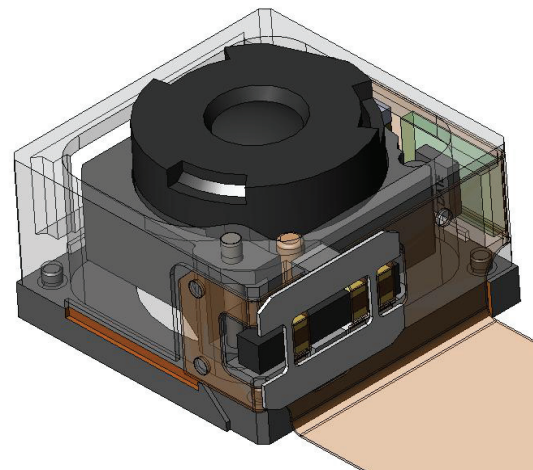

*Fig. 1: UTAF Actuator Module*

UTAF Actuator Module Parameters	Value
Width X Length	8.5 X 8.5 mm
Height	3.8 mm
Lens Diameter	M-6 or M-6.5
Optical Format	1/3"
Stroke	300 μm
Lens Mass	0.25 grams
Speed	< 10 mm/sec
Resolution	< 1 μm
CAF Power	10 mW
Lens Tilt	+/- 0.1 degrees
Step Time for 30 μm	< 10 msec
Motor	Piezo/Ultrasonic
Driver IC	NSD2101
Position Sensor IC	AS5510



**Fig.2:** UTAF Motor and NSD2101 Driver IC on a push pin.

### UTAF Motor

The ultrasonic motor is manufactured under license by EPCOS a division of TDK-EPC in Deutschlandsberg, Austria [www.epcos.com](http://www.epcos.com) and is a single ceramic beam that vibrates at its first bending mode in two orthogonal planes. The piezo motor is shown in Figure 2 and has an integrated multi-element structure that is produced using multi-layer co-fired hard PZT. The beam dimensions are only 4.5 X 0.7 X 0.82 mm. This motor requires a 2 phase drive and operates directly from a battery voltage as low as 2.3 volts. No voltage boost is required! The operation is “semi-resonant” as shown in Figure 3. The vibration amplitude in the driving direction is reduced which has several advantages; (1) stepping resolution less than 1  $\mu\text{m}$  is easily achieved; (2) velocity of <10 mm/sec produces lower acoustic noise; (3) the 1<sup>st</sup>-bending mode resonant frequency is approximately 110 kHz which is 6 times lower than other piezo motors that operate at a 2<sup>nd</sup> bending mode. By operating at a lower frequency the UTAF motor uses proportionally less power.

The center of the UTAF beam has a cylindrical bump that touches an orthogonal cylinder on the moving lens. The contact force is in the range of 8 grams and the coefficient of friction is about 0.25. When the UTAF motor vibrates the friction driving force generated at the contact point is about 2 grams.

The motor is operated using two electrical waveforms with approximately 90 degree phase

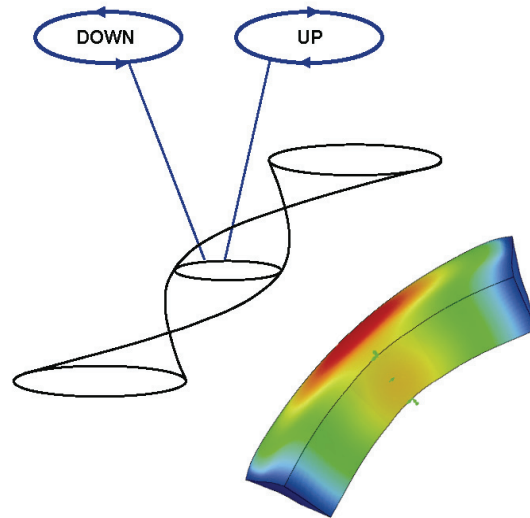

**Fig. 3:** UTAF Vibration Mode Shape

shift. The lens direction is changed by changing the phase so that the vibration mode direction is reversed.

### NSD2101 Driver IC

The NSD2101 driver IC is manufactured by austriamicrosystems. [www.austriamicrosystems.com](http://www.austriamicrosystems.com) It operates directly from the phone battery and provides a complete 2-channel full-bridge drive solution for operating the UTAF motor.

This IC is available in wafer level chip scale package (WLCSP) with solder bumps and the dimensions are only 1.8 X 1.8 X 0.6 mm.

The patent-pending NSD2101 integrates several unique features.

1. The drive frequency is generated on-chip using a VCO. No external clock signal is required.
2. The input voltage range is 2.3 to 5.5 volts. This can come directly from the battery without voltage boost.
3. The drive frequency automatically adjusts to match the motor resonant frequency of approximately 110 kHz. Frequency variations due to manufacturing or temperature changes are automatically eliminated.
4. Two types of speed control are on-chip and are used to reduce the speed and corresponding acoustic noise and also compensate for changes in battery voltage.

- Pulse-Width Modulated “PWM” speed control adjust driving waveforms by adjusting the percentage of ON (duty cycle). The driving waveform approximates a square wave so 50% duty cycle is maximum speed.
- “Hybrid” speed control is used with the full-bridge switches to adjust velocity. The ratio of Full Bridge to Half Bridge motor cycles is adjusted over a fixed period of motor cycles. 100% full-bridge is maximum speed.

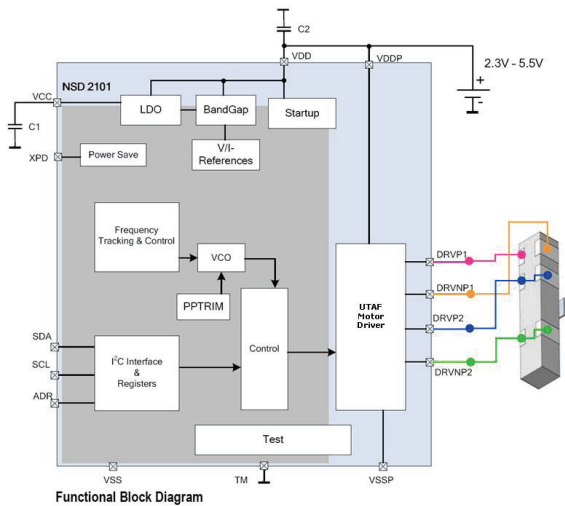

**Fig. 4:** NSD2101 Driver IC, Two-Phase Full-Bridge

5. “Charge Control” optimizes the timing of the full-bridge switching circuit to reduce overall system power more than 30 percent while not changing the motor speed and force.

6. All chip functions are accessed digitally via the I<sup>2</sup>C bus.

### AS5510 Position Sensor

The AS5510 position sensor IC is manufactured by austriamicrosystems and measures the location of the lens. A magnet is attached to the moving lens. The IC is a WLCSP only 1 X 1.3 X 0.6 mm and measures the change in magnetic field that results from lens movement. AS5510 IC that includes the A-D (10 bit) and direct digital output of position via an I<sup>2</sup>C bus.

### UTAF Actuator Module

The UTAF patent-pending module design makes optimum use of the piezo motor precision, speed, force and robustness.

The lens movement is guided by a pin-bushing assembly that is critical to achieving dynamic tilt less than +/- 0.1 degrees. The pin-bushing is located in one corner of the module.

To minimize the friction losses in the pin-bushing the motor drive point (contact point) is located close to the centerline of the pin-bushing. The drive point requires constant force of about 8 grams to produce the required friction and lens driving force. The contact force is generated using permanent magnets that are arranged so that the sums of the magnetic forces are aligned with the motor contact point. Using this method the contact force is created without generating significant reaction forces and friction on the pin-bushing.

The result is a UTAF module that can lift a mass (against gravity) that is at least 3 times bigger than the typical lens mass of 0.25 grams. This safety factor insures a low sensitivity to gravity orientation for the camera system.

### Smart Step Motion Algorithm

Fast, precise and quiet focusing motion is achieved using the Smart Step motion algorithm as shown in Figure 5. This control algorithm must be embedded in the camera’s ISP or base band processor.

The UTAF piezo motor generates lens movement in response to the driving waveforms. One period of the waveforms is a “motor pulse”. The relationship between motor pulses and lens movement is call the “motor scale factor” and can vary significantly due to many factors including location, direction, gravity, friction, and magnetic forces.

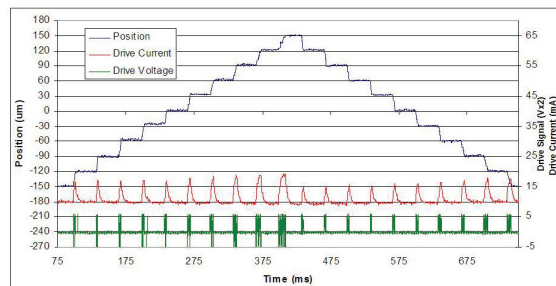

**Fig. 5:** UTAF Fast Position Steps

Smart Step uses the position sensor feedback to continuously measure and calibrate the motor scale factor. Each time a move command is completed the actual movement is used to update the motor scale factor in a calibration matrix. The calibration matrix records motor scale factors for various parameters including: location of lens, direction of lens movement, and size of step. Smart Step enables each move to occur with the minimum number of starts and stops. The speed of movement is also controlled.

The results in Figure 5 show a series of 30 micrometer steps taken every 33 msec. Ten steps are forward and ten steps are in reverse. The movement is shown on top and the stepping time is a small fraction of the 33 msec interval. Below the movement line are charts showing the ten driving waveform voltage and current going into the NSD2101. Both the voltage and current show variation of motor pulses required to move the lens 30 micrometers at different locations and directions. When a new position is reached and motion stops the voltage and current (and power) are zero.

### Speed Control/Acoustic Noise Control

Piezo motors are inherently fast actuators with high acceleration. The nature of piezo motors is to build energy in the resonating structure which is quickly released at the onset of motion. This characteristic makes operation at slower speeds difficult to achieve.

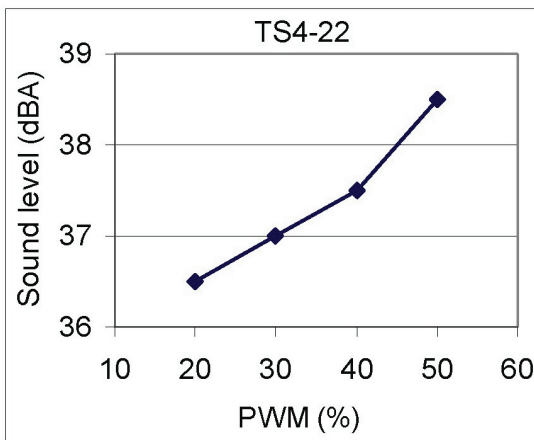

Fig. 6: PWM Speed vs. Acoustic Noise

Figure 6 shows the critical relationship between lens velocity and acoustic noise. Using PWM speed control in the NSD2101 the UTAF lens velocity is reduced and the sound level is also reduced.

Figure 7 shows some typical step and settle plots for a VCM, fast piezo motor and UTAF motor. The

VCM is the quietest motor because the velocity is lower and the settling time is greater than 10 msec. A fast piezo motor can easily move 30  $\mu\text{m}$  in 1 msec. However, this fast movement is noisy because the lens is turned into a speaker. UTAF is shown on the top the speed reduced but the stepping time still much less than 10 msec.

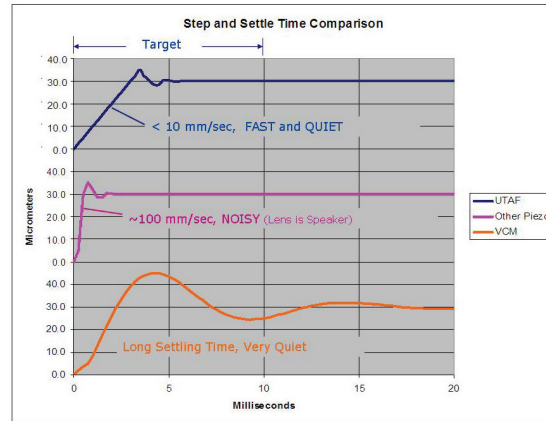

Fig. 7: Focus Steps and Acoustic Noise

### Summary

Innovation in mobile phone cameras continues as consumers demand smaller size and better image quality. The Ultra-Thin Auto Focus (UTAF) module by New Scale Technologies provides a generational improvement in auto focus precision, speed, noise and size when compared to voice coil motors (VCM). UTAF meets the demanding requirements of cameras with greater than 5 mega pixels that require continuous auto focus during video recording.