

**TECHLINE™**  
IMPROVING FLEXIBILITY

LINAK IS YOUR SUPPLIER OF ELECTRICAL ADJUSTMENT SYSTEMS

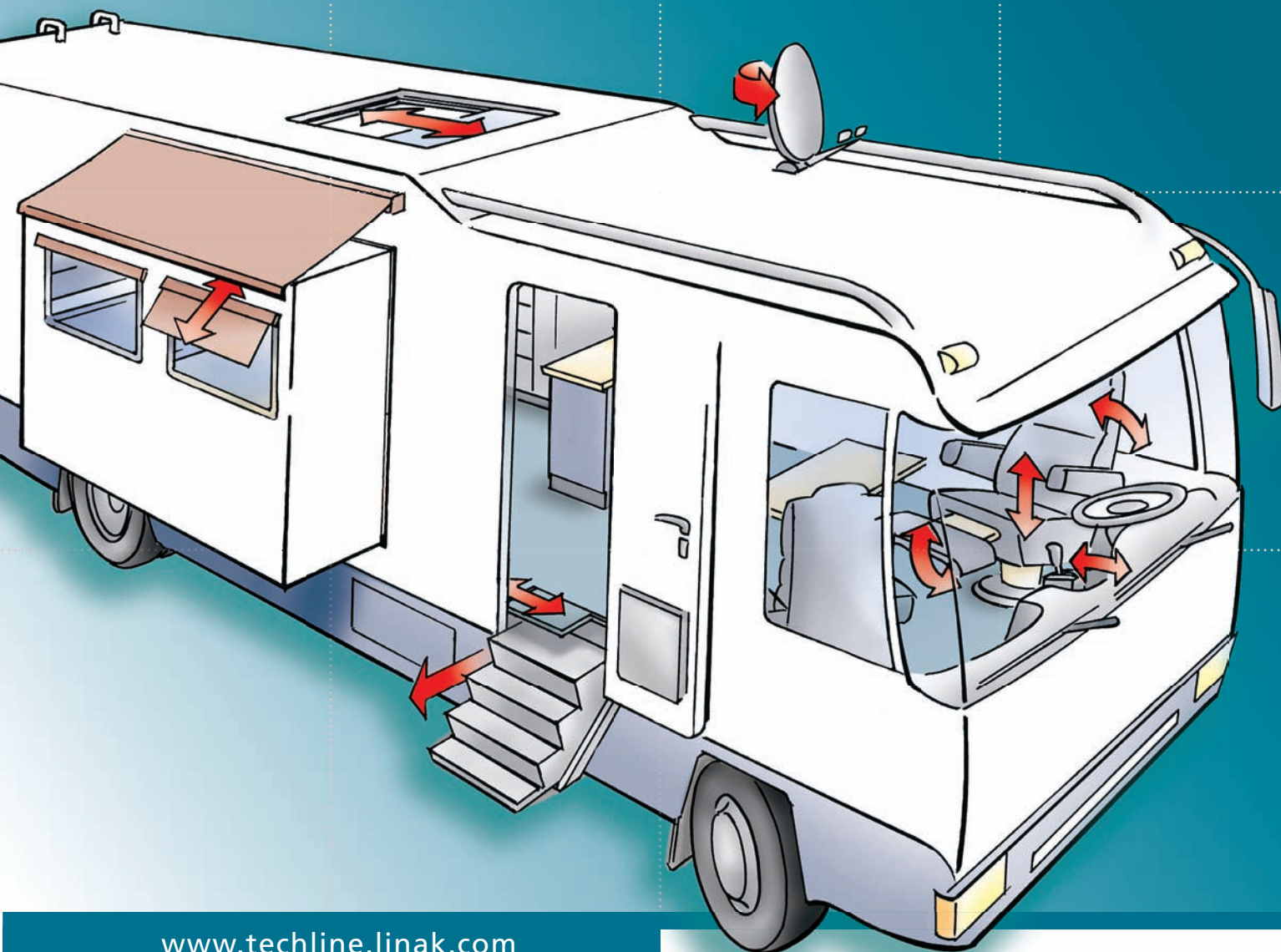

[www.techline.linak.com](http://www.techline.linak.com)

FOCUS ON MOTOR COACHES

**LINAK®**   
WE IMPROVE YOUR LIFE

## A WIDER RANGE OF SOLUTIONS

For applications in motor coaches it is often critical that the products work under extreme conditions. LINAK® actuators are very suitable to use in harsh conditions like water steam, dust, dirt and variable weather. Even in these circumstances the actuators do not need maintenance and continue to do their job day after day.

For applications inside the motor coach you will find that LINAK® actuators get the job done safely while remaining quiet.

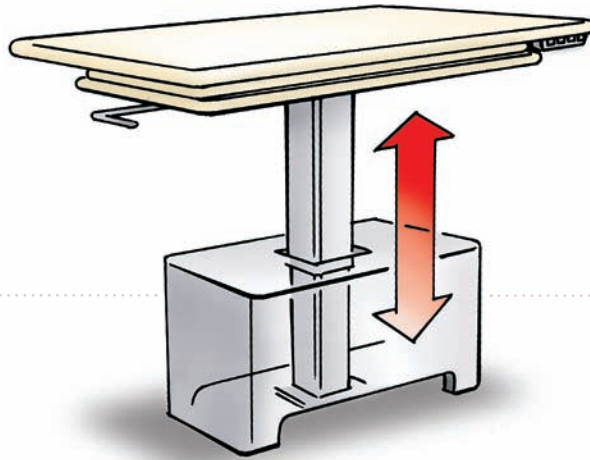

Tables can also be adjusted electrically. For example a DL2 system can be used to lower the dinner table to the height of a coffee table as well as offer support for a bed.

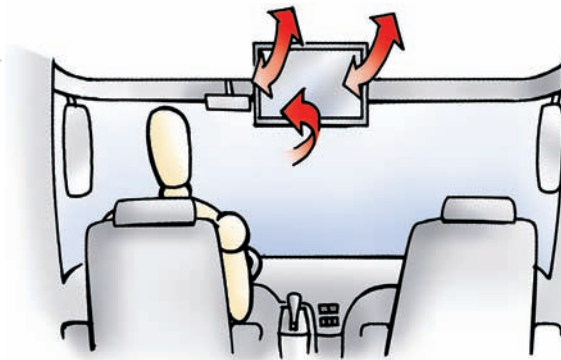

The hanging monitors in the cabin can be folded in and out by using an LA12 actuator.



The back and footrest of the seats can be adjusted smoothly for optimum comfort.

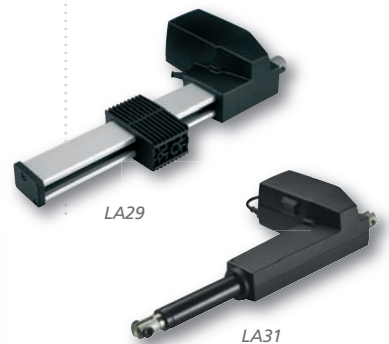



The angle of the satellite dish can automatically be adjusted for improved signal or lowered to driving position.



LA12



LA36



LA12

In order to increase the living area the wall of the motor home can be extended.

Actuators are used for creating the movement in the extension but also for locking the wall in open or closed position.

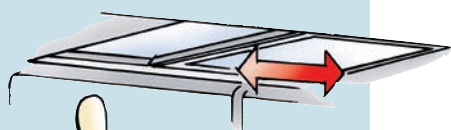
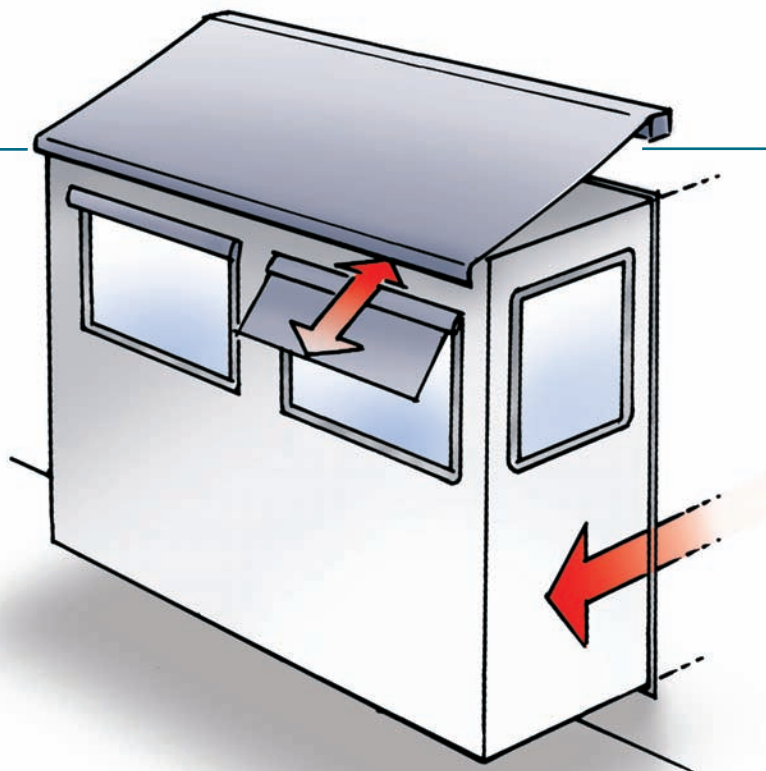

LA28



LA12

Opening and closing of inaccessible roof top hatches will be much easier when using actuators.



LA30

The lowering/lifting of the steps as well as the opening/closing of the cover is easily done at the touch of a button.

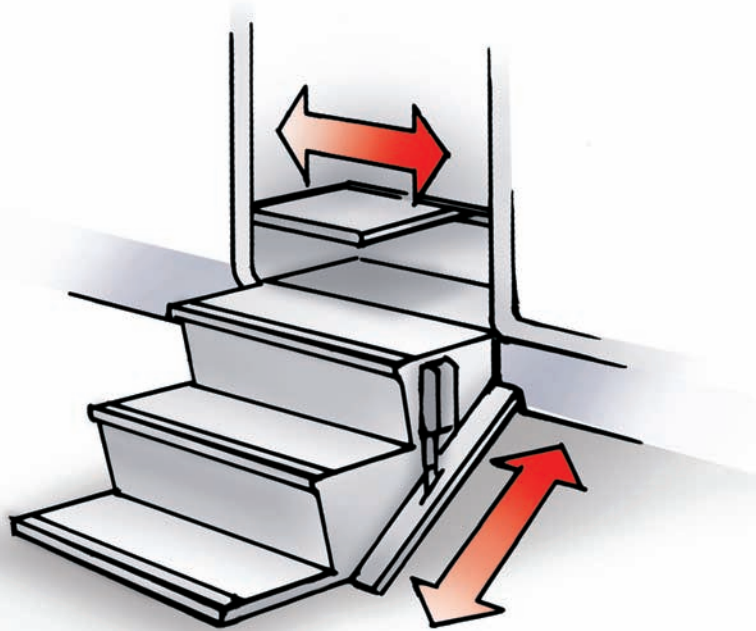



## LINAK ACTUATOR TECHNOLOGY PUTS MOTION TO

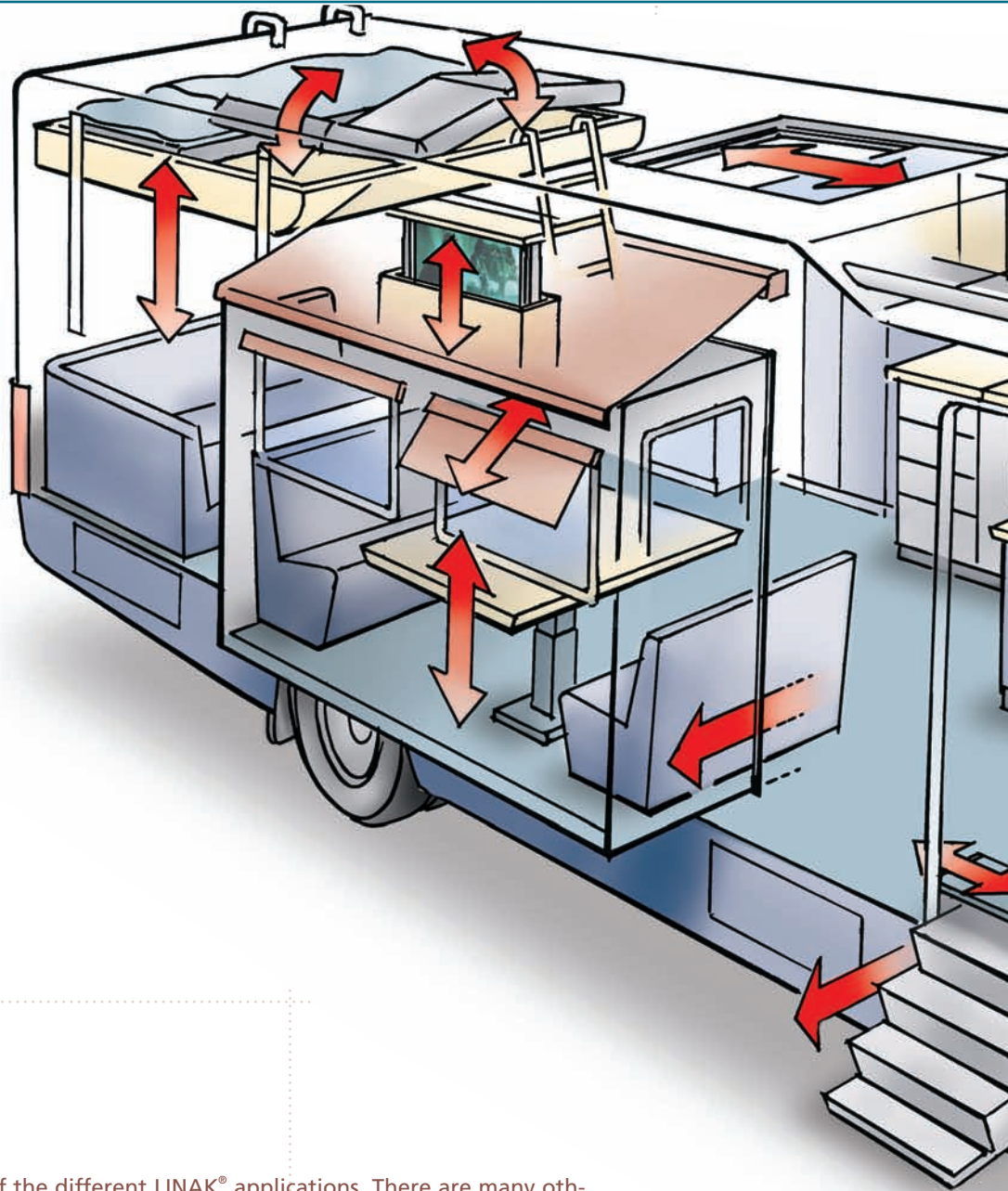

This illustration shows just some of the different LINAK® applications. There are many other possibilities for electrical adjustment.

Do you have an adjustment need or problem?

If so, please contact one of the LINAK dealers and we can give you customized advice.



## MOTOR COACHES

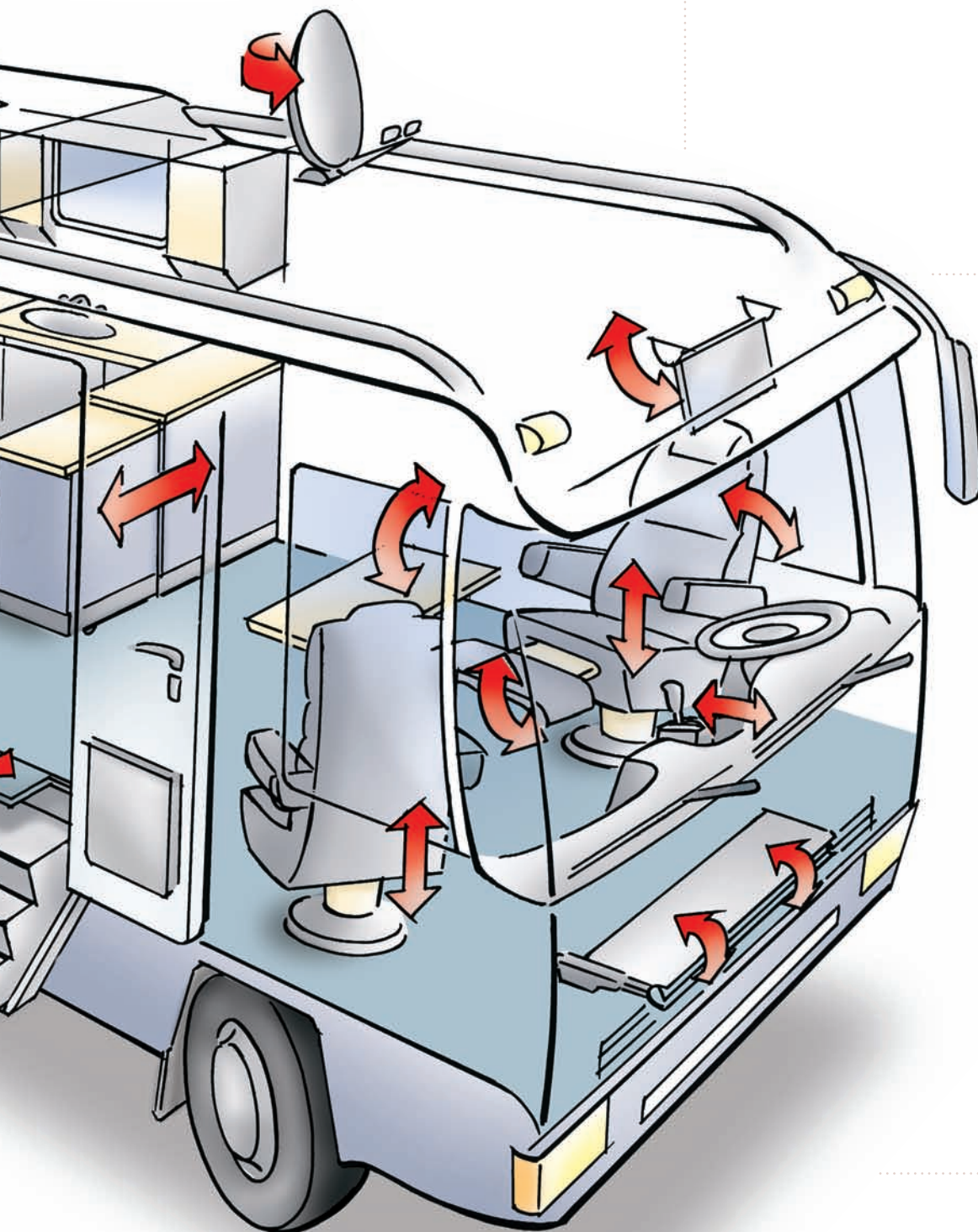

### Terms of use

The user is responsible for determining the suitability of LINAK® products for a specific application.

LINAK takes great care in providing accurate and up-to-date information on its products. However, due to continuous development in order to improve its products, LINAK products are subject to frequent modifications and changes without prior notice. Therefore, LINAK cannot guarantee the correct and actual status of said information on its products. While LINAK uses its best efforts to fulfill orders, LINAK cannot, for the same reasons as mentioned above, guarantee the availability of any particular product. Therefore, LINAK reserves the right to discontinue the sale of any product displayed on its website or listed in its catalogues or other written material drawn up by LINAK.

All sales are subject to the Standard Terms of Sale and Delivery for LINAK. For a copy hereof, please contact LINAK.





DL4

*LINAK® actuators make it possible to lower a TV-screen by the use of 2 columns of less than 10 x 5 cm.*

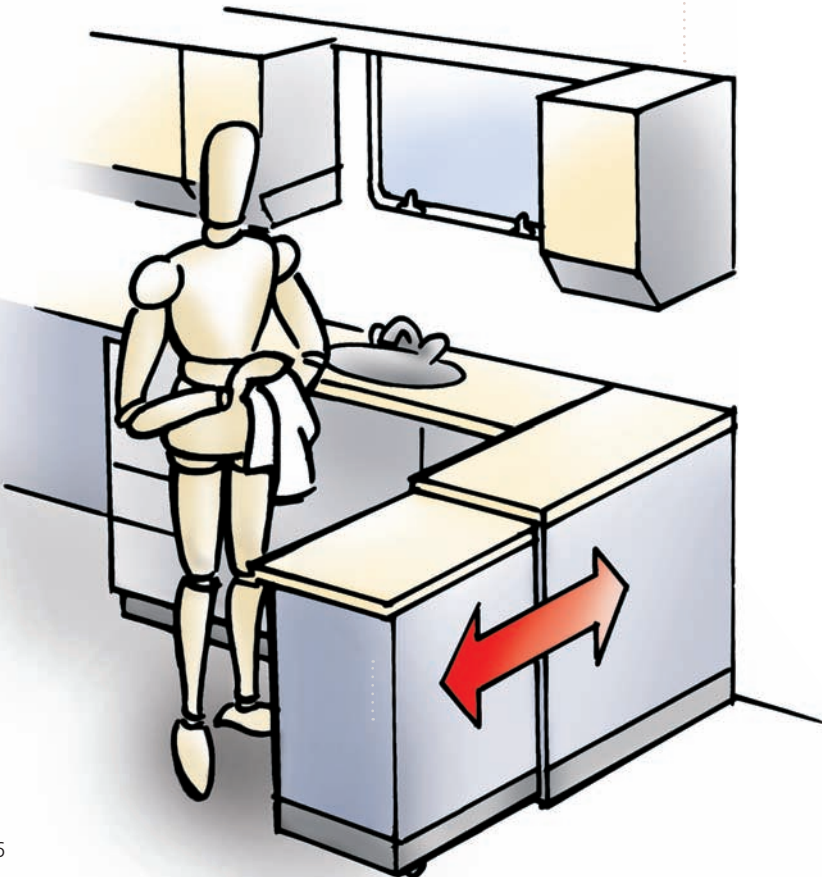
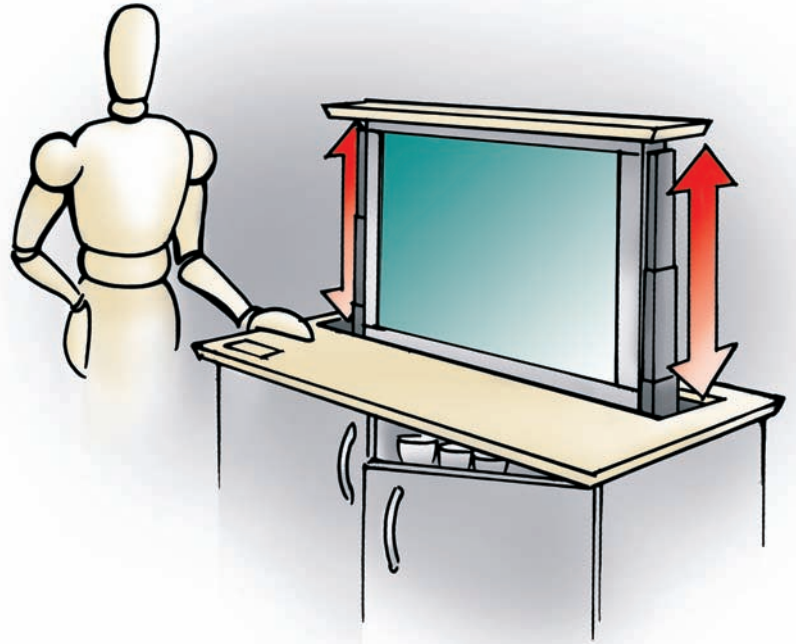

LA31

*The kitchen unit can be slid out in order to enlarge the working area. After use the element can be slid in again and thereby giving more free space.*



## POWERFUL MOTION IS WHAT WE DO

### CLOSE COLLABORATION

LINAK always likes to be involved in the early stage of the customer's product development to ensure that the actuators are used in an optimum way.

Heavy or light-duty, LINAK® actuators do the job even under extreme conditions.



LA31

*The LINAK® system provides a smooth adjustment of the headrest and footrest. Thus enabling the user to find the most comfortable position.*



LA32

*Up/down adjustment of the bed frame for optimal utilization of the space. At the maximum height you have a living room below the bed while at minimum height it can be used as a bed.*

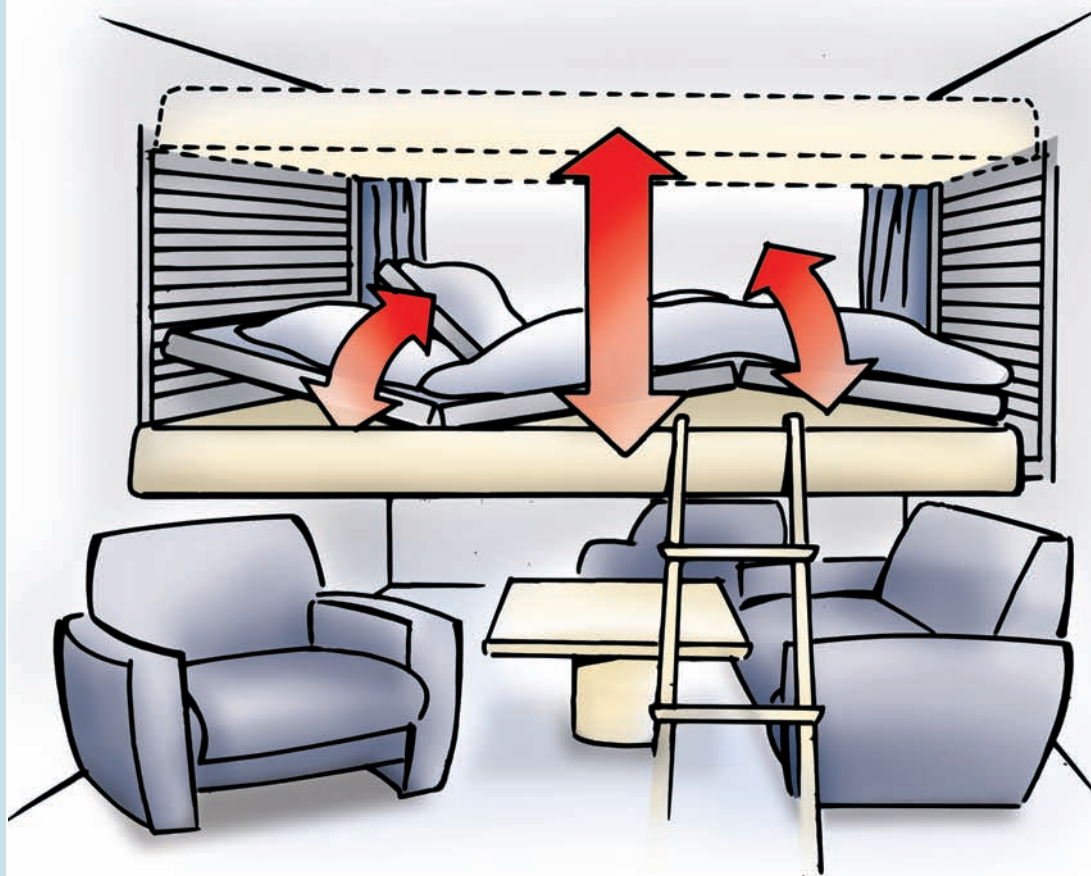





FOCUS ON MOTOR COACHES

WE PROVIDE PRODUCTS THAT IMPROVE  
PEOPLE'S QUALITY OF LIFE AND WORKING ENVIRONMENT



WE IMPROVE YOUR LIFE

LINAK U.S. Inc.  
North and South American Headquarters  
2200 Stanley Gault Parkway  
Louisville, KY 40223