

ELASTOMERIC COUPLINGS - RIGID COUPLINGS (BACKLASH FREE)

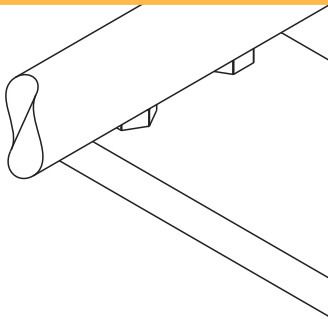
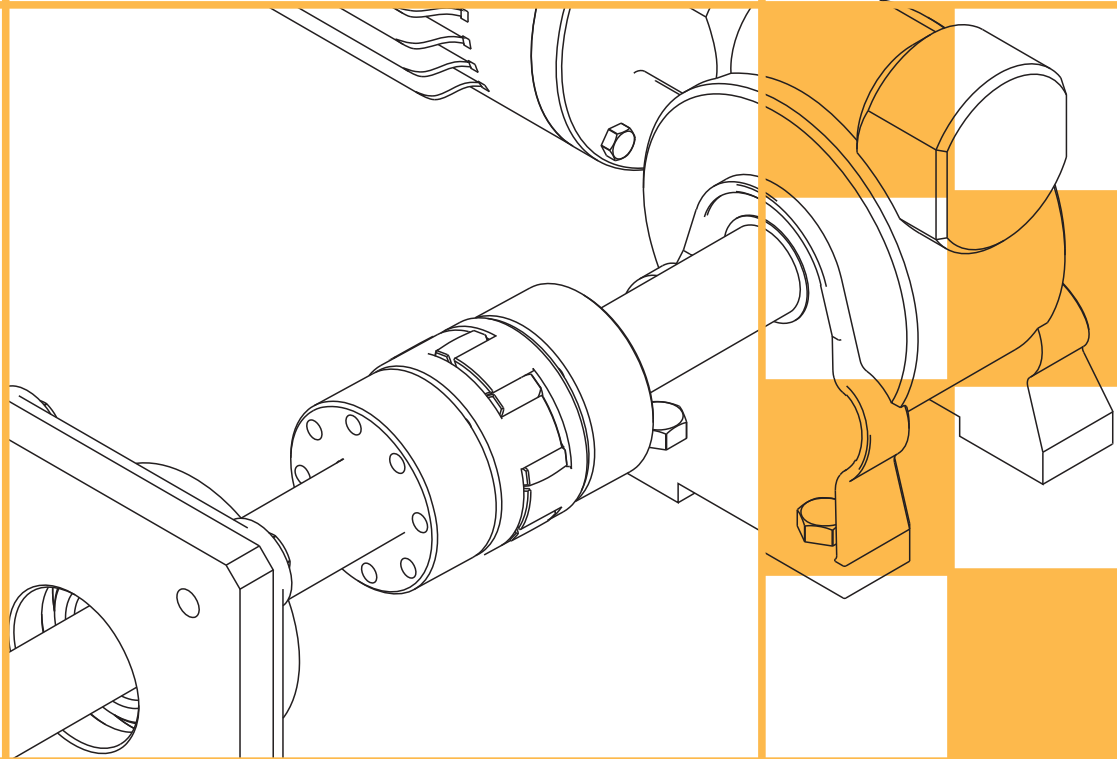
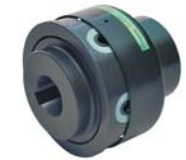

ComIntec[®]

ELASTOMERIC COUPLINGS - RIGID COUPLINGS (BACKLASH FREE): introduction

The aim of the flexible coupling is to transfer motion between two shafts on the same axis whilst accounting for possible misalignments. We have various styles of flexible couplings suitable for a wide range of applications. The quality of the materials used, the careful design and the precision in manufacturing ensure long lasting high performance, safety and reliability for even the most complex applications.

Strengths of our Models ...

- Available in fully turned steel.
- Good reliability.
- Different customization possibilities.
- Wide selection.
- Highly accurate manufacturing.
- Optimum protection against environmental conditions.
- Competitive pricing without sacrificing quality.
- "Made in Italy" with certified quality.



Our main product ranges ...

- "RIGID COUPLINGS (BACKLASH FREE)": for connections when high precision and high transmission torques are required.
- "ELASTOMERIC COUPLINGS": for connection between misaligned shafts with the need to absorb vibrations.

DISC COUPLING "GTR"



Torsionally rigid disc coupling with angular backlash free transfer of motion. Transmission and maximum flexibility in operation.
Max. torque 30000 Nm – max. bore \varnothing 140 mm.

RIGID COUPLING "GRI"



Rigid coupling, in steel, suitable for shaft connections with good alignment.
Max. torque 450 Nm – max. bore \varnothing 50 mm.

BELLOW COUPLING "GSF"



Bellow coupling in aluminium with high torsional rigidity. Backlash free, low inertia and high reliability.
Max. torque 300 Nm – max. bore \varnothing 45 mm.

BACKLASH FREE JAW COUPLING "GAS/SG"



Backlash free jaw coupling. Available with a range of hub connections and elastomeric elements.
Max. torque 2080 Nm – max. bore \varnothing 80 mm.

JAW COUPLING "GAS"



Elastomeric jaw coupling, good vibration dampening properties. Available with a range of elastomeric elements depending on the application requirements.
Max. torque 9000 Nm – max. bore \varnothing 110 mm.

COMPACT ELASTIC COUPLING "GEC"



Elastomeric coupling, compact and protected from environmental conditions. Fast maintenance possible without the need to move the shafts.
Max. torque 35000 Nm – max. bore \varnothing 180 mm.

GEAR COUPLING "GD"



Gear coupling without wear due to the polyamide sleeve, suitable for high axial misalignments.
Max. torque 5000 Nm – max. bore \varnothing 125 mm.

HIGHLY FLEXIBLE COUPLING "GF"



Highly flexible coupling with compact dimensions, suited for applications where high shaft misalignments are present. Maintenance without the need to move the shafts.
Max. torque 5100 Nm – max. bore \varnothing 85 mm.

CHAIN COUPLING "GC"



Simple, economic and easy to assemble **chain coupling**. Suitable for dry and dusty environments.
Max. torque 8000 Nm – max. bore \varnothing 110 mm.

SELECTION GUIDE



CHARACTERISTICS

	GTR page 6	GRI page 12	GSF page 14	GAS/SG page 16	GAS page 18	GEC page 26	GD page 28	GF page 30	GFI page 31	GC page 32
Manufactured in turned steel	■	■		■	■	■	■	■	■	■
Manufactured in aluminium			■						■	
Elastomeric				■	■	■		■	■	
Medium torsional rigidity						■	■			
High torsional rigidity	■		■	■						
Completely rigid		■								
Jaw connection				■	■		■		■	
Compact dimensions		■	■	■	■	■	■	■	■	
Modular system			■	■	■		■			
Reduced inertia			■						■	
Statically balanced	■	■	■	■	■	■	■	■	■	■
Electric insulation between parts				■						
Available with customized spacers	■			■	■					
Assembly possible with ComInTec TORQUE LIMITERS	■		■	■	■	■		■		■

ADVANTAGES AND BENEFITS

High transmittable torque	■	■				■				
Maintenance free	■	■	■				■			■
Economic solution		■	■		■		■		■	■
Suitable for frequent reversal of drive	■		■	■		■				
Suitable for high temperatures (>150°C)		■	■			■				■
Maintenance possible without the need to move the shafts	■					■		■		■
Silent transmission		■		■	■	■		■	■	
Vibration dampening				■	■			■	■	
Suitable for high speeds	■			■			■			
Simple and fast assembly				■	■		■		■	■
Conformity to ATEX (on request)				■	■					
High compensation of misalignments					■			■		
Average compensation of misalignments						■	■		■	■
Low compensation of misalignments	■		■	■						

APPLICATIONS

CNC and precision machines	■		■	■						
Servomotors, linear guides, transducers			■	■						
Food and chemical sectors	■			■	■	■				
Textile and printing machines	■					■				
Pumps, compressors, turbines				■	■	■	■			
Conveyor belts					■			■		■
Solar trackers				■						
Tachos, encoders			■						■	
Packing machines				■	■					
Extruders, mixers and agitators						■				
Farm machines, earth-moving equipment							■	■		■
Printing, laminating						■				
Test benches	■					■				
Motion control		■	■							

APPLICATION EXAMPLES

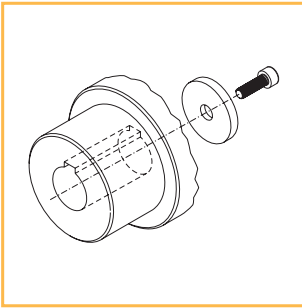

Locking with screw and washer, useful for fixing the coupling on the shafts where threaded hole is available.

Locking with grub screw on the keyway. Standard solution on the hubs shown in the catalogue. Suitable for horizontal assembling.

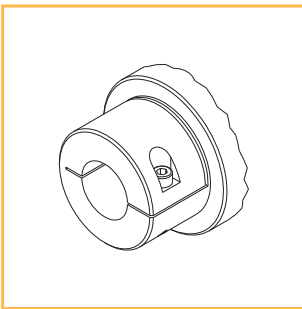
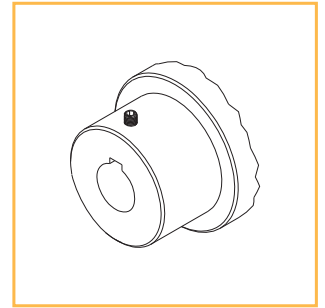

Single split clamp hub with or without keyway. Reduction of angular backlash without change to the standard dimensions.

Clamp connection with locking assembly built into the hub (CCE/version), advised on high speeds and without change to standard dimensions.

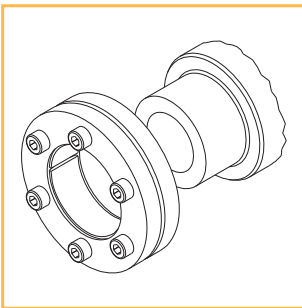
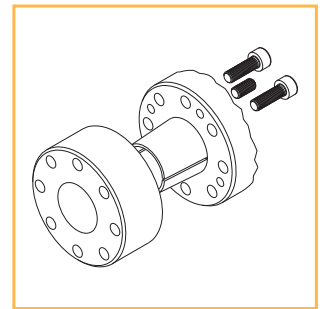

Clamp connection with external locking assembly (shrink disk), suitable to transmit high torque while maintaining compact axial dimensions.

Clamp connection with internal locking assembly. Reduction of angular backlash and reduced axial dimensions without compromising the transmittable torque of the coupling.

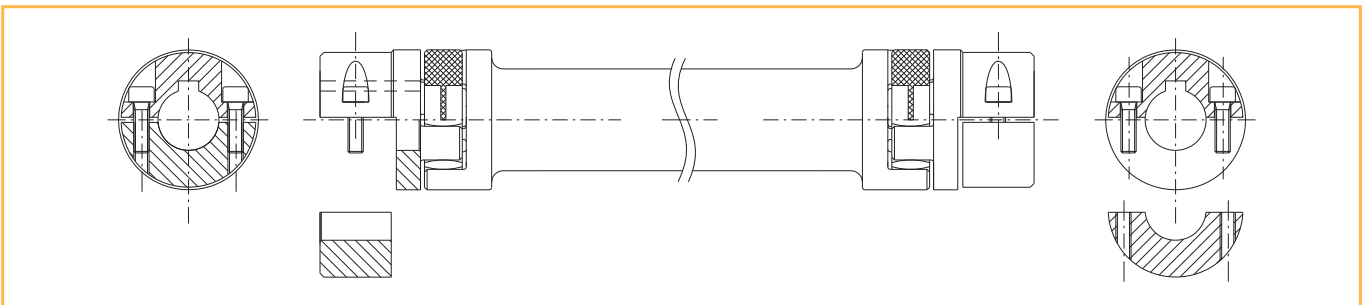
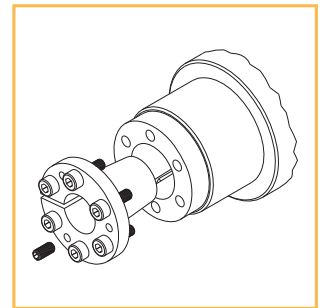

Clamp connection via a two section hub bored H7 allowing easy extraction. Extreme ease in assembling, disassembling and maintenance without disconnecting the shafts but simply extracting the coupling radially. Fully modular, the coupling can be supplied with spacers made to length with surface treatments suitable for even the most aggressive environments.

SELECTION OF THE SERVICE FACTOR AND TORQUE CALCULATION

For correct dimensioning of the chosen coupling, it is necessary to determine the correct torque to be transmitted, taking into consideration the type of application and determining the service factor "f". In the table below, this value is indicated referring to some common applications. The formula to calculate the torque value is the following:

$$C_{nom} = \frac{9550 \cdot f \cdot P}{n}$$

Dove:

- C_{nom} = coupling's nominal torque [Nm]
- f = service factor
- n = speed [Rpm]
- P = power applied [kW]

If the calculated torque to be transmitted is included between two couplings' sizes, always choose the one that offers the highest torque.

Sector	Type of machine	Service factor (f)	
		Combustion engines water turbines	Electric engines Gas and steam turbines
Machines for food industries	Bottlers	1,5	2,0
	Centrifuges, mixers, crushers	2,0	2,6
	Sugar cane mills	3,0	3,5
Machines for chemical industries	Agitators, mixers, heavy centrifuges, cooling drums	2,0	2,6
Machines for building industries	Elevators, earth-moving machines	2,0	2,6
Machines for extraction industries	Pumps for pipelines	2,0	2,6
	Drilling installations	3,0	3,5
Machines for rubber processing industries	Calendars	2,0	2,6
	Extruders, mixers, mills and rolls	3,0	3,5
Machines for metalworking industries	Gears	1,0	1,5
	Machine tools, shears, bending machines	2,0	2,6
	Presses, punches, straighteners	3,0	3,5
Machines for textile industries	Printing apparatus, lap machines, pickers, frames	2,0	2,6
Fans	Large-blade centrifuges	1,5	2,0
Conveyors	Chain, screw, plate conveyors elevators	2,0	2,6
	Inclined elevators, extraction systems, belt conveyors	3,0	3,5
Machines for paper industries	Calendars	2,0	2,6
	Paper pressers, paper rolls	3,0	3,5
Machines for mining industries	Suction pumps, control winches	2,0	2,6
	Blade wheels, bucket excavators	3,0	3,5
Compressors	Axial, centrifugal, radial	1,0	1,5
	Turbocompressors	2,0	2,6
	Alternative	3,0	3,5
Machines for plastic processing industries	Calendars, crushers, mixers	2,0	2,6
Machines for woodworking industries	Generic woodworking	1,0	1,5
	Planning machines	2,0	2,6
	Bark-peelers, saws	3,0	3,5
Machines for laminating industries	Light roller ways	2,0	2,6
	Cold rolling mills, pipe welders, ingot conveyors cutting-off machines	3,0	3,5
Pumps	Centrifuges	1,0	1,5
	Centrifuges for viscous liquids	2,0	2,6
	Alternative, pressure	3,0	3,5
Cranes	Hoisting, translation	1,0	1,5
	Rotating	2,0	2,6

GTR – torsionally rigid coupling: introduction



- Made in steel fully turned with standard treatment of phosphating.
- Disc pack in stainless steel.
- High torsional rigidity.
- Maintenance and wear free.
- Version with double disc pack and spacer made to length.
- High torque possible.

ON REQUEST

- Use in applications with high operation temperatures (> 150 °C) possible.
- Specific treatments or version in full stainless steel possible.
- Customized versions for specific needs.
- Connection to ComInTec TORQUE LIMITERS range possible.

Designed to suit applications where high reliability, precision and an optimum weight/power ratio is required; ideally suited for applications with high speeds and power, also offering low overhung loads when using spacer version.

This coupling is composed of three main items: the two fully turned hubs, made in steel UNI EN10083/98 and the disc pack, in stainless steel AISI 304 C with connection screws in steel class 10.9. In the “double” version, GTR/D, there is also a spacer made to length, also built in steel UNI EN10083/98, fixed between the hubs and the two disc packs.

All the components of GTR couplings, except the spacer, are made and balanced into class DIN ISO 1940-1:2003 Q 6.3, before the machining of the keyway.

In accordance to the specific need of the application, it is possible to make static or dynamic balancing on each separate component or on the coupling, fully assembled to customer requirements.

DESCRIPTION OF DISCS

The fundamental elements of this torsionally rigid coupling are the disc packs, built from a series of stainless steel discs type AISI 304-C, connected by steel bushes. This disc pack is connected in an alternate way to the hub flange or the eventual spacer, by using screws in steel class 10.9 and the relevant self-locking nuts.

With reference to the configuration, the disc packs can be:

- Unique discs with continuous ring (coupling sizes 1-7)
- Disc sections (coupling sizes 8-12)

Continuous ring disc pack
(sizes 1-7)

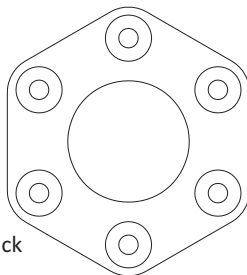

Sectional disc pack
(sizes 8-12)

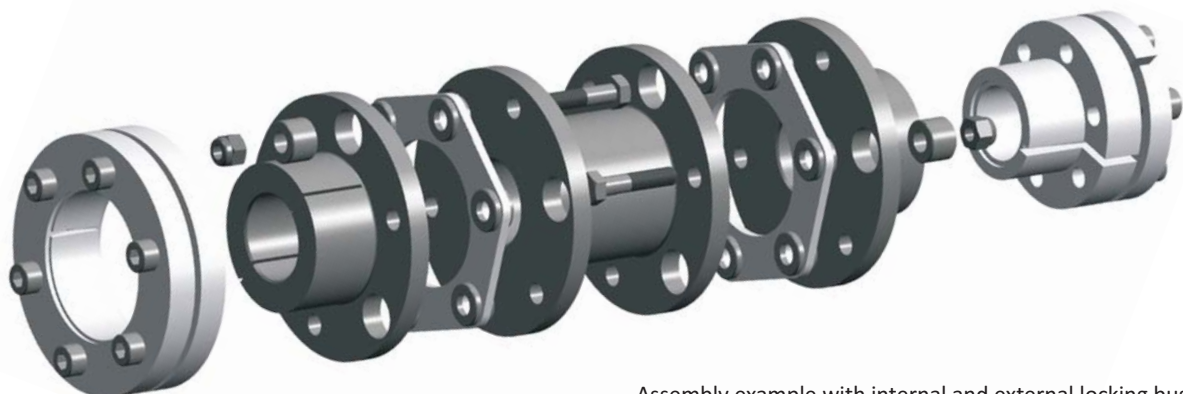
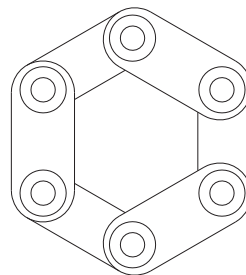

Assembly example with internal and external locking bushes

GTR – torsionally rigid coupling: introduction

MANUFACTURING

Version with spacer supplied, made to length, according to the application needs.

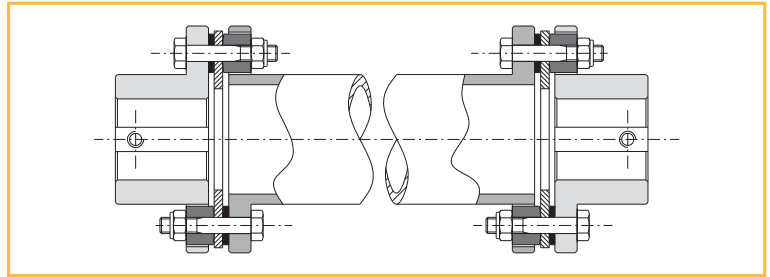

Manufacturing with internal hubs in order to reduce the axial dimensions.

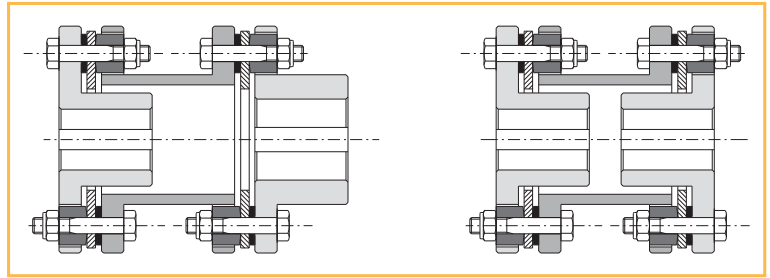

Manufacturing in addition to the /SG torque limiters range, with simple and/or double disc pack.

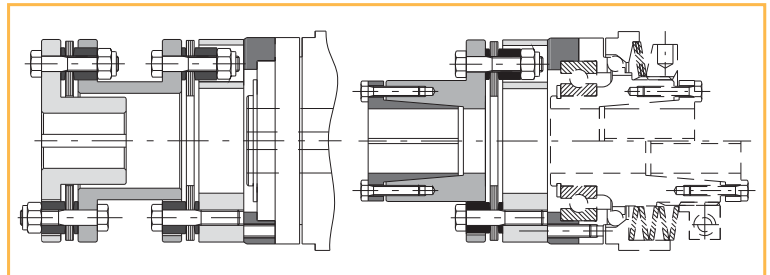

Solution with adaptors both in simple and double version, for easy substitution of disc packs without moving the hubs (in accordance with directive API610).

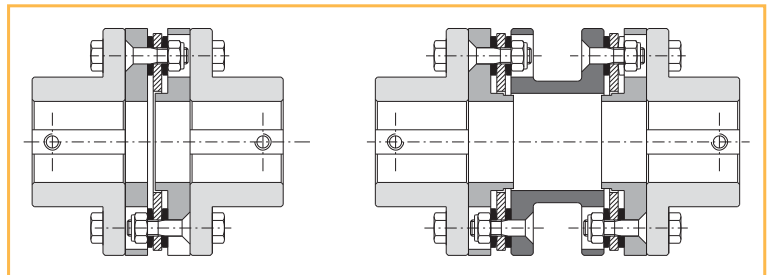

Solution for vertical mounting, where the spacer has to be supported to avoid the weight pre-loading the disc pack.

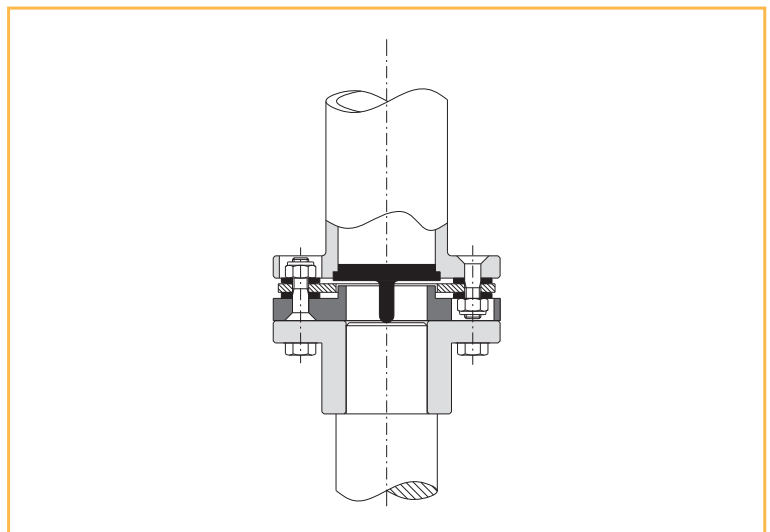

GTR – torsionally rigid coupling: technical data

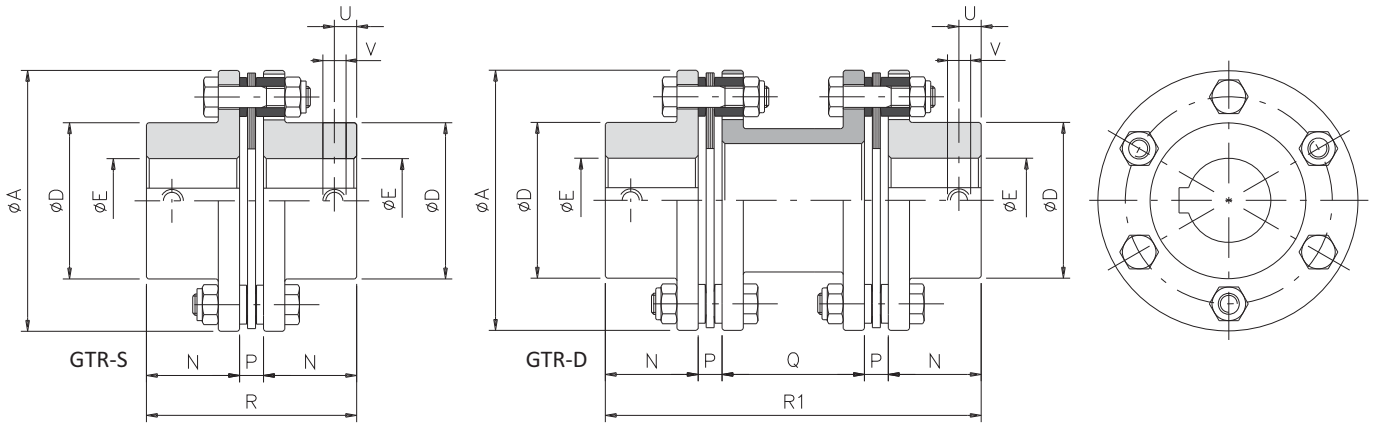

DIMENSIONS

Size	GTR-S code	GTR-D code	A	D	E H7 max	E4 H7 max	N	P	Q Std *	R	R1	U	V
0	200965000000	200819000000	78	45	32	25	29	7,5	50	65,5	123	10	M5
1	200825000000	200829000000	80	45	32	25	36	8	50	80	138	10	M5
2	200835000000	200839000000	92	53	38	30	42	8	50	92	150	10	M5
3	200845000000	200849000000	112	64	45	35	46	10	59	102	171	15	M8
4	200855000000	200859000000	136	76	52	45	56	12	75	124	211	15	M8
5	200865000000	200869000000	162	92	65	55	66	13	95	145	253	20	M8
6	200875000000	200879000000	182	112	80	70	80	14	102	174	290	20	M8
7	200885000000	200889000000	206	130	90	80	92	15	101	199	315	20	M10
8	200895000000	200899000000	226	135	95	80	100	22	136	222	380	20	M10
9	200925000000	200929000000	252	155	110	-	110	25	130	245	400	25	M12
10	200935000000	200939000000	296	170	120	-	120	28	144	268	440	25	M12
11	200945000000	200949000000	318	195	138	-	140	32	136	312	480	30	M16
12	200955000000	200959000000	320	200	140	-	150	32	156	332	520	30	M16

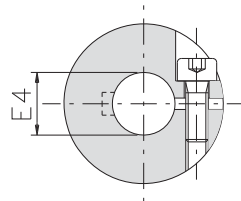

Clamp locking (on request)

TORQUE PERMISSIBLE WITH CLAMP LOCKING (GTR-S & GTR-D)

Size	Torque transmitted [Nm] relevant to the ϕ finished bore [mm]																											
	10	11	12	14	15	16	18	19	20	22	24	25	28	30	32	35	38	40	42	45	48	50	55	60	65	70	75	80
0	18	19	19	20	20	21	22	22	22	23	24	25																
1	18	19	19	20	20	21	22	22	22	23	24	25																
2			41	42	43	44	45	45	46	47	49	49	51	53														
3							90	91	92	95	97	98	102	104	107	110												
4									95	97	99	101	104	106	108	111	115	117	119	123								
5												260	267	272	276	284	291	296	301	308	316	321	333					
6																	494	501	508	519	530	537	555	573	591	609		
7																			539	549	560	567	585	603	621	639	657	676
8																				1097	1117	1131	1166	1201	1236	1271	1306	1342

GTR-S TECHNICAL CHARACTERISTICS

Size	Torque [Nm]		Weight [Kg]	Inertia [Kgm ²]	Max speed [Rpm]	Axial load [Kg]	Tightening torque disc pack screws [Nm]	Misalignment			Rigidity [Nm/rad·10 ³]
	Nom	Max						angular α [°]	axial X [mm]	radial K [mm]	
0	60	120	1,6	0,00058	27500	10	12	1°	1,40	-	80
1	100	200	1,3	0,00067	25000	14	12	0° 45'	0,80	-	117
2	150	300	2,4	0,00193	22000	19	13	0° 45'	0,95	-	156
3	300	600	3,9	0,00386	20000	26	22	0° 45'	1,25	-	415
4	700	1400	6,3	0,00869	16000	34	39	0° 45'	1,45	-	970
5	1100	2200	10,4	0,01009	14000	53	85	0° 45'	1,65	-	1846
6	1700	3400	15,6	0,03648	12000	70	95	0° 45'	2,00	-	2242
7	2600	5200	24,8	0,07735	10000	79	127	0° 45'	2,25	-	3511
8	4000	8000	33,0	0,13403	8000	104	260	0° 45'	2,45	-	8991
9	7000	14000	42,0	0,25445	7500	115	480	0° 45'	2,55	-	11941
10	9000	18000	67,0	0,45019	6000	138	760	0° 45'	2,65	-	14154
11	12000	24000	94,0	0,71654	5500	279	780	0° 45'	2,95	-	15521
12	15000	30000	114,0	1,06933	5500	358	800	0° 45'	3,05	-	16409

GTR-D TECHNICAL CHARACTERISTICS

Size	Torque [Nm]		Weight [Kg]	Inertia [Kgm ²]	Max speed [Rpm]	Axial load [Kg]	Tightening torque disc pack screws [Nm]	Misalignments			Rigidity R _T [Nm/rad·10 ³]
	Nom	Max						angular α [°]	axial X [mm]	radial K [mm]	
0	60	120	1,7	0,00083	25000	12	12	1° 30'	1,40	0,70	42
1	100	200	1,8	0,00092	25000	14	13	1° 30'	1,60	0,79	51
2	150	300	3,5	0,00286	22000	19	13	1° 30'	1,90	0,79	71
3	300	600	5,8	0,00740	20000	26	22	1° 30'	2,50	0,95	184
4	700	1400	9,4	0,01660	16000	34	39	1° 30'	2,90	1,18	422
5	1100	2200	15,2	0,02850	14000	53	85	1° 30'	3,30	1,45	803
6	1700	3400	23	0,06358	12000	70	95	1° 30'	4,00	1,56	1019
7	2600	5200	34	0,12816	10000	79	127	1° 30'	4,50	1,57	1596
8	4000	8000	47	0,22927	8000	104	260	1° 30'	4,90	2,16	3996
9	7000	14000	61	0,44598	7500	115	480	1° 30'	5,10	2,16	5192
10	9000	18000	96	0,79995	6000	138	760	1° 30'	5,30	2,40	6024
11	12000	24000	132	1,22823	5500	279	780	1° 30'	5,90	2,40	6748
12	15000	30000	166	1,85186	5500	358	800	1° 30'	6,10	2,64	7293

NOTES

- ⊗ **Code:** the 7th, 8th, 9th digits of the code indicate the finished bore diameter of a half-hub in mm (000 = Pilot Bore).
- ⊗ **Code:** the 10th, 11th, 12th digits of the code indicate the finished bore diameter of the second half-hub in mm (000 = Pilot Bore).
- ⊗ **Q std (*):** different dimensions available on request.
- ⊗ **Technical characteristics:** the weights refer to the coupling with pilot bore; inertias refer to the coupling with maximum bore.

GTR – torsionally rigid coupling: additional information

DIMENSIONING

For pre-selection of the coupling's size you can use the generic formula indicated on page 5.

The GTR coupling will accommodate momentary peak torque "C.C." of 2,5 times than nominal torque.

If the C.C. is higher than 2,5 times than the nominal torque, it is necessary to choose the coupling using the following formula:

$$C'_{nom} = \frac{C.C.}{2,5}$$

⇒

$$C_{nom} \geq C'_{nom}$$

⇒

Where:

C'_{nom} = theoretic nominal torque of the coupling [Nm]
 C_{nom} = effective nominal torque of the coupling [Nm]
 C.C. = peak torque [Nm]

The nominal torque indicated on the catalogue for GTR coupling refers to the static torque 2 times lower than the nominal torque, with service factor f=1.5. On the contrary, if the static torque of the motor is two times higher than the nominal one, it is possible using the following formula:

$$C'_{nom} = \frac{C_{spunto}}{1,5}$$

⇒

$$C_{nom} \geq C'_{nom}$$

⇒

Where:

C'_{nom} = theoretic nominal torque of the coupling [Nm]
 C_{nom} = effective nominal torque of the coupling [Nm]
 C_{spunto} = static torque [Nm]

Having calculated the theoretical nominal torque (C'_{nom}), so that the coupling can be sized correctly it is necessary, to compare the effective technical characteristics of GTR (pages 8-9) and to choose the size able to transmit an effective nominal torque (C_{nom}) higher or equal to the one found by the described formulae above.

Having established the size of the coupling to be used, it is possible to make other checks considering further parameters:

$$C_{nom} > \frac{9550 \cdot P}{n} \cdot f \cdot f_T \cdot f_D$$

⇒

$$C_{nom} > \frac{9550 \cdot P}{n} \cdot f_k \cdot f_T \cdot f_D$$

⇒

Where:

C_{nom} = nominal torque of the coupling [Nm]
 f = service factor (pag.5)
 f_T = thermic factor (grafico 1)
 f_D = direction factor
 f_k = load factor
 n = speed [Rpm]
 P = applied power [kW]

It is important to consider that misalignments, axial, angular and parallel, must be considered paired together, as inversely proportional (one reduces when the other increases). If all types of misalignments occur, it is necessary that the sum in percentage with respect to the maximum value doesn't exceed 100%, according to "graphic 2".

Direction factor (f_D)	
1	one-sense rotation
1,2	alternate rotation

Load factor (f_k)	
1,5	continuous load
2	discontinuous load
1,5÷2	machine tools
2,5 ÷ 4	shock load

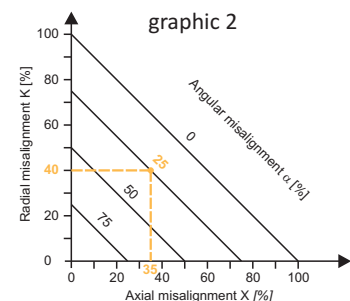
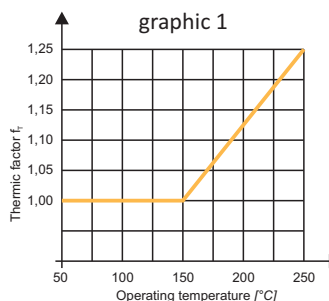

Moreover it is also possible to determine positioning error in accordance to the formula:

$$\beta = \frac{180 \cdot C_{mot}}{\pi \cdot R_T}$$

⇒

Where:

C_{mot} = maximum torque motor side [Nm]
 R_T = torsional rigidity of the coupling [Nm/rad]
 β = rotation angle [°]

- 1) Achieve radial and axial alignment as precisely as possible to permit the maximum absorption of possible misalignments and life of the coupling (picture 1 and 2).
- 2) Make sure that the shafts are assembled so that its extremity is square with the surface of the half-coupling (the length of the spacer including two disc packs should be equal to the distance between the two shafts) (picture 3).
- 3) Tightening the screws with a torque wrench in a cross sequence, continuously until you obtain the tightening torque indicated in the catalogue. It is recommended to rotate only the nut/bolt not in contact with the disk pack to prevent twisting of the laminations.
- 4) Finally it is necessary to check and ensure the disc packs are perfectly perpendicular to the shaft axis. It may be necessary to release and tighten some screws again.

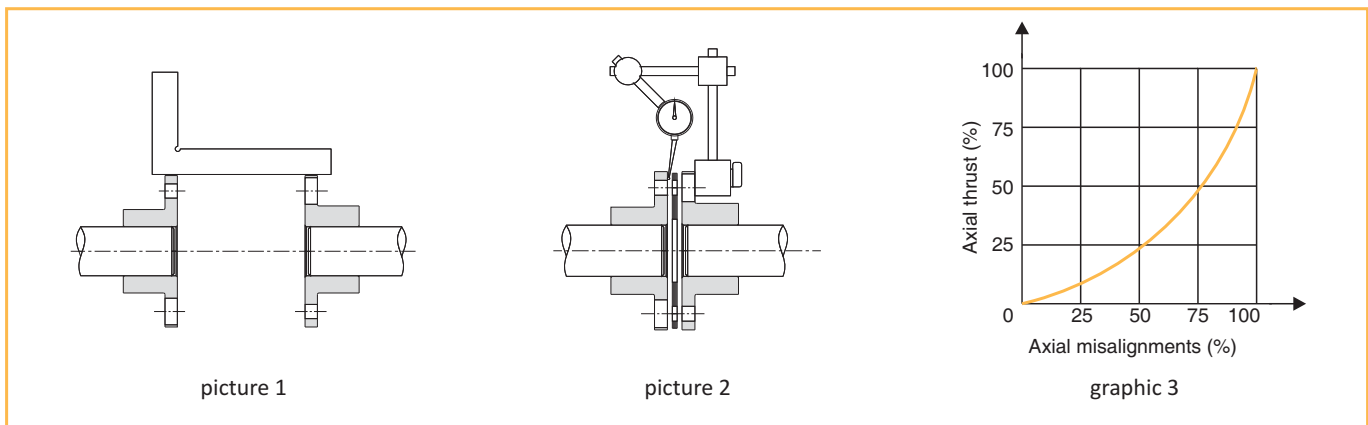

The rated outputs on the catalogue refer to normal use without shocks and with shafts well-aligned with the environmental temperature $-20\text{ }^{\circ}\text{C} + 250\text{ }^{\circ}\text{C}$ (pictures 1 and 2).

With the coupling GTR-D (double flexing version) with spacer it is possible to achieve double the angular misalignment (picture 5) compared to the single flexing version. Otherwise it's possible to accept radial misalignment (pictures 4).

The value of axial thrust (+ 20%) is relevant to the axial movement according to "graphic 3".

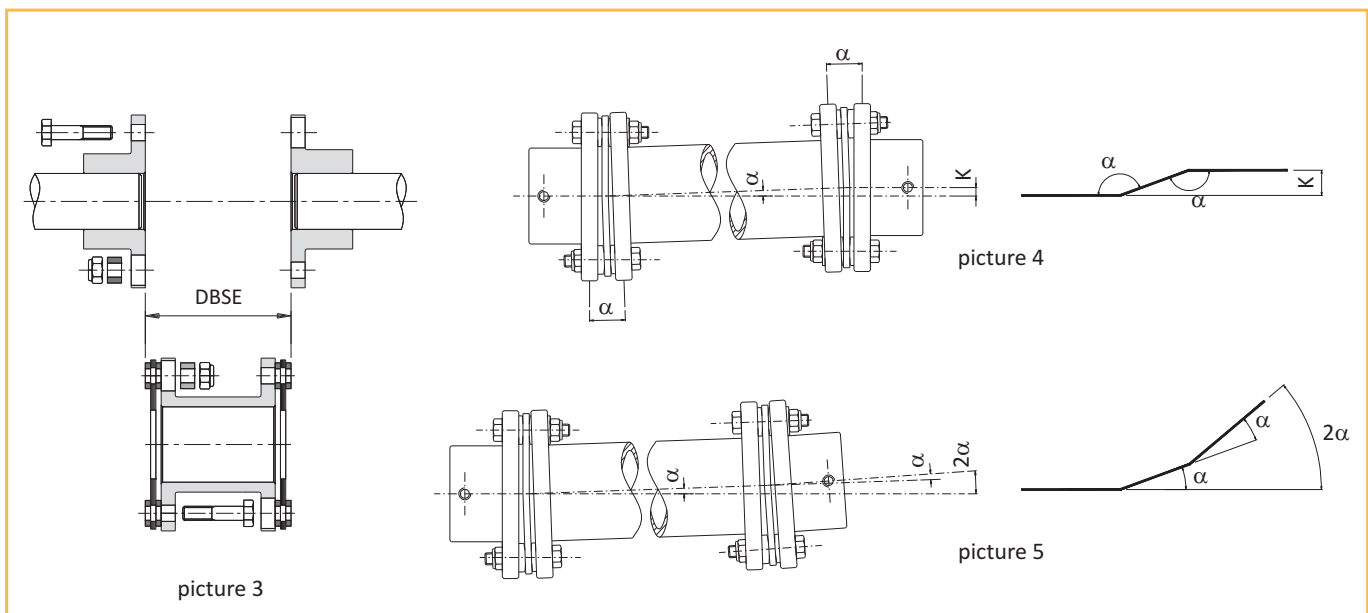

In the coupling with spacer, the central part of the couplings (spacing bar) can be considered as a weight suspended between two springs (lamellar pack), and it will have a natural frequency which, if excited, can produce some oscillations of the spacer causing damage to packs. It is recommended to increase the distance between the flanges of the hubs compared to the nominal dimensions "DBSE" (see picture 3) by 1,5 – 2 mm to decrease the natural axial frequency. In this way the lamellar packs are kept under tension and the possibility of spacer oscillation reduces.

GRI - rigid coupling: introduction



- Made in steel fully turned with phosphating treatment.
- Extremely rigid connection.
- High torque possible.
- Wear and maintenance free.
- Compact dimensions.
- Finished bore with ISO H8 tolerance and low roughness.

ON REQUEST

- Finished bore with keyway.
- Different customized bores.
- Two section design.
- Anti-corrosive surface treatments for specific needs possible.

GRI rigid couplings have been designed and manufactured to connect two shafts of the same diameter but without allowing any relevant misalignment.

The coupling is manufactured in one element for the single split version. A two piece unit is available on request allowing simple and fast mounting and dismounting.

DIMENSIONING

The nominal torque of the coupling must be higher than the maximum torque of the motor's side, according to the generic formula on page 5. The indicated torque values have been calculated based on a friction coefficient for shaft-coupling of $0.15 \mu\text{m}$.

FITTING

It is advised to machine the connection's shafts with:

- Surface finish with $Ra=1.6 \mu\text{m}$.
- Nominal tolerance h6.
- Be sure that the shafts are perfectly aligned.

Tighten the locking screws in steel class 8.8 with a torque wrench, in accordance to the tightening torque indicated in the catalogue.

APPLICATION EXAMPLE

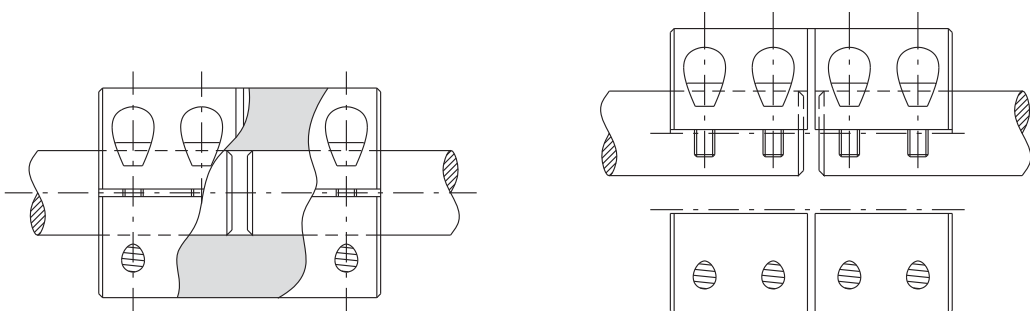

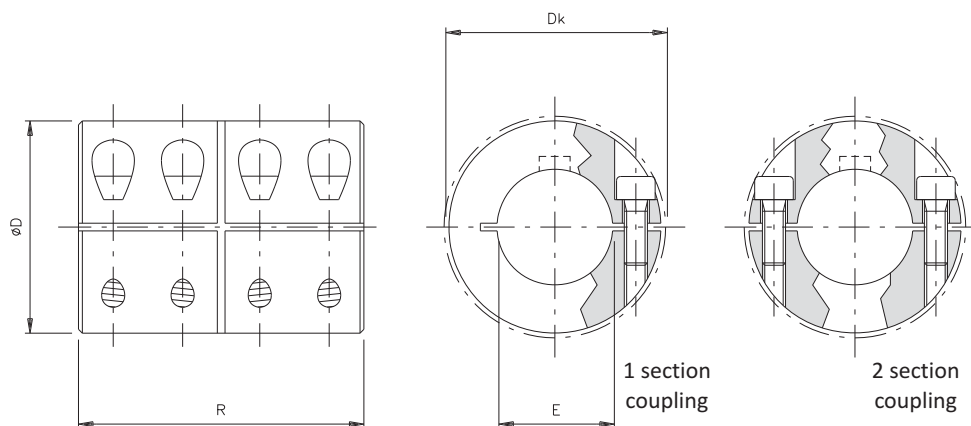

DIMENSIONS

Size	Code		D	Dk	E H8	R
	1 section coupling	2 sections coupling				
10	514178200P00	514378200P00	32	33	10	45
15	514178400P00	514378400P00	40	-	15	50
20	514178500P00	514378500P00	45	47	20	65
25	514178600P00	514378600P00	50	52	25	70
30	514178700P00	514378700P00	55	57	30	75
35	514178800P00	514378800P00	65	70	35	85
40	514178900P00	514378900P00	70	74	40	90
45	514179000P00	514379000P00	80	83	45	100
50	514179100P00	514379100P00	90	95	50	110

TECHNICAL CHARACTERISTICS

Size	Torque [Nm]	Weight [Kg]	Inertia [Kgm ²]	Max speed [Rpm]	Screws	Tightening torque screws [Nm]
10	18	0,25	0,000028	5500	n°4 x M4	3,1
15	40	0,42	0,000080	4200	n°4 x M5	6,2
20	70	0,65	0,000172	3800	n°4 x M6	10,5
25	85	0,87	0,000305	3500	n°4 x M6	10,5
30	95	1,11	0,000503	3200	n°4 x M6	10,5
35	205	1,75	0,001098	2700	n°4 x M8	25
40	225	2,13	0,001615	2500	n°4 x M8	25
45	250	2,96	0,002896	2200	n°4 x M8	25
50	450	4,31	0,005284	1900	n°4 x M10	50

GSF - bellow coupling: introduction



- Hubs made in aluminum fully turned and bellow in stainless steel.
- Suitable for applications with high temperatures (> 300 °C).
- High torsional rigidity and low inertia.
- Wear and maintenance free.
- Backlash free for precision and high speeds.
- Finished bore with ISO H8 tolerance and low roughness.

ON REQUEST

- Finished bore with keyway.
- Connection to the ComInTec backlash free torque limiter's range possible.
- Customized manufacturing for specific requirements.

The GSF bellow couplings have been designed and manufactured for all applications requiring excellent dynamic characteristics, necessary for high speeds, fast reversing and, at the same time, torsional rigidity with low inertia without compromising the high reliability.

The coupling is made in three different and modular elements, in order to obtain high flexibility in assembling and availability. The two shafts are connected to the bellow exploiting a simple mechanic system, easy and safe, by properly sized radial screws and without using bonding agents. In this way the coupling is able to operate and withstand high temperatures, up to 300 °C.

The coupling allows the compensation of all possible misalignments between the two shafts, to be connected in accordance to the values indicated in the table, assuring an infinite number of working cycles.

DIMENSIONING

The coupling's nominal torque must be higher than the maximum torque of the motor shaft, according to the generic formula on page 5. For further checks it is useful to verify: inertia on acceleration / deceleration, incorrect positioning in case of application when high precision is required, the natural frequency of the application (simplified system with two masses) according to formulas:

$$C_{nom} > C_{ad} \cdot K \cdot \frac{J_{uti}}{J_{mot} + J_{uti}}$$

$$\beta = \frac{180 \cdot C_{mot}}{\pi \cdot R_T}$$

$$f_e = \frac{1}{2\pi} \sqrt{R_T \cdot \frac{J_{uti} + J_{mot}}{J_{uti} \cdot J_{mot}}} > 2 \cdot f_{mot}$$

Where:

C_{nom} = nominal torque of the coupling [Nm]

C_{ad} = max value between acceleration torque on the motor side and deceleration torque on the user side [Nm]

C_{mot} = maximum torque on the motor side [Nm]

f_e = system frequency with two masses [Hz]

f_{mot} = frequency on the motor side [Hz]

J_{mot} = inertia on the motor side [Kgm²]

J_{uti} = inertia on the user side [Kgm²]

K = load factor

R_T = torsional rigidity of the coupling [Nm/rad]

β = rotation angle [°]

Load factor (K)

1,5	continuous load
2	discontinuous load
2÷3	machine tools
2,5 ÷ 4	shock load

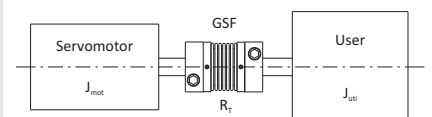

Simplified system with two masses

FITTING

It is advised to machine the connection's shafts with:

- Surface finish with Ra=1.6 µm.
- Coaxial precision 0.01 mm.
- Nominal tolerance h6.

At first, assemble the coupling by inserting the bellow into the relevant hubs and tighten the screws in sequence, respecting a cross sequence, continuously until you obtain the tightening torque indicated in the catalogue. Insert one hub on the first shaft along the N length and tighten the clamp locking screw with a torque wrench, respecting the tightening torque indicated on the catalogue. Leave the second shaft slides on the opposite hub along the whole N length and tighten the clamp locking screw with a torque wrench, respecting the tightening torque indicated on the catalogue.

It is important to consider that misalignments, axial, angular and parallel, must be considered paired together, as inversely proportional (one reduces when the other increases). If all types of misalignments occur, it is necessary that the sum in percentage respect to the maximum value doesn't exceed 100%.

If the metallic bellow is damaged, the whole coupling becomes unusable, so it is advised to be very careful in assembling and disassembling the individual components.

GSF - bellow coupling: technical data

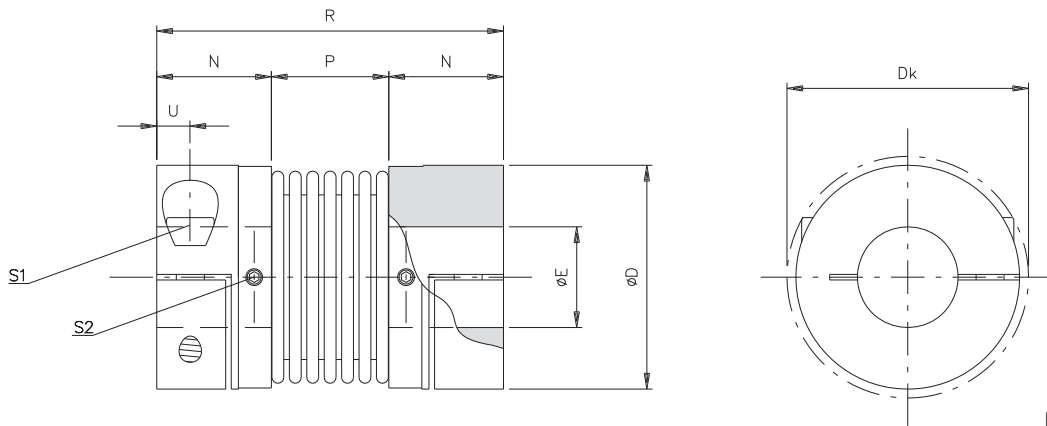

DIMENSIONS

Size	Code	D	Dk	E H7		N	P	R	U
				Min	Max				
1	2AA971nnnuuu	34	36	5	16	17	16,5	50,5	4,5
2	2AA972nnnuuu	40	44	8	20	20,5	21	62	5,5
3	2AA973nnnuuu	55	58	10	30	22,5	27	72	6,5
4	2AA974nnnuuu	65	73	14	38	26	32	84	8
5	2AA975nnnuuu	83	89	14	45	31	41	103	9,5

TECHNICAL CHARACTERISTICS

Size	Torque [Nm]		Weight [Kg]	Inertia [Kgm ²]	Max speed [Rpm]	Grubscrew S2	screw S1	Tightening torque [Nm]		Misalignments			Rigidity		
	Nom	Max						grubscrew S2	screw S1	angular α [°]	axial X [mm]	radial K [mm]	torsional R_t [Nm/rad • 10 ³]	axial R_a [N/mm]	radial R_r [N/mm]
1	5	10	0,07	0,000014	14000	M3	M4	2,9	0,8	1° 30'	±0,5	0,20	3,050	30	92
2	15	30	0,14	0,000032	12000	M3	M5	6	0,8	1° 30'	±0,6	0,20	7,000	45	129
3	35	70	0,29	0,000136	8500	M4	M6	10	2	2°	±0,8	0,25	16,300	69	160
4	65	130	0,45	0,000302	7000	M4	M8	25	2	2°	±0,8	0,25	33,000	74	227
5	150	300	0,93	0,001049	5500	M4	M10	49	2	2°	±1,0	0,30	64,100	87	480

TORQUE PERMISSIBLE WITH CLAMP LOCKING

Size	Torque transmitted [Nm] according to the ø finished bore [mm]																							
	5	6	7	8	9	10	11	12	14	15	16	18	19	20	24	25	28	30	32	35	38	40	42	45
1	5	6	7	8	9	10	11	12	14	15	16													
2				13	14	16	18	19	22	24	25	29	30	32										
3							25	27	32	34	36	41	43	45	54	57	63	68						
4												75	79	83	100	104	116	124	133	145	158			
5														132	158	165	183	198	211	231	248	263	277	295

APPLICATION EXAMPLE

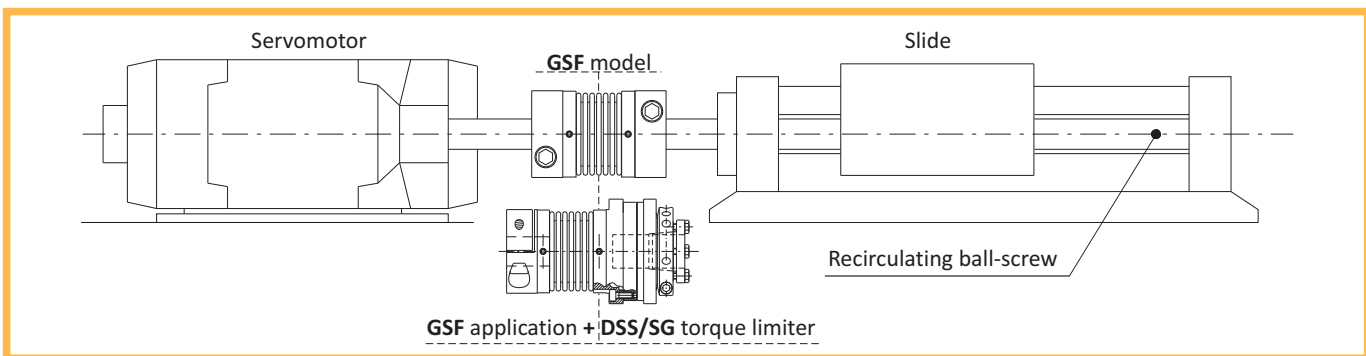

NOTES

- ⊗ **Code:** Item available only with finished bore. When ordering, please indicate on position "nnn" the finished bore of one hub, and on position "uuu" the finished bore of the second hub. Example: GSF size 1 finished bore ϕ 10-16 → 2AA971010016.
- ⊗ **Technical characteristics:** the weights refer to the coupling with minimum bore; inertias refer to the coupling with maximum bore.

GAS/SG - backlash free jaw coupling: introduction



- Made in steel fully turned with standard phosphating treatment.
- Several elastomer hardnesses available.
- High torsional rigidity.
- Electric insulation between the parts.
- Statically balanced.
- Version with integrated locking assemblies (GAS/SG/CCE).

ON REQUEST

- Conformity to Directive ATEX possible. 
- Specific surface treatments or version fully in stainless steel, aluminium, possible.
- Manufacturing made to length and customizations for specific needs.
- Connection to ComInTec TORQUE LIMITERS range possible.

The coupling GAS/SG is an elastomeric coupling with compact dimensions composed of two hubs made in steel UNI EN10083/98, fully turned and one elastomeric element.

The hub's tooth profile is designed to allow the elastomeric element to work only by compression and not in shear, allowing for long life of the coupling in high reversal or load applications.

The presence of the elastomer assures:

- the possibility to absorb collisions and vibrations;
- to compensate for unavoidable misalignments between the shafts;
- silence during transmission;

DESCRIPTION OF THE ELASTOMERIC ELEMENT

The fundamental item of this coupling is the elastomeric element or elastomer, made in polyurethane and available in several hardness grades, for different uses and applications. The elastomer is manufactured to resist ageing, scoring, fatigue, hydrolysis and UV radiations, promoting long life operation. Also resisting main chemical agents, like ozone, oils, grease and hydrocarbons.

The elastomeric element becomes prestressed during the assembly between the relevant hub's teeth, in order to be able to transmit the motion without backlash, so torsionally rigid inside the prestressing load. The prestressed elastomer's surface is sufficiently wide to induce a low contact pressure on the tooth of the same elastomer, reducing the permanent deformations, promoting a long life.

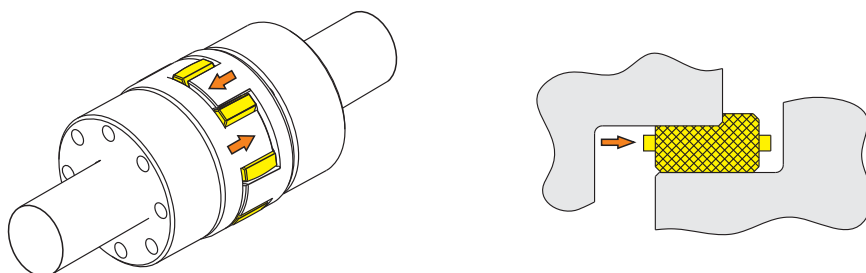

ATEX CONFORMITY



The GAS/SG coupling can be supplied in accordance to Directive 94/9/CE ATEX, which is relevant to protection apparatus and systems for use in potentially explosive spaces.

The dimensions of this coupling's version are not different from the standard version.

A mark relevant to the coupling's performances is printed on the hubs. It is necessary to consider planned tests, like described in the use and maintenance manual supplied together with each ATEX coupling.

The elastomeric elements used can be:

- red elastic element in polyurethane, 98 Shore-A : II 2 G D c T6 -20 ≤ Ta ≤ +60°C X U
- yellow elastic element in polyurethane, 92 Shore-A : II 2 G D c T5 -20 ≤ Ta ≤ +80°C X U

GAS/SG : backlash free jaw coupling: introduction

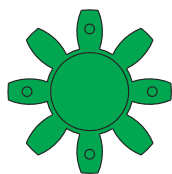
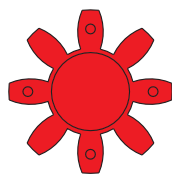
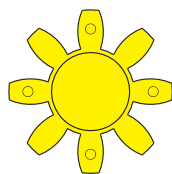

Elastomeric element **SG**
92 Sh-A

Elastomeric element **SG**
98 Sh-A

Elastomeric element **SG**
64 Sh-D

SG ELASTIC ELEMENT: TECHNICAL CHARACTERISTICS

Hardness [Shore]	Material	Color	Permitted temperature [°C]		Uses
			Working	For short period	
92 Sh-A	Polyurethane	Yellow	-40 ÷ +90	-50 ÷ +120	- low and medium power - measurement and control system - common electric motors
98 Sh-A	Polyurethane	Red	-30 ÷ +90	-40 ÷ +120	- high transmission torque - actuators, screwjacks - servomotors, right angle gearboxes
64 Sh-D	Polyurethane	Green	-20 ÷ +110	-30 ÷ +120	- high torsional rigidity - tool machines - internal combustion motors

SG ELASTOMERIC ELEMENT: PERFORMANCE CHARACTERISTICS

Size	Hardness [Sh]	Torque [Nm]		Misalignments			Rigidity		
		Nom	Max	angular α [°]	axial X [mm]	radial K [mm]	torsional R_t [Nm/rad • 10 ³]	axial R_a [N/mm]	radial R_r [N/mm]
01 (14/16)	92 Sh-A	7,5	15	1°	1	0,14	115	340	330
	98 Sh-A	12,5	25	0° 54'		0,09	170	510	650
	64 Sh-D	16	32	0° 48'		0,06	235	700	855
00 (19/24)	92 Sh-A	10	20	1°	1,2	0,10	680	1900	1200
	98 Sh-A	17	34	0° 54'		0,06	980	2300	2000
	64 Sh-D	21	42	0° 48'		0,04	1400	4280	2900
0 (24/28)	92 Sh-A	35	70	1°	1,4	0,14	1600	4410	1560
	98 Sh-A	60	120	0° 54'		0,10	2350	6300	2620
	64 Sh-D	75	150	0° 48'		0,07	3050	9600	3710
1 (28/38)	92 Sh-A	95	190	1°	1,5	0,15	2410	7060	2020
	98 Sh-A	160	320	0° 54'		0,11	3620	10900	3490
	64 Sh-D	200	400	0° 48'		0,08	4500	14500	4500
2 (38/45)	92 Sh-A	190	380	1°	1,8	0,16	5250	11950	2400
	98 Sh-A	325	650	0° 54'		0,12	7850	21850	4650
	64 Sh-D	405	810	0° 48'		0,09	9920	33600	6380
3 (42/55)	92 Sh-A	265	530	1°	2	0,18	6800	14700	2450
	98 Sh-A	450	900	0° 54'		0,15	18600	47500	5760
	64 Sh-D	560	1120	0° 48'		0,10	26400	71300	7570
4 (48/60)	92 Sh-A	310	620	1°	2,1	0,22	7800	18000	2850
	98 Sh-A	525	1050	0° 54'		0,16	20400	50600	6400
	64 Sh-D	655	1310	0° 48'		0,11	32400	96250	8900
5 (55/70)	98 Sh-A	685	1370	0° 54'	2,2	0,17	24200	61500	7150
6 (65/75)	98 Sh-A	1040	2080	0° 54'	2,6	0,18	38000	96500	6450

GAS/SG - backlash free jaw coupling: technical data

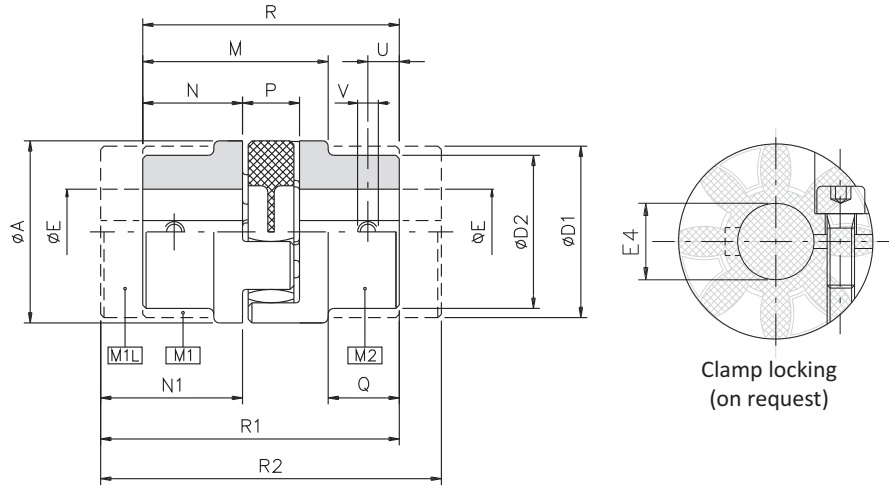

DIMENSIONS

Size	A	D1	D2	E H7 max	E4 H7 max	M	N	P	Q	R	T	U	V	N1	R1	R2
01 (14/16)	30	30	-	16	15	-	11	12	-	35	10	5	M4	18,5	42,5	50
00 (19/24)	40	40	32	25	20	-	25	16	16,5	66	18	10	M5	37	78	90
0 (24/28)	55	53	40	35	30	54	30	18	18,5	78	27	10	M5	50	98	118
1 (28/38)	65	63	48	40	35	62	35	20	24	90	30	15	M8	60	115	140
2 (38/45)	80	78	66	48	45	77	45	24	33	114	38	15	M8	70	139	164
3 (42/55)	95	93	75	55	50	86	50	26	38	126	46	20	M8	75	151	176
4 (48/60)	105	103	85	62	60	95	56	28	45	140	51	20	M8	80	164	188
5 (55/70)	120	118	98	74	65	108	65	30	49	160	60	20	M10	90	185	210
6 (65/75)	135	133	115	80	70	124	75	35	61	185	68	20	M10	100	210	235

TECHNICAL CHARACTERISTICS

Size	Torque [Nm]	Weight [Kg]			Inertia [Kgm ²]			Max speed [Rpm]	Clamp locking	
		M1	M2	Element	M1	M2	Element		Screw	Tightening torque [Nm]
01 (14/16)	See page 17	0,06	-	0,005	0,00001	-	0,0000005	25000	M4	3,1
00 (19/24)		0,2	0,2	0,009	0,00005	0,00003	0,000003	19000	M5	6,2
0 (24/28)		0,4	0,3	0,020	0,00020	0,00010	0,00001	13500	M6	10,5
1 (28/38)		0,7	0,5	0,030	0,00042	0,00022	0,00002	11800	M8	25
2 (38/45)		1,3	1,1	0,060	0,00131	0,00089	0,00005	9500	M8	25
3 (42/55)		1,9	1,8	0,980	0,00292	0,00232	0,00010	8000	M10	69
4 (48/60)		2,8	2,4	0,105	0,00483	0,00383	0,00020	7100	M12	120
5 (55/70)		4,0	3,8	0,150	0,00825	0,00740	0,00030	6300	M12	120
6 (65/75)		5,9	4,6	0,200	0,01682	0,01087	0,00050	5600	M12	120

TORQUE PERMISSIBLE WITH CLAMP LOCKING

Size	Torque transmitted [Nm] according to the ϕ finished bore [mm]																											
	6	8	10	11	12	14	15	16	18	19	20	22	24	25	28	30	32	35	38	40	42	45	48	50	55	60	65	70
01 (14/16)	6	7	8	8	9	10	10																					
00 (19/24)			21	21	22	22	23	23	24	25	25																	
0 (24/28)					43	44	44	45	46	47	47	49	50	51	53	54												
1 (28/38)								90	91	92	95	97	98	102	104	107	110											
2 (38/45)											109	111	113	114	118	120	123	126	130	133	135	139						
3 (42/55)														260	267	272	276	284	291	296	301	308	316	321				
4 (48/60)																		449	456	463	474	484	491	509	528			
5 (55/70)																				508	519	530	537	555	573	591		
6 (65/75)																						564	575	582	600	618	636	654

NOTE

⊗ Technical characteristics: the weights refer to the coupling with pilot bore; inertias refer to the coupling with maximum bore.

GAS/SG/CCE - backlash free jaw coupling with external locking assembly: technical data

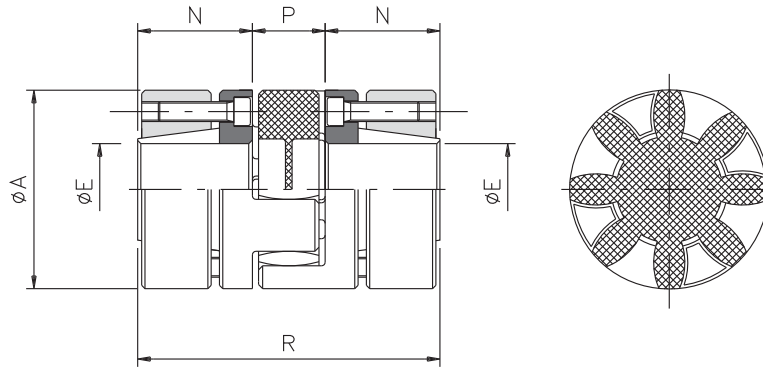

DIMENSIONS

Size	Code	A	D	E H7		N	P	R	T
				min	max				
01 (14/16)	2QQ797nnnnuuu	30	30	6	16	11	13	35	10
00 (19/24)	2QQ807nnnnuuu	40	40	10	20	25	16	66	18
0 (24/28)	2QQ817nnnnuuu	55	55	15	28	30	18	78	27
1 (28/38)	2QQ827nnnnuuu	65	65	19	38	35	20	90	30
2 (38/45)	2QQ837nnnnuuu	80	80	20	48	45	24	114	38
3 (42/55)	2QQ847nnnnuuu	95	95	28	55	50	26	126	46
4 (48/60)	2QQ857nnnnuuu	105	105	35	62	56	28	140	51
5 (55/70)	2QQ867nnnnuuu	120	120	35	70	65	30	160	60
6 (65/75)	2QQ877nnnnuuu	135	135	40	75	75	35	185	68

TECHNICAL CHARACTERISTICS

Size	Weight [Kg]		Inertia [Kgm ²]		Max speed [Rpm]	Screw UNI 5931	Tightening screw torque [Nm]
	M1	Element	M1	Element			
01 (14/16)	0,06	0,005	0,00001	0,0000005	25000	n°4 x M2,5	0,75
00 (19/24)	0,2	0,009	0,00005	0,000003	19000	n°6 x M4	3
0 (24/28)	0,4	0,020	0,00020	0,00001	13500	n°4 x M5	6
1 (28/38)	0,7	0,030	0,00042	0,00002	11800	n°8 x M5	6
2 (38/45)	1,3	0,060	0,00131	0,00005	9500	n°8 x M6	10
3 (42/55)	1,9	0,980	0,00292	0,00010	8000	n°4 x M8	35
4 (48/60)	2,8	0,105	0,00483	0,00020	7100	n°4 x M8	35
5 (55/70)	4,0	0,150	0,00825	0,00030	6300	n°4 x M10	69
6 (65/75)	5,9	0,200	0,01682	0,00050	5600	n°4 x M12	120

TORQUE PERMISSIBLE WITH EXTERNAL LOCKING ASSEMBLIES

Grand.	Torque transmitted [Nm] according to the ϕ finished bore [mm]																											
	6	10	11	14	15	16	17	18	19	20	22	24	25	28	30	32	35	38	40	42	45	48	50	55	60	65	70	75
01 (14/16)	7	12	13	17	18	20																						
00 (19/24)	48	53	67	72	77	81	86	91	96																			
0 (24/28)				77	82	88	93	98	103	113	124	129	144															
1 (28/38)							186	196	206	227	247	258	289	309	330	361	392											
2 (38/45)									291	320	349	364	408	437	466	510	553	582	612	655	699							
3 (42/55)												345	584	623	681	740	779	818	876	934	973	1071						
4 (48/60)																681	740	779	818	876	934	973	1071	1168				
5 (55/70)																1091	1184	1247	1309	1402	1496	1558	1714	1870	2026	2182		
6 (65/75)																		1852	1944	2083	2222	2315	2546	2778	3009	3241	3472	

NOTES

- ⊗ **Code:** Item available only with finished bore. When ordering, please indicate on position "nnn" the finished bore of one hub, and on position "uuu" the finished bore of the second hub. Example: GAS/SG/CCE size 1 finished bore ϕ 28-36 → 2QQ827028036.
- ⊗ **Technical characteristics:** the weights refer to the coupling with minimum bore; inertias refer to the coupling with maximum bore.

GAS - jaw coupling: introduction



- Made in steel fully turned with standard phosphating treatment.
- Several elastomer hardnesses available.
- High compensation of misalignments.
- Vibration dampening.
- Statically balanced.
- Modularity of the components, with different assembly versions.

ON REQUEST

- Conformity to directive ATEX possible. 
- Specific treatments or version fully in stainless steel, aluminium, possible.
- Manufacturing made to length and customizations for specific needs.
- Connection to ComInTec TORQUE LIMITERS range possible.

The coupling GAS/SG is an elastomeric coupling with compact dimensions composed of two hubs made in steel UNI EN10083/98, fully turned with one elastomer.

The hub's tooth profile is designed to allow the elastomeric element to work only by compression and not in shear, allowing for long life of the coupling in high reversal or load applications.

The GAS base series are available in several hub versions to allow an assembly to suit the application.

- M1 hub base hub for any kind of connection
- M1L extended hub to connect long shafts
- M2 hub with reduced external diameter for assembly in compact spaces.
- F flange for connection shaft-flange
- Customized spacer for connection of distant shafts

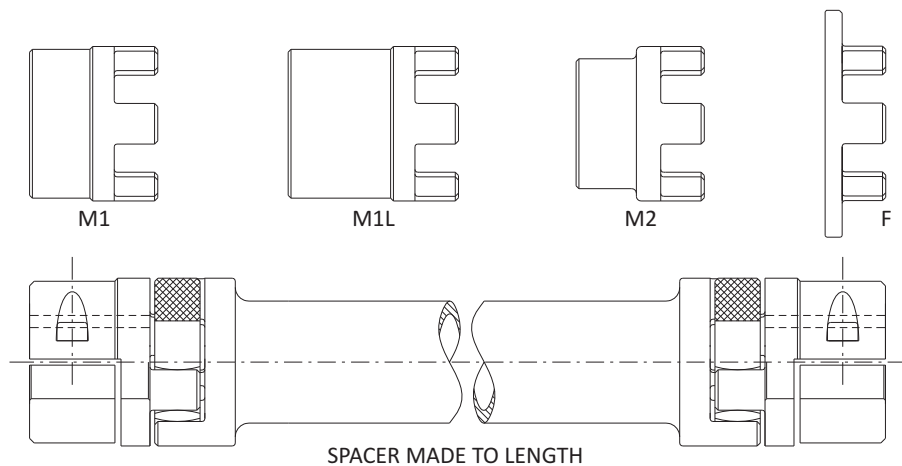

DESCRIPTION OF THE ELASTOMERIC ELEMENT

The fundamental item of this coupling is the elastomeric element, made in different grades of hardness for different needs and applications. The elastomer is manufactured from elements to resist ageing, scoring, fatigue, hydrolysis and UV radiations, promoting long life operation, resisting main chemical agents, like ozone, oils, greases and hydrocarbons.

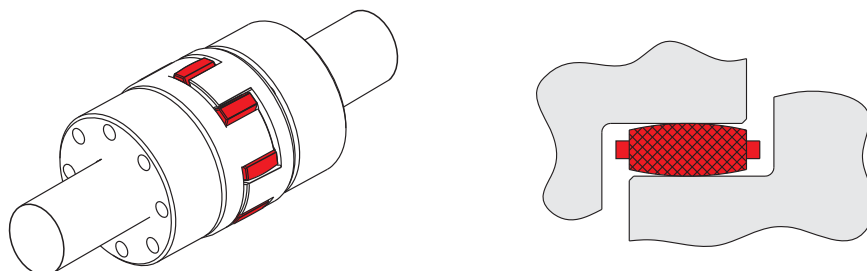

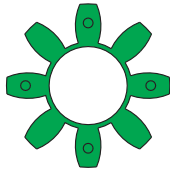
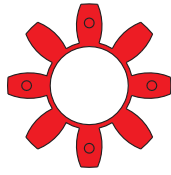
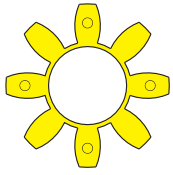

Elastomeric element
92 Sh-A

Elastomeric element
98 Sh-A

Elastomeric element
64 Sh-D

ELASTOMERIC ELEMENT: TECHNICAL CHARACTERISTICS

Hardness [Shore]	Material	Color	Allowed temperature [°C]		Uses
			Working	For short periods	
92 Sh-A	Polyurethane	Yellow	-40 ÷ +90	-50 ÷ +120	- low and medium power - systems with frequent stop, starts
98 Sh-A	Thermoplastic	Red	-40 ÷ +125	-50 ÷ +150	- high transmission torque - high temperature range
64 Sh-D	Polyurethane	Green	-20 ÷ +110	-30 ÷ +120	- high torsional rigidity - internal combustion motors

ELASTOMERIC ELEMENT: PERFORMANCE CHARACTERISTICS

Size	Hardness [Sh]	Torque [Nm]			Misalignments			Rigidity R _T [Nm/rad•10 ³]			
		Nom	Max	Alternate motion	angular α [°]	axial X [mm]	radial K [mm]	25% nom torque	50% nom torque	75% nom torque	100% nom torque
00 (19/24)	92 Sh-A	10	20	2,6	1° 18'	1,0	0,4	0,62	0,73	0,93	1,18
	98 Sh-A	17	34	4,4				0,92	1,14	1,33	1,49
	64 Sh-D	21	42	5,5				1,97	3,33	4,40	5,37
0 (24/28)	92 Sh-A	35	70	9	1° 18'	1,0	0,8	2,44	2,71	3,66	4,43
	98 Sh-A	60	120	16				3,64	4,74	5,47	5,92
	64 Sh-D	75	150	19,5				5,50	9,35	12,40	15,10
1 (28/38)	92 Sh-A	95	190	25	1° 18'	1,2	1,0	4,10	5,73	6,62	7,65
	98 Sh-A	160	320	42				6,08	7,82	8,88	10,68
	64 Sh-D	200	400	52				10,10	17,00	22,55	27,50
2 (38/45)	92 Sh-A	190	380	49	1° 18'	1,4	1,0	8,69	10,75	12,55	14,57
	98 Sh-A	325	650	85				10,95	14,13	18,25	21,90
	64 Sh-D	405	810	105				25,75	43,50	57,50	70,10
3 (42/55)	92 Sh-A	265	530	69	1° 18'	1,6	1,0	11,52	14,66	17,27	21,50
	98 Sh-A	450	900	117				16,34	21,41	25,17	30,29
	64 Sh-D	560	1120	145				29,30	49,50	65,45	79,85
4 (48/60)	92 Sh-A	310	620	81	1° 18'	1,7	1,4	11,85	18,72	21,34	24,52
	98 Sh-A	525	1050	137				17,97	24,39	27,68	34,14
	64 Sh-D	655	1310	170				35,10	59,20	78,30	95,50
5 (55/70)	92 Sh-A	410	820	105	1° 18'	1,8	1,4	16,63	26,27	29,94	34,42
	98 Sh-A	685	1370	178				24,88	33,77	38,33	47,27
	64 Sh-D	825	1650	215				39,65	66,90	88,55	107,90
6 (65/75)	92 Sh-A	625	1250	163	1° 18'	2,0	1,4	27,14	38,00	40,71	50,67
	98 Sh-A	940	1880	245				36,00	48,01	55,55	66,47
	64 Sh-D	1175	2350	305				55,54	93,65	124,00	150,10
7 (75/90)	92 Sh-A	975	1950	254	1° 18'	2,5	1,8	54,17	70,10	89,38	103,63
	98 Sh-A	1465	2930	381				72,52	92,30	112,81	123,07
	64 Sh-D	2410	4820	625				91,21	153,87	203,51	249,12
8 (90/100)	92 Sh-A	2400	4800	624	1° 18'	2,8	1,8	88,99	113,90	164,29	177,98
	98 Sh-A	3600	7200	936				127,47	172,99	201,82	230,65
	64 Sh-D	4500	9000	1170				246,85	415,53	550,13	672,87

GAS - jaw coupling: technical data

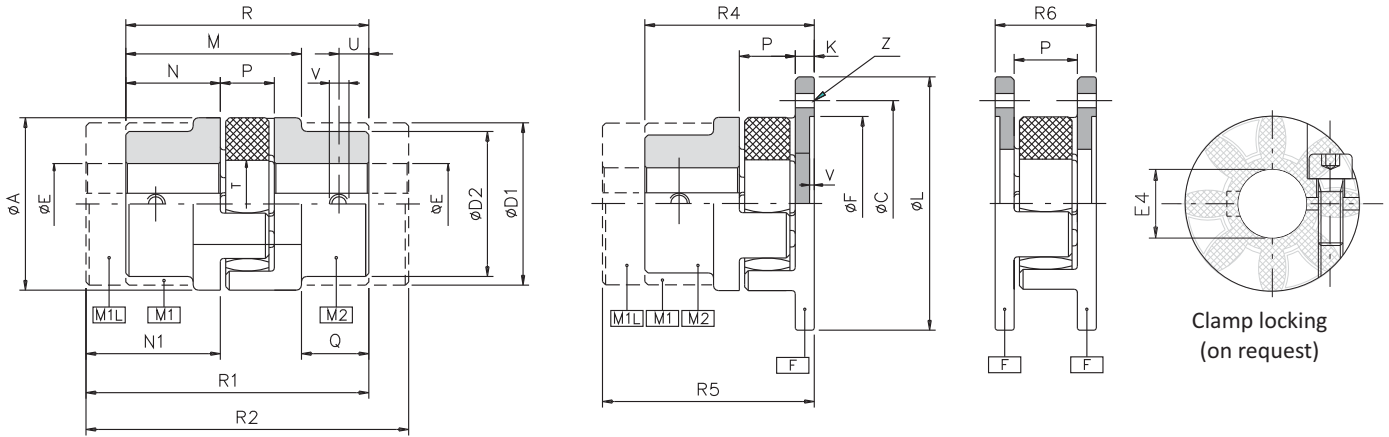

DIMENSIONS

Size	A	D1	D2	E H7 max	E4 H7 max	M	N	P	Q	R	T	U	V	N1	R1	R2	C	F H7	G	L	K	R4	R5	Z	R6
00 (19/24)	40	40	32	25	20	-	25	16	16,5	66	18	10	M5	37	78	90	50	40	1,5	58	8	49	61	n°5 x ø4,5	32
0 (24/28)	55	53	40	35	30	54	30	18	18,5	78	27	10	M5	50	98	118	65	55	1,5	74	8	56	76	n°5 x ø4,5	34
1 (28/38)	65	63	48	40	35	62	35	20	24	90	30	15	M8	60	115	140	80	65	1,5	92	10	65	90	n°6 x ø6,6	40
2 (38/45)	80	78	66	48	45	77	45	24	33	114	38	15	M8	70	139	164	95	80	1,5	107	10	79	104	n°6 x ø6,6	44
3 (42/55)	95	93	75	55	50	86	50	26	38	126	46	20	M8	75	151	176	115	95	2	132	12	88	113	n°6 x ø9	50
4 (48/60)	105	103	85	62	60	95	56	28	45	140	51	20	M8	80	164	188	125	105	2	142	12	96	122	n°8 x ø9	52
5 (55/70)	120	118	98	74	65	108	65	30	49	160	60	20	M10	90	185	210	145	120	2	164	16	111	136	n°8 x ø11	62
6 (65/75)	135	133	115	80	70	124	75	35	61	185	68	20	M10	100	210	235	160	135	2	179	16	126	153	n°10 x ø11	67
7 (75/90)	160	158	135	95	-	141	85	40	69	210	80	25	M10	110	235	260	185	160	2,5	208	19	144	169	n°10 x ø14	78
8 (90/100)	200	180	160	110	-	164	100	45	81	245	100	30	M12	125	270	295	225	200	3	248	20	165	190	n°12 x ø14	85

TECHNICAL CHARACTERISTICS

Size	Torque [Nm]	Weight [Kg]				Inertia [Kgm²]				Max speed [Rpm]	Clamp locking	
		M1	M2	F	Element	M1	M2	F	Element		Screw	Tightening torque [Nm]
00 (19/24)	see page 21	0,2	0,2	0,1	0,009	0,00005	0,00003	0,00007	0,000003	19000	M5	6,2
0 (24/28)		0,4	0,3	0,3	0,020	0,00020	0,00010	0,00014	0,00001	13500	M6	10,5
1 (28/38)		0,7	0,5	0,6	0,030	0,00042	0,00022	0,00044	0,00002	11800	M8	25
2 (38/45)		1,3	1,1	0,9	0,060	0,00131	0,00089	0,00121	0,00005	9500	M8	25
3 (42/55)		1,9	1,8	1,6	0,090	0,00292	0,00232	0,00246	0,00010	8000	M10	69
4 (48/60)		2,8	2,4	1,8	0,105	0,00483	0,00383	0,00302	0,00020	7100	M12	120
5 (55/70)		4,0	3,8	3,0	0,150	0,00825	0,00740	0,00603	0,00030	6300	M12	120
6 (65/75)		5,9	4,6	3,7	0,200	0,01682	0,01087	0,00912	0,00050	5600	M12	120
7 (75/90)		9,1	7,2	5,2	0,380	0,03933	0,02333	0,02110	0,00200	4750	-	-
8 (90/100)		17,0	12,5	8,3	0,650	0,10936	0,06036	0,07019	0,00400	3750	-	-

TORQUE PERMISSIBLE WITH CLAMP LOCKING

Size	Torque transmitted [Nm] according to the ø finished bore [mm]																												
	6	8	10	11	12	14	15	16	18	19	20	22	24	25	28	30	32	35	38	40	42	45	48	50	55	60	65	70	
00 (19/24)			21	21	22	22	23	23	24	25	25																		
0 (24/28)					43	44	44	45	46	47	47	49	50	51	53	54													
1 (28/38)									90	91	92	95	97	98	102	104	107	110											
2 (38/45)											109	111	113	114	118	120	123	126	130	133	135	139							
3 (42/55)															260	267	272	276	284	291	296	301	308	316	321				
4 (48/60)																			449	456	463	474	484	491	509	528			
5 (55/70)																					508	519	530	537	555	573	591		
6 (65/75)																						564	575	582	600	618	636	654	

GAS and GAS/SG - jaw coupling: additional information

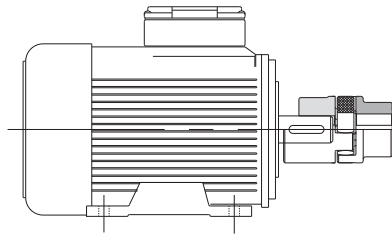

MOTORS ■

Electric motor		750 rpm					1000 rpm					1500 rpm					3000 rpm				
Size	Shaft	P (Kw)	C (Nm)	GAS			P (Kw)	C (Nm)	GAS			P (Kw)	C (Nm)	GAS			P (Kw)	C (Nm)	GAS		
				92 Sh-A	98 Sh-A	64 Sh-D			92 Sh-A	98 Sh-A	64 Sh-D			92 Sh-A	98 Sh-A	64 Sh-D			92 Sh-A	98 Sh-A	64 Sh-D
63	ø11x23	-	-	-	-	-	0,06	0,7	01	01	01	0,12	0,88	01	01	01	0,18	0,62	01	01	01
		-	-	-	-	-	0,09	1,1				0,18	1,30				0,25	0,86			
71	ø14x30	0,09	1,4	01	01	01	0,18	2,0	01	01	01	0,25	1,80	01	01	01	0,37	1,30	01	01	01
		0,12	1,8				0,25	2,8				0,37	2,50				0,55	1,90			
80	ø19x40	0,18	2,5	00	00	00	0,37	3,9	00	00	00	0,55	3,70	00	00	00	0,75	2,50	00	00	00
		0,25	3,5				0,55	5,8				0,75	5,10				1,10	3,70			
90 S	ø24x50	0,37	5,3	00	00	00	0,75	8,0	00	00	00	1,10	7,50	00	00	00	1,50	5,00	00	00	00
90 L	ø24x50	0,55	7,9	00	00	00	1,10	12	0	0	0	1,50	10	00	00	00	2,20	7,40	00	00	00
100 L	ø28x60	0,75	11	0	0	0	1,50	15	0	0	0	2,20	15	0	0	0	3,00	9,80	0	0	0
		1,10	16									3,00	20								
112 M	ø28x60	1,50	21	0	0	0	2,20	22	0	0	0	4,00	27	0	0	0	4,00	13	0	0	0
132 S	ø38x80	2,20	30	1	1	1	3,00	30	1	1	1	5,50	36	1	1	1	5,50	18	1	1	1
																	7,50	25			
132 M	ø38x80	3,00	40	1	1	1	4,00	40	1	1	1	7,50	49	1	1	1	-	-	-	-	-
							5,50	55									-	-			
160 M	ø42x110	4,00	54	2	2	2	7,50	75	2	2	2	11,00	72	2	2	2	11,00	35	2	2	2
		5,50	74														15,00	49			
160 L	ø42x110	7,50	100	2	2	2	11,00	109	2	2	2	15,00	98	2	2	2	18,50	60	2	2	2
180 M	ø48x110	-	-	-	-	-	-	-	-	-	-	18,50	121	2	2	2	22	71	2	2	2
180 L	ø48x110	11,00	145	2	2	2	15,00	148	3	2	2	22	144	2	2	2	-	-	-	-	-
200 L	ø55x110	15,00	198	3	3	3	18,50	181	3	3	3	30	196	3	3	3	30	97	3	3	3
							22,00	215									37	120			
225 S	ø55x110 ø60x140	18,50	244	4	3	3	-	-	-	-	-	37	240	4	3	3	-	-	-	-	-
				4	4	4								4	4	4					
225 M	ø55x110 ø60x140	22	290	4	3	3	30	293	4	3	3	45	292	4	3	3	45	145	3	3	3
				4	4	4			4	4	4			3	4	4					
250 M	ø60x140 ø65x140	30	392	6	4	4	37	361	5	4	4	55	356	5	4	4	55	177	4	4	4
				6	5	5			5	5	5			4	5	5					
280 S	ø65x140 ø75x140	37	483	6	5	5	45	438	6	5	5	75	484	6	5	5	75	241	5	5	5
280 M	ø65x140 ø75x140	45	587	6	5	5	55	535	6	5	5	90	581	6	5	5	90	289	5	5	5
				6	6	6			6	6	6			5	6	6					
315 S	ø65x140 ø80x170	55	712	7	6	6	75	727	7	6	5	110	707	7	6	5	110	353	5	5	5
				7	6	6			7	6	6			5	6	6					
315 M	ø65x140 ø80x170	75	971	8	7	7	90	873	7	6	5	132	849	7	6	6	132	423	6	5	5
				7	6	6			6	6	6			6	6	6					
315 L	ø65x140 ø80x170 ø85x170	90	1170	8	7	7	110	1070	8	7	7	160	1030	8	7	7	160	513	6	5	5
		110	1420	8	8	8	132	1280	8	7	7	200	1290				200	641	7	6	6
		132	1710	8	8	8	160	1550	8	8	7	-	-				-	-	-	-	-
315	ø65x140 ø85x170	160	2070	8	8	8	200	1930	8	8	7	250	1600	8	8	7	250	802	7	6	6
		200	2580	-	8	8	250	2410	8	8	8	315	2020				315	1010	8	7	6
355	ø75x140 ø95x170	-	-	-	-	-	-	-	-	-	-	355	2280	-	8	8	355	1140	8	7	7
		250	3220	-	8	8	315	3040	-	8	8	400	2570	-	8	8	400	1280	8	7	7
		315	4060	-	-	8	400	3850	-	-	8	500	3210	-	8	8	500	1600	8	8	7
400	ø80x170 ø110x210	355	4570	-	-	-	450	4330	-	-	-	560	3580	-	-	8	560	1790	8	8	7
		400	5150	-	-	-	500	4810	-	-	-	630	4030	-	-	8	630	2020			

GAS & GAS/SG - jaw coupling: additional information

DIMENSIONING

For pre-selection of the coupling's size you can use the generic formula indicated on page 5.

Having established the coupling's size to be used, it is possible to make other checks considering further parameters:

$$C_{nom} > C_{mot} \cdot f_T \cdot f_R$$

Considering the static torque:

$$C_{max} > C_{SM} \cdot \frac{J_{uti}}{J_{uti} + J_{mot}} \cdot K \cdot f_T \cdot f_A + C_{mot} \cdot f_T \cdot f_R$$

$$C_{max} > C_{SU} \cdot \frac{J_{mot}}{J_{uti} + J_{mot}} \cdot K \cdot f_T \cdot f_A + C_{mot} \cdot f_T \cdot f_R$$

Where:

- C_{nom} = theoretic nominal torque of the coupling [Nm]
- C_{mot} = nominal torque motor side [Nm]
- C_{max} = maximum torque of the coupling [Nm]
- C_{SU} = static torque user side [Nm]
- C_{SM} = static torque motor side [Nm]
- f_A = starting frequency factor
- f_R = rigidity factor
- f_T = thermic factor
- J_{mot} = inertia motor side [Kgm²]
- J_{uti} = inertia user side [Kgm²]
- K = shock factor

In case of alternate motion,

$$C_{nom} > \frac{1}{M} \cdot C_{alt} \cdot f_f \cdot f_T \cdot f_R$$

Where:

- C_{alt} = alternate system torque [Nm]
- C_{nom} = theoretic nominal torque of the coupling [Nm]
- f_f = resonance factor
- f_R = rigidity factor
- f_T = thermic factor
- M = coefficient of material

Coefficient of material (M)	
0,25	aluminium
0,35	steel

Resonance factor (f _f)	
1	frequency < 10
$\sqrt{\frac{f}{10}}$	frequency > 10

Rigidity factor (f _R)	
2÷5	positioning system
3÷8	tool machines
>10	turn indicators

Shock factor (K)	
1	light shock
1,4	medium shock
1,8	hard shock

Thermic factor (f _T)	
1	-30 ÷ +30 °C
1,2	> +30 ÷ +40 °C
1,4	> +40 ÷ +60 °C
1,8	> +60 ÷ +80 °C

Starting frequency factor (f _A)	
1	0 ÷ 100 starting each hour
1,2	> 100 ÷ 200 starting each hour
1,4	> 200 ÷ 400 starting each hour
1,6	> 400 ÷ 800 starting each hour
1,8	> 800 ÷ 1600 starting each hour

APPLICATION EXAMPLE

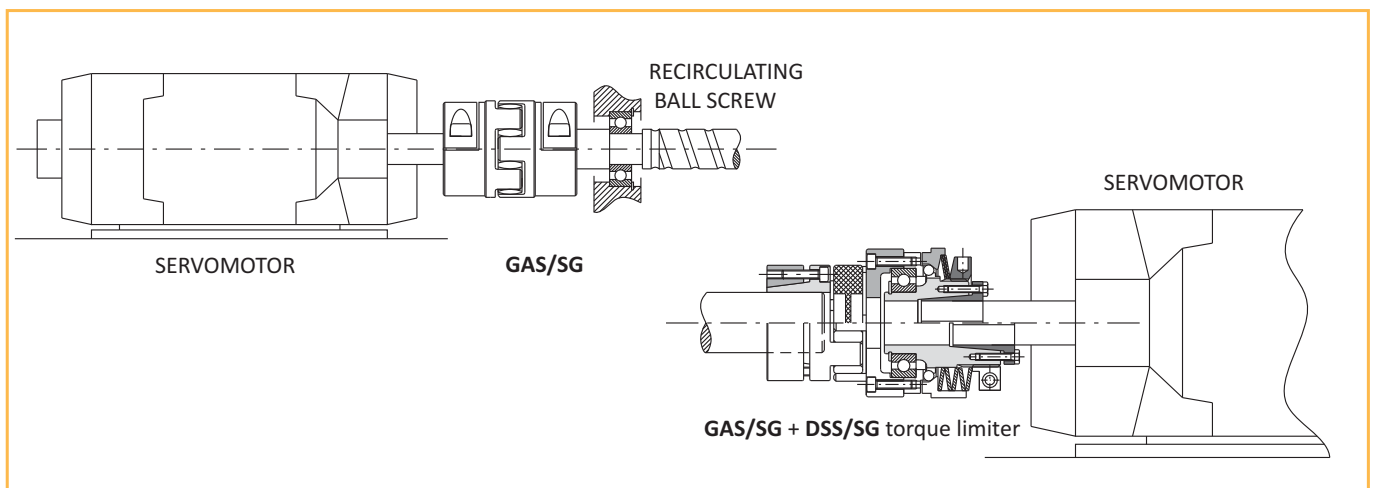

Having completed and checked the coupling choice, in accordance to the torque to be transmitted, it is necessary now to take into consideration the necessary flexibility comparing the misalignments allowed from the kind of coupling selected, with the real ones, seen by the shafts to be connected.

It is important to consider that misalignments, axial, angular and parallel, must be considered paired together, as inversely proportional (one reduces when the other increases). If all types of misalignments occur, it is necessary that the sum in percentage respect to the maximum value doesn't exceed 100%, according to "graphic 1".

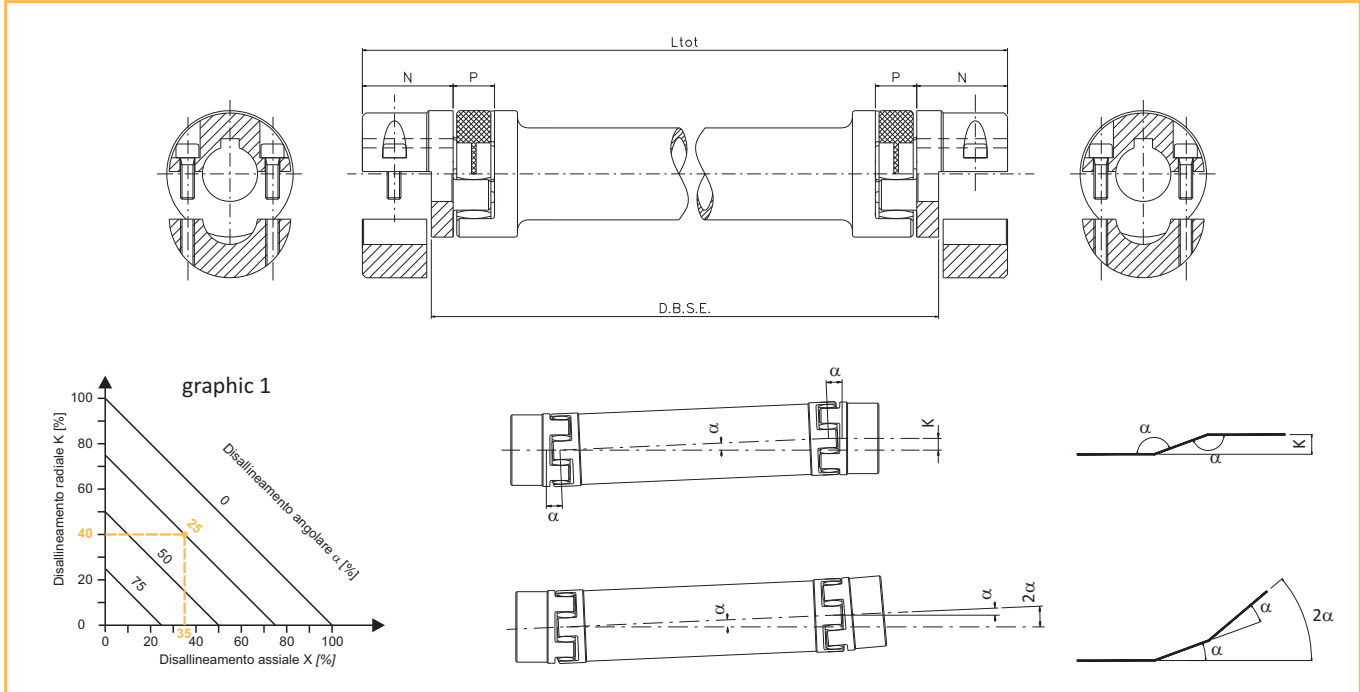

$$K = [L_{tot} - (2 \cdot N) - P] \cdot \text{Tg } \alpha$$

Dove:

- L_{tot} = total length [mm]
- K = radial misalignment [mm]
- N = useful length of an half-hub [mm]
- P = useful space of the elastomeric element [mm]
- α = angular misalignment [°]

FITTING

Particular procedures to assemble this coupling are not required. It can be assembled both vertically and horizontally.

- 1) Achieve radial and axial alignments as precisely as possible, to have maximum absorption of possible misalignments and life of the coupling.
- 2) Assemble the two half-hubs on the shafts. Check that the external parts of the two shafts do not exceed the relevant half-hub's surface (quote "N") and fix this one to the shaft with its relevant fixing system.
- 3) Assemble the elastomeric element on one half-hub and close the other inserting the relevant teeth into the elastomeric element, being careful to respect the distance of the two half-hubs indicated on the catalogue, quote "P".

In case of connection by clamp locking or locking assemblies, tighten the relevant screws progressively up to the tightening torque indicated in the catalogue, using a cross sequence.

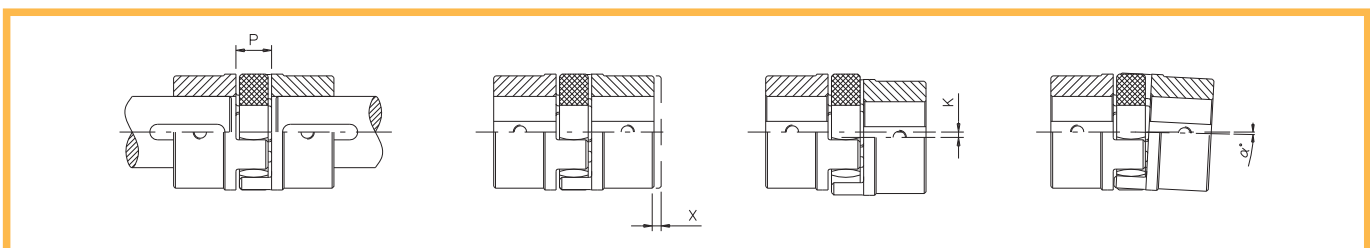

GEC - compact elastic coupling: introduction

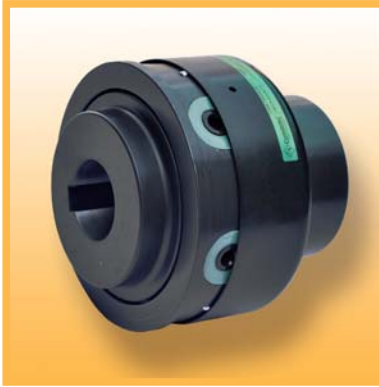

- Made in steel fully turned with standard treatment of phosphating.
- Maintenance possible without moving hubs.
- Suitable for high operating temperature.
- Statically balanced and vibration dampening
- Maximum grade of protection.
- Optimum ratio of torque / dimensions.

ON REQUEST

- Two different elastomeric elements types for different temperatures.
- Specific surface treatments or in aluminium fully turned version possible.
- Customized manufacturing for specific needs, hub-flange or flange-flange.
- Connection to ComInTec TORQUE LIMITERS range possible.

The GEC coupling is composed of two hubs in steel UNI EN10083/98 fully turned. These two hubs are connected by radial pins, made in steel with high resistance and seated within the elastomeric elements.

These pins, with their relevant elastomeric elements, are protected by an external band, allowing the coupling a high grade of protection. This construction feature allows the user to be able to perform maintenance, by substituting the elastic elements, without the need to move the two transmission hubs/shafts, reducing maintenance times and optimizing the plant productivity.

Particularly suitable to connect Pelton turbines, for the coupling between engines and worm compressors and in general for transmission where safety is highly required without compromising the quality and effectiveness of the same transmission.

DESCRIPTION OF THE ELASTOMERIC ELEMENT

Two different kind of elastomeric element are available, distinguished by the colour. The main features are:

- Good resistance to all common lubricants and hydraulic fluids.
- Optimum mechanical properties.
- Green element suitable to operate for short periods up to 170 °C.

DIMENSIONING

For pre-selection of the coupling's size you can use the generic formula indicated on page 5.

Alternatively it is possible to determine the coupling's nominal torque using several correction factors:

$$C_{nom} > C_{mot} \cdot f \cdot K \cdot f_T \cdot f_A$$

Where:

C_{nom} = theoretic nominal torque of the coupling [Nm]
 C_{mot} = nominal torque motor side [Nm]
 f = service factor (vedi pagina 5)
 f_A = starting frequency factor
 f_T = thermic factor
 K = shock factor

Thermic factor (f_T)	
1	-36 ÷ 60 °C
1,2	> 80 °C
1,4	> 100 °C
1,6	> 120 °C

Shock factor (K)	
1,2	light shock
1,5	medium shock
1,8	hard shock

Starting frequency factor (f_A)	
1	0 ÷ 120 starting each hour
1,2	> 120 ÷ 240 starting each hour
1,4	> 240 ÷ 400 starting each hour
1,6	> 400 ÷ 800 starting each hour

Having completed and checked the coupling's choice, in accordance to the torque to be transmitted, it is necessary now, to take into consideration, the necessary flexibility comparing the misalignments allowed from the kind of coupling selected, with the real ones, seen by the shafts to be connected.

It is important to consider that misalignments, axial, angular and parallel, must be considered paired together, as inversely proportional (one reduces when the other increases). If all types of misalignments occur, it is necessary that the sum in percentage respect to the maximum value doesn't exceed 100%.

FITTING

Specific procedures to assemble this coupling are not required.

- 1) Achieve radial and axial alignment as precisely as possible for maximum absorption of possible misalignments and the maximal duration of the coupling.
- 2) Having the coupling pre-assembled, insert the external half-hub on one shaft. Check that the external parts of the two shafts don't exceed the relevant half-hub's surface (quote "N") and fix this one to the shaft with its relevant fixing system.
- 3) Close the second shaft inserting it into the internal half-hub for a quantity not higher than the length of the bore (quote "N"). If the insertion should be difficult, due to an accentuated misalignment, it is opportune to release all the connection pins, obtaining in this way a higher flexibility between the two half-hubs.
- 4) After having inserted and fixed the hubs, take away each connection pin, damp them with loctite threadlocker, and reassemble and tighten them carefully in progressive way following a cross sequence.
- 5) Cover the pins with the protection band, making the holes of the band coincide with the relevant locking spheres.

GEC - compact elastic coupling: technical data:

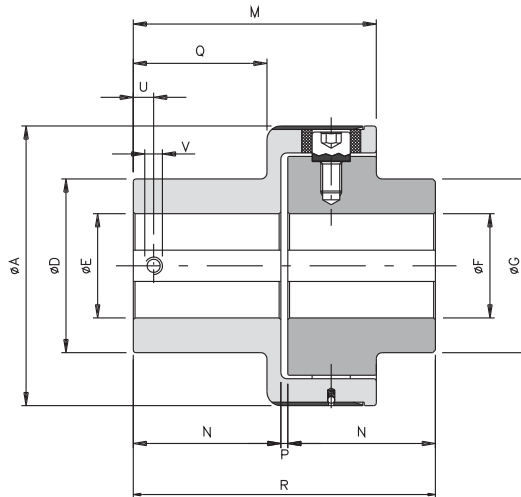

DIMENSIONS

Size	Code		A	D	E H7		F H7		G	M	N	P	Q	R	U	V
	Coupling with BLACK element	Coupling with GREEN element			pilot	max	pilot	max								
00	200650000000	200655000000	63	42	5	20	5	20	42	52	25	3.5	18	61,5	8	M4
0	200660000000	200665000000	78	50	10	28	10	28	50	63.5	32	3.5	28	67,5	10	M5
1	200670000000	200675000000	108	70	12	38	12	38	70	89	49	4	44	102	12	M6
2	200680000000	200685000000	130	80	15	45	15	45	80	111	65	4	59	134	15	M8
3	200690000000	200695000000	161	100	15	60	15	60	100	140	85	4	77	174	15	M8
4	200700000000	200705000000	206	120	20	70	20	70	120	168	105	4	97	214	20	M10
5	200710000000	200715000000	239	135	30	80	30	80	135	201	130	4	120	264	20	M10
6	-	200725000000	315	215	40	150	40	110	175	260	165	5	150	335	25	M12
7	-	200735000000	364	240	40	180	40	140	210	310	205	5	185	415	25	M12

TECHNICAL CHARACTERISTICS

Size	Torque [Nm]		Weight [Kg]	Inertia [Kgm ²]	Max speed [Rpm]	Max temperature [°C]		Elastic element hardness [Sh-A]	Misalignments					
	Nom	Max				BLACK elastic element	GREEN elastic element		angular α [°]		axial X [mm]		radial K [mm]	
									continuous	intermittent	continuous	intermittent	continuous	intermittent
00	35	50	0,8	0,00045	6000	100 ±10	170 ±10	80	1°	1° 30'	±0,7	±1,5	0,5	0,7
0	70	110	1,5	0,00124	5500				1°	1° 30'	±0,7	±1,5	0,5	0,7
1	280	420	4,2	0,00633	5000				0° 48'	1°	±0,7	±1,5	0,5	0,7
2	570	860	7,7	0,01592	4500				0° 36'	0° 48'	±0,7	±1,5	0,6	0,7
3	980	1500	14,2	0,04666	4000				0° 30'	0° 42'	±0,8	±1,6	0,6	0,8
4	2340	3600	22,6	0,12546	3100				0° 24'	0° 30'	±0,8	±1,6	0,6	0,8
5	3880	5800	36,0	0,26035	2800				0° 24'	0° 30'	±0,8	±1,6	0,6	0,8
6	15000	20000	78,1	0,88951	2000				0° 24'	0° 30'	±0,8	±1,6	0,6	0,8
7	30000	35000	128,4	1,77108	1500	-	-	-	-	-	-	-		

NOTES

- ⊗ **Code:** the 7th, 8th, 9th digits of the code indicate the Finished Bore diameter of an **EXTERNAL** half-hub in mm (000 = pilot bore).
- ⊗ **Code:** the 10th, 11th, 12th digits of the code indicate the Finished bore diameter of an **INTERNAL** half-hub in mm (000 = pilot bore).
- ⊗ **Technical characteristics:** the weights refer to the coupling with pilot bore; inertias refer to the coupling with maximum bore.

GD - gear coupling: introduction

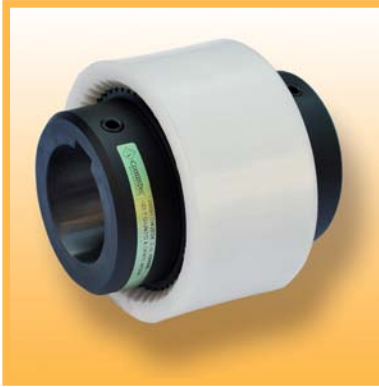

- Hubs made in steel fully turned with standard treatment of phosphating.
- Polyamide sleeve.
- Statically balanced.
- Maintenance and lubrication free.
- Compact and simple to be assembled.
- Vibrations dampening.

ON REQUEST

- Longer hubs possible.
- Version with sleeve in steel, circlip and seals.
- Version with sleeve directly integrated in one hub.
- Specific surface treatments possible.

The GD coupling is composed of two hubs in steel UNI EN 10083/98 fully turned, externally toothed with rounded profile and assembled only with a sleeve in polyamide stabilized resin, toothed internally.

Due to the tooth profile with which the hubs and the sleeve are connected, you can obtain a high contact surface also in presence of misalignments, in order to reduce the contact pressures, promoting a longer life.

The connection polyamide/steel assures a silent and reliable functioning, in absence of maintenance and lubrication.

This kind of coupling represents a reliable and economic kind of connection, for medium and big power industrial purposes.

DESCRIPTION OF THE SLEEVE

The standard sleeve is made in polyamide 6.6 stabilized resin, and its properties are the following:

- Resistant to all common lubricants and hydraulic fluids
- Suitable to operate in a continuous way on temperatures from -25°C up to 90°C and for short periods up to 125°C
- Optimum sliding properties
- High insulating capacities
- Optimum mechanical properties

DIMENSIONING

For pre-selection of the coupling's size you can use the generic formula indicated on page 5.

Having established the coupling's size to be used, it is possible to make other checks considering further parameters:

$$C_{nom} > C_{mot} \cdot f_T$$

Considering the starting torque:

$$C_{max} > C_{SM} \cdot \frac{J_{uti}}{J_{uti} + J_{mot}} \cdot K \cdot f_T \cdot f_A + C_{mot} \cdot f_T$$

$$C_{max} > C_{SU} \cdot \frac{J_{mot}}{J_{uti} + J_{mot}} \cdot K \cdot f_T \cdot f_A + C_{mot} \cdot f_T$$

Where

C_{nom} = nominal torque of the coupling [Nm]

C_{mot} = nominal torque motor side [Nm]

C_{max} = maximum torque of the coupling [Nm]

C_{SU} = starting torque user side [Nm]

C_{SM} = starting torque motor side [Nm]

f_A = starting frequency factor

f_T = thermic factor

J_{mot} = inertia motor side [Kgm²]

J_{uti} = inertia user side [Kgm²]

K = shock factor

Thermic factor (f_T)

1	-40 ÷ +60 °C
1,2	> +60 ÷ +70 °C
1,4	> +70 ÷ +80 °C
1,6	> +80 ÷ +90 °C
1,8	> +90 ÷ +100 °C

Shock factor (K)

1	slight impact
1,5	medium impact
1,8	strong impact

Starting frequency factor (f_A)

1	0 ÷ 100 starting each hour
1,2	> 100 ÷ 200 starting each hour
1,4	> 200 ÷ 400 starting each hour
1,6	> 400 ÷ 800 starting each hour

It is important to consider that misalignments, axial, angular and parallel, must be considered paired together, as inversely proportional (one reduces when the other increases). If all types of misalignments occur, it is necessary that the sum in percentage respect to the maximum value doesn't exceed 100%.

FITTING

Specific procedures to assemble this coupling are not required.

- 1) Achieve radial and axial alignment as precisely as possible to have the maximum absorption of possible misalignments and the maximal duration of the coupling.
- 2) Having pre-assembled the coupling, insert the external half-hub on one shaft. Check that the external parts of the two shafts don't exceed the relevant half-hub's surface (quote "N") and fix this one to the shaft with its relevant fixing system.
- 3) Insert the sleeve on the two half-hubs being careful to respect the distance of the same half-hubs, quote "P" on the catalogue.
- 4) Before starting transmission be sure that the sleeve can move axially free.

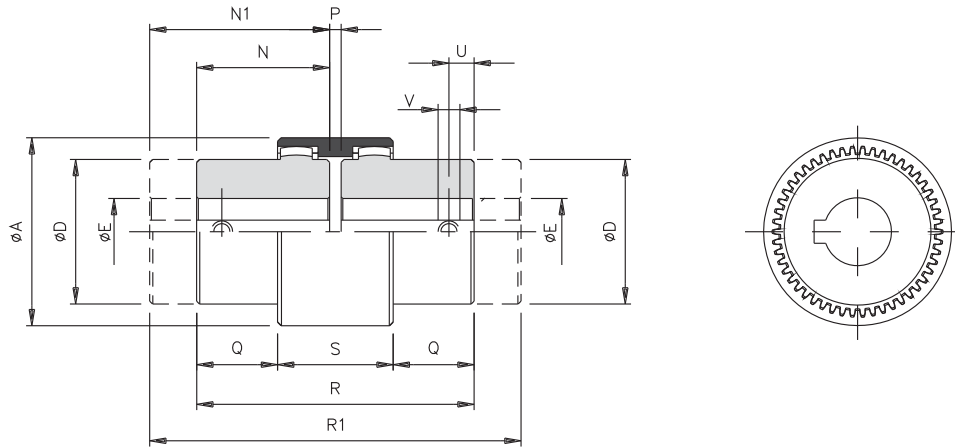

DIMENSIONS

Size	Codice	A	D	E H7		N	P	Q	R	S	U	V	Long hub - GD-2ML (on request)	
				pilot	max								N1	R1
1 (14)	200911000000	40	24	-	14	23	4	6,5	50	37	6	M5	40	84
2 (19)	200912000000	48	30	-	19	25	4	8,5	54	37	6	M5	40	84
3 (24)	200913000000	52	36	-	24	26	4	7,5	56	41	6	M5	50	104
4 (28)	200914000000	66	44	-	28	40	4	19	84	46	10	M8	60	124
5 (32)	200915000000	75	50	-	32	40	4	18	84	48	10	M8	60	124
6 (38)	200916000000	82	58	-	38	40	4	18	84	48	10	M8	80	164
7 (42)	200917000000	92	65	-	42	42	4	19	88	50	10	M8	110	224
8 (48)	200918000000	100	67	-	48	50	4	27	104	50	10	M8	110	224
9 (55)	200919000000	120	82	-	55	60	4	29,5	124	65	20	M10	110	224
10 (65)	200920000000	140	95	-	65	70	4	36	144	72	20	M10	140	284
11 (80)	200921000000	175	124	25	80	90	6	46,5	186	93	20	M10	-	-
12 (100)	200922000000	210	152	35	100	110	8	63	228	102	30	M12	-	-
13 (125)	200923000000	270	192	45	125	140	10	78	290	134	40	M16	-	-

TECHNICAL CHARACTERISTICS

Size	Torque [Nm]		Weight [Kg]			Inertia [Kgm ²]		Max speed [Rpm]	Operating temperature [°C]	Misalignments		
	Nom	Max	Std hub	Long hub	Sleeve	GD	GD-2ML			angular α [°]	axial X [mm]	radial K [mm]
1 (14)	11,5	23	0,10	0,13	0,022	0,000027	0,000034	14000	-25 ÷ +80	±1°	±1	±0,3
2 (19)	18,5	36,5	0,18	0,28	0,028	0,000050	0,000078	11800		±1°	±1	±0,3
3 (24)	23	46	0,23	0,42	0,037	0,000092	0,000173	10600		±1°	±1	±0,4
4 (28)	51,5	103,5	0,54	0,79	0,086	0,000311	0,000455	8500		±1°	±1	±0,4
5 (32)	69	138	0,66	0,97	0,104	0,000530	0,000795	7500		±1°	±1	±0,4
6 (38)	88	176	0,93	1,83	0,131	0,000959	0,001918	6700		±1°	±1	±0,4
7 (42)	110	220	1,10	2,76	0,187	0,001306	0,003420	6000		±1°	±1	±0,4
8 (48)	154	308	1,50	3,21	0,198	0,001815	0,003993	5600		±1°	±1	±0,4
9 (55)	285	570	2,63	5,12	0,357	0,004944	0,009064	4800		±1°	±1	±0,4
10 (65)	420	840	4,02	7,92	0,595	0,010634	0,021268	4000		±1°	±1	±0,6
11 (80)	700	1400	8,40	-	1,130	0,037055	-	3150		±1°	±1	±0,7
12 (100)	1200	2400	15,37	-	1,780	0,096122	-	3000		±1°	±1	±0,8
13 (125)	2500	5000	31,19	-	3,880	0,328750	-	2120		±1°	±1	±1,1

NOTES

- ⊗ **Code:** the 7th, 8th, 9th digits of the code indicate the Finished Bore diameter of a half-hub in mm (000 = pilot bore).
- ⊗ **Code:** the 10th, 11th, 12th digits of the code indicate the Finished bore diameter of the second half-hub in mm (000 = pilot bore).
- ⊗ **Technical characteristics:** the weights refer to the coupling with pilot bore; inertias refer to the coupling with maximum bore.

GF - highly flexible coupling: technical data



- Made in steel fully turned with standard treatment of phosphating.
- Simple manufacturing.
- High angular misalignments possible.
- Elastic element with an internal nylon weave for high reliability.
- Maintenance without moving the hubs axially possible.
- Finished bore and keyway with ISO H7 tolerance and low roughness.

ON REQUEST

- Different fixing systems on the hubs possible.
- Specific surface treatments possible.
- Connection to ComInTec TORQUE LIMITERS range possible.

The GF coupling, even if being built simply, assures a high elastic reliability which allows the recovery of high angular misalignments (up to 5°), absolutely reducing the drive irregularities.

It is composed of two hubs in steel UNI EN10083/98 fully turned and by an elastomeric central ring connected with screws and bolts in alternate way in respect to the two hubs.

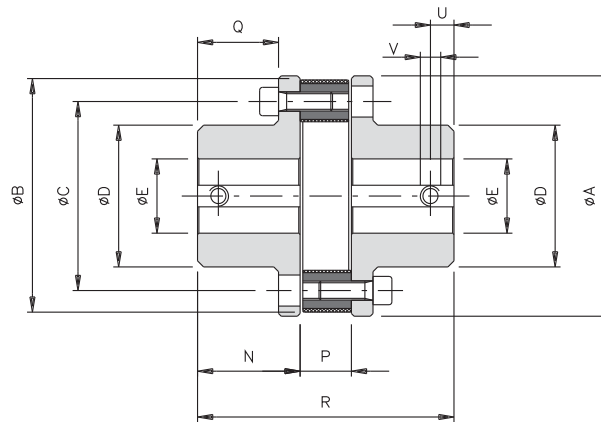

DIMENSIONS

Size	Code	A	B	C	D	E H7		N	P	Q	R	U	V	"W" model (on request)			
						pilot	max							Code	B	P	R
X 0	200820000000	98	100	78	48	10	28	45	17	34	107	8	M4	200822000000	100	22	112
X 1	200830000000	128	130	100	70	14	38	55	24	44	134	12	M6	200832000000	125	28	138
X 2	200840000000	162	165	125	90	19	48	72	29	56	173	12	M6	200842000000	155	34	178
X 3	200850000000	178	185	140	105	19	55	76	36	60	188	15	M8	200852000000	172	38	190
X 4	200860000000	198	205	160	125	28	65	84	44	68	212	15	M8	200862000000	193	42	210
X 5	200870000000	235	240	195	155	30	85	100	50	80	250	15	M8	200872000000	233	48	248

TECHNICAL CHARACTERISTICS

Size	"X" model					"W" model					Elastomeric element									
	Torque [Nm]		Weight [kg]	Inertia [kgm ²]	Max speed [rpm]	Misalignments			Size	Torque [Nm]		Weight [kg]	Inertia [kgm ²]	Max speed [rpm]	Misalignments			Hardness [Sh-A]	Operating temp. [°C]	Max temp. [°C]
	Nom	Max				angular α [°]	axial X [mm]	radial K [mm]		Nom	Max				angular α [°]	axial X [mm]	radial K [mm]			
X 0	75	225	3.4	0.00256	5000	3°	1.5	1	W 0	75	-	2.5	0.00256	5000	5°	3.5	1	70±5	-25 ÷ +70	+130
X 1	230	690	6.0	0.00826	4500	4°	2	1	W 1	150	-	4.6	0.00826	4500	5°	3.5	1			
X 2	470	1410	8.2	0.02654	3600	4°	2.5	1.5	W 2	250	-	8.0	0.02654	4000	5°	4.5	1.5			
X 3	750	2250	12.7	0.04268	3500	4°	3	1.5	W 3	450	-	12.4	0.04268	3600	5°	4.5	1.5			
X 4	1125	3375	16.9	0.07775	2800	4°	3	1.5	W 4	850	-	17.2	0.07775	3200	5°	4.5	1.5	60±5		
X 5	1700	5100	22.2	0.19375	2500	4°	3.5	1.5	W 5	1850	-	27.4	0.19375	2500	5°	5	1.5			

NOTES

- ⊗ **Code:** the 7th, 8th, 9th digits of the code indicate the Finished Bore diameter of a half-hub in mm (000 = pilot bore).
- ⊗ **Code:** the 10th, 11th, 12th digits of the code indicate the Finished bore diameter of the second half-hub in mm (000 = pilot bore).
- ⊗ **Technical characteristics:** the weights refer to the coupling with pilot bore; inertias refer to the coupling with maximum bore.

GFI - pin flexible coupling: technical data

- ⊙ Made in aluminium.
- ⊙ Simple manufacturing and assembly.
- ⊙ Low inertia.
- ⊙ Plug connection.
- ⊙ Suitable for low transmission power.
- ⊙ Finished bore and keyway with ISO H7 tolerance and low roughness.



ON REQUEST

- ⊙ Different fixing systems on the hubs possible.
- ⊙ Specific surface treatments possible.
- ⊙ Customized manufacturing for specific needs.

The GFI coupling is constructed with two aluminium hubs and one rubber elastic element hardness 79 Shore-A. The hubs connection is a simple plug in style to allow fast assembly and/or eventual maintenance.

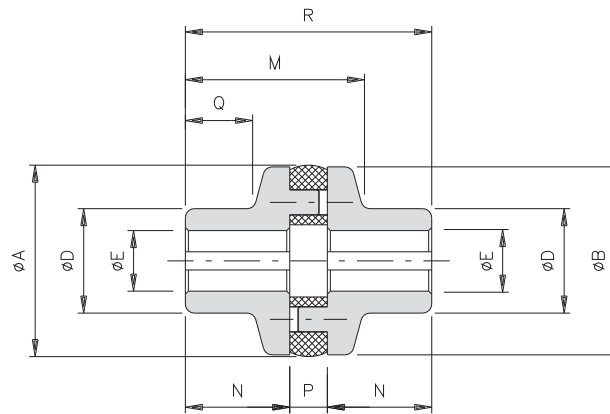

DIMENSIONS

Size	Code	A	B	D	E H7 max	M	N	P	Q	R
00.22	200836000000	22,5	22,5	12	6	22,5	12,5	6	8,5	31
00.28	200806000000	30	28	16	9	25	15	6	11	36
00.35	200816000000	35,5	35	20	11	30,5	18,5	7,5	14,5	45
00.45	200826000000	48	45	25	15	38	22,5	8,5	17	55

TECHNICAL CHARACTERISTICS

Size	Torque [Nm]		Weight [Kg]	Inertia [Kgm ²]	Max speed [Rpm]	Elastomeric element		Misalignments		
	Nom	Max				Tearing [N/mm ²]	Hardness [Sh-A]	angular α [°]	axial X [mm]	radial K [mm]
00.22	0,8	1,5	0,02	0,00007	18000	> 45	79 ±3	1°	0,1	0,1
00.28	1,0	2,2	0,04	0,00009	17000			1°	0,1	0,1
00.35	1,9	3,4	0,07	0,00018	16500			1°	0,1	0,1
00.45	3,5	6,3	0,13	0,00055	13000			1°	0,1	0,1

NOTES

- ⊗ **Code:** the 7th, 8th, 9th digits of the code indicate the Finished Bore diameter of a half-hub in mm (000 = pilot bore).
- ⊗ **Code:** the 10th, 11th, 12th digits of the code indicate the Finished bore diameter of the second half-hub in mm (000 = pilot bore).
- ⊗ **Technical characteristics:** the weights refer to the coupling with pilot bore; inertias refer to the coupling with maximum bore.

GC - chain coupling: technical data



- Made in steel fully turned with standard treatment of phosphating.
- Negligible power loss, absorbed by the coupling.
- Simple manufacturing.
- Hardening of hub teeth.
- Optimum quality / price ratio.
- Maintenance without moving the hubs axially.

ON REQUEST

- Different fixing systems on the hubs possible.
- Specific surface treatments possible.
- Connection to ComInTec TORQUE LIMITERS range possible.

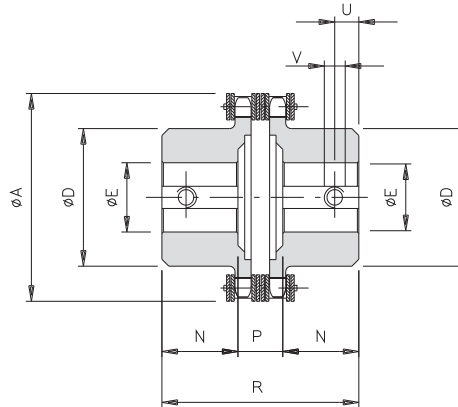

DIMENSIONS

Size	Code	A	D	E H7		N	P	R	U	V
				pilot	max					
01	200808000000	45	25	8	12	9	13	31	4	M3
00	200818000000	58	37	10	20	20	21	61	5	M3
0	200828000000	75	50	12	28	19	23,5	61,5	8	M4
1	200838000000	101	70	16	38	29	29	87	8	M4
2	200848000000	126	89	20	55	38	32	108	12	M6
3	200858000000	159	112	20	70	56	35,5	147,5	12	M6
4	200868000000	183	130	28	80	59	38,5	156,5	15	M8
5	200878000000	215	130	30	80	88	40	216	15	M8
6	200888000000	291	150	40	90	103	46	252	25	M10
7	200898000000	312	170	50	110	124	46	294	25	M10

TECHNICAL CHARACTERISTICS and NOTES

Size	Max Torque [Nm]	Pitch (double chain) ISO-R 606	Weight [Kg]	Inertia [Kg ^m ²]	Max speed [Rpm]	Misalignments		
						angular α [°]	axial X [mm]	radial K [mm]
01	140	3/8"x7/32" Z12	0,2	0,00002	6000	2°	1,50	0,20
00	190	3/8"x7/32" Z16	0,6	0,00009	5000	2°	1,50	0,20
0	600	3/8"x7/32" Z22	1,0	0,00030	3800	2°	1,50	0,20
1	700	1/2"x5/16" Z22	2,7	0,00148	2800	2°	2,40	0,25
2	1400	3/4"x7/16" Z18	5,4	0,00497	2200	2°	3,20	0,30
3	2500	1"x17,02 Z17	11,8	0,01817	1800	2°	4,50	0,35
4	3200	1"x17,02 Z20	16,9	0,03530	1500	2°	4,80	0,40
5	4000	1"x17,02 Z24	19,5	0,05333	1300	2°	4,80	0,40
6	7000	1"1/4x3/4" Z26	42,5	0,19027	1000	2°	6,30	0,50
7	8000	1"1/4x3/4" Z28	58,6	0,28643	900	2°	6,30	0,50

NOTES

- ⊗ **Code:** the 7th, 8th, 9th digits of the code indicate the Finished Bore diameter of a half-hub in mm (000 = pilot bore).
- ⊗ **Code:** the 10th, 11th, 12th digits of the code indicate the Finished bore diameter of the second half-hub in mm (000 = pilot bore).
- ⊗ **Technical characteristics:** the weights refer to the coupling with pilot bore; inertias refer to the coupling with maximum bore.

LABEL

ComInTec, as identification batch for each group, uses a plastic label on all the elements assisting traceability of the item and of the production.

This is also necessary for eventual spare parts, repeat orders, or to ask for information regarding a specific product.

Following is an explanation of the label:

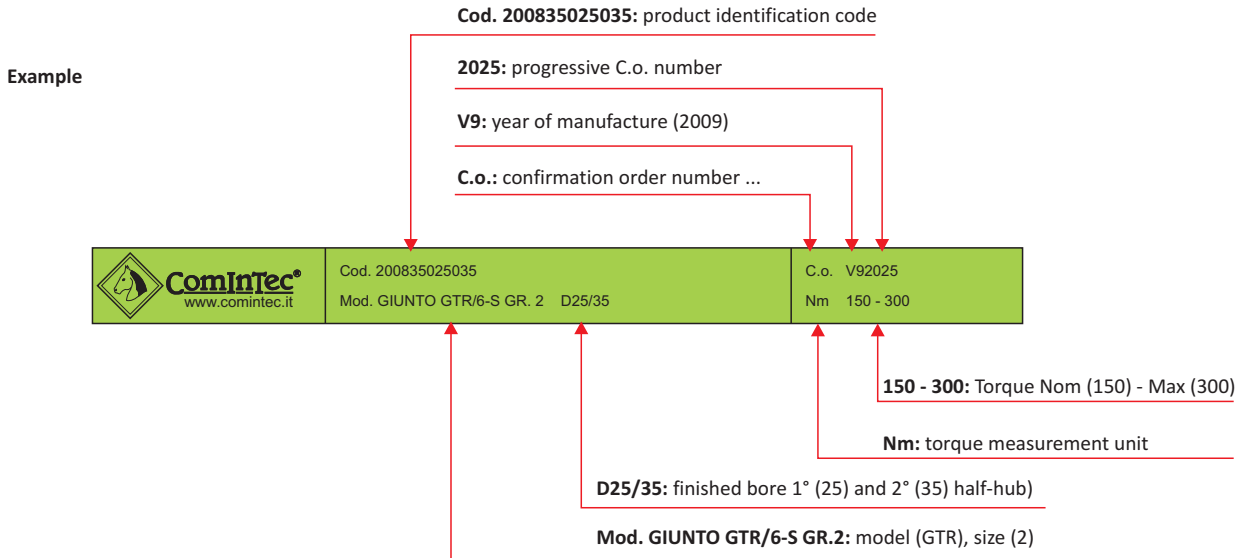

MARKING

Example:

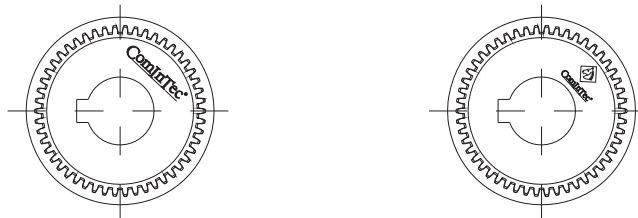

ComInTec® CERTIFICATIONS

SINCERT



- Certified company since February 1996 according to **UNI EN ISO 9008:2008**



- Maximum attention to market requests for conformity with 94/9/CE (ATEX) for use in potentially explosive environments.



- Company and production **"Made in Italy"**.

RoHS
2002/95/CE

- Internal and external environment protection complying with directive 2002/95/CE (RoHS), that forbids the use of harmful substances during the production progress or in the end product, and complying with D.Lgs. 626/94 for security and health at work.



- Continuous product research and development, some of them with Italian and European patent



- European Power Transmission Distributors Association (EPTDA). The largest organisation of distributors and manufacturers of power transmission and motion control products in Europe.

PROJECT REQUEST



Your needs are our priorities.

If you need help for a product design, contact ComInTec experts for assistance and advice. It helps to fill in this form. Your request will be handled in the shortest time possible.

General information:

- Company name: -----
- City / State: -----
- Name / Surname: -----
- Title: -----
- Phone: -----
- E-mail / website: -----
- Quantity: -----
- Planned yearly quantities: -----
- Target price: -----

Use:

- OEM name / website: _____
- Application field / type of machine: _____
- Where it is applied: _____
- Model currently used: _____
- Nominal torque (Nm): _____
- Speed (Rpm): _____
- Workplace:
 - Clean
 - Dusty
 - Humid / Wet
 - Other_____
- Type of coupling: _____
- Driving shaft diameter (mm): _____
- Driving shaft connection type:
 - Keyway
 - Locking assembly
 - Other _____





Driven shaft diameter (mm): _____
 Driven shaft connection type:
 Keyway
 Locking assembly
 Other _____
 Notes: _____

IF REQUIRED WITH ComInTec TORQUE LIMITER

What it protects: _____
 Re-engagement position:
 Equidistant
 360°
 Not important
 Other _____
 Electric signal of overload required:
 Yes
 No
 Note: _____

Signature

PLEASE ALSO SEND, IF AVAILABLE, A DRAWING OR PHOTOGRAPH. IT CAN ASSIST US ENORMOUSLY IN HELPING TO FULLY UNDERSTAND YOUR APPLICATION.

Send to tecnico@comintec.it or by fax +39 051 782256 (Att. Technical Department)



PRODUCTION PROGRAMME



TORQUE LIMITERS



CLUTCHES



ELASTOMERIC COUPLINGS - RIGID COUPLINGS



LOCKING RINGS



VARIABLE SPEED PULLEYS - MOTOR SLIDE BASES



ComInTec[®]