



I N T R O D U C I N G

Spring-Set Brake Module

For Holding Applications



Warner Electric presents the latest addition to the Electro Module product line

The Spring-Set Brake Module is a NEMA C-face compatible unit designed to perform holding as well as occasional emergency stopping functions, making it particularly well-suited for motor brake applications. Because it is designed to be mounted on the front of a motor, it is an excellent choice for retrofitting an existing motor, or for use on custom designed machinery.

Applications include holding railroad crossing arms, basketball backboards, robotic arms, and assemblies on vertical ball screws.



An Altra Industrial Motion Company

For technical assistance call 800-825-9050

Spring-Set Brake Module

Specifications and Dimensions

Packaged Spring-Set Brake Module Features

- NEMA C-face compatible mounting
- Performs holding functions with occasional e-stops
- Completely assembled and preburnished at the factory
- Easy to install
- No adjustment required
- High torque, lead-free and asbestos-free friction material
- UL and CUL listed

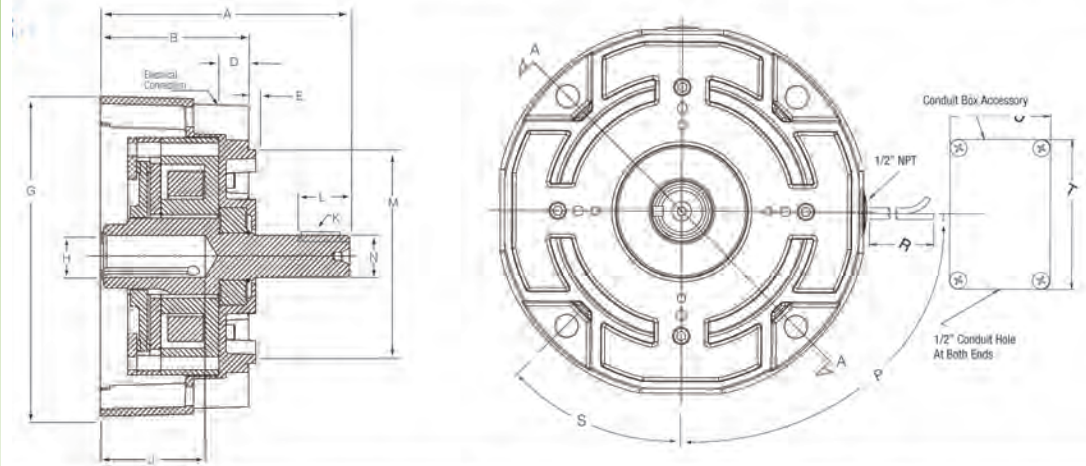

Model	NEMA Frame Size	Holding Torque (ft-lbs)	Max RPM	Unit Weight (lbs)	Unit Inertia (lb-in ²)	Voltage (DC)	Power (Watts)	Current (Amperes)	Resistance (Ohms)	Part Number
EM-50/ERS-42	56C/48Y	7.0	3600	6.4	.295	24	23.3	0.973	24.67	5370-170-201
						90	21.5	0.239	376.2	5370-170-203
EM-50/ERS-49	56C/48Y	15.0	3600	8.2	.673	24	27.2	1.13	21.2	5370-170-206
						90	25.7	0.285	315.1	5370-170-207
EM-180/ERS-57	182C/143TC 184C/145TC	34.0	3600	10.4	.955	24	36.2	1.507	15.90	5370-170-211
						90	35.2	0.391	230.1	5370-170-212
EM-210/ERS-68	213C/182TC 215C/184TC	100.0	2000	24.7	3.842	24	54.9	2.286	10.50	5371-170-042
						90	51.9	0.577	155.9	5371-170-043

Model	A	B	D	E Max	Not Shown Bolts (4)	G	H		J	K	L	M	N	P	R	S	T	U
							Dia	Key										
EM-50 ERS-42	5.197	3.125	1.150	.156	(4) 3/8-16 UNC on 5.875 Dia	6.750	.625	3/16x3/16	2.207	3/16x3/16	1.437	4.500 Pilot Dia	.625 Dia	90°	36	45°	3.25	2.188
EM-50 ERS-49	5.197	3.125	1.150	.156	(4) 3/8-16 UNC on 5.875 Dia	6.750	.625	3/16x3/16	2.207	3/16x3/16	1.437	4.500 Pilot Dia	.625 Dia	90°	36	45°	3.25	2.188
EM-180 ERS-57	5.257	3.125	1.150	.156	(4) 3/8-16 UNC on 5.875 Dia	6.750	.875	3/16x3/16	2.211	3/16x3/16	1.437	4.500 Pilot Dia	.875 Dia	90°	36	45°	3.25	2.188
EM-210 ERS-68	7.539	4.609	1.507	.315	(4) 1/2-13 UNC on 7.250 Dia	9.344	1.125	1/4x1/4	3.002	1/4x1/4	2.125	8.500 Pilot Dia	1.125 Dia	25°	36	45°	3.25	2.188

All dimensions are nominal unless otherwise noted.



www.warnerelectric.com

31 Industrial Park Road
New Hartford, CT 06057 - USA
815-389-3771
Fax: 815-389-2582