

# Permanent Magnet and Magnetic Particle Clutches and Brakes



 **Warner**<sup>®</sup>  
Electric

An Altra Industrial Motion Company

# Precision Tork

## Permanent Magnet Clutches and Brakes



Precision Tork units provide constant torque independent of slip speed. They offer excellent overload and jam protection for all drive train components and also provide soft starts with zero slip when a preset torque is reached. Precision Tork permanent magnet clutches and brakes do not require maintenance and provide extremely long life.

## Magnetic Particle Clutches and Brakes

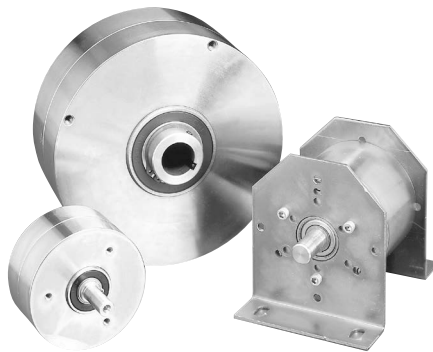

Warner Electric Precision Tork magnetic particle clutches and brakes are unique because of the wide operating torque range available. Torque to current is almost linear and can be controlled very accurately. The unique features of the magnetic particle clutches and brakes make them ideal for tension control, load simulation, cycling/indexing, and soft starts and stops.

## Magnetic Capping Headsets

Warner Electric Precision Tork Magnetic Capping Headsets are 100% interchangeable with many major OEM headsets. Warner Electric headsets feature constant Smooth Torque Technology. They are easy to install and maintain with little adjustment required. The Precision Tork headset has a unique visual scale for setting both application torque & the top load spring.

## Permanent Magnet Clutches and Brakes

Features and Benefits .....	1
Special Applications.....	1
Applications.....	2
Specifications.....	3
Mounting Arrangements.....	3
Stainless Steel Designs .....	4
Hollow Bore Units.....	6
Solid Shaft Units.....	7
Mounting Bracket.....	7
Heat Dissipation Charts .....	8
Torque Setting Charts .....	9
Stub Shaft Adapters.....	10
How to Order.....	10

## Magnetic Particle Clutches and Brakes

Features and Benefits .....	12
Design and Operation .....	13
Selection.....	14
Applications.....	16
Clutches - Dimensions and Specifications .....	19
Mounting Bracket.....	19
Brakes – Dimensions and Specifications .....	20
Controls.....	21

## Magnetic Capping Headsets

Replacements .....	22
Features and Benefits .....	23
Models Available .....	23
Dairy Capchucks .....	24
Chucks and Knives.....	25



# Permanent Magnet Clutch and Brakes

## Fast, precise torque adjustment!

### Precision Tork™ clutches and brakes

Precision Tork units provide constant torque independent of slip speed. They offer excellent overload and jam protection for all drive train components and also provide soft starts with zero slip when a preset torque is reached. Precision Tork permanent magnet clutches and brakes do not require maintenance and provide extremely long life.

## Features and Benefits

### Fast, precise torque adjustment

- Torque is set with a large knurled adjustment ring.
- Infinite adjustability between minimum and maximum settings. This allows units to be fine tuned to your unique requirement.
- Easy to read graduations.

### Torque is constant with respect to speed

- By using the Precision Tork unit, you can solve almost any torque control problem.
- Torque is extremely consistent and smooth at low, as well as high speeds.

### No external control or power source

- Simple to install
- Nothing to monitor
- Unaffected by power interruption or power fluctuation
- Safe to use

### Dependable performance

- Smallest possible transition from static to dynamic torque. Virtually eliminates the “stick-slip” phenomenon associated with friction devices.
- Long life. The only wearing parts are the ball bearings.
- Extremely accurate. Precision Tork units out-perform all other devices at low RPM.

### Versatile mounting: Easy to retrofit

- Clutches are available with hollow bores for mounting on motor shafts or jack shafts.
- Bolt circles allow for fixed mounting, adding a pulley, or stub shaft adapters.
- Brakes are available with solid shaft outputs.

### Distributor item

- Off the shelf availability.
- Interchangeable with competitors' products.

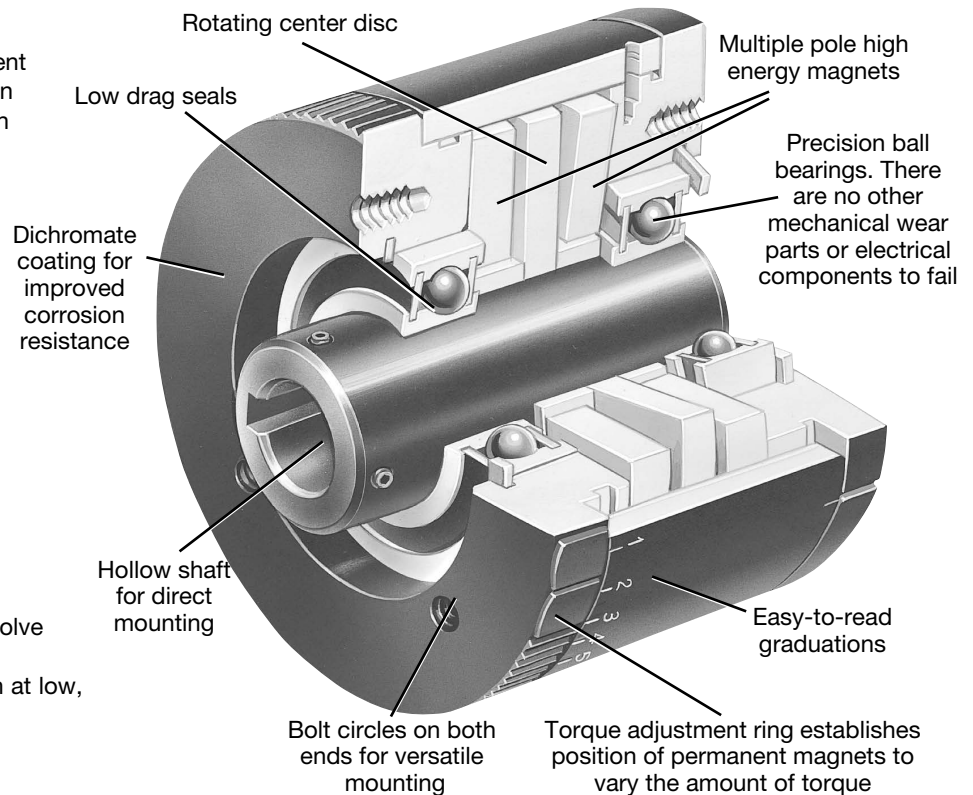

## Specials are our business. . .

- Special shaft bores and keyways
- Shaft extensions
- System retrofits
- Metric bores and keyways
- Stainless steel construction
- Fixed torque units

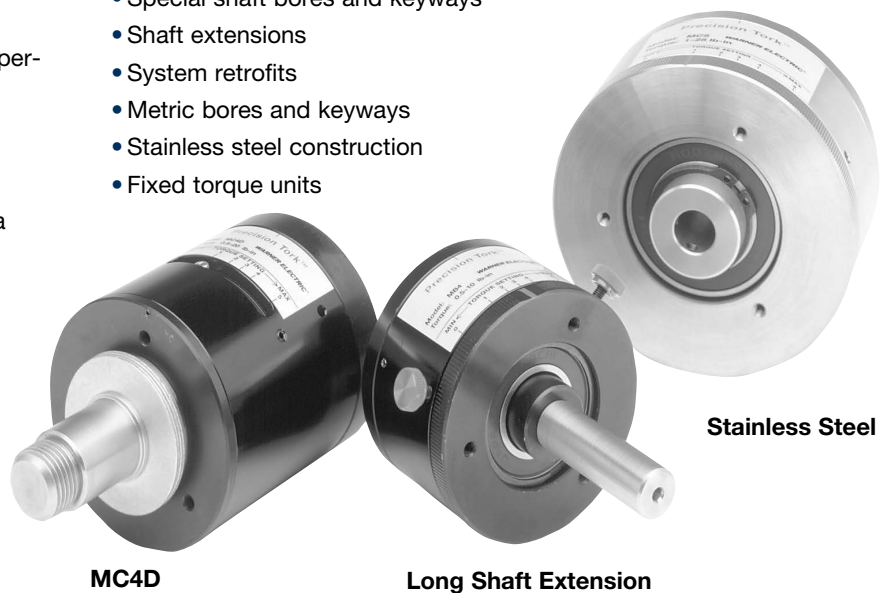



# Applications

## Unwind tension control

Brake mounted on shaft of unwind spool or bobbin.

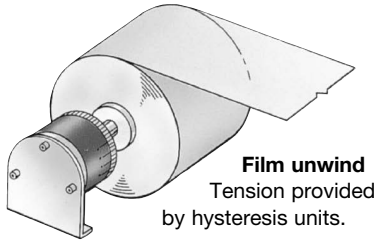

**Film unwind**  
Tension provided by hysteresis units.

### Information required:

Full roll diameter (in.) = 6 in.  
Core diameter (in.) = 4 in.  
Average tension (lbs.) = 4 lbs.  
Velocity (feet per min.) = 100 fpm

### How to size:

$$\text{Average radius (in.)} = \frac{\text{Full roll dia. (in.)} + \text{Core dia. (in.)}}{4}$$

$$= \frac{6 + 4}{4} = 2.5 \text{ in.}$$

$$\text{Torque (lb.in.)} = \text{Avg. tension (lbs.)} \times \text{Avg. radius (in.)}$$

$$= 4 \times 2.5 = 10 \text{ lb.in.}$$

Check tension range:

$$\text{Max. tension} = \text{Torque (lb.in.)} \times \frac{2}{\text{Core dia. (in.)}} = 10 \times \frac{2}{4} = 5 \text{ lbs.}$$

$$\text{Min. tension} = \text{Torque (lb.in.)} \times \frac{2}{\text{Full roll dia. (in.)}} = 10 \times \frac{2}{6} = 3.3 \text{ lbs.}$$

$$\text{Slip watts} = \frac{\text{Max. tension (lbs.)} \times \text{velocity (fpm)}}{44.2}$$

$$= 11.3 \text{ watts}$$

**Select Model MC4**

## Cycling

**Bottle capping**  
Constant torque provided by a hysteresis clutch.

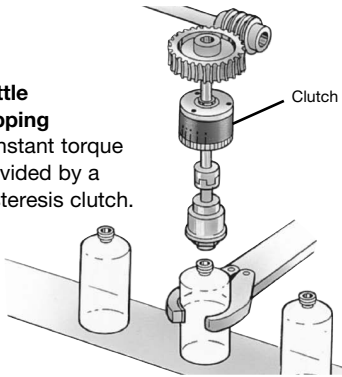

### Information required:

Slip RPM = 500 RPM  
Torque = 8 lb.in.  
% slip time of total cycle time = 25%

### How to size:

$$\text{*Watts} = .0118 \times \text{torque (lb.in.)} \times \text{slip RPM} \times \% \text{ slip time}$$

$$= .0118 \times 8 \times 500 \times .25 = 11.8 \text{ watts}$$

Select an MC4 from the specification chart.

\*Note: Consult factory if peak slip watts are extremely high or if duration of slip period is in excess of 1 minute.

## Nip roll or pulley tension control

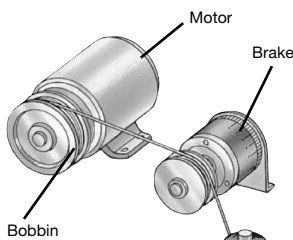

**Coil winding**  
Constant tension provided by hysteresis unit.

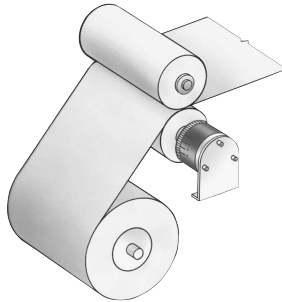

**Film tensioning**  
Constant tensioning supplied by hysteresis unit.

### Information required:

Pulley or nip roll diameter = 4 in. Tension = 6 lbs. Velocity = 100 fpm

### How to size:

$$\text{Torque (lb.in.)} = \text{Tension (lbs.)} \times \frac{\text{Dia. (in.)}}{2} = 6 \times \frac{4}{2} = 12 \text{ lb.in.}$$

$$\text{Slip watts} = \frac{\text{Tension (lbs.)} \times \text{velocity (fpm)}}{44.2} = \frac{6 \times 100}{44.2} = 13.5 \text{ watts}$$

**Select Model MC5**

## Overload protection/Torque limiting/Soft start

Motor horsepower method

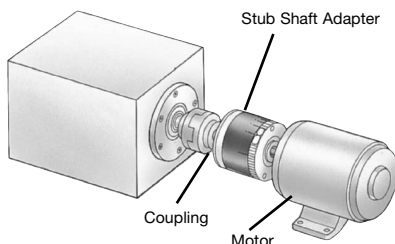

**Torque limiting**  
Hysteresis clutch provides overload protection.

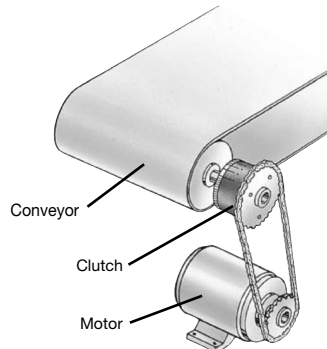

**Material handling**  
Hysteresis clutch can provide overload protection and soft start.

### Information required:

Motor HP = 1/2 HP  
Motor RPM = 1750 RPM

### How to size:

$$\text{Torque (lb.in.)} = \frac{\text{HP} \times 63000}{\text{RPM}}$$

$$= \frac{1/2 \times 63000}{1750} = 18 \text{ lb.in.}$$

Select an MC5 from the specification chart.

# Standard Clutches and Brakes

## Specifications



### Hollow Bore Configurations

Model Size	Torque	Heat Dissipation (watts)	Inertia (lbs. sq. in.)	Bending Moment (lb. in.)	Max. RPM	Weight (lbs.)	Bore Range/Shaft Dia. (in.)
<b>MC1.5</b>	1–13 oz. in.	10	0.02	5	3600	10.5 oz.	1/4
<b>MC2</b>	0.5–22 oz. in.	10	0.02	5	3600	11 oz.	1/4
<b>MC2.5</b>	0.5–5.5 lb. in.	15	0.11	10	1800	1.5	3/8, 1/2
<b>MC3</b>	0.5–6 lb. in.	18	0.14	10	1800	2.5	5/16, 3/8
<b>MC4</b>	0.7–10 lb. in.	22	0.32	10	1800	3.5	3/8, 1/2, 5/8
<b>MC5</b>	1–30 lb. in.	72	1.72	25	1800	9.5	3/8, 1/2, 5/8, 3/4, 7/8, 1
<b>MC5.5</b>	1–50 lb. in.	110	2.74	25	1800	12	3/8, 1/2, 5/8, 3/4, 7/8, 1
<b>MC6</b>	1–68 lb. in.	150	4.28	25	1800	12	3/8, 1/2, 5/8, 3/4, 7/8, 1
<b>MC6D</b>	6–136 lb. in.	300	8.52	25	1800	24	1/2, 5/8, 3/4, 7/8, 1
<b>MC9</b>	15–300 lb. in.	345	65.74	50	1200	48	5/8, 3/4, 7/8, 1, 1-1/8, 1-1/4



### Solid Shaft Configurations

<b>MB1</b>	0-1.1 oz. in.	3	0.001	1	3600	2.5 oz.	3/16
<b>MB1.5</b>	1–13 oz. in.	10	0.02	5	3600	11 oz.	1/4
<b>MB2</b>	.5-22 oz. in.	10	0.02	5	3600	11.5 oz.	1/4, 3/8
<b>MB2.5</b>	.5–5.5 lb. in.	15	0.11	10	1800	2.5	3/8, 1/2
<b>MB3</b>	0.5–6 lb. in.	18	0.14	10	1800	2	3/8
<b>MB4</b>	0.7–10 lb. in.	22	0.33	10	1800	3.5	1/2, 5/8
<b>MB5</b>	1–30 lb. in.	72	1.76	25	1800	10	1
<b>MB5.5</b>	1–50 lb. in.	110	2.79	25	1800	12.5	1
<b>MB6</b>	1–68 lb. in.	150	4.33	25	1800	12	1
<b>MB6D</b>	6–136 lb. in.	300	8.68	25	1800	26	7/8
<b>MB9</b>	15–300 lb. in.	345	66.09	50	1200	48	1

## Typical Mounting Arrangements

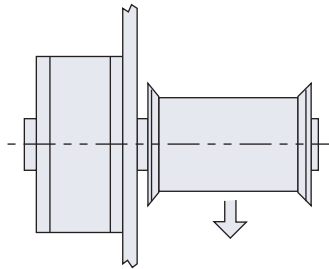

### Brake:

Typical setup for tensioning wire, film and fibers.

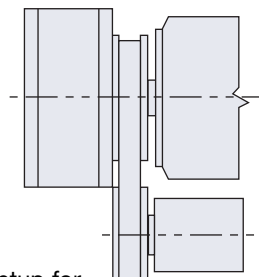

### Clutch:

Typical setup for material handling, soft starts and torque limiting.

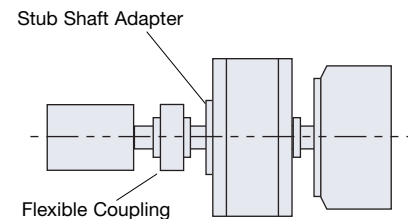

### Clutch Coupling:

Typical setup for torque limiting protection used for labeling, capping and printing applications.

# Stainless Steel Clutches and Brakes

## Specifications



### Hollow Bore Configurations

Model Size	Torque	Heat Dissipation (watts)	Inertia (lbs. sq. in.)	Bending Moment (lb. in.)	Max. RPM	Weight (lbs.)	Bore Range/Shaft Dia. (in.)
<b>MC1.5</b>	1–13 oz. in.	10	0.02	5	3600	10.5 oz.	1/4
<b>MC2</b>	0.5–22 oz. in.	10	0.02	5	3600	11 oz.	1/4
<b>MC2.5</b>	0.5–5.5 lb. in.	15	0.11	10	1800	1.5	3/8, 1/2
<b>MC3</b>	0.5–6 lb. in.	18	0.14	10	1800	2.5	5/16, 3/8
<b>MC4</b>	0.7–10 lb. in.	22	0.32	10	1800	3.5	3/8, 1/2, 5/8
<b>MC5</b>	1–30 lb. in.	72	1.72	25	1800	9.5	3/8, 1/2, 5/8, 3/4, 7/8, 1
<b>MC5.5</b>	1–50 lb. in.	110	2.74	25	1800	12	3/8, 1/2, 5/8, 3/4, 7/8, 1

\* Size 6D NS 9 are not currently available as stainless steel products.



### Solid Shaft Configurations

<b>MB1</b>	0–1.1 oz. in.	3	0.001	1	3600	2.5 oz.	3/16
<b>MB1.5</b>	1–13 oz. in.	10	0.02	5	3600	11 oz.	1/4
<b>MB2</b>	.5–22 oz. in.	10	0.02	5	3600	11.5 oz.	1/4, 3/8
<b>MB2.5</b>	.5–5.5 lb. in.	15	0.11	10	1800	2.5	3/8, 1/2
<b>MB3</b>	0.5–6 lb. in.	18	0.14	10	1800	2	3/8
<b>MB4</b>	0.7–10 lb. in.	22	0.33	10	1800	3.5	1/2, 5/8
<b>MB5</b>	1–30 lb. in.	72	1.76	25	1800	10	1
<b>MB5.5</b>	1–50 lb. in.	110	2.79	25	1800	12.5	1
<b>MB6</b>	1–68 lb. in.	150	4.33	25	1800	12	1
<b>MC6</b>	1–68 lb. in.	150	4.28	25	1800	12	3/8, 1/2, 5/8, 3/4, 7/8, 1

## Stainless steel clutches and brakes for harsh environments

Caustic washdown solutions can cause corrosion and eventual failure in food processing applications such as meat and poultry. That's why we have introduced a new line of all stainless steel clutches and brakes. These units, featuring 400 series stainless steel bearings, are robust enough to handle the most hostile washdown environments and tough enough to perform 24/7.



# Hollow Bore Configurations

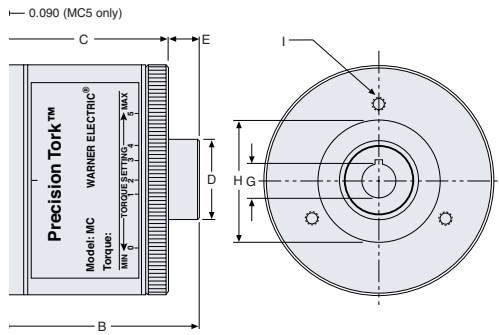

**Drawing A**

\*Set screw adjustment

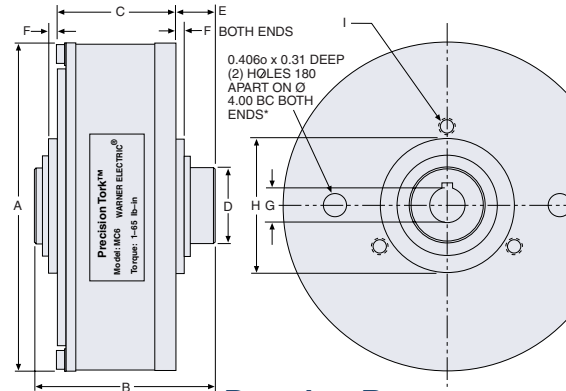

**Drawing B**

\*Spanner wrench adjustment

Model	Drawing	A	B	C	D	E	F
MC1.5	A	1.85	1.62	1.38	0.375	0.24	–
MC2	A	1.85	1.62	1.35	0.375	0.27	–
MC2.5	A	2.31	2.52	2.23	0.79	0.29	–
MC3	A	2.74	2.22	1.98	0.590	0.24	–
MC4	A	3.23	2.27	2.01	0.98	0.26	–
MC5	A	4.65	3.18	2.64	1.372	0.45	–
MC5.5	A	5.29	3.21	2.64	1.372	0.57	–
MC6	B	6.05	3.18	2.02	1.372	0.76	0.18
MC6D	B	7.15	5.03	4.06	1.378	0.59	0.29
MC9	B	9.40	4.18	3.49	1.77	0.56	0.13

## Bore & Keyseat Sizes

Model	Keyseat	Lockdown Method	G (Bore)	H (Pilot-Both Ends)	I (Both Ends)
MC1.5	None	3/32 Roll Pin	1/4	0.877–0.876 x 0.08 dp	3) 6-32 x 5/16 dp 1.25 B.C.
MC2	None	3/32 Roll Pin	1/4	0.877–0.876 x 0.08 dp	3) 6-32 x 5/16 dp 1.25 B.C.
MC2.5	None	2) Set Screws	3/8	1.655–1.653 x 0.10 dp	3) 10-32 x 7/16 dp 1.875 B.C.
	1/8 Key	2) Set Screws	1/2		
MC3	None	2) Set Screws	5/16	1.383/1.381 x .120 dp	3) 10-32 x 7/16 dp 1.875 B.C.
	None	2) Set Screws	3/8		
MC4	None	2) Set Screws	3/8	1.854–1.852 x 0.08 dp	3) 10-32 x 7/16 dp 2.375 B.C.
	1/8 Key	2) Set Screws	1/2		
	3/16 Key	2) Set Screws	5/8		
MC5	None	2) Set Screws	3/8	2.441/2.440 x .10 dp	3) 10-32 x 1/2 dp 3.00 B.C.
	1/8 Key	2) Set Screws	1/2		
	3/16 Key	2) Set Screws	5/8		
	3/16 Key	2) Set Screws	3/4		
	3/16 Key	2) Set Screws	7/8		
MC5.5	1/4 Shallow	2) Set Screws	1	2.441/2.440 x .26 dp	3) 10-32 x 1/2 dp 3.00 B.C. and 3) 5/16–18 x 0.62 dp 3.50 B.C.
	None	2) Set Screws	3/8		
	1/8 Key	2) Set Screws	1/2		
	3/16 Key	2) Set Screws	5/8		
	3/16 Key	2) Set Screws	3/4		
MC6	3/16 Key	2) Set Screws	7/8	2.441/2.440	3) 1/4-20 x 5/16 dp 2.875 B.C.
	1/4 Shallow	2) Set Screws	1		
	None	2) Set Screws	3/8		
	1/8 Key	2) Set Screws	1/2		
	3/16 Key	2) Set Screws	5/8		
MC6D	3/16 Key	2) Set Screws	3/4	3.250/3.248	3) 5/16-18 x 1/2 dp 4.00 B.C.
	3/16 Key	2) Set Screws	7/8		
	1/4 Shallow	2) Set Screws	1		
	3/16 Key	2) Set Screws	5/8		
MC9	3/16 Key	2) Set Screws	3/4	3.250/3.248	4) 5/16–18 x 0.50 dp 5.875 B.C. and 3) 5/16-18 x 1/2 dp 4.25 B.C.
	3/16 Key	2) Set Screws	7/8		
	1/4 Key	2) Set Screws	1		
	1/4 Key	2) Set Screws	1-1/8		
	1/4 Key	2) Set Screws	1-1/4		



# Solid Shaft Configurations

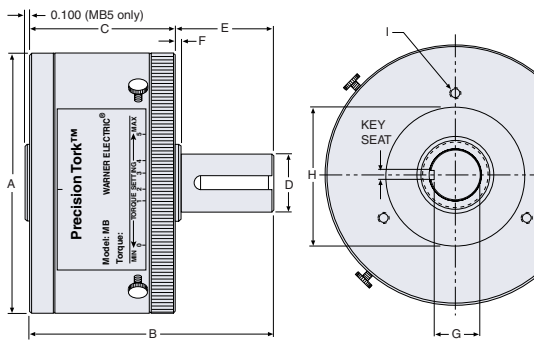

**Drawing C**

\*Thumb screw adjustment

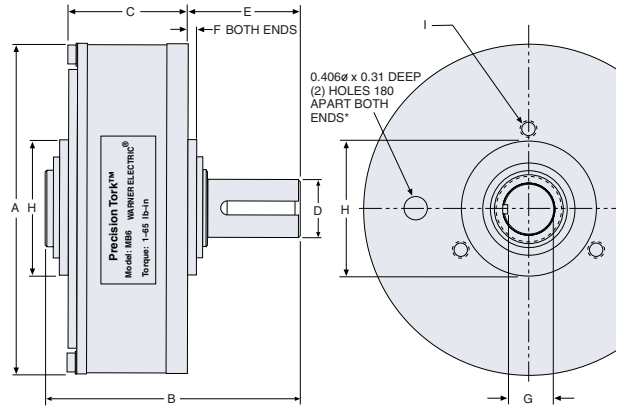

**Drawing D**

\*Spanner wrench adjustment

Model	Drawing	A	B	C	D (Shaft)	E	F	G	KEY SEAT	H (Pilot-Both Ends)	I (Both Ends)
MB1	C	0.99	1.37	0.86	3/16	0.51	-	0.170 Flat	-	0.300/0.302 x 0.12 dp	3) 4-40 x 1/4 dp 0.610 B.C.
MB1.5	C	1.85	2.36	1.38	1/4	.98	-	0.230 Flat	-	0.876/0.877 x 0.08 dp	3) 6-32 x 5/16 dp 1.250 B.C.
MB2	C	1.85	2.36	1.35	1/4	1.01	-	0.230 Flat	-	0.876/0.877 x 0.08 dp	3) 6-32 x 5/16 dp 1.250 B.C.
	C	1.85	2.36	1.35	3/8	1.01	-	0.355 Flat	-	0.876/0.877 x 0.08 dp	3) 6-32 x 5/16 dp 1.250 B.C.
MB2.5	C	2.31	3.35	2.23	3/8	1.12	-	0.355 Flat	-	1.653/1.655 x 0.10 dp	3) 10-32 x 7/16 dp 1.875 B.C.
	C	2.31	3.35	2.23	1/2	1.12	-	0.430/0.414	0.125	1.653/1.655 x 0.10 dp	3) 10-32 x 7/16 dp 1.875 B.C.
MB3	C	2.74	3.02	1.98	3/8	1.04	0.04	0.355 Flat	-	1.383/1.381 x 0.12 dp	3) 10-32 x 7/16 dp 1.875 B.C.
MB4	C	3.23	2.98	2.01	1/2	0.97	0.09	0.430/0.414	0.125	1.852/1.854 x 0.08dp	3) 10-32 x 7/16 dp 2.375 B.C.
	C	3.23	2.98	2.01	5/8	0.97	0.09	0.518/0.502	0.188	1.852/1.854 x 0.08dp	3) 10-32 x 7/16 dp 2.375 B.C.
MB5	C	4.65	4.48	2.64	1	1.75	0.12	0.860/0.844	0.250	2.441/2.440 x 0.100 dp	3) 10-32 x 1/2 dp 3.000 B.C.
MB5.5	C	5.29	4.53	2.65	1	1.88	0.25	0.860/0.844	0.250	2.441/2.440 x 0.26 dp	3)10-32 x 1/2 dp 3.000 B.C.
											and 3) 5/16-18 x 0.62 dp 3.500 B.C.
MB6	D	6.05	4.48	2.02	1	2.06	0.18	0.860/0.844	0.250	2.441/2.440	3) 1/4-20 x 5/16 dp 2.875 B.C.
MB6D	D	6.95	6.23	4.06	7/8	1.81	0.24	0.771/0.755	0.188	3.250/3.248	3) 5/16-18 x 1/2 dp 4.000 B.C.
MB9	D	9.40	5.39	3.49	1	1.77	0.13	0.860/0.844	0.250	3.250/3.248	4) 5/16-18 x 1/2 dp 5.875 B.C.
											and 3) 5/16-18 x 1/2 dp 4.250 B.C.

## Optional Mounting Bracket

Note: Mount bracket to fixed end cap – side opposite knurled adjustment ring.

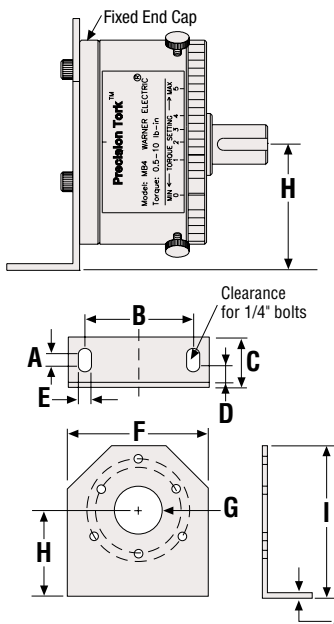

Model	Fits Size	A	B	C	D	E	F	G	H	I
MPB-2B (MPB-2BM)	MB1.5, 2	0.270	1.750	1.155	0.390	0.280	2.500	0.755	1.500	3.000
	MC1.5, 2	(6.9)	(44.5)	(29.3)	(9.9)	(7.1)	(63.5)	(19.2)	(38.1)	(76.2)
MPB-15B (MPB-15BM)	MB2.5/MC2.5, 3, 4	0.270	2.500	1.155	0.390	0.280	3.500	1.130	2.000	4.000
	MB4/MC4, 3, 4	(6.9)	(63.5)	(29.3)	(9.9)	(7.1)	(88.9)	(28.7)	(50.8)	(101.6)
MPB-70B (MPB-70BM)	MB5/	0.270	4.875	1.155	0.390	0.280	6.000	1.630	3.500	6.000
	MC5	(6.9)	(123.8)	(29.3)	(9.9)	(7.1)	(152.4)	(41.4)	(88.9)	(152.4)
MPB-120B (MPB-120BM)	MB5.5	0.270	4.875	1.155	0.390	0.280	6.000	1.630	3.500	6.250
	MC5.5	(6.9)	(123.8)	(29.3)	(9.9)	(7.1)	(152.4)	(41.4)	(88.9)	(158.8)
MPB-240B (MPB-240BM)	MB6	0.270	4.875	1.155	0.390	0.280	6.500	2.445	4.000	7.500
	MC6	(6.9)	(123.8)	(29.3)	(9.9)	(7.1)	(165.1)	(62.1)	(101.6)	(190.5)

All dimensions are nominal unless otherwise noted. ( ) denotes (mm)

# Heat Dissipation Charts

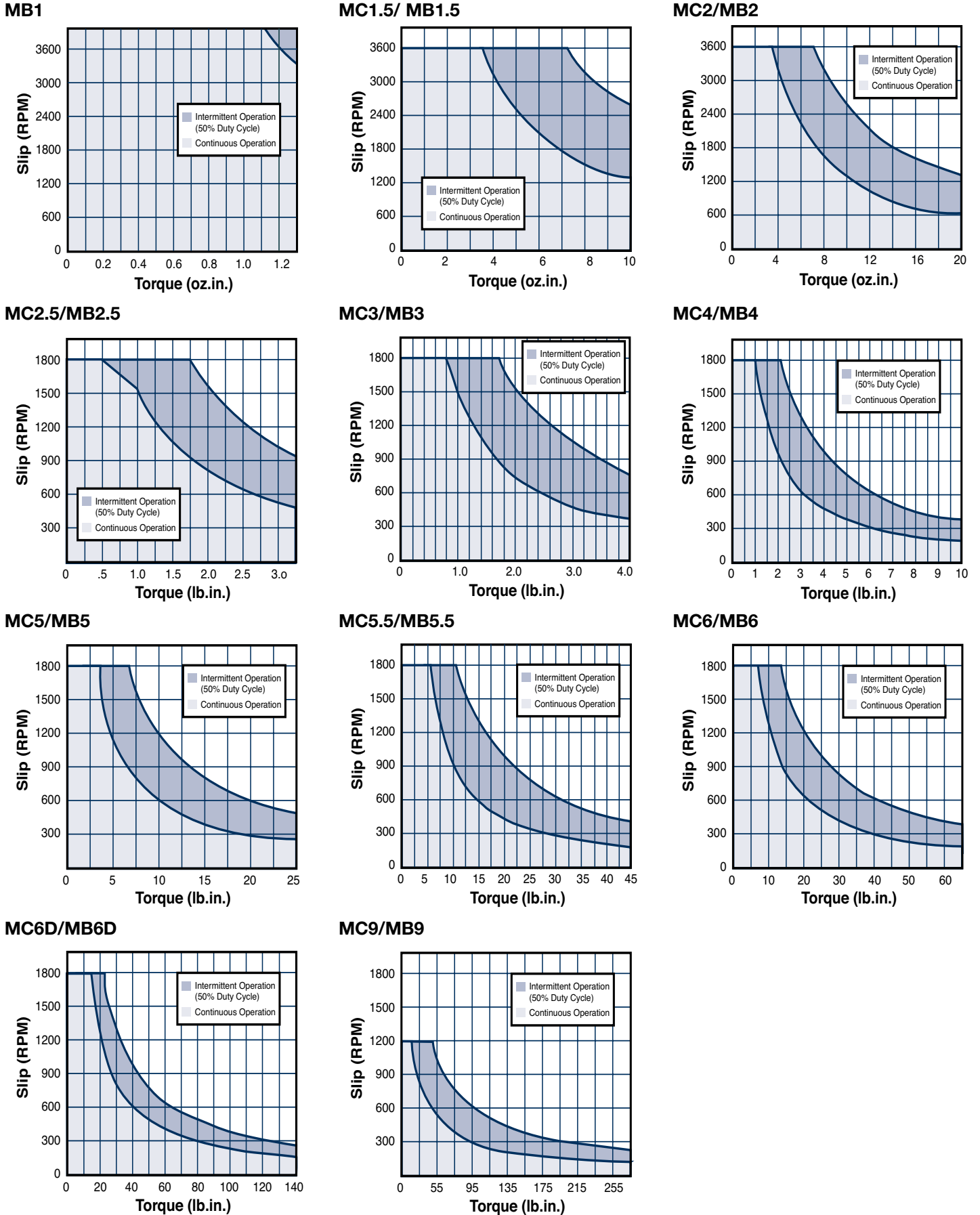

# Torque Setting Charts

**MB1**

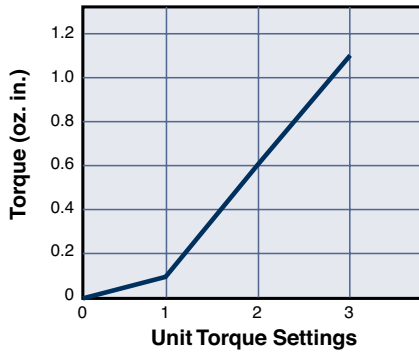

**MC2/MB2**

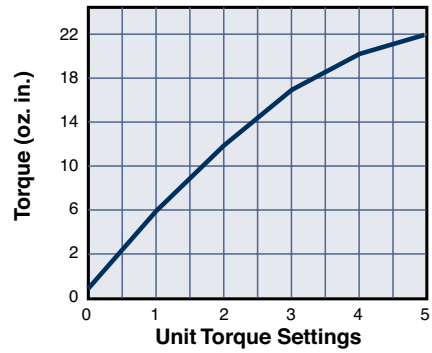

**MC2.5/MB2.5**

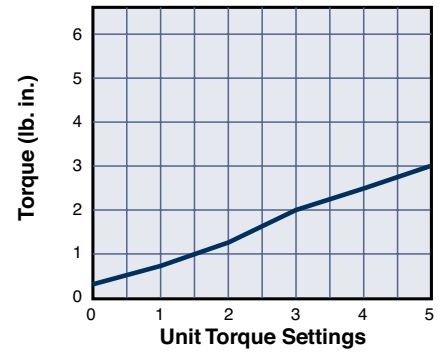

**MC3/MB3**

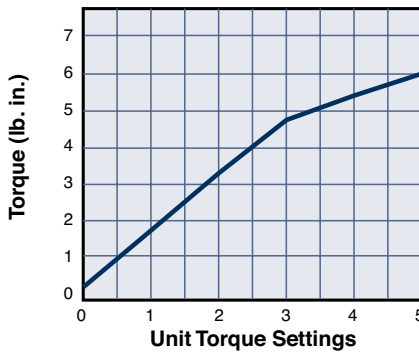

**MC4/MB4**

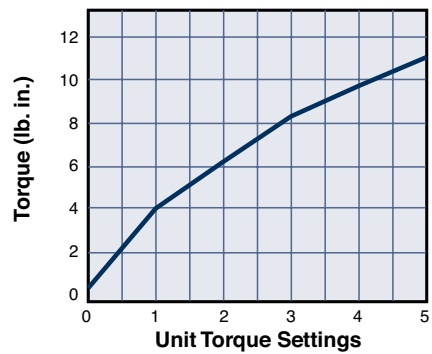

**MC5/MB5**

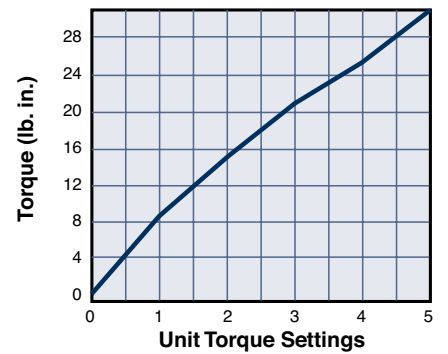

**MC5.5/MB5.5**

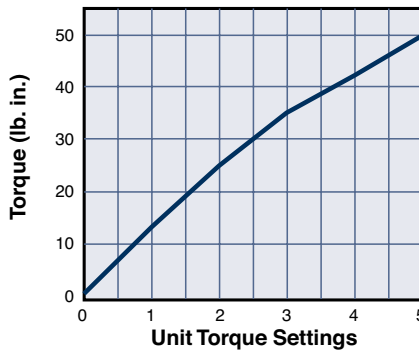

**MC6/MB6**

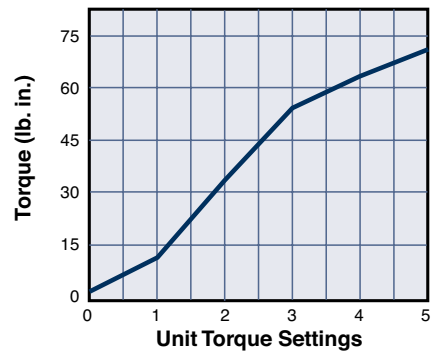

**MC6D/MB6D**

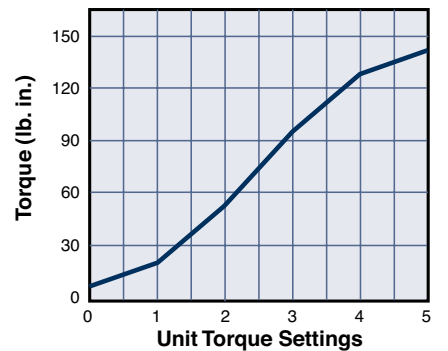

**MC9/MB9**

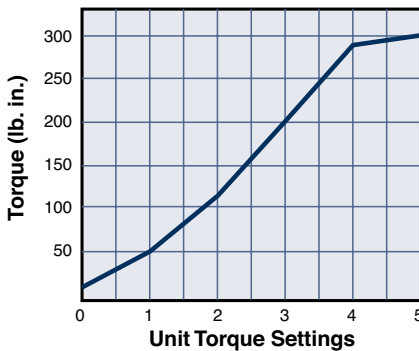

\*Torque values are approximate.

# Stub Shaft Adapters

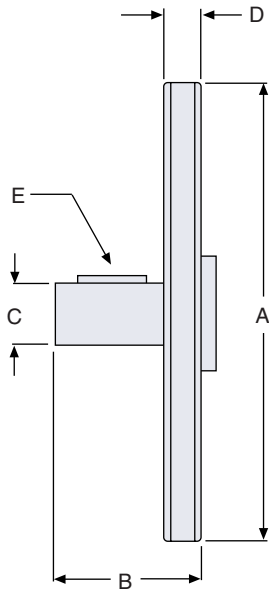

- Utilized when “clutch coupling” configuration is desired.
- Comes complete with attachment hardware and drive key.
- Stub shaft adapters should be used in conjunction with a flexible coupling.
- Also available in Stainless Steel.

Adapter Size	Permanent Magnet Model	A	B	C	D	E
A1-3/16	MB1	0.9	0.88	3/16	0.18	Flat
A2-14	MB1.5/MC1.5/MB2/MC2	1.60	0.78	1/4	0.15	Flat
A2-58	MB1.5/MC1.5/MB2/MC2	1.60	1.15	5/8	0.15	3/16” Key
A3-38	MB3/MC3	2.36	1.19	3/8	0.19	Flat
A4-38	MB4/MC4	2.86	1.19	3/8	0.19	Flat
A4-58	MB4/MC4	2.86	1.19	5/8	0.19	3/16” Key
A5-1	MB5/MC5/MB5.5/MC5.5	3.45	1.72	1	0.27	1/4” Key
A5-12	MB5/MC5/MB5.5/MC5.5	3.45	1.47	1/2	0.27	1/8” Key
A6-34	MB6/MC6	3.40	1.70	3/4	0.35	3/16” Key
A6D-34	MB6D/MC6D/MB9/MC9	4.65	2.50	3/4	0.50	3/16” Key

\*If Solid Shaft Series is used with adapter, thumb screw must be removed and replaced with set screws.

## How to Order

### 1. Torque:

Determine the maximum torque that your application requires. See the application example.

### 2. Energy Dissipation:

Determine the amount of energy or heat that will be generated during operation. Each clutch or brake is rated for a specific amount of ener-

gy, given in units of watts, that it can safely dissipate. Energy calculations for common applications are listed in the applications section.

### 3. Model Selection:

Select the clutch or brake based on torque and energy requirements. See the specifications under “Heat Dissipation and Torque Setting Charts.”

### 4. Select Bore Size:

Select the proper bore size for the application. Although many standard bores are available, consult the factory if your bore requirement is not listed.

### 5. Example:

Torque Requirement – 9 lb.in.  
Energy Requirement – 35 watts  
Bore Requirement – 5/8 inch  
Select Model MC5-58



**Application Notes**

---

---

---

---

---

---

---

---

---

---

---

---

---

---

---

---

---

---

---

---

---

---

---

---

---

---

---

---

---

---

# Magnetic Particle Clutches and Brakes

Accurate torque control with instantaneous engagement!

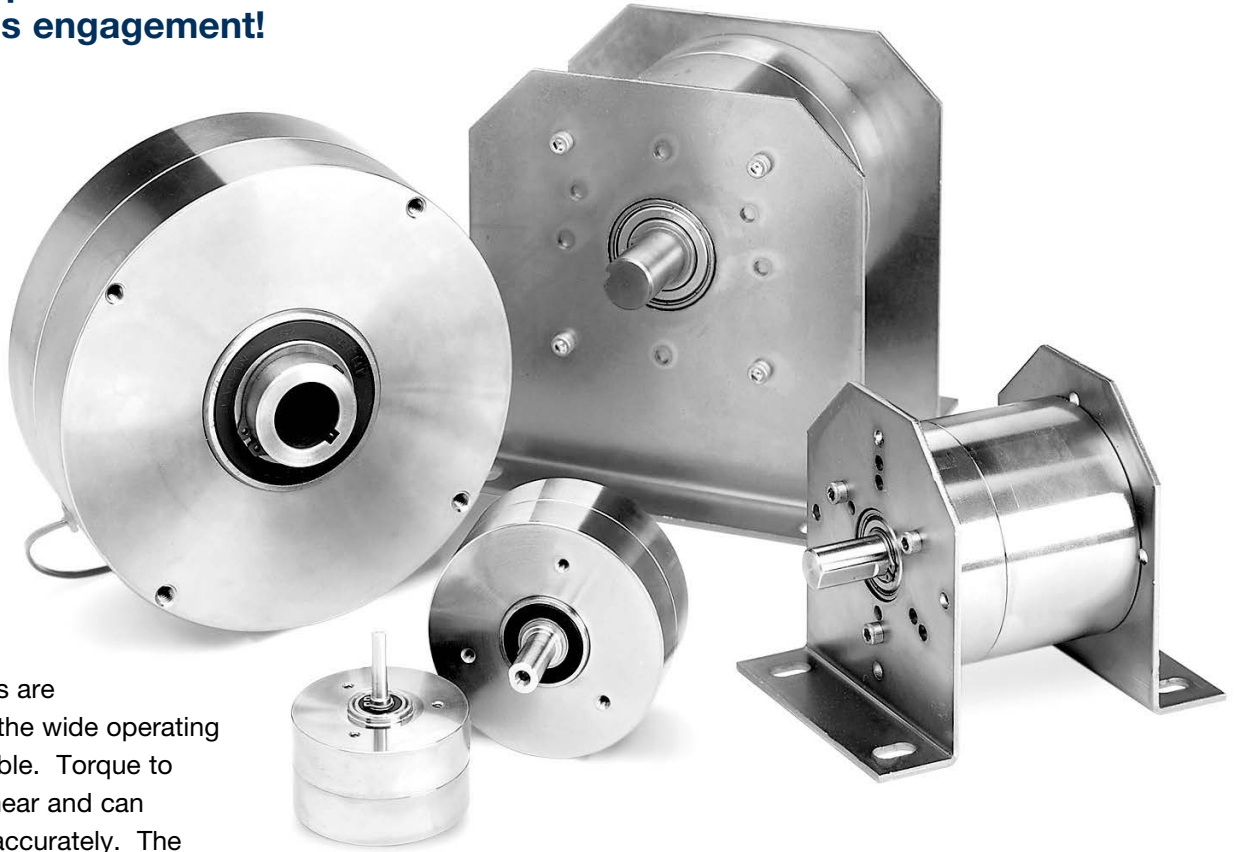

Warner Electric Precision Tork magnetic particle clutches and brakes are unique because of the wide operating torque range available. Torque to current is almost linear and can be controlled very accurately. The unique features of the magnetic particle clutches and brakes make them ideal for tension control, load simulation, cycling/indexing, and soft starts and stops.

## Specials are our business

- **Special Shaft Configurations**

Customer specified shaft configurations for easy machine mounting and retrofitting.

- **Special Torque**

Maximum torque configurations to meet customer specifications.

- **Special Mounting Configurations**

Customer specified bolt patterns, special mounting brackets.

- **Metric units**

## Features and Benefits

- **Torque independent of slip speed**

Torque is transmitted through magnetic particle chains which are formed by an electromagnetic field. The torque is independent of slip speed, depending only on circuit current, and is infinitely variable from 0 (disengaged) to rated torque.

- **Precise engagement**

Precision Tork magnetic particle clutches and brakes engage to transmit torque with speed and precision. Response of the particles to the field is virtually instantaneous, providing perfectly controlled, jerk-free engagement.

- **Customer specified engagement**

Engagement time may be very gradual or extremely fast. The frequency and torque of the engagement/disengagement sequence is limited only by the capabilities of the control circuitry.

- **No wearing parts**

There are no friction surfaces to grab or wear, and the units are not affected by changes in atmospheric or other environmental conditions.

- **Efficient/Compact design**

High torque to size ratio and low consumption of electric power.

- **Versatile mounting**

Convenient bolt circle for easy mounting. Mounting brackets available for all sizes. Brakes are available with solid shafts and through bore. Can be mounted horizontally or vertically to solve virtually any motion control requirement.

- **Distributor Item**

Off the shelf availability. Interchangeable with industry standard sizes.

The inside story.

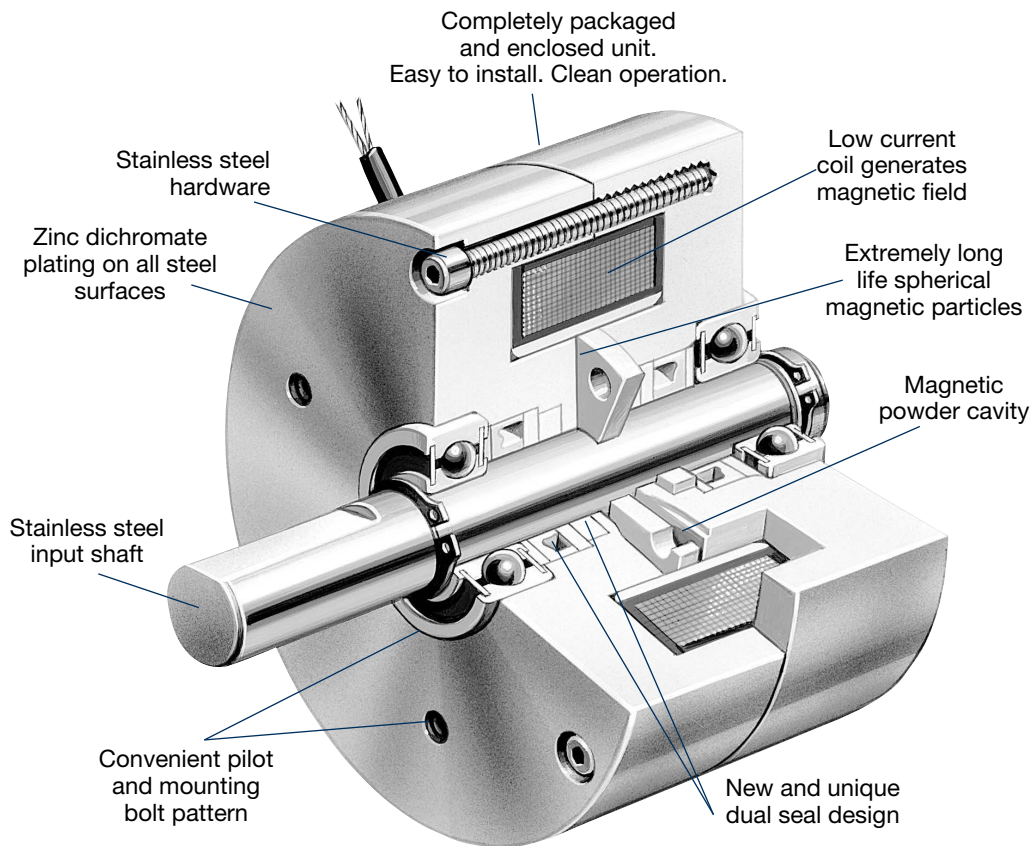

## Operating Principles

The magnetic particle unit consists of four main components: 1) housing; 2) shaft/disc; 3) coil and 4) magnetic powder. The coil is assembled inside the housing. The shaft/disc fits inside the housing/coil assembly with an air gap between the two; the air gap is filled with fine magnetic powder.

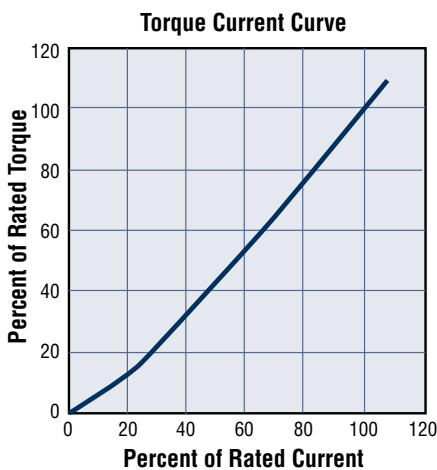

## Engagement

When DC current is applied to the magnetic particle unit, a magnetic flux (chain) is formed, linking the shaft/disc to the housing. As the current is increased the magnetic flux becomes stronger, increasing the torque. The magnetic flux creates extremely smooth torque and virtually no "stick-slip".

## Disengagement

When DC current is removed the magnetic powder is free to move within the cavity, allowing the input shaft to rotate freely.

## Cycling

By turning the current to the coil on and off a cycling effect is achieved.

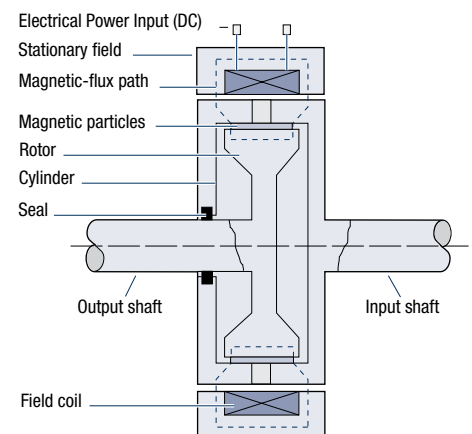

# Selection

## Sizing

To properly size magnetic particle clutches or brakes the thermal energy (slip watts) and torque transmitted must be considered. If thermal energy and torque are known for the application select the unit from the charts to the right.

### RPM

RPM must be known when calculating thermal energy (slip watts). For load simulation, torque limiting and similar applications, RPM is known. For web handling, the RPM is calculated as follows:

$$\text{Slip RPM}^* = \frac{12 \times \text{Velocity (feet per min.)}}{\pi \times \text{Full Roll Dia.}^{**} \text{ (in.)}}$$

\*In rewind applications the motor RPM should be higher (10%) than the fastest spool RPM.

\*\*In applications with the web running over a pulley or in a nip roll application use the pulley diameter as the roll diameter.

### Thermal Energy (slip watts)

Tension applications are considered continuous slip applications. When a brake or clutch is slipping, heat is generated. Heat is described in terms of "energy rate" and is a function of speed, inertia, and cycle rate. Heat generated is usually described in terms of thermal energy or slip watts. Starting and stopping applications generate heat when the unit slips during the stopping and starting of the load.

- For continuous slip applications, such as tension control in an unwind or rewind application slip watts are calculated using the following formula:

$$\text{Slip Watts} = .0118 \times \text{Torque (lb.in.)} \times \text{Slip RPM}$$

- For cycling applications heat is generated intermittently, and is calculated using the following formula:

$$\text{Watts} = \frac{2.67 \times \text{Inertia (lb.in.}^2\text{)}}{\left(\frac{\text{RPM}^2}{10,000}\right) \times F} \times \frac{\text{cycle}}{\text{min.}}$$

### Duty Cycle

The average heat input must be below the clutch or brake's heat dissipation rating. If the application generates intermittent heat dissipation, use the average speed for the thermal energy (slip watts) calculations.

## Quick Selection Charts

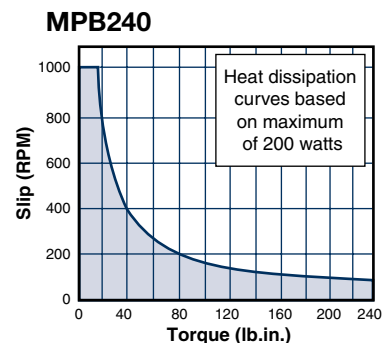
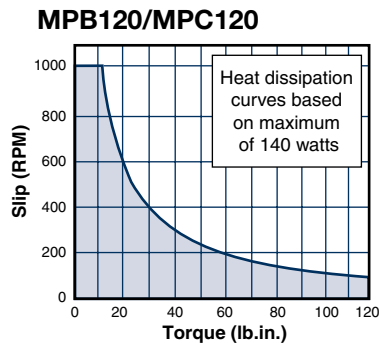
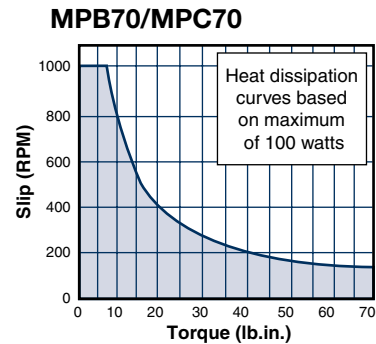
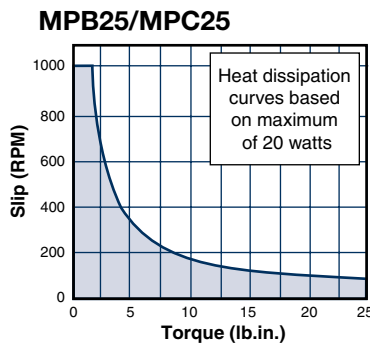
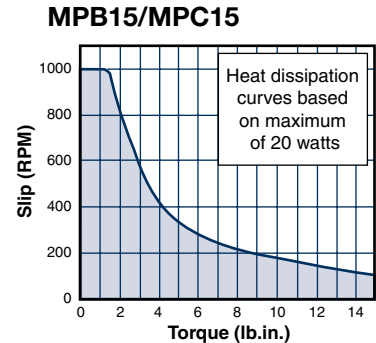
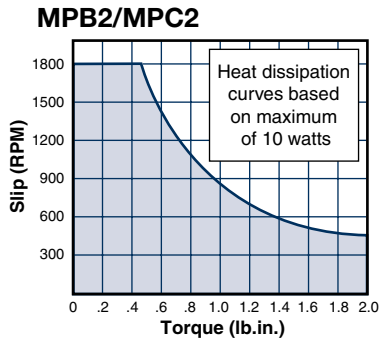

### Torque

Tension applications calculate torque as a function of roll radius and tension. Soft/controlled stopping applications calculate torque as a function of inertia, speed and desired time to stop the load. Torque limiting applications calculate torque as the allowable drive through torque. Calculate the torque requirement based on the formulas for the different applications:

- To calculate torque for a web handling application, determine the desired tension in the web then calculate the required torque as follows:

$$\text{Torque (lb.in.)} = \frac{\text{Tension (lbs.)} \times \text{Roll Dia.}^* \text{ (in.)}}{2}$$

\*Use full roll diameter. In applications with the web running over a pulley or in a nip roll application use the pulley diameter as the roll diameter.

- To calculate torque for soft/controlled stop or cycling applications first determine the inertia ( $WR^2$ ), and apply it to the formula below:

$$\text{Torque (lb.in.)} = \frac{\text{Inertia (lb.in.}^2\text{)} \times \text{RPM}}{3,690 \times \text{time(s)}}$$

$$\text{Inertia (WR}^2\text{)} = [(\text{weight of body}) \times (\text{radius of gyration}^*)]^2$$

\*to calculate for a cylinder about its axis:

$$\text{Solid cylinder} = R^2 = 1/2r^2$$

$$\text{Hollow cylinder} = R^2 = 1/2(r_1^2 + r_2^2)$$



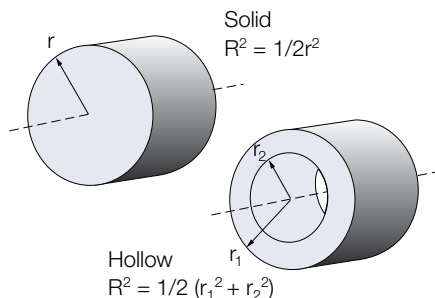

### Reflected Inertia (rotational)

In mechanical systems it is common for the rotating parts to operate at different speeds. In clutch and brake applications the  $WR^2$  is calculated for each part operating at different speeds then reduced to and equivalent  $WR^2$  at the clutch or brake mounting shaft speed. All the rotating parts'  $WR^2$  are added together and treated as a unit.

The formula for determining the equivalent  $WR^2$  of a rotating part referred to the clutch or brake shaft is as follows:

$$WR_e^2 = WR^2 \times \left(\frac{N}{N_{cb}}\right)^2$$

Where:

$WR^2$  = inertia of the rotating part at N (RPM)

N = speed (RPM) of the rotating part

$N_{cb}$  = speed (RPM) of the clutch or brake shaft

### Reflected Inertia (linear)

In complex systems involving both linear and rotating motion, the linearly moving parts can be reduced to the clutch or brake speed by the following equation:

$$WR_e^2 = W \times \frac{V^2}{(2\pi N)^2}$$

Where:

W = Weight of body

V = Velocity in feet per minute

N = RPM of the clutch or brake shaft

This equation can only be used when the linear speed has a continuous fixed relation to the rotating speed, such as a conveyor driven by a motor.

To determine torque in an overload protection, torque limiting or soft start application use the following equation:

$$\text{Torque (lb.in.)} = \frac{\text{HP} \times 63,000}{\text{RPM}}$$

## Tension Value Chart

Material	tn (lbs.in. of web width)
Aluminum foils	0.5 to 1.5 (1.0 aver.)/mil
Cellophanes	0.5 to 1.0/mil
Acetate	0.5/mil
Mylar (Polyester)	0.25 to 0.30/mil
Polyethylene	0.25 to 0.30/mil
Polypropylene	0.25 to 0.30/mil
Polystyrene	1.0/mil
Saran	0.05 to 0.20 (0.10 aver.)/mil
Vinyl	0.05 to 0.20 (0.10 aver.)/mil

### Paper and Laminations

20#/R—32.54 gm/m <sup>2</sup>	0.50 to 1.0
40#/R—65.08 gm/m <sup>2</sup>	1.0 to 2.0
60#/R—97.62 gm/m <sup>2</sup>	1.5 to 3.0
80#/R—130.0 gm/m <sup>2</sup>	2.0 to 4.0

### Paper

15 lbs./ream (3,000 sq. ft.)	0.5
20 lbs./ream	0.75
30 lbs./ream	1.0
40 lbs./ream	1.5
80 lbs./ream	2.5

### Laminations

25 lb. paper/.005"	
PE/.00032" FOIL/.001" PE	3.0
.001" Cello/.0005" PT/.001"	
Cello	1.5

When these substrates are coated with polyethylene, nylon polypropylene EVA, EAA, and EEA, add the following tension to the values listed above for the substrate only.

### Coating Thickness

0.0005" to 0.0001	0.12
0.0011" to 0.002	0.25

Material	tn (lbs.in. of web width)
----------	---------------------------

### Cellophane

.00075"	0.5
.001"	0.75
.002"	1.0

### Nylon and Cast Propylene (non-Oriented)

.00075"	0.15
.001"	0.25
.002"	0.5

### Paperboard

8 pt.	3.0
12 pt.	4.0
15 pt.	5.0
20 pt.	7.0
25 pt.	9.0
30 pt.	11.0

### Mylar and Oriented Propylene

0.0005"	0.25
0.001"	0.5
0.002"	1.0

Material	tn (lbs./strand)
----------	------------------

### Aluminum Wire

#20 AWG	4.00
#18 AWG	5.50
#16 AWG	9.00
#14 AWG	10.00
#12 AWG	12.00
#10 AWG	15.00
#8 AWG	25.00

### Copper Wire

#20 AWG	8.00
#18 AWG	10.00
#16 AWG	12.00
#14 AWG	15.00
#12 AWG	18.00
#10 AWG	20.00
#8 AWG	25.00

## Calculating Web Tension

For sizing brakes on applications in which the applied web tension is unknown, use the following information to determine the approximate tension value.

$$\text{Applied Web Tension (lbs.)} = \text{Approx. Material Tension (lb.in.)}$$

x Roll Width (in.)

### Example:

The tension for a twelve inch wide roll of 20# paper stock is unknown. What is the prescribed tension?

## Solution:

The approximate tension value as noted in the chart above for 20# paper stock is 0.75 lb.in.; thus the tension for this application is (0.75 lb.in. x 12) = 9 lbs.

# Applications

Warner Electric Precision Tork magnetic particle clutches and brakes are the ideal solution for controlling and maintaining torque. If the application is tensioning, load simulation, torque limiting, or soft starts and stops the magnetic particle unit is the preferred torque controlling device.

## Typical Applications

- Wire Processing (winding, hooking, cutting)
- Paper/Foil/Film Processing
- Labeling Applications
- Textile Processing
- Material Processing
- Load profile simulation on:
  - Exercise Equipment
  - Flight Simulators
  - Healthcare Equipment
- Life testing on:
  - Motors
  - Gears
  - Pulleys
  - Belts
  - Chains
  - Many other Rotating Devices
- Conveyors
- Bottle Capping

## Controlled Acceleration/Deceleration

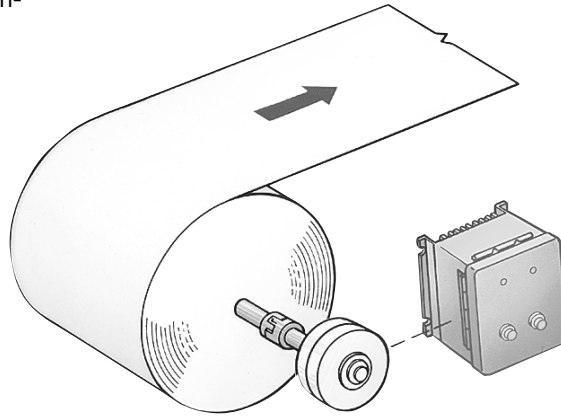

### Controlled soft stop

Particle brakes and the MCS-153 control provide soft stopping of large rotating loads. By controlling the input current, the load is decelerated in a controlled manner without torque spikes, shock, or vibration.

#### Application Example:

Information Required:  
 RPM: 1,000  
 Time to Stop: 3 seconds  
 Inertia\*: 400 lb.in.<sup>2</sup>

\*If inertia is not known see page 3 to calculate.

#### How to Size:

$$\begin{aligned} \text{Maximum Torque (lb.in.)} &= \\ &= \frac{\text{Inertia (lb.in.}^2\text{)} \times \text{RPM}}{3,690 \times \text{time(s)}} \\ &= \frac{400 \times 1,000}{3,690 \times 3} \\ &= 36 \text{ lb-in} \end{aligned}$$

Select a brake that exceeds the maximum torque requirements from the Specification Chart – MPB70.

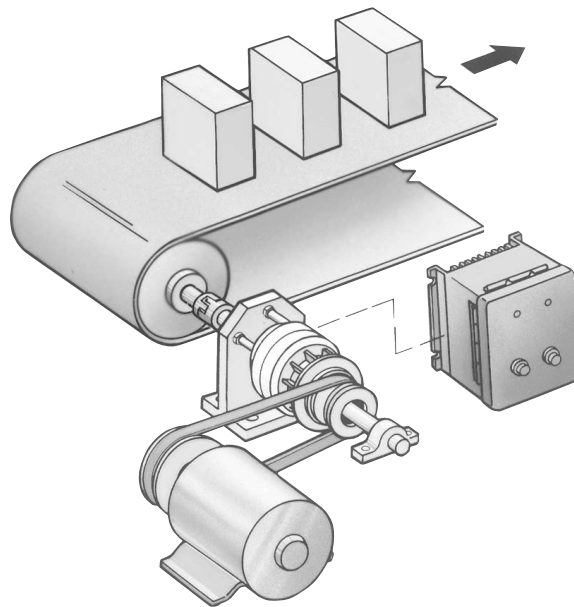

### Controlled soft start

Particle clutches and the MCS-153 control provide soft controlled acceleration to prevent tipping or shock during start up.

#### Application Example:

Information Required:  
 RPM: 500  
 Time to Start: 4 sec.  
 Inertia\*: 50 lb.in.<sup>2</sup>

\*If inertia is not known see page 3 to calculate

#### How to Size:

$$\begin{aligned} \text{Maximum Torque (lb.in.)} &= \\ &= \frac{\text{Inertia (lb.in.}^2\text{)} \times \text{RPM}}{3,690 \times \text{time(s)}} \\ &= \frac{50 \times 500}{3,690 \times 4} \\ &= 1.7 \text{ lb.in.} \end{aligned}$$

Select a clutch that exceeds the maximum torque requirements from the Specification Chart – MPC2.

## Tensioning

Magnetic Particle clutches and brakes offer smooth controlled torque for tensioning in both the unwind zone and rewind zone. Torque produced from the magnetic particle clutches and brakes is independent of slip speed, offering a distinct advantage over competing technologies. Since torque can be varied infinitely by varying the input current, the magnetic particle clutches and brakes are ideal in an open loop system. To close the loop in the tensioning system, combine the magnetic particle clutch or brake with a Warner® sensor and control, resulting in more precise control of tension.

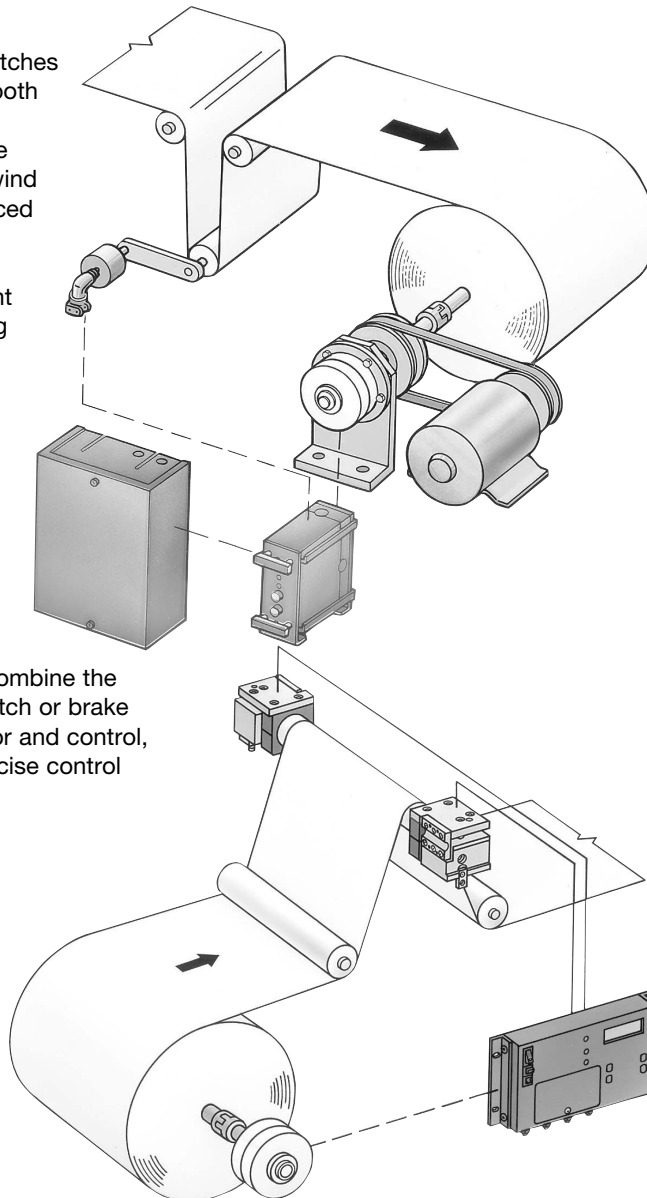

## Rewind stand under dancer control

Particle clutches and the MCS-203 control provide accurate closed loop tension control for rewind applications.

### Application Example:

Information Required:

Core Diameter: 3 inches  
 Full Roll Diameter: 9 inches  
 Tension: 5 lbs.  
 Velocity: 300 fpm  
 Input RPM: 500 RPM\*

$$\text{Maximum Torque (lb.in.)} = \frac{\text{tension (lbs.)} \times \text{full roll diameter (in.)}}{2}$$

$$= \frac{5 \times 9}{2}$$

$$= 23 \text{ lb-in}$$

$$\text{Core RPM} = \frac{12 \times \text{Velocity (fpm)}}{\pi \times \text{core diameter}}$$

$$= \frac{12 \times 300}{\pi \times 3}$$

$$= 382 \text{ RPM}$$

$$\text{Full Roll RPM} = \frac{12 \times \text{Velocity (fpm)}}{\pi \times \text{Full Roll Dia.}}$$

$$= \frac{12 \times 300}{\pi \times 9}$$

$$= 127 \text{ RPM}$$

$$\text{Slip RPM} = \text{Input RPM} - \text{Full Roll RPM}$$

$$= 500 - 127$$

$$= 372.68$$

$$\text{Thermal Energy (slip watts)} =$$

$$= .0118 \times \text{Torque} \times \text{Slip RPM}$$

$$= .0118 \times 22 \times 373$$

$$= 99 \text{ watts}$$

Select a clutch that exceeds the maximum torque and thermal energy requirements from the Quick Selection Chart – MPC120.

\*To maximize tension control and minimize heat generated, select a drive system that will result in an actual input speed as close to, but not less than, 30 RPM greater than the core RPM. In this example, 382 + 30 = 412, would be ideal but 500 RPM was more readily available.

## Unwind stand under load cell control

Particle brakes and the TCS-240 load cell control with precision load cell sensors provide closed loop tension control.

### Application Example:

Information Required:

Full Roll Diameter: 20 inches  
 Tension: 5 lbs.  
 Velocity: 400 fpm

### How to Size:

$$\text{Maximum Torque (lb.in.)} = \frac{\text{Full roll diameter (in.)} \times \text{tension (lbs.)}}{2}$$

$$= \frac{20 \times 5}{2}$$

$$= \frac{100}{2}$$

$$= 50 \text{ lb.in.}$$

$$\text{Slip RPM} = \frac{\text{Velocity (fpm)} \times 12}{\text{Full roll diameter} \times \pi}$$

$$= \frac{400 \times 12}{20 \times \pi}$$

$$= 76 \text{ RPM}$$

$$\text{Thermal Energy (Slip Watts)} =$$

$$.0118 \times \text{Torque (lb.in.)} \times \text{RPM}$$

$$= .0118 \times 50 \times 76$$

$$= 45 \text{ Watts}$$

Select a brake that exceeds the maximum torque and thermal energy requirements from Quick Selection Chart – MPB70.

# Applications

## Torque Limiting/ Overload Protection

The magnetic particle clutches and brakes combined with a Warner® CBC control are effective means to providing protection in the case of jam ups. The magnetic particle clutch and the CBC control can provide precise adjustable torque in torque limiting applications.

### Application Example

Information Required:

Motor HP: 1 HP  
Motor RPM : 700 RPM

### How to Size:

$$\begin{aligned} \text{Maximum Torque (lb.in.)} &= \\ &= \frac{\text{HP} \times 63,000}{\text{RPM}} \\ &= \frac{1 \times 63,000}{700} \\ &= 90 \text{ lb.in.} \end{aligned}$$

Select a clutch that exceeds the maximum torque requirements from the Selection Chart – MPC120.

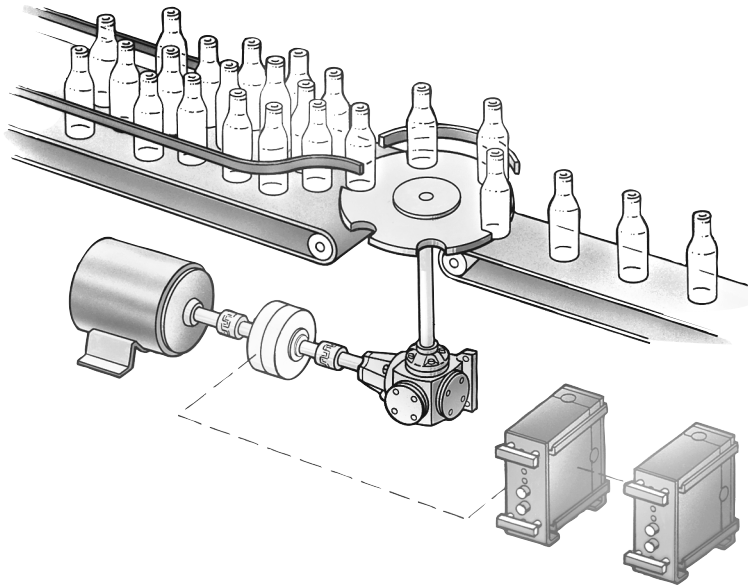

## Load Simulation

By combining the magnetic particle brake with a microprocessor control, virtually any load simulation can be obtained. The control is programmed with the profile or condition that is to be simulated. The control then feeds the profile to the magnetic particle brake in terms of input current. The brake reads the input current and provides load torque to simulate the condition.

If the application requires programming load profiles, adjusting load torque, or simulating friction or drag loads, the magnetic particle clutches and brakes are the ideal solution.

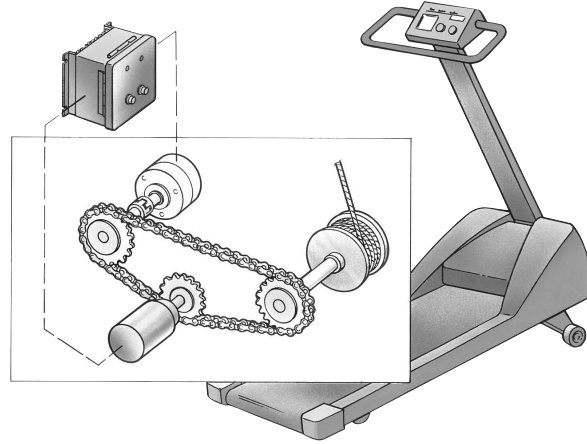

### Exercise Equipment

Brake models provide a smooth controllable resistance for exercise machines. When integrated with a microprocessor control, programming load profiles is possible.



# Dimensions and Specifications

## Clutches

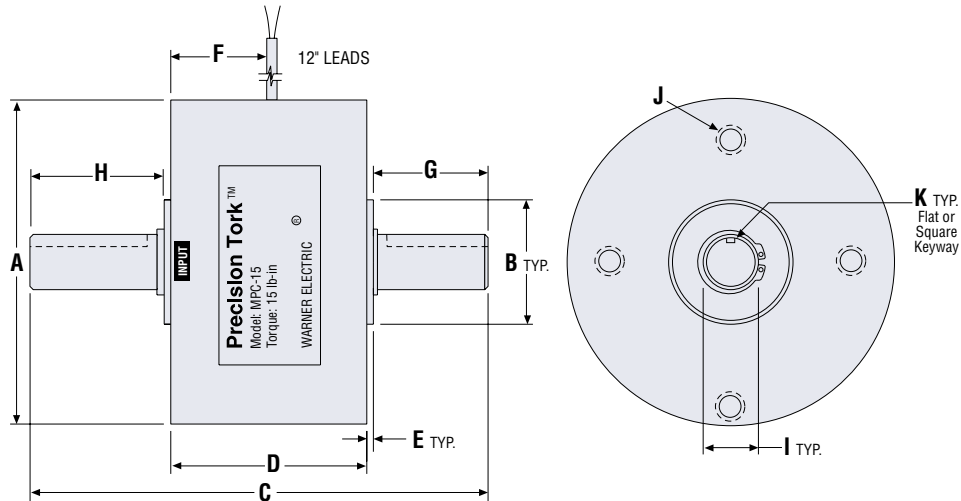

## Dimensions

Model	A	B	C	D	E	F	G (Output)	H (Input)	I	J	K5
MPC2-1	2.11	0.750/0.749	3.73	1.85	0.06	1.16	0.88	0.88	0.2498/0.2492	(3) #6-32 x 0.50 on 1.350 BC	Flat
MPC15-1	2.96	1.125/1.124	4.93	2.80	0.07	1.69	1.00	1.00	0.4998/0.4992	(3) #8-32 x 0.50 on 2.000 BC	Flat
MPC15-2	2.96	1.125/1.124	5.08	2.80	0.07	1.69	1.22	0.92	0.3748/0.3742	(3) #8-32 x 0.50 on 2.000 BC	Flat
MPC25-1	2.96	1.125/1.124	4.93	2.80	0.07	1.69	0.995	1.00	0.4998/0.4992	(3) #8-32 x 0.50 on 2.000 BC	2 Flats at 90°
MPC25-2	2.96	1.125/1.124	5.08	2.80	0.07	1.69	1.22	0.92	0.3748/0.3742	(3) #8-32 x 0.50 on 2.000 BC	2 Flats at 90°
MPC70	4.58	1.625/1.624	6.55	3.67	0.10	2.08	1.35	1.35	0.7497/0.7492	(4) #10-32 x 0.63 on 4.228 BC	0.188 Keyway
MPC120	5.25	1.625/1.624	7.02	4.00	0.10	2.40	1.50	1.35	0.7497/0.7492	(4) #1/4-20 x 0.75 on 4.812 BC	0.188 Keyway

## Specifications

Model Number	Max. Drag Torque 0 Excit. (lb.in.)	Rated Torque (lb.in.)	Rated Voltage	Resistance (Ohms)	Rated Current (Amps)	Response Zero Force (Millisec)	Response With Force (Millisecs)	Inertia of Output Shaft (lb.in.2)	Max. Heat Dissipation (watts)	Max. Speed Recom. (RPM)	Weight
MPC2	0.40	2	24	92	0.261	8	4	0.001	10	1,800	2
	0.40	2	90	1552	0.058	8	4	0.001	10	1,800	2
MPC15	0.40	15	24	80	0.302	25	9	0.013	20	1,000	5.5
	0.40	15	90	1501	0.060	25	9	0.013	20	1,000	5.5
MPC25	0.40	25	24	45	0.533	25	9	0.013	20	1,000	5.5
MPC70	1.00	70	24	35	0.677	70	17	0.073	100	1,000	16
	1.00	70	90	613	0.147	70	17	0.073	100	1,000	16
MPC120	2.00	120	24	33	0.742	90	25	0.370	140	1,000	22
	2.00	120	90	475	0.190	90	25	0.370	140	1,000	22

## Optional Mounting Bracket (for mounting MPB Brakes and MPC Clutches)

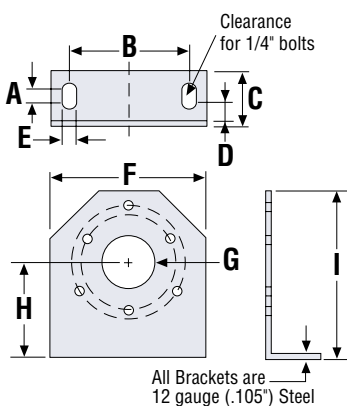

Model	Fits Size	A	B	C	D	E	F	G	H	I
MPB-2B	2	0.270 (6.9)	1.750 (44.5)	1.155 (29.3)	0.390 (9.9)	0.280 (7.1)	2.500 (63.5)	0.755 (19.2)	1.500 (38.1)	3.000 (76.2)
MPB-15B	15, 25	0.270 (6.9)	2.500 (63.5)	1.155 (29.3)	0.390 (9.9)	0.280 (7.1)	3.500 (88.9)	1.13 (28.7)	2.000 (50.8)	4.000 (101.6)
MPB-70B	70	0.270 (6.9)	4.875 (123.8)	1.155 (29.3)	0.390 (9.9)	0.280 (7.1)	6.000 (152.4)	1.63 (41.4)	3.500 (88.9)	6.000 (152.4)
MPB-120B	120	0.270 (6.9)	4.875 (123.8)	1.155 (29.3)	0.390 (9.9)	0.280 (7.1)	6.000 (152.4)	1.63 (41.4)	3.500 (88.9)	6.250 (158.8)
MPB-240B	240	0.270 (6.9)	4.875 (123.8)	1.155 (29.3)	0.390 (9.9)	0.280 (7.1)	6.500 (165.1)	2.245 (62.1)	4.000 (101.6)	7.500 (190.5)

All dimensions are nominal unless otherwise noted. ( ) denotes (mm)

# Dimensions and Specifications

## Brakes

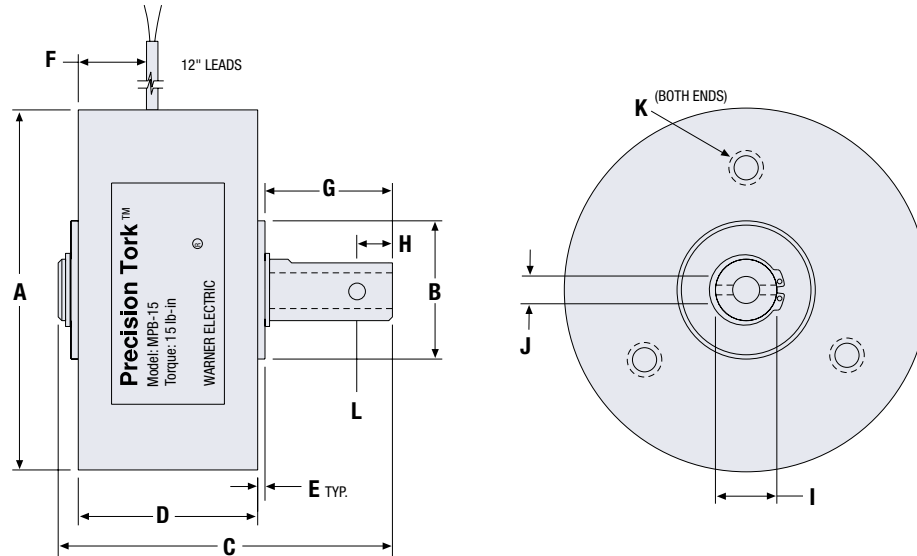

## Dimensions

Model	A	B	C	D	E	F	G	H	I (Shaft)	J (Bore)	K	L
MPB2-1	2.11	0.750/0.749	2.23	1.15	0.06	0.70	0.87	-	0.2498/0.2492	-	(3) #6-32 x 0.27 on 1.350 BC	1 Flat
MPB15-1	2.96	1.125/1.124	3.05	1.46	0.07	0.85	1.35	-	0.3748/0.3742	-	(3) #8-32 x 0.30 on 2.000 BC	2 Flats at 90°
MPB15-2	2.96	1.125/1.124	2.05	1.46	0.07	0.85	0.34	0.18	-	0.375/0.376	(3) #8-32 x 0.30 on 2.000 BC	0.125 Thru Hole
MPB15-3	2.96	1.125/1.124	2.70	1.46	0.07	0.85	0.99	-	0.4998/0.4992	-	(3) #8-32 x 0.30 on 2.000 BC	2 Flats at 90°
MPB25-1	2.96	1.125/1.124	2.05	1.46	0.07	0.85	1.35	-	0.3748/0.3742	-	(3) #8-32 x 0.30 on 2.000 BC	2 Flats at 90°
MPB25-2	2.96	1.125/1.124	2.05	1.46	0.07	0.85	0.34	0.18	-	0.375/0.376	(3) #8-32 x 0.30 on 2.000 BC	0.125 Thru Hole
MPB25-3	2.96	1.125/1.124	2.7	1.46	0.07	0.85	0.99	-	0.4998/0.4992	-	(3) #8-32 x 0.30 on 2.000 BC	2 Flats at 90°
MPB70-1	4.57	1.625/1.624	2.62	1.76	0.10	0.98	0.50	0.18	-	0.500/0.501	(4) #10-32 x 0.50 on 4.228 BC	0.125 Thru Hole
MPB70-2	4.57	1.625/1.624	3.37	1.76	0.10	0.98	1.25	-	0.7497/0.7492	-	(4) #10-32 x 0.50 on 4.228 BC	0.188 Keyway
MPB120-1	5.25	1.625/1.624	4.02	2.17	0.10	1.18	1.50	0.50	-	0.500/0.501	(4) #1/4-20 x 0.75 on 4.812 BC	0.156 Thru Hole
MPB120-2	5.25	1.625/1.624	4.02	2.17	0.10	1.18	1.50	-	0.7497/0.7492	-	(4) #1/4-20 x 0.75 on 4.812 BC	0.188 Keyway
MPB240-1	6.23	2.442/2.440	4.66	2.65	0.10	1.46	1.65	-	0.7497/0.7492	-	(4) #1/4-20 x 0.65 on 5.875 BC	0.188 Keyway
MPB240-2	6.23	2.442/2.440	3.51	2.65	0.10	1.46	0.50	-	-	0.875/0.876	(4) #1/4-20 x 0.65 on 5.875 BC	0.188 Keyway
MPB240-3	6.23	2.442/2.440	3.51	2.65	0.10	1.46	0.50	-	-	1.000/1.001	(4) #1/4-20 x 0.65 on 5.875 BC	0.250 Shallow Keyway

## Specifications

Model Number	Max. Drag Torque 0 Excit. (lb.in.)	Rated Torque (lb.in.)	Rated Voltage	Resistance (Ohms)	Rated Current (Amps)	Response Zero Force (Millisec)	Response With Force (Millisecs)	Inertia of Output Shaft (lb.in.2)	Max. Heat Dissipation (watts)	Max. Speed Recom. (RPM)	Weight
MPB2	0.40	2	24	92	0.261	8	4	0.001	10	1,800	1
	0.40	2	90	1552	0.058	8	4	0.001	10	1,800	1
MPB15	0.40	15	24	80	0.302	25	9	0.013	20	1,000	2.5
	0.40	15	90	1501	0.060	25	9	0.013	20	1,000	2.5
MPB25	0.40	25	24	45	0.533	25	9	0.013	20	1,000	2.5
MPB70	1.00	70	24	35	0.677	70	17	0.073	100	1,000	8
	1.00	70	90	613	0.147	70	17	0.073	100	1,000	8
MPB120	2.00	120	24	33	0.742	90	25	0.370	140	1,000	12.5
	2.00	120	90	475	0.190	90	25	0.370	140	1,000	12.5
MPB240	4.00	240	24	19	1.286	150	45	1.311	200	1,000	20.5
	4.00	240	90	246	0.366	150	45	1.311	200	1,000	20.5

## Adjustable Torque



## TCS-200-1 Manual/Analog

The TCS-200-1/-1H single channel controls are selectable voltage or current controlled power supplies designed to power up to a 16-magnet Electro Disc tension brake system, Electromagnetic Particle Brakes, TB Series brakes, or Advanced Technology tension brakes. These controls operate from a switch-selectable power source of 115 or 230 VAC. They can be operated manually from the front panel or remotely via an analog voltage input, a current input, a remote pot, or a roll follower. External inputs are also provided for remote brake Off, Run, and Stop functions, as well as front panel control of these functions.

### Features

- Input: 115/230 VAC, 50/60 Hz
- Output: -1, 0–24 VDC adjustable, 4.25 Amps continuous
- -1H, 0–24 VDC adjustable, 5.8 Amps continuous
- Front panel torque adjust
- Front panel brake mode stop switch
- **Modes:** Stop – Brake Full On
- Run – Normal Operation
- Off – Brake Off
- Remote brake mode switch (same functions as mentioned above)
- Remote torque adjust
- Roll follower input
- 0–10 VDC analog voltage input
- 4–20mA analog current input

## System Control



## CBC200/CBC300

The CBC 200 and CBC 300 are Constant Current controls for 90 volt coil clutches and brakes. Both can control a single clutch or brake, or a clutch and brake or two clutches or two brakes. Both operate based on 120 volt AC input. The CBC 200s have one output channel adjustable and one fixed. The CBC 300s have both channels adjustable.

The CBC 200 and CBC 300 provide for potentiometer adjustment on the front of the unit as shown. The CBC 200-1 and CBC 300-1 provides for input from an external 10K ohm, 2 watt potentiometer. The CBC 200 C1 and CBC 300 C1 are chassis mount versions of the CBC 200-1 and CBC 300-1.

### Features

- Input: 115 VAC 50/60 hz
- Output: Pulse width modulated full wave rectified DC. Constant current, switch selectable ranges designed for 90 volt DC clutches and brakes.
- Circuit Protection: Internal short circuit protection on outputs, but no circuit protection for AC ground faults. Customer supplied 1.5 amps 250 VAC Fast Acting type fuse recommended.
- Status Indicators: “POWER” green LED indicating AC power is applied to the control. “SHORT” red LED indicating that a short circuit condition exists on one or both of the outputs.
- Enclosure: NEMA 1 rated.
- External switching: Mechanical or Electromechanical switching. Customer supplied 1 amp, 125 v minimum rating

## Dancer/Remote Analog Control



## MCS-203/MCS-204/MCS-166

The MCS-203 is a basic dancer control that automatically controls web tension through the use of a dancer roll and sensor. It is single channel, but can operate two 24 VDC tension brakes in parallel when using two MCS-166 power supplies.

The MCS-204 is a basic remote analog control that can also be operated manually via a front panel tension adjustment potentiometer. It is also single channel with the possibility of operating two 24 VDC tension brakes in parallel when using two MCS-166 power

supplies.

### Features

- Input: 115/230 VAC, 50/60 Hz
- Output: 0–24 VDC at 3 Amps max.
- **MCS-203 (only)**
- Full P-I-D adjustment
- System gain display
- **MCS-204 (only)**
- Front panel torque adjustment
- Remote potentiometer adjustment
- Roll follower input
- Remote voltage or current analog signal following

# Magnetic Capping Headset Replacements

Warner Electric's unique product design enables longer life for your magnetic headset.

## Spring Cover

Keeps lubrication within the unit, extends the life of the top load components.

## Grease Access Point

Easy to maintain. Lubricate the upper assembly every 500 hours.

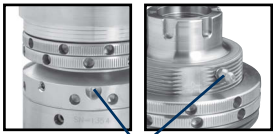

Grease Access Point

## Stainless Steel Construction, Quad Seal, and Drain Holes

The quad seal helps to protect the bearing from contaminants. The drain holes allow for an exit if any fluids get inside of the unit. These features combined with stainless steel construction enable the units to better withstand harsh environments, including caustic washdowns!

## Visual Setting Scale for Application Torque

Easy to set up and maintain. This setting scale provides easy, accurate setting of application torque.

Warner Electric capping headsets are 100% interchangeable with major OEM models including:

- ALCOA
- ZALKIN
- AROL
- FOWLER
- FOGG
- AMCO
- KRONES
- KHS



## Visual Setting Scale for Setting Top Load Force

Easy to set up. This setting scale provides easy accurate setting of top load force.

## Oversized Thrust Bearing

Specifically designed for the bottling industry with an oversized thrust bearing to handle the repeated downward thrust of capping, increasing bearing life compared to a standard radial ball bearing used by competitive models.

This bearing is not incorporated on all models.

## Smooth Torque Technology

Eliminates cap over-tightening, reduces variation in removal torque, and provides less shock wear on the system.



## Unique Dowel Pin Design

Warner Electric units utilize a four dowel pin design, reducing wear significantly when compared to the keyed design of competitive units.

# Magnetic Capping Headset Replacements

## Featuring Smooth Torque magnetic technology to provide the most consistent torque control on the market

Warner Electric magnetic headsets feature constant Smooth Torque Technology; differing with most competitor OEM headsets that have two opposing magnets causing pulsating torque. It's the pounding effect of a pulsating clutch that increases cap tightness during the capping process.

Warner Electric's Smooth Torque Technology enables Warner headsets to provide constant torque. This eliminates over tightened caps, causing a major reduction in variation of removal torque!

Smooth Torque Technology provides less shock on the system compared to pulsating torque headsets, enabling longer life of machine components, especially retention knives.

- 100% Interchangeable with Major OEM Headsets
- Smooth Torque
- Improved Efficiency
- Longer Operating Life and Lower Cost of Ownership
- Lower Operating Costs
- Easy to Set-up & Maintain
- Excellent Service Expertise and Delivery

## Easy Rebuilds!

- **Full rebuild kits available**
- **No expensive maintenance contracts**
- **Save time and money by repairing the headsets yourself**

Repair Kits	Model
Bearing Repair Kit	M4.5-BK
Magnet Repair Kit	M4.5-MK
Tool Kit	M4.5-TK

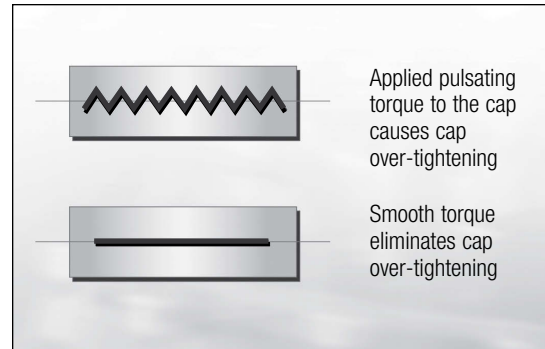

Competition variation in removal torque

Warner vs. Competitor

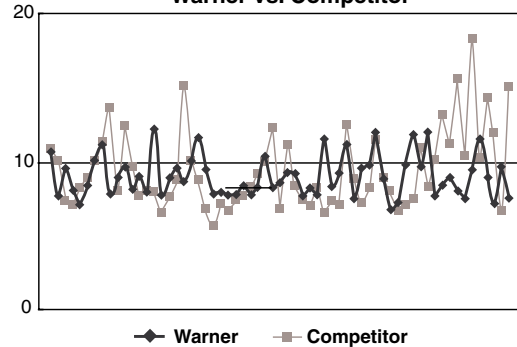

Warner variation in removal torque

Each data point is a measurement from one sample bottle from competitive headsets running on the same machine.

## Other Rebuild Options

- **Factory Repair Programs**
- **Exchange Program**
- **Ask for details**

## Many Warner headsets available off the shelf!

### Replacement Headsets for Alcoa OEM Machines

Alcoa Model	Warner Model
Magna Torq	M4.5-001
Magna Torq2000	M4.5-002
VK560	M4.5-007

### Replacement Headsets for Other Major OEM Machines

Warner Models	
<b>Zalkin</b>	M4.5-025
	M4.5-035
<b>Fogg</b>	M4.5-004
	M4.5-034
<b>AROL</b>	M4.5-010
	M4.5-027
	M4.5-032



# Capping Packages Designed for Dairy Applications

Warner Electric has recently introduced new capping packages specifically designed for the dairy industry. These products are 100% interchangeable with the OEM capping machinery found in dairy plants today. Designed to provide maximum corrosion resistance in caustic washdown environments, Warner headsets are engineered to help you reduce maintenance costs and keep your dairy plants' downtime to a minimum!

- **Designed to withstand caustic washdown environments**
  - Completely sealed unit prevents fluids from getting into the clutch
  - All Stainless steel construction
- **More consistent torque, improving quality and efficiency**
- **Reduced plant downtime**
  - Improved visual adjustment capabilities for application torque
  - Provides longer operating life than comparable OEMs
- **Lower overall operating costs**
- **Cost-effective solutions with short lead times**
- **Quieter machine operation**
- **Chucks are easily cleaned**
- **Smooth torque eliminates bottle damage from kicker fingers**



## Federal/Portola/ Blackhawk Capping System



### Warner Electric Replacement for the Federal/Portola/ Blackhawk Capping System

- NEW and improved complete capping assembly specifically designed for the dairy industry.
- 100% interchangeable with the Federal/Portola capping system.

## Federal GEM style Capping Clutch



### Warner Electric Replacement for the Federal GEM style Capping Clutch

- Direct replacement for the Federal GEM capping clutch.
- 100% Interchangeable with the Federal GEM capping clutch.

## Fogg Capping Headset



### Warner Electric Replacement for the Fogg Capping Headset

- Direct interchange for the Fogg capping headset commonly used in the dairy industry.
- 100% interchangeable, no machine modification required.

## Warner Electric is your Engineered Cap Chuck Solution

- Chucks engineered to fit your cap profile
- Manufactured to be 100% interchangeable with existing OEM chucks
- Manufactured from highly corrosion resistant hardened stainless steel material
- Unique cap chuck pin designed to better grip your cap
- Competitively priced and short lead times



### Fixed Chucks



- Simple design, least amount of wearing parts
- Low maintenance
- Low inertia
- Short lead times

### Quick Connect Chucks



- Quick changeover ideal for multiple package sizes or frequent cleaning
- Designed for any OEM headset to meet your application needs

### Mechanical Chucks



- Ideal for multiple cap sizes, difficult cap grip applications, and smooth caps
- Hardened stainless steel used in key wear areas
- Competitively priced

## Warner Electric is the Preferred Supplier for Low Profile Cap Applications



- Experienced in providing quality chucks for new low profile cap applications
- Provided one of the top performing PTOC chucks to the CSD industry
- Industry leader in providing 1881 style and Savalas low profile cap chucks
- Our extensive design experience has enabled us to engineer our chucks to reduce cocked caps









# The power of one, the strength of many.

*Other product solutions from*

## **Altra Industrial Motion**

Our comprehensive product offering is comprised of nine major categories including electromagnetic clutches and brakes, heavy duty clutches and brakes, overrunning clutches, gearing, engineered couplings, engineered bearing assemblies, linear products and belted drives. With thousands of product solutions available, Altra provides true single source convenience while meeting specific customer requirements. Many major OEM's and end users prefer Altra products as their No.1 choice for performance and reliability.

[www.altramotion.com](http://www.altramotion.com)



### **Electromagnetic Clutches and Brakes**

Warner Electric  
Inertia Dynamics  
Matrix International

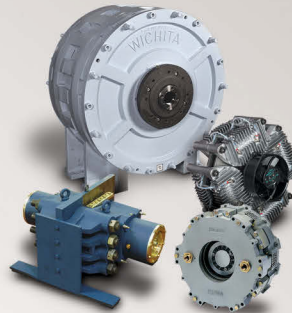

### **Heavy Duty Clutches and Brakes**

Wichita Clutch  
Twiflex Limited  
Industrial Clutch



### **Overrunning Clutches**

Formsprag Clutch  
Marland Clutch  
Stieber Clutch



### **Engineered Couplings and Universal Joints**

TB Wood's  
Ameridrives Couplings  
Ameridrives Power Transmission  
Bibby Turboflex  
Lamiflex Couplings



### **Belted Drives and Sheaves**

TB Wood's

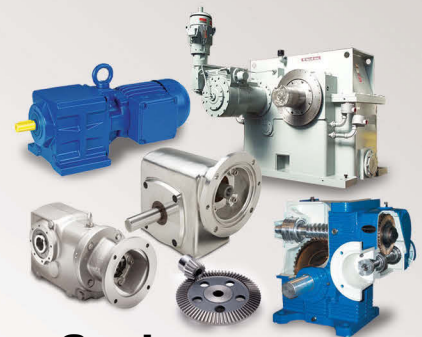

### **Gearing**

Boston Gear  
Nuttall Gear  
Delroyd Worm Gear  
Bauer Gear Motor



### **Linear Products**

Warner Linear



### **Engineered Bearing Assemblies**

Kilian Manufacturing



### **Precision Couplings and Air Motors**

Huco Dynatork

All Customer Service phone numbers shown in bold

## Electromagnetic Clutches and Brakes

### Warner Electric

*Electromagnetic Clutches and Brakes*

New Hartford, CT - USA  
1-800-825-6544

*For application assistance:*  
1-800-825-9050

St Barthelemy d'Anjou, France  
+33 (0) 2 41 21 24 24

*Precision Electric Coils and Electromagnetic Clutches and Brakes*

Columbia City, IN - USA  
1-260-244-6183

### Matrix International

*Electromagnetic Clutches and Brakes, Pressure Operated Clutches and Brakes*

Brechin, Scotland  
+44 (0) 1356 602000

New Hartford, CT - USA  
1-800-825-6544

### Inertia Dynamics

*Spring Set Brakes; Power On and Wrap Spring Clutch/Brakes*

New Hartford, CT - USA  
1-800-800-6445

## Linear Products

### Warner Linear

*Linear Actuators*

Belvidere, IL - USA  
1-800-825-6544

*For application assistance:*  
1-800-825-9050

St Barthelemy d'Anjou, France  
+33 (0) 2 41 21 24 24

## Couplings

### Ameridrives Couplings

*Mill Spindles, Ameriflex, Amerisc*

Erie, PA - USA  
1-814-480-5000

*Gear Couplings*

San Marcos, TX - USA  
1-800-458-0887

### Bibby Turboflex

*Disc, Gear, Grid Couplings, Overload Clutches*

Dewsbury, England  
+44 (0) 1924 460801

Boksburg, South Africa  
+27 11 918 4270

### TB Wood's

*Elastomeric Couplings*

Chambersburg, PA - USA  
1-888-829-6637 – Press #5

*For application assistance:*  
1-888-829-6637 – Press #7

*General Purpose Disc Couplings*

San Marcos, TX - USA  
1-888-449-9439

### Ameridrives Power Transmission

*Universal Joints, Drive Shafts, Mill Gear Couplings*

Green Bay, WI - USA  
1-920-593-2444

### Huco Dynatork

*Precision Couplings and Air Motors*

Hertford, England  
+44 (0) 1992 501900

Chambersburg, PA - USA  
1-888-829-6637

### Lamiflex Couplings

*Flexible Couplings, Bearing Isolators, and Coupling Guards*

São Paulo, SP - Brasil  
+55-11-5679-6533

## Heavy Duty Clutches and Brakes

### Wichita Clutch

*Pneumatic Clutches and Brakes*

Wichita Falls, TX - USA  
1-800-964-3262

Bedford, England  
+44 (0) 1234 350311

### Twiflex Limited

*Caliper Brakes and Thrusters*

Twickenham, England  
+44 (0) 20 8894 1161

### Industrial Clutch

*Pneumatic and Oil Immersed Clutches and Brakes*

Waukesha, WI - USA  
1-262-547-3357

## Gearing

### Boston Gear

*Enclosed and Open Gearing, Electrical and Mechanical P.T. Components*

Charlotte, NC - USA  
1-800-825-6544

*For application assistance:*  
1-800-816-5608

### Bauer Gear Motor

*Geared Motors*

Esslingen, Germany  
+49 (711) 3518 0

Somerset, NJ - USA  
1-732-469-8770

### Nuttall Gear and Delroyd Worm Gear

*Worm Gear and Helical Speed Reducers*

Niagara Falls, NY - USA  
1-716-298-4100

## Overrunning Clutches

### Formsprag Clutch

*Overrunning Clutches and Holdbacks*

Warren, MI - USA  
1-800-348-0881 – Press #1

*For application assistance:*  
1-800-348-0881 – Press #2

### Marland Clutch

*Roller Ramp and Sprag Type Overrunning Clutches and Backstops*

South Beloit, IL - USA  
1-800-216-3515

### Stieber Clutch

*Overrunning Clutches and Holdbacks*

Heidelberg, Germany  
+49 (0) 6221 30 47 0

## Belted Drives and Sheaves

### TB Wood's

*Belted Drives*

Chambersburg, PA - USA  
1-888-829-6637 – Press #5

*For application assistance:*  
1-888-829-6637 – Press #7

## Engineered Bearing Assemblies

### Kilian Manufacturing

*Engineered Bearing Assemblies*

Syracuse, NY - USA  
1-315-432-0700

For information concerning our sales offices in Asia Pacific check our website  
[www.altramotion.com.cn](http://www.altramotion.com.cn)



[www.warnerelectric.com](http://www.warnerelectric.com)

31 Industrial Park Road  
New Hartford, CT 06057 - USA  
815-389-3771  
Fax: 815-389-2582