

Pneumatic Clutches and Brakes

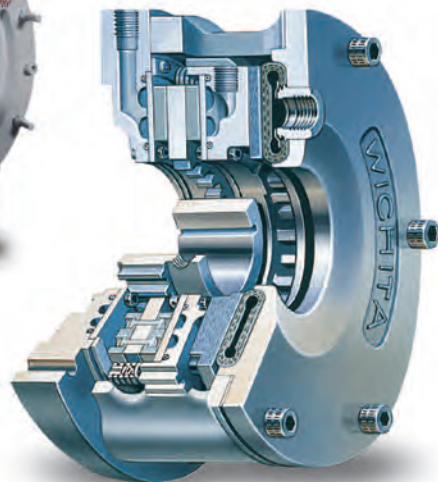

 **Wichita**[®]
Clutch

An Altra Industrial Motion Company

WALCO HCF TA A

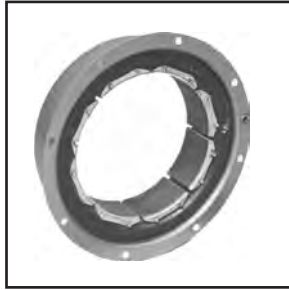

Drum Clutch/Brakes

- Ballmills
- Marine Drives

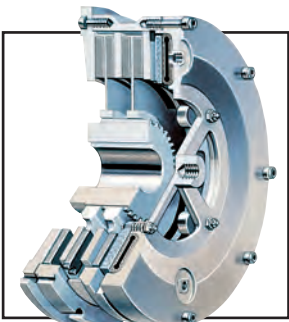

Low Inertia Clutches & Brakes

- Presses
- Conveyors
- Marine drives
- Shears
- Yarders
- Hoists

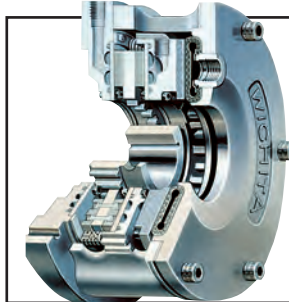

Kopper Kool Clutches & Brakes

- Unwinders
- Coilers
- Dynamometers
- Rewinds
- Yarders
- Winches

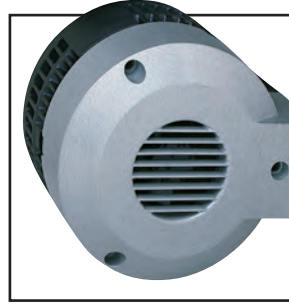

Mistral Brakes

- Corrugators
- Sheeters

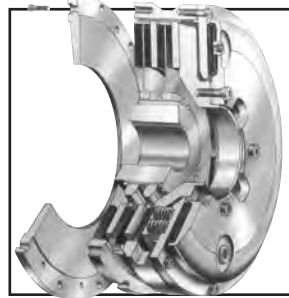

Spring Set Brakes

- Metal processing
- Mining

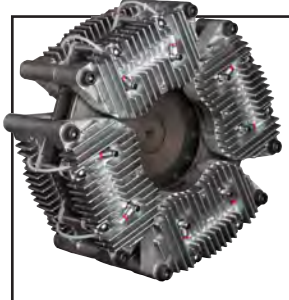

ModEvo

- General unwinds



HC Clutches and Brakes

- Marine Propulsion
- Winch Disconnects
- Conveyor/Mill soft starts



Standard Vent Clutches

- Ball mills
- Drilling rigs
- Grinding mills
- Shears
- Presses
- Yarders



AquaMaKKs Clutches & Brakes

- Drawworks
- Unwind stands
- Positioning and Mooring Winches

Dependable Torque Control Products

Wichita clutches and brakes provide the high speed acceleration and deceleration that are essential in modern process equipment. They are available in a variety of designs and mounting configurations and are used extensively around the world by leading OEM's in metal working, steel, pulp/paper, material handling, paper converting, marine, mining and energy.

Wichita provides custom designs to meet your particular application requirements, giving you the right solution to meet all your power transmission needs.

General Warnings



Do not repair clutches and brakes (with or without a guard) while they are rotating or with a load engaged.



Do not disassemble while air-tube is pressurized.



Heavy components should be handled carefully. If dropped they can cause serious bodily injury.



Caution, clutches and brakes generate heat. Allow cooling time before normal maintenance.



Do not exceed the recommended maximum air-pressure listed in the Specification Table for each type of unit.



Do not operate clutches and brakes without a guard.



Internal springs under compression. Please refer to installation and maintenance manuals for proper disassembly procedures.



Disable all power sources (electrical, pneumatic, mechanical, etc.) before servicing equipment.



Consult Wichita Installation and Maintenance manuals for proper disassembly and assembly procedures.



Wichita clutches and brakes are designed to be operated with original Wichita replacement parts. Using non-original replacement parts in Wichita clutches and/or brakes voids all warranties issued by Wichita Company Limited. Wichita also specifically disclaims any responsibility for damage to persons or property which may be related to the use of said brakes and clutches which employ non-original parts.

Contents

Customer Service	2
Parts and Service	4
Selection Guide	6
A Air Tube Disc Clutches and Brakes	10
Applications	11
Low Inertia & Very Low Inertia Clutches & Brakes	12
High Torque Clutches	30
Spring-Set Air Release Brakes	38
B Tension Brakes	46
Mistral Brakes	46
ModEvo Tension Brakes	48
C Standard Vent Clutches	50
Applications	51
Specifications	52
Driving Adaptors	53
D Drum Clutches and Brakes	58
DC Drum clutches and brakes	58
DCV Drum clutches and brakes	59
E HC Oil Immersed and HC Dry Clutches and Brakes	60
HC Oil Immersed	60
HC Dry	61
F Water Cooled Brakes	64
CSM (Kopper Kooled)	66
AquaMaKKs clutches and brakes	82

A

B

C

D

E

F

Customer Service

For over 50 years Wichita Clutch has provided engineered solutions to the most demanding torque control problems.

Founded in 1947, Wichita Clutch began manufacturing air-tube disc clutches and brakes. Today, we are recognized as a global leader in heavy-duty power transmission.

Total Support

Superior customer service is a common denominator at Wichita Clutch. It is this philosophy that places the needs of our customers at the central focus of our efforts. By implementing Cellular Manufacturing, Kan-Ban and Just-In-Time scheduling, our customers receive the products they require precisely when needed, and our computerized order entry systems allow quick and timely answers to your questions. An international distributor network puts local Wichita specialists only a phone call away.



Assured quality

Wichita is accredited to ISO 9001:2008 quality standards, and approved by the world's Ship Classification Societies. Wichita quality control doesn't end with manufacture though; our service and support continues long after installation with a help-line available 24 hours a day, every day of the year. Wichita also offers Genuine Wichita and Industrial Clutch parts and spares through our QuickServe facility, and on-site assistance from experienced engineers.



*Wichita Clutch Plant
Bedford, UK*



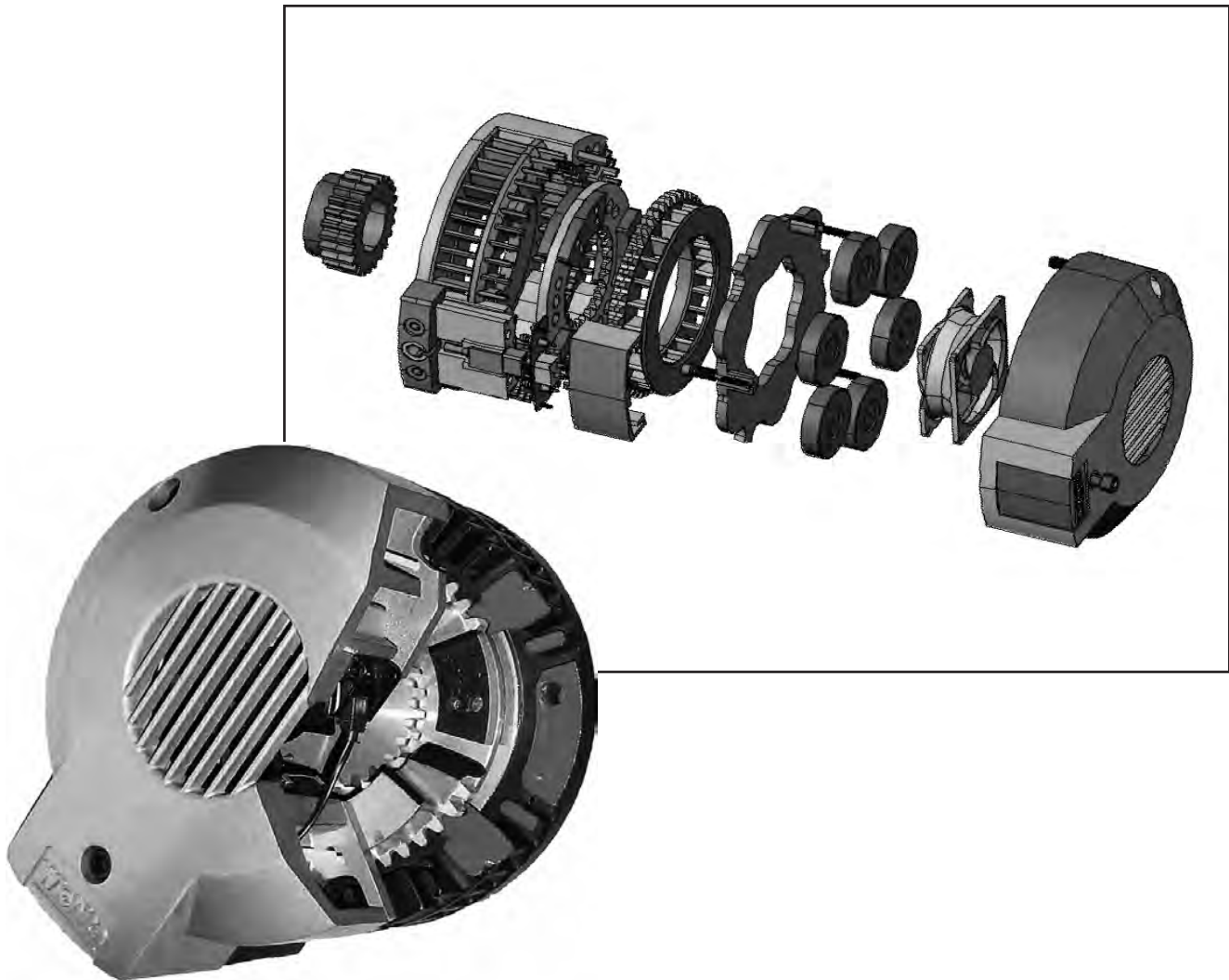

Engineering

Wichita has significant resources dedicated to the engineering disciplines required to design, manufacture and apply our heavy duty clutches and brakes. Our application engineers are able to provide timely response to your enquiries through our Computer Aided Product Selection (CAPS) system.

Wichita Design engineers utilize the latest 3D CAD systems in the design of new products, and dedication to emerging technologies has allowed us to solve the most challenging applications in heavy-duty power transmission.

From the simple air-tube disc clutch design that allows for greater torque capacity in multiple plate units to more complex bespoke solutions, years of engineering development have produced a variety of designs used extensively by leading OEM's in all major heavy duty applications.



Authorized distributors provide the wealth of knowledge and experience that can make the difference between getting your machine up and running without delay, and hours of downtime.

Your application benefits from Wichita research and development and quality control; consistency in material and quality gives longer life in friction discs and airtubes for replacement peace of mind.

Comparison Chart

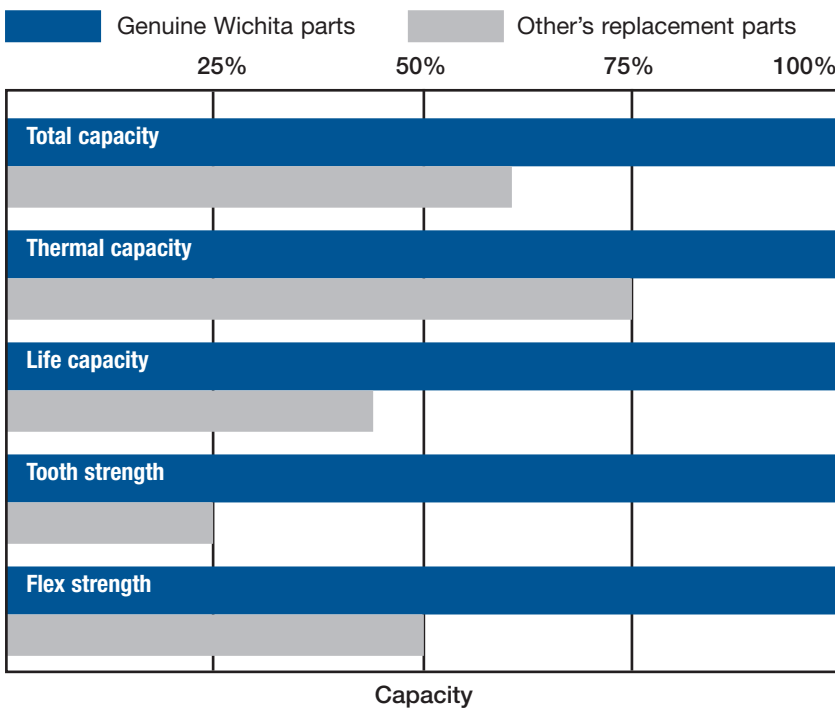

Genuine Wichita replacement parts

Features no one else can match!

Friction Discs

Special high strength proprietary materials with composite teeth offer the highest wear resistance whilst transmitting high output torque.

Due to continuous research and development and quality control, friction material provides longer life and more consistent operation.

- Friction discs exactly match the mating Wichita components for consistent and maximum high torque output.
- High strength for dependable, long life service.
- Higher heat resistance to combat unforeseen application problems.
- Consistent size for ease of replacement.
- Wear resistant polymers ensure compatibility with other Wichita parts.
- Air grooves to provide cooling and longer life.

Airtubes

Combination of space age fibers and elastomers give extended life and fit assurance. Wichita airtubes are trouble free and easy to replace.

- Controlled quality manufacture ensures long life and trouble free service.
- All genuine Wichita Airtubes are trade marked in mould.
- Consistent size allows ease of replacement if required.
- Low air volume construction reduces needless use of compressed air and reduces start/stop times.
- When used in combination with other Wichita parts, the Wichita airtube sustains its heat resistance to ensure long operating life in conditions unacceptable to other power transmission devices.

- Wichita split airtubes are available to replace full circle airtubes for emergency operation of important equipment.
- Wichita maintains a trade mark part number and serial number system moulded into the surface of Wichita airtubes for easy identification of genuine Wichita parts.

Quality Assurance

Continuous Process Improvements through Total Quality Commitment...Computer controlled machining equipment ensures precision tolerances for durability and consistent performance.

Technical Backup

Comprehensive technical information published on all our products is available to our customers, including complete dimensional drawings, performance curves, exploded part drawings, helpful application engineering data, and complete service/ installation manuals. Using genuine Wichita parts assures you of the most knowledgeable technical support in the industry.

Available Now!

A network of service oriented, technically trained, authorized Wichita distributors will promptly serve your replacement part needs.



HBS 42 brake assembly

Your Wichita Distributor

Your Wichita distributor is a power transmission specialist.

Because they're your distributor, they have an understanding of your total power transmission system needs. Since they represent Wichita, they can put together the best possible system from the very best components to satisfy your requirements.

Your Wichita distributor, backed by factory regional sales engineers, is near enough to visit your plant to see your problems first hand. They're big enough to find the parts you need on their own shelves, eliminating the time lost while a part is shipped direct. They're experienced enough to make sure the parts he sells are right and perform as promised.

Your Wichita distributor represents your needs to his suppliers. Their first commitment is to keep your plant in operation...getting it back in operation as quickly as possible after trouble strikes...maximizing your productivity.

Your Wichita distributor is just as important to Wichita as they are to you. That's why we put a great deal of emphasis on training. Their "on-the-spot" knowledge is our assurance that you'll benefit in your plant from all the performance features we build into our products.

The Wichita difference... local availability

Friction discs and airtubes are available off-the-shelf from Wichita distributors throughout Europe, Asia Pacific and the USA. Wichita distributors are power transmission specialists offering local stock, local service and local on-the-spot application assistance.

Selection Guide

Application Factors

Determine the best Wichita clutch or brake for your application by making a preliminary product selection.

1. Decide which of the four possible functions you wish to perform.
2. Choose the mounting arrangement best suited to your application.
3. In the Function/Mounting chart below, choose the proper type of mounting (1,2,3, etc.)
4. Consult your Wichita representative for final product selection.

Wichita Product	Page No.	Function/Mounting Condition				
		Controlled Acceleration Provide smooth acceleration of a load.	Cycling Accurately positions a load in a repeatable fashion.	Controlled Deceleration Provides a smooth, cushioned deceleration of a load.	Controlled Slip Provide continuous tension to a web or strand.	
					High Heat	Low Heat
Drum Clutch/Brake	78	1, 2	1, 2	1, 2, 3		1, 2
Very Low Inertia Clutch or Brake	12	1, 2	1, 2	1, 2, 3		1, 2, 3
Low Inertia Clutch or Brake	12	1, 2	1, 2	1, 2, 3		1, 2
High Torque Clutch	30		1	1		1
Spring-Set Air Release Brake	38		1, 2, 3	1, 2, 3		
CSM (Kopper Kool) Clutch or Brake	46	1, 2, 3	1, 2, 3	1, 2, 3	1, 2, 3	
Mistral Brake (Tension Brakes)	66					2
ModEvo (Tension Brakes)	68					2, 3
AquaMaKKs Clutches and Brakes (Water Cooled)	86			2, 5		
Standard Vent Coupling Clutch	71	3, 4				
Standard Vent Grinding Mill Clutch	71	3, 4				
Oil Immersed and Dry HC	80	3, 4		3, 4		

Types of Mounting (see page 7)

- | | |
|------------------|-------------------------------|
| 1 Indirect Mount | 4 Shaft-to-Shaft |
| 2 Direct Mount | 5 Brake Mount Electric |
| 3 Through Shaft | 6 Clutch or Brake Mount Press |

Types of mounting

1 Indirect Mount

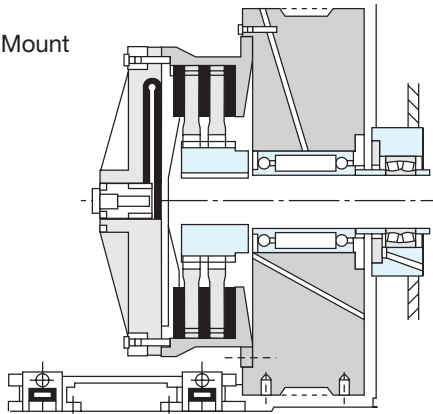

2 Direct Mount

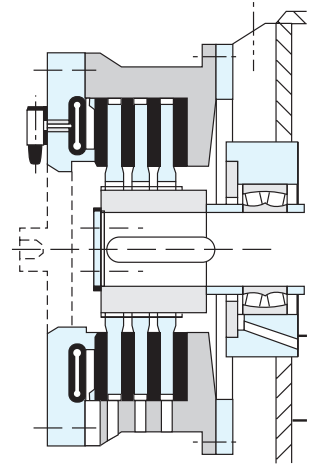

3 Through Shaft, Inboard Mount Clutch

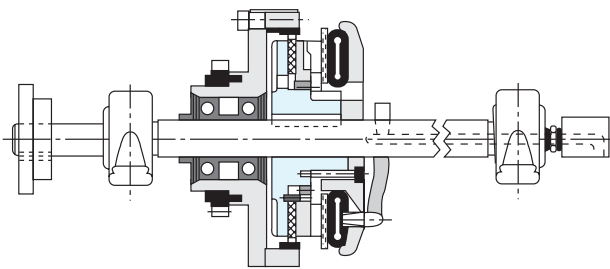

4 Shaft-to-Shaft In-line (clutch-coupling)

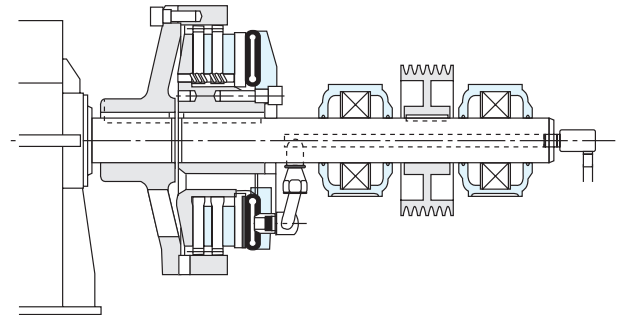

5 Electric Motor C-Face or Foot Mount Brake

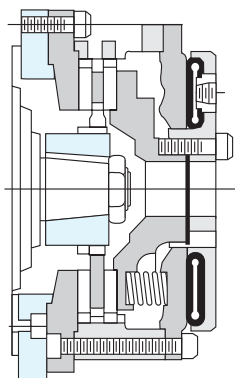

6 Typical Wichita Clutch and Brake Mounting on a Press

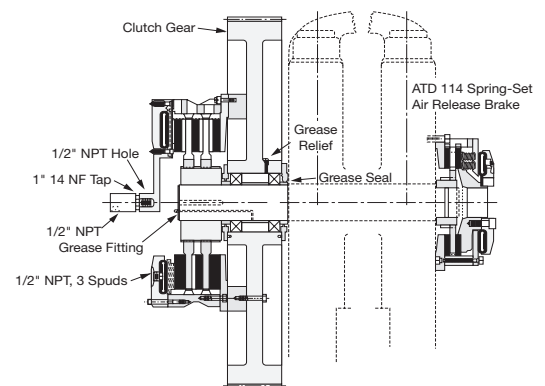

Selection Guide

Application Factors

Clutch/Brake sizes are affected by the following variables:

1. Machines that operate under smooth loads require smaller clutch/brakes. These machines are driven by either multi-cylinder high speed engines or electric motors with reduced starting current.
2. Drives that require high starting current motors will require clutch/brakes with sufficient torque to prevent excessive slipping while starting.
3. Starting torque may be high, which requires a fast clutch/brake response time to transmit the required torque; or, extended clutch/brake slip time is required to protect the prime mover.
4. Starting torques may be very low compared to the normal torque which may result in the clutch/brake not being fully pressurized prior to the time of torque requirement. This will cause the clutch/brake to over heat from slippage. Clutch/brake inflation time in this instance is very important.
5. Clutch/brakes on most machines are designed to slip prior to damage from shockloads. As a result, the clutch/brake may require periodic maintenance; therefore the clutch/brake should be located in the power train for easy access. Clutch/brakes should also be located for maximum cooling air. In instances where this is not possible, forced air cooling may be desirable to extend clutch/brake life.
6. Safe operating speeds for clutch/brakes should be maintained in-design. The following material specifications are recommended for safe operation. The maximum speeds shown are safe operating speeds based upon years of Wichita experience. Consult Wichita for higher speed versions.

Maximum Clutch/Brake Contact Velocity m/sec	Material
30m/sec (Recommended upper limit for slip)	cast iron
45m/sec.	ductile iron
60m/sec.	steel

Dynamic balancing recommended when peripheral speeds exceed 18 m/sec. These velocities are measured at the nominal outside diameter of the clutch/brake plate.

Field of Application	Machine or Equipment	Wichita Product												
		Drum C/B	Air Tube Disc Clutches & Brakes				CSM (KK)	Tension Brakes		Spring-Set Motor Brakes	Standard Vent Clutches		Oil Immersed and Dry HC	AquaMakks
			Very Low Inertia	Low Inertia	High Torque	Spring-Set		Mistral	ModEvo		Coupling	Ball Mill		
Air Movement Pumps	Centrifugal compressors	•		•	•						•			
	Reciprocating compressors (over 2 cylinders)	•		•	•						•			
	Reciprocating compressors (1 or 2 cylinders)	•		•	•						•			
	Centrifugal fans Blowers	•		•	•						•			
Agitators	Liquid Semi-solid Solids	•		•	•						•			
Brick manufacturing	Brick press	•	•	•		•					•			
	Extruder Pug mill	•		•	•						•			
Canning & bottling machine	Bottle-can feeders	•	•	•	•									
	Filling Mixers	•		•	•						•			

Selection Guide

Field of Application	Machine or Equipment	Wichita Product												
		Drum C/B	Air Tube Disc Clutches & Brakes				CSM (KK)	Tension Brakes		Spring-Set Motor Brakes	Standard Vent Clutches		Oil Immersed and Dry HC	AquaMaKks
			Very Low Inertia	Low Inertia	High Torque	Spring-Set		Mistral	ModEvo		Coupling	Ball Mill		
Engine driven equipment	Crane	•		•		•				•	•			•
	Hoist	•		•		•					•			•
	Engine												•	
	Crowd	•		•							•			
Grinding mills	Ball-rod-sag-pebble												•	
	Crushers												•	
	Shakers												•	
Lumber processing	Yarder	•	•	•	•	•								
	Carriages, conveyers Chipper, logger	•	•	•	•	•								
Marine	Propulsion clutch CP wheel	•		•									•	
	Shaft brakes	•		•									•	
	Propulsion reversing type	•		•									•	
	Anchor winch	•		•		•							•	•
Bulk material handling	Conveyors evenly loaded	•		•	•	•							•	
	Line shaft evenly loaded	•		•	•	•							•	
	Feeders	•		•	•	•							•	
	Elevators	•		•	•	•							•	
Metal production & metalforming	Coilers	•	•	•		•							•	
	Slitters	•	•	•	•	•							•	
	Press brake	•	•	•	•	•							•	
	Non-geared press	•	•	•	•	•							•	
	Geared press	•	•	•	•	•							•	
	Draw bench	•	•	•		•							•	
	Rolling mill	•	•	•									•	
	Shear	•	•	•	•	•							•	
	Back geared press	•	•	•	•	•							•	
	Hammer Mill	•		•		•				•				
	Forging	•		•		•					•			
Paper industry dryer sections & calenders, consult factory	Fourdrinier to 500 FPM													
	Fourdrinier to 1800 RPM													
	Paper mill plane													
	Smoothing press	•		•		•		•	•				•	
	Press selections													
	Dryers Calenders													
Petroleum production	Drilling & service rig	•		•		•							•	
	Master clutches	•		•									•	
	Compound clutches	•		•									•	
	Rotary Drum	•		•									•	
	Mud pumps	•											•	•
	PTO clutches												•	
Rubber manufacturing	Transfer machines evenly loaded													
	Banberry mixer													
	Drum mixer	•		•									•	
	Extruder													
	Calender													
	Centrifuge													

Air Tube Disc Clutches and Brakes

Typical Applications

Wichita Spring Set brakes provide reliable holding and emergency stop duties on drawwork applications.

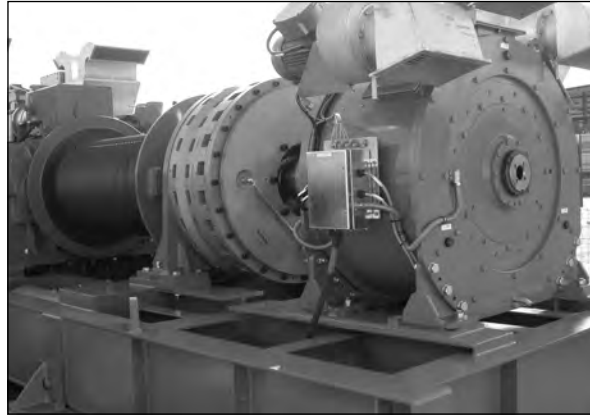

Wichita Spring-Set Air Release Brakes ensure accuracy and high performance for a metal shear.



Wichita Marine Low Inertia Clutches on a three speed dredge pump drive gearbox

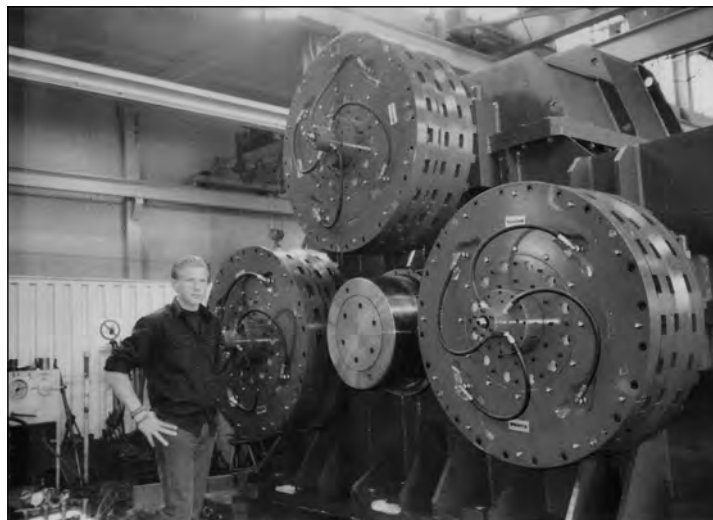

Application Guidelines

This chart gives application factors ranging from light duty (group A) to extra heavy duty (group D).

Field of Application	Group A	Group B	Group C	Group D
Pumps		Centrifugal compressors	Reciprocating compressors over 2 cylinders, centrifugal fans & blowers	Reciprocating compressors one or two cylinders
Agitators	Liquid	Semi-solid	Solids	
Brick manufacturing			Brick press, extruder, pug mill	
Canning & bottling machine		Bottle-can feeders, filling, mixers		
Engine driven equipment			Crane, hoist, engine	Crowd
Grinding mills			Ball-rod-sag-pebble	Crushers, shakers
Lumber processing		Yarder	Carriages, conveyers	Chipper, logger
Marine		Propulsion clutch, anchor winch	Shaft brakes, propulsion reversing type	
Bulk material handling	Conveyors evenly loaded, line shaft evenly loaded	Feeders	Elevators	
Metal production & metalforming		Coilers, slitters, press brake, non-g geared press, geared press	Draw bench, rolling mill, shear, back geared press, deep draw press, transfer press, toggle press	Hammer mill, forming press, forging press, header press, knuckle press
Paper industry dryer sections & calenders Consult factory			Fourdrinier to 500 FPM, paper mill plane & smoothing press	Fourdrinier to 1800 RPM press selections, calenders & dryers
Petroleum production		Drilling & service rig master clutches, compound clutches, rotary, drum		Mud pumps, PTO clutches
Rubber manufacturing	Transfer machines evenly loaded		Banberry mixer, drum mixer, extruder, calender	Centrifuge

Air Tube Disc Clutches and Brakes

Low Inertia and Very Low Inertia Clutches and Brakes

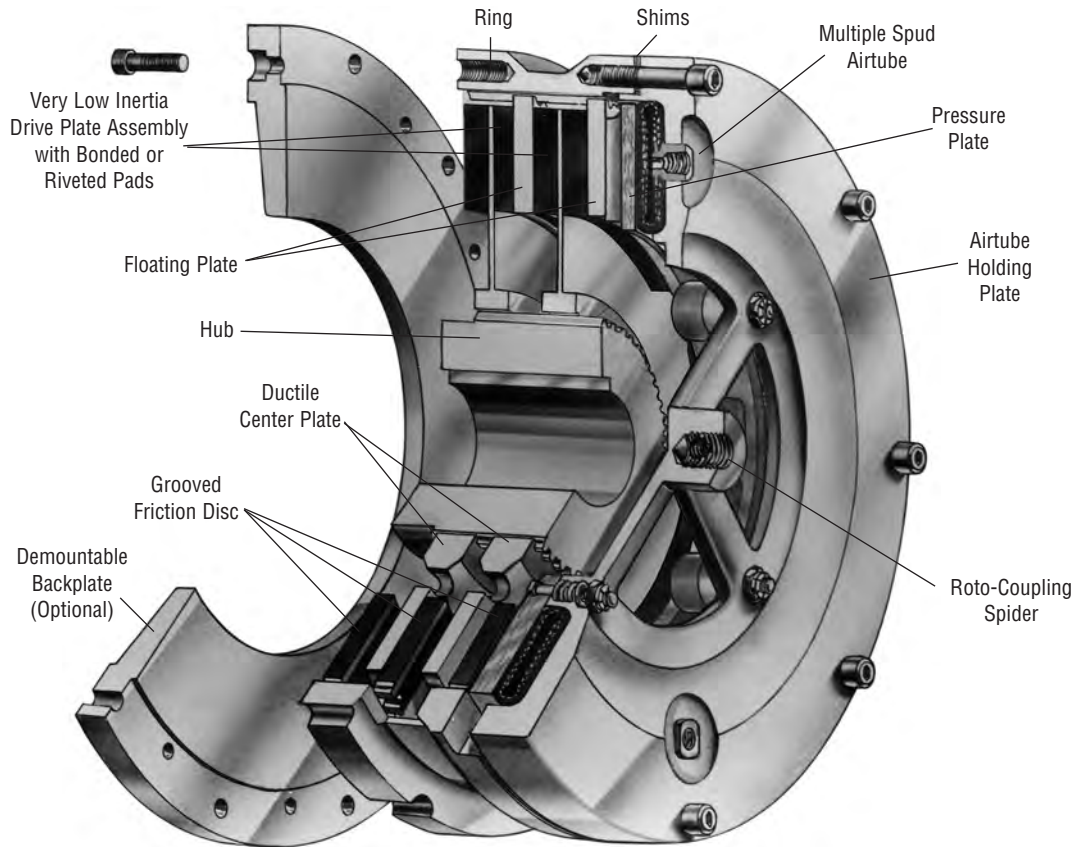

Operating Features

The Wichita Air-Tube Disc Clutch combines all the best features of the disc type clutch with all the advantages of direct air engagement. The simplest and most trouble-free method of applying air pressure is through direct axial pressure application by compressed air in a special composition full-circle tube.

Wichita Clutches engage smoothly without noise, shock or impact and release completely in a fraction of a second. Extremely fast action is possible because of the small volume of air required.

Clutches may be slipped moderately to control the acceleration rate.

When large inertia loads are powered from electric motors, smooth, controlled slip starts by Wichita Clutches can keep power demands below the allowed maximum.

Heat generated by controlled slipping or high cycle rate operation is dissipated by the centrifugal blower design of these units.

Wichita Low Inertia and Very Low Inertia Clutches and Brakes are designed to be completely free from effects of centrifugal force and self energization.

Torque developed is in direct proportion to air pressure applied.

These clutches and brakes interface well with automated controls through simple air and/or electric circuits.

Water cooled, copper disc clutches are available for use when power transmission needs require excessive or constant slipping which demands higher heat dissipation.

Wichita Clutches operate perfectly when teamed with Wichita Brakes in production situations requiring tension control, cyclic duty, or positioning.

Wichita Brakes have the same outstanding performance characteristics as Wichita Clutches.

Selection Requirements

The selection of a Low Inertia Brake is based on:

1. Torque required to stop a load.
2. Friction area necessary to absorb rotational energy.
3. Contact velocity of rotating discs.
4. Maximum bore capacity of unit.

Selection example

To properly select a Low Inertia Brake for a controlled deceleration application, the following information is needed:

Speed 750 RPM
 Shaft Dia. 127mm
 Inertia to Stop 104 kg.m²
 Stop Time 5 sec.
 Air Pressure Available 5.5 bar

Calculations

$$\begin{aligned} \text{Avg. kW} &= \frac{J \times (\text{RPM})^2}{1.82 \times 10^5 \times \text{Stop Time}} \\ &= \frac{104 \times (750)^2}{1.82 \times 10^5 \times 5 \text{ sec.}} = 65 \text{ kW} \end{aligned}$$

$$\begin{aligned} \text{Torque} &= \frac{J \times \text{RPM}}{9.55 \times \text{Stop Time}} \\ &= 1634 \text{ Nm} \end{aligned}$$

Using the above calculations, consult the Low Inertia Specifications Chart on pages 14 and 15.

Summary

As calculated, the torque required to stop the load in 5 seconds is 1634 Nm. Wichita Low Inertia Brakes are rated at 5.5 bar.

Consult pages 14 and 22 for clutch and brake specifications. A Low Inertia model 114 Brake produces 2435 Nm x 0.75 = 1826Nm selection torque at 5.5 bar. However, the bore capacity is 4.125 inches. This application requires a 5 inch bore. Therefore, a Low Inertia 118 is to be investigated.

Catalog Torque Rating	=	5705 Nm @ 5.5 bar
Selection Torque Rating	=	5705 x 0.75
	=	4278 Nm
Maximum Bore Capacity	=	13.3 cm.

All of these ratings are acceptable for the given application data.

Next, check contact velocity of rotating discs.

$$\begin{aligned} &= \frac{\text{Diameter of centerplate (metre)} \times \text{RPM}}{19.1} \\ &= \frac{457 \times 750}{19.1} \\ &= 17.95 \text{ M/sec} \end{aligned}$$

Standard material is sufficient up to 30 M/sec (see page 11). Balancing is recommended above 18 M/sec.

Therefore, a Low Inertia ATD-118 brake is the optimum choice for this application.

Note:

This application example is for preliminary sizing only. Contact a Wichita Sales Engineer or the factory for final selection.



Air Tube Disc Clutches and Brakes

Low Inertia Clutches

Specifications

Model Size ATD-	Slip Torque Capacity Nm		Duty Factors HP/100 RPM				Max. Bore Rect. Key mm
	5.5 BAR	7 BAR	A	B	C	D	
LIM 104	57	72	—	—	—	—	25
LIM 106	340	435	6.2	4.4	2.2	1.1	50
LIM 206	680	870	12.5	8.8	4.4	2.2	
LIM 108	620	790	11.1	8	4	2	
LIM 208	1240	1580	22.2	16	8	4	57
LIM 308	1865	2375	33.3	24	12	6	
LIM 111	1400	1785	25	18	9	5	
LIM 211	2800	3570	50	36	18	10	64
LIM 311	4235	5390	75	54	27	15	
LIM 114	2435	3100	44	31	16	8	
LIM 214	4870	6200	88	62	32	16	89
LIM 314	7355	9365	132	93	48	24	
LIM 116	3360	4275	60	46	24	12	
LIM 216	6720	8550	120	92	48	24	102
LIM 316	10080	12825	180	139	72	36	
LIM 118	5705	7260	102	75	35	21	
LIM 218	11410	14520	204	150	70	42	121
LIM 218	17115	21780	306	225	105	63	
LIM 121	7755	9870	139	107	55	28	
LIM 221	15510	19740	277	213	111	55	152
LIM 321	23265	29610	416	320	166	83	
LIM 124H	13575	17275	243	180	90	40	
LIM 224H	27150	34550	487	360	180	80	152
LIM 324H	40725	51825	729	540	270	120	
LIM 127	15260	19420	273	210	109	55	
LIM 227	30520	38840	546	420	218	109	165
LIM 327	45780	58260	819	630	327	164	
LIM 130H	29630	37710	519	380	190	100	
LIM 230H	59260	75420	1038	760	380	200	184
LIM 330H	88890	113130	1557	1140	570	300	
LIM 136	44920	57175	805	600	295	165	
LIM 236	89840	114350	1610	1200	590	330	229
LIM 336	134760	171525	2415	1800	885	495	
LIM 142	69160	81660	1150	850	425	235	
LIM 242	128320	163320	2300	1700	850	470	355
LIM 342	192480	244980	3450	2550	1275	705	
LIM 148	118800	151200	2225	1600	800	455	
LIM 248	237600	302400	4450	3200	1600	915	455
LIM 348	356400	453600	6675	4800	2400	1365	
LIM 260	473000	602000	9440	5950	3470	1940	
LIM 360	709000	902300	14160	8925	5205	2910	480
LIM 460	946000	1204000	18880	11900	6940	3880	

Maximum operating pressure is 8.5 BAR non cyclic / 7 BAR cyclic

Air Tube Disc Clutches and Brakes

A

Model Size ATD-	Balance Speed RPM	Airtube Type		Airtube Volume cm ³		Wt. kg	Total Clutch J=mr ² kgm ²	Hub & Center Plate	
		Reg-Speed RPM	High Speed RPM*	New	Worn			Wt. kg	J=mr ² kgm ²
LIM 104	NA	1800	2600*	2.3	8.6	7	0.032	0.7	0.001
LIM 106	2225	1800	2600*	30	195	12	0.105	2.9	0.010
LIM 206						18	0.139	5.5	0.019
LIM 108				56	300	28	0.315	5.0	0.023
LIM 208	1675	1750	3000*			32	0.357	8.6	0.042
LIM 308						42	4.174	12.7	0.084
LIM 111				90	500	60	1.14	10.4	0.097
LIM 211	1200	1400	2800*			77	1.43	20.4	0.190
LIM 311						94	2.19	54.9	0.295
LIM 114				125	700	83	2.36	20.9	0.240
LIM 214	950	1200	2200*			106	2.95	34.9	0.464
LIM 314						132	3.37	54.9	0.704
LIM 116				161	919	117	4.34	26.8	0.430
LIM 216	835	1200	2000*			148	5.27	48.1	0.826
LIM 316						162	5.27	68.5	1.248
LIM 118				251	1400	141	6.66	33.1	0.632
LIM 218	950	1000	2000*			171	7.72	54.4	1.214
LIM 218						214	9.23	81.6	1.821
LIM 121				300	1599	212	12.77	52.6	1.35
LIM 221	650	900	1650*			264	15.01	89.8	2.57
LIM 321						331	18.97	123.4	3.88
LIM 124H				490	2606	289	19.73	60.0	2.4
LIM 224H	550	700	1400*			376	26.05	117.9	4.6
LIM 324H						465	31.00	172.0	6.8
LIM 127				490	2606	349	29.8	84.8	4.1
LIM 227	500	700	1400*			431	36.3	146.1	8.1
LIM 327						504	40.9	251.7	12.0
LIM 130H				960	5096	469	49.3	135.2	8.0
LIM 230H	450	600	1100*			640	65.4	247.7	15.6
LIM 330H						794	75.4	367.4	20.1
LIM 136				1803	6801	660	99.8	209.1	15.7
LIM 236	375	600	900*			904	136.9	321.1	30.6
LIM 336						1184	171.0	514.4	46.0
LIM 142				2098	7997	892	199	308	30
LIM 242	325	500	800*			1239	242	543	58
LIM 342						1680	387	601	76
LIM 148				3550	13500	1432	393	499	75
LIM 248	275	400	700*			2132	581	881	141
LIM 348						2966	759	1338	208
LIM 260				8407	29000	4288	2055	1164	298
LIM 360	225	320	550*			5281	2415	1755	448
LIM 460						6577	2908	2585	635

* Consult Factory for Special Assembly Number.

Air Tube Disc Clutches and Brakes

Low Inertia Clutches (Sizes 8-36)

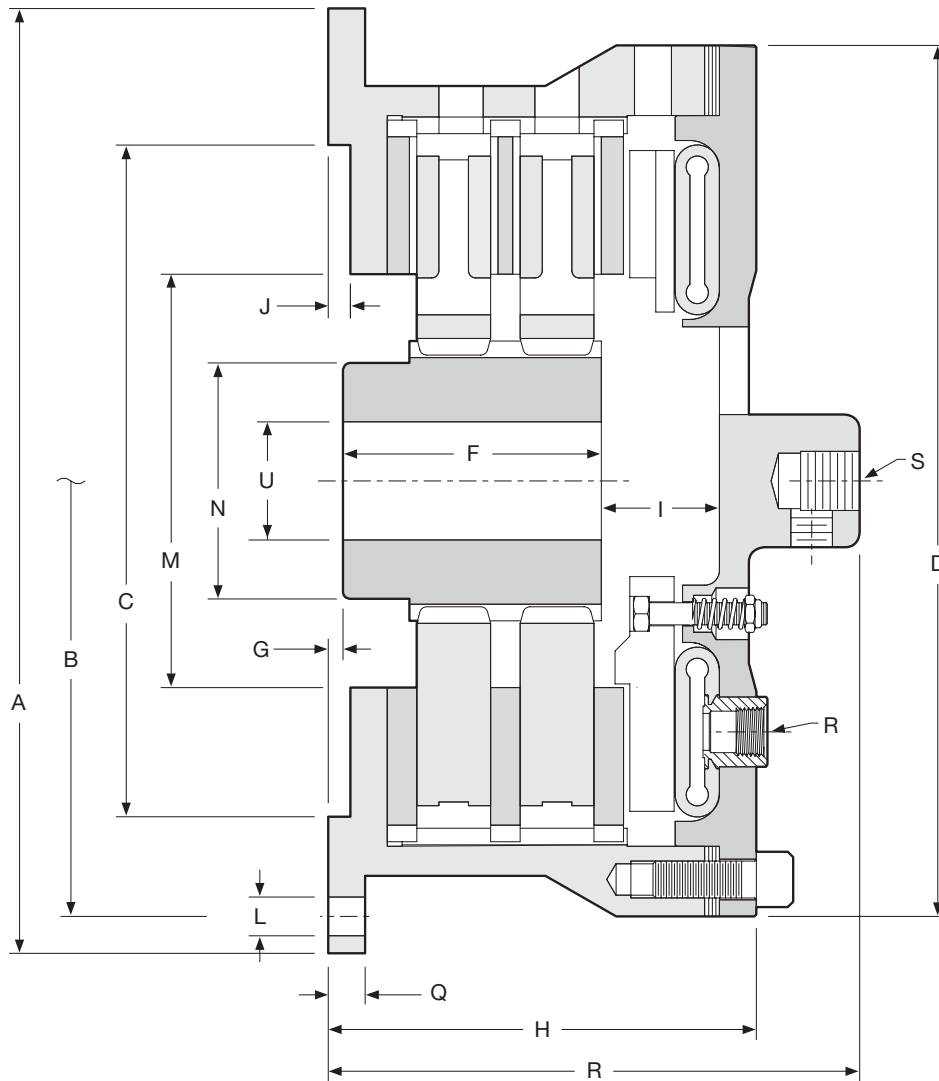

Air Tube Disc Clutches and Brakes



Dimensions: mm

Model Size ATD-	A	B Hole Circle	C ⁽¹⁾	D	E	F	G	H
LIM 108					160.3	50.8	6.4	115.8
LIM 208	308.1	280	220	282.7	195.3	82.6	7.9	150.9
LIM 111					184.2	69.9	3.3	139.7
LIM 211	406.4	375	295	374.7	228.6	111.3	6.4	184.2
LIM 114					192.0	95.3	3.3	153.9
LIM 214	476.3	445	370	444.5	238.3	114.3	9.7	200.2
LIM 116					198.4	101.6	9.7	160.3
LIM 216	539.8	510	410	508.0	247.7	120.7	9.7	209.6
LIM 316					296.9	168.4	9.7	258.8
LIM 118					208.0	101.6	11.2	169.9
LIM 218	590.6	560	470	558.8	257.3	120.7	11.2	219.2
LIM 318					308.1	165.1	11.2	270.0
LIM 121					225.6	101.6	19.1	187.5
LIM 221	685.8	648	540	632.0	277.9	130.3	16.0	239.8
LIM 321					336.6	181.1	19.1	298.5
LIM 124H					231.9	101.6	17.5	193.8
LIM 224H	762	730	620	736.6	289.1	130.3	19.1	251.0
LIM 324H					349.3	190.5	19.1	311.2
LIM 127					238.3	114.3	19.1	200.2
LIM 227	831.9	800	700	787.4	301.8	174.8	19.1	263.7
LIM 327					—	—	—	—
LIM 130H					317.5	127.0	16.0	209.6
LIM 230H	939.8	900	775	882.7	404.8	181.1	47.8	296.9
LIM 330H					—	—	—	—
LIM 136					328.7	143.0	16.0	239.8
LIM 236	1104.9	1065	925	1041.4	422.4	228.6	16.0	323.9
LIM 336					505.0	314.5	16.0	416.1

⁽¹⁾ Dimension "C" is given as a nominal figure. The applicable tolerance is ISO H7. (Consult factory for drawing before final layout.)

Dimensions: mm

Model Size ATD-	I	J	L	M	N	Q	R	S	U	
			No. - Size				No. - Size		Min.	Max.
LIM 108	45.2		6 x Ø14				2 - 1/2 NPT	1"-14NF	25	50.8
LIM 208	47.8	6.4	6 x Ø14	136.7	88.9	12.7	2 - 1/2 NPT	1"-14NF	25	63.5
LIM 111	50.8	9.7	6 x Ø18	177.8	101.6	16.0	2 - 1/2 NPT	1"-14NF	25	63.5
LIM 211	50.8	9.7	6 x Ø18	177.8	101.6	16.0	2 - 1/2 NPT	1"-14NF	25	63.5
LIM 114	36.6		8 x Ø18				2 - 1/2 NPT	1"-14NF	35.1	88.9
LIM 214	54.1	9.7	8 x Ø18	239.8	139.7	16.0	2 - 1/2 NPT	1"-14NF	35.1	88.9
LIM 116	28.7		12 x Ø18				2 - 1/2 NPT	1"-14NF	35.1	101.6
LIM 216	58.7	9.7	12 x Ø18	266.7	152.4	16.0	2 - 1/2 NPT	1"-14NF	35.1	101.6
LIM 316	58.7		12 x Ø18				2 - 1/2 NPT	1"-14NF	35.1	101.6
LIM 118	31.8		12 x Ø18				3 - 1/2 NPT	1"-14NF	50.8	120.7
LIM 218	63.5	9.7	12 x Ø18	317.5	177.8	16.0	3 - 1/2 NPT	1"-14NF	50.8	120.7
LIM 318	69.9		12 x Ø18				3 - 1/2 NPT	1"-14NF	50.8	120.7
LIM 121	41.4		12 x Ø18				3 - 1/2 NPT	1"-14NF	50.8	152.4
LIM 221	68.1	7.9	12 x Ø18	368.3	228.6	19.1	3 - 1/2 NPT	1"-14NF	50.8	152.4
LIM 321	69.9		12 x Ø18				3 - 1/2 NPT	1"-14NF	50.8	152.4
LIM 124H	44.5		12 x Ø18				3 - 1/2 NPT	1"-14NF	50.8	152.4
LIM 224H	74.7	6.4	12 x Ø18	368.3	228.6	19.1	3 - 1/2 NPT	1"-14NF	50.8	152.4
LIM 324H	73.2		12 x Ø18				3 - 1/2 NPT	1"-14NF	50.8	152.4
LIM 127	35.1		16 x Ø18				3 - 1/2 NPT	1"-14NF	63.5	165.1
LIM 227	38.1	6.4	16 x Ø18	412.8	228.6	19.1	3 - 1/2 NPT	1"-14NF	63.5	165.1
LIM 327	—	—	16 x Ø18				3 - 1/2 NPT	1"-14NF	63.5	165.1
LIM 130H	46.0		18 x Ø22				4 - 1/2 NPT	1" NPT	63.5	184.2
LIM 230H	47.8	6.4	18 x Ø22	489	254	19.1	4 - 1/2 NPT	1" NPT	63.5	184.2
LIM 330H	—		18 x Ø22				4 - 1/2 NPT	1" NPT	63.5	184.2
LIM 136	35.1		18 x Ø22				4 - 1/2 NPT	1" NPT	152.4	228.6
LIM 236	41.4	6.4	18 x Ø22	600.2	304.8	22.4	4 - 1/2 NPT	1" NPT	152.4	228.6
LIM 336	44.5		18 x Ø22				4 - 1/2 NPT	1" NPT	152.4	228.6

(Consult factory for drawing before final layout.)

Air Tube Disc Clutches and Brakes

Low Inertia Clutches (Size 6, 42-60)

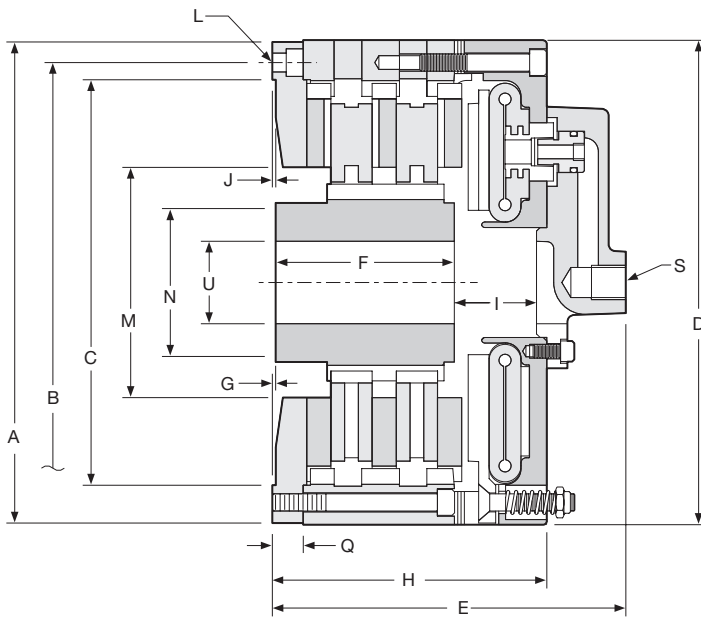

Size 6

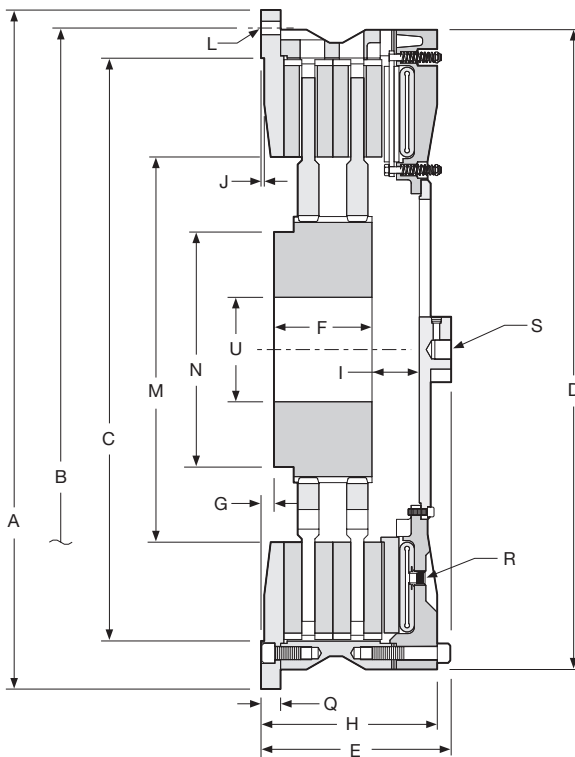

Size 42-60

Air Tube Disc Clutches and Brakes



Dimensions: mm

Model Size ATD-	A	B Hole Circle	C ⁽¹⁾	D	E	F	G	H
LIM 104	180	165	140	184	111	22	20	79.0
LIM 106					131.8	50.8	0.0	95.3
LIM 206	222.3	203.20	190	223.8	163.3	82.6	1.5	127.0
LIM 142					274.6	143.0	25.40	247.7
LIM 242	1320.8	1250.95	1134	1244.6	369.8	190.5		342.9
LIM 148					373.1	152.4	0.0	271.5
LIM 248	1549.4	1473.20	1320	1441.5	484.4	222.3	25.4	382.8
LIM 260 ⁽¹⁾					515.6	238.3	6.4	456.9
LIM 360 ⁽¹⁾	1790.7	1689.10	1590	1790.7	558.8	311.2	0.0	498.6
LIM 460 ⁽¹⁾					717.6	473.2	6.4	689.1

⁽¹⁾ Dimension "C" is given as a nominal figure. The applicable tolerance is ISO H7.
(Consult factory for drawing before final layout.)

Dimensions: mm

Model Size ATD-	I	J	L	M	N	Q	R	S	U	
			No. - Size				No. - Size		Min.	Max.
LIM 104	17.5	4	4 x Ø8.5	76	45	11	2 - 1/8 NPT	5/8"-18NF	15.2	25.4
LIM 106	39.6									
LIM 206	38.1	1.5	4 x Ø9	106.4	68.3	14.2	—	5/8"-11NF	15.2	50.8
LIM 142	44.5									
LIM 242	92.2	6.4	24 x Ø26	749.3	457.2	38.1	4 - 1/2 NPT	1.5"-12NF	203.2	355.6
LIM 148	93.7									
LIM 248	109.7	6.4	24 x M24	812.8	654.1	38.1	4 - 1/2 NPT	1" NPT	254.0	457.2
LIM 260 ⁽¹⁾	156.7									
LIM 360 ⁽¹⁾	131.8	6.4	24 - 2"NC	914.4	685.8	—	6 - 1/2 NPT	2"-12NF	279.4	482.6
LIM 460 ⁽¹⁾	162.1									

⁽¹⁾Less backplate.
(Consult factory for drawing before final layout.)

Air Tube Disc Clutches and Brakes

Low Inertia Clutch Air Hose Kits

Hoses from the airtube inlets (spuds) are connected to the central adaptor (spider) on the clutch into which screws the roto coupling. For cycling duties and fastest response, silenced quick exhaust valves (SQEV's) should be used. Note, however (a) quick exhaust valves without silencers (QEV's) can be used where noise is not a problem. (b) QEV's cannot be fitted to models 104 to 206. For other duties elbows are supplied.

For models 106 to 208, 1 hose is adequate for low speeds. Use 2 hoses for high speeds.

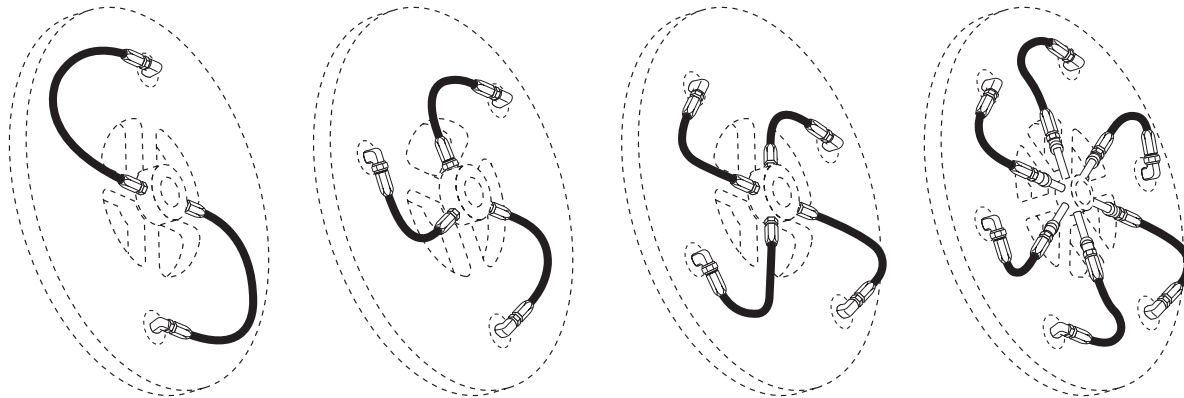

Roto-couplings

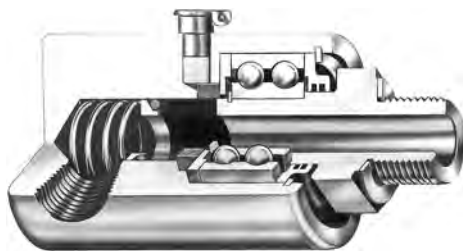

The Wichita Roto-coupling is a device to connect, or couple, a non-rotating air, gas, or fluid line to a rotating shaft.

Quick Exhaust Valve

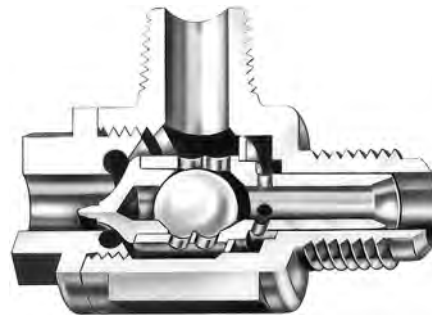

The Wichita Springless Quick Exhaust Valve discharges twice as fast as any other valve tested in our laboratory and is four to five times faster than some common makes of valves.

This valve will close and seal with less than 1.5 BAR. Most others require 1.7 to 2 BAR to definitely seal. In actual tests, the Wichita Valve made many hundreds of thousands of engagements and disengagements before the slightest leak occurred, or any parts needed replacement. Other valves which were tested required major replacement in fewer than 20,000 cycles.



Air Tube Disc Clutches and Brakes

A

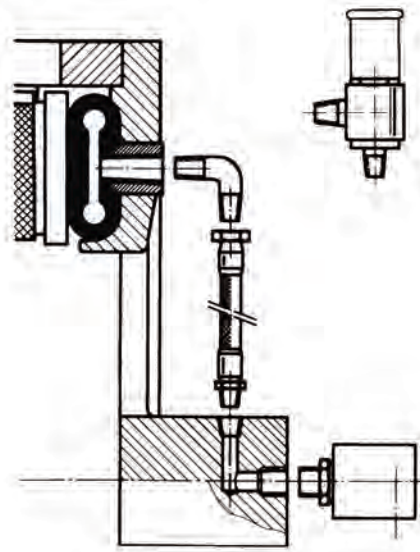

Quick Exhaust valve (QEV 40061-010/040) with silencer (SQEV 40061-510/540)

1/4" ROTO COUPLING PART NO. 40067-730

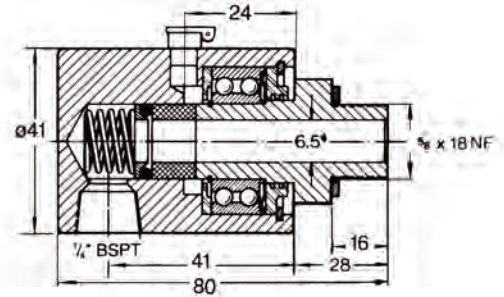

1/2" ROTO COUPLING PART NO. 40067-740

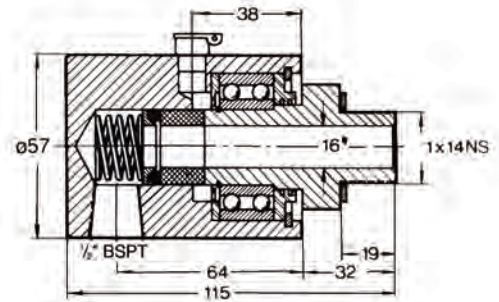

1" ROTO COUPLING PART NO. 24181-040

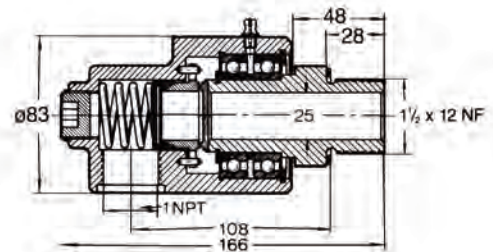

Air Set Coding Example: **Air Set No. 333 - 18 RSQ**

Quantity of Air / Quantity of fittings / Quantity of hose / App. hose length in inches			
3	3	3	- 18 -
RSQ			
R = roto			
E = elbows			
Q = QEV's			
SQ = silenced QEV's			
IR = integral roto			

Model	Speed of Response	No. of Hoses	Roto Part Number
LIM 106	slow	1	40067-730
LIM 206	fast	2	40067-730
LIM 108	slow	1	40067-740
LIM 211	fast	2	24181-014
LIM 114	slow	2	40067-740
LIM 316	fast	2	24181-040
LIM 118	slow	3	40067-740
LIM 327	fast	3	24181-045
LIM 130H	slow	4	24181-040
LIM 348	fast	4	24181-049



Air Tube Disc Clutches and Brakes

Low Inertia Brakes

Specifications

Model Size ATD-	Slip Torque Capacity Nm		Duty Factors HP/100 RPM				Max. Bore Rect. Key mm
	5.5 BAR	7 BAR	A	B	C	D	
LIM 104	90	113	1.6	1.2	0.6	0.3	25
LIM 204	90	225	3.2	2.4	1.2	0.6	
LIM 106	340	435	6.2	4.4	2.2	1.1	50
LIM 206	680	870	12.5	8.8	4.4	2.2	
LIM 108	620	790	11.1	8	4	2	57
LIM 208	1240	1580	22.2	16	8	4	
LIM 308	1865	2375	33.3	24	12	6	
LIM 111	1400	1785	25	18	9	5	64
LIM 211	2800	3570	50	36	18	10	
LIM 311	4235	5390	75	54	27	15	
LIM 114	2435	3100	44	31	16	8	89
LIM 214	4870	6200	88	62	32	16	
LIM 314	7355	9365	132	93	48	24	
LIM 116	3360	4275	60	46	24	12	102
LIM 216	6720	8550	120	92	48	24	
LIM 316	10080	12825	180	139	72	36	
LIM 118	5705	7260	102	75	35	21	121
LIM 218	11410	14520	204	150	70	42	
LIM 318	17115	21780	306	225	105	63	
LIM 121	7755	9870	139	107	55	28	152
LIM 221	15510	19740	277	213	111	55	
LIM 321	23265	29610	416	320	166	83	
LIM 124H	13575	17275	243	180	90	40	152
LIM 224H	27150	34550	487	360	180	80	
LIM 324H	40725	51825	729	540	270	120	
LIM 127	15260	19420	273	210	109	55	165
LIM 227	30520	38840	546	420	218	109	
LIM 327	45780	58260	819	630	327	164	
LIM 130H	29630	37710	519	380	190	100	184
LIM 230H	59260	75420	1038	760	380	200	
LIM 330H	88890	113130	1557	1140	570	300	
LIM 136	44920	57175	805	600	295	165	229
LIM 236	89840	114350	1610	1200	590	330	
LIM 336	134760	171525	2415	1800	885	495	
LIM 142	69160	81660	1150	850	425	235	355
LIM 242	128320	163320	2300	1700	850	470	
LIM 342	192480	244980	3450	2550	1275	705	
LIM 148	118800	151200	2225	1600	800	455	455
LIM 248	237600	302400	4450	3200	1600	915	
LIM 348	356400	453600	6675	4800	2400	1365	
LIM 260	473000	602000	9440	5950	3470	1940	480
LIM 360	709000	902300	14160	8925	5205	2910	
LIM 460	946000	1204000	18880	11900	6940	3880	

Maximum operating pressure is 8.5 BAR non cyclic / 7 BAR cyclic

Air Tube Disc Clutches and Brakes

A

Model Size ATD-	Balance Speed RPM	Hub & C.P.		Airtube Volume cm ³		Total Brake Wt. kg	Hub & Center Plate	
		Reg- Speed RPM	High Speed RPM*	New	Worn		Wt. kg	J=mr ² kgm ²
LIM 104						7	0.7	0.001
LIM 204	3325	5250	5250*	14.8	56	6	0.8	0.002
LIM 106						12	2.9	0.010
LIM 206	2225	3800	5700*	30	195	18	5.5	0.019
LIM 108						28	5.0	0.023
LIM 208	1675	2870	4300*	56	300	32	8.6	0.042
LIM 308						39	12.7	0.084
LIM 111						59	10.4	0.097
LIM 211	1200	2090	3125*	90	500	75	20.4	0.190
LIM 311						94	54.9	0.295
LIM 114						83	20.9	0.240
LIM 214	950	1640	2450*	125	700	106	34.9	0.464
LIM 314						132	54.9	0.704
LIM 116						115	26.8	0.430
LIM 216	835	1430	2150*	161	919	148	48.1	0.826
LIM 316						162	68.5	1.248
LIM 118						141	33.1	0.632
LIM 218	750	1270	1910*	251	1400	171	54.4	1.214
LIM 318						209	81.6	1.821
LIM 121						209	52.6	1.35
LIM 221	650	1090	1650*	300	1599	261	89.8	2.57
LIM 321						328	141.5	5.14
LIM 124H						280	60.0	2.4
LIM 224H	550	950	1410*	490	2606	381	117.9	4.6
LIM 324H						465	172.0	6.8
LIM 127						345	84.8	4.1
LIM 227	500	850	1,250*	490	2606	419	149.2	8.1
LIM 327						504	251.7	12.0
LIM 130H						441	135.2	8.0
LIM 230H	450	765	1130*	960	5096	612	247.7	15.6
LIM 330H						794	367.4	20.1
LIM 136						630	209.1	15.7
LIM 236	375	640	950*	1803	6801	904	321.1	30.6
LIM 336						1184	514.4	46.0
LIM 142						892	308	30
LIM 242	325	545	805*	2098	7997	1239	543	58
LIM 342						1680	601	76
LIM 148						1432	499	75
LIM 248	275	475	705*	3550	13500	2132	881	141
LIM 348						2966	1338	208
LIM 260						4288	1164	298
LIM 360	225	380	575*	8407	29300	5281	1755	448
LIM 460						6577	2585	635

* Consult Factory for Special Assembly Number.

Air Tube Disc Clutches and Brakes

Low Inertia Brakes (Sizes 8-36)

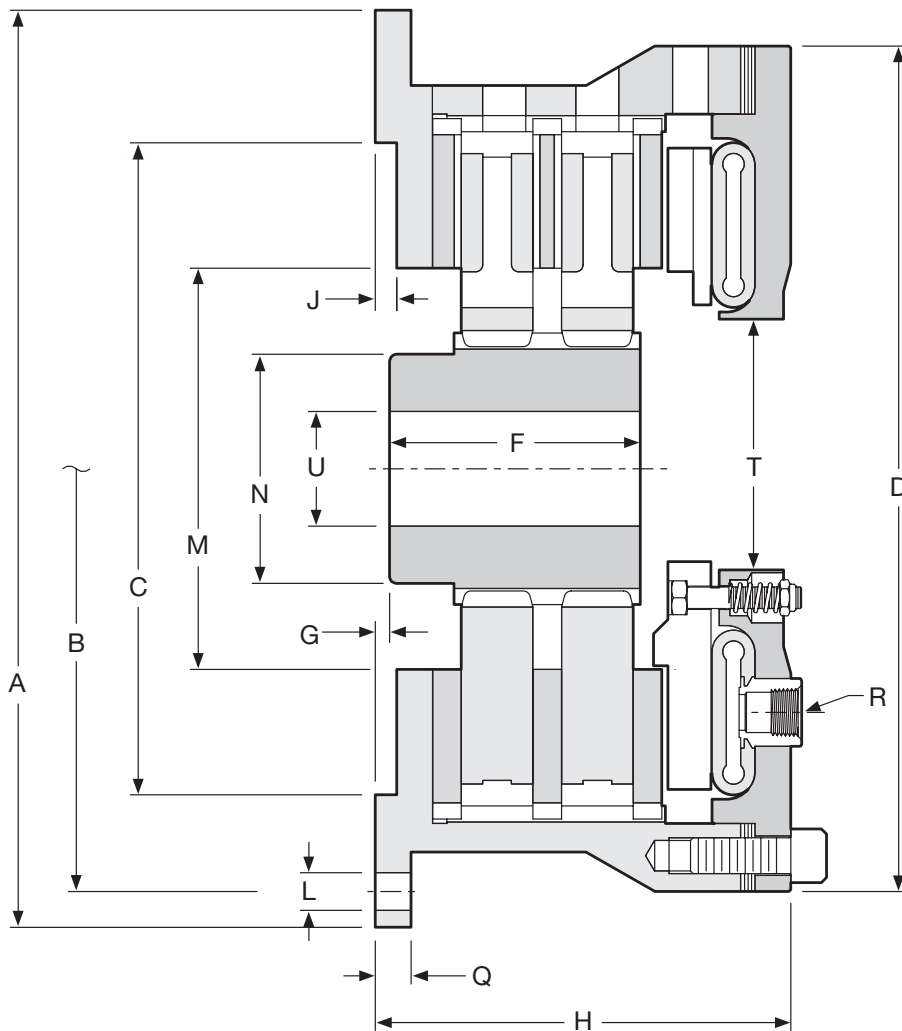

Air Tube Disc Clutches and Brakes

Dimensions: mm

Model Size ATD-	A	B Hole Circle	C ⁽¹⁾ Pilot	D	F	G	H
LIM 108					50.8		115.8
LIM 208	308.1	282.58	220	282.7	82.6	6.4	150.9
LIM 111					69.9	3.3	138.2
LIM 211	406.4	374.65	295	374.7	111.3	6.4	182.6
LIM 114					95.3	3.3	153.9
LIM 214	476.3	444.50	370	444.5	114.3	9.7	203.2
LIM 116					101.6		160.3
LIM 216					120.7		209.6
LIM 316	539.8	508.00	410	508.0	168.4	9.7	258.8
LIM 118					101.6		169.9
LIM 218					120.7		219.2
LIM 318	590.6	558.80	470	558.8	165.1	11.2	270.0
LIM 121					101.6		187.5
LIM 221					130.3		236.5
LIM 321	685.8	647.70	540	632.0	181.1	19.1	298.5
LIM 124H					101.6	17.5	193.8
LIM 224H					130.3	19.1	252.5
LIM 324H	762	730.25	620	736.6	190.5	19.1	311.2
LIM 127							
LIM 227					174.8	19.1	263.7
LIM 327	831.9	800.10	700	787.4	—	—	—
LIM 130H							
LIM 230H					181.1	47.8	300.0
LIM 330H	939.8	901.70	775	882.7	301.8	16.0	388.9
LIM 136					143.0		241.3
LIM 236	1104.9	1066.80	925	1041.4	228.6	16.0	327.2

⁽¹⁾ Dimension "C" is given as a nominal figure. The applicable tolerance is ISO H7.
(Consult factory for drawing before final layout.)

Dimensions: mm

Model Size ATD-	J	L		M	N	Q	R		T	U	
		No. -	Size				No. -	Size		Min.	Max.
LIM 108		6 x	Ø14				2 -	1/2 NPT	57	25	50.8
LIM 208	6.4			136.7	88.9	12.7					
LIM 111		6 x	Ø18				2 -	1/2 NPT	82	25	63.5
LIM 211	9.7			177.8	101.6	16.0					
LIM 114		8 x	Ø18				2 -	1/2 NPT	127	35.1	88.9
LIM 214	9.7			239.8	139.7	16.0					
LIM 116		12 x	Ø18				2 -	1/2 NPT	155	35.1	101.6
LIM 216	9.7			266.7	152.4	16.0					
LIM 316											
LIM 118		12 x	Ø18				3 -	1/2 NPT	196	50.8	120.7
LIM 218	9.7			317.5	177.8	16.0					
LIM 318											
LIM 121		12 x	Ø18				3 -	1/2 NPT	235	50.8	152.4
LIM 221	7.9			368.3	228.6	19.1					
LIM 321											
LIM 124H		12 x	Ø18				3 -	1/2 NPT	336	50.8	152.4
LIM 224H	6.4			368.3	228.6	19.1					
LIM 324H											
LIM 127		16 x	Ø18				3 -	1/2 NPT	336	63.5	165.1
LIM 227	6.4			412.8	228.6	19.1					
LIM 327											
LIM 130H		18 x	Ø22				4 -	1/2 NPT	380	63.5	184.2
LIM 230H	6.4			489	254	19.1					
LIM 330H											
LIM 136		16 x	Ø18				4 -	1/2 NPT	570	152.4	228.6
LIM 236	6.4			600.2	304.8	22.4					

(Consult factory for drawing before final layout.)



Air Tube Disc Clutches and Brakes

Low Inertia Brakes (Sizes 6, 42-60)

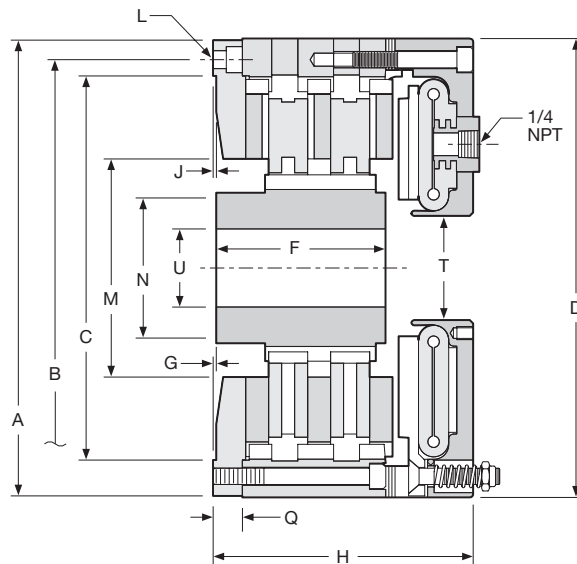

Size 6

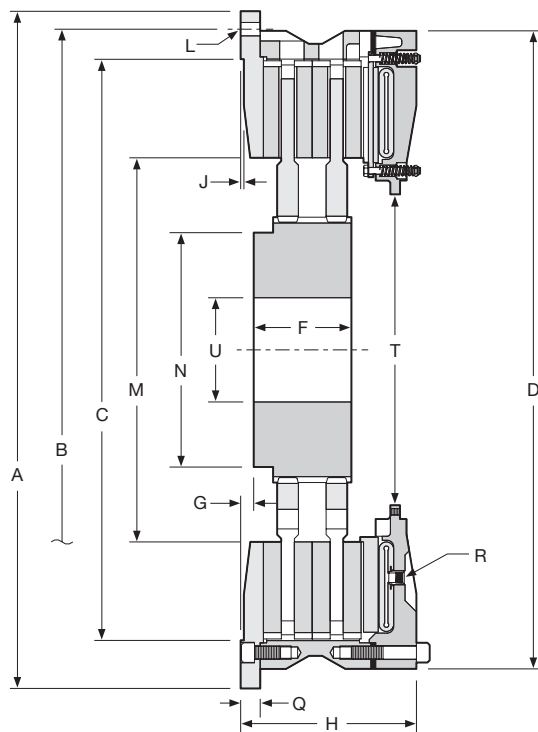

Sizes 42-60

Air Tube Disc Clutches and Brakes



Dimensions: mm

Model Size ATD-	A	B Hole Circle	C ⁽¹⁾ Pilot	D	F	G	H
LIM 106					50.8	0.0	95.3
LIM 206	222.3	203.20	190	223.8	82.6	1.5	127.0
LIM 142					143.0	25.40	247.7
LIM 242	1320.8	1250.95	1070	1,244.6	190.5		342.9
LIM 148					152.4	0.0	271.5
LIM 248	1549.4	1473.20	1320	1,441.5	222.3	25.4	382.5
LIM 260					238.3		539.8
LIM 360	1790.7	1892.30	1590	1,790.7	311.2	88.9	581.2

⁽¹⁾ Dimension "C" is given as a nominal figure. The applicable tolerance is ISO H7.
(Consult factory for drawing before final layout.)

Dimensions: mm

Model Size ATD-	J	L		M	N	Q	R		T	U	
		No.-	Size				No. -	Size		Min.	Max.
LIM 106											
LIM 206	1.5	4 x	Ø9	106.4	68.3	14.2	2 -	1/4 NPT	50.8	15.2	50.8
LIM 142											
LIM 242	6.4	24 x	Ø26	749.3	457.2	38.1	4 -	1/2 NPT	606.6	203.2	355.6
LIM 248 ⁽²⁾		24 x	M24								
LIM 348 ⁽²⁾	6.4	24 x	Ø24	812.8	654.1	38.1	4 -	1/2 NPT	641.4	254.0	457.2
LIM 260 ⁽²⁾											
LIM 360 ⁽²⁾	9.5	24 x	2" NC	901.7	715.0	797.6	6 -	1/2 NPT	723.9	279.4	482.6

⁽²⁾ No flange or backplate
(Consult factory for drawing before final layout.)

Air Tube Disc Clutches and Brakes

Low Inertia Brake Air Hose Kits

Air sets are optional and consist of elbows (or quick exhaust valves), hoses and pipe fittings. For cycling duties and fast response time of brake engagement, elbows should be used. Customer's fast acting solenoid valve should be mounted as close as possible to the brake. For applications where fast disengagement of the brake is the main criteria the Quick Exhaust Valves should be used. Alternatively, the air supply can be piped up directly to the BSPT/NPT airtube connections (spud). Use flexible connections.

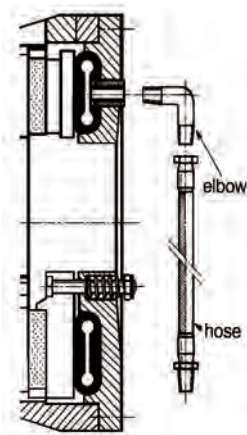

Air hose kits contain all necessary parts (fittings, hoses and extensions) to completely plumb the brake air system.

Optional Quick Release Valves can replace elbows on most units. See pages 20 and 21.

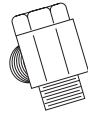

Hose and Inlet Connections

Brake	Quantity of hoses	Inlet Connection 'A'
104	1	1/8" BSPT male
106	1	1/4" BSPT male
108-208	1	1/2" BSPT male
111-316	2	1/2" BSPT female
118-321	3	3/4" BSPT female
124H-327	3	1 1/4" BSPT female
130H-348H	4	1 1/4" BSPT female

Hose Configurations

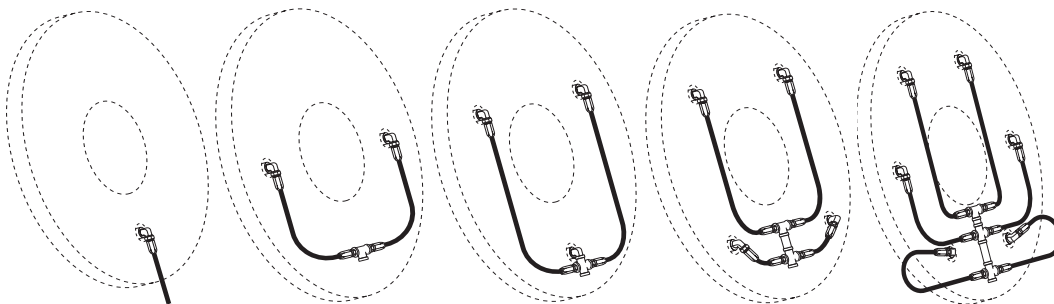

Low Inertia Clutches and Brakes

Component Parts

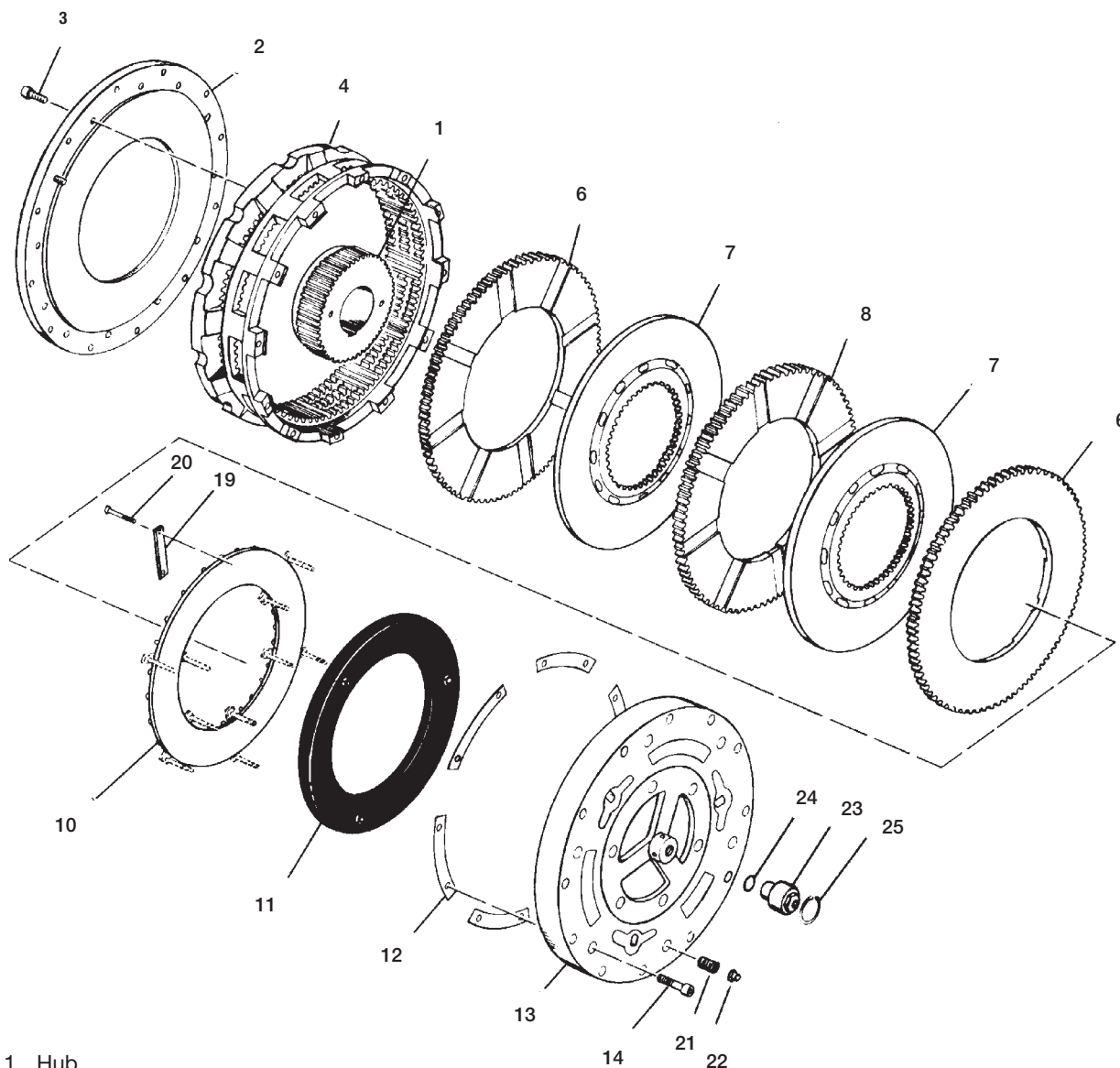

- | | | |
|---|---------------------------|---------------------|
| 1. Hub | 10. Pressure Plate | 21. Release Springs |
| 2. Demountable Back Plate | 11. Airtube | 22. Flexloc Nuts |
| 3. Socket Head Capscrews | 12. Shims | 23. Roto-coupling |
| 4. Ring | 13. Airtube Holding Plate | 24. "O" Ring |
| 6. Grooved Friction Disc
(grooved on one side) | 14. Socket Head Capscrews | 25. Snap Ring |
| 7. Center Plate | 19. Pressure Plate Lugs | |
| 8. Grooved Friction Disc
(grooved on both sides) | 20. Hex Head Capscrews | |



Air Tube Disc Clutches and Brakes

High Torque Clutches

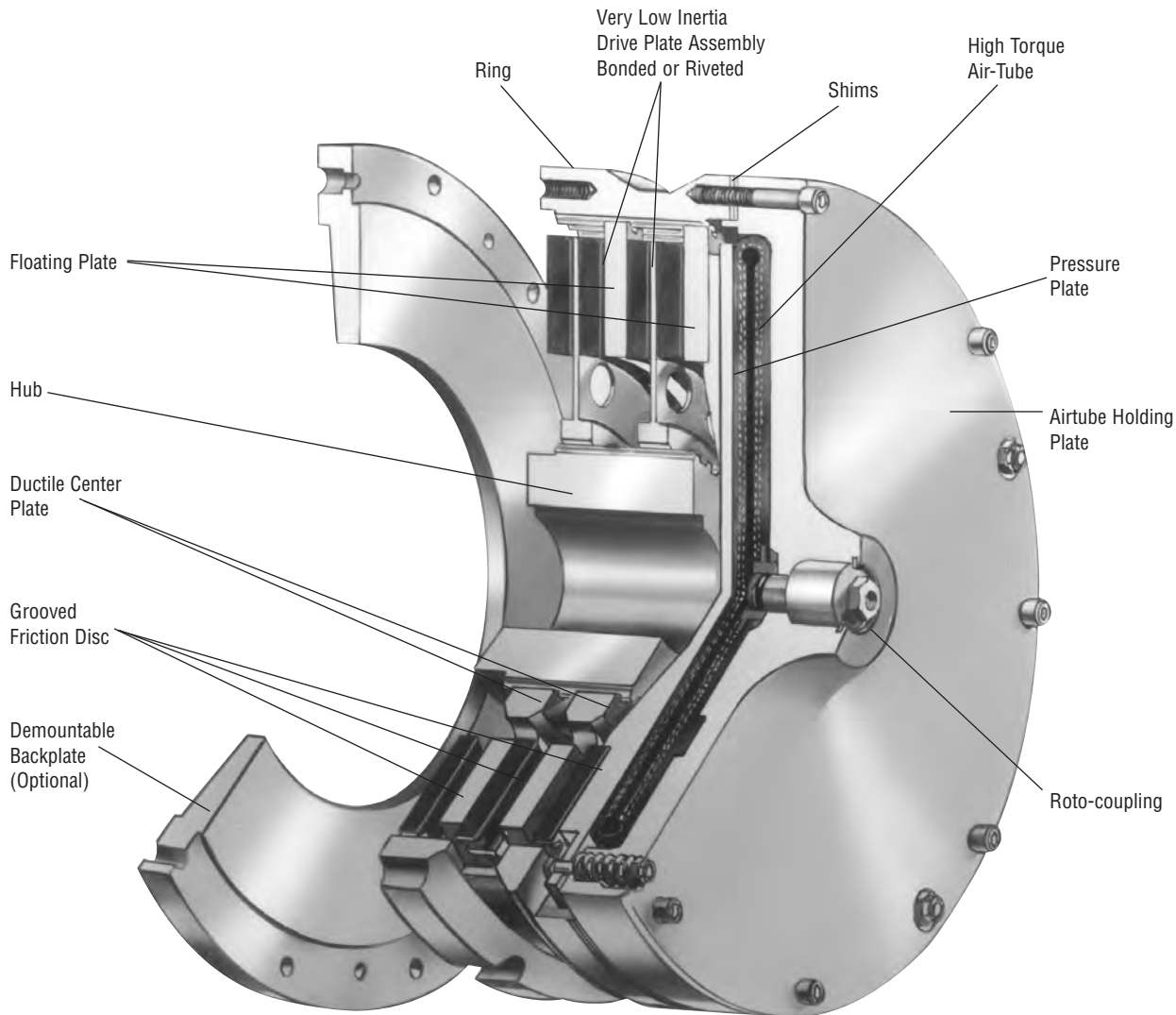

Wichita High Torque Clutches provide the highest torque to size ratios of any Wichita Clutch. They provide smooth controlled starts and stops and are designed for minimum power loss due to low rotating inertia.

- Extremely fast response
- No lubrication
- High torque to size ratio
- Low rotating inertia

Selection Requirements

To properly select a High Torque Clutch and Low Inertia Brake, the following information must be determined.

1. Torque necessary to do the work (clutch)
2. Rotating inertia to be stopped and started
3. Heat generated by each stop/start
4. Torque necessary to stop inertia (brake)
5. Shaft size

High Torque Clutches

Component Parts

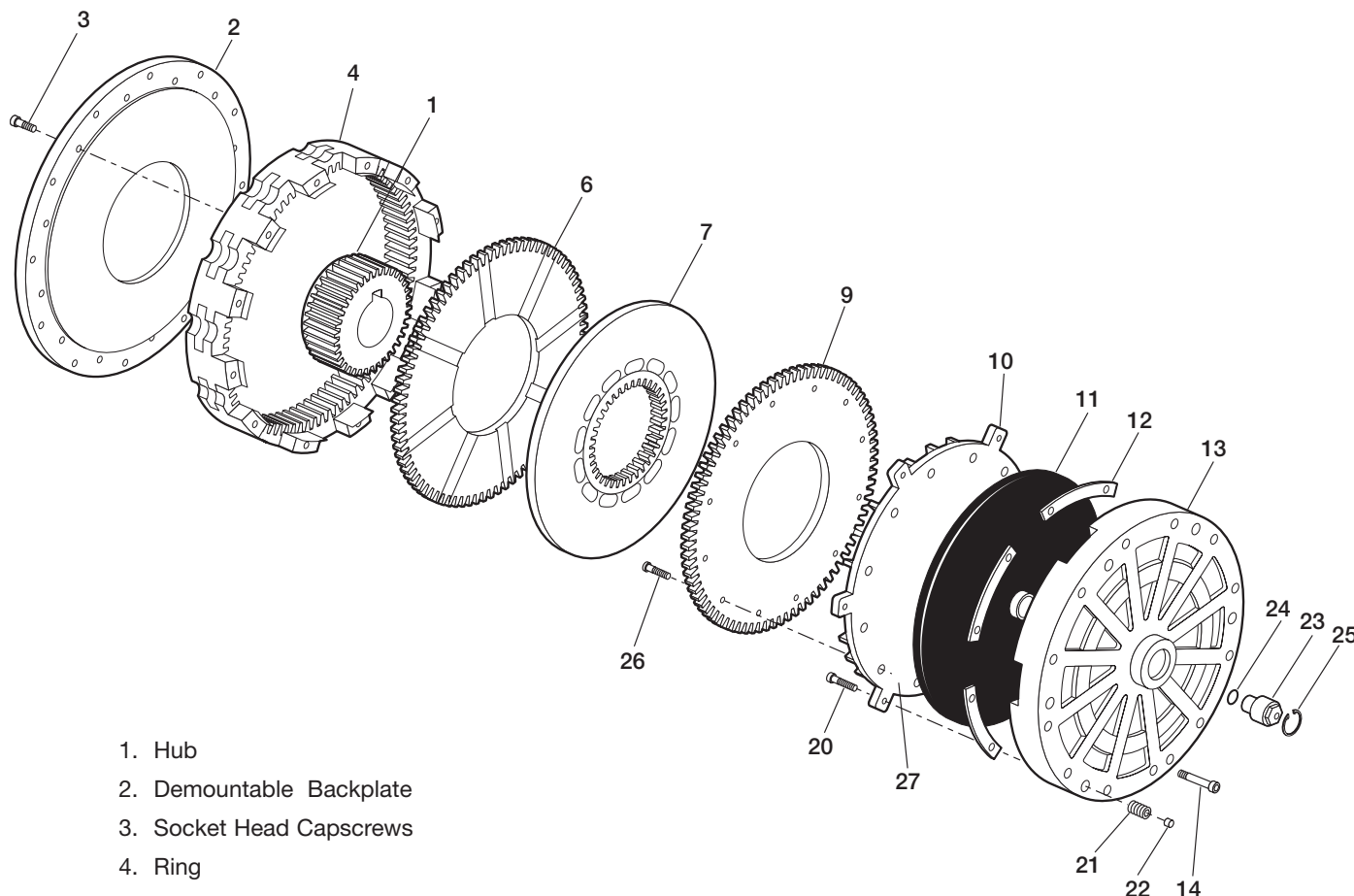

- 1. Hub
- 2. Demountable Backplate
- 3. Socket Head Capscrews
- 4. Ring
- 6. Grooved Friction Disc (grooved on one side)
- 7. Center Plate
- 9. Grooved Friction Disc
- 10. Pressure Plate
- 11. Pancake Air Tube
- 12. Shims
- 13. Air Tube Holding Plate
- 14. Socket Head Capscrews
- 20. Hex Head Capscrew
- 21. Release Springs
- 22. Flexloc Nut
- 23. Internal Roto-Coupling
- 24. "O" Ring
- 25. Snap Ring
- 26. Flathead Socket Capscrew
- 27. Slotted Flush Nut



Air Tube Disc Clutches and Brakes

High Torque Clutches

Specifications

Model Size ATD-	Slip Torque Capacity Nm		Duty Factors HP/100 RPM				Max. Bore Rect. Key mm
	5.5 BAR	7 BAR	A	B	C	D	
HTM 104	90	113	1.6	1.2	0.6	0.3	25
HTM 204	180	226	3.2	2.4	1.2	0.6	
HTM 106	475	602	8	5.7	2.8	1.4	50
HTM 206	950	1204	16	11.4	5.7	2.8	
HTM 108	977	1243	17	13	6	3	60
HTM 208	1953	2486	34	25	13	6	
HTM 308	2930	3729	51	38	19	9	
HTM 111	2220	2825	38	28	14	7	67
HTM 211	4440	5650	76	56	28	14	
HTM 311	6660	8475	114	84	42	21	
HTM 114	4261	5423	75	55	27	14	105
HTM 214	8522	10846	160	114	55	28	92
HTM 314	12783	16269	225	165	81	42	118
HTM 116	6600	8400	118	91	47	24	102
HTM 216	13200	16800	236	182	94	47	
HTM 316	19800	25200	354	272	142	71	
HTM 118	9321	11863	165	120	60	30	120
HTM 218	18642	23726	330	240	120	60	
HTM 318	27963	35589	495	360	180	90	
HTM 121	15091	19207	270	208	108	54	152
HTM 221	30182	38414	540	415	216	108	
HTM 321	45273	57621	810	623	324	162	
HTM 124	21305	27116	385	280	140	70	152
HTM 224	42610	54232	770	560	280	140	
HTM 324	63915	81348	1155	840	420	210	
HTM 424	85220	108464	1540	1120	560	280	165
HTM 127	32144	40911	575	442	230	115	
HTM 227	64288	81821	1150	884	460	230	
HTM 327	96432	122732	1724	1326	690	345	152
HTM 130	41722	53101	750	535	270	135	184
HTM 230	83445	106203	1500	1070	540	270	
HTM 330	125167	159304	2250	1605	810	405	203
HTM 136	44920	57175	1555	1120	560	280	203
HTM 236	89840	114350	3100	2240	1120	560	
HTM 336	134760	171525	4665	3360	1680	840	235
HTM 436	180383	229579	6220	4480	2240	1120	267
HTM 148	209500	266637	3745	2690	1345	670	455
HTM 248	419000	533273	7490	5380	2690	1345	
HTM 348	628500	799910	11235	8070	4035	2010	

Maximum Air Pressure is 7 BAR.

Air Tube Disc Clutches and Brakes

A

Model Size ATD-	Balance Speed RPM	Max. Speed		Airtube Volume cm ³		Total Clutch		Hub & Center Plate	
		Reg- Speed RPM	High Speed RPM*	New	Worn	Wt. kg	J=mr ² kgm ²	Wt. kg	J=mr ² kgm ²
HTM 104	NA	2100	2600*	21.3	82	5	0.018	0.7	0.001
HTM 204						6	0.023	1.8	0.002
HTM 106	NA	2100	2600*	49	229	10	0.059	2.9	0.010
HTM 206						20	0.131	5.7	0.021
HTM 108	1675	1890	2500	82	492	50	0.903	6.8	0.057
HTM 208						67	1.211	13.6	0.110
HTM 308						64	1.265	18.4	0.169
HTM 111	1200	1430	2200*	131	787	60	1.14	10.4	0.097
HTM 211						77	1.43	20.4	0.190
HTM 311						94	2.19	54.9	0.295
HTM 114	950	1225	1930*	197	1,229	54	1.31	21.8	0.236
HTM 214						120	2.95	35.4	0.472
HTM 314						127	3.04	14.1	0.637
HTM 116	835	1080	1700*	164	918	107	3.54	22.7	0.346
HTM 216						134	4.43	48.5	0.826
HTM 316						162	5.06	68.5	1.206
HTM 118	950	985	1530*	295	1,655	170	7.67	36.3	0.658
HTM 218						220	8.43	53.5	1.214
HTM 318						240	10.54	81.6	1.897
HTM 121	650	850	1400*	623	3,294	253	14.08	45.8	1.31
HTM 221						316	18.00	89.8	2.57
HTM 321						343	16.86	131.5	5.14
HTM 124	550	765	1210*	819	4,097	318	20.99	60.8	2.4
HTM 224						417	26.77	117.9	4.6
HTM 324						540	36.09	175.1	6.9
HTM 424	500	700	1090*	1000	5293	586	38.66	211.4	8.8
HTM 127						449	33.1	76.2	4.1
HTM 227						541	40.8	137.9	8.1
HTM 327	641	49.9	206.4	11.9					
HTM 130	450	620	1000*	1311	6473	692	77.4	123.4	7.8
HTM 230						873	102.2	240.0	15.6
HTM 330						1016	114.7	362.9	20.9
HTM 136	375	525	800*	1966	12618	993	153.9	170.6	15.5
HTM 236						1270	185.1	340.2	31.8
HTM 336						1461	205.1	547.0	48.1
HTM 436						1494	205.6	645.9	60.3
HTM 148	275	380	580*	3277	23434	3323	1084	776	77
HTM 248						3854	1195	904	144
HTM 348						4431	1349	1228	207

* Consult Factory for Special Assembly Number.

Air Tube Disc Clutches and Brakes

High Torque Clutches (Sizes 4-24)

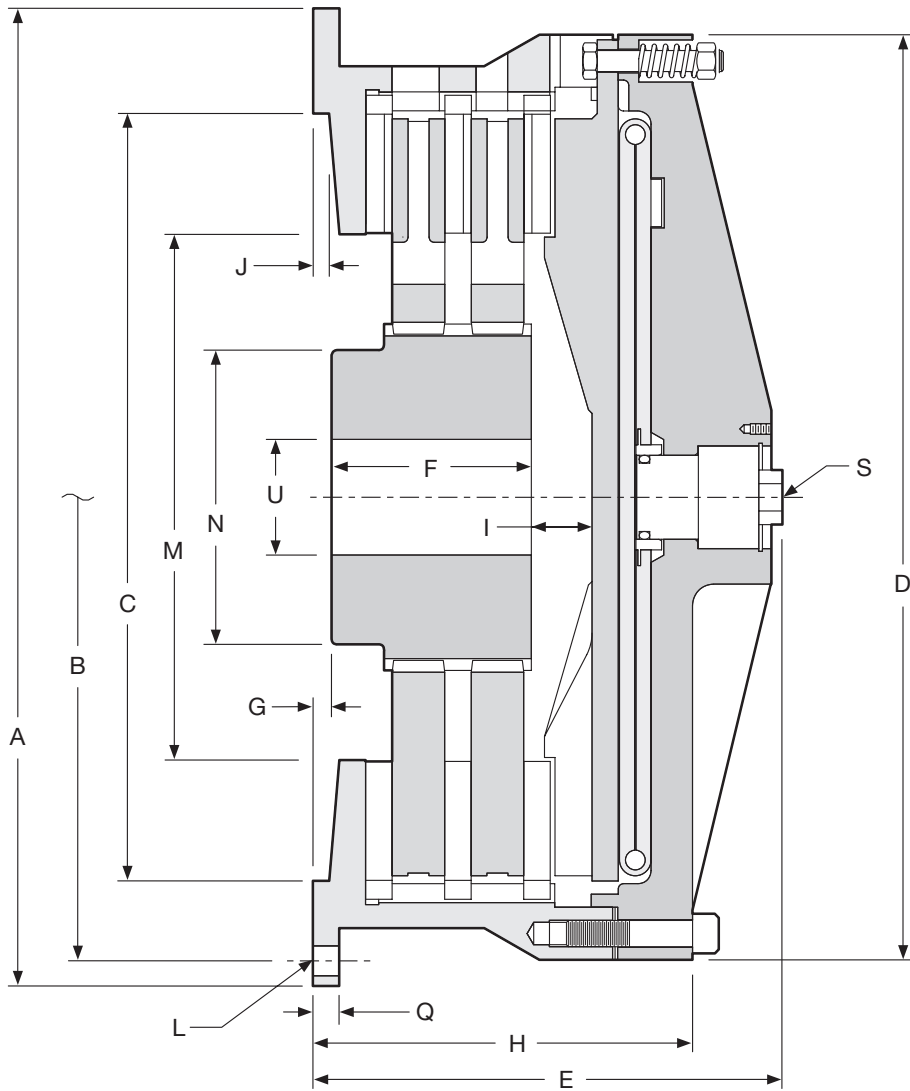

Air Tube Disc Clutches and Brakes



Dimensions: mm

Model Size ATD-	A	B Hole Circle	C ⁽¹⁾ Pilot	D	E	F	G	H
HTM 104 ⁽³⁾					85.9	25.4	1.5	63.5
HTM 204 ⁽³⁾	187.5	174.63	110	162.1	63.5	47.8	0.0	81.0
HTM 106 ⁽⁴⁾					127.8	50.8	0.0	115.1
HTM 206	222.3	203.20	190	223.8	158.8	82.6	1.5	146.1
HTM 108 ⁽²⁾					157.7	38.1	12.7	111.0
HTM 208 ⁽²⁾	308.1	282.58	220	282.7	191.0	73.2		144.3
HTM 111 ⁽²⁾					198.6	950.8	12.7	138.2
HTM 211 ⁽²⁾	406.4	374.65	295	374.7	244.6	95.3		184.2
HTM 114 ⁽²⁾					213.1	95.3	3.3	153.9
HTM 214	476.3	444.50	370	444.5	266.7	114.3	9.7	200.2
HTM 314 ⁽⁴⁾					254.0	114.3	9.7	200.2
HTM 116					232.7	69.9		172.2
HTM 216	539.8	508.00	410	508.0	283.5	120.7	9.7	220.0
HTM 316					331.7	168.4		271.5
HTM 118					235.7	69.9		181.9
HTM 218	590.6	558.80	470	558.8	283.5	120.7	11.2	229.4
HTM 318					325.4	165.1		277.9
HTM 121					258.8	73.2	17.5	192.0
HTM 221	685.8	647.70	540	632.0	300.5	130.3	19.1	246.1
HTM 321					360.4	181.1	19.1	306.3
HTM 124					255.5	88.9	9.7	212.9
HTM 224	762.0	730.25	620	711.2	314.5	88.9	19.1	271.5
HTM 324					373.1	130.3	19.1	330.2
HTM 424 ⁽⁴⁾	736.6	679.5	650	711.2	397.3	212.9	18.3	350.8

⁽¹⁾ Dimension "C" is given as a nominal figure. The applicable tolerance is ISO H7. (Consult factory for drawing before final layout.)

Dimensions: mm

Model Size ATD-	I	J	L		M	N	Q	S	U	
			No. -	Size					Min.	Max.
HTM 104	9.7			—	73.2	65.5	9.7	5/8-18NF		
HTM 204	16	3.3							12.7	25
HTM 106	23.9									
HTM 206	20.8	1.5	4 x	Ø9	106.4	68.3	14.2	5/8-18NF	25	50.8
HTM 108	20.6									
HTM 208	19.1	6.4	6 x	Ø14	136.7	91.9	12.7	1/4 NPT	25	60.5
HTM 111	26.9									
HTM 211	28.4	9.7	6 x	Ø18	177.8	104.6	28.7	1/2 NPT	25	66.8
HTM 114	26.9	9.7	8 x	Ø18	239.8	142.7	28.7			
HTM 214	20.6	9.7	8 x	Ø18	239.8	139.7	16.0	1/2 NPT	35.1	92.2
HTM 314	23.9	3.3	8 x	5/8-11NC	241.3	169.2	—			117.6
HTM 116	31.8			Ø18						
HTM 216	31.8	9.7	12 x	Ø18	266.7	152.4	16.0	1/2 NPT	35.1	101.6
HTM 316	28.7			Ø18						
HTM 118				Ø18						
HTM 218	36.6	9.7	12 x	Ø18	317.5	177.8	16.0	1/2 NPT	50.8	120.7
HTM 318				Ø18						
HTM 121	38.1			Ø18						
HTM 221	33.3	7.9	12 x	Ø18	368.3	228.6	19.1	1/2 NPT	50.8	152.4
HTM 321	36.6			Ø18						
HTM 124	28.7			Ø18						
HTM 224	35.1	6.4	12 x	Ø18	368.3	228.6	19.1	1/2 NPT		
HTM 324	39.6			Ø18					50.8	152.4
HTM 424 ⁽⁴⁾	39.6	3.3	12 x	5/8-11NC	368.3	228.6	—	1/2 NPT	50.8	152.4

⁽²⁾ Non-Ventilated center plate, "centerplate is solid".

⁽³⁾ Drive plate assembly, "friction material is attached to a drive plate".

⁽⁴⁾ Less backplate.

(Consult factory for drawing before final layout.)

Air Tube Disc Clutches and Brakes

High Torque Clutches (Sizes 27-48)

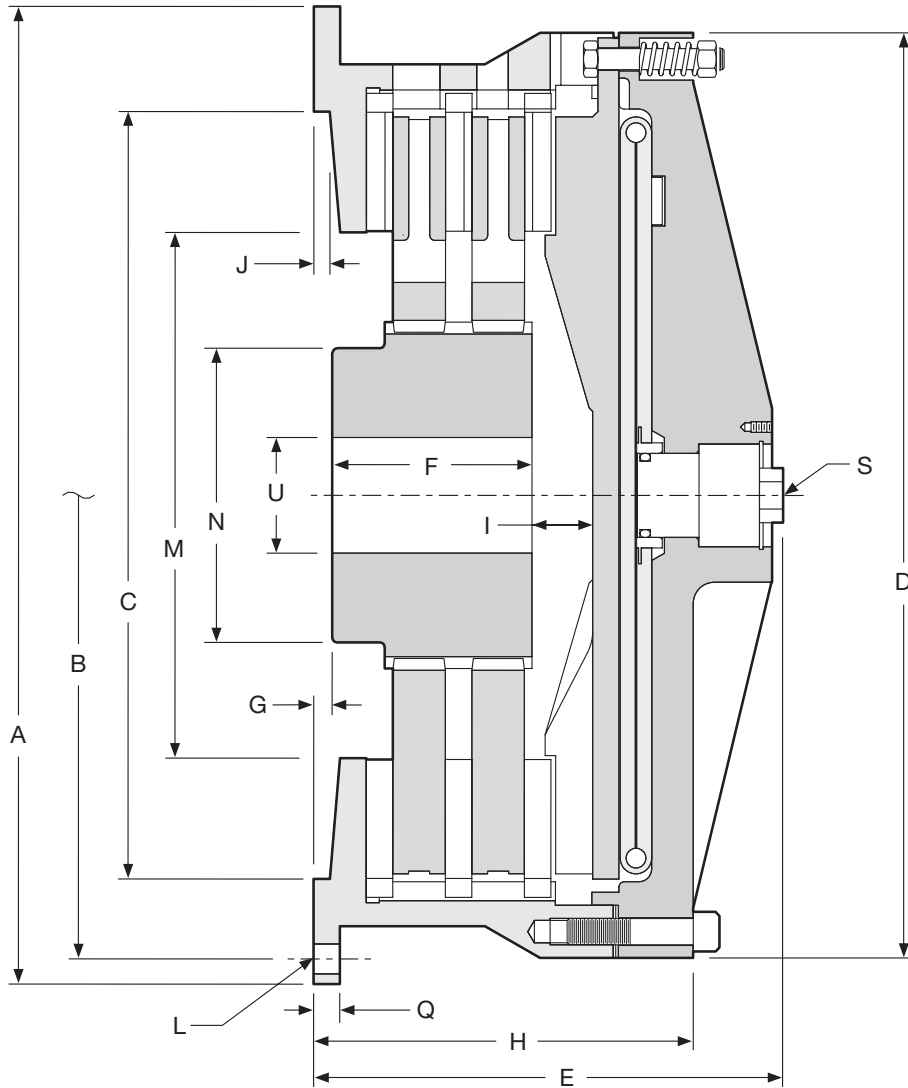

Air Tube Disc Clutches and Brakes



Dimensions: mm

Model Size ATD-	A	B Hole Circle	C ⁽¹⁾ Pilot	D	E	F	G	H
HTM 127					262.6	88.9		215.9
HTM 227	831.9	800.10	700	787.4	323.9	139.7	19.1	277.1
HTM 327					390.9	201.7		338.8
HTM 130					290.6	108.0		255.5
HTM 230	939.8	901.70	775	917.7	374.7	190.5	19.1	339.9
HTM 330					412.8	241.3		384.3
HTM 136					301.8	104.9	28.7	295.4
HTM 236	1104.9	1066.80	925	1054.1	388.9	190.5	28.7	382.5
HTM 336					476.3	273.1	31.8	469.9
HTM 436 ⁽²⁾	1044.4	1009.7	960	1044.4	414.3	226.1	26.9	431.8
HTM 148	1525.0	1473.2		1498.6	671.6	152.4	25.4	435.1
HTM 248	1574.8	1524.0	1320	1447.8	765.0	222.3	44.5	528.6
HTM 348 ⁽²⁾	1525.0	1473.2		1498.6	595.4	320.8	0.0	595.4

⁽¹⁾ Dimension "C" is given as a nominal figure. The applicable tolerance is ISO H7. (Consult factory for drawing before final layout.)

Dimensions: mm

Model Size ATD-	I	J	L		M	N	Q	S	U	
			No. -	Size					Min.	Max.
HTM 127	38.1					266.7		1/2 NPT		165.1
HTM 227	41.4	6.4	16 x	Ø18	412.8	266.7	19.1	1 NPT	63.5	165.1
HTM 327	41.4					228.6		1-1/2 -12NF		152.4
HTM 130	35.1					279.4		1/2 NPT		184.2
HTM 230	35.1	6.4	18 x	Ø22	489	279.4	19.1	1/2 NPT	63.5	184.2
HTM 330	25.4					304.8		1-1/2 -12NF		203.2
HTM 136						304.8				203.2
HTM 236	38.1	6.4	18 x	Ø26	600.2	304.8	38.1	1/2 NPT	152.4	203.2
HTM 336						355.6				235.0
HTM 436 ⁽²⁾	48.5	4.8	14 -	3/4-10NC 4 - 1.00" Pins	603.3	404.4	—	1/2 NPT	152.4	266.7
HTM 148	68.6	6.4	24 x	M36	812.8	654.1	44.5	2 NPT	152.4	457.2
HTM 248	87.4						38.1			
HTM 348 ⁽²⁾	100.6	5.8	24 x	M36	809.8	609.6	38.1	2-1/2 NPT	152.4	457.2

⁽²⁾ Less backplate.

(Consult factory for drawing before final layout.)

Air Tube Disc Clutches and Brakes

Spring-Set Air Release Brakes

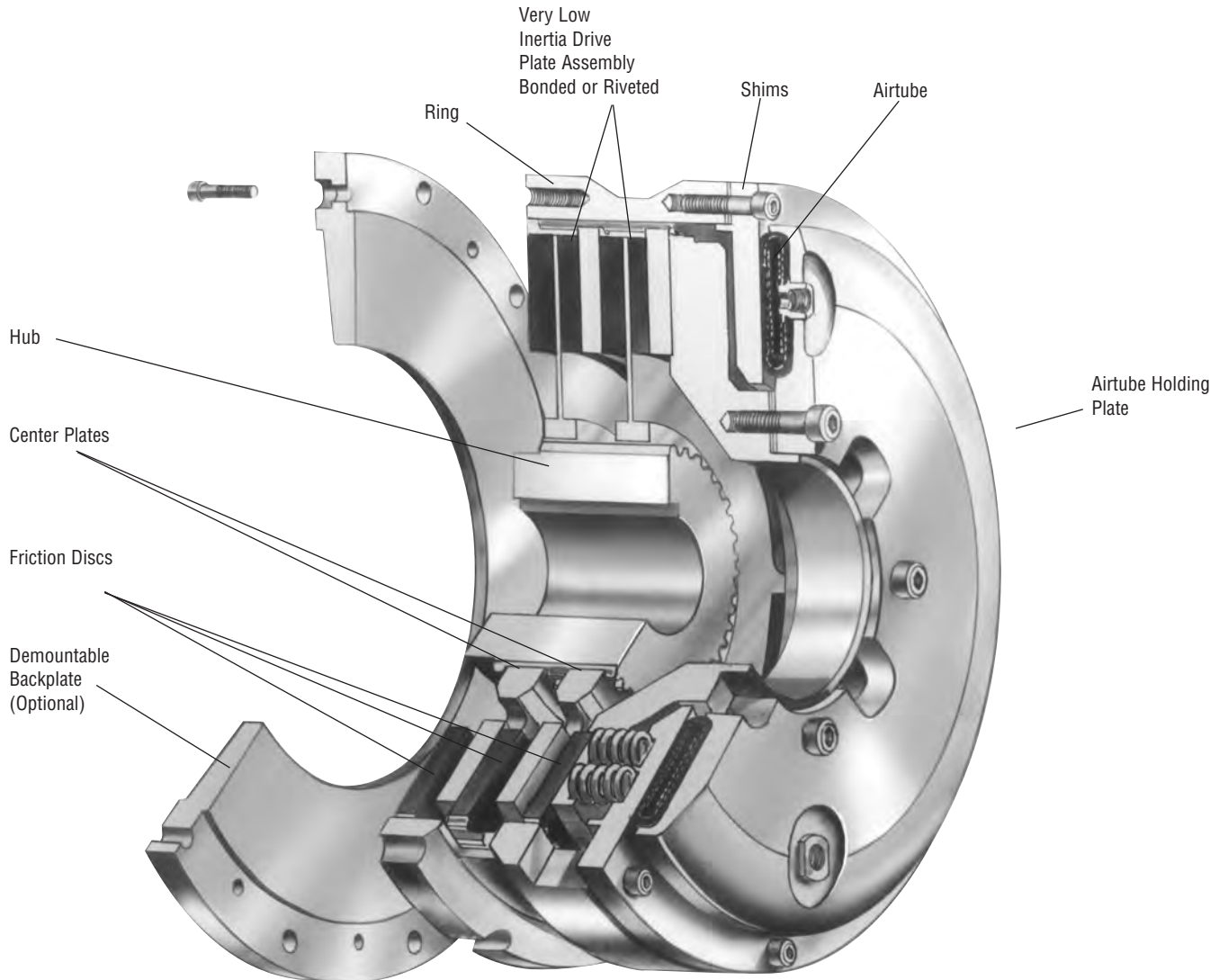

Wichita Spring-Set Air Release Brakes are ideal for fail to brake on condition protection of process equipment. Constructed of high strength cast iron, this improved design has thick friction discs for longer wear life. The fast acting airtube design assures quick, smooth stops.

- No lubrication
- No adjustment
- Available in vertical mount
- Quick, simple installation

Selection requirements

The selection of a Low Inertia Brake is based on:

1. Torque required to stop a load
2. Friction area necessary to absorb rotational energy
3. Contact velocity of rotating discs
4. Maximum bore capacity of unit

Low Inertia Spring-Set Brake Component Parts

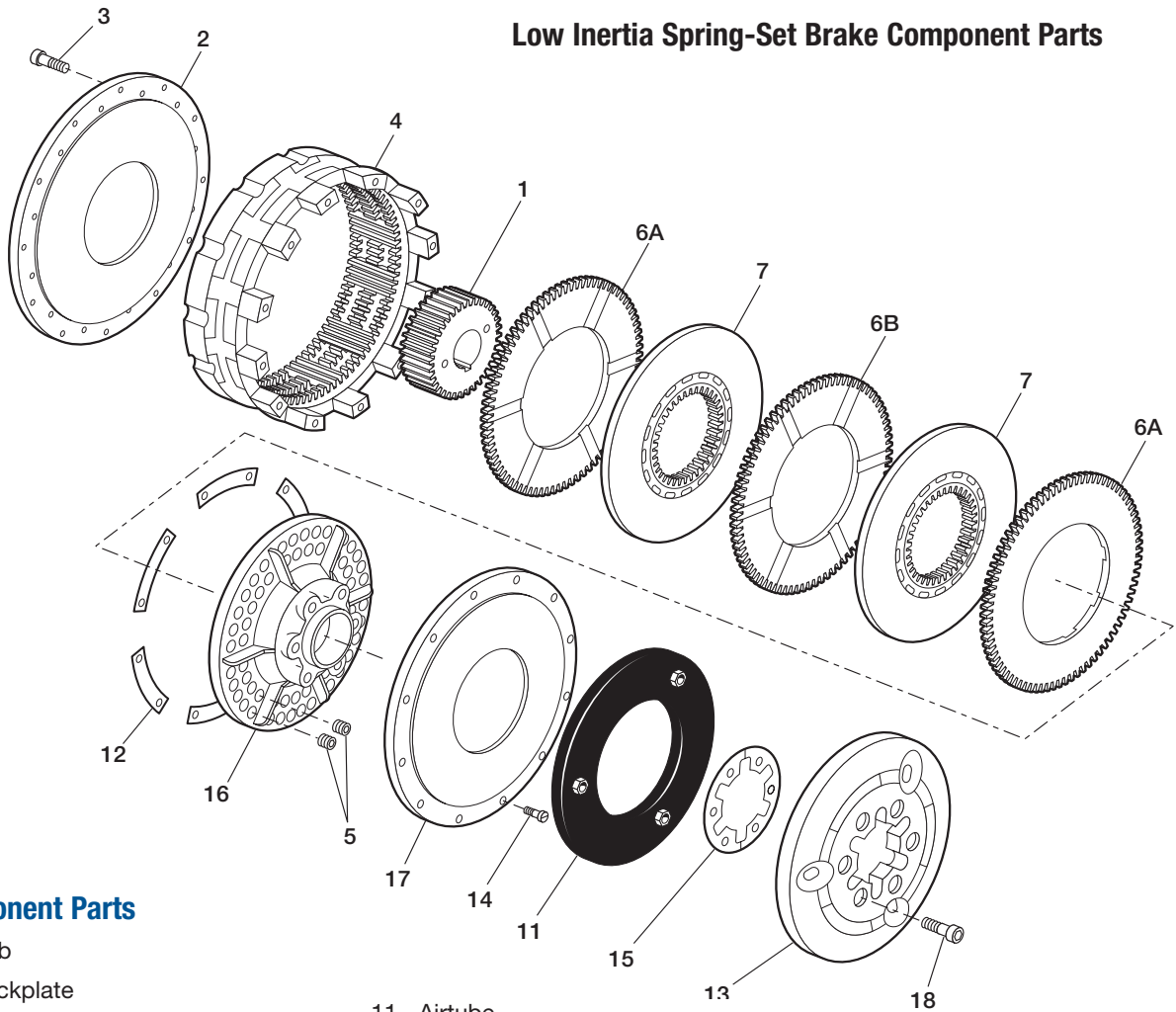

Component Parts

- | | |
|--|--|
| <ul style="list-style-type: none"> 1. Hub 2. Backplate 3. Socket Head Capscrews 4. Ring 5. Springs 6A. Grooved Friction Disc (grooved on one side) 6B. Grooved Friction Disc (grooved on both sides) 7. Center Plate | <ul style="list-style-type: none"> 11. Airtube 12. O. D. Shims 13. Air Tube Holding Plate 14. Socket Head Capscrews 15. I.D. Shims 16. Spring Release Plate 17. Airtube Spring Plate 18. Socket Head Capscrews |
|--|--|

Spring-Set Brake Air Hose Kits

Hose Configurations

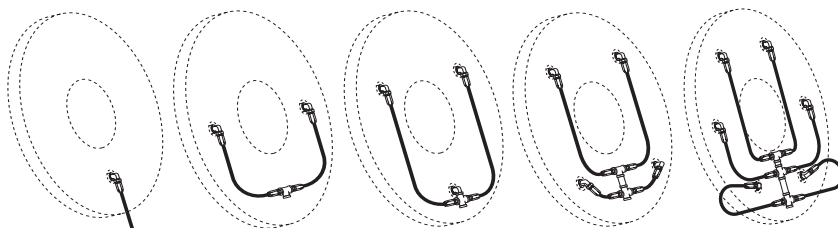

Air hose kits contain all necessary parts (fittings, hoses and extensions) to completely plumb the brake air system.

Optional Quick Release Valves can replace elbows on most units (see pages 20 and 21).

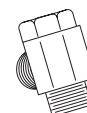

Air Tube Disc Clutches and Brakes

Spring-Set Brakes

Specifications

Model Size ATD-	Slip Torque Capacity Nm			Max. Bore Rect. Key (mm)
	4.5 BAR	5.5 BAR	7 BAR	
SSM 104H				25
SSM 106	251	328	418	
SSM 206	486	633	813	50
SSM 306	650	836	1022	
SSM 108	418	542	700	
SSM 208	802	1028	1356	57
SSM 308	994	1277	1514	
SSM 111	926	1186	1311	
SSM 211	1763	2260	2508	64
SSM 311	2181	2813	3209	
SSM 114	1638	2101	2791	
SSM 214	3118	4000	5231	89
SSM 314	4067	5050	6090	
SSM 116	2181	2689	3209	
SSM 216	3988	5050	6033	102
SSM 316	5593	7073	8474	
SSM 118	3548	4564	5830	
SSM 218	6779	8700	11298	120
SSM 318	9140	11524	13784	
SSM 121	4327	5355	6485	
SSM 221	8101	10033	12157	152
SSM 321	11321	14021	16992	
SSM 124H	8530	9784	—	
SSM 224H	15478	18213	—	152
SSM 324H	20212	25263	—	
SSM 127	8508	10643	12812	
SSM 227	15919	19907	23963	165
SSM 327	22223	27782	33443	
SSM 130H	18326	23918	29432	
SSM 230H	35024	45701	55982	184
SSM 330H	44684	56050	66648	
SSM 136H	28754	33894	44193	229
SSM 236H	53949	63722	85866	254
SSM 336H	76263	94916	114405	254
SSM 436H	98158	122167	147260	254
SSM 142	48017			
SSM 242	89933			355
SSM 342	121116			
SSM 148	78889			
SSM 248	150830			455
SSM 348	195006			
SSM 260	367755			
SSM 360	555982			480
SSM 460	605016			

* Not the standard 4.13 BAR/60 PSI release pressure. Consult Factory.

By choice a lower spring force unit is less stressed therefore preferred.

Air Tube Disc Clutches and Brakes

A

Model Size ATD-	Balance Speed RPM	Hub & Centre Plate		Airtube Volume cm ³		Total Brake Wt. kg	Hub & Center Plate	
		Reg- Speed RPM	High Speed RPM*	New	Worn		Wt. kg	J=mr ² kgm ²
SSM 104H	3325	5250	5250*	22	86	7	0.7	0.001
SSM 106						12	2.9	0.010
SSM 206	2225	3800	5700*	30	195	18	5.5	0.019
SSM 306						28	5.0	0.023
SSM 108						32	8.6	0.042
SSM 208	1675	2870	4300*	56	300	39	12.7	0.084
SSM 308						59	10.4	0.097
SSM 111						75	20.4	0.190
SSM 211	1200	2090	3125*	90	500	94	54.9	0.295
SSM 311						83	20.9	0.240
SSM 114						106	34.9	0.464
SSM 214	950	1640	2450*	125	700	132	54.9	0.704
SSM 314						115	26.8	0.430
SSM 116						148	48.1	0.826
SSM 216	835	1430	2150*	161	919	162	68.5	1.248
SSM 316						141	33.1	0.632
SSM 118						171	54.4	1.214
SSM 218	750	1270	1910*	251	1400	209	81.6	1.821
SSM 318						209	52.6	1.35
SSM 121						261	89.8	2.57
SSM 221	650	1090	1650*	300	1599	328	141.5	5.14
SSM 321						280	60.0	2.4
SSM 124H						381	117.9	4.6
SSM 224H	550	950	1410*	490	2606	465	172.0	6.8
SSM 324H						345	84.8	4.1
SSM 127						419	149.2	8.1
SSM 227	500	850	1250*	490	2606	504	251.7	12.0
SSM 327						441	135.2	8.0
SSM 130H						612	247.7	15.6
SSM 230H	450	765	1130*	960	5096	794	367.4	20.1
SSM 330H						630	209.1	15.7
SSM 136H						904	321.1	30.6
SSM 236H	375	640	950*	1803	6801	1184	514.4	46.0
SSM 336H						1826	697	61.4
SSM 436H						892	308	30
SSM 142						1239	543	58
SSM 242	325	545	805*	2098	7997	1680	601	76
SSM 342						1432	499	75
SSM 148						2132	881	141
SSM 248	275	475	705*	3550	13500	2966	1338	208
SSM 348						4288	1164	298
SSM 260						5281	1755	448
SSM 360	225	380	575*	8407	29300	6577	2585	635
SSM 460								

Air Tube Disc Clutches and Brakes

Spring-Set Brakes (Sizes 4H, 8-36)

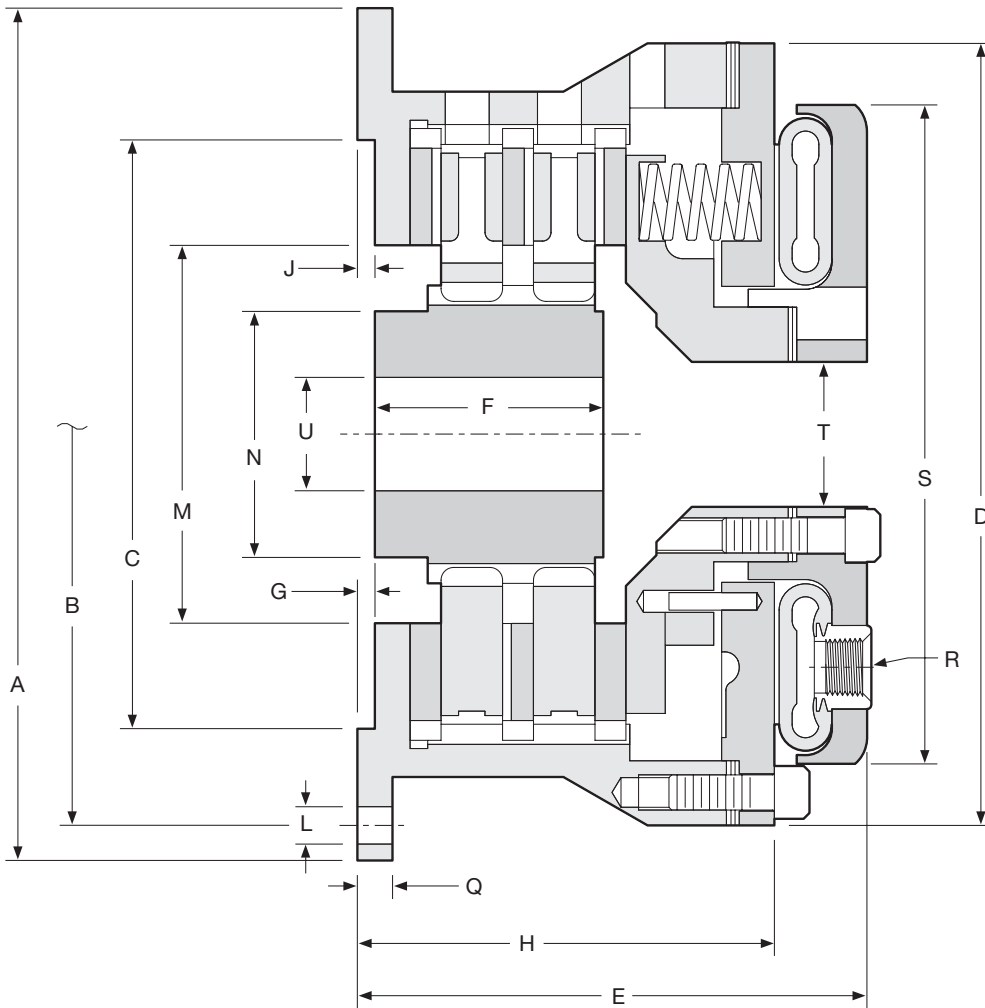

Air Tube Disc Clutches and Brakes

Dimensions: mm

Model Size ATD-	A	B Hole Circle	C ⁽¹⁾ Pilot	D	E	F	G	H
SSM 104H	180	165	140	180	105	25	1.6	96
SSM 108					149.4	50.8		115.8
SSM 208	308.1	282.58	220	282.7	182.6	82.6	6.4	150.9
SSM 111					166.6	69.9	3.3	138.2
SSM 211	406.4	374.65	295	374.7	217.4	111.3	6.4	184.2
SSM 114					203.2	76.2	3.3	152.4
SSM 214	476.3	444.50	370	444.5	251.2	114.3	9.7	198.4
SSM 314					297.7	165.1	9.7	246.1
SSM 116					209.6	101.6		152.4
SSM 216	539.8	508.00	410	508.0	255.5	120.7	9.7	199.9
SSM 316					308.1	168.4		251.0
SSM 118					228.6	101.6	11.2	166.6
SSM 218	590.6	558.80	470	558.8	271.8	120.7	11.2	214.6
SSM 318					—	—	—	—
SSM 121					241.6	101.6	19.1	187.5
SSM 221	685.8	647.70	540	632.0	301.8	130.3	19.1	243.1
SSM 321					—	—	—	—
SSM 124H					242.8	101.6	19.1	165.1
SSM 224H	762	730.25	620	736.6	301.8	130.3	20.6	241.3
SSM 324H					—	—	—	—
SSM 127					252.5	114.3		195.3
SSM 227	831.9	800.10	700	787.4	317.5	174.8	19.1	257.3
SSM 327					387.4	201.7		319.0
SSM 130H					279.4	127.0	16	211.1
SSM 230H	939.8	901.70	775	882.7	374.7	181.1	47.8	298.5
SSM 330H					—	—	—	—
SSM 136H					298.5	108.0	16	217.4
SSM 236H	1104.9	1066.80	925	1041.4	384.3	228.6	16	304.8
SSM 336H					484.1	314.5	25.4	401.6

⁽¹⁾ Dimension "C" is given as a nominal figure. The applicable tolerance is ISO H7. (Consult factory for drawing before final layout.)

Dimensions: mm

Model Size ATD-	J	L No. - Size	M	N	Q	R		S	T	U	
						No. -	Size			Min.	Max.
SSM 104H	4.7	4 - Ø9	76	50	54	2 -	1/8 NPT	180	50	15	25
SSM 108	6.4	6 x Ø18	136.7	88.9	12.7	2 -	1/2 NPT	238.3	52.3	25	50.8
SSM 111	9.7	8 x Ø18	177.8	101.6	16	2 -	1/2 NPT	303.3	76.7	25	63.5
SSM 114											
SSM 214	9.7	8 x Ø18	239.8	139.7	16	2 -	1/2 NPT	365.3	98	35.1	88.9
SSM 314											
SSM 116											
SSM 216	9.7	12 x Ø18	266.7	152.4	16	2 -	1/2 NPT	414	111.3	35.1	101.6
SSM 316											
SSM 118	9.7										
SSM 218	9.7	12 x Ø18	317.5	177.8	16	3 -	1/2 NPT	492.3	124	50.8	120.7
SSM 318											
SSM 121	7.9										
SSM 221	7.9	12 x Ø18	368.3	228.6	19.1	3 -	1/2 NPT	541.3	158.8	50.8	152.4
SSM 321											
SSM 124H	6.4										
SSM 224H	6.4	12 x Ø18	368.3	228.6	19.1	3 -	1/2 NPT	673.1	209.6	50.8	152.4
SSM 324H											
SSM 127											
SSM 227	6.4	16 x Ø18	412.8	228.6	19.1	3 -	1/2 NPT	685.8	209.6	63.5	165.1
SSM 327											
SSM 130H	6.4										
SSM 230H	6.4	18 x Ø22	489	254	19.1	4 -	1/2 NPT	811.3	209.6	63.5	184.2
SSM 330H											
SSM 136H											
SSM 236H	6.4	18 x Ø22	600.2	304.8	22.4	4 -	1/2 NPT	971.6	323.9	152.4	228.6
SSM 336H											

(Consult factory for drawing before final layout.)

Air Tube Disc Clutches and Brakes

Spring-Set Brakes (Sizes 6, 42-48)

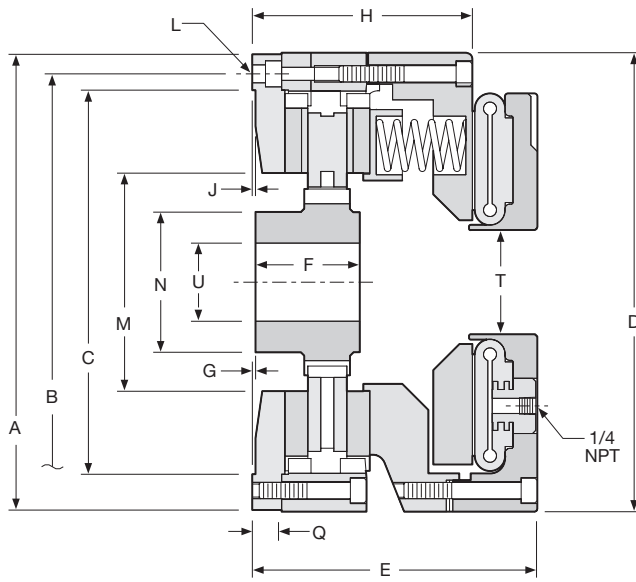

Size 6

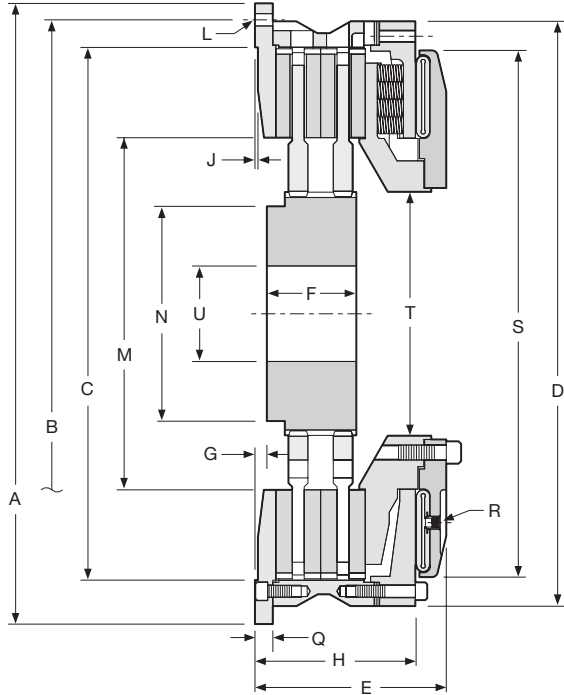

Sizes 42-48

Air Tube Disc Clutches and Brakes



Dimensions: mm

Model Size ATD-	A	B Hole Circle	C ⁽¹⁾ Pilot	D	E	F	G	H
SSM 106					138.9	50.8	0.0	107.2
SSM 206	222.3	203.20	190	223.8	169.2	82.6	1.5	138.2
SSM 142					311.9	143.0	25.40	246.1
SSM 242	1320.8	1250.95	1070	1244.6	407.2	190.5		341.4
SSM 148					381.0	152.4	0.0	284.2
SSM 248	1549.4	1473.20	1220	1441.5	491.0	222.3	25.4	393.7
SSM 260 ⁽²⁾					566.7	238.3	6.40	447.3
SSM 360 ⁽²⁾	1790.7	1689.10	1600	1790.7	682.8	358.9		565.2

⁽¹⁾ Dimension "C" is given as a nominal figure. The applicable tolerance is ISO H7. (Consult factory for drawing before final layout.)

Dimensions: mm

Model Size ATD-	J	L No. - Size	M	N	Q	R		S	T	U	
						No. -	Size			Min.	Max.
SSM 106		4 x Ø9				2 -	1/4 NPT	—	50.8	15.2	50.8
SSM 206	1.5		106.4	68.3	14.2						
SSM 142		24 x Ø26				4 -	1/2 NPT	1102.9	519.2	203.2	355.6
SSM 242	6.4		749.3	457.2	26.9						
SSM 148		24 x Ø26				4 -	1/2 NPT	1324.1	482.6	254.0	457.2
SSM 248	6.4		812.8	654.1	38.1						
SSM 260 ⁽²⁾		24 - 4.5" NC				6 -	1/2 NPT	1562.1	524.0	279.4	482.6
SSM 360 ⁽²⁾	6.4		914.4	685.8	—						

⁽²⁾ Less backplate.

(Consult factory for drawing before final layout.)

Tension Brakes

Mistral Tension Brakes



Wichita Mistral pneumatic tension brake is attuned to the needs of the corrugating market for which it was originally designed. It is also a versatile product which is finding

favour in additional tensioning applications. Wichita designers and engineers consulted extensively with mill roll stand manufacturers and users to offer a tension

brake ideally suited to the needs of this particular market. The result is a compact, high performance, versatile brake capable of handling the tensioning needs of the latest machine designs, as well as existing equipment. The Mistral paves the way for increasing line speeds by 164 cm/sec. from 810 ft./min. (or slower) to 1,140 ft./min.



Mounting Ease

Three bolts mount the brake to the arm of the mill roll stand or machine frame and an optional pilot location makes fitting to both new and existing machines a simple operation.

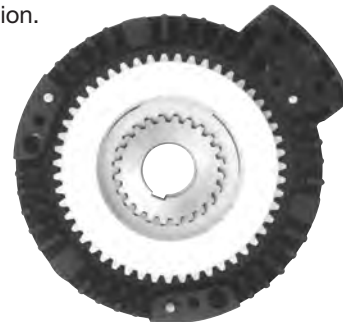

Wear Indicator

A brake wear indicator, which is conveniently located for easy visual inspection, means no down time to check remaining friction material life.

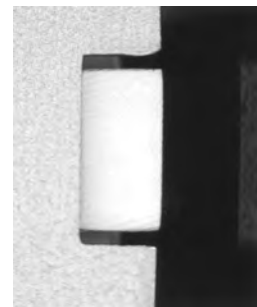

Easy Connection

Air and electrical connections are easily accessible for fast, simple installation and maintenance.

Compact Design, Modern Styling

Mistral brakes are compact at only 29.46mm or 40.89mm in diameter. Their size facilitates the pickup of small, part reels used in short batch runs. For automatic reel loading machines, Mistral offers optional infrared and speed sensor installation within the brake. Their modern, industrial styling enhances the appearance of any machine on which they are used.

Fine Tuning

Each brake may be specified with a varying number of pneumatic actuators, allowing precise selection of brake torque capacity for optimum tension control.

Safety

Mistral's integral guarding eliminates the cost and effort of installing external guards. Operator safety is further enhanced by automatic air and electric disconnects when the front cover is removed.



Front Cover Removal

By removing just three cap screws, the Mistral's front cover can be detached for easy and fast access to internal parts. Cover removal automatically disconnects both air and electricity.

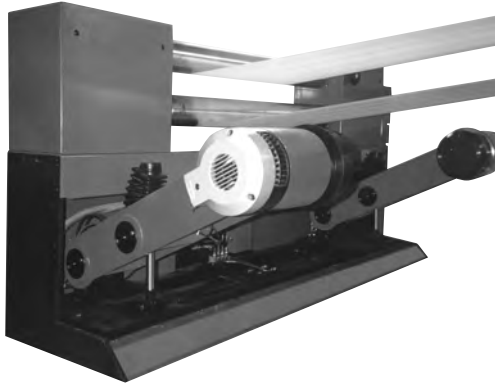

Integral Cooling

A rugged, high performance, low energy usage fan is housed within the brake for high heat dissipation - a must for increased productivity through controlled tension at many roll speeds.

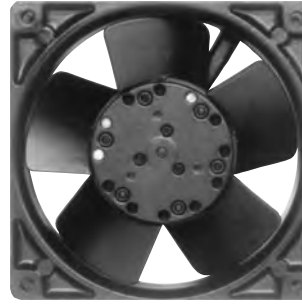

B

Fan Data and Connection Data

Model	Fan Voltages	Fan Power	Electric	Pneum.
200	220 VAC or/order	20W	M16	1/8 BSP
	110 VAC or/order		PG9	1/8 BSP
	24 VDC		3/8 NPT	1/8 NPT
280	220 VAC or/order	18W	M16	1/8 BSP
	110 VAC or/order		PG9	1/8 BSP
	24 VDC		3/8 NPT	1/8 NPT

Performance Curve

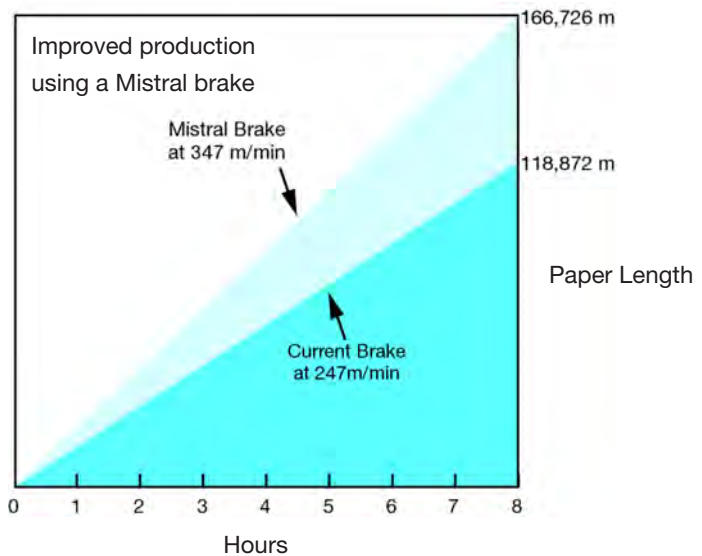

Wichita Tension Products - order or see Tension Control Systems Catalogue

From the air cooled Modevo to the renowned Kopper Kool range, Wichita have a brake to suit all tension control duties in converting applications. For optimum control, including flying splice operations, we offer the modular Altra range of tension controllers. Please contact your Wichita representative to find out more and to request a copy of our Tension Control Systems catalogue, or visit wichita.co.uk and look at our product range, then choose Tension Products.



Altra Sonic



Altra Steady



Altra Easy

Tension Brakes | Air Cooled

ModEvo Tension Brakes

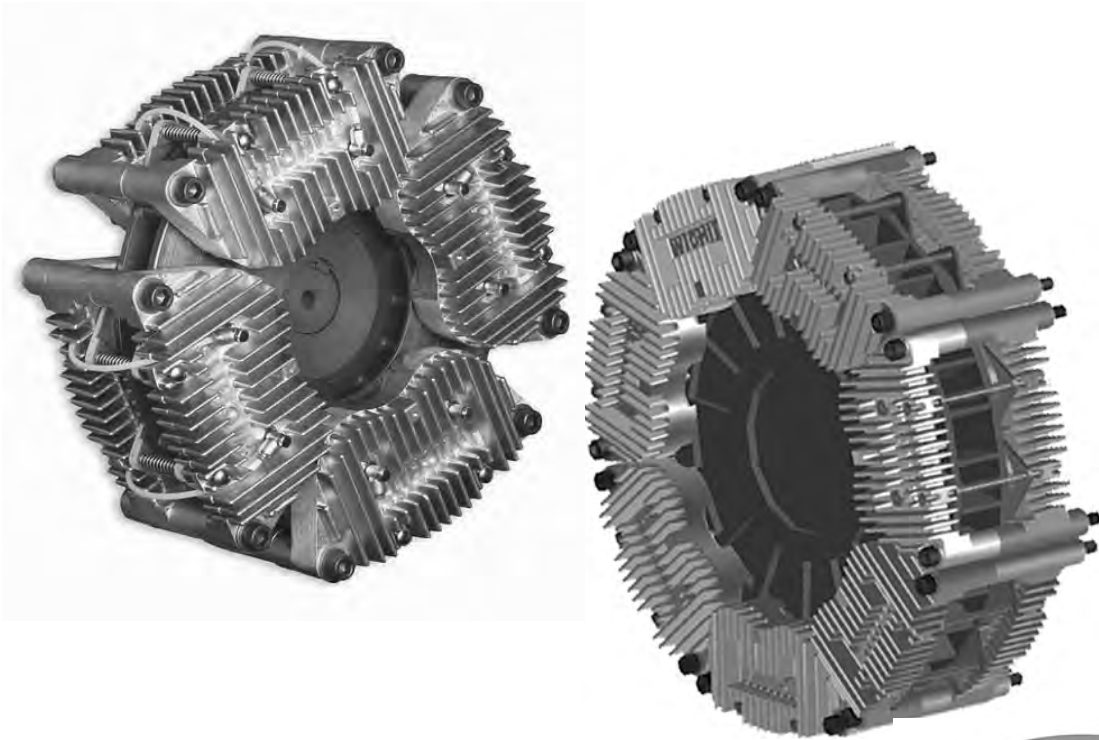

Brake Discs and Cooling

The ModEvo brake disc was developed at the Bedford, UK factory using Finite Element Analysis techniques to ensure maximum strength with minimum weight. The design is optimized to make best use of the cooling air available at slow speeds, and being bidirectional, it achieves high heat dissipation capacity in either rotational direction. An optional electric cooling fan is available where space is limited or more extreme heat handling is required.

Available in five sizes: 250 mm, 300 mm, 350 mm, 400 mm and 450 mm diameters, all discs are the same thickness and use the same brake modules and actuators. Each disc can be specified with a minimum of a single module, up to the maximum number of modules that can be fitted around the disc. This allows torque-

handling capabilities ranging from a maximum of 893 Nm for the 250 mm disc, up to 4313Nm for the 450 mm disc.

NOTE: If using a high speed ductile iron disc the catalog heat rating should be reduced by 10% as the thermal conductivity of the ductile iron is less than grey cast iron.

Maximum Rotational Speed		
Disc Diameter mm	Standard Speed rev./min.	High Speed rev./min.
250	2,250	3,375
300	1,900	2,850
350	1,650	2,475
400	1,450	2,175
450	1,250	1,875

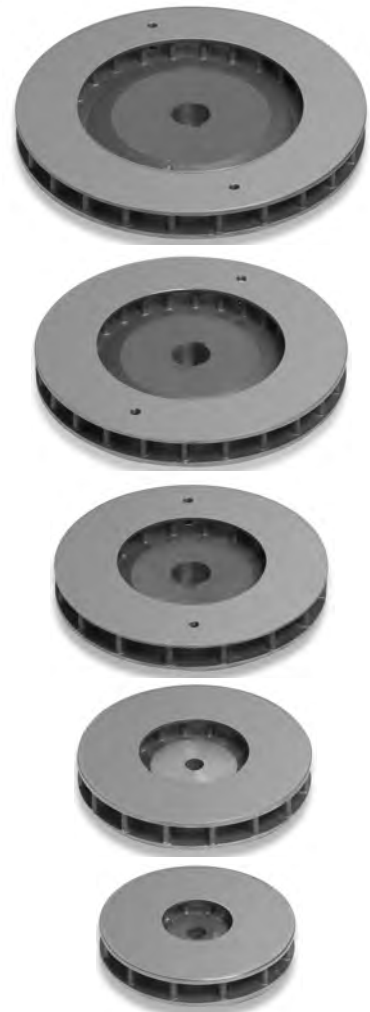

Actuator Options

Newly developed rolling diaphragm actuators are used in ModEvo, producing more force than previous designs to allow higher torque ratings. However, the sensitivity for which rolling diaphragms are favoured is not compromised. Three actuator options are available, offering clamping forces of 100%, 60% or 25%.

The finned, die cast aluminum brake module is common to all brake disc diameters. Each module houses two pairs of actuators, and allows friction pads to be changed quickly without dismantling the module.



100%



60%



25%

Friction Pad Options

To provide maximum flexibility when selecting the required torque/tension range for an application, two pad options are available, with different coefficients of frictions: Low ($\mu=0.22$), and Standard ($\mu=0.3$). Pad types may be mixed within a single brake assembly to provide an exact match to the machine requirements.



ModEvo 300/8 with Fan



Brake Size (fan Diameter)	24v DC	115v AC	230v AC
250 (150 mm)	Yes	Yes	Yes
300 (150 mm)	Yes	Yes	Yes
350 (150 mm)	Yes	Yes	Yes
400 (150 mm)	Yes	Yes	Yes
(200 mm)	not available	Yes	Yes
450 (150 mm)	Yes	Yes	Yes
(200 mm)	not available	Yes	Yes
(250 mm)	not available	Yes	Yes

Optional Guard

The optional guard has a plastic front with 'ModEvo' molded in and a metal ventilated perimeter.

Mounting is by four brackets on customer's machine frame.

Other low cost guards are also available.

The centre of the guard is designed such that it may be cut-out by customer to suit the diameter of the shaft in through-shaft installations.

The mesh guard below is designed to fit the Modevo 250mm and 350mm. It has a sturdy welded steel construction.



B

Standard Vent Clutches

Coupling Clutches

The Wichita Standard Vent Combination Clutch-Coupling is designed for reliable in-line power transmission. The simple air-tube design, with small air volume, speeds engagement and disengagement. It is unaffected by centrifugal force and has no self-energization like drum clutch designs. Ideally suited for large inertia loads where smooth controlled starts are needed.

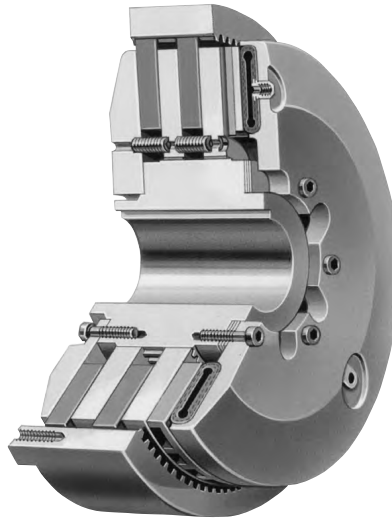

Grinding Mill Clutches

Wichita Grinding Mill Clutches are specially designed to provide quick, smooth starts with limited current surge for heavy duty grinding mills. The clutch is adaptable to remote control allowing centralized operation through simple air or electric circuits.

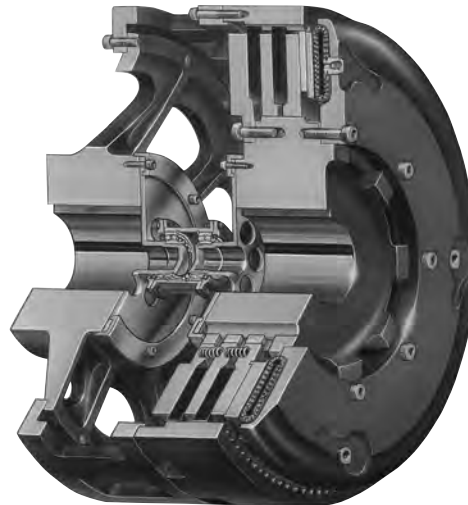

Marine Clutches

The Wichita Marine Standard Vent Combination Clutch-Coupling is designed for reliable in-line power transmission. The simple air-tube design, with small air volume, speeds engagement and disengagement.

It is unaffected by centrifugal force and has no self-energization like drum clutch designs. Ideally suited for large inertia loads where smooth controlled starts are needed.

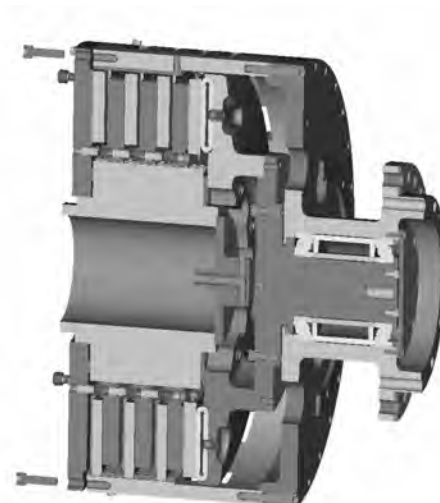

Typical Applications

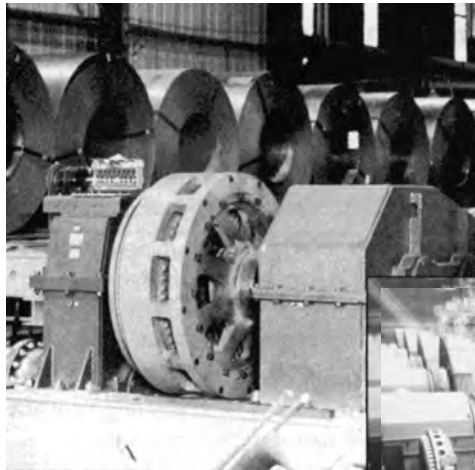

Wichita Standard Vent Clutches allow smooth acceleration of coil transporter.

Reliable, trouble-free Wichita Standard Vent Clutches handle maximum loads on drilling rigs.

Wichita Grinding Mill Clutches provide shock-free start-up of large inertia loads.



Application Guidelines

Clutch selection is made by knowing the application horsepower/100 RPM, the available air pressure, required torque and

the clutch heat horsepower. The Requirements Table (Chart A) gives application factors ranging from light duty (the A group) to extra heavy duty (the D group).

Chart A

Field of Application	Group A	Group B	Group C	Group D
Pumps		Centrifugal compressors	Reciprocating compressors over 2 cylinders, centrifugal fans & blowers	Reciprocating compressors one or two cylinders
Agitators	Liquid	Semi-solid	Solids	
Brick manufacturing			Brick press, extruder, pug mill	
Can & bottling machine		Bottle-can feeders, filling, mixers		
Engine driven equipment			Crane, hoist, engine	Crowd
Grinding mills			Ball-rod-sag-pebble	Crushers, shakers
Lumber processing		Yarder	Carriages, conveyers	Chipper, logger
Marine		Propulsion clutch, anchor winch	Shaft brakes, propulsion reversing type	
Bulk material handling	Conveyors evenly loaded, line shaft evenly loaded	Feeders	Elevators	
Metal production & metalforming		Coilers, slitters, press brake, non-g geared press, geared press	Draw bench, rolling mill, shear, back geared press, deep draw press, transfer press, toggle press	Hammer mill, forming press, forging press, header press, knuckle press
Paper industry dryer sections & calenders consult factory			Fourdrinier to 500 FPM, paper mill plane & smoothing press	Fourdrinier to 1800 RPM press selections, calenders & dryers
Petroleum production		Drilling & service rig master clutches, compound clutches, rotary, drum		Mud pumps, PTO clutches
Rubber manufacturing	Transfer machines evenly loaded		Banberry mixer, drum mixer, extruder, calender	Centrifuge



Standard Vent Clutches

Coupling and Grinding Mill Clutch Selection

Specifications

Chart C

Model Size ATD-	Dynamic Slip Torque capacity Nm ⁽¹⁾	Maximum speed RPM ⁽²⁾		Weights and Inertia						Airtube Displacement Volume cm ³	
				Total Unit		External Parts		Standard Parts			
				@5.5 bar / @8.5 bar	Std performance	High performance	Weight (kg)	Inertia (kg m ²)	Weight (kg)	Inertia (kg m ²)	Weight (kg)
SV 108	620 - 960	1750	2500	16	0.103	3.6	0.05	8	0.625	55	300
SV 208	1240 - 1920	1750	2500	26	0.155	8	0.074	8	32	55	300
SV 308	-	1750	2500	-	-	-	-	-	-	55	300
SV 111	1400 - 2170	1400	2200	30	0.458	8.6	0.21	19	0.3	90	500
SV 211	2800 - 4340	1400	2200	49	0.715	16	0.43	19	0.3	90	500
SV 311	-	1400	2200	-	-	-	-	-	-	90	500
SV 114H	2435 - 3765	1200	2000	68	1.55	15	0.575	35	0.775	125	700
SV 214H	4870 - 7530	1200	2000	93	1.98	26	0.985	35	0.775	125	700
SV 314H	7305 - 11295	1200	2000	118	-	37	-	35	0.775	125	700
SV 116	3360 - 5190	1200	2000	85	2.53	19	0.945	43	0.863	160	920
SV 216	6720 - 10380	1200	2000	124	3.65	41	1.93	43	0.863	160	920
SV 118	5705 - 8815	1000	1750	125	3.93	21	1.35	72	1.7	250	1400
SV 218	11410 - 17630	1000	1750	176	6.15	42	2.7	72	1.7	250	1400
SV 118H	-	-	-	-	-	-	-	-	-	-	-
SV 218H	-	-	-	-	-	-	-	-	-	-	-
SV 318H	-	-	-	-	-	-	-	-	-	-	-
SV 221	15510 - 23970	900	1400	260	11.2	62	5	100	2.5	300	1600
SV 321	23265 - 35955	900	1400	360	16.3	100	7.43	100	2.5	300	1600
SV 124H	13575 - 20980	700	1100	244	14.6	41	4.15	109	3.08	490	2600
SV 224H	27150 - 41960	700	1100	343	22.4	82	8.2	109	3.08	490	2600
SV 324H	40725 - 62940	700	1100	470	27.9	130	13.3	109	3.08	490	2600
SV 227	30520 - 47170	700	1100	420	29.5	84	10.1	170	10	400	2600
SV 327	45780 - 70755	700	1100	540	39	132	15.8	170	10	400	2600
SV 230H	59260 - 91590	600	1000	624	55.4	130	19.6	250	19.5	960	5100
SV 330H	88890 - 137385	600	1000	860	80	254	38.8	250	19.5	960	5100
SV 336	134760 - 208275	560	800	1281	141	285	41.3	400	50	1800	6800
SV 342	192480 - 297480	460	900	1620	316	487	138	520	112.5	2100	8000
SV 248	237600 - 367200	400	600	2152	495	445	171	900	132.5	3550	13500
SV 348	356400 - 550800	400	600	3500	775	520	420	900	132.5	3550	13500
SV 260	473000 - 731000	340	475	3150	1013	592	325	-	-	8400	29300
SV 360	709000 - 1096000	340	475	4850	1450	570	355	-	-	8400	29300
SV 460	946000 - 1462000	340	475	-	-	-	-	-	-	8400	29300
SV 560	-	340	475	-	-	-	-	-	-	-	-
SV 372	1204500 - 1861500	265	400	-	-	-	-	-	-	-	-

⁽¹⁾ Torque Rating - Dynamic torque ratings represent the full clutch capacity. Service conditions vary but as a guide to selection for cycling application use 75% of torque rating. Air Pressure - torque is directly proportional to the air pressure supplied.

⁽²⁾ High Speed - maximum speed ratings may be exceeded in many applications. For advice on speed, service factors etc. consult your Wichita Engineer. Consult factory for drawing before final layout.

Note: Maximum air pressure – 7 BAR



Standard Vent Clutches - Driving Adapters

Quick Change Adapters

The quick change feature, using a driving elbow piece between the driving adapter and the clutch driving ring, enables replacement of any wearing clutch part without disturbing either shaft.

Standard Driving Adapters

The driving adapter is designed to allow the clutch to be used in a shaft-to-shaft or through-shaft coupling arrangement.

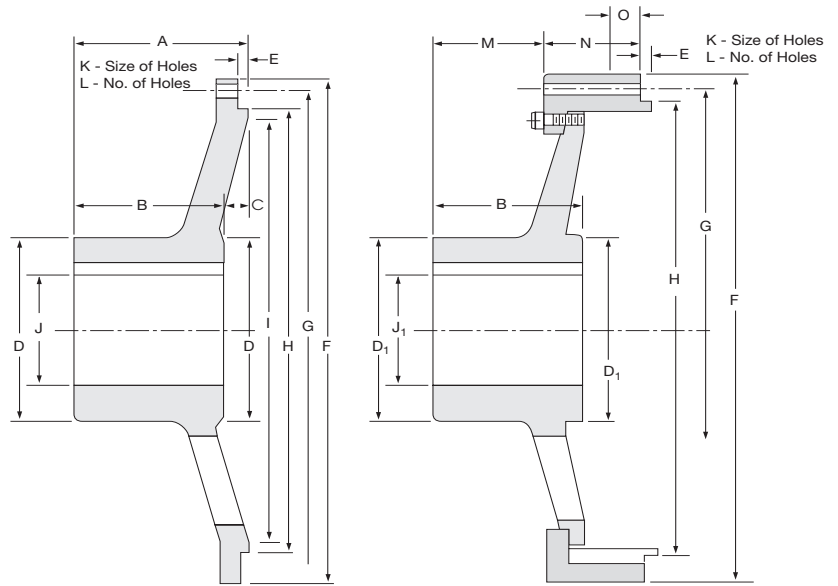

Standard Adapter (Standard Gap)

Quick Change Adapter (Access Gap)

Dimensions: mm

Size	A	B	C	D	D ₁	E	F	G	H
8	79.375	76.2	3.175	95.25	—	3.175	263.525	244.475	225.2726
11	92.075	82.55	9.5	158.75	127	3.175	14.375	365.125	314.2234
14H	136.525	120.65	403	177.8	158.75	6.35	444.5	412.75	384.0734
18	174.625	146.05	28.6	203.2	203.2	9.525	558.8	527.05	495.1984
18H	174.625	146.05	28.6	203.2	203.2	9.525	558.8	527.05	495.1984
21	171.45	152.4	19.05	241.3	228.6	6.35	635	603.25	571.3984
24H	212.725	186	27	254	304.8	6.35	711.2	679.45	647.573
27	222.25	196.85	25.4	279.4	292.1	6.35	787.4	755.65	723.773
30H	234.95	222.25	12.7	355.6	355.6	6.35	863.6	831.85	799.973
36	266.7	254	12.7	381	355.6	6.35	1041.4	1009.65	977.773
42	279.4	254	25.4	381	381	6.35	1250.95	1200.15	1142.873
48	—	346.075	—	—	508	12.7	1422.4	1371.6	1290.32
60	—	412.75	—	609.6	—	9.525	1695.45	1644.65	1593.85

Size	I	Max. Bore Rect. Key J	J ₁	K	L	M	N	O
8	212.725	63.5	—	13.4874	152.4	47.625	*	—
11	298.45	104.902	85.725	16.6624	203.2	50.8	63.5	—
14H	368.3	120.65	104.775	16.6624	152.4	53.975	79.375	—
18	469.9	133.35	133.35	17.4752	152.4	111.125	88.9	—
18H	469.9	133.35	133.35	17.4752	152.4	111.125	88.9	—
21	552.45	158.75	152.4	17.4752	152.4	101.6	158.75	—
24H	622.3	168.402	168.275	17.4752	152.4	131.7752	139.7	—
27	692.15	184.15	193.675	17.4752	304.8	141.3002	117.475	—
30H	774.7	234.95	234.95	17.4752	304.8	165.1	146.05	—
36	952.5	254	234.95	17.4752	406.4	200.025	104.775	—
42	1117.6	254	254	26.1874	304.8	188.9252	144.4752	—
48	—	—	254	26.1874	304.8	257.175	155.575	—
60	—	457.2	—	26.1874	609.6	311.15	292.1	63.5

* Consult Factory

Standard Vent Clutches

Coupling and Grinding Mill Clutches

Component Parts

- | | |
|------------------|----------------------------------|
| 1. Hub | 7. Release Spring |
| 2. Hex Head Bolt | 8. Center Plate |
| 3. Backplate | 9. Pressure Plate |
| 4. Shim | 10. Hose Assembly |
| 5. Driving Ring | 11. Air Tube |
| 6. Friction Disc | 12. Air Tube Holding Plate |
| | 14. Socket Head Capscrew |
| | 16. Elbow |
| | 17. Bolt (Furnished by customer) |

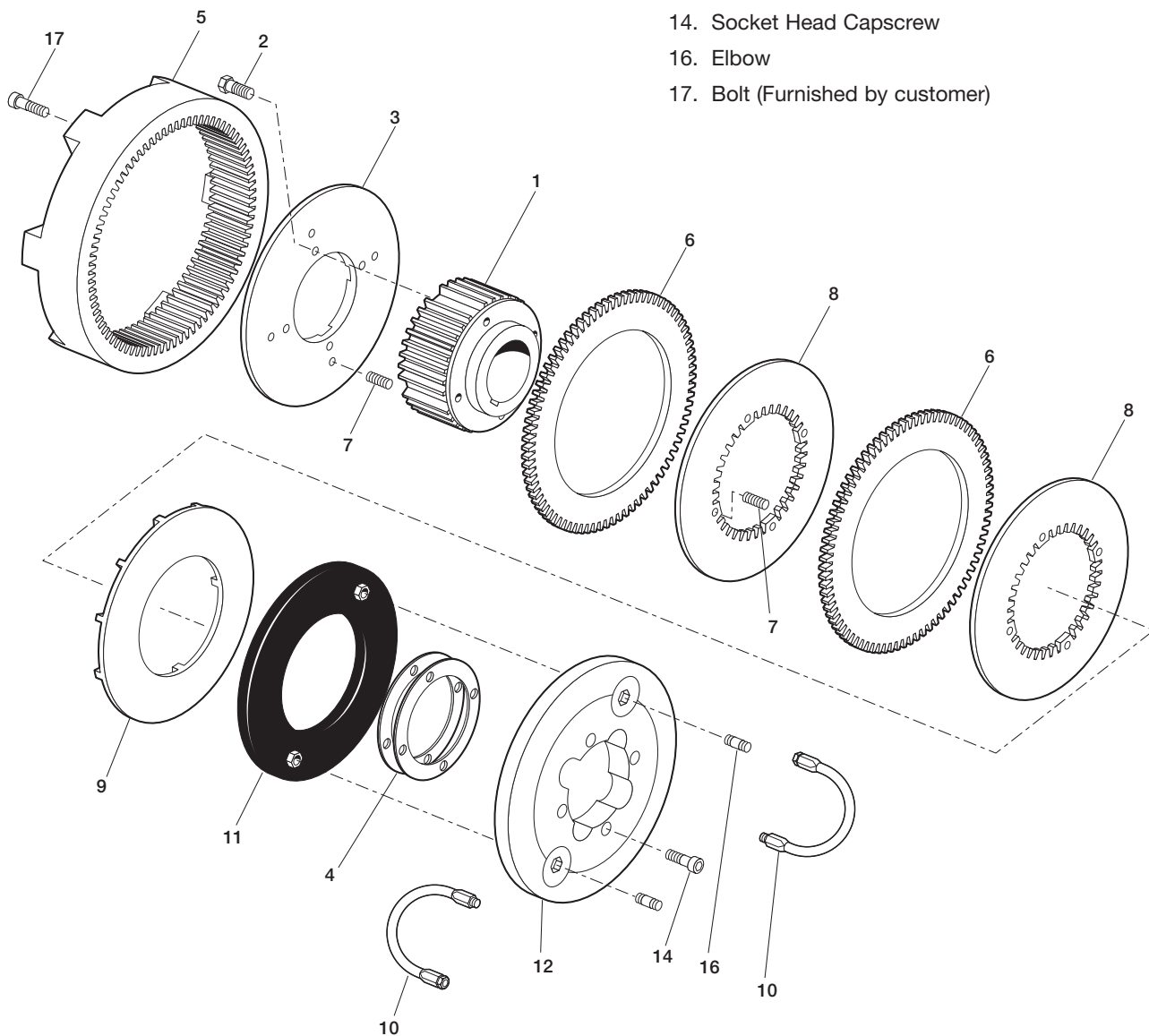

Coupling Clutches

- **In-line power applications**
- **Smooth, controlled acceleration**
- **Unaffected by centrifugal force**

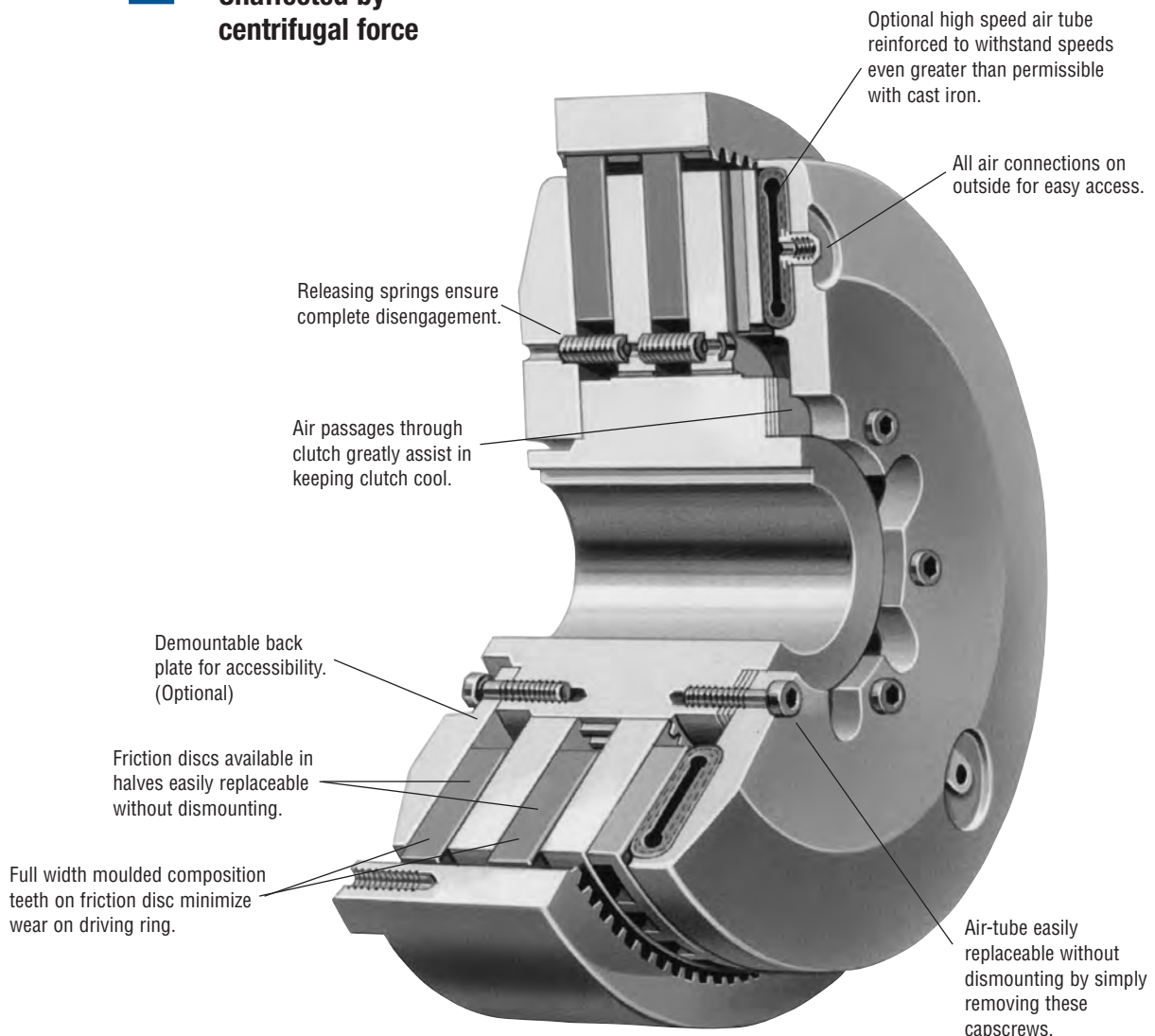

C

The Wichita Standard Vent Combination Clutch-Coupling is designed for reliable in-line power transmission. The simple air-tube design, with small air volume, speeds engagement and disengagement. It is unaffected by centrifugal force and has no-self-energization like drum clutch designs. Ideally suited for large inertia loads where smooth controlled starts are needed.

The Wichita air-tube disc design combines all the best features of a disc type clutch with all the advantages of direct air engagement.

The compact design, capable of smoothly engaging and disengaging, employs the simplest and most trouble-free method of applying air pressure yet designed.

Standard Vent Clutches

Coupling Clutches

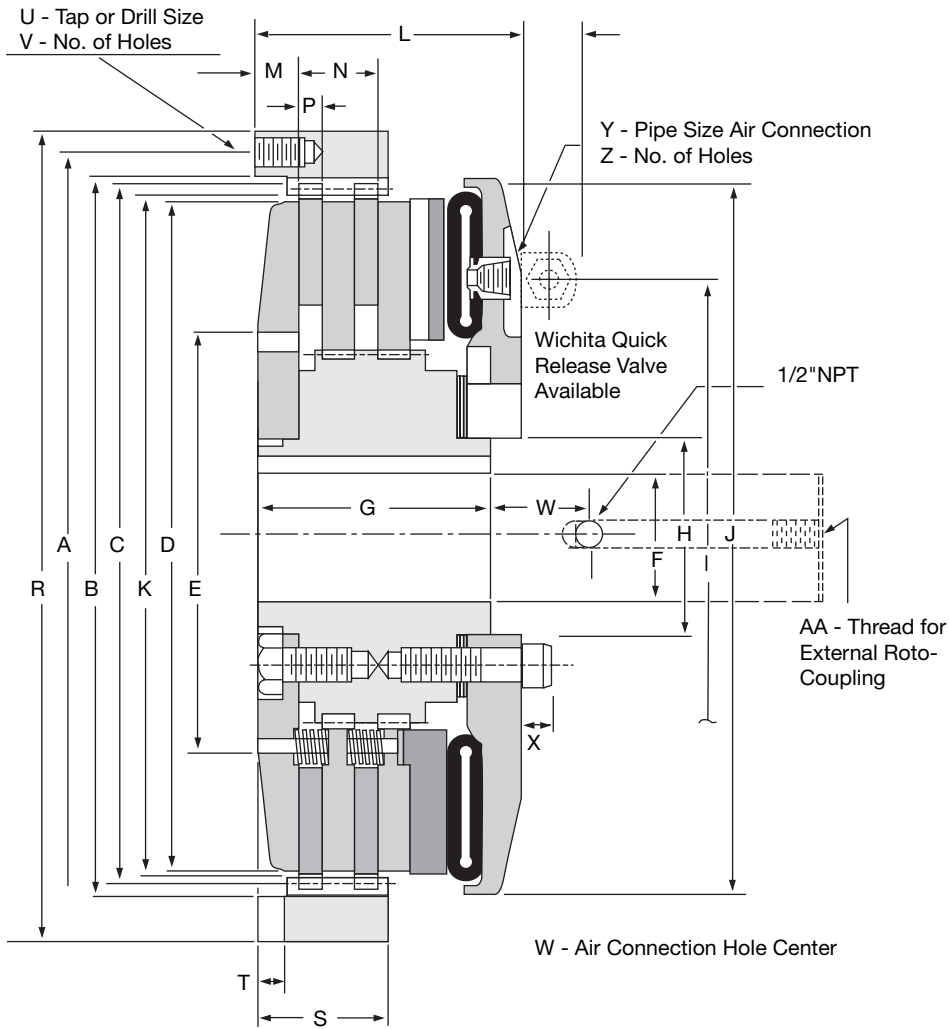

⁽¹⁾ Dimension "C" is given as a nominal figure. The applicable tolerance is ISO H7. (Consult factory for drawing before final layout.)

Standard Vent Clutches

Dimensions: mm (Consult factory for drawing before final layout.)

Model Size ATD-	Max Bore Rect. Key									
	A	B	C	D	E	F	G	H	I	J
108 SV	244	225.5	215.9	203.2	203.2	49	69.85	49	168.27	244
208 SV	244	225.5	215.9	203.2	203.2	49	104.77	49	168.27	244
308 SV	244	225.5	215.9	203.2	203.2	49	139.7	49	168.27	244
111 SV	340	314.4	304.8	279.4	279.4	75	76.2	76	215.9	303
211 SV	340	314.4	304.8	279.4	279.4	75	107.95	76	215.9	303
311 SV	340	314.4	304.8	279.4	279.4	75	141.3	76	215.9	303
114H SV	413	384.25	372.6	355.6	238.12	83	109.5	115	317.5	413
214H SV	413	384.25	372.6	355.6	238.12	83	146.05	115	317.5	413
314H SV	413	384.25	372.6	355.6	238.12	83	182.57	115	317.5	413
118 SV	527	495.4	476.25	457.2	292.1	90	120.65	133	355.6	492
218 SV	527	495.4	476.25	457.2	292.1	90	158.75	133	355.6	492
118H SV	527	495.4	476.25	457.2	292.1	90	120.65	133	406.4	549
218H SV	527	495.4	476.25	457.2	292.1	90	158.75	133	406.4	549
318H SV	527	495.4	476.25	457.2	292.1	90	196.85	133	406.4	549
321 SV	527	571.5	552.45	533.4	355.6	115	231.77	178	406.4	549
124H SV	679	571.5	628.65	533.4	406.4	115	149.22	178	533.4	686
224H SV	679	571.5	628.65	533.4	406.4	115	184.15	178	533.4	686
324H SV	679	571.5	628.65	533.4	406.4	115	238.12	178	533.4	686
327 SV	679	724	704.85	685.8	495.3	190	247.65	229	533.4	686
230H SV	832	800.1	781.05	762	571.5	152	215.9	229	628.65	822
330H SV	832	800.1	781.05	762	571.5	152	292.1	229	628.65	822
336H SV	1010	978	952.5	914.4	711.2	229	320.67	343	774.7	972
342 SV	1200	1143	1117.6	1066.8	1066.8	254	301.62	533	889	1121
248 SV	1372	1320.8	1295.4	1219.2	889	305	276.22	533	1016	1305
348 SV	1372	1320.8	1295.4	1219.2	889	305	346	533	1016	1330
260 SV	1645	1594	1574.8	1524	917.6	-	412.75	575	1181.1	1562
360 SV	1645	1594	1574.8	1524	917.6	-	508	575	1181.1	1562
460 SV	1645	1594	1574.8	1524	917.6	-	596.9	575	1181.1	1562

⁽¹⁾ Dimension "C" is given as a nominal figure. The applicable tolerance is ISO H7. (Consult factory for drawing before final layout.)

Model Size ATD-	K	L	M	N	P	R	S	T	U	V	W	X	Y	Z
	108 SV	210	102	19.05	—	11.12	264	35	12.7	6xM12	6	57.1	12.7	1/2
208 SV	210	137	19.05	44.4	11.12	264	70	12.7	6xM12	6	57.1	12.7	1/2	50.8
308 SV	210	168	19.05	77.8	11.12	264	38	12.7	6xM12	6	57.1	12.7	1/2	50.8
111 SV	299	102	22.225	—	12.7	365	38	12.7	8xM16	8	63.5	11.12	1/2	50.8
211 SV	299	138	22.225	44.4	12.7	365	73	12.7	8xM16	8	63.5	11.12	1/2	50.8
311 SV	299	171	22.225	76.2	12.7	365	107	12.7	8xM16	8	63.5	11.12	1/2	50.8
114H SV	367	129	28.575	—	15.87	445	48	15.8	6xM16	6	57.1	19.05	1/2	50.8
214H SV	367	165	28.575	50.8	15.87	445	83	19	6xM16	6	57.1	19.05	1/2	50.8
314H SV	367	203	28.575	85.7	15.87	445	120	19	6xM16	6	57.1	19.05	1/2	50.8
118 SV	477	143	33.3502	—	15.87	559	49	19	6xM16	6	62	25.4	1/2	76.2
218 SV	477	181	33.3502	53.9	15.87	559	89	19	6xM16	6	62	25.4	1/2	76.2
118H SV	477	143	33.3502	—	15.87	559	49	19	6xM16	6	62	25.4	1/2	76.2
218H SV	477	185	33.3502	53.9	15.87	559	89	19	6xM16	6	62	25.4	1/2	76.2
318H SV	477	221	33.3502	95.2	15.87	559	130	19	6xM16	6	62	25.4	1/2	76.2
321 SV	543	257	41.275	107.9	19.05	635	159	25	6xM16	6	60.3	25.4	1/2	76.2
124H SV	618	167	41.275	—	22.22	711	72	19	6xM16	6	69.8	25.4	1/2	76.2
224H SV	618	221	41.275	69.8	22.22	711	114	19	6xM16	6	69.8	25.4	1/2	76.2
324H SV	618	264	41.275	117.5	22.22	711	159	19	6xM16	6	69.8	25.4	1/2	76.2
327 SV	696	265	41.275	117.5	22.22	787	165	35	12xM16	12	60.3	25.4	1/2	76.2
230H SV	771	257	41.275	95.2	31.75	864	143	35	12xM16	12	73	25.4	1/2	101.6
330H SV	771	327	41.275	158.7	31.75	864	206	35	12xM16	12	73	25.4	1/2	101.6
336H SV	944	365	49.2252	180.9	34.92	1041	232	38.1	12xM16	16	73	25.4	1/2	101.6
342 SV	1108	365	50.8	187.32	34.92	1251	244	38.1	12xM24	12	88.9	31.75	1/2	101.6
248 SV	1290	378	66.675	104.77	34.92	1441	219	50.8	12xM24	12	88.9	31.75	1/2	101.6
348 SV	1290	403	66.675	174.62	34.92	1422	251	50.8	12xM24	12	88.9	31.75	1/2	101.6
260 SV	1567	413	76.2	139.7	76.2	1695	229	63.5	12xM30	24	50.8	50.8	1/2	152.4
360 SV	1567	508	76.2	228.6	76.2	1695	330	63.5	12xM30	24	50.8	50.8	1/2	152.4
460 SV	1567	594	76.2	317.5	76.2	1695	419	63.5	12xM30	24	50.8	50.8	1/2	152.4

(Consult factory for drawing before final layout.)

Drum Clutches and Brakes

Based on over 50 years experience in providing solutions to demanding power transmission challenges worldwide, we are proud to offer our customers a range of replacement elements and spares for drum type clutches and brakes. Backed by the Wichita name and our 2 year guarantee, these elements are directly interchangeable with all of the popular drum elements currently in service.



DC Units showing Split Rim Construction (on left) and dual mounting

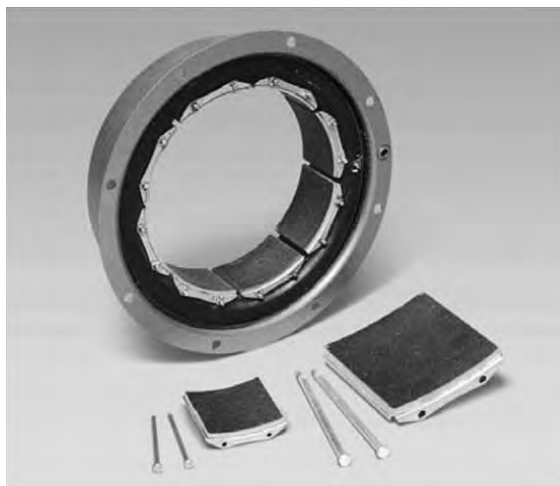

DC component parts

Wichita DC Drum Elements

The DC range of constricting drum clutch and brake is commonly found throughout all industries in general power transmission duties. Constructed using an integral rim and tube actuator and with low inertia and high misalignment capacity, the DC range offers the simplest solution to less arduous clutch and brake requirements. Along with the standard single flange mounted unit, a full range of options to suit your existing application is available. Dual flanges for back to back mounting giving double torque capacity. Multiple air inlets for increased response speed. Split construction to avoid removal of shafts on inline drives. Whether you require just the friction shoes and mounting pins, or a complete actuator and rim assembly, all are backed by the Wichita name for service and reliability.

DC Specifications

Model Size	Torque at 75psi and 100 RPM		Overall Width	Flange Diameter
	NM	Max RPM	mm	mm
DC-6-200	231	1800	74.63	273.10
DC-8-250	485	1800	87.33	327.03
DC-10-300	921	1800	104.78	390.47
DC-14-400	2226	1800	132.56	498.48
DC-16-500	3977	1540	168.28	596.90
DC-18-500	4972	1400	168.28	647.70
DC-20-500	6056	1300	168.28	698.50
DC-22-500	7040	1220	168.28	749.30
DC-24-500	8475	1200	168.28	800.10
DC-26-525	10441	1050	176.23	863.60
DC-28-525	11977	1000	176.23	914.40
DC-30-525	13672	950	176.23	965.20
DC-40-525	23842	740	176.23	1235.08

If the size unit you are looking for is not shown in this leaflet, please ask your Wichita support office about availability.

HC Oil Immersed Clutches

Model HC Oil Immersed

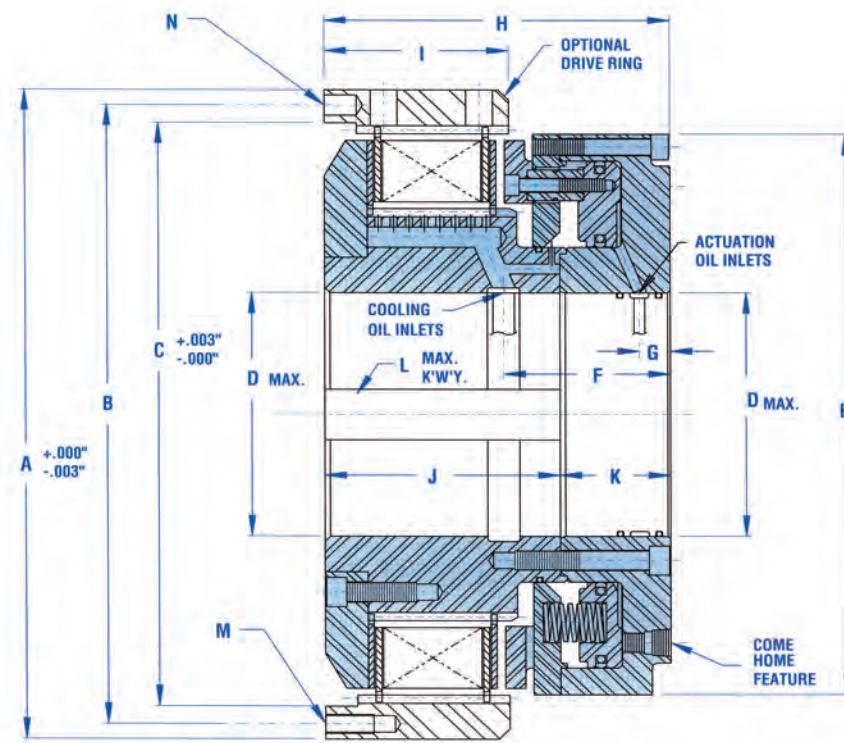

Dimensions (mm)

Clutch Model	A	B	C	D	E	F	G	H	I	J	K	L	M	N
HC-8-6	257	239.7	222	76	211	78	13	150	68.1	96.8	54.1	19	(12) - M10	(4) - 10
HC-8-8	257	239.7	222	76	211	78	13	166	83.3	111.8	54.1	19	(12) - M10	(4) - 10
HC-8-10	257	239.7	222	76	211	78	13	181	98.6	127	54.1	19	(12) - M10	(4) - 10
HC-10-6	298	281	264	102	249	81	14	157	75.4	107	49.3	25	(12) - M10	(4) - 12
HC-10-8	298	281	264	102	249	81	14	173	91.7	124	49.3	25	(12) - M10	(4) - 12
HC-10-10	298	281	264	102	249	81	14	189	108	140.2	49.3	25	(12) - M10	(4) - 12
HC-13-6	406	387.4	365	152	351	99	18	186	90	121.2	65	32	(12) - M12	(4) - 12
HC-13-8	406	387.4	365	152	351	99	18	204	109.2	139.2	65	32	(12) - M12	(4) - 12
HC-13-10	406	387.4	365	152	351	99	18	223	127.5	57.5	65	32	(12) - M12	(4) - 12
HC-15-6	467	441.3	416	165	400	95	20	213	111	145.8	66.8	38	(12) - M16	(4) - 16
HC-15-8	467	441.3	416	165	400	95	20	236	134.9	169.7	66.8	38	(12) - M16	(4) - 16
HC-15-10	467	441.3	416	165	400	95	20	260	158.8	193.8	66.8	38	(12) - M16	(4) - 16
HC-16-6	508	482.6	457	191	438	113	35	219	111	146.1	72.9	38	(12) - M16	(4) - 16
HC-16-8	508	482.6	457	191	438	113	35	243	134.9	169.9	72.9	38	(12) - M16	(4) - 16
HC-16-10	508	482.6	457	191	438	113	35	267	158.8	193.8	72.9	38	(12) - M16	(4) - 16
HC-18-6	559	527.1	495	203	473	122	38	259	147.8	181.1	77.7	38	(12) - M20	(4) - 20
HC-18-8	559	527.1	495	203	473	122	38	291	180.3	213.6	77.7	38	(12) - M20	(4) - 20
HC-18-10	559	527.1	495	203	473	122	38	324	212.9	246.1	77.7	38	(12) - M20	(4) - 20
HC-20-6	635	603.3	572	229	524	146	44	287	157.2	194.6	91.9	38	(12) - M20	(4) - 20
HC-20-8	635	603.3	572	229	524	146	44	319	189.7	227.1	91.9	38	(12) - M20	(4) - 20
HC-20-10	635	603.3	572	229	524	146	44	352	222.3	259.6	91.9	38	(12) - M20	(4) - 20

NOTES
 1) Use DXF certified drawing dimensions only for final layouts. 2) DXF and IGES files available upon request.
 3) Dimensions subject to change without notice. 4) All threaded fasteners are metric

Model HC/HCD Clutch Description

The Model HC or HCD clutches are designed to be used in either an end of shaft or through shaft mounting configuration. Their compact size makes these units ideal for incorporating within a gear housing. Multiple speed transmissions use a variety of these units to effect fixed mesh speed changes, or they may be used as a stand alone device for disconnect service.

The Model HCD clutches are provided with an internally splined outer drive ring for bolting to the user's driving or driven member. The Model HC clutches are provided without this drive ring to allow the user to spline the inside diameter of their driving or driven member which conserves radial space and provides for design compactness. All units incorporate provisions for forced oil cooling allowing high energy engagements to be made without causing thermal distress within the disc pack. Cooling oil is introduced from an external supply through axial holes provided in the shaft. Actuation pressure may come from either a pneumatic or hydraulic source. This pressure may be introduced through an axial hole provided at the shaft centre, or in the case of end shaft mounts, it may be introduced through a separate manifold.



All torque transmitting members are designed for continuous heavy duty industrial service. Hubs and drive rings are fully hardened and manufactured from high quality alloy steel forgings. Disc pack cores are designed using extra-heavy plate thicknesses to maximize torque and heat capacity. Friction materials and grooving patterns are designed to provide for high thermal and smooth engagement performance. All of the Model HC and HCD clutches contain friction materials which allow for controlled slip operation in those applications requiring this feature.

Marine main propulsion forward/reverse or disconnect service, winch disconnects, conveyor or mill soft-starts, and multi-speed transmissions are but a few of the applications for the model HC/HCD oil immersed clutches.

Operational Data

Clutch Model	Static Torque (Nm)	Dynamic Torque (Nm)	Actuator Volume (cm ³)	Weight Outer (kg)	Weight Inner (kg)	WR2 Outer (kgm ³)	WR2 Inner (kgm ³)	Maximum RPM
HC-8-6	6200	4400	72	3	27	0.023	0.160	2600
HC-8-8	8000	5600	72	3	30	0.030	0.170	2600
HC-8-10	9500	6800	72	4	32	0.038	0.181	2600
HC-10-6	8500	6000	120	4	38	0.043	0.316	2200
HC-10-8	11000	8000	120	5	41	0.058	0.340	2200
HC-10-10	14000	10000	120	6	44	0.072	0.362	2200
HC-13-6	22500	16000	229	7	89	0.181	1.513	1700
HC-13-8	31000	22000	229	10	96	0.224	1.618	1700
HC-13-10	40000	28000	229	12	103	0.304	1.719	1700
HC-15-6	36000	26000	311	15	132	0.464	2.823	1450
HC-15-8	48000	34000	311	20	143	0.632	3.034	1450
HC-15-10	60000	42000	311	26	155	0.801	3.245	1450
HC-16-6	50000	36000	393	18	162	0.674	4.340	1300
HC-16-8	67500	48000	393	24	176	0.927	4.635	1300
HC-16-10	85000	60000	393	30	189	1.138	4.973	1300
HC-18-6	65000	46000	508	29	224	1.264	6.911	1200
HC-18-8	80000	56000	508	38	247	1.686	7.543	1200
HC-18-10	105000	76000	508	48	269	2.107	8.175	1200
HC-20-6	85000	62000	836	43	304	2.444	11.757	1100
HC-20-8	115000	82000	836	58	331	3.287	12.642	1100
HC-20-10	144000	10300	836	72	357	4.088	13.527	1100

NOTES
 1) operating pressure 24 BAR
 2) Torque capacities can be modified. Consult Engineering.
 3) Consult factory for service factors required per application
 4) Consult factory for oil flow requirements per application and shaft oil hole diameters

HC (Dry) Clutches

Model HC (Dry)

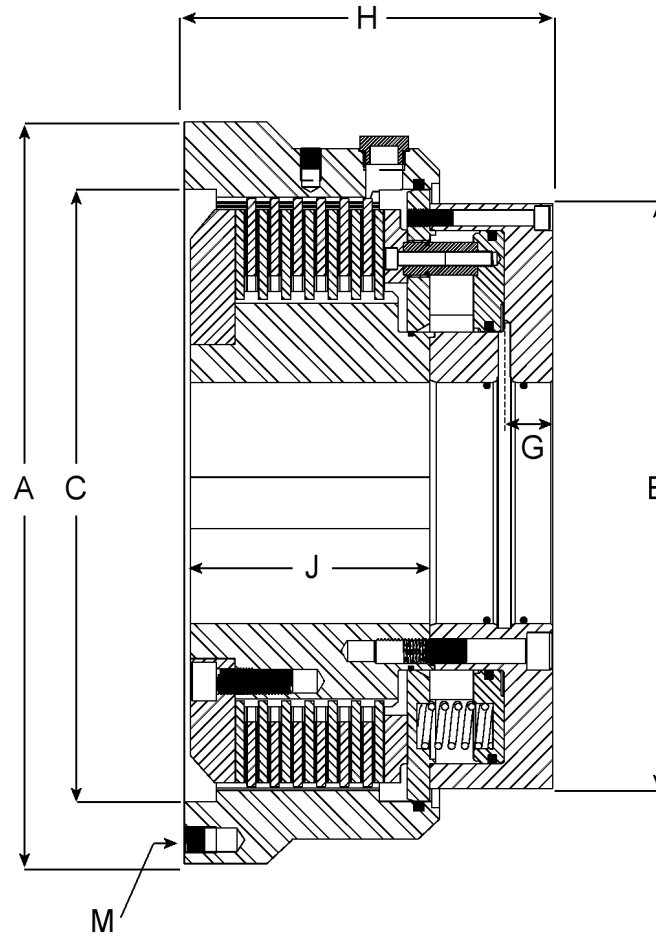

Dimensions (mm):

Clutch Model	A	B	C	D	E	F	G	H	I	J	K	L	M
HC-8-6	257	-	222	-	211	-	13	150	-	108	-	-	12 x M10
HC-10-6	298	-	264	-	249	-	14.2	166	-	117	-	-	12 x M10
HC-13-6	430	-	365	-	351	-	18.3	213	-	129	-	-	24 x M20
HC-15-6	400	-	416	-	400	-	19.8	234	-	154	-	-	30 x M20
HC-18-6	600	-	495	-	473	-	38	290	-	188	-	-	36 x M20
HC-20-6	660	-	546	-	524	-	44.4	312	-	201	-	-	36 x M24

Model HC (Dry)

The Model HC (Dry Lining) clutches are designed to be used in either an end of shaft or through shaft mounting configuration. The use of 24 bar hydraulic actuation and multiple dry organic lined friction plates provides a clutch range with very high torque capability relative to overall diameter. The end result is a clutch that is compact dimensionally, whilst providing high torque solutions in the smallest envelope space.



The Model HC(D) clutches are provided with an internally splined outer drive ring for bolting to the users driving or driven member. The clutch can also be supplied without an external drive ring to allow for customers to incorporate the external drive spline within a component of their own manufacture. This possibility enables designs where minimal axial space is desirable, by allowing the clutch to fit within the customers driving or driven component.

Actuation pressure may come from either a pneumatic or hydraulic source. This pressure may be introduced through an axial hole provided at the shaft centreline, or, in the case of end shaft mounts, it may be introduced through a separate manifold.

All torque transmitting members are designed to provide for continuous heavy duty industrial service. Hubs and drive rings are fully hardened and manufactured from high quality alloy steel forgings. Disc pack cores are designed using extra-heavy plate thicknesses to maximise torque and heat capacity.

Friction materials designed to provide for high thermal load acceptance and smooth engagement performance.

The clutch range is designed for use in harsh external environments benefitting from a completely enclosed design and incorporating a dust / water ingress seal between the rotating components this makes it ideal for applications open to the elements. Optional 2 pack epoxy paint finishes provide additional protection and can be specified if required.

Winch connect / disconnect drives, conveyor or mill drives and multi-speed transmissions are but a few of the applications for the model HC/HCD dry lined clutch range.

Operational Data:

Clutch Model	Static Torque (Nm)	Dynamic Torque (Nm)	Actuator Volume (cm ³)	Weight Outer (kg)	Weight Inner (kg)	MR2 Outer (kgm ³)	MR2 Inner (kgm ³)	Maximum RPM
HC-8-6	15525	18628	71.6	2.63	27.48	0.079	0.159	2600
HC-10-6	20550	24468	119.6	3.53	37.9	0.043	0.316	2200
HC-13-6	56110	66045	229.41	7.39	88.7	0.168	1.512	1700
HC-15-6	90205	106126	311.35	15.42	131.99	0.463	2.823	1450
HC-18-6	155802	178945	507.99	28.57	224.07	1.264	6.911	1200
HC-20-6	278410	320626	835.74	35.83	298.46	1.938	11.378	1100

CSM/KK Clutches and Brakes

CSM Brakes

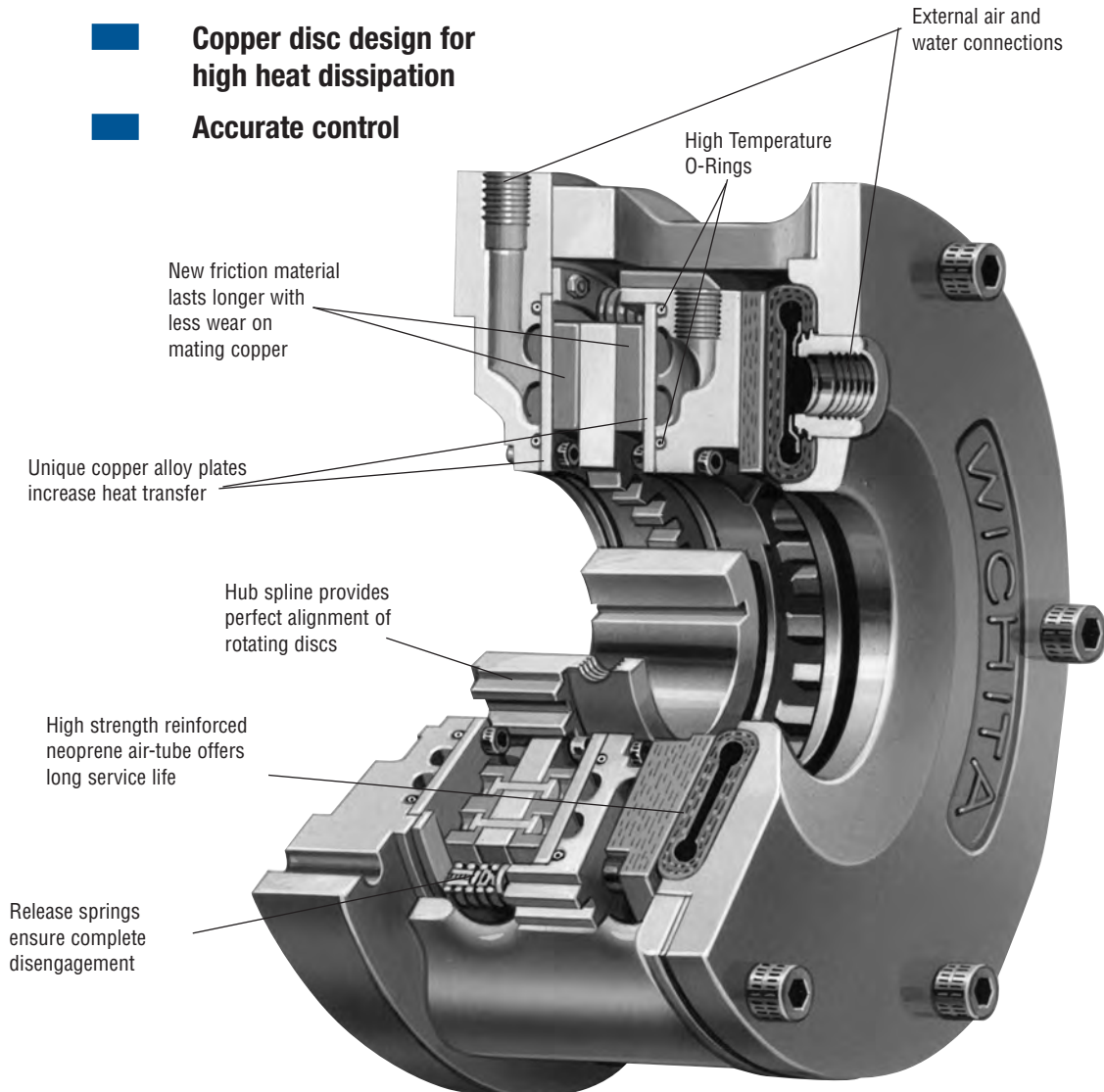

The Wichita CSM (or Kopper Kool) airtube disc Clutches and Brakes are liquid cooled and consist of a series of alternating discs connecting an inner drive member to an outer drive member.

Engagement is achieved by pneumatic expansion of the airtube. This air-operated clutch contains copper discs for excellent heat dissipation and provides an accurately controlled continuous slip action for constant web tensioning. Tension levels are in direct proportion to air pressure applied.

Design Features

- New friction material lasts longer with less wear on mating copper.
- Copper alloy wear plates increase heat transfer.
- Hub spline provides perfect alignment of rotating discs.
- External air & water connections.
- Release springs ensure complete disengagement.
- High strength reinforced neoprene air-tube offers long service life.
- High thermal capacity.

For additional torque and heat capacity, see the Wichita AquaMaKKs on page 82.

Water Cooled/High Heat Capacity

CSM Brakes

Component Parts

- | | |
|------------------------------------|-----------------------------------|
| 1. Socket Head Capscrews | 8. Ring (Airtube End) |
| 2. Backplate Water Jacket Assembly | 9. Floating Water Jacket Assembly |
| 3. Release Springs | 10. Pressure Plate |
| 4. Ring (Backplate End) | 11. Airtube |
| 5. Hub | 12. Segmented Shims |
| 6. Drive Plate Assembly | 13. Airtube Holding Plate |
| 7. Center Water Jacket Assembly | 14. Socket Head Capscrews |

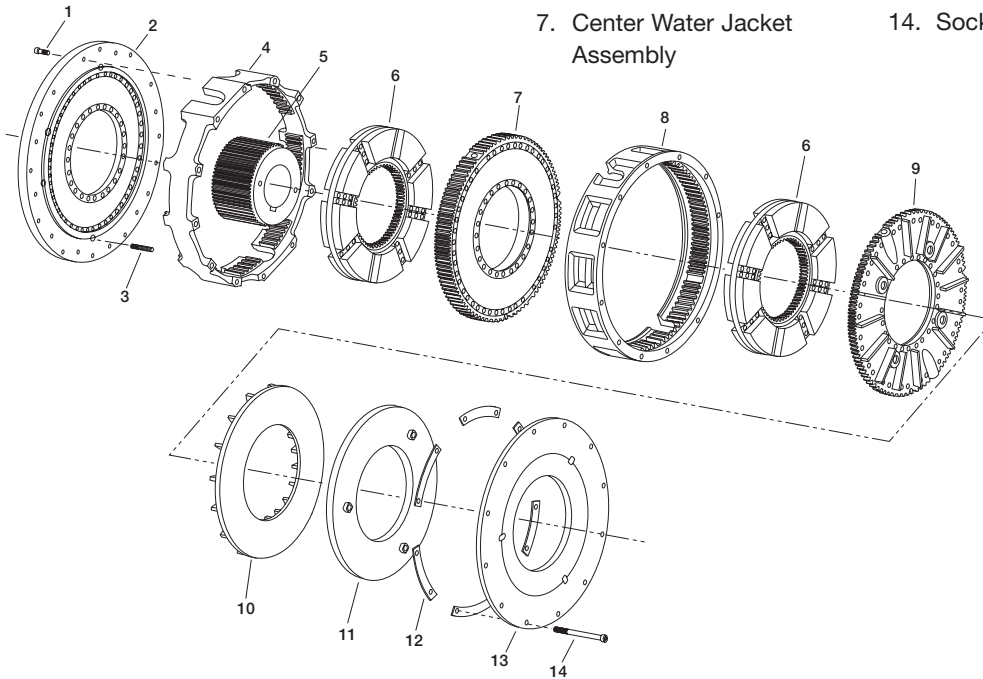

Principle of Operation

Closed Cooling System

As shown here in the closed loop system, flexible water lines should be brought into each jacket at the 6 o'clock position. When the CSM Unit is used as a clutch, air vent tubes must be installed internally at the factory to insure proper filling of the water jackets. The CSM Clutches also require 0.35 BAR back pressure on the outlet side of the triple passage roto-coupling to insure complete evacuation of air from these jackets during rotation.

Referring to the closed loop cooling system, the equipment should be protected with low water pressure and high temperature warning devices. For availability information, contact factory.

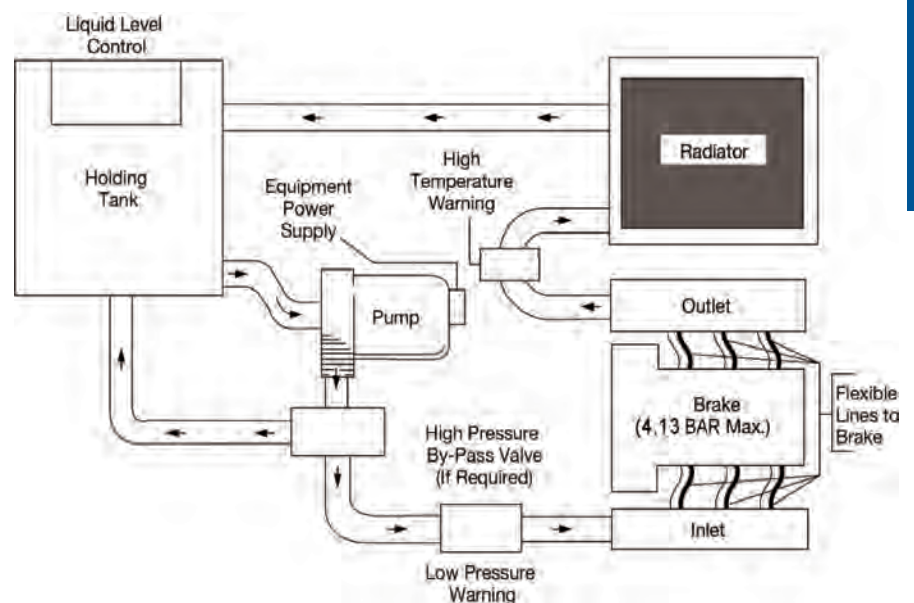

F

CSM/KK Clutches and Brakes

Design advantages

- New friction material is longer lasting with less wear on mating copper. Consistent torque response results directly with air pressure applied. Mechanically retained friction pads can be changed in field.
- Copper has a greater heat transfer capacity than most other metals.
- All factors affecting torque are fully controlled. Patented water flows through tangential cooling grooves to ensure effective mixing of cooling water for best heat conductivity. Water volume of the jackets insures high water velocity, which reduces sedimentation and chemical formation. Maximum inlet pressure is 4.13BAR/60 PSI.
- Close grain alloy iron jackets for coolant assure high resistance to corrosion.
- Releasing springs insure complete disengagement.
- By using a triple roto-coupling, the brake can be used as a constant slipping clutch.
- Composite pressure plate assures even distribution of pressure from actuator to braking surfaces, providing maximum contact area on friction surfaces.
- All coolant and air connections are external and easily accessible. Double outlets in center water jackets for multiple plate units 24" and larger.
- Air passages through brake greatly assist in keeping brake cool.
- Actuating member is a reinforced neoprene airtube which has low resistance to movement, resulting in immediate reaction with small pressure changes. Non-corrosion neoprene is unaffected by actuating medium.

Typical Applications

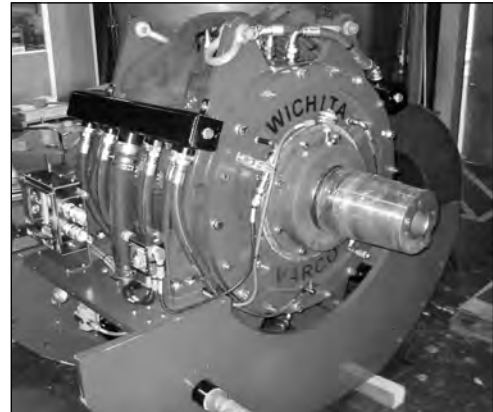

Wichita CSM Brakes provide precise weight on bit control on drawworks for drilling rigs.

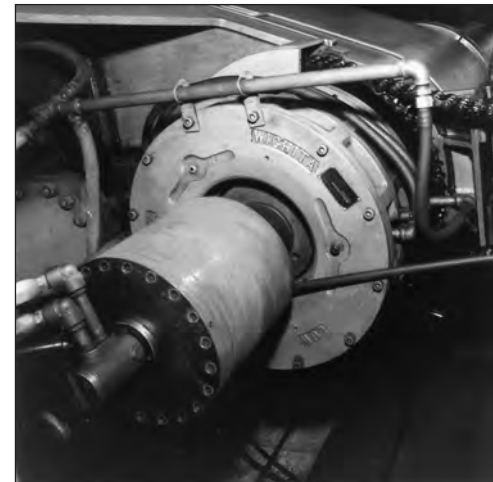

CSM Brakes dissipate high heat loads in steel uncoiler applications.

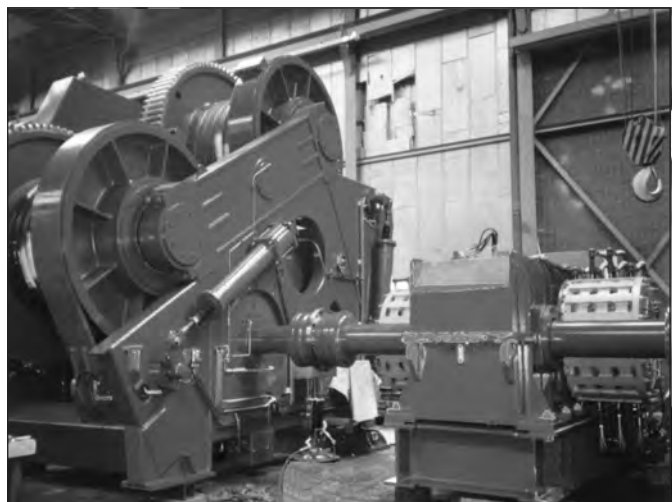

CSM brakes increase control on marine winches.



Selecting a CSM Brake for an unwind application

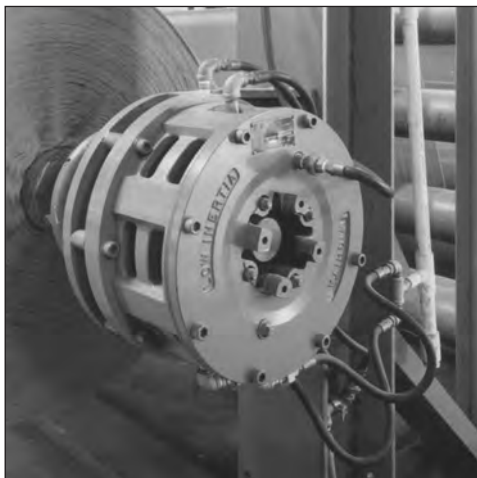

To properly select a tension brake for an unwind application the following information is needed:

Max. Roll Diameter	2135 mm.
Max. Web Width	3050 mm.
Max. Web Speed	450 M/min.
Max. Tension	2.63 N/mm.
Air Pressure Available	7 BAR.
Min. Roll Diameter	305 mm.
Min. Web Width	2135 mm.
Min. Web Speed	225 mm/min
Min. Tension	10 PLI

Calculations

For the calculations below, consult CSM Brake Specifications Chart on the next two pages.

The brake selected for this application is a CSM 218, with 5.5 inch bore.

$$\begin{aligned} \text{Max. Tension} &= \text{Max. N/mm} \times \text{Max. Web Width} \\ &= 2.63 \times 3050 = 8022 \text{ N.} \\ \text{Max. Torque} &= \frac{\text{Max. Tension} \times \text{Max. Roll Dia (M)}}{2} \\ &= 8022 \times 2.135/2 = 8563 \text{ Nm} \\ \text{Max. RPM} &= \frac{\text{Max. Web Speed}}{\text{Min. Roll Dia.} \times \pi} \\ &= 450 / (3.142 \times .305) = 470 \text{ RPM} \\ \text{Heat HP} &= \text{Max. Tension} \times \text{Max. Web Speed}/60,000 \\ &= \frac{8022 \times 450}{60,000} = 60.2 \text{ kW} \\ \text{Min. Tension} &= \text{Min. tension} \times \text{Min. Web Width (mm)} \\ &= 1.75 \times 2135 = 3736 \text{ N.} \\ \text{Min. Torque} &= \frac{\text{Min. Tension} \times \text{Min. Roll Dia.}}{2} \\ &= 3736 \times .305 = 570 \text{ Nm.} \\ \text{Min. RPM} &= \frac{\text{Min. Web Speed}}{\text{Max. Roll Dia.} \times \pi} \\ &= 225 / (3.142 \times 2.135) = 34 \text{ RPM} \end{aligned}$$

How to select

1. Select a brake with equal to or greater thermal capacity. The CSM214 has 115 kW x 0.7 = 78.4 kW. The requirement is 60.2 kW.
2. Check torque capacity vs. required. The CSM214 has 4745 Nm @ 5.5 bar. The requirement is 8563 Nm. Therefore, a CSM214 Brake will not produce enough torque for this application. A CSM218 Brake would be the best choice.
3. Check maximum bore. The requirement is 5.00 inches. The CSM218 maximum bore is 5.5 inches
4. Check maximum RPM. The requirement is 470 RPM. The maximum RPM for the CSM218 is 1300 RPM.

$$\begin{aligned} \text{Max. Air Pressure Required} &= \frac{\text{Max. Torque} \times 7 \text{ BAR}}{\text{Catalog Torque Rating}} \\ &= \frac{8563 \times 7}{10620} = 5.64 \text{ BAR} \end{aligned}$$

$$\begin{aligned} \text{Min. Air Pressure Required} &= \frac{\text{Min. Torque} \times 7 \text{ BAR}}{\text{Catalog Torque Rating}} \\ &= \frac{570 \times 7}{10620} = 0.38 \text{ BAR} \end{aligned}$$



CSM/KK Clutches and Brakes

CSM Brakes

Specifications

Model Size ATD-	Dynamic Torque Capacity*		Heat Capacity		Max Bore
			Series	Parallel	
	5.5 BAR	7 BAR	Water Hosing HP/kW	Water Hosing HP/kW	Rect. Key mm
CSM 106	151	192	10 / 7.5	15 / 11	44
CSM 206	302	384	20 / 15	30 / 22	
CSM 108	479	610	21 / 16	32 / 24	
CSM 208	959	1220	42 / 31	64 / 48	57
CSM 308	1438	1830	63 / 47	96 / 72	
CSM 111	1065	1356	35 / 26	53 / 40	
CSM 211	2131	2712	70 / 52	105 / 78	76
CSM 311	3196	4067	105 / 78	158 / 118	
CSM 114	1864	2373	50 / 37	75 / 56	
CSM 214	3728	4745	100 / 75	150 / 112	111
CSM 314	5593	7118	150 / 112	225 / 168	
CSM 116	2841	3615	65 / 48	98 / 73	121
CSM 216	5681	7231	130 / 97	195 / 145	
CSM 118	4172	5310	80 / 60	120 / 89	
CSM 218	8344	10620	160 / 119	240 / 179	140
CSM 318	12517	15930	240 / 179	360 / 268	
CSM 121	5504	7005	100 / 75	150 / 112	
CSM 221	11008	14010	200 / 149	300 / 224	165
CSM 321	16511	21015	300 / 224	450 / 336	
CSM 124H	11185	14236	190 / 142	285 / 213	
CSM 224H	22370	28471	380 / 283	570 / 425	194
CSM 324H	33556	42707	570 / 425	855 / 638	
CSM 127	13316	16947	175 / 130	263 / 196	203
CSM 227	26631	33894	350 / 261	233 / 174	
CSM 130	17754	22596	230 / 172	345 / 257	
CSM 230	35508	45193	460 / 343	690 / 515	229
CSM 330	53263	67789	690 / 515	1035 / 772	
CSM 136H	36154	45193	500 / 373	750 / 559	
CSM 236H	72308	90385	1000 / 746	1500 / 1119	229
CSM 336H	108462	135578	1500 / 1119	2250 / 1678	
CSM 436H ²	141227	180771	2000 / 1491	3000 / 2237	
CSM 346 ³	233468	297142	2200 / 1641	3300 / 2461	317

* Static torque will vary with temperature. Maximum air pressure is 100 PSI / 7 BAR. Minimum recommended air pressure is 3 PSI / 0.2 BAR.

Note: Maximum water jacket inlet pressure is 60 PSI / 4.13 BAR.

Brakes with as great as 50% higher torque capacity is available upon request.

¹ Current design is with enhanced linings. A unit with regular linings is available upon request.

² Current design is with the Marine Corrosion package. A Non-Marine unit is available upon request.

³ Current design is for intermittent duty applications. Such as, anchor, mooring, take-up and traction type winch applications.

Water Cooled/High Heat Capacity

Model Size ATD-	Max. Speed RPM	Parallel Water Flow % Ethylene Glycol			Total Brake Wt. kg	Hub & Drive Plate	
		LPM				Wt. kg	J=mr ² kgm ²
		0%	30%	50%			
CSM 106	3,800	6	7.4	8.5	20.4	2.5	0.01
CSM 206		11	14.8	17	32.2	5.3	0.01
CSM 108		12	1.6	19	30.8	5.0	0.03
CSM 208	2,860	24	32	38	52.6	11.1	0.05
CSM 308		36	48	57	74.4	17.2	0.08
CSM 111		20	26	30	66.2	10.9	0.08
CSM 211	2,100	40	52	60	104.3	24.5	0.17
CSM 311		60	78	78	142.4	38.1	0.25
CSM 114		28	37	45	100.2	18	0.21
CSM 214	1,600	57	74	90	156.5	36	0.44
CSM 314		84	111	135	213.2	54	0.67
CSM 116		37	48	56	135	34	0.51
CSM 216	1,400	74	96	111	295	65	1.07
CSM 118		45	60	72	188	39.9	0.76
CSM 218		90	120	144	256	79.8	1.52
CSM 318	135	180	216	324	119.7	2.28	
CSM 121	1,100	57	74	90	272	63	1.43
CSM 221		114	148	170	395	103	2.70
CSM 321		170	221	255	488	137	4.09
CSM 124H	960	106	144	170	424	109	4.64
CSM 224H		212	288	340	680	186	8.85
CSM 324H		318	432	510	937	263	13.07
CSM 127	850	102	133	153	445	103	3.87
CSM 227		204	266	307	599	193	7.55
CSM 130		132	170	204	514	119	5.86
CSM 230	760	264	340	408	839	240	11.59
CSM 330		396	510	612	1163	361	17.28
CSM 136H		284	369	454	1157	243	17.28
CSM 236H	640	568	738	908	1865	420	33.31
CSM 336H		852	1107	1362	2538	764	68.3
CSM 436H		1136	1476	1703	3072	997	87.6
CSM 346	480	1249	1624	1874	4899	1379	210

CSM Brakes

Specifications (Continued)

Model Size ATD-	Pressure Drop Parallel Flow w/ % Ethylene Glycol PSI / BAR			Pressure Drop Series Flow w/ % Ethylene Glycol PSI / BAR			Maximum Lining Wear		Water Volume dm ³
	0%	30%	50%	0%	30%	50%	cm	dm ³	
CSM 108				4 / 0.14	9 / 0.62	9 / 0.62			0.13
CSM 208	0.9 / 0.06	1.6 / 0.11	2.3 / 0.16	11 / 0.76	25 / 1.72	32 / 2.21	1.0	0.2	0.26
CSM 308				15 / 1.03	34 / 2.34	41 / 2.83			0.4
CSM 114				4 / 0.14	8 / 0.55	12 / 0.83			0.33
CSM 214	1.2 / 0.08	1.6 / 0.11	1.8 / 0.12	24 / 1.66	40 / 2.76	52 / 3.59	1.3	1.0	0.65
CSM 314				28 / 1.93	48 / 3.31	—			1
CSM 118				7 / 0.48	13 / 0.9	20 / 1.38			0.8
CSM 218	1.7 / 0.12	2.4 / 0.17	2.8 / 0.19	52 / 3.59	—	—	1.5	1.2	1.5
CSM 318				—	—	—			2.35
CSM 124H				7 / 0.48	11 / 0.76	14 / 0.97			1.8
CSM 224H	1.9 / 0.13	2.4 / 0.17	3.1 / 0.21	23 / 1.59	35 / 2.41	48 / 3.31	2.0	3.3	3.6
CSM 324H				30 / 2.07	46 / 3.17	—			1.8
CSM 130				9 / 0.62	14 / 0.97	21 / 1.45			3.1
CSM 230	2.1 / 0.14	2.4 / 0.17	3.1 / 0.21	31 / 2.14	48 / 3.31	—	2.0	3.9	6.2
CSM 330				40 / 2.76	—	—			9.3
CSM 136H				14 / 0.97	24 / 1.66	—			4.7
CSM 236H	4.0 / 0.28	5.3 / 0.37	7.2 / 0.50	60 / 4.14	—	—	2.0	8.2	9.3
CSM 336H				—	—	—			14

CSM/KK Clutches and Brakes

CSM Brake

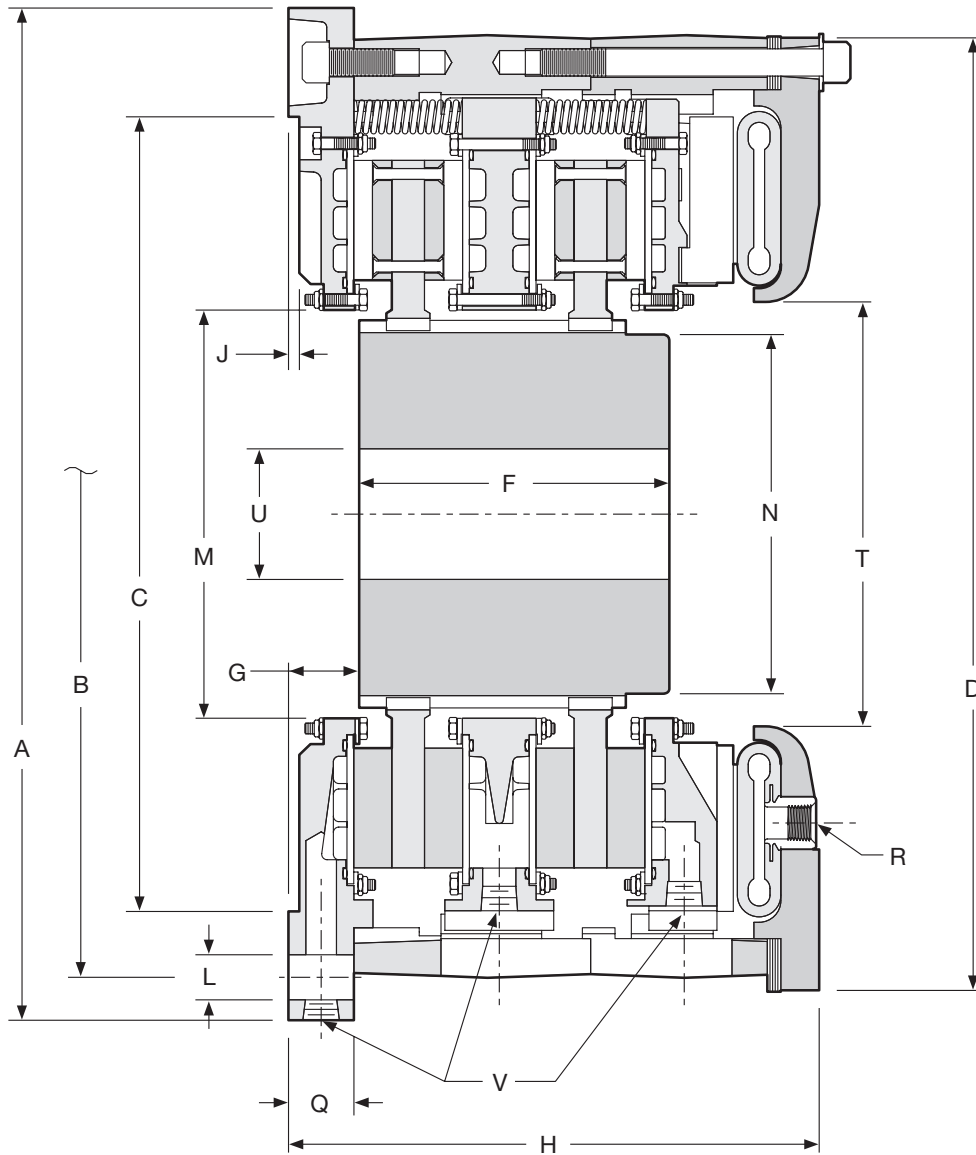

For mounting hole pattern, see following pages.

Water Cooled/High Heat Capacity

Dimensions: mm

Model Size ATD-	A Pilot	B Hole Circle	C ⁽¹⁾ Pilot	D	F	G	H	J
CSM 106					50.8		133.4	3.3
CSM 206	220	203.2	190	223.8	117.6	19.1	193.8	
CSM 108					50.8		144.3	
CSM 208	310	282.58	220	288.5	108	28.7	214.1	6.4
CSM 308					177.8		282.4	
CSM 111					73.2		160.5	
CSM 211	400	374.65	295	374.7	155.7	19.1	242.8	6.4
CSM 311					231.6		325.4	
CSM 114					82.6	26.9	177.8	
CSM 214	470	444.5	370	444.5	149.4	42.9	268.5	6.4
CSM 314					231.9	42.9	358.9	
CSM 116					101.6	31.8	192.0	6.4
CSM 216	540	508	410	508	177.8		292.1	
CSM 118					921.2	26.9	203.2	
CSM 218	590	558.8	470	555.8	181.1	41.4	309.6	6.4
CSM 318					273.1	41.4	416.1	
CSM 121					139.7	31.8	212.9	
CSM 221	685	647.7	540	632	201.7	38.1	401.6	6.4
CSM 321					316	31.8	436.6	
CSM 124H					127		248.7	
CSM 224H	760	730.25	620	787.4	219.2	35.1	372.9	6.4
CSM 324H					346.2		496.8	

⁽¹⁾ Dimension "C" is given as a nominal figure. The applicable tolerance is ISO H7. (Consult factory for drawing before final layout.)

Dimensions: mm

Model Size ATD-	L		M	N	Q	R		T	U		V ⁽²⁾ - Inlets	
	No.	Size				No.	Size		Min.	Max.	No.	Size
CSM 106												2 - 1/4 NPT
CSM 206	4 x	Ø9	74.7	61.7	9.7	2 -	1/2 NPT	50.8	15.2	44.5		3 - 1/4 NPT
CSM 108												2 - 3/8 NPT
CSM 208	4 x	Ø14	111.3	88.9	35.1	2 -	1/2 NPT	95.3	25.4	57.2		3 - 3/8 NPT
CSM 308												4 - 3/8 NPT
CSM 111												2 - 1/2 NPT
CSM 211	4 x	Ø18	136.7	117.6	28.7	2 -	1/2 NPT	133.4	25.4	76.2		3 - 1/2 NPT
CSM 311												4 - 1/2 NPT
CSM 114												2 - 1/2 NPT
CSM 214	6 x	Ø18	187.5	165.1	38.1	2 -	1/2 NPT	177.8	35.1	111.3		3 - 1/2 NPT
CSM 314												4 - 1/2 NPT
CSM 116	10 x	Ø18				2 -	1/2 NPT					2 - 1/2 NPT
CSM 216			218.9	190.5	38.1			212.9	35.1	120.7		3 - 1/2 NPT
CSM 118												2 - 1/2 NPT
CSM 218	10 x	Ø18	238.3	209.6	38.1	3 -	1/2 NPT	247.7	50.8	139.7		3 - 1/2 NPT
CSM 318												4 - 1/2 NPT
CSM 121												2 - 3/4 NPT
CSM 221	10 x	Ø18	289.1	266.7	44.5	3 -	1/2 NPT	289.1	50.8	165.1		3 - 3/4 NPT
CSM 321												4 - 3/4 NPT
CSM 124H												2 - 1 NPT
CSM 224H	10 x	Ø18	322.3	292.1	23.9	3 -	1/2 NPT	384.0	50.8	193.8		4 - 1 NPT
CSM 324H												6 - 1 NPT

⁽²⁾ Number of inlets and outlets are equivalent.

(Consult factory for drawing before final layout.)

F

CSM/KK Clutches and Brakes

CSM Brake

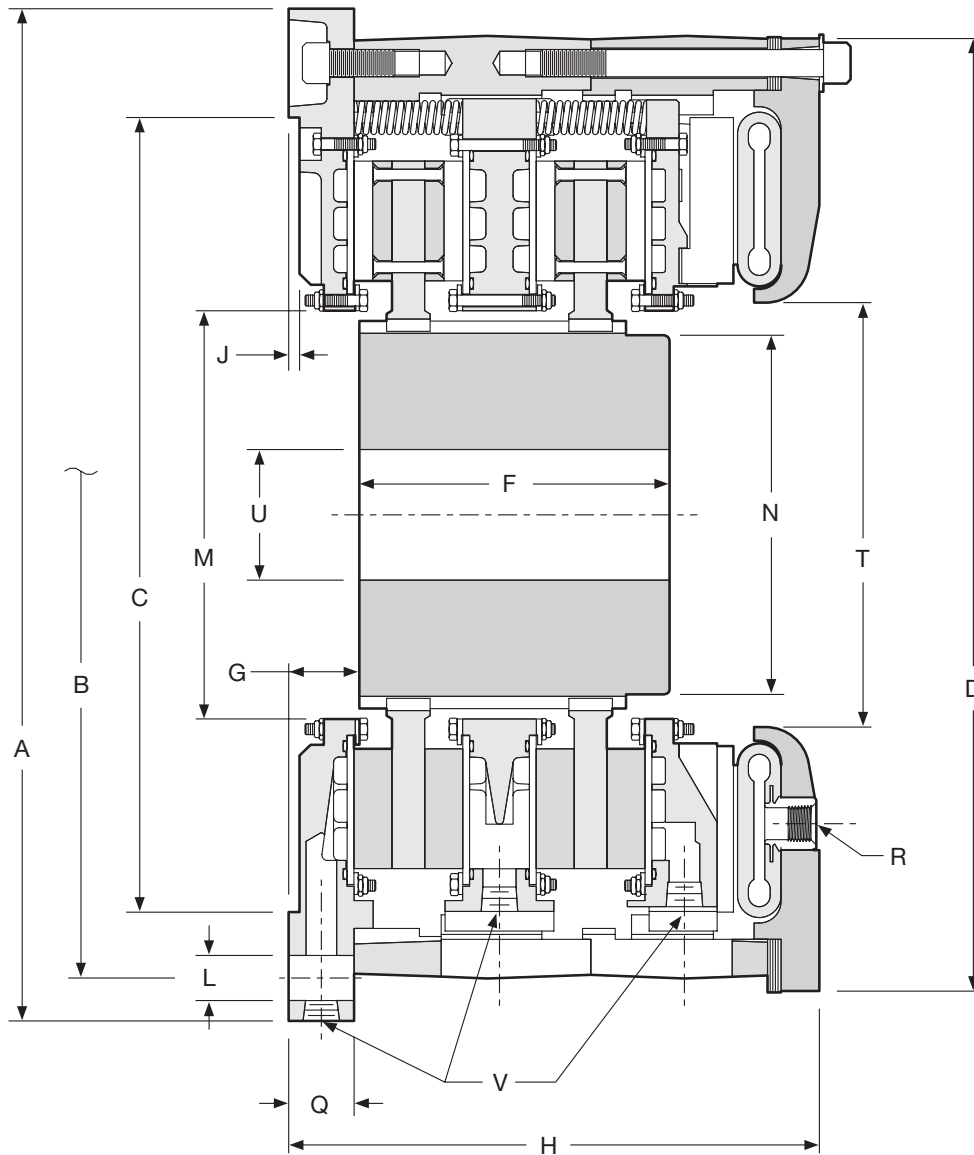

For mounting hole pattern, see following pages.

Water Cooled/High Heat Capacity

Dimensions: mm

Model Size ATD-	A Pilot	B Hole Circle	C ⁽¹⁾ Pilot	D	F	G	H	J
CSM 127					127		228.6	
CSM 227	832	800.10	700	384.3	219.2	35.1	349.3	6.4
CSM 130					117.6		239.8	
CSM 230	940	901.7	775	882.7	235	35.1	362	6.4
CSM 330					352.6		482.6	
CSM 136H					143	28.7	320.8	
CSM 236H	1105	1066.8	925	1130.3	279.4	36.3	89.2	6.4
CSM 336H ⁽²⁾					422.4	36.3	654.3	
CSM 436H ⁽²⁾	1130	1079.5	925	1130.3	628.7	36.3	819.4	6.4
CSM 346 ⁽²⁾	1492	1441.45	1220	1441.45	527.1	69.9	739.9	6.4

⁽¹⁾ Dimension "C" is given as a nominal figure. The applicable tolerance is ISO H7. (Consult factory for drawing before final layout.)

⁽²⁾ For dimensions of the 36H, 46, and 48 models please consult factory for drawing before final layout.

Dimensions: mm

Model Size ATD-	L		M	N	Q	R	T	U		V ⁽³⁾ - Inlets	
	No. -	Size				No. -		Size	Min.	Max.	No. -
CSM 127	14 x	Ø18				3 -	1/2 NPT			2 -	3/4 NPT
CSM 227			358.9	317.5	44.5			63.5	203.2	3 -	3/4 NPT
CSM 130						4 -	1/2 NPT			2 -	1 NPT
CSM 230	16 x	Ø22	400.1	362	50.8			63.5	228.6	4 -	1 NPT
CSM 330										6 -	1 NPT
CSM 136H ⁽²⁾										2 -	1.25 NPT
CSM 236H ⁽²⁾	16 x	Ø22	419.1	355.6	30.2	4 -	1/2 NPT			4 -	1.25 NPT
CSM 336H ⁽²⁾								152.4	228.6	6 -	1.25 NPT
CSM 436H ⁽²⁾	16 x	Ø22	419.1	355.6	31.8	4 -	1/2 NPT			8 -	1.25 NPT
CSM 346 ⁽²⁾	22 x	Ø22	736.6	609.6	79.5	4 -	1/2 NPT			6 -	1.25 NPT
								203.2	406.4		

⁽³⁾ Number of inlets and outlets are equivalent.

(Consult factory for drawing before final layout.)

F

CSM/KK Clutches and Brakes

CSM Brakes - Mounting Hole Pattern

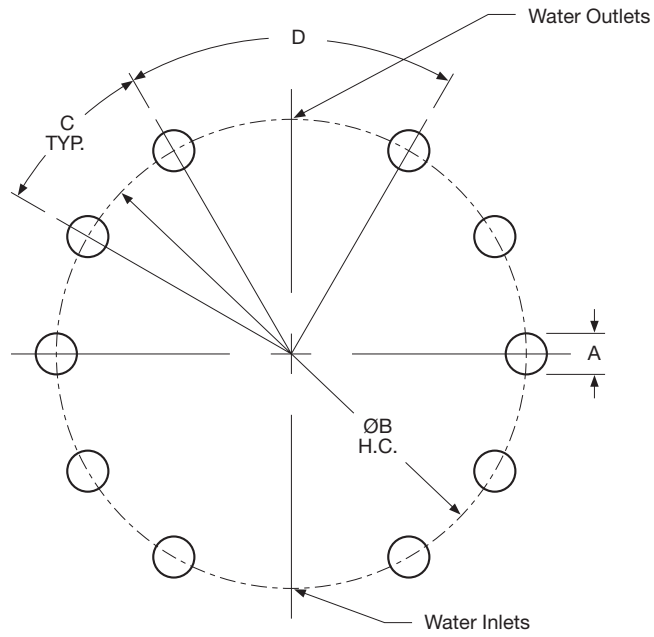

CSM Brakes

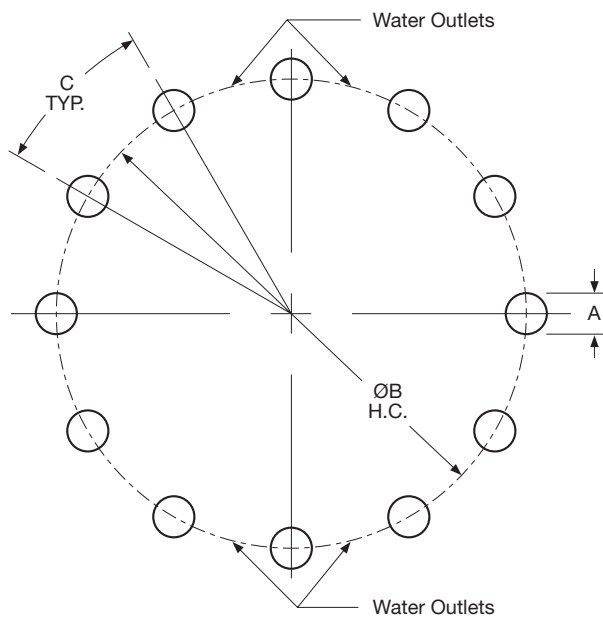

Sizes 19 & 25

Water Cooled/High Heat Capacity

Dimensions: mm

Model CSM	No. of Mounting Holes	A Size	B Hole Circle	No. of Holes, Hole Pattern is Based	C	D
6	4	8.6	203.20	4	45°	90°
8	4	13.5	282.58	6	60°	120°
11	4	16.7	374.65	6	60°	120°
14	6	16.7	444.50	8	45°	90°
16	10	16.7	508.00	12	30°	60°
18	10	16.7	558.80	12	30°	60°
19	12	17.5	558.80	12	30°	—
21	10	16.7	647.70	12	30°	60°
24H	10	16.7	730.25	12	30°	60°
25	12	16.7	730.25	12	30°	—
27	14	16.7	800.10	16	22.5°	45°
30	16	19.8	901.70	18	20°	40°
36H	16	20.6	1066.80	18	20°	40°
436H	16	26.9	1079.50	18	20°	40°
46	22	26.2	1441.45	24	15°	30°

CSM/KK Clutches and Brakes

CSM Brakes - Spring-Set Brakes

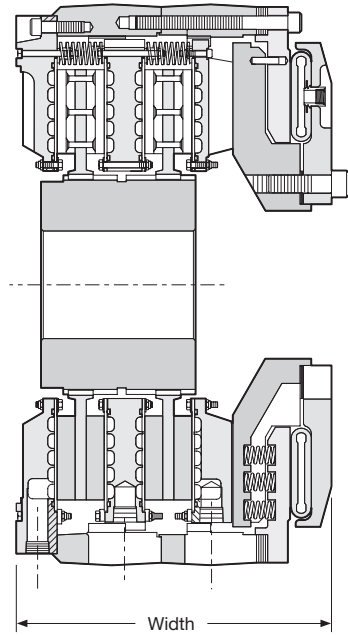

CSM SS Brake

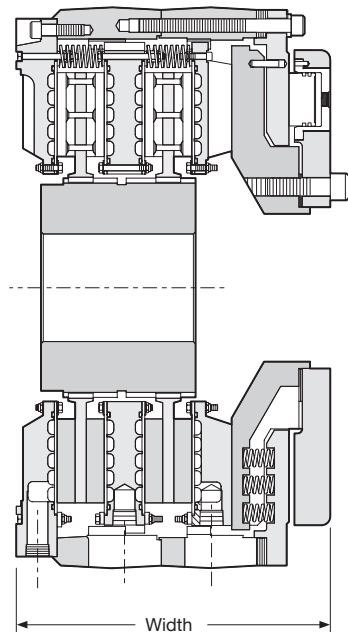

CSM SS-HYD Brake

See previous pages for dimensional information.

Water Cooled/High Heat Capacity

Dimensions: mm

Model Size ATD-	Dynamic Torque Capacity*		Width mm
	Nm	Release Pressure BAR	
CSM SSB 218	5434	6.2	381
CSM SSB 224H ⁽³⁾	11840	5.2	446.8
CSM SSB-HYD 124H	9942	88.3	320.8
CSM SSB-HYD 224H	18077	88.3	445
CSM SSB 330H ⁽¹⁾	84612	6.9	576.3
CSM SSB 236H ^(2,4)	73370	8.3	559.6
CSM SSB 336H ^(1,2,4)	133070	6.9	726.4
CSM SSB 336H ^(2,4)	106270	8.3	726.4

* Static torque will vary with temperature.

Note: Maximum water jacket inlet pressure is 4.13 BAR.

Brakes with as great as 50% higher torque capacity is available upon request.

⁽¹⁾ Current design is with enhanced linings. A unit with regular linings is available upon request.

⁽²⁾ Current design is with the Marine Corrosion package. A Non-Marine unit is available upon request.

⁽³⁾ Current design is without hub. A unit with hub is available upon request.

⁽⁴⁾ Mounting same as 436H CSM except with 1079.5 mm hole circle.

Feature Differences: The CSM SS brake uses air to release the brake, where as the CSM SS-HYD brake uses hydraulic pressure to release the brake.

CSM/KK Clutches and Brakes

CSM Custom Units - CSM SS Clutch

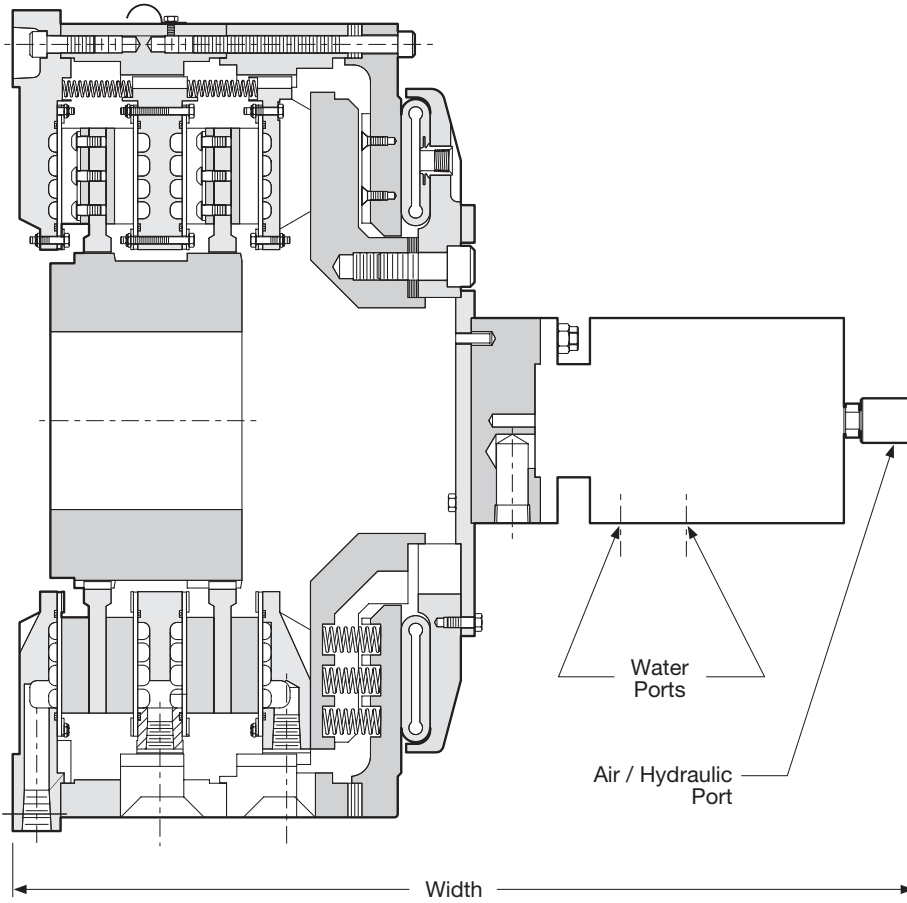

See previous pages for dimensional information.

Water Cooled/High Heat Capacity

Dimensions: mm

Model Size ATD-	Dynamic Torque Capacity* with Release Pressure		Heat Capacity HP (kW)	Roto - Coupling NPT	Max. Speed		Width mm
	Nm	BAR			R/C RPM	Unit RPM	
CSM SSC 224 ⁽²⁾	8389	5.2	260 ⁽⁴⁾	1-1/4"	40	475	838.2
CSM SSC 324 ⁽²⁾	12507	5.2	300 ⁽⁵⁾	1-1/4"	40	475	954.5
CSM SSC 224H ^(1,2)	17764	5.2	425 ⁽⁶⁾	1-1/2"	250	475	987.3
CSM SSC 324H ^(1,2)	31488	6.6	300 ⁽⁶⁾	1-1/4"	40	475	991.4
CSM SSC 236H ^(2,3)	61247	6.9	975 ⁽⁵⁾	2"	250	300	819.2
CSM SSC-HYD 236H ^(2,3)	61247	100.0	975 ⁽⁵⁾	2"	250	300	819.2

* Dynamic torque will vary with temperature.

Note: Maximum water jacket inlet pressure is 4.13 BAR.

Brakes with as great as 50% higher torque capacity is available upon request.

⁽¹⁾ Current design is with enhanced linings. A unit with regular linings is available upon request.

⁽²⁾ Current design is with the Marine Corrosion package. A Non-Marine unit is available upon request.

⁽³⁾ Mounting same as 436H CSM except with 1079.5 mm hole circle.

⁽⁴⁾ Series hosing

⁽⁵⁾ Parallel hosing

⁽⁶⁾ Partial-parallel hosing

Feature Differences: The CSM SS clutch uses air to release the clutch where as; the CSM SS-HYD clutch uses hydraulic pressure to release the clutch.

CSM/KK Clutches and Brakes

3-Way Roto-Coupling (for water-cooled Clutches)

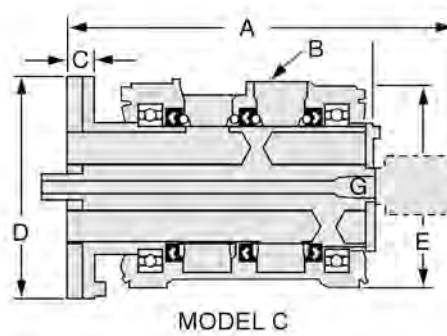
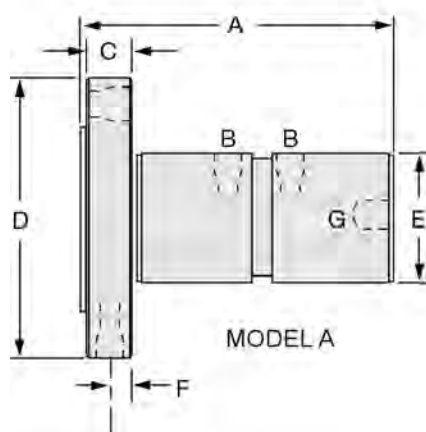
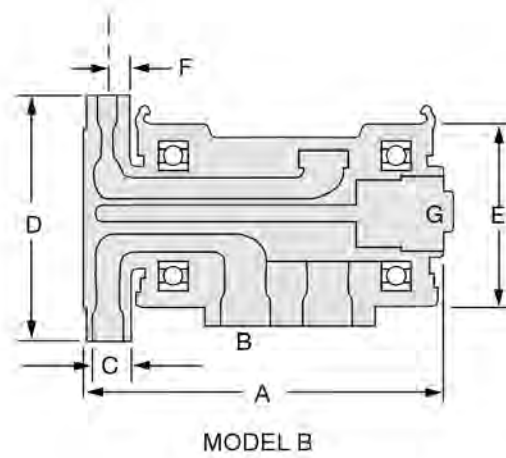
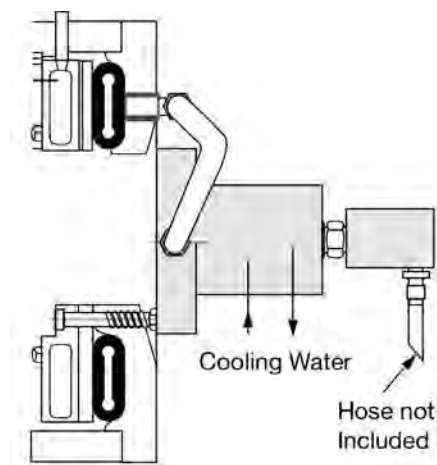

Dimensions: inches

	A	B	C	D	E	F	Thread Size G
MODEL A	7.250	3/8"-18 NPT	1.00	6.50	3.000	.50	5/8"-18
MODEL B	11.000	1-1/4"-11-1/2 NPT	1.375	7.25	5.375	.687	1/4" NPT
MODEL C	18.875	2"-11-1/2 NPT	1.250	10.00	9.000	—	1"-14



CSM Brake Air Hose Kits

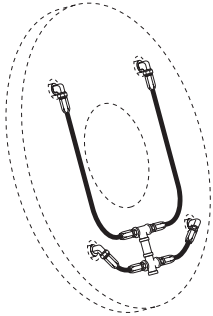
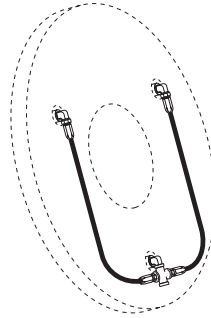
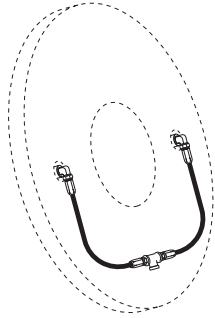
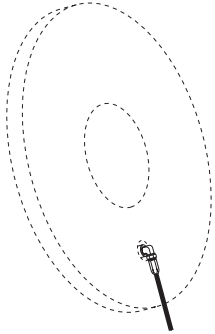

Air hose kits contain all necessary parts (fittings, hoses and extensions) to completely plumb the brake air system.

Optional Quick Release Valves can replace elbows on most units (see page 20 & 21).

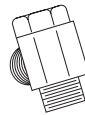



The newest addition to Wichita Clutch's family of water cooled airtube clutches and brakes

For increased torque and heat capacity, Wichita has introduced the AquaMaKKs™ range clutches and brakes, which are pneumatically or hydraulically controlled and water cooled. They consist of a series of alternating friction discs and water jackets. Torque is transmitted by applying axial force from the pneumatic, hydraulic, or spring set actuator. Copper wear plates are used for superior heat dissipation. AquaMaKKs provides accurate torque control for constant tensioning and are perfectly suited for applications in oil and gas, metal processing and forming, forestry, and marine deck machinery. See the following page for AquaMaKKs™ applications:

Design Benefits

- Simplicity of design with fewer parts simplifies installation and maintenance, saving both time and money.
- The standard AquaMaKKs design incorporates premium materials and finishes suitable for marine deck environments. No optional salt water corrosion protection is required.
- Shim design makes it easy to maintain and adjust for wear.
- Unique patent pending water jacket design ensures high heat absorption and torque stability, allowing for greater heat dissipation over similar sized competitive units.
- Unique mounting pattern enables direct replacement to Wichita or competitors' units, requiring no design changes for the customer.
- AquaMaKKs is a perfect solution for field retrofits, rebuilds or new OEM applications.

AquaMaKKs Clutches and Brakes

AquaMaKKs Water Cooled Clutches and Brakes

Air, hydraulic, or spring set actuated and water cooled design, featuring copper wear plates optimized for heavy-duty continuous slip tension applications



Oil and Gas

The AquaMaKKs family is ideally suited for superior water cooled tension control for drawworks applications.

It also can be the perfect solution for integration into electronic drilling systems as well as traditional style drawworks control systems.

Features that make AquaMaKKs ideal for oil and gas applications:

- Compatible with major electronic drilling systems
- Airtube design has less hysteresis than piston type actuators, making it ideal for automatic drilling systems
- Engineered packaged solutions including shafts, water kits, covers, and deck mounts
- The unit can be easily removed for service if required and/or quickly swapped out for maximum rig availability and rapid serviceability, reducing expensive downtime



Metal Processing & Metal Forming

AquaMaKKs clutches and brakes can be used to control tension on coilers in metal processing plants and to control tension in unwind stands and slitters in metal forming facilities.

Features that make AquaMaKKs ideal for metal processing and metal forming applications:

- Compatible with PLC control systems
- Higher thermal capacity than comparable models
- Easy to maintain minimizing downtime
- Open design concept for easy wear inspection
- Safety covers provided for increased operator and plant safety



Marine Deck Machinery

Positioning and Mooring Winches require high heat dissipation and accurate tension control. That's why AquaMaKKs is ideal for these applications.

Features that make AquaMaKKs ideal for marine deck applications:

- The standard AquaMaKKs design incorporates premium materials and finishes suitable for marine deck environments.
- Compatible with electronic and analog control systems for tension winches
- Long lasting friction material for improved wear life
- Optional designs available for suitability in low temperature environments
- Accessories and packaged engineered solutions available such as deck mounts, manifold kits, water connection kits, covers, and sensor mounting provisions

No optional salt water corrosion protection is required.



Forestry

AquaMaKKs water cooled brakes provide precise tension control on winch drives for mobile forestry equipment, such as yarders.

Features that make AquaMaKKs ideal for forestry applications:

- Compatible with tension control systems on yarders
- Open case design enables easy wear inspection and serviceability
- Higher thermal capacity than comparable models
- Lighter weight version available for mobile equipment

F

AquaMaKKs Clutches and Brakes

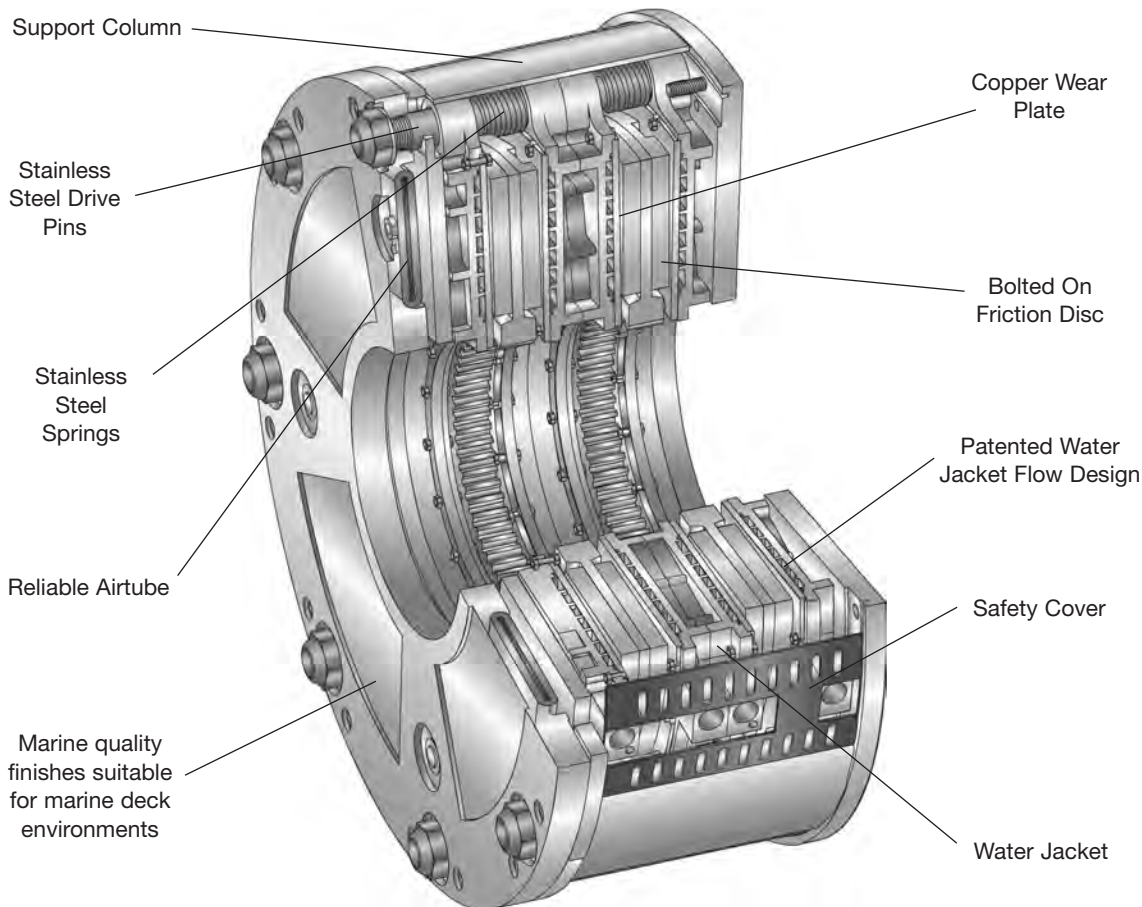

Features

- Durable air tube design with high strength reinforced neoprene air-tubes, offering longer service life.
- Water channels for balanced water flow for the highest thermal capacity.
- Long-lasting friction material with minimal wear on mating copper.
- Copper alloy wear plates enable higher heat transfer than any other metals.
- Hub spline provides perfect alignment of rotating discs.
- External air & water connections.
- Release springs ensure complete disengagement.
- Adjustment for wear is easily accomplished by removing shims without any unit disassembly.
- Unique torque pin column arrangement provides structural integrity of case.
- Open case design with covers for safe, simple, visual inspection and easy maintenance.
- The standard AquaMaKKs design incorporates premium materials and finishes suitable for marine deck environments. No optional salt water corrosion protection is required.

Options

- Standard and HICO friction materials available.
- Optional HICO friction material provides up to 50% higher torque.
- Provisions for electronic wear monitoring.
- Customer specific back-plate mounting configurations.
- Custom engineered solutions available for adding accessories such as deck mount assemblies, water kits, shaft assemblies, etc.
- Materials available for operation in low temperature environments.
- Hydraulic piston actuation available.
- Spring Set version with either air or hydraulic release available.

AquaMaKKs Clutches and Brakes

Order Numbering System

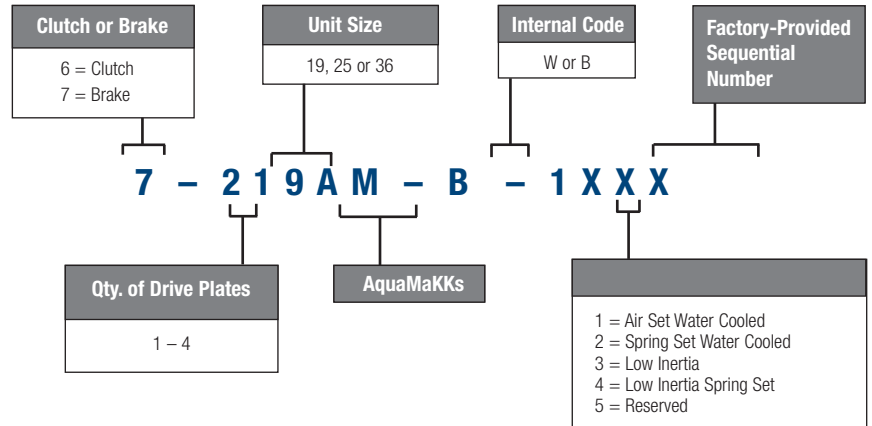

Dimensions and Specifications

Dimensions

inches mm

Model Size ATD-	Assembly Number	(A) Diameter		(B) Width	
		in.	mm	in.	mm
KKB119AM	7-119AM-B-1000	28.28	718	12.35	317
KKB219AM	7-219AM-B-1000	28.28	718	18.00	457
KKB319AM	7-319AM-B-1000	28.28	718	23.65	601
KKB225AM	7-225AM-B-1000	34.12	867	20.16	512
KKB325AM	7-325AM-B-1000	34.12	867	26.85	682
KKB136AM	7-136AM-B-1000	45.50	1155	11.70	297
KKB236AM	7-236AM-B-1000	45.50	1155	18.80	478
KKB336AM	7-336AM-B-1000	45.50	1155	25.90	658
KKB436AM	7-436AM-B-1000	45.50	1155	33.06	840

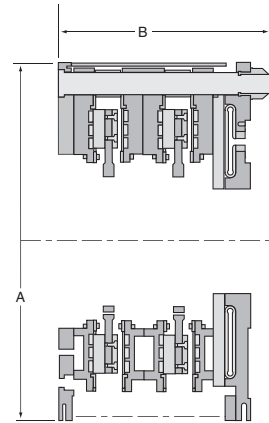

Specifications

Model Size ATD-	Assembly Number	Dynamic Torque Capacity with Standard Linings (optional linings available)				Heat Capacity			Rect. Key in/mm
		lb.in.		Nm		Series	Parallel	Max Bore	
		80 PSI	100 PSI	5.5 BAR	7 BAR	Water Hosing HP/kW	Water Hosing HP/kW	Water Hosing HP/kW	
KKB119AM	7-119AM-B-1000	66,500	83,100	7,500	9,380	93/69	185/138	5.50/140	
KKB219AM	7-219AM-B-1000	133,000	166,300	15,000	18,700	185/135	370/276	5.50/140	
KKB319AM	7-319AM-B-1000	199,500	249,000	22,500	28,100	278/207	555/414	5.50/140	
KKB225AM	7-225AM-B-1000	264,000	330,000	29,800	37,200	350/261	700/522	8.13/207	
KKB325AM	7-325AM-B-1000	396,000	495,000	44,700	55,900	600/447	1200/895	8.13/207	
KKB136AM	7-136AM-B-1000	322,000	402,000	36,300	45,400	425/317	850/633	8.13/207	
KKB236AM	7-236AM-B-1000	644,000	805,000	72,700	90,900	875/652	1750/1304	9.00/229	
KKB336AM	7-336AM-B-1000	966,000	1,208,000	109,100	136,400	1275/950	2550/1900	9.00/229	
KKB436AM	7-436AM-B-1000	1,288,000	1,611,000	145,600	182,000	1700/1260	3400/2535	9.00/229	

Mounting Hole Pattern

Model	øA		øB		øC		Hole Circle		PLT THK	
	in.	mm	in.	mm	in.	mm	in.	mm	in.	mm
19	28.28	718	11.00	279	.656	17	25.50	648	1.38	35
25	34.12	867	16.70	424	.656	17	31.00	787	1.38	35
36	45.50	1156	16.75	425	1.06	27	42.72	1085	1.38	35

AquaMaKKs Clutches and Brakes

Exploded View

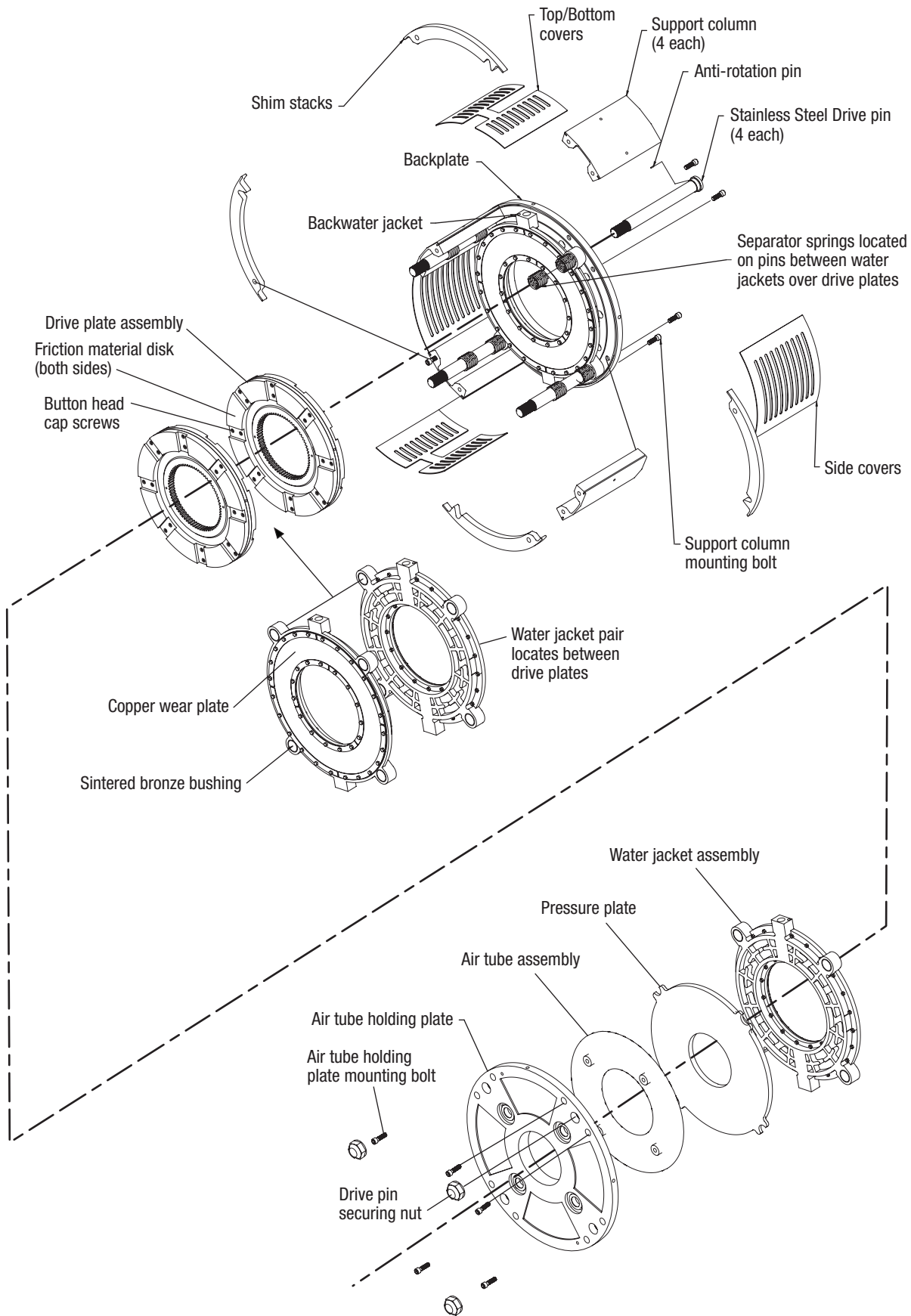

Custom Engineered Solutions with Wichita

With Wichita Clutch, you get more than just a water cooled brake, you can get a turnkey solution. Whether you need a brake painted a preferred color, water connection kits, covers, shaft assemblies, or deck mount assemblies, Wichita will provide a custom engineered solution to meet your specific needs. Call Wichita today for more information.

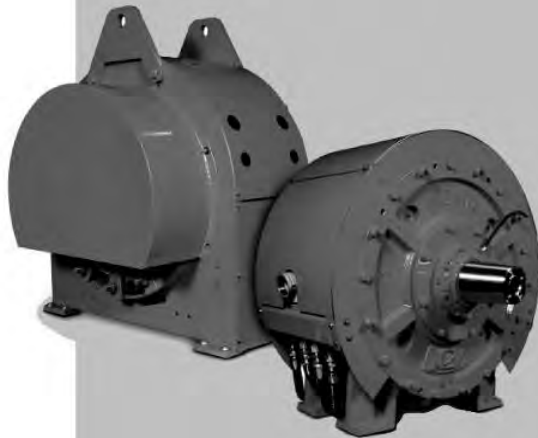

For assistance, please call, +44 (0) 1234 350 311

For after hours emergency service, call +44 (0) 1234 324 324

Custom Engineered Solutions with Wichita

With Wichita Clutch, you get more than just a water cooled brake, you can get a turnkey solution. Whether you need a brake painted a preferred color, water connection kits, covers, shaft assemblies, or deck mount assemblies, Wichita will provide a custom engineered solution to meet your specific needs. Call Wichita today for more information.



Genuine Wichita Replacement Parts

When you specify genuine replacement parts from Wichita Clutch, you automatically expect more... and get more. Especially better performance, longer life, and the peace of mind that comes with knowing that you are working with the industry's proven leader.

We have years of experience in building value into every Genuine Wichita Replacement Part. Our parts, made with quality materials and leading-edge technology, are long lasting, resulting in lower life cycle costs, they also fit precisely to give you the assurance of trouble-free performance.

We offer a three-year warranty on our line of replacement airtubes, and a two-year warranty on all other non-wear components. That's unmatched by anyone in our industry!



For assistance, please call, +44 (0) 1234 350311

For after hours emergency service, call +44 (0) 1234 324324

All Customer Service phone numbers shown in bold

Electromagnetic Clutches and Brakes

Warner Electric

Electromagnetic Clutches and Brakes

New Hartford, CT - USA
1-800-825-6544

For application assistance:
1-800-825-9050

St Barthelemy d'Anjou, France
+33 (0) 2 41 21 24 24

Precision Electric Coils and Electromagnetic Clutches and Brakes

Columbia City, IN - USA
1-260-244-6183

Matrix International

Electromagnetic Clutches and Brakes, Pressure Operated Clutches and Brakes

Brechin, Scotland
+44 (0) 1356 602000

New Hartford, CT - USA
1-800-825-6544

Inertia Dynamics

Spring Set Brakes; Power On and Wrap Spring Clutch/Brakes

New Hartford, CT - USA
1-800-800-6445

Overrunning Clutches

Formsprag Clutch

Overrunning Clutches and Holdbacks

Warren, MI - USA
1-800-348-0881 – Press #1

For application assistance:
1-800-348-0881 – Press #2

Marland Clutch

Roller Ramp and Sprag Type Overrunning Clutches and Backstops

Burr Ridge, IL - USA
1-800-216-3515

Stieber Clutch

Overrunning Clutches and Holdbacks

Heidelberg, Germany
+49 (0) 6221 30 47 0

Engineered Couplings

Ameridrives Couplings

Mill Spindles, Ameriflex, Ameridisc

Erie, PA - USA
1-814-480-5000

Gear Couplings

San Marcos, TX - USA
1-800-458-0887

Bibby Transmissions

Disc, Gear, Grid Couplings, Overload Clutches

Dewsbury, England
+44 (0) 1924 460801

Boksburg, South Africa
+27 11 918 4270

TB Wood's

Elastomeric Couplings

Chambersburg, PA - USA
1-888-829-6637 – Press #5

For application assistance:
1-888-829-6637 – Press #7

General Purpose Disc Couplings

San Marcos, TX - USA
1-888-449-9439

Ameridrives Power Transmission

Universal Joints, Drive Shafts, Mill Gear Couplings

Green Bay, WI - USA
1-920-593-2444

Huco Dynatork

Precision Couplings and Air Motors

Hertford, England
+44 (0) 1992 501900

Charlotte, NC - USA
1-800-825-6544

Linear Products

Warner Linear

Linear Actuators

Belvidere, IL - USA
1-800-825-6544

For application assistance:
1-800-825-9050

St Barthelemy d'Anjou, France
+33 (0) 2 41 21 24 24

Heavy Duty Clutches and Brakes

Wichita Clutch

Pneumatic Clutches and Brakes

Wichita Falls, TX - USA
1-800-964-3262

Bedford, England
+44 (0) 1234 350311

Twiflex Limited

Caliper Brakes and Thrusters

Twickenham, England
+44 (0) 20 8894 1161

Industrial Clutch

Pneumatic and Oil Immersed Clutches and Brakes

Waukesha, WI - USA
1-262-547-3357

Gearing

Boston Gear

Enclosed and Open Gearing, Electrical and Mechanical P.T. Components

Charlotte, NC - USA
1-800-825-6544

For application assistance:
1-800-816-5608

Nuttall Gear and Troldoy Worm Gear

Worm Gear and Helical Speed Reducers

Niagara Falls, NY - USA
1-716-298-4100

Belted Drives and Sheaves

TB Wood's

Belted Drives

Chambersburg, PA - USA
1-888-829-6637 – Press #5

For application assistance:
1-888-829-6637 – Press #7

Engineered Bearing Assemblies

Kilian Manufacturing

Engineered Bearing Assemblies

Syracuse, NY - USA
1-315-432-0700

Asia Pacific Sales Offices

Australia

Unit 51/9, Hoyle Avenue
Castle Hill, NSW 2154

+61 2 9894 0133

+61 2 9894 0368 (Fax)

www.warnerelectric.com.au

China - Hong Kong

Room 304A, 3rd Floor
Join-In Hang Sing Centre

71-75 Container Port Rd.

Kwai Chung, Hong Kong

+852 2615 9313

+852 2615 9162 (Fax)

www.warnerelectric.com.hk

China - Shanghai

Shanghai Universal Mansion
Suite 703, 168 Yuyuan Road,

Shanghai 200040

+86 21 5169-9255

+86 21 6248 5387 (Fax)

www.altramotion.com.cn

China - Taiwan

3rd Fl., No. 35, Lane 32
Kwang-Fu, South Road

10562 Taipei

+886 2 2577 8156

+886 2 2570 6358 (Fax)

www.warnerelectric.com.tw

Singapore

39 Benoi Road

Singapore 627725

+65 6487 4464

+65 6487 6674 (Fax)

www.warnerelectric.com.sg

Thailand

178 Soi Anamai Srinakarin Rd.,
Suanluang Bangkok 10250

+66 2 322 5527

+66 2 320 2380 (Fax)

www.warnerelectric.co.th

For more information, or to contact authorized agents in Japan, Korea, India, or elsewhere in Asia Pacific, send an email to: ap@altramotion.com



www.wichitaclutch.co.uk

Amphill Road
Bedford MK42 9RD UK
+44 (0) 1234 350 311
+44 (0) 1234 350 317