

# ACTUATOR LA36

## Features:

- 12, 24 or 36 V DC Permanent magnetic motor with resetable thermal overload protection
- Thrust from 500 N - 10.000 N depending on gear ratio and spindle pitch
- 10.000 N actuator cannot be ordered without electrical endstop
- 10.000 N actuator can be ordered in push now and pull from 01-09-207
- Max. speed up to 160 mm/sec. depending on load and spindle pitch
- Heavy duty aluminium housing for harsh conditions
- Highly efficient acme thread spindle
- Protection class: IP66 for outdoor use (dynamic), furthermore the actuator can be washed down by a high pressure cleaner (IP69K - static)
- Hand crank for manual operation
- Mechanical overload protection through integrated slip clutch (adjusted to 1.2 - 1.5 times max. load)
- Integrated brake, high self-lock ability
- End play – 2 mm max.
- Non rotating piston rod eye (turnable 0-90 degrees)
- Back fixture turnable in steps of 30 degrees

## Options:

- Built in end stop switches
- Adjustable magnetic sensors for end stop signals (code no. 1017031)
- Hall effect sensor with A/B –signal
- Potentiometer full scale at 333 mm stroke with 8 mm pitch, 500 mm stroke with 12 mm pitch and 833 mm with 20 mm pitch
- Different back fixtures and piston rod eyes
- Exchangeable cables in different lengths

## Usage:

- Duty cycle at max. load 20% (up to 600 mm stroke, for strokes between 601-999 mm the max. duty cycle is 15%) at ambient temperature 25°C
- Ambient operating temperature -30°C to +65°C full performance from 5 - 40°C



TECHLINE™  
IMPROVING FLEXIBILITY

LA36 is ideal for use in harsh conditions. It is our most solid actuator based on the philosophy that it must be able to operate under extreme conditions. The actuator is ideal for mobile "off-highway" equipment such as agricultural, forestry and construction machines.

## Technical specifications

### LA36 with 12V motor

Order number	Push max. (N)	Pull max. (N)	*Self-lock min. (N) Push	*Self-lock min. (N) Pull	Pitch (mm/spindle rev.)	Typical speed (mm/s) Load		Standard stroke lengths (mm) In steps of 50 mm	Typical amp. (A) 12 V	
						no	full		No load	Full load
362CXXXXXXXXXX	10000	10000	13000	13000	8	11	7	100 - 999*	4.5	22
363AXXXXXXXXXX	2600	2600	3400	3400	12	40.7	30.6	100 - 999	4.5	21
363BXXXXXXXXXX	4500	4500	5800	5800	12	23.1	17.8	100 - 999*	4.5	20.7
363CXXXXXXXXXX	6800	6800	8800	8800	12	15.5	11.9	100 - 999*	4.5	21
365AXXXXXXXXXX	1700	1700	2200	2200	20	68	52	100 - 999	4.5	22
365FXXXXXXXXXX	500**	500**	1000	1000	20	160	135	100 - 999	4.5	20

### LA36 with 24V motor

Order number	Push max. (N)	Pull max. (N)	*Self-lock min. (N) Push	*Self-lock min. (N) Pull	Pitch (mm/spindle rev.)	Typical speed (mm/s) Load		Standard stroke lengths (mm) In steps of 50 mm	Typical amp. (A) 24 V	
						no	full		No load	Full load
362CXXXXXXXXXX	10000	10000	13000	13000	8	11	7	100 - 999*	Not tested	
363AXXXXXXXXXX	2600	2600	3400	3400	12	41	32.3	100 - 999	2.4	10.4
363BXXXXXXXXXX	4500	4500	5800	5800	12	23.3	18.9	100 - 999*	2.4	10.2
363CXXXXXXXXXX	6800	6800	8800	8800	12	15.7	12.7	100 - 999*	2.4	10.3
365AXXXXXXXXXX	1700	1700	2200	2200	20	68	52	100 - 999	2.4	10.3
365FXXXXXXXXXX	500**	500**	1000	1000	20	160	135	100 - 999	2.4	10.0

### LA36 with 36V motor

Order number	Push max. (N)	Pull max. (N)	*Self-lock min. (N) Push	*Self-lock min. (N) Pull	Pitch (mm/spindle rev.)	Typical speed (mm/s) Load		Standard stroke lengths (mm) In steps of 50 mm	Typical amp. (A) 36 V	
						no	full		No load	Full load
362CXXXXXXXXXX	10000	10000	13000	13000	8	11	7	100 - 999*	Not tested	
363AXXXXXXXXXX	2600	2600	3400	3400	12	41	33.5	100 - 999	2.0	8.0
363BXXXXXXXXXX	4500	4500	5800	5800	12	23.3	19.1	100 - 999*	2.0	8.0
363CXXXXXXXXXX	6800	6800	8800	8800	12	15.7	12.8	100 - 999*	2.0	8.0
365AXXXXXXXXXX	1700	1700	2200	2200	20	68	52	100 - 999	2.0	8.0
365FXXXXXXXXXX	500**	500**	1000	1000	20	160	135	100 - 999	2.0	8.0

\* There are limitations on the stroke length if you need full load, please see " LA36 Load v. Stroke Length" on page 2.

\*\* Note: Fully loaded actuators need a softstart in order to prevent the clutch slipping at start (see curves).

### Speed and current curves:

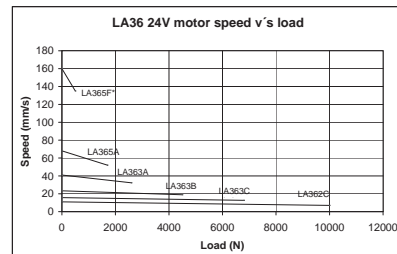
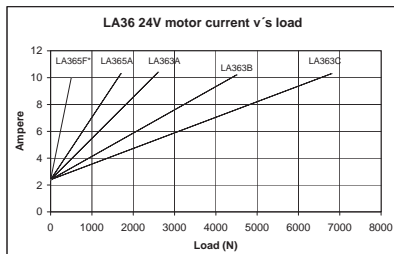
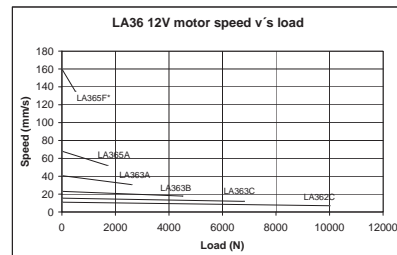
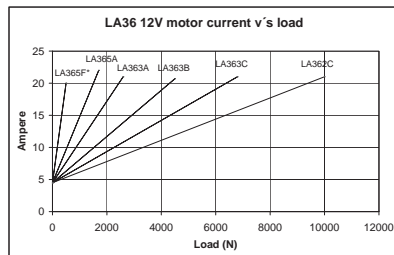

10.000N not tested

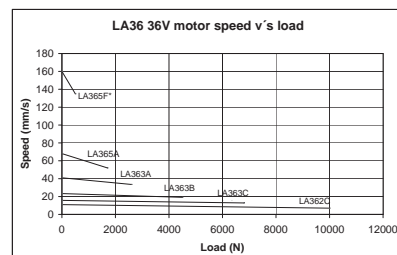
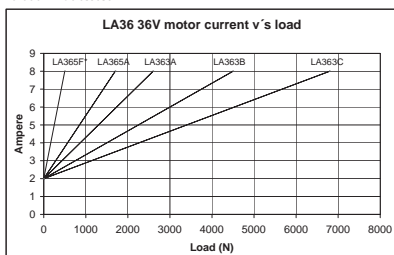

10.000N not tested

# LA36

## Ordering example:

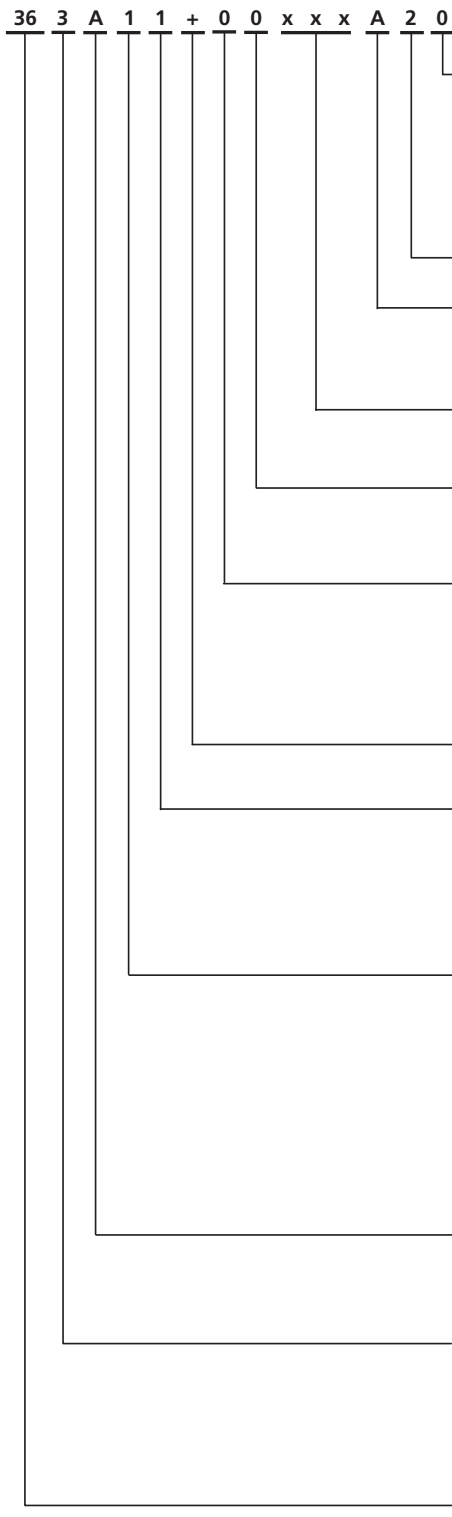

**Cable:**

- 0 = No cable
- 1 = 1.5 m power cable (0367002-1500)
- 2 = 5 m power cable (0367002-5000)
- 3 = 0.2 m power cable with AMP connector (0367006)
- 4 = 1.5 m power and 1.5 signal (0367002-1500+0367003-1500)
- 5 = 5 m power and 5 m signal (0367002-5000+0367003-5000)
- 6 = 1.5 m Y-cable, power and signal in one (0367020)

**IP-degree:**

- 2 = Standard (IP66)

**Motor type:**

- A = 12 V DC with clutch
- B = 24 V DC with clutch
- C = 36 V DC with clutch

**Stroke length:**

- XXX = mm Acme spindle:  
100, 150...999 mm

**Feedback:**

- 0 = Standard (No feedback)
- H = Hall signal
- P = Potentiometer (not possible with CS36)

**End stop:**

- 0 = No limit switches (not for spindle 2 and A)
- 1 = With limit switches
- 2 = With limit switches and end-stop signals
- 3 = CS36
- 4 = CS36 with end-stop signals
- 5 = With potential free limit switches

**Safety nut:**

- + = Without safety nut - Standard
- S = With safety nut - only in push

**Piston rod eye:**

- 0 = M20 X 1 female adapter - 0361016
- 1 = ø 12.9 mm hole, for 1/2" pin - 0361018-B
- 2 = ø 12.2 mm hole, for 12 mm pin - 0361109-B
- 3 = M12 X 1.75 male adapter - 0361224
- 4 = M16 X 1.75 male adapter - 0361135
- 5 = ø 12.2 hole with slot (like LA34) - 0361138

**Back fixture:**

- 0 = M20 X 1 female adapter - 0361128
- 1 = ø 12.9 mm hole, for 1/2" pin - 0361129
- 2 = ø 12.9 mm hole turned 90°, for 1/2" pin - 0361129
- 3 = ø 12.2 mm hole, for 12 mm pin - 0361119
- 4 = ø 12.2 mm hole turned 90°, for 12 mm pin - 0361119
- 5 = M12 X 1.75 male adapter - 0361126
- 6 = M16 X 1.75 male adapter - 0361247
- 7 = ø 12.2 hole with slot (like LA34) - 0361140
- 8 = ø 12.2 hole with slot (like LA34) turned 90° - 0361140

**Gearbox:**

	8 mm pitch	12 mm pitch	20 mm pitch
A = Gear ratio 1 : 18	N.A.	2.600 N	1.700 N
B = Gear ratio 1 : 31	N.A.	4.500 N	N.A.
C = Gear ratio 1 : 46	10.000 N	6.800 N	N.A.
F = Gear ratio 1 : 7	N.A.	N.A.	500 N

**Spindle type:**

- 2 = 2-threaded acme spindle (8mm pitch)
- 3 = 3-threaded acme spindle (12 mm pitch)
- 5 = 5-threaded acme spindle (20 mm pitch)
- A = 2+adjustable reed limit switches (on outer tube)
- C = 3 + adjustable reed limit switches (on outer tube)
- E = 5 + adjustable reed limit switches (on outer tube)

**Actuator type:**

- 36 = LA36

LA36 dimensions:

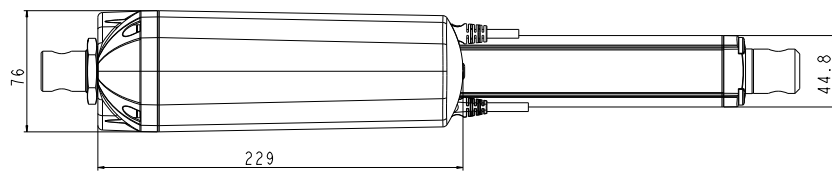
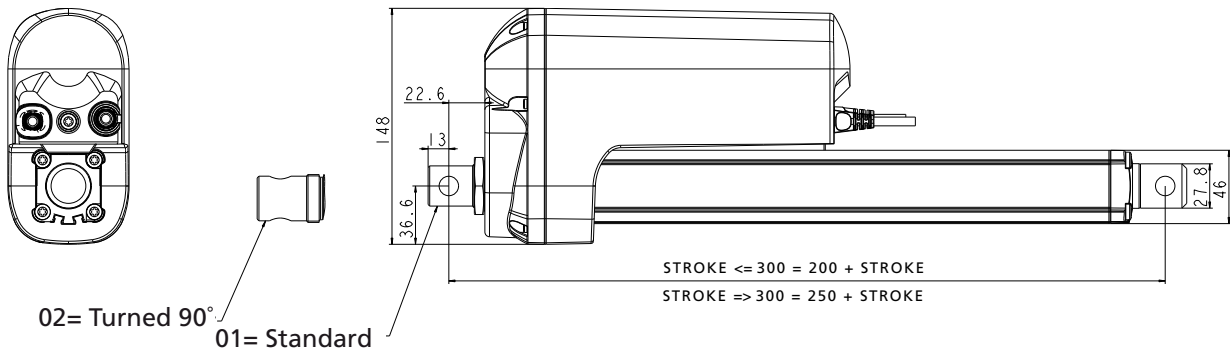

LA36 with adapter:

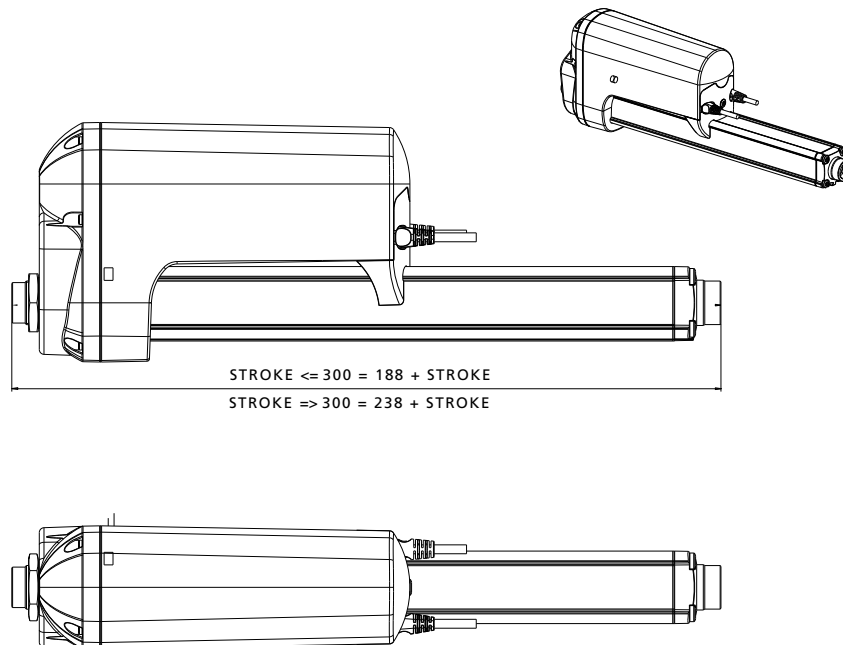

Adapter part number: 0361016 and 0361015

**Connections diagram:**

For 36xxxx+0H/Pxxxxxx and 36xxxx+1H/Pxxxxxx

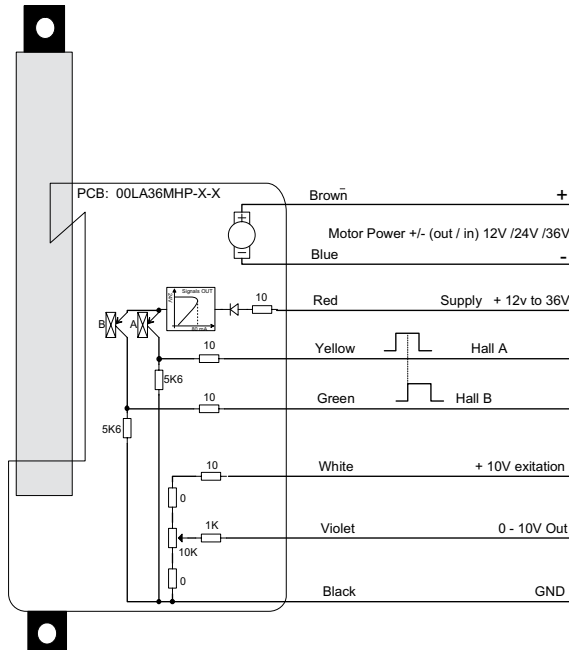

**Connections diagram:**

For 36xxxx+ 2Pxxxxxx and 36xxxx+20xxxxxx

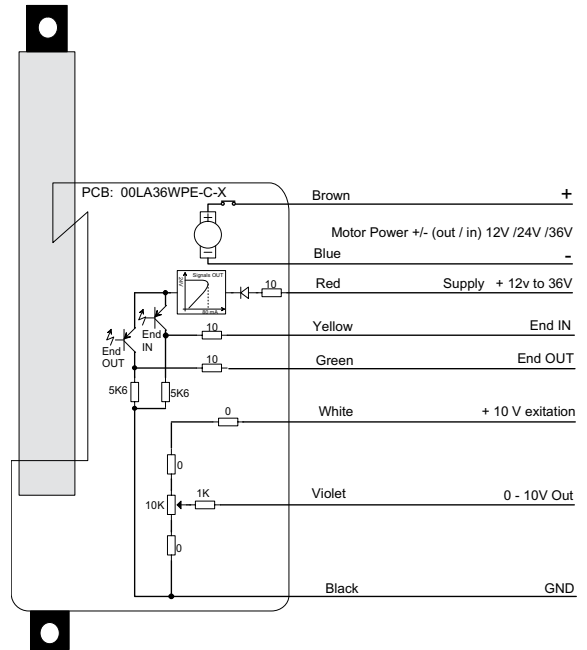

**Connections diagram:**

For 36xxxx+30xxxB20, 36xxxx+3HxxxB20 and 36xxxx+40xxxB20

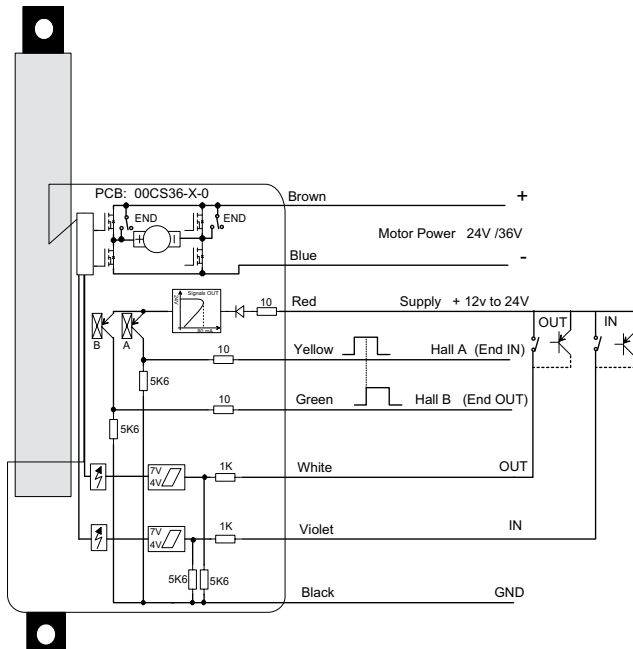

**Connections diagram:**

For 36xxxx+2Hxxxxxx

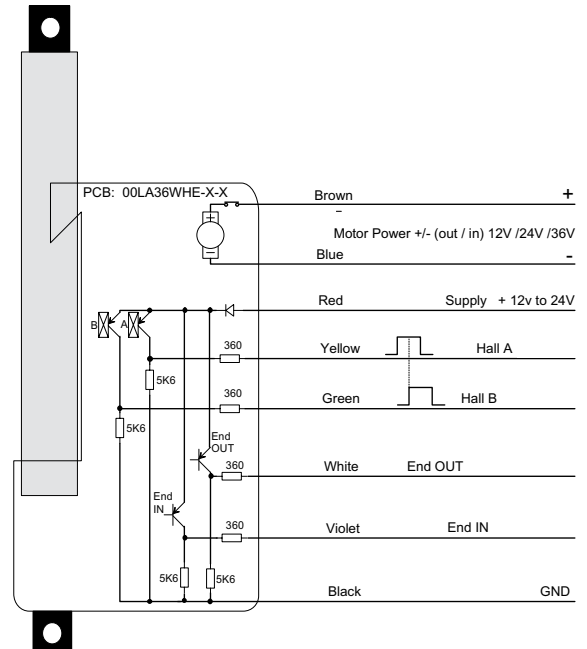

**Note:** If you wish to use the endstop signals, you will have to keep power on the brown and blue wires, otherwise the signal will be lost.

**Connections diagram:**  
For 36xxxxx50xxxxxx

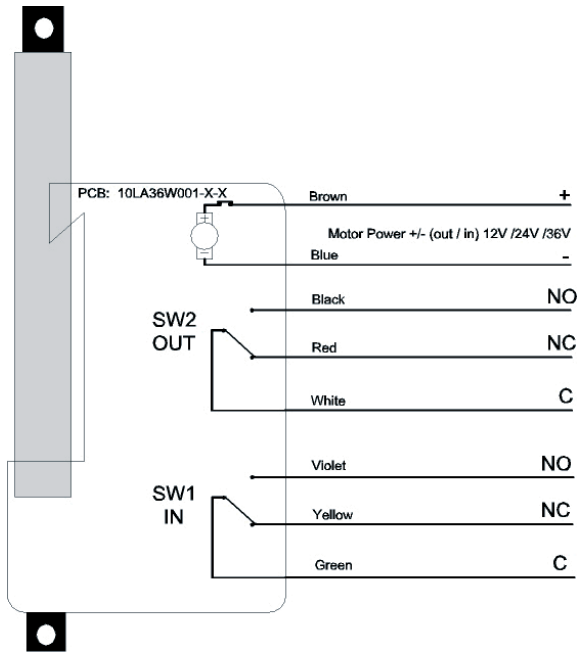

**I/O specifications: Power supply - Motor**

Item	Specification	Comment
<b>Power supply</b>		
Input voltage	12 VDC, $\pm 20\%$ 24 VDC, $\pm 10\%$ 36 VDC, $\pm 10\%$	Cable dimension: 2 x 2.5mm <sup>2</sup> (2 x AWG14) for all different voltages.
Duty cycle	20% at max. load	Ambient temperature 25°C
Input current	2 - 21 Amp. depending on load and voltage (see graphs)	
Connection	To extend actuator: Connect Brown to positive Connect Blue to negative  To retract actuator: Connect Brown to negative Connect Blue to positive	Actuator direction can be controlled with a double-throw switch with the middle position "off"

**Note:** Please note on variants with fast gear (500N-LA365F), it is necessary to use soft start to avoid the actuator clutch slipping when started.

**Positioning feedback – Potentiometer.**

Item	Specification	Comment
Absolute positioning		
Potentiometer	Bourns 0 - 10 K ohm A 5%, 10-Turn	Type: 3540 Wirewound
Output range with 8 mm spindle pitch	0 K ohm = 0 mm stroke 10 K ohm = 333 mm stroke	The same for all LA36 8mm models. e.g. 166.6 mm stroke = 5 Kohm
Output range with 12 mm spindle pitch	0 K ohm = 0 mm stroke 10 K ohm = 500 mm stroke	The same for all LA36 12 mm models. e.g. 250 mm stroke = 5 Kohm
Output range with 20 mm spindle pitch	0 K ohm = 0 mm stroke 10 K ohm = 833 mm stroke	The same for all LA36 20 mm models. e.g. 416.5 mm stroke = 5 Kohm
Linearity	$\pm 0.25\%$	
Output protection	1 Kohm protection resistor	

**Note:** Please note that Potentiometer is not possible on variants with fast gear (LA365F) -500N.

Positioning feedback – Hall sensors.

Item	Specification	Comment
Relative positioning		
Signal description	Can be used for both direction and positioning	
Input Voltage	12 - 36 V DC	Cable dimension: 6 x 0.5 mm <sup>2</sup> (6 x AWG20) for all different voltages
Output voltage	Always the same as input voltage Note: max. output voltage 24 V DC	
Resolution (Distance the piston rod moves per count)	10000 N: Actuator = 0.124138 mm per count 6800 N: Actuator = 0.165517mm per count 4500 N: Actuator = 0.253846 mm per count 2600 N: Actuator = 0.432558 mm per count 1700 N: Actuator = 0.72093 mm per count  Movement per single Hall pulse: 10000 N Actuator = 0.496551 mm per pulse 6800 N Actuator = 0.662068 mm per pulse 4500 N Actuator = 1.015384 mm per pulse 2600 N Actuator = 1.730232 mm per pulse 1700 N Actuator = 2.88372 mm per pulse	The Hall sensor signals are generated by the turning of the actuator gearing These signals can be fed into a PLC (Programmable Logic Controller). In the PLC the quadrature signals (fig. 1) can be used to register the direction and position of the piston rod
Frequency	Frequency is 14 - 26 Hz on A signal (and the same on B signal) depending on load	Low frequency with a high load Higher frequency with no load
Current consumption	15 mA	Also when actuator is not running
Switching capacity	40 mA, max. pr. channel	Max. 680 nF
Connection	Supply = Red Hall A = Yellow Hall B = Green Common - = Black	
Diagram:	<p style="text-align: right;">Fig. 1</p>	

Available Circuits (LINAK code 1017031):

		415A3
Connection Code		V
Cable code		108
Circuit style		B
Contact		N.O.
Connection		PNP
Indication		LED
Voltage V DC		5...30
Voltage V AC		5...30
Max voltage drop	V	0.1
Max power	W	10
Max current	mA	50
Varistor	V	-
Cable size	mm <sup>2</sup>	3 x 0,14
Sheath		PVC

Circuit styles:

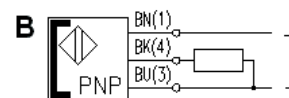

## Manual hand crank

The manual hand crank can be used in the case of power failure.

The cover over the Allen Key socket must be unscrewed before the Allen Key can be inserted and the Hand Crank operated.

Hand Crank Torque: 6 - 8 Nm (at maximum load)

Piston Rod movement per turn	Gear A = 10.5 mm
	Gear B = 6.0 mm
	Gear C = 4.0 mm
	Gear F = 27 mm

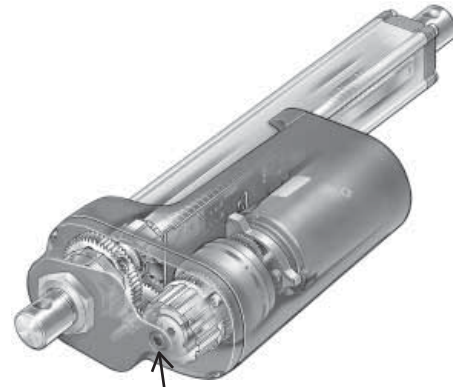

6 mm Allen key



The power supply has to be disconnected during manual operation.



If the actuator is operated as a Hand crank, it must be operated by hand or carefully by machine, otherwise there is a potential risk of overloading and hereby damage actuator.

## The LA36 is tested according to the following standards:

Test	Specification:	Comment
Cold test	EN60068-2-1 (Ab) EN60068-2-1 (Ad)	Storage at low temperature: -40°C Operating at low temperature: -30°C
Dry heat	EN60068-2-2 (Bb) EN60068-2-2 (Bd)	Storage at high temperature: +90°C Operating at high temperature: +60°C
Change of temperature	EN60068-2-14 (Na)	Rapid change in temperature: +100°C to -30°C
Damp heat	EN60068-2-30 (Db) EN60068-2-3 (Ca)	Damp heat, Cyclic: Relative humidity 93 - 98 % High +55°C, low +25°C Damp heat, Steady: Relative humidity 93 - 95 % +40°C ± 2°C
Salt spray	EN60068-2-52 (Kb)	Salt spray test: 500 hours incl. spraying periods + humidity storage
Degrees of protection	EN60529-IP66	IP6X – Dust: Dust-tight IPX6 – Water: No ingress of water causing damage
Chemicals	BS7691/96 hours	Resistant against: diesel, hydraulic oil, ethylene glycol, urea nitrogen, liquid lime, NPK fertilizers
Free fall		Free fall from all sides: 0.4 meters on to steel
Vibration	EN60068-2-36 (Fdb) EN60068-2-6 (Fc)	Random vibration: Short time 6.29 g RMS (Rod Mean Square) Long time 7.21 g RMS Sinus vibration: Freq. 5 - 25 Hz, amplitude = 3.3 mm pp Freq. 25 - 200 Hz, acceleration 4 g
Bump	EN60068-2-29 (Eb)	Bump test: Level 40 g for 6 milliseconds. 3,000 bumps
Shock	EN60068-2-27 (Ea)	Shock test: Level 100 g for 6 milliseconds
Power supply	ASAE EP455 (1990)	Operating voltages: +10 V - + 16V Over voltage +26(V) / 5 min
HF-immunity	EN61000-6-2	Level: 30V/m. at 26 MHz – 1000 MHz; 80% 1 KHz
Emission	EN61000-6-4	All levels are well within the norms of the emission standards
Insulation test		Level: 500 V AC/25-100 Hz for 1 minute
Automotive transients	ISO 7637	Load dump test only accepted on motor power connection

Specifications subject to change without prior notice.

It is the responsibility of the product user to determine the suitability of LINAK A/S products for a specific application. LINAK will at point of delivery replace/repair defective products covered by the warranty if promptly returned to the factory. No liability is assumed beyond such replacement/repair.