

Application Guide Overtuning Clutches

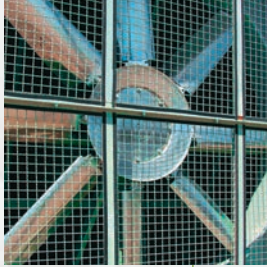

 **Formsprag**[®]
Clutch

An Altra Industrial Motion Company

Formsprag Clutch

Broadest Range of Overrunning Clutches

With over 50 years of experience, Formsprag has applied catalog standard clutches as well as many special designs (typically driven by OEM requirements) into a wide variety of markets. This has resulted into expanding the product offering into the broadest range of overrunning clutches in the world. Over 2,000 different products are available with catalog designs ranging from 1 to 720,000 lb.ft. of torque capacity, clutch bores from 0.1 inches to over 20.0 inches and overrunning applications operating up to 50,000 RPM in jet engines.

Formsprag overrunning clutches can be found in every corner of the world with applications in commercial, aircraft and military equipment. These applications include backstopping clutches in many gear reducers, snow ski lifts, amusement park rides, automotive final assembly lines, steel stamping presses, fan and pump drives, corrugated box making, material handling in foundries and steel making, forming and pickling, and marine applications such as submarines.

Formsprag Clutches are available for three basic types of applications:

Overrunning, **Indexing**, and **Backstopping**.

Rebuild and Overhaul Service

Send us your old clutches and we'll make them like new again.

With the same wear life as original products at rebuild cost.

The difference is not just cosmetic.

All internal components – sprags, energized springs, retainer, bearings, seal and hardware are refurbished or replaced to new performance standards. The inner and outer races are ground to specifications noted below so that no wear patterns remain.

- Sprag Surface is hardened to 58-62 Rc
- Sprag Surface finish is 15-25 microinches
- Sprag Surface taper limit is 0.0002 inch per inch

Consider these advantages

Price – A guaranteed savings of at least 30% or more versus new product.

Speed – Clutches are received, inspected and rebuilt in the shortest possible time frame.

Warranty – 1 Year on labor and materials, same as new clutches.

Emergency Breakdown Program – All products that are air freighted into the Warren plant are processed immediately and, in most cases, are able to be rebuilt within a 24-hour period. However, for applications that can't afford 'downtime', a spare clutch is recommended.



For more information call 1-800-927-3262

Marine Lifting

Bi-Directional Backstopping

Form-Lock (FL) bi-directional clutches are used on winch drives of davits on ships to provide optional manual drive to the normal drive system to smoothly raise and lower the life boats. The Form-Lock is a mechanical clutch that can be driven in both directions while automatically providing a holding brake function when the driving torque is stopped. Additional uses include the smooth raising and lowering of gun barrels in artillery, and other loads being raised and lowered smoothly with ball screws. Contact Formsprag for information and assistance.

Torque Range: 100 to 4800 lb.in.

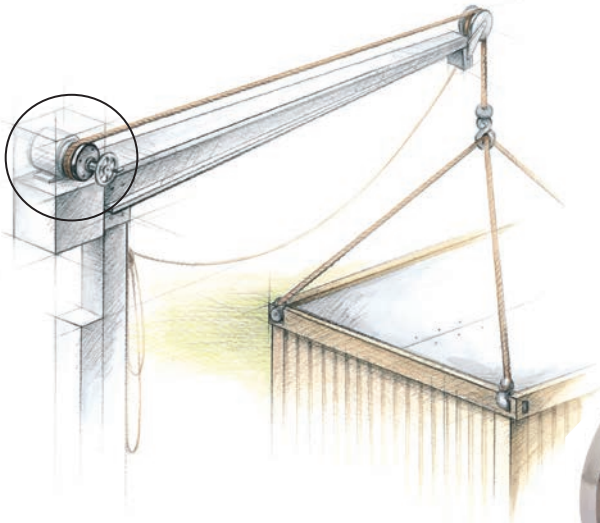

Model FL



Textile Processing

Overrunning

FSO overrunning clutches allow the feed drive to power the rollers at a low speed when threading the leading edge of a new roll of fabric. When the fabric is fully threaded and ready to be pulled at production speeds, the FSO un-clutches the feed drive allowing those same rollers to be rotated at faster speeds without back driving the lower speed feed drive.

The clutch automatically disconnects the lower speed feed drive during higher speed operation and prevents possible damage to the feed drive if back driven at the higher speeds.

Bore Range: 0.5 to 7.0 in.
Torque Range: 275 to 27,000 lb.ft.

Model FSO

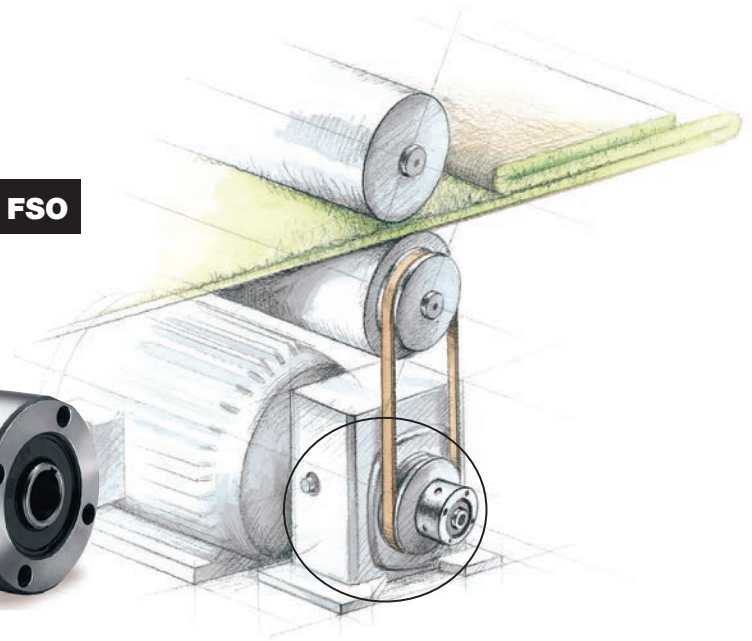

Food Conveyor Indexing Drive

Indexing

HPI clutches are mounted on the head shaft and translates the reciprocating motion from the crank mechanism into incremental motion in one direction, advancing the conveyor a uniform distance with each drive stroke and then overrunning in the opposite direction on the return stroke. These clutches are available with FDA approved food grade greases and a variety of surface coatings required for wash down duty.

Bore Range: 0.5 to 7.0 in.
Torque Range: 275 to 27,000 lb.ft.

Model HPI

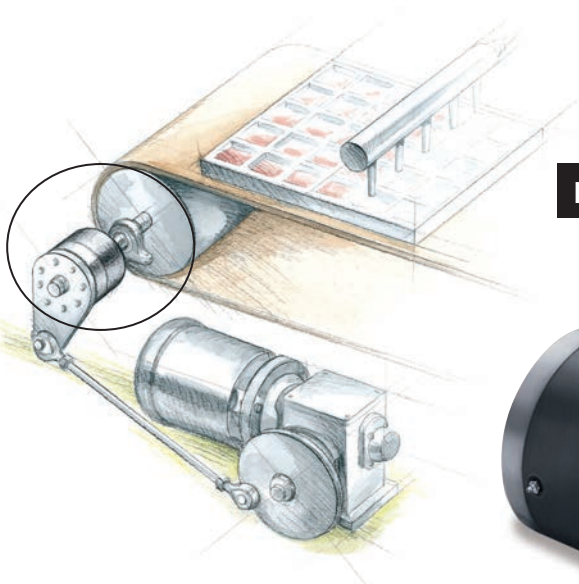
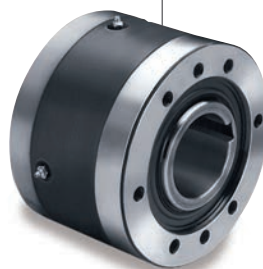

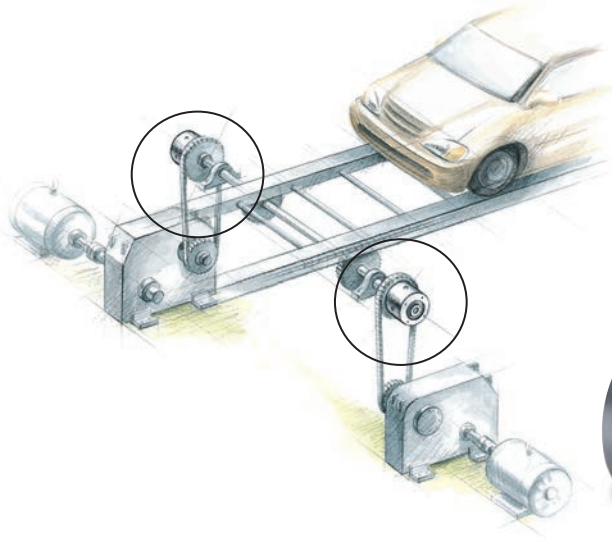

Model FSO

Assembly Line Conveyor

Overrunning

FSO overrunning clutch is mounted on the head shaft of a conveyor system to provide instantaneous switching from the primary drive to a stand-by drive to reduce down time. Mounting the FSO clutch between each drive and the conveyor provides the automatic clutching and de-clutching when switching from one drive to another without any utility or input to the clutch. Using the FSO clutch on dual drive applications reduces installation and operating costs by eliminating controls or actuation mechanisms.

Bore Range: .05 to 7.0 in.
Torque Range: 275 to 38,000 lb.ft.



Dual Drive Overrunning

FW clutch coupling is used on in-line mounting of dual drive systems of fans and pumps to provide a smooth transfer of power from one drive/power system to another (electric motor to steam turbine and gear reducer). The model FW clutch coupling mounted between the output of a steam turbine reducer and the fan allows this fan to be initially started with an electric motor without back driving the steam turbine. When steam becomes available the FW allows the steam turbine drive to come up to speed (over any amount of time) and automatically transfer power. When the speeds are matched, the starting electric motor can be turned off to save its utility cost.

Bore Range: 0.6 to 7.0 in.
Torque Range: 107 to 27,000 lb.ft.

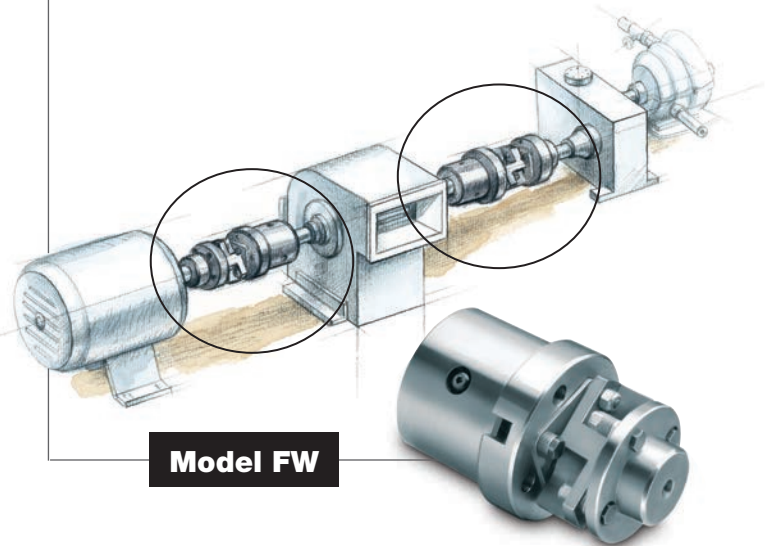

Model FW

Two Speed Conveyor Drive

Overrunning

FWW clutch coupling is used on inline mounting of creep drive conveyor systems for low speed belt inspections or cold weather low speed weekend creep operation. The FWW clutch coupling is mounted between the main drive and the low speed creep drive and provides for smooth clutching when switching from one drive to the other. Cost savings are realized at both the initial installation because no controls are required to perform the clutching and declutching function; and during operation because no set-up or wear adjustments are required so that regular maintenance costs are reduced.

Bore Range: .06 to 4.4 in.
Torque Range: 276 to 7,000 lb.ft.

Model FWW

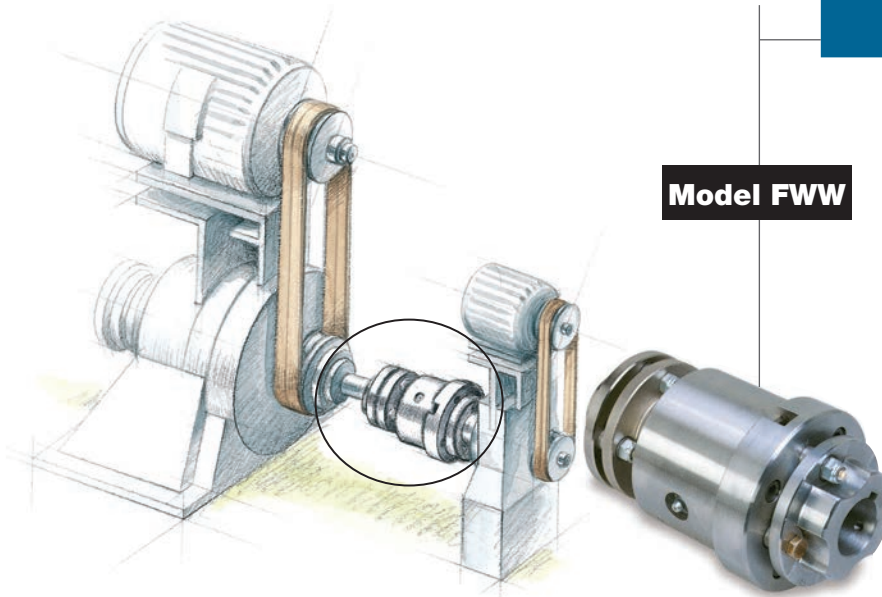

Punch Press Feed Drive

Backstopping

Model FSR

FSR clutches are used as a backstopping clutch on a press feed drive by mounting the clutch on one end of the drive roller and grounding the outer race with a torque arm. This installation allows the drive roller to rotate in only the desired direction. Press feed rollers for applications using steel and other stiff materials pulling from a coil need to resist the material's natural tendency to spring backwards or re-coil.

Bore Range: .3 to 2.19 in.
Torque Range: 40 to 1,800 lb.ft.

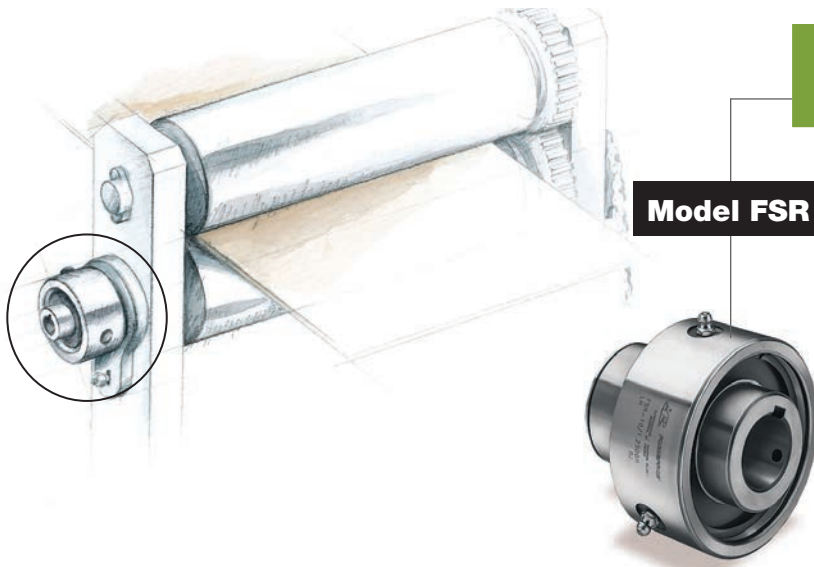

Fan Drive

Backstopping

FB clutches can be mounted directly on the shaft of the fan drive and grounded with a torque arm; the unit provides a backstop function for the fan drive. When the fan is turned off, wind flow from other fans in the system or the environment can cause the fan to rotate opposite the operating direction and the FB can eliminate this problem thereby improving the life of the fan drive systems.

Bore Range: 1.0 to 6.00 in.
Torque Range: 2.6 to 284 lb.ft.

Model FB

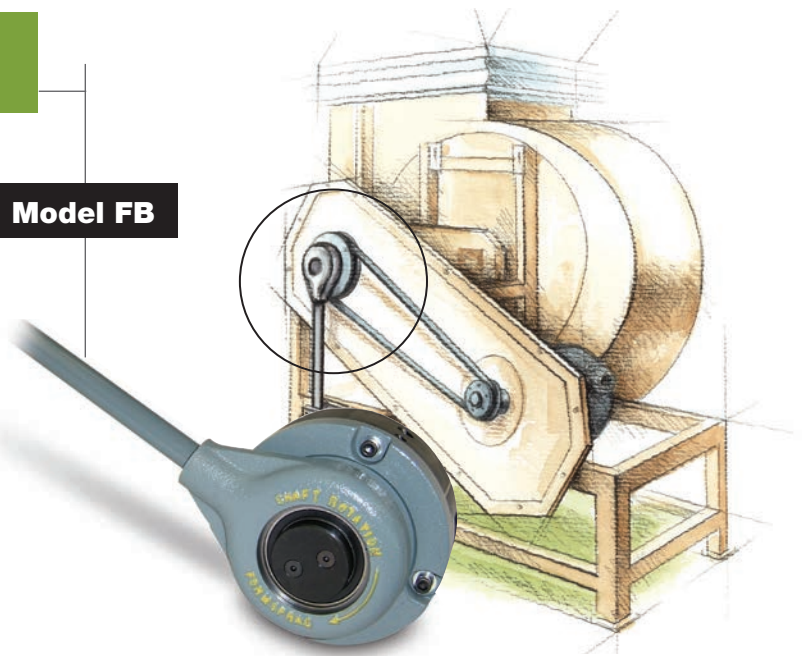

Cooling Tower Fan Drive

Backstopping

Model HSB

HSB (High Speed Backstop) clutches are used on cooling tower fan drives to prevent rotation in the opposite direction from the normal driving direction. When the fan drive is off, wind pressure from other fans or ambient breezes can apply sufficient force to rotate fan blades in the opposite direction. The HSB clutch allows the fan to freely rotate in the desired driving direction while preventing any rotation in the opposite direction.

Bore Range: .43 to 7.0 in.
Torque Range: 300 to 27,000 lb.ft.

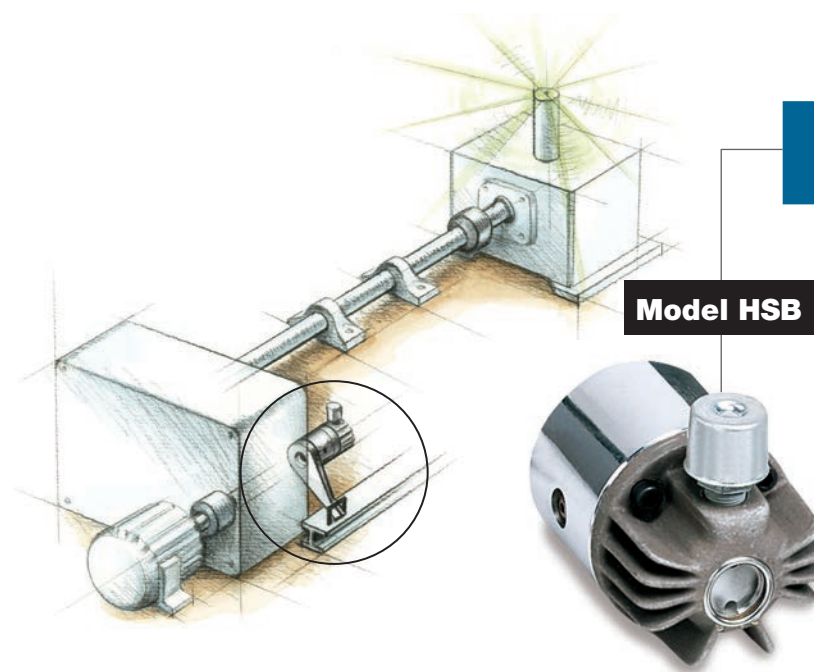

Bulk Handling Conveyor Drive

Backstopping

LLH holdback clutches are mounted on the head shaft of the conveyor, typically on the side opposite the electric motor and gear reducer. The LLH clutch allows the headshaft to freely rotate in the driving direction while preventing any rotation in the opposite direction.

Bore Range: 1.87 to 20.0 in.
Torque Range: 4,000 to 700,000 lb.ft.

Model LLH

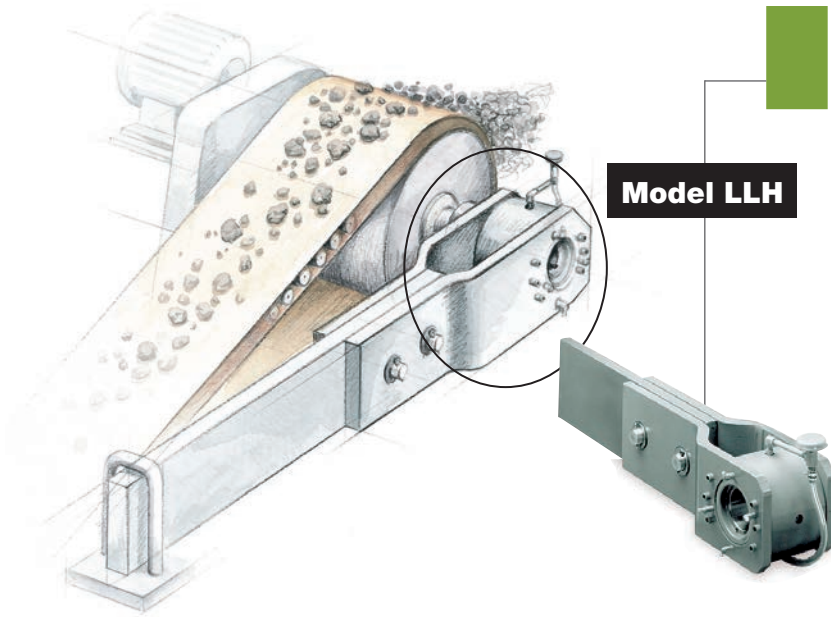

Punch Press Feed Drive

Indexing

HPI indexing clutches are used on the material feed drive of punch press machines to provide a uniform incremental rotation of the feed rollers with each stroke of the press ram. The reciprocating motion of the gear rack is translated into specific and uniform motion by the HPI clutch, advancing the correct amount of material for the next punch stroke. These clutches are available with either oil or grease lubrication.

Bore Range: 0.5 to 7.0 in.
Torque Range: 275 to 27,000 lb.ft.

Model HPI

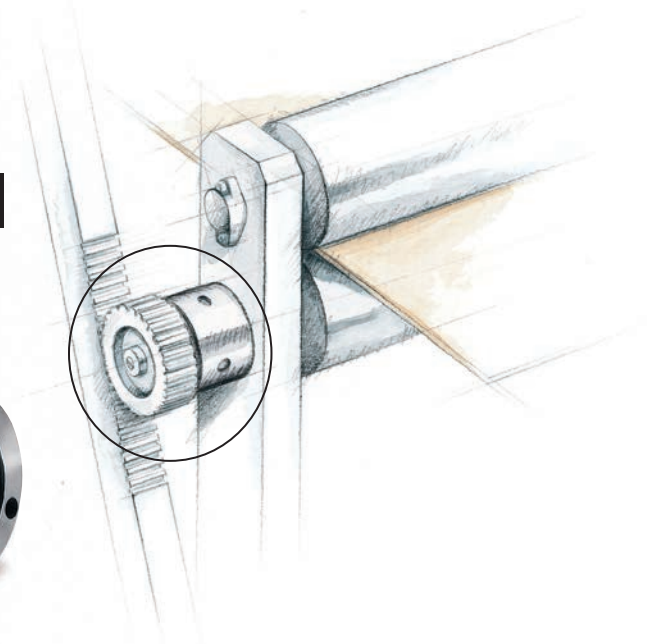

Conveyor Drive

Overrunning

FSO clutches are used on multi-speed, one direction only conveyors for non-destructive accommodation of speed differentials in powered rollers and belt drive systems. The FSO clutch allows the slower speed zone to over-speed during the transitional period without back driving the slower drive system.

Bore Range: 0.5 to 7.0 in.
Torque Range: 275 to 27,000 lb.ft.

Model FSO

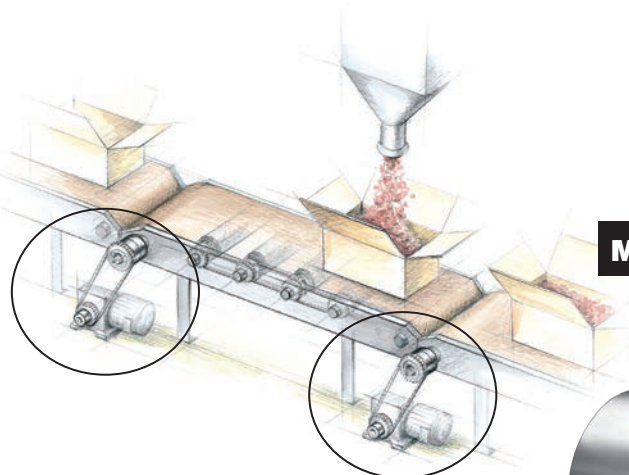

High Speed Backstopping

Backstopping

Skeet shooting enthusiasts rely on clay pigeon throwing machines using Stieber overrunning clutches to reduce costs and enjoy longer operating life. The Stieber model CSK clutch is used on clay pigeon throwing machines as a backstop to prevent oscillation of the throwing arm after each stroke. The CSK clutch allows free rotation in the throwing (or overrunning) direction and prevents any rotation in the opposite direction.

Model CSK



Bore Range: .3 to 1.57 in.
Torque Range: 2.6 to 284 lb.ft.

Pump Backstopping

Backstopping

SB Clutches are used on fluid pumping equipment to provide a backstopping function preventing any reverse rotation. In a simple electric motor/pump drive system, the SB clutch is mounted on the electric motor shaft with the output shaft of the SB clutch coupled to the pump's input shaft. The SB clutch with a torque arm attached to the outer race allows the pump to rotate only in the driving direction.

Bore Range: 1.87 to 20.0 in.
Torque Range: 4,000 to 700,000 lb.ft.

Model SB

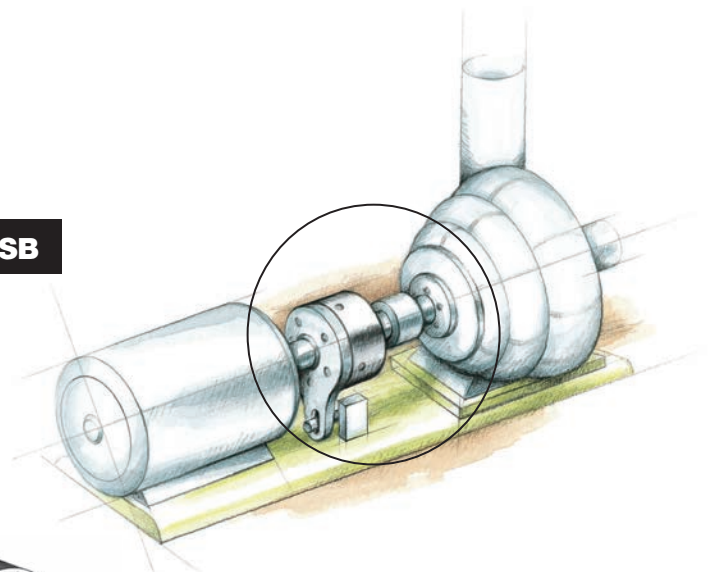

<p>Electromagnetic Clutches and Brakes</p> <p>Warner Electric <i>Electromagnetic Clutches and Brakes</i> New Hartford, CT - USA 1-800-825-6544 <i>For application assistance: 1-800-825-9050</i></p> <p>St Barthelemy d'Anjou, France +33 (0) 2 41 21 24 24</p> <p><i>Precision Electric Coils and Electromagnetic Clutches and Brakes</i> Columbia City, IN - USA 1-260-244-6183</p> <p>Matrix International <i>Electromagnetic Clutches and Brakes, Pressure Operated Clutches and Brakes</i> Brechin, Scotland +44 (0) 1356 602000 New Hartford, CT - USA 1-800-825-6544</p> <p>Inertia Dynamics <i>Spring Set Brakes; Power On and Wrap Spring Clutch/Brakes</i> New Hartford, CT - USA 1-800-800-6445</p>	<p>Couplings</p> <p>Ameridrives Couplings <i>Mill Spindles, Ameriflex, Ameridisc</i> Erie, PA - USA 1-814-480-5000</p> <p><i>Gear Couplings</i> San Marcos, TX - USA 1-800-458-0887</p> <p>Bibby Transmissions <i>Disc, Gear, Grid Couplings, Overload Clutches</i> Dewsbury, England +44 (0) 1924 460801 Boksburg, South Africa +27 11 918 4270</p> <p>TB Wood's <i>Elastomeric Couplings</i> Chambersburg, PA - USA 1-888-829-6637 – Press #5 <i>For application assistance: 1-888-829-6637 – Press #7</i></p> <p><i>General Purpose Disc Couplings</i> San Marcos, TX - USA 1-888-449-9439</p> <p>Ameridrives Power Transmission <i>Universal Joints, Drive Shafts, Mill Gear Couplings</i> Green Bay, WI - USA 1-920-593-2444</p> <p>Huco Dynatork <i>Precision Couplings and Air Motors</i> Hertford, England +44 (0) 1992 501900 Charlotte, NC - USA 1-800-825-6544</p>	<p>Heavy Duty Clutches and Brakes</p> <p>Wichita Clutch <i>Pneumatic Clutches and Brakes</i> Wichita Falls, TX - USA 1-800-964-3262 Bedford, England +44 (0) 1234 350311</p> <p>Twiflex Limited <i>Caliper Brakes and Thrusters</i> Twickenham, England +44 (0) 20 8894 1161</p> <p>Industrial Clutch <i>Pneumatic and Oil Immersed Clutches and Brakes</i> Waukesha, WI - USA 1-262-547-3357</p> <p>Gearing</p> <p>Boston Gear <i>Enclosed and Open Gearing, Electrical and Mechanical P.T. Components</i> Charlotte, NC - USA 1-800-825-6544 <i>For application assistance: 1-800-816-5608</i></p> <p>Bauer Gear Motor <i>Gearred Motors</i> Esslingen, Germany +49 (711) 3518-0</p> <p>Nuttall Gear and Delroyd Worm Gear <i>Worm Gear and Helical Speed Reducers</i> Niagara Falls, NY - USA 1-716-298-4100</p>	<p>Overrunning Clutches</p> <p>Formsprag Clutch <i>Overrunning Clutches and Holdbacks</i> Warren, MI - USA 1-800-348-0881 – Press #1 <i>For application assistance: 1-800-348-0881 – Press #2</i></p> <p>Marland Clutch <i>Roller Ramp and Sprag Type Overrunning Clutches and Backstops</i> South Beloit, IL - USA 1-800-216-3515</p> <p>Stieber Clutch <i>Overrunning Clutches and Holdbacks</i> Heidelberg, Germany +49 (0) 6221 30 47 0</p> <p>Belted Drives and Sheaves</p> <p>TB Wood's <i>Belted Drives</i> Chambersburg, PA - USA 1-888-829-6637 – Press #5 <i>For application assistance: 1-888-829-6637 – Press #7</i></p> <p>Engineered Bearing Assemblies</p> <p>Kilian Manufacturing <i>Engineered Bearing Assemblies</i> Syracuse, NY - USA 1-315-432-0700</p> <p><i>For information concerning our sales offices in Asia Pacific check our website www.altramotion.com.cn</i></p>
<p>Linear Products</p> <p>Warner Linear <i>Linear Actuators</i> Belvidere, IL - USA 1-800-825-6544 <i>For application assistance: 1-800-825-9050</i></p> <p>St Barthelemy d'Anjou, France +33 (0) 2 41 21 24 24</p>			



www.formsprag.com

23601 Hoover Road
Warren, MI 48089 - USA
586-758-5000
Fax: 586-758-5000

For Application Assistance
1-800-927-3262