

*Ameridrives Couplings*

*Ameridrives Power  
Transmission*

*Bauer Gear Motor*

*Bibby Turboflex*

*Delroyd Worm Gear*

*Formsprag Clutch*

*Marland Clutch*

*Nuttall Gear*

*TB Wood's*

# Power Transmission Solutions for the Metal Shredder Market

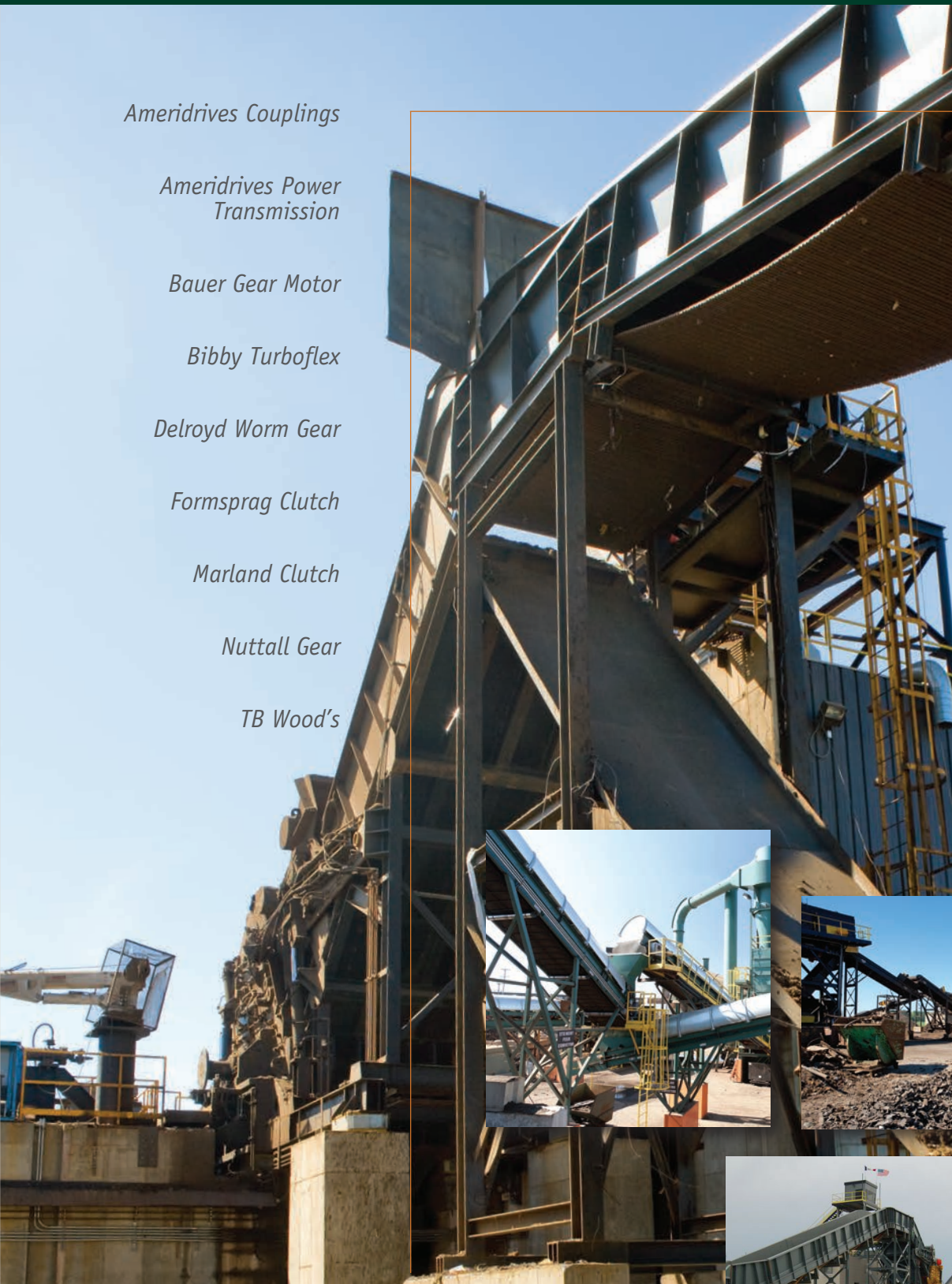

## **Altra Industrial Motion provides power transmission solutions for metal shredders**

As industry leaders in electromechanical power transmission products, the companies of Altra Industrial Motion have been helping metal shredder equipment manufacturers and metal recycling companies worldwide achieve great success by increasing their efficiency while at the same time reducing their costs and downtime. Altra engineered power transmission products are installed in a wide array of shredder applications including primary shredders, feeding apron conveyors, dust conveyors and magnetic material separator conveyors.



Altra companies provide a comprehensive offering of couplings, U-joints, gear motors, speed reducers, shaft locking devices and torque-limiting devices to meet the specific needs of the metal shredder industry. Altra products are designed to withstand harsh metal shredder environments including dirt, dust and high temperatures, while providing exceptional personnel safety and equipment protection.

The companies of Altra Industrial Motion offer advanced technologies together with unparalleled engineering capability. Our experienced shredder application engineers analyze every application challenge in order to provide the optimal power transmission solutions for our customers.

To help shredder operators control inventories, Altra teams work hard to achieve short lead times, on-time deliveries and fast-turnaround rebuild services. Our products are designed to reduce downtime by meeting the requirements for long service intervals, easy maintenance and quick interchanges.

For more information about application-specific power transmission solutions for metal shredders from Altra Industrial Motion, including case studies and literature, visit:

**[www.AltraMetalShredders.com](http://www.AltraMetalShredders.com)**





**Altra offers full drivetrain solutions to keep metal shredders running efficiently... worldwide.**



### ***Couplings and Shaft Locking Devices***

Altra U-joints feature swing diameters up to 1200 mm provide exceptional endurance and reduced vibration on all types of metal shredders. Durable shaft locking devices and gear couplings are used on a variety of metal recycling equipment. Altra elastomeric couplings are often found on conveyor drivetrain applications due to their superior environmental performance.

**ALTRA COUPLINGS: Ameridrives Couplings • Ameridrives Power Transmission • TB Wood's • Bibby Turboflex**



### ***Gear Motors and Enclosed Gearing***

As the leading innovator of worm and helical gear technologies, Altra continues to improve product performance by developing features, designs and custom-engineered solutions to meet the demands of the metal recycling market. Altra offers a full range of rugged-duty geared motor solutions and custom-designed speed reducers for various drive applications throughout metal recycling operations.

**Bauer Gear Motor • Delroyd Worm Gear • Nuttall Gear**



### ***Overload Devices***

Bibby Torque Limiters, with up to 95% torque setting accuracy, are found in many metal recycling applications including shredders and feeder conveyors. Shear pin, shear groove and SafeSet models from Ameridrives Power Transmission are also available. All devices are preset to release at a specific torque value to prevent drive damage and downtime.

**Ameridrives Power Transmission • Ameridrives Couplings • Bibby Turboflex/ Brunel Corporation**



### ***Backstops***

Marland and Formsprag backstops are utilized to prevent backward rotation during power-off situations on inclined feeder, transport, and separator conveyors. Formsprag and Marland offer a wide range of backstopping designs including internal to the gear reducer models, externally mounted high speed models, and externally mounted low speed models.

**Marland Clutch • Formsprag Clutch**



### ***Belted Drives***

Rugged TB Wood's sheaves and V-belts are utilized on certain types of large metal shredder designs as well as conveyors. TB Wood's provides unmatched made-to-order capabilities accommodating special drive requirements. Ductile iron for high impact or high speed applications or flywheels for extra inertia on whole car shredders, our engineering staff has the experience to design the solution for any shredder application.

**TB Wood's**

# Auto Shredders

## Auto (ELV) Shredders

Ameridrives Power Transmission provides state-of-the-art universal joint technologies including innovative torque overload designs and integrated shaft locking devices used on rotary metal shredder applications. Ameridrives locking devices are often used on these heavy-duty driveshafts that connect the electric drive motor(s) to the main shredder rotor (drum). Nuttall Gear heavy duty speed parallel shaft speed reducers are also used to drive the shredders.

**Ameridrives Power Transmission** Americardan 5000 & 3000 series universal joints

**Ameridrives Couplings** Amerigear® couplings

**Ameridrives Couplings** Ameriloc® shaft locking devices

**Ameridrives Couplings / Ameridrives Power Transmission**  
Overload devices

**Bibby Turboflex / Brunel Corporation**  
Modular torque limiters

**Nuttall Gear** Parallel shaft speed reducers

**TB Wood's** Standard V-belt and synchronous drives, high capacity premium V-belt and high capacity QT Power Chain II synchronous drives, made-to-order drives & components per customer specification

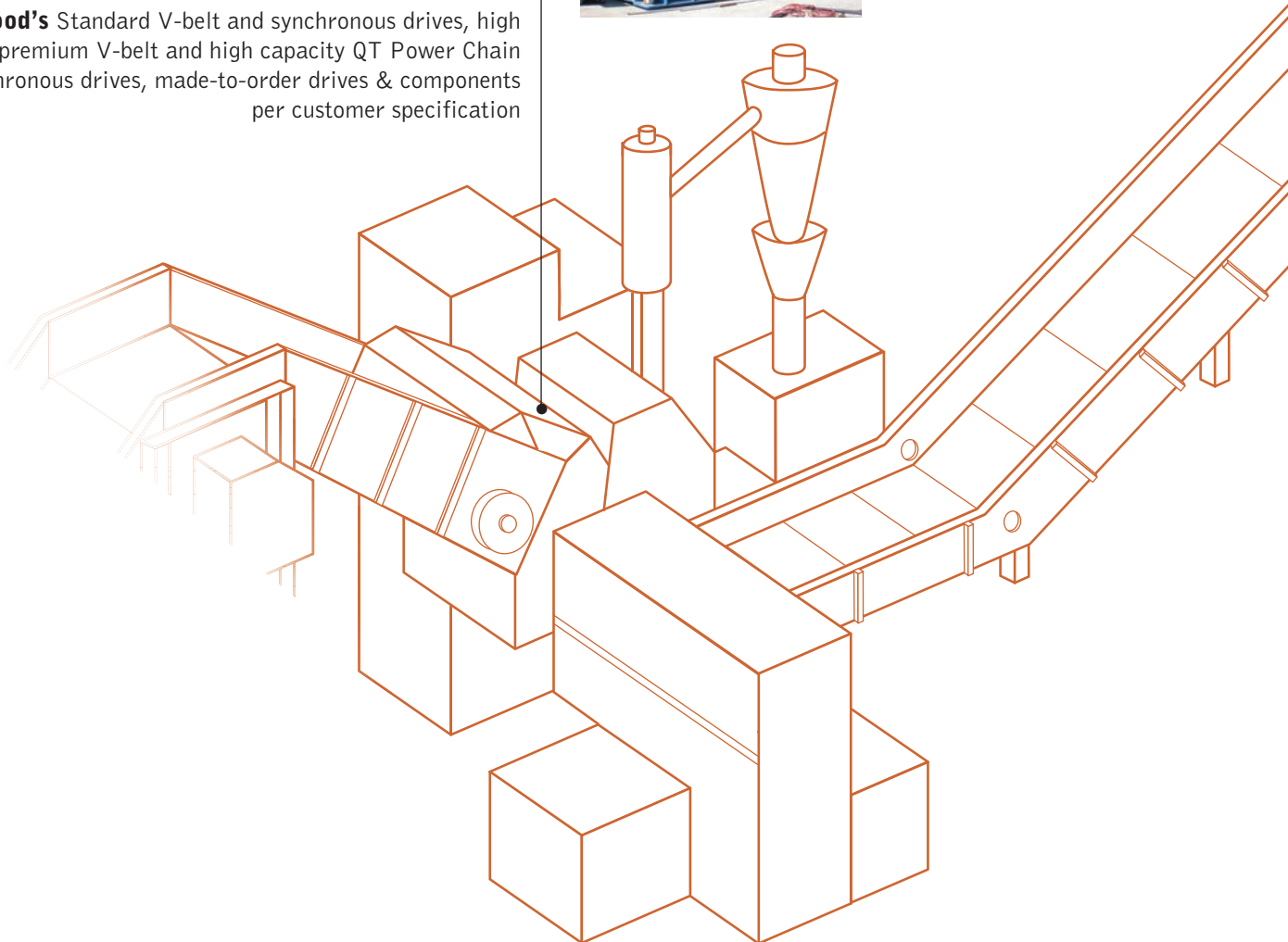

## Americardan 5000 & 3000 Series Universal Joints are ideal for use in metal shredder applications

Ameridrives Power Transmission (APT) engineers have worked closely with many shredder manufacturers (OEM's) and recycling yards in the design, installation, and repair of heavy-duty driveshaft assemblies.

Typical application of APT heavy-duty driveshaft assemblies is a direct connection between an electric prime mover and shredder rotor. Electric motor power ranges are 2,000-10,000 horsepower (1490 – 7460 kW) operating at 500 to 650 rpm. Heavy-duty driveshafts are excellent choices for shredder applications for a number of reasons:

- Driveshafts allow for larger misalignment angles than other types of couplings
- Axial travel section compensates for movement of the shredder rotor and variations within the installation
- Units provide high torque capacity versus rotational diameter
- Universal driveshafts are easier to maintain
- Units provide long service life 7-10 years (when properly selected)

### Additional Advantages

- Domestic manufacture and design
- Proven designs and decades of experience in heavy steel rolling and shredding applications
- High torque capacity
- High operating angle capacity
- One piece yoke reduces the number of extra bolted connections and serrations to wear and maintain
- Heat treated alloy steel components
- Nitrided splined travel sections available upon request for improved durability
- Ideal loading across entire bearing surface as a result of FEA analysis insuring balanced deflection between the yoke and cross
- Modular bearing assemblies with inner races allows for repeated reuse of the cross body saving on repair costs (sizes 3440 and greater)
- Factory repair facility

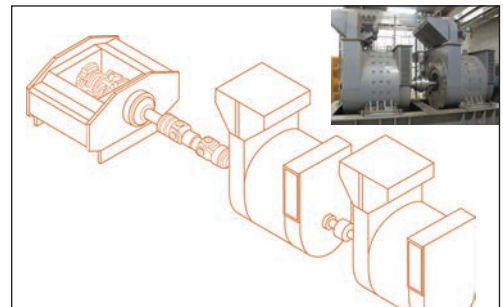
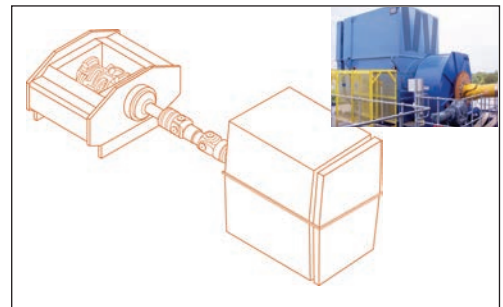
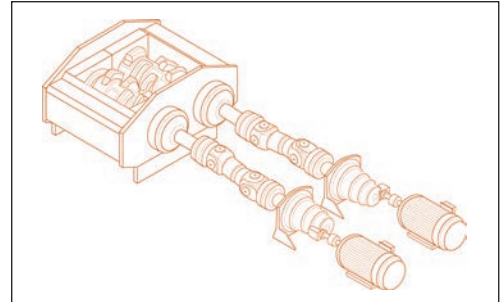

Americardan 5000 & 3000 series universal joints are designed for any shredder drive configuration including dual rotor/motor, single rotor/motor and single rotor with twin inline motors.

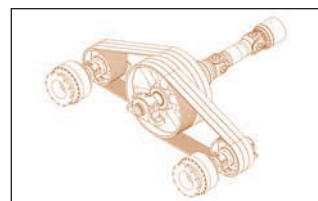

Complete Altra drivetrains are also available for use with natural gas engines.

# Scrap Shredders

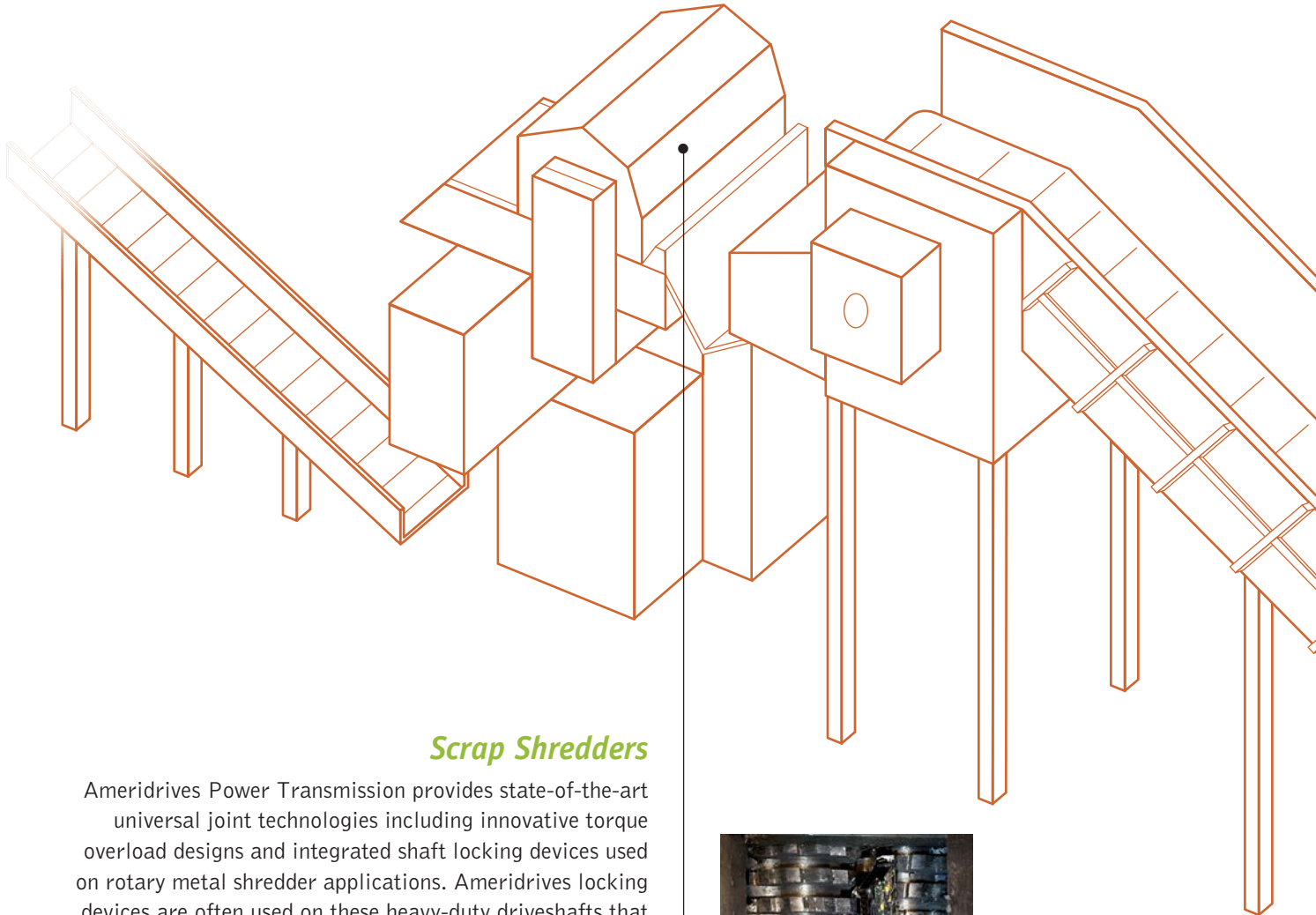

## Scrap Shredders

Ameridrives Power Transmission provides state-of-the-art universal joint technologies including innovative torque overload designs and integrated shaft locking devices used on rotary metal shredder applications. Ameridrives locking devices are often used on these heavy-duty driveshafts that connect the electric drive motor(s) to the main shredder rotor (drum). Nuttall Gear heavy duty speed parallel shaft speed reducers are also used to drive the shredders.



**Ameridrives Power Transmission** Americardan 5000 & 3000 series universal joints

**Ameridrives Couplings** Amerigear® couplings

**Ameridrives Couplings / Ameridrives Power Transmission**  
Overload devices

**Bibby Turboflex / Brunel Corporation**  
Modular torque limiters

**Ameridrives Couplings** Ameriloc® shaft locking devices

**Nuttall Gear** Parallel shaft helical speed reducers

## Feeding Conveyors

Formsprag and Marland backstops prevent reverse rotation on incline conveyors that feed scrap material into the shredder. Heavy duty Nuttall reducers, Bauer geared motors and Ameridrives Couplings are often utilized on conveyor drivetrains.

**Marland Clutch** BCMA backstops

**Formsprag Clutch** Backstops

**Nuttall Gear** Helical speed reducers

**Ameridrives Couplings** Amerigear® couplings

**Bibby Turboflex / Brunel Corporation** Modular torque limiters

**Bauer Gear Motor** BK series bevel gear motors

**Ameridrives** Ameriloc® shaft locking devices

**TB Wood's** Standard synchronous drives and high capacity QT Power Chain II synchronous drives

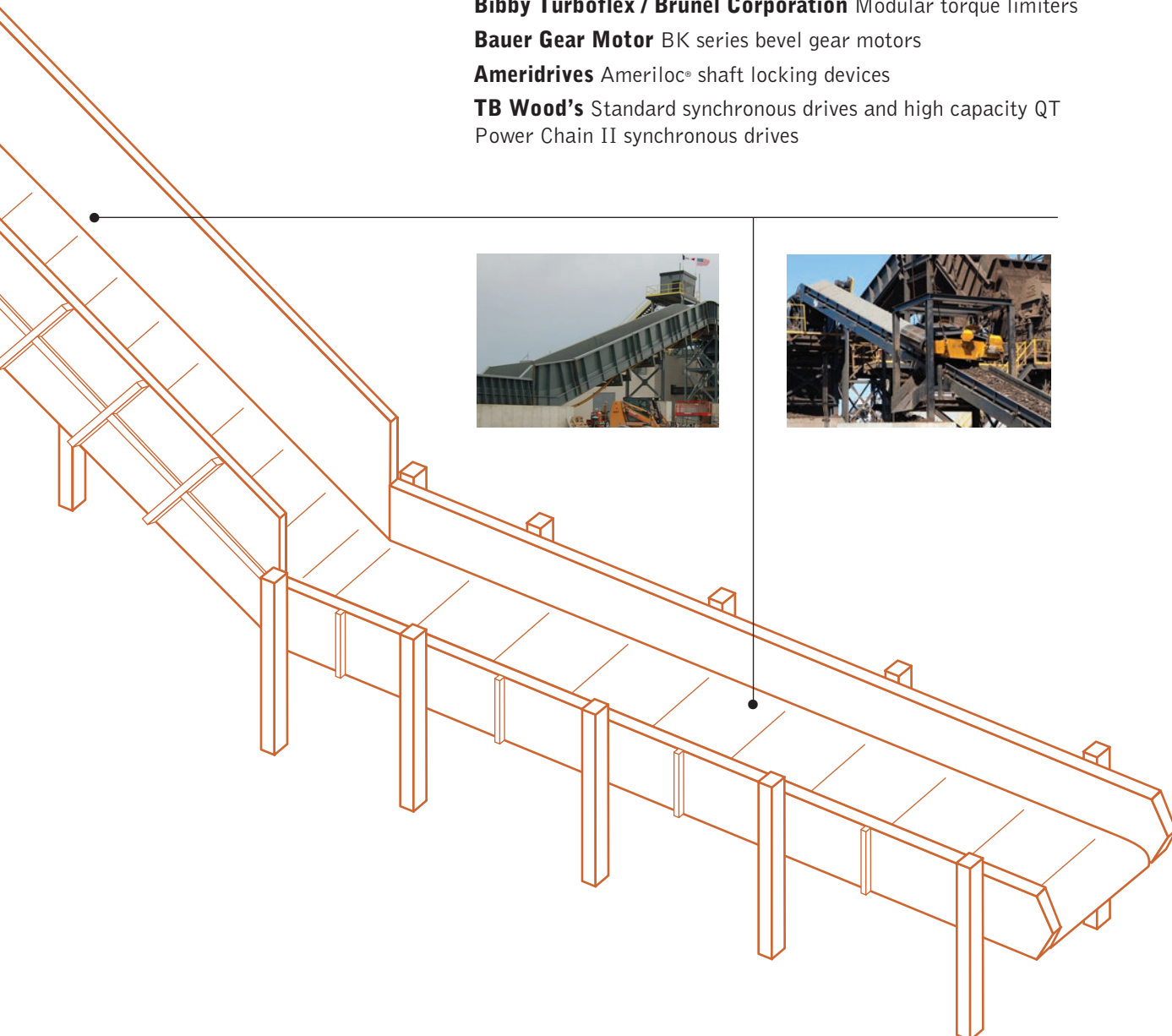



# Transport and Separator Conveyors

## Transport Conveyors

Marland and Formsprag backstops prevent reverse rotation on incline conveyors that feed scrap material into the shredder. Heavy duty Nuttall and Delroyd speed reducers, Bauer gear motors and Ameridrives Couplings are often utilized on conveyor drivetrains.

**Nuttall Gear** Helical speed reducers

**Delroyd Worm Gear** Speed reducers

**Bauer Gear Motor** BK series bevel gear motors

**Marland Clutch** Backstops

**Formsprag Clutch** Backstops

**Ameridrives Couplings** Amerigear® couplings

**TB Wood's** Standard synchronous drives and high capacity QT Power Chain II synchronous drives

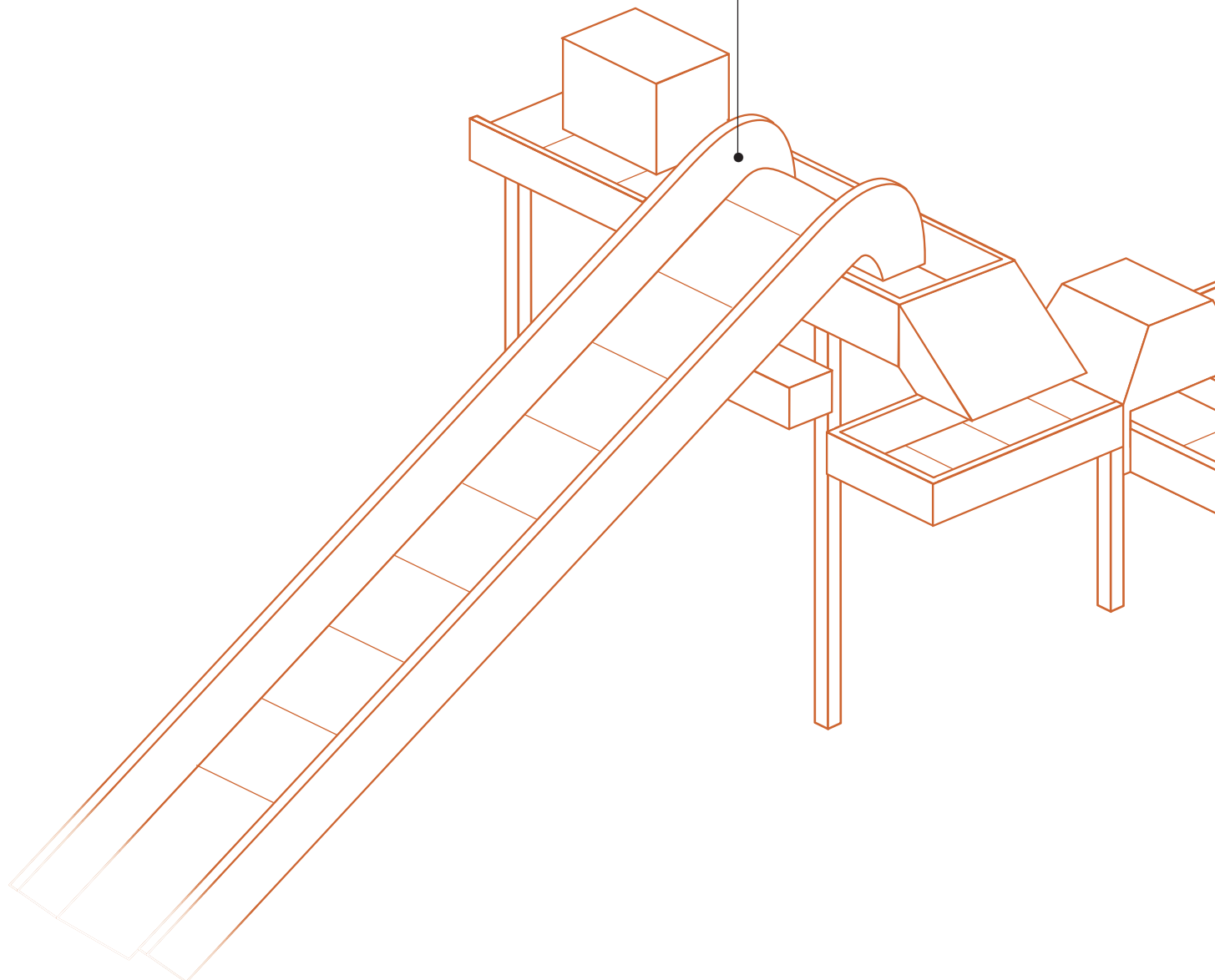



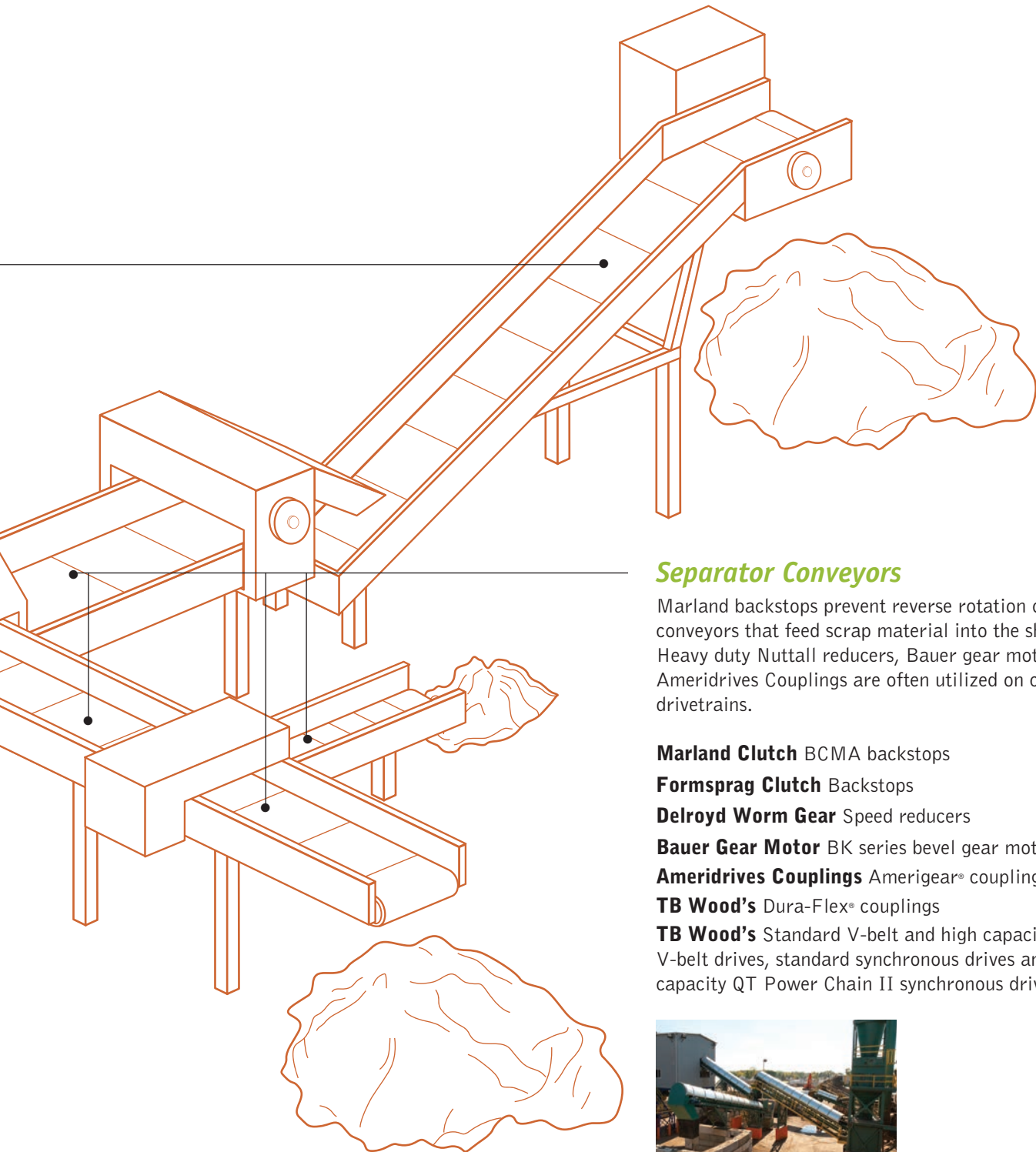

### Separator Conveyors

Marland backstops prevent reverse rotation on incline conveyors that feed scrap material into the shredder. Heavy duty Nuttall reducers, Bauer gear motors and Ameridrives Couplings are often utilized on conveyor drivetrains.

**Marland Clutch** BCMA backstops

**Formsprag Clutch** Backstops

**Delroyd Worm Gear** Speed reducers

**Bauer Gear Motor** BK series bevel gear motors

**Ameridrives Couplings** Amerigear® couplings

**TB Wood's** Dura-Flex® couplings

**TB Wood's** Standard V-belt and high capacity premium V-belt drives, standard synchronous drives and high capacity QT Power Chain II synchronous drives



## Universal Joints

### Ameridrives Power Transmission Americardan 5000 & 3000 Series

Designed for operation at high misalignment angles up to 15°. Bearing and seal design resists lubrication loss and contamination. Ideal for use in severe atmospheric conditions. Superior materials and tight tolerances have proven to reduce vibration levels.

**5000 Series** are high torque designs ideal for applications with diameter restrictions. Catalog sizes range from 225 mm to 860 mm swing diameters and peak torque capacities up to 5647 kNm. Higher torque, custom designs are available in excess of 1200 mm swing diameter.

**3000 Series** are rated for high misalignment angles and are available in catalog sizes from 55 mm to 860 mm swing diameters and peak torque capacities up to 3153 kNm. Higher torque, custom designs are available in excess of 1000 mm swing diameter. Sizes 3440 and larger incorporate a unique inner race design within the bearing package to reduce routine repair costs by approximately 50%.

- One-piece yoke delivers a high degree of strength with minimum distortion under load.
- One-piece bearing housing reduces the number of bolted connections improving reliability.
- Zero clearance bearing housing retention provides extended service life.
- Multiple rows of precision roller bearings reduce bearing end loading extending service life.

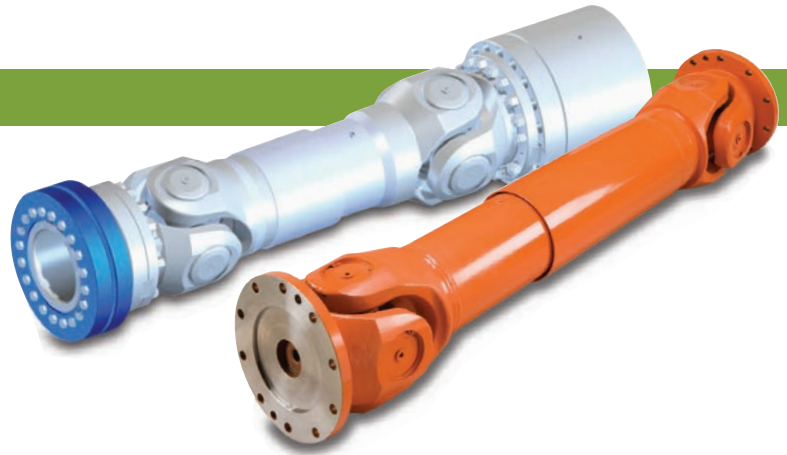

### Universal Joint Selection

Selection of the heavy-duty cardan shaft is done with consideration of multiple application specifics and customer requirements. B10 life is defined as the minimum bearing life expectancy for 90% probability of survival. Precision machining and superior grades of steel typically extend the average actual operating life of the bearings by five times the calculated B10 life.

The second key part in proper shaft selection is assuring that the shaft does not see a sudden failure from normal torque loads and/or excessive shock loads. A review of the normal torque expected, adjusted by the proper service factors, assures shaft integrity through the bearing lifespan and beyond.

One final aspect of selection is the potential for torsional vibration as a result of system harmonics. System data from the application should be analyzed to assure that the system's natural frequency does not coincide with the rotational speed of the universal joint.

### *Fast product availability combined with comprehensive engineering support*

APT components are manufactured in several locations around the world which allows us to offer quick service on complete assemblies and spare parts. APT application engineers can work directly with your engineering and design personnel to develop a final design that can be supplied usually within standard lead times. When retrofitting or replacement of existing drivelines is required, complete design control allows APT to offer other major manufacturers connection types to insure interchangeability. Repair work is also made easier as factory parts are available globally.

## Americardan Universal Joint Sizes

(ALL DIMENSIONS IN MM UNLESS NOTED)

### DC Motor

Power*		HP	1500	2000	2500	3000		3500		4000		5000	6000
Ameridrives Size*			U3315	U3315	U3350	U3350	U3390	U5350	U3390	U5390	U3440	U3440	U3440
Tdw	Nm		74,800	74,800	110,700	110,700	158,200	190,000	158,200	246,000	269,000	269,000	269,000
Tk	Nm		152,300	152,300	233,600	233,600	310,700	374,000	310,700	486,000	553,000	553,000	553,000
Standard Length			N/A	N/A	N/A	96"	96"	96"	96"	96"	96"	96"	96"
Flange	A	mm	350	350	390	390	435	390	435	435	435	435	435
Type			Friction	Friction	Friction	Friction	Friction	Friction	Friction	Key	Key	Key	Key
Slip	S	mm	+/-70	+/-70	+/-75	+/-85	+/-95	+/-85	+/-95	+/-95	+/-95	+/-95	+/-95
Swing	C	mm	315	315	350	350	390	350	390	390	440	440	440
Pilot	B	mm	220	220	250	250	280	250	280	190	190	190	190
Flange Thickness	G	mm	25	25	32	32	40	32	40	42	42	42	42
Bolt Circle	DBC	mm	310	310	345	345	385	345	385	385	385	385	385
Bolt Holes	H	mm	22	22	24	24	27	24	27	28	28	28	28
# of Bolts	I	mm	10	10	10	10	10	10	10	16	16	16	16
Key Width	X	mm	N/A	N/A	N/A	N/A	N/A	N/A	N/A	80	80	80	80

### AC Motor

Power*		HP	3000		3500		4000		5000	6000	7000	8000	10000
Ameridrives Size*			U5350	U3390	U5390	U3440	U5390	U3440	U3490	U3490	U3550	U3550	U5550
Tdw	Nm		190,000	158,200	246,000	269,000	246,000	269,000	358,000	358,000	594,000	594,000	747,000
Tk	Nm		374,000	310,700	486,000	553,000	486,000	553,000	811,000	811,000	1,243,000	1,243,000	1,474,000
Standard Length			96"	96"	96"	96"	96"	96"	96"	96"	96"	96"	96"
Flange	A	mm	390	435	435	435	435	435	480	480	550	550	550
Type			Friction	Friction	Key	Key	Key	Key	Key	Key	Key/Hirth	Key/Hirth	Key/Hirth
Slip	S	mm	+/-85	+/-95	+/-95	+/-95	+/-95	+/-95	+/-95	+/-95	+/-95	+/-95	+/-95
Swing	C	mm	350	390	390	440	390	440	490	490	550	550	550
Pilot	B	mm	250	280	190	190	190	190	205	205	250	250	250
Flange Thickness	G	mm	32	40	42	42	42	42	47	47	50	51	51
Bolt Circle	DBC	mm	345	385	385	385	385	385	425	425	492	492	492
Bolt Holes	H	mm	24	27	28	28	28	28	31	31	31	31	31
# of Bolts	I	mm	10	10	16	16	16	16	16	16	16	16	16
Key Width	X	mm	N/A	N/A	80	80	80	80	90	90	100	100	100

\*Values are guidelines only. Selection is based on normal torque @ 500 RPM. Please contact an Ameridrives Power Transmission application engineer to confirm driveshaft size is appropriate for your specific application.

Tdw = Normal rating for fully reversing torque

Tk = Functional limit torque

Tow = (1.5 x Tdwg) Pulsating one way torque

## Universal Joint Rebuild Service



***The difference is not just cosmetic.***



### **Remanufactured Universal Joints Look like new, warrantied like new.**

- *Rebuilt universal joints expedited in 24-48 hours*
- *Complete universal joints in as little as 1-2 weeks (Standard bearing assembly or cross and bearing replacement)*

Ameridrives Power Transmission Rebuild Service Department can refurbish your universal joints. We take your worn, scaled, seized, scored, or rough running U-joints and make them like new... for substantially less than the replacement cost.

As a major manufacturer of universal joints, we have the people, facilities, and experience to rebuild and replace all components as needed. The same standards of excellence that exist in the manufacture of original equipment U-joints are closely adhered to in the overhaul procedure of every rebuilt universal joint.

The Rebuild Service Department will inspect, refurbish or replace your universal joint to original specifications with a new warranty.



### ***Consider these advantages:***

The Rebuild Service Department will perform the following procedures to restore your universal joint to original specifications with a new warranty.

- Price – A savings of approximately 30% (compared to list price for a new unit)
- Speed – Universal joints are received, inspected and rebuilt in the shortest possible time frame
- Warranty – 1 Year on labor and materials, same as new universal joints
- Emergency Breakdown Program – All products that are expedited into the Ameridrives Power Transmission plant are processed immediately and, in many cases, are able to be rebuilt within a 24-hour period.

**Contact your Altra representative for details on our cost-saving program.**



## Couplings



### Ameridrives Couplings Amerigear Gear Couplings

Fully-crowned gear teeth provide operational benefits including maximum load-carrying capacity with minimum size, maximum reliability and long life.

- Both "O" ring and metal seal models are available
- Strong, rigid floating sleeve
- Precision-machined identical hubs
- Positive dust-tight seals
- Conforms to AGMA standards
- 3/4° to 1-1/2° operating angle



### TB Wood's Dura-Flex® Couplings

Dura-Flex couplings "split-in-half" element design allows for easy element installation/replacement without moving connected equipment or disturbing the shaft connection. Spacer design can accommodate a large range of shaft spacing with few parts.

- Easy to assemble/replace
- High misalignment ratings
- No maintenance/lubrication
- Part-for-part interchangeable with industry standard design
- In-stock versatile spacer design can accommodate many configurations with few parts
- UV radiation resistant

## Locking Devices



### Ameridrives Couplings Ameriloc® Locking Devices

Ameridrives Ameriloc external locking devices are custom-engineered, manufactured, and tested to precise tolerances to meet specific customer requirements. All units are highly engineered to provide years of trouble-free service with features including:

- Quality materials and manufacturing processes ensure high reliability
- Reduced shaft stress
- Designed for heavy-duty, industrial applications
- High contact pressure provides greater torque
- Easy installation and removal using standard tools
- Elimination of keyways and splines allow for unlimited shaft positioning
- Tight contact prevents contamination in high dust and moisture environments
- All units are pre-assembled, ready to install
- Torque range from 13 to 2,227,434 ft.lbs. (18 to 3,020,000 Nm)
- Outer diameters from .55 to 24.41 in. (14 to 1,000 mm)
- Shaft diameters from .39 to 20.49 in. (10 to 680 mm)

## Backstops



### Marland Clutch BC Model Backstops

Low-speed holdback for conveyor head shaft mounting. Provides positive protection against reverse torque runaways of inclined conveyors and elevators.

- Long service life
- Taconite seals
- Removable torque arm
- Superior roller design
- Bore ranges up to 600 mm
- Torque ratings up to 2,100,000 lb.ft. (2847 kNm)

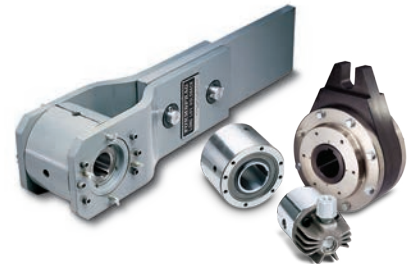

### Formsprag Clutch Backstops

Formsprag offers a wide range of backstopping designs including internal to the gear reducer models FS-50 & RSCI: externally mounted high speed models FSO, FHB, FRB & HSB and externally mounted low speed models LLH.

- Bore range 0.5 to 20.0 in. (12 to 500 mm)
- Torque ranges up to 700,000 lb. ft. (949 kNm)
- Centrifugal throwout design for low maintenance
- Widest range of models in the industry

# Product Solutions

## Overload Devices

Bibby Turboflex/Brunel Corporation, Ameridrives Power Transmission and Ameridrives Couplings overload devices are preset to release at a specified torque value in order to protect drive systems from expensive damage and lost production. Units have been successfully utilized in a wide variety of different industries where, subject to space availability, the release torque capacity is virtually unlimited. Altra overload devices can save you money – their initial cost is frequently more than covered by the saving in downtime... even on the first overload.



### Ameridrives Power Transmission Ameridrives Couplings Shear Pin Device

Units feature replaceable torque limiting shear pins. Pins are preset to desired torque limit. Pin count based on torque requirements.

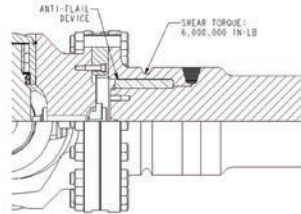

### Ameridrives Power Transmission Ameridrives Couplings Shear Groove Device

Device features a machined groove which is designed to shear at a pre-determined torque limit (based on drivetrain).

- Replaceable modular units available

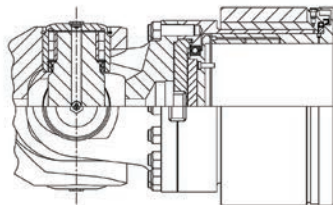

### Ameridrives Power Transmission Ameridrives Couplings SafeSet Device

SafeSet Torque-limiting Safety Coupling features a hollow steel sleeve which is expanded by oil under pressure producing a friction connection between a shaft and a hub. At overload the coupling instantaneously releases the oil pressure and interrupts the drive.

- Fast reset; no replacement parts required
- Fully adjustable release torque
- Selected release torque remains constant
- Back-lash free power transmission
- Compact, low weight design
- Low moment of inertia



### Bibby Turboflex/Brunel Corporation Torque Limiters

Torque limiters from Bibby Turboflex/Brunel Corporation provide economical overload protection on all types of shredders and feeder conveyors.

- Accurate release torque repeatability
- Simple, fast manual re-engagement, no replacement parts required
- Low-cost maintenance
- Versatile mounting capability

## Belted Drives



### TB Wood's Classical and Narrow V-Belt Sheaves

TB Wood's sheaves are constructed of fine grain, high tensile cast iron, and have been engineered to assure maximum performance over a long life span.

- Max safe operating speed, in RPM, is cast or stamped on all sheaves
- Convenient Sure-Grip QD type bushings are available
- All models are designed to the industry standards
- Standard and deep groove models available

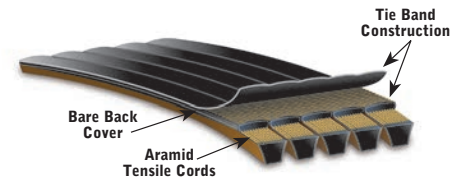

### TB Wood's Premium V-Belts

Premium belts have the highest power density of any V-belt, and stretch dramatically less than standard cross sections.

- Ideal for use on problem drives requiring high-impact strength and load-carrying power.
- "Clutching" non-rubber surfaced cover allows momentary slippage due to excessive overloads without burning belts up.
- KEVLAR\* or aramid tensile cords give extraordinary strength, durability and virtually zero stretch.
- Virtually zero stretch eliminates the need for constant belt re-tensioning.
- Chloroprene rubber compounds provide superb oil and heat resistance.
- Specially-treated extra tough cover withstands slip and shear forces at peak loads without generating excessive heat.

\* KEVLAR® is a registered trademark of Dupont™

## Gear Motors and Enclosed Gearing

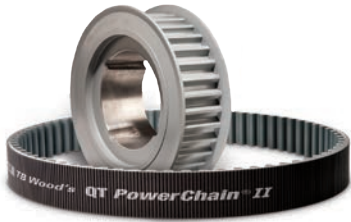

### TB Wood's QT Power Chain® II Belt Drive System

The QT Power Chain II Belt Drive System, when compared with standard roller chain, provides a powerful belt drive system with significantly reduced overall costs. The new sizes of belts and sprockets offer a compact drive with increased power ratings (up to 40% higher than its predecessor)

- Heavy duty belts
- Compact QD bushing design, ideal for conveyor applications
- 8mm Pitch, Horsepower from 1 to 140, Drive combinations: 66,600+, Speed Ratios: 336
- 14mm Pitch, Horsepower from 40 to 550, Drive combinations: 51,500+, Speed Ratios: 500



### TB Wood's MTO Capability (made-to-order)

TB Wood's made-to-order products are designed and manufactured to the precise application specifications to provide the most efficient and cost effective Shredder drive.

- High tensile strength materials
- Ductile iron (10,000 FPM)
- Dynamic balance capabilities for reduced vibration
- Molding and machine capability up to 108 inches in diameter
- Shredder sheaves often have additional material added to the rim ID for extra inertia to shock on heavy impact loads
- Our Engineering team can design drive components around Ameridrives Ameriloc locking devices for the ultimate Shredder drive



### Bauer Gear Motor BK Series Bevel Geared Motor

Power-dense, right-angle, bevel-gear motors ensure the highest efficiency especially when used with frequency inverters.

- The right angle gearbox with universal attachment possibilities
- Motor power from 0.03 kW to 75 kW
- 10 gearbox sizes for torques from 90 Nm to 18500 Nm
- High efficiency through 2-stage base design
- Enclosure IP 65 as standard



### Nuttall Gear Moduline® Concentric Shaft Speed Reducers

Moduline® concentric shaft reducers are available in engineered package assemblies for scrap conveyor and scrap chopper drives.

- Ratios up to 985.3:1
- 11 sizes with ratings up to 250,000 in. lbs. (28,246 Nm)
- Integral gear motor designs
- Scoop mounted gear motor designs
- Horizontal, vertical, ceiling or wall mounted



### Delroyd Worm Gear Speed Reducers

Delroyd worm gear reducers are used on shredders, feeding apron conveyors and separator conveyors.

- Ratio's from 5:1 up to 175,000:1
- Single, double, triple and helical worm
- Output torques up to 3,500,000 in. lbs.
- 2" thru 48" Center distance
- Standard cast iron or custom fabricated steel constructed
- Shafted or hollow bore designs
- Vertical or horizontal configurations



### Nuttall Gear TDS Parallel Shaft Speed Reducers

TDS Parallel shaft speed reducers provide high torque capability in order to drive shredders. Type TDS standard features include through hardened single helical gears, tapered roller bearings, large inspection plates, a positive splash system for lubrication, extra wide bearing spans and center bearing supports. All Type TDS units can be assembled with a variety of horizontal input and output shaft arrangements extending on either side of the speed reducer. Hollow output shafts are also available.

- Torque ratings up to 6,000,000 inch-pounds.
- Standard gear ratios up to 1500:1
- These units incorporate precision gearing (in single, double, triple, quadruple, and quintuple reductions)
- Enclosed in heavy-duty cast iron or fabricated steel housing

**Electromagnetic Clutches and Brakes**

**Warner Electric**

*Electromagnetic Clutches and Brakes*

New Hartford, CT - USA  
1-800-825-6544

*For application assistance:*  
1-800-825-9050

St Barthelemy d'Anjou, France  
+33 (0) 2 41 21 24 24

*Precision Electric Coils and Electromagnetic Clutches and Brakes*

Columbia City, IN - USA  
1-260-244-6183

**Matrix International**

*Electromagnetic Clutches and Brakes, Pressure Operated Clutches and Brakes*

Brechin, Scotland  
+44 (0) 1356 602000

New Hartford, CT - USA  
1-800-825-6544

**Inertia Dynamics**

*Spring Set Brakes; Power On and Wrap Spring Clutch/Brakes*

New Hartford, CT - USA  
1-800-800-6445

**Linear Products**

**Warner Linear**

*Linear Actuators*

Belvidere, IL - USA  
1-800-825-6544

*For application assistance:*  
1-800-825-9050

St Barthelemy d'Anjou, France  
+33 (0) 2 41 21 24 24

**Couplings**

**Ameridrives Couplings**

*Mill Spindles, Ameriflex, Ameridisc*

Erie, PA - USA  
1-814-480-5000

*Gear Couplings*

San Marcos, TX - USA  
1-800-458-0887

**Bibby Turboflex**

*Disc, Gear, Grid Couplings, Overload Clutches*

Dewsbury, England  
+44 (0) 1924 460801

Boksburg, South Africa  
+27 11 918 4270

**TB Wood's**

*Elastomeric Couplings*

Chambersburg, PA - USA  
1-888-829-6637 – Press #5

*For application assistance:*  
1-888-829-6637 – Press #7

*General Purpose Disc Couplings*

San Marcos, TX - USA  
1-888-449-9439

**Ameridrives Power Transmission**

*Universal Joints, Drive Shafts, Mill Gear Couplings*

Green Bay, WI - USA  
1-920-593-2444

**Huco Dynatork**

*Precision Couplings and Air Motors*

Hertford, England  
+44 (0) 1992 501900

Chambersburg, PA - USA  
1-888-829-6637

**Lamiflex Couplings**

*Flexible Couplings, Bearing Isolators, and Coupling Guards*

São Paulo, SP - Brasil  
+55-11-5679-6533

**Heavy Duty Clutches and Brakes**

**Wichita Clutch**

*Pneumatic Clutches and Brakes*

Wichita Falls, TX - USA  
1-800-964-3262

Bedford, England  
+44 (0) 1234 350311

**Twiflex Limited**

*Caliper Brakes and Thrusters*

Twickenham, England  
+44 (0) 20 8894 1161

**Industrial Clutch**

*Pneumatic and Oil Immersed Clutches and Brakes*

Waukesha, WI - USA  
1-262-547-3357

**Gearing**

**Boston Gear**

*Enclosed and Open Gearing, Electrical and Mechanical P.T. Components*

Charlotte, NC - USA  
1-800-825-6544

*For application assistance:*  
1-800-816-5608

**Bauer Gear Motor**

*Geared Motors*

Esslingen, Germany  
+49 (711) 3518 0

Somerset, NJ - USA  
1-732-469-8770

**Nuttall Gear and Delroyd Worm Gear**

*Worm Gear and Helical Speed Reducers*

Niagara Falls, NY - USA  
1-716-298-4100

**Overrunning Clutches**

**Formsprag Clutch**

*Overrunning Clutches and Holdbacks*

Warren, MI - USA  
1-800-348-0881 – Press #1

*For application assistance:*  
1-800-348-0881 – Press #2

**Marland Clutch**

*Roller Ramp and Sprag Type Overrunning Clutches and Backstops*

South Beloit, IL - USA  
1-800-216-3515

**Stieber Clutch**

*Overrunning Clutches and Holdbacks*

Heidelberg, Germany  
+49 (0) 6221 30 47 0

**Belted Drives and Sheaves**

**TB Wood's**

*Belted Drives*

Chambersburg, PA - USA  
1-888-829-6637 – Press #5

*For application assistance:*  
1-888-829-6637 – Press #7

**Engineered Bearing Assemblies**

**Kilian Manufacturing**

*Engineered Bearing Assemblies*

Syracuse, NY - USA  
1-315-432-0700

For information concerning our sales offices in Asia Pacific check our website [www.altramotion.com.cn](http://www.altramotion.com.cn)

