

ZKM Series

磁粉式電磁離合器 (中空軸型式) Magnetic Particle Clutch (Hallow-shaft type)

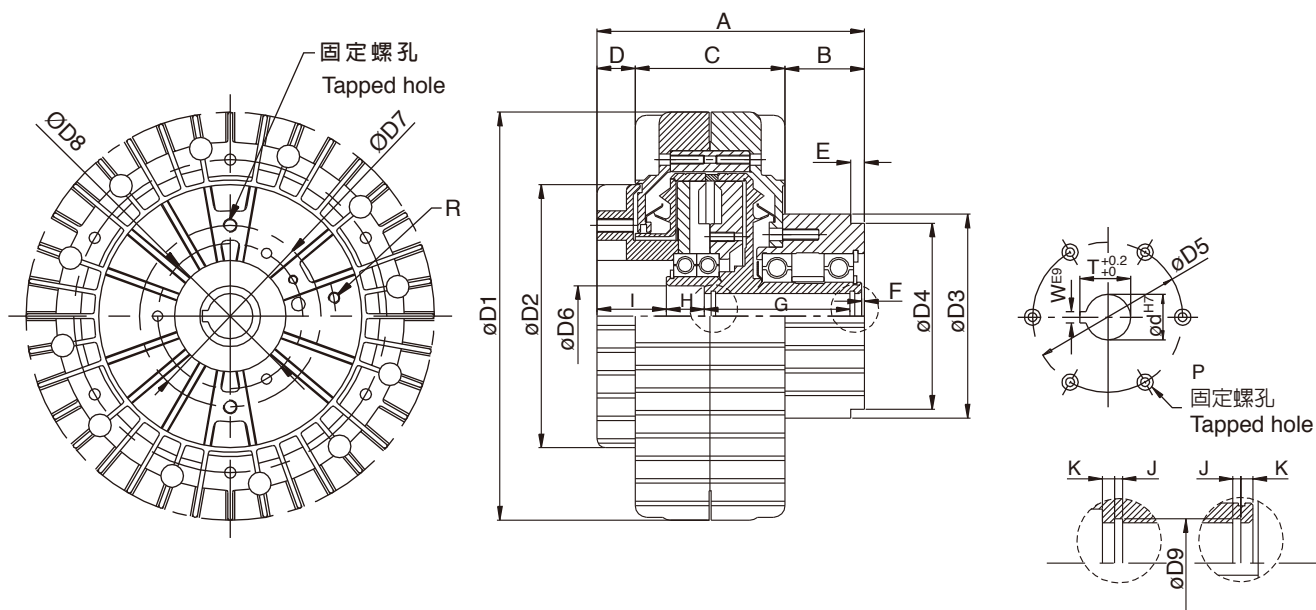

型號 MODEL		ZKM2S5AA	ZKM005AA	ZKM010AA
定格扭力 [kgm](Nm) Rated torque		2.5 (25)	5 (50)	10 (100)
容量 Capacity DC24V (75°C)	電流 (A) Current	1.1	1.4	2
	電力 (W) Power	26.4	33.6	48
	時定數 (S) Number of hours set	0.06	0.09	0.14
慣性矩J Moment of inertia (kgm ²)	入力軸 Input	1.2×10^{-2}	2.6×10^{-2}	7.0×10^{-2}
	出力軸 Output	2.3×10^{-3}	5.8×10^{-3}	1.5×10^{-2}
最高回轉速 (r/min) Max speed		1800		
外型尺寸 Exterior dimensions	A	119	141	166
	B	36	47	49
	C	66	74	100
	D	17	20	17
	E	20	30	30
	F	2	3	4
	G	69	103	122
	H	17	-	-
	I	31	35	40
	J	1.1	1.3	1.65
	K	4	5	5
	D1	180	220	275
	D2	114	140	176
	D3	-	-	130
	D4	90	110	125
	D5	80	95	110
	D6	27	-	-
	D7	80	95	110
	D8	64	78	95
	D9	21	31.4	37
d	20	30	35	
P	M6*12L	M8*15L	M10*20L	
R	M4*10L	M6*12L	M6*12L	
Q	M6*12L	M8*12L	M10*18L	
鍵槽 Keyway	W	5	7	10
	T	22.3	33.3	38.8