

ZKA Series

磁粉式小型電磁離合器 Micro Magnetic Particle Clutch

型號 MODEL	定格轉距 Rated torque [kgm](Nm)	容量 Capacity DC24V(75°C)			慣性矩 J Moment of inertia (kgcm ²)		重量 Weight (kg)	最高轉速 Maximum speed (r/min)
		電流 (A) Current	電力 (W) Power	時定數 (S) Number of hours set	入力側 Input side	出力側 Output side		
ZKAS05AA	0.05(0.5)	0.35	8.4	0.02	2.1×10^{-1}	1.7×10^{-2}	0.67	1800
ZKAS10AA	0.1(1.0)	0.47	11.3	0.03	3.46×10^{-1}	4.6×10^{-2}	0.88	
ZKAS20AA	0.2(2.0)	0.55	13	0.055	6.8×10^{-1}	1.03×10^{-1}	1.27	
ZKAS50AA	0.5(5.0)	0.8	19	0.055	1.85	4.0×10^{-1}	2.3	
ZKA001AA	1.0(10)	1.0	24	0.09	5.3	1.1	4.1	

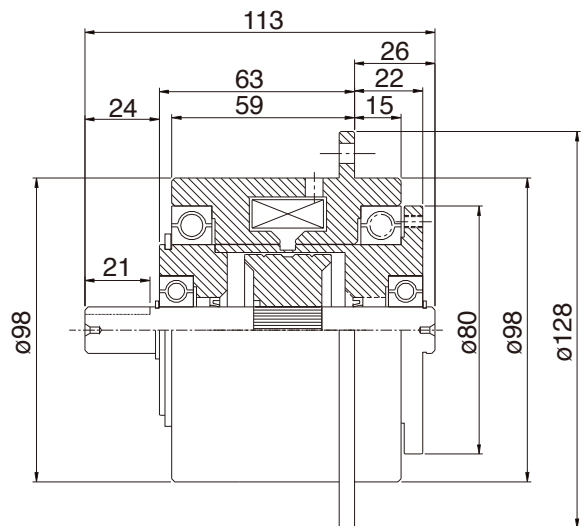
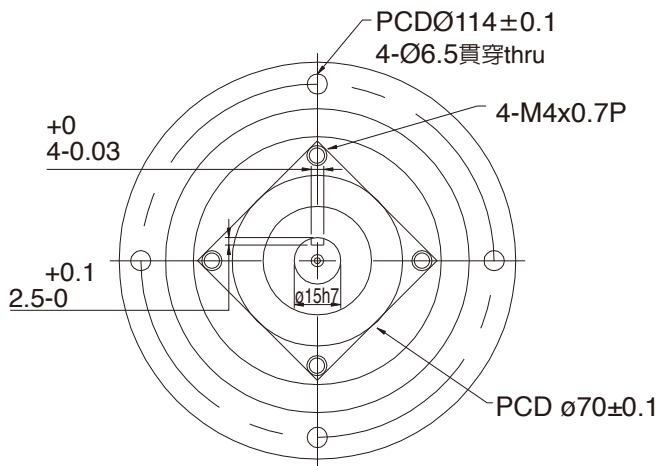
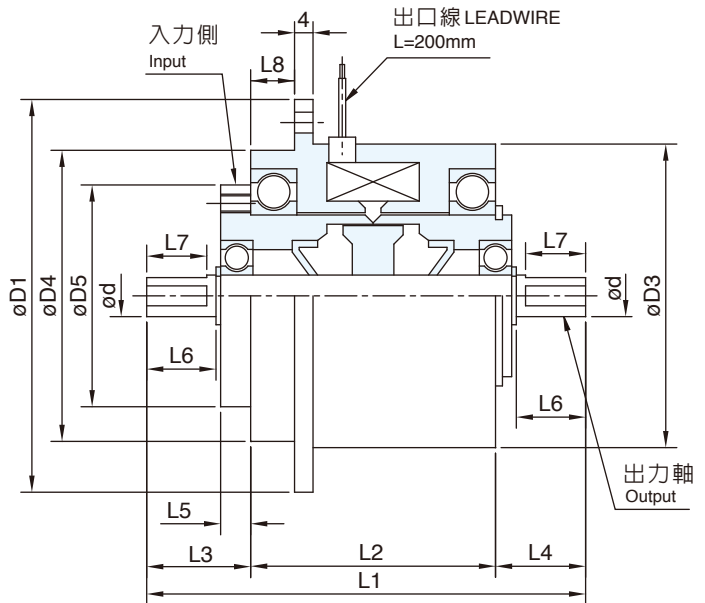
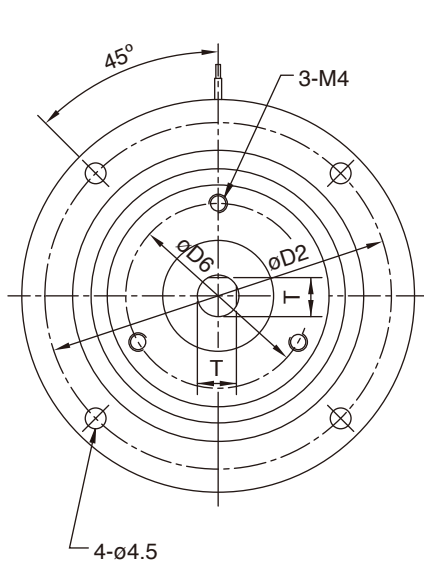

[ZKA001AA]

型號 MODEL	外型尺寸 Exterior dimensions															
	D1	D2	D3	D4(h7)	D5(g7)	D6	d(g6)	L1	L2	L3	L4	L5	L6	L7	L8	T
ZKAS05AA	70	60	50	48	40	30	5	77.2	47	16.6	13.6	5.5	10.5	9	8.5	4.5
ZKAS10AA	76	66	56	54	42	34	7	83	48.5	18.5	16	5.5	12	10	8.5	6.5
ZKAS20AA	85	75	65	63	48	40	9	95	53	22.5	19.5	6.5	15	13	9.5	8.5
ZKAS50AA	100	90	80	78	60	50	12	111	64	25	22	6	18	16	12	11.5