

# Basic Design Clutches/Brakes



 **Warner**<sup>®</sup>  
Electric

An Altra Industrial Motion Company

# Custom Design Clutches and Brakes

## Optimum Performance with Off-the-Shelf Components

### Clutches

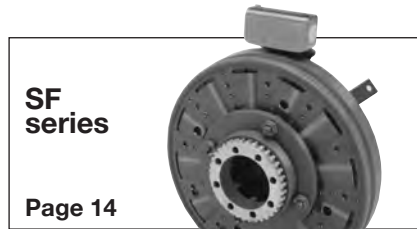

#### Stationary Field Design

™ Flange or bearing mounted styles  
™ The SF design eliminates collector rings and brush-holder. Ideal for adverse environmental conditions. Mounting tolerances are generally more critical than the PC design.



#### Primary Design

™ Current is carried through brushes and the collector ring to the rotating magnet. The PC design is less expensive than the SF design.

### Clutch Couplings

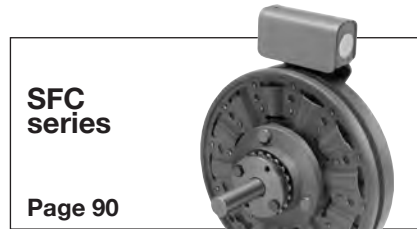

#### Stationary Field Design

™ The SFC Series clutch couplings employ the same basic components as the SF design except for a splined hub and adapter which serves as a coupling for in-line shaft applications.



#### Primary Design Coupling Units

™ The PCC Series clutch couplings employ the same basic components as the PC design except for a splined hub and adapter which serves as a coupling for in-line shaft applications.

### Brakes



#### Brake

™ The PB Series brakes consist of a magnet, armature and mounting hub in a very simple and extremely compact design.

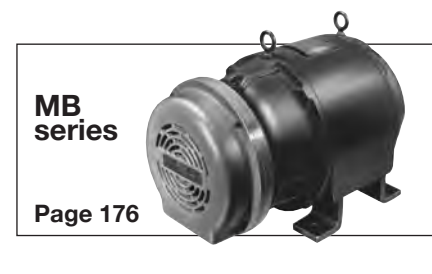

#### Motor Brake

™ MB motor brakes are composed of a PB Series brake mounted on a NEMA C-face adapter and cover assembly.

### Clutch/Brake Combinations



™ The PCBC clutch/brake coupling series combines a PCC clutch coupling with a PB brake.



#### Stationary Field Clutch/Brake Coupling

™ The SFPBC clutch/brake coupling series combines a SFC clutch coupling with a PB brake.



#### Primary style clutch/brake

™ The PCB Series clutch-brakes combine a PC clutch and a PB brake into one compact design.

## Custom design with off-the-shelf components

For maximum mounting versatility and design flexibility Custom Design products may be designed into the most demanding and space restrictive applications. They require additional engineering and assembly capability, but their lower initial cost and wider range of sizes makes them an ideal consideration for many applications. Like all Warner Electric packaged clutches and brakes, they never need adjustment, and they are built to the same standards of quality and performance.

## Wide Range of Sizes

Assembled around the basic components of an electric clutch-brake, magnet and armature, custom design products come in a tremendous range of sizes, torque ratings and configurations.

<b>Applying Clutches &amp; Brakes</b> .....	2-3
<b>Design Features</b> .....	4-5
<b>Selection</b> .....	6-11
<b>Mounting Examples &amp; Options</b> .....	12-13
<b>Custom Design Product Line</b>	
<b>Size 120</b>	
Clutches .....	14-17
Clutch Couplings .....	90-93
Brakes .....	146-147
<b>Size 170</b>	
Clutches .....	18-21
Clutch Couplings .....	94-97
Brakes .....	148-149
<b>Size 250</b>	
Clutches .....	22-25
Clutch Couplings .....	98-101
Brakes .....	150-151
<b>Size 400</b>	
Clutches .....	26-29
Clutch Couplings .....	102-105
Brakes .....	152-153
<b>Size 500</b>	
Clutches .....	30-31, 72-73
Clutch Couplings .....	106-109, 134-137
Brakes .....	154-157
Clutch Brake Couplings.....	208-211, 214-217
<b>Size 650</b>	
Clutches .....	32-35
Clutch Couplings .....	110-113
Brakes .....	158-159
Clutch Brake Couplings .....	212-213
<b>Size 825 &amp; 1000</b>	
Clutches .....	36-51, 74-81
Clutch Couplings .....	114-121, 138-141
Brakes .....	160-167
Clutch Brakes .....	188-195
Clutch Brake Couplings .....	218-221
Motor Brakes .....	176-183
<b>Size 1225</b>	
Clutches .....	52-59, 82-85
Clutch Couplings .....	122-125, 142-143
Brakes .....	168-171
Clutch Brakes .....	200-203
Clutch Brake Couplings .....	224-225
Motor Brakes .....	184-187
<b>Size 1225/1000</b>	
Clutch Brakes .....	196-199
Clutch Brake Couplings .....	222-223
<b>Size 1525</b>	
Clutches .....	60-71, 86-89
Clutch Couplings .....	126-133, 144-145
Brakes .....	172-175
<b>Size 1525/1225</b>	
Clutch Brakes .....	204-207
Clutch Brake Couplings .....	226-227
<b>Application Engineering</b> .....	229
<b>Ordering Information</b> .....	257
<b>Model Number / Drawing Number Index</b> .....	257
<b>Drawing Number / Model Number Index</b> .....	260
<b>Clutch and Brake Controls</b> .....	261

# Custom Design Clutches and Brakes

## Product Line

### Clutches

#### SF series

Page 14

#### Stationary Field Design

- " Flange or bearing mounted styles
- " The SF design eliminates collector rings and brush-holder. Ideal for adverse environmental conditions. Mounting tolerances are generally more critical than the PC design.

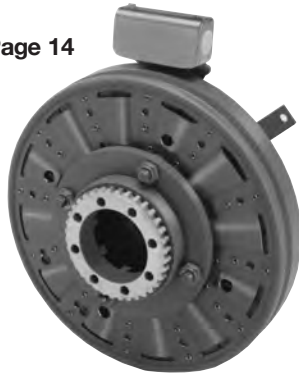

#### PC series

Page

72

#### Primary Design

- " Current is carried through brushes and the collector ring to the rotating magnet. The PC design is less expensive than the SF design.



#### Application

A clutch is used when the load is driven to a parallel shaft through sheaves, belts, sprockets or gears.

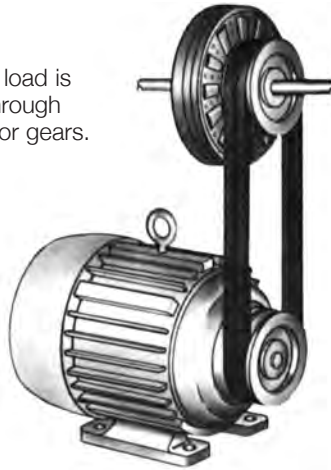
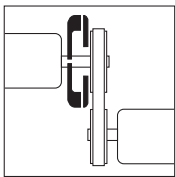

### Clutch Couplings

#### SFC series

Page 90

#### Stationary Field Design

- " The SFC Series clutch couplings employ the same basic components as the SF design except for a splined hub and adapter which serves as a coupling for in-line shaft applications.

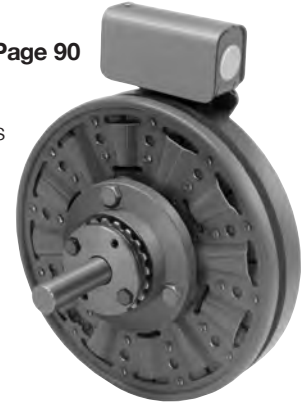

#### PCC series

Page 134

#### Primary Design Coupling Units

- " The PCC Series clutch couplings employ the same basic components as the PC design except for a splined hub and adapter which serves as a coupling for in-line shaft applications.



#### Application

A clutch coupling is used to couple two inline shafts.

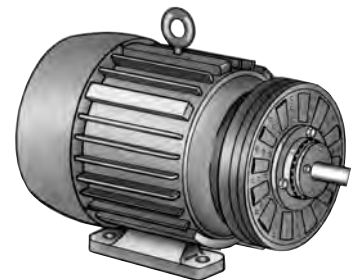
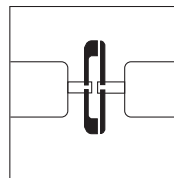

### Brakes

#### PB series

Page 146

#### Brake

" The PB Series brakes consist of a magnet, armature and mounting hub in a very simple and extremely compact design.

#### Application

A brake is used when a rotating load is to be stopped.

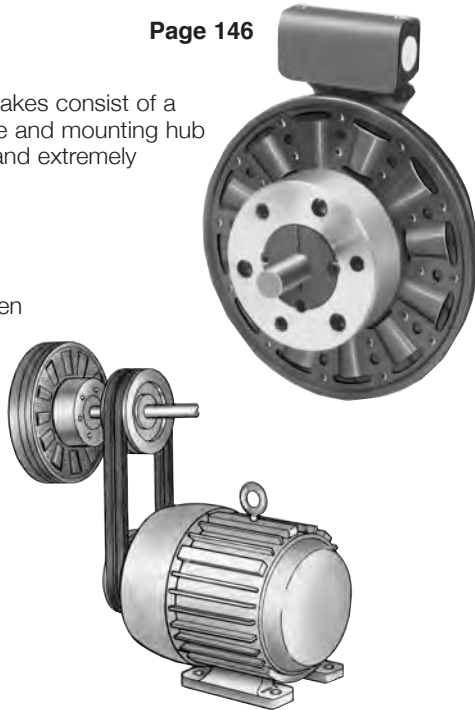
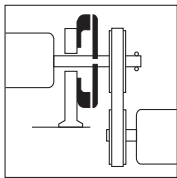

#### MB series

Page 176

#### Motor Brake

" MB motor brakes are composed of a PB Series brake mounted on a NEMA C-face adapter and cover assembly.

#### Application

A motor brake mounts directly on the end bell of a double shafted motor.

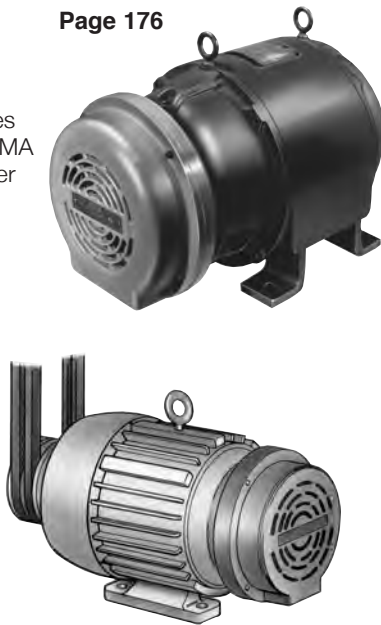
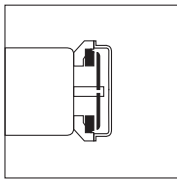

### Clutch/Brake Combinations

#### PCB series

Page 188

#### Primary style clutch/brake

" The PCB Series clutch-brakes combine a PC clutch and a PB brake into one compact design.

#### Application

A clutch-brake is used to combine the functions of a clutch and a brake in a compact assembly.

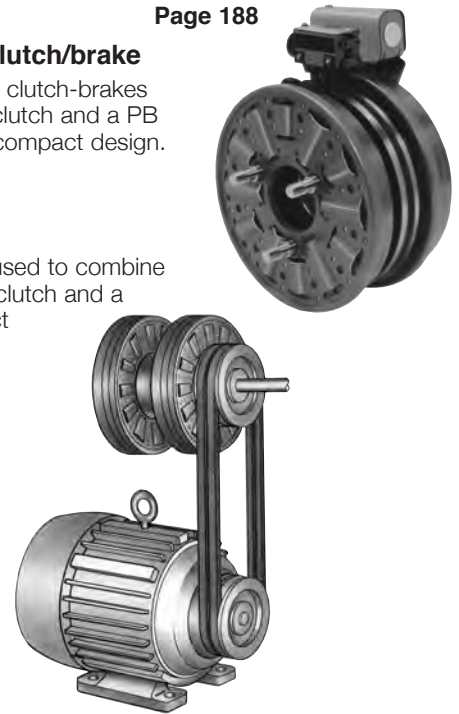
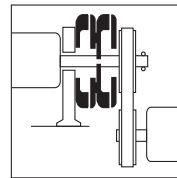

#### SFPBC series

Page 208

#### Stationary Field Clutch/Brake Coupling

" The SFPBC clutch/brake coupling series combines and SFC clutch coupling with a PB brake.

#### PCBC series

Page B-214

" The PCBC clutch/brake coupling series combines a PCC clutch coupling with a PB brake.

#### Application

A clutch-brake coupling is used to combine the functions of a clutch coupling and a brake.

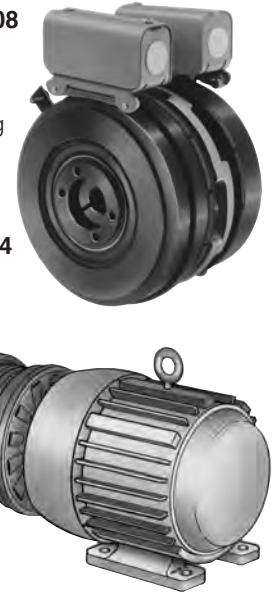
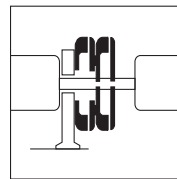

# Custom Design Clutches and Brakes

## Design Features

### Versatility and Flexibility

#### Armature

Fluted and segmented. Designed as a cooling device to dissipate maximum heat and increase life.

#### Bushings

Standard industry bushings are used in all the larger sizes to meet your shaft size requirement. Several bore sizes are available as standard in each of the smaller models.

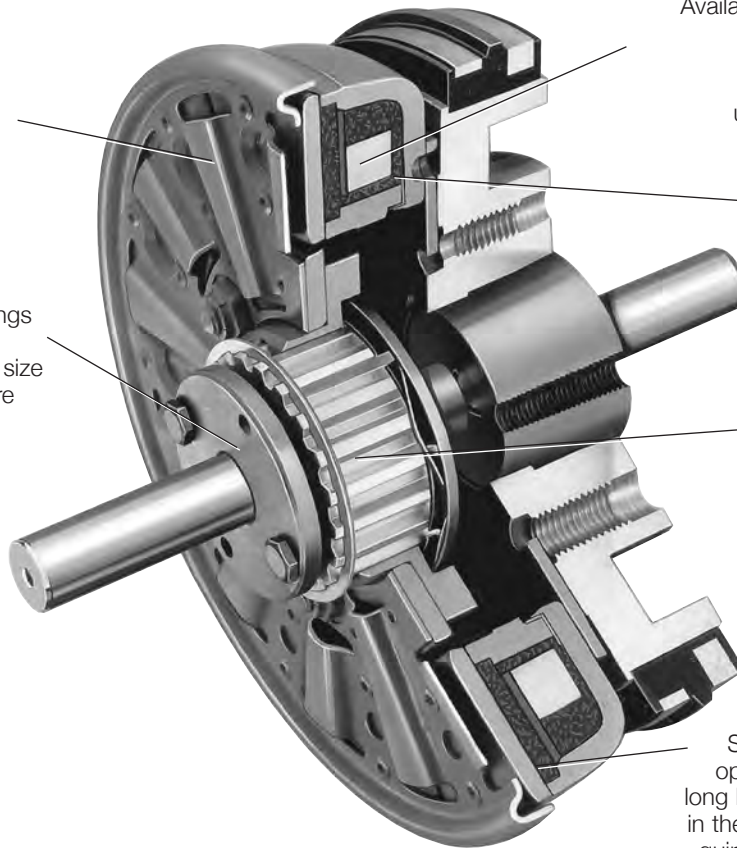

#### Coil

Available in various voltages for each model. Warner Electric controls (see controls section) provide optimum performance and controllability. All Warner Electric units are either UL listed or recognized. All are CSA certified.

#### Magnet or Field

Brake magnet mounts to any machine member. Warner Electric clutches are available in flange mount or bearing mount designs.

#### Armature Drives

Heavy duty spline drive absorbs shock. Rugged, long life materials used in outer and inner spline members. Pin drive design available for normal, lighter duty applications. Anti-backlash armatures available for sizes 170, 250, and 400.

#### Friction Material

Standard friction material represents the optimum in high torque performance and long life. Long wearing LK facing is available in the larger models to meet application requirements where exceedingly long life is a critical design factor.

Custom design brakes and clutches are user assembled from standard components for optimum performance in the smallest possible package size.

- “ Easily adaptable to any mounting requirement
- “ Low initial cost
- “ Wide range of models and options
- “ 10 sizes from 1-1/4" to 15-1/4" diameter
- “ 45 models of clutches, brakes and motor brakes
- “ Torque range: 5 lb.in. to 1350 lb. ft.
- “ Horsepower capability to 100 HP

#### Wide range of sizes

Assembled around the basic components of an electric clutch-brake, magnet and armature. Custom design products come in a tremendous range of sizes, torque ratings and configurations.

#### LK friction material

Warner Electric offers a special low coefficient (LK) friction material for many standard clutches and brakes. Since two friction materials are available, a comparison of LK to standard is in order.

Since LK has a lower coefficient of friction, lower torque capability results. With LK facing, static torque capacity is only about 60% of catalog rating for any given size. So if a specific size clutch or brake is chosen for its rated torque capacity and LK facings are substituted for standard, a larger size unit will be needed to provide the same torque.

If lower torque ratings can be considered a disadvantage, what are the advantages of LK material? The first is longer life. An ideal situation for LK use is a constant slip application which requires a large unit for high heat dissipation. Another feature of LK is "softer" pickup. Since more slippage will occur, engagement time is increased and shock is reduced. LK material will

also reduce engagement noise, so it can be successfully employed where high noise levels are a problem. It is the standard facing in all tension brakes and motor brake magnets.

For more information on LK facing, see page 232.

## Design Features

### Two clutch designs

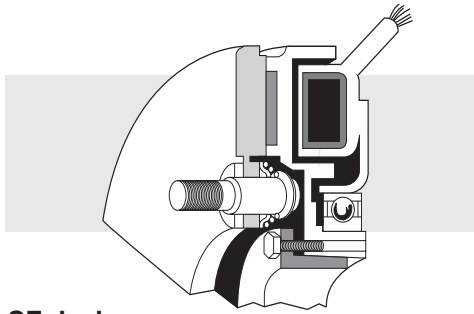

#### SF design Stationary Field Clutches

The SF design eliminates collector rings and brush holder. Ideal for adverse environmental conditions. Mounting tolerances are generally more critical than the PC design.

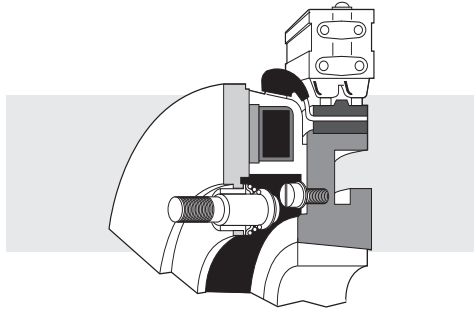

#### PC design Primary style clutches

Current is carried through brushes and the collector ring to the rotating magnet. The PC design is less expensive than the SF design.

### Antibacklash Armature



Warner Electric's spring-mounted antibacklash armature design, initially introduced for use in high-cycle-rate applications, is now available for sizes **120**, **170**, **250**, and **400** for general performance applications.

Here are some of their performance features:

- **Zero Backlash**

All backlash, or play, inherent in other armature designs is eliminated. Torque is transmitted through leaf springs which are riveted solidly to armature

### Antibacklash Armature

and hub.

- **Positive Disengagement**

The leaf springs which attach armature to hub pull the armature back sharply when the coil is deenergized, providing positive disengagement. Wear, heat, and noise caused by dragging armatures are eliminated.

- **Bi-Directional Operation**

Will operate equally well in both clockwise and counterclockwise directions.

- **Low Engagement Noise**

Leaf spring design isolates armature engagement vibration, effectively dampening engagement noise.

- **High Cycle Rate Capabilities**

Makes these armatures suitable for computer and business machine applications and other uses which require high cycle rates for extended periods.

- **Slotted Armatures for Greater Torque Stability**

Friction faces can withstand heat inputs without distortion.

Dimensions, part numbers, and specifications are listed in product descriptions for sizes **120**, **170**, **250** and **400** clutches and brakes.

### Autogap™ System

The Autogap is a system designed to separate the armature from the friction face. This spacing is automatic and occurs prior to total magnetic decay, effectively eliminating noise by preventing drag.

In Normal Duty units the autogap is incorporated as part of the drive pin assembly. In Heavy Duty units the autogap is incorporated as part of the armature/splined hub assembly.

The key advantage that the Warner Electric autogap system provides is automatic adjustment for wear, ensuring that the air gap between friction faces is the same throughout the life of the clutch or brake. This in turn provides:

- Consistent torque throughout the life of the unit
- Consistent engagement time throughout the life of the unit
- Freedom from maintenance adjustment.

For more detail on autogaps, see page 231.

### Normal duty vs. Heavy duty armature drives

#### Normal Duty

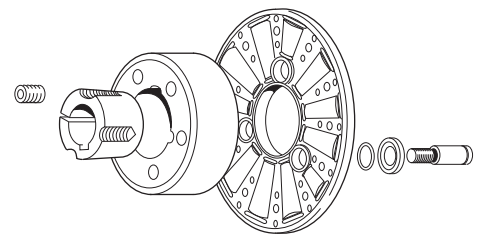

Torque is transmitted through three or four drive pins. Proven standard of the industry for all normal duty applications. Standard on clutches, brakes, motor brakes and clutch-brakes, size 500 to 1525.

#### Heavy Duty Drive

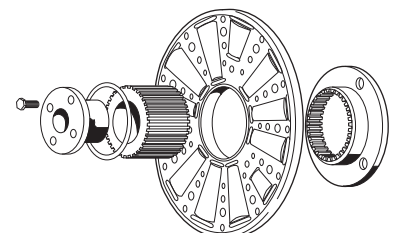

Torque is transmitted through a rugged splined hub to a mating splined adapter bolted to the armature. Designed for heavy cycle duty and shock loading applications. Standard on clutch couplings, clutch-brake couplings and Electro-Packs. Optional on brakes and clutches size 500 to 1525.

# Custom Design Clutches and Brakes

## Selection Clutches



### SF (Stationary Field Clutch)

Model Number	Max. Rated Torque	Outside Diameter (inches)	Overall Length (inches)	Page No.
SF-120	5 lb.in.	1-1/4	1-3/8	14, 16
SF-170	15 lb.in.	1-3/4	1-7/8	18, 20
SF-250	70 lb.in.	2-5/8	3-1/2	22, 24
SF-400	270 lb.in.	4-1/4	3-3/4	26, 28
SF-500	50 lb. ft.	5-1/4	4	30
SF-650	95 lb. ft.	6-3/4	3-3/8	32, 34
SF-825FM	125 lb. ft.	8-5/8	3	36, 40
SF-825BM	150 lb. ft.	8-5/8	2-3/4	38, 42
SF-1000FM	240 lb. ft.	10-3/8	3-1/8	44, 48
SF-1000BM	240 lb. ft.	10-3/8	3-1/8	46, 50
SF-1225FM	465 lb. ft.	12-3/4	3-3/4	52, 54
SF-1225BM	465 lb. ft.	12-3/4	3-3/4	56, 58
SF-1525FM	700 lb. ft.	15-3/4	4-1/4	60, 62
SF-1525BM	700 lb. ft.	15-3/4	4-1/4	64, 66
SF-1525H.T.FM	1,350 lb. ft.	15-3/4	5	68
SF-1525H.T.BM	1,350 lb. ft.	15-3/4	5	70



### PC (Primary Clutch)

Model Number	Max. Rated Torque	Outside Diameter (inches)	Overall Length (inches)	Page No.
PC-500	40 lb. ft.	6	3-1/4	72
PC-825	125 lb. ft.	9-1/4	3-1/2	74, 76
PC-1000	240 lb. ft.	10-7/8	3-7/8	78, 80
PC-1225	465 lb. ft.	12-7/8	4-1/2	82, 84
PC-1525	700 lb. ft.	16-1/8	4-3/4	86, 88

ND = Normal Duty  
 HD = Heavy Duty  
 HT = Hi Torque

## Clutch Couplings



### SFC (Stationary Field Clutch Coupling)

Model Number	Max. Rated Torque	Outside Diameter (inches)	Overall Length (inches)	Page No.
SFC-120	5 lb.in.	1-1/4	1	90, 92
SFC-170	15 lb.in.	1-3/4	1-3/8	94, 96
SFC-250	70 lb.in.	2-5/8	2-1/4	98, 100
SFC-400	270 lb.in.	4-1/4	2-3/4	102, 104
SFC-500	50 lb. ft.	5-1/4	3-7/8	106, 108
SFC-650	95 lb. ft.	6-3/4	3-5/8	110, 112
SFC-825FM	125 lb. ft.	8-5/8	4-3/8	114
SFC-825BM	150 lb. ft.	8-5/8	4-5/8	116
SFC-1000FM	240 lb. ft.	10-3/8	5-7/8	118
SFC-1000BM	240 lb. ft.	10-3/8	5-7/8	120
SFC-1225FM	465 lb. ft.	12-3/4	6-3/8	122
SFC-1225BM	465 lb. ft.	12-3/4	6-3/8	124
SFC-1525FM	700 lb. ft.	15-3/4	6-1/2	126
SFC-1525BM	700 lb. ft.	15-3/4	6-1/2	128
SFC-1525H.T.FM	1,350 lb. ft.	15-3/4	6-1/2	130
SFC-1525H.T.BM	1,350 lb. ft.	15-3/4	6-1/2	132



### PCC (Primary Clutch Coupling)

Model Number	Max. Rated Torque	Outside Diameter (inches)	Overall Length (inches)	Page No.
PCC-500	40 lb. ft.	6	4-1/4	134, 136
PCC-825	125 lb. ft.	9-1/4	4-3/8	138
PCC-1000	240 lb. ft.	10-7/8	5-7/8	140
PCC-1225	465 lb. ft.	12-7/8	6-1/2	142
PCC-1525	700 lb. ft.	16-1/8	6-3/4	144

ND = Normal Duty  
 HD = Heavy Duty



### Brakes



#### PB (Primary Brakes)

Model Number	Max. Rated Torque	Outside Diameter (inches)	Overall Length (inches)	Page No.
PB-120	5 lb.in.	1-1/4	1	146
PB-170	15 lb.in.	1-3/4	1-3/16	148
PB-250	70 lb.in.	2-5/8	2	150
PB-400	270 lb.in.	4-1/4	2-1/4	152
PB-500	40 lb. ft.	5-1/8	3	154, 156
PB-650	95 lb. ft.	6-1/2	2-7/8	158
PB-825	125 lb. ft.	8-5/8	3-1/2	160, 162
PB-1000	240 lb. ft.	10-1/4	4-1/8	164, 166
PB-1225	465 lb. ft.	12-5/8	5-3/8	168, 170
PB-1525	700 lb. ft.	15-1/2	4-1/2	172, 174



#### MB Motor Brakes

Model Number	Max. Rated Torque	Outside Diameter (inches)	Overall Length (inches)	Page No.
MB-825ND/HD	80 lb. ft.	11-1/2	4-1/4	176, 178
MB-1000ND/HD	160 lb. ft.	13-1/4	4-3/4	180, 182
MB-1225ND/HD	260 lb. ft.	15-3/4	5	184, 186

ND = Normal Duty  
HD = Heavy Duty

### Clutch/Brake Combinations



#### PCB Clutch/Brake (Primary Clutch Brake)

Model Number	Max. Rated Torque	Outside Diameter (inches)	Overall Length (inches)	Page No.
PCB-825ND/HD	125 lb. ft.	9-1/4	5-1/2	188, 190
PCB-1000ND/HD	240 lb. ft.	10-7/8	6	192, 194
PCB-1225ND/HD	465 lb. ft.	12-7/8	6-7/8	200, 202
PCB-1225/1000	465/240 lb. ft.	12-7/8	6-1/4	196, 198
PCB-1525/1225	700/465 lb. ft.	12-7/8	7-1/6	204, 206



#### SFPBC Clutch/Brake Coupling (Stationary Clutch Brake Coupling)

Model Number	Max. Rated Torque	Outside Diameter (inches)	Overall Length (inches)	Page No.
SFPBC-500	50/40 lb. ft.	5-1/4	5-3/8	208, 210
SFPBC-650	95 lb. ft.	6-3/4	5-1/4	212



#### PCBC Clutch/ Brake Coupling (Primary Clutch Brake Coupling)

Model Number	Max. Rated Torque	Outside Diameter (inches)	Overall Length (inches)	Page No.
PCBC-500ND/HD	40 lb. ft.	6	6	214, 216
PCBC-825	125 lb. ft.	9-1/4	6-1/4	218
PCBC-1000	240 lb. ft.	10-7/8	7-7/8	220
PCBC-1225	465 lb. ft.	12-7/8	8-3/4	224
PCBC-1225/1000	465/240 lb. ft.	16-1/8	8	220
PCBC-1525/1225	700/465 lb. ft.	16-1/8	9	226

ND = Normal Duty  
HD = Heavy Duty

# Custom Design Clutches and Brakes

## Selection

### Clutch Selection

Determine the shaft speed at the clutch location. The number listed at the intersection of the horsepower and speed lines is the size unit you require.

#### EXAMPLE: START APPLICATION

**Function:** To couple the output shaft of a motor in line with the input shaft of a reducer.

**Type:** A clutch coupling will couple two in line shafts.

**Size:** The motor horsepower is 1/2 and the speed is 1800 rpm. On the clutch chart opposite follow across the 1/2 HP line to the 1800 rpm column. A size 250 clutch coupling will handle this application.

### SELECTION CHARTS

The clutch selection charts are based on the following common power transmission formula:

#### CLUTCH TORQUE

$$T = \frac{K \times 5250 \times \text{HP}}{\text{RPM}}$$

**Where:** T = Torque (lb. ft.)

HP = Horsepower

RPM = Speed at clutch location

K = Motor overload factor

IF THERE IS A CHOICE OF LOCATIONS FOR THE CLUTCH OR BRAKE SELECT THE HIGHEST SPEED SHAFT. THE HIGHER THE SPEED – THE SMALLER THE CLUTCH OR BRAKE REQUIRED.

Unit installation at speeds below 100 rpm is not recommended, see page 244.

### Clutch – Horsepower vs. Shaft Speed

HP	SHAFT SPEED AT CLUTCH (IN RPM)																					
	100	200	300	400	500	600	700	800	900	1000	1100	1200	1500	1800	2000	2400	3000	3600	4000	4600	5000	
1/50																						
1/20										170												
1/12																						
1/8																						
1/6										250												
1/4																						
1/3																						
1/2										400												
3/4																						
1										500												
1-1/2																						
2										650												
3																						
5										825												
7-1/2																						
10										1000												
15																						
20										1225												
25										1525												
30																						
40										1525 H.T.												

### MOTOR OVERLOAD FACTOR

The motor overload factor K is the maximum or "pull-out" torque capacity of an electric motor. K is expressed as a percentage of the full load running torque. NEMA Design B motor are the standard general purpose design. The maximum torque of Design B motors has been used in the formulation of our selection charts.

Example: The maximum torque of a 2 HP, 1800 rpm, Design B motor is 275% of the full load running torque. In the clutch torque formula a motor overload factor of 2.75 would be used for K.

Clutches selected will therefore handle the maximum capacity of the motor. The motor would actually stall before the clutch would slip.

For determining the torque capacity required when the prime mover is not an electric motor the peak torques that could be encountered must be considered. Gasoline or diesel engines and compressors may require a K factor of 5.

In some instances a clutch selection can be made from the brake chart, page 9, if the maximum capacity of the clutch is not required until AFTER the load is accelerated to normal running speed. An example would be a lathe where the tool starts to cut AFTER the work piece is brought up to speed.

See page 6 for Index of available sizes.

See page 234 for Torque Curves.

See page 237 for Heat Dissipation Curves.

### NOTES ON SELECTION

### Brake Selection

Determine the shaft speed at the brake location. The number listed at the intersection of the horsepower and speed lines is the size unit you require. MOTOR BRAKE Frame Sizes are listed on product specification sheets.

#### EXAMPLES:

##### STOP APPLICATION

**Function:** To stop a lathe spindle.

**Type:** A brake will provide either a rapid or cushioned stop.

**Size:** The motor horsepower is 2 and the speed at the brake location is 1100 rpm. On the brake chart opposite follow across the 2 HP line to the 1100 rpm column. A size 500 brake will handle this application.

##### START-STOP APPLICATION

**Function:** To index a conveyor along a packing line.

**Type:** A clutch-brake will provide the start-stop index motion required. For this example the clutch-brake will be mounted on a jackshaft.

**Size:** The motor horsepower is 15 and the speed of the jackshaft is 900 rpm. From the clutch chart on page 8 a size 1225 clutch is required. From brake chart a size 1000 brake is required. Therefore, a size 1225/1000 clutch-brake combination would handle this application.

### SELECTION CHARTS

The clutch selection charts are based on the following common power transmission formula:

#### BRAKE TORQUE

$$T = \frac{5250 \times \text{HP}}{\text{RPM}}$$

**Where:** T = Torque (lb. ft.)

HP = Horsepower

RPM = Speed at brake location

**NOTE:** Motor overload factor K does not apply for brakes.

A brake selected will stop the load at least as fast as the time it takes the

### Brake – Horsepower vs. Shaft Speed

HP	SHAFT SPEED AT BRAKE (IN RPM)																					
	100	200	300	400	500	600	700	800	900	1000	1100	1200	1500	1800	2000	2400	3000	3600	4000	4600	5000	
1/50																						
1/20											170											
1/12																						
1/8																						
1/6											250											
1/4																						
1/3																						
1/2																						
3/4											400											
1																						
1-1/2																						
2											500											
3																						
5											650											
7-1/2																						
10											825											
15																						
20											1000											
25																						
30											1225											
40																						
50																						
60											1525											
75																						
100																						

motor to bring the load up to speed.

IF THERE IS A CHOICE OF LOCATIONS FOR THE CLUTCH OR BRAKE SELECT THE HIGHEST SPEED SHAFT. THE HIGHER THE SPEED – THE SMALLER THE CLUTCH OR BRAKE REQUIRED.

#### NOTES ON SELECTION:

See page 234 for Torque Curves.

See page 237 for Heat Dissipation Curves.

# Custom Design Clutches and Brakes

## Selection

### Torque Calculations

#### Based on Load Inertia and Time

$$T_{av} = \frac{WR^2N}{308t}$$

#### Where:

$WR^2$  = inertial load in terms of lb.ft.<sup>2</sup> referred to at the unit location.

N = RPM

t = time allowed for the engagement

T<sub>av</sub> = Average Torque (lb.ft.)

This formula gives us the torque (T) and is the average amount of torque required to accelerate a part from rest to a rotation of N revolutions per minute, about its axis, in t seconds, or decelerate a part from a rotation of N revolutions per minute about its axis to rest in t seconds.

#### Example Based on Inertia and Time

What is the average torque required to decelerate a total load of 1.0 lb.ft.<sup>2</sup> from 1750 rpm in .2 seconds?

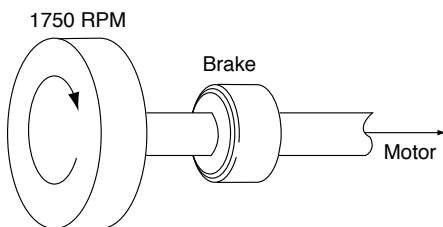

$WR^2$  total =

=  $WR^2$  load +  $WR^2$  clutch  
+ components

$WR^2 = 1 \text{ lb.ft.}^2$

$$T_{av} = \frac{WR^2N}{308t} = \frac{1(1750)}{308(.2)} = 28.4 \text{ lb.ft.}$$

#### Based on average torque,

A size 500 brake should be used.

(T<sub>av</sub> = 32 lb.ft.)

#### Based on Motor HP of Drive

The formula to use when calculating clutch torque requirement based on motor HP is:

$$T = \frac{5,250 \times \text{HP} \times 2.75^*}{N}$$

#### Where:

HP = name plate HP of the motor

\*K = motor overload factor = 2.75

N = RPM at the shaft where the clutch is located

All electric motors can exceed their rated torque for short periods of time during overload conditions. For a clutch to work properly in a system, therefore, the clutch must be designed to handle this overload torque without slipping. A 'K' factor of 2.75 is based on an average motor overload capability of common electric motors. Failure to include motor overload in clutch designs can lead to premature clutch failures as the clutch will have too little torque capacity to handle the overload output torque of the motor. The K factor is only used when calculating clutch torque. When selecting a brake, the K factor can be ignored since the brake is not stopping a driving motor. Therefore, the brake calculation for torque will be:

$$T = \frac{5,250 \times \text{HP}}{N}$$

#### Where:

HP = name plate HP of the motor

N = RPM must indicate the speed at the shaft where the brake will be mounted. This will account for torque changes as the result of speed reductions or increases.

### Torque and Horsepower Relationship

When selecting clutches and brakes Warner Electric disregards efficiency or frictional losses in pulley, sprocket or gearing drive trains. Torque on a clutch or brake will be greater or lesser than the torque at the motor shaft based on the speed differences between the motor shaft and the shaft where the clutch or brake is located. This is an inverse 1:1 relationship. A clutch at the slow speed side of a 10:1 ratio speed reduction will need to accelerate 10 times the torque as a clutch at the motor shaft. Conversely, a clutch at the high speed side of a 2:1 speed increase will accelerate half of the torque of a clutch at the motor shaft. Therefore, in selecting the best location to install a clutch and/or brake, the highest speed shaft that is available will allow for the smallest clutch or brake selection.

### Example:

#### Find Tc:

Speed at load

$$\frac{\text{Motor Speed}}{\text{Reduction}} = \frac{1,800}{20(2)} = 45 \text{ RPM}$$

$$T = \frac{5,250 \times \text{HP} \times K}{N} =$$

$$\frac{5,250 \times 10 \times 2.75}{20(2)} = 3,208 \text{ lb.ft.}$$

However, if clutch is located between motor and reducer:

$$T = \frac{5,250 \times 10 \times 2.75}{1,800} = 80.2 \text{ lb.ft.}$$

The selected clutch position should be made at the motor rather than the load. A size 1000 unit would do the job. (T = 90 lb.ft. at 1,800 RPM.)

For most installations, Warner Electric has devised simple selection charts on pages 8 and 9. The supporting data on each specific size clutch is on pages 234 and 235.

### Other considerations

#### Inertia

Complete information begins on page 239.

#### Heat Dissipation

Complete information begins on page 236.

#### Dynamic Torque

Complete information begins on page 234.

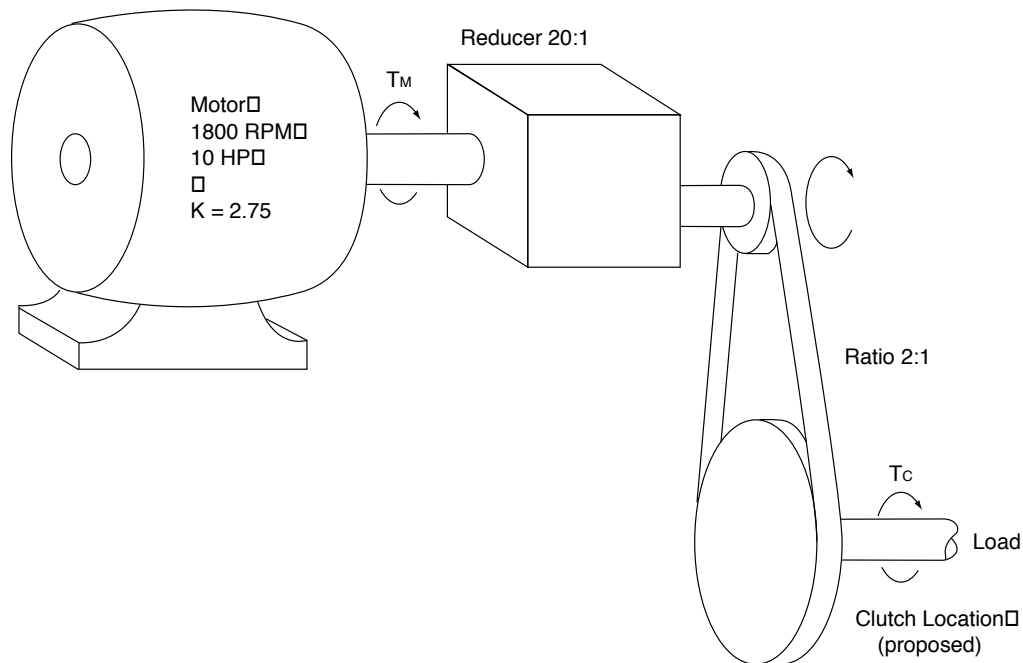

# Custom Design Clutches and Brakes

## Mounting Examples and Options

Warner Electric custom design brakes and clutches are economical to purchase and simple to install. They consist of components which must be assembled on the shaft and properly attached to the machine frame.

Various customer furnished drive components must be assembled with the brake or clutch. Pulleys, sprockets and bearings/pillow blocks for shafting may be essential elements of a complete drive system. Squareness and concentricity tolerances are specified where critical to proper clutch/brake functioning.

The illustrations show SF, PC and PCB units mounted with customer supplied bearing mounted pulley. In each illustration the drive pin for a normal duty clutch is shown. In this manner the pulley will support the armature.

### SF Clutches and SFC Clutch Couplings

#### Flange Mounting

Concentricity tolerances, held by customer, are critical. Pilot surface required on machine member. Eliminates bearings. Good design for high speed applications.

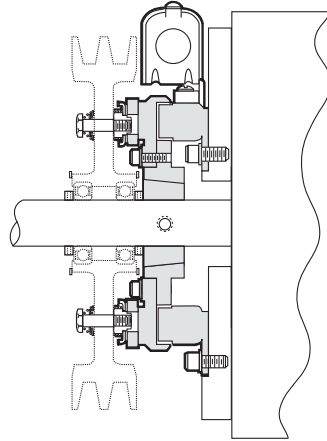
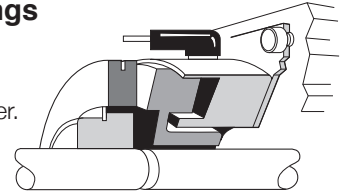

**SF Clutch**  
Typical Installation

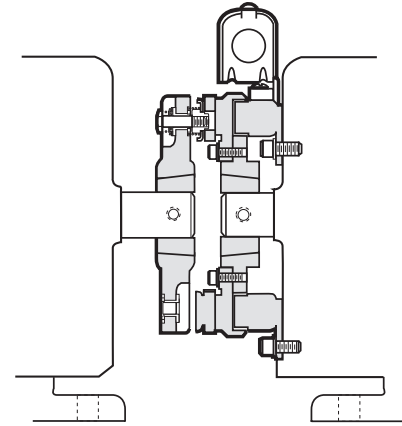

**SFC Clutch Coupling**  
Typical Installation

#### Bearing Mounting

Bearing supports field and holds close tolerances required between rotor and field. Easy to install and priced about the same as the flange mounted design.

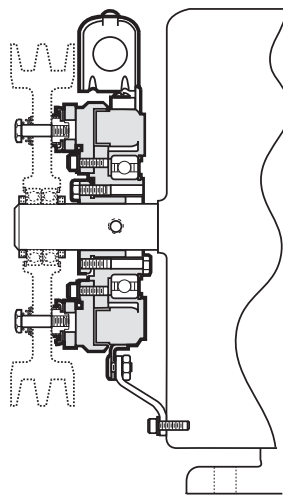
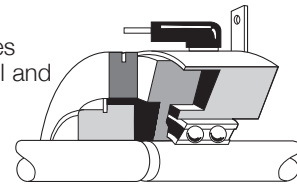

**SF Clutch**  
Typical Installation

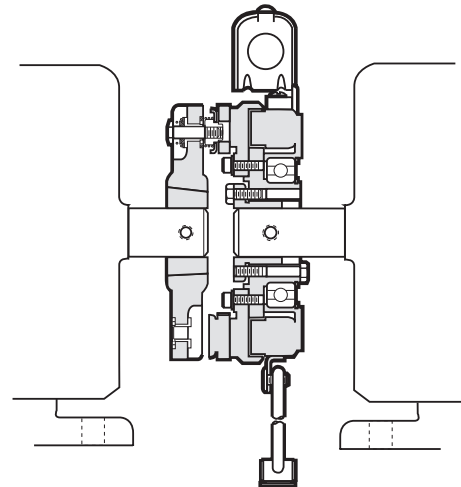

**SFC Clutch Coupling**  
Typical Installation

## Mounting Examples and Options

### PC Clutches and PCC Clutch Couplings

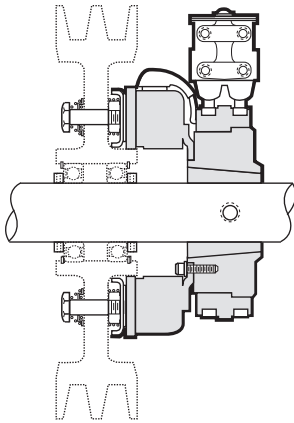

**PC Clutch**  
Typical Installation  
(Left hand hub shown)

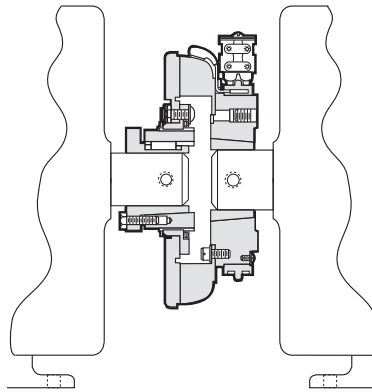

**PCC Clutch Coupling**  
Typical Installation

### Left Hand vs. Right Hand Hubs

Left handed or right handed Taperlock bushing installation

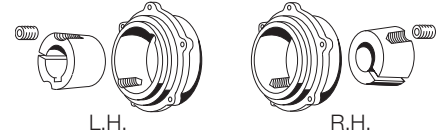

L.H.  
Taperlock bushing enters from magnet side. Mounting screws accessible from magnet size only.

R.H.  
Taperlock bushing enters from opposite side.

### PB Brakes

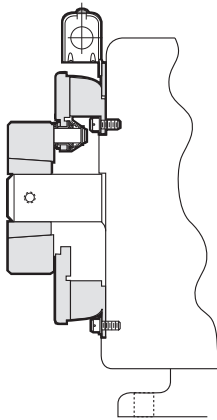

**PB Brake**  
Typical Installation

### Inside or Outside Mounting Option



**Inside mount**  
Mounting screws for the magnet are accessible from inside the magnet only.

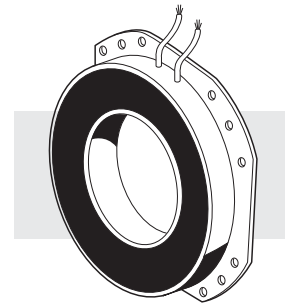

**Outside Mount**  
Mounting screws for the magnet are accessible on the outside of the magnet. Outside mounted units cost slightly more.

### Clutch/Brake Combinations

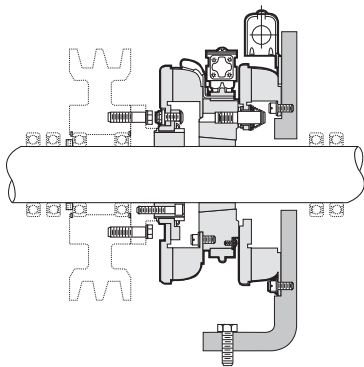

**PCB Clutch/Brake**  
Typical Installation

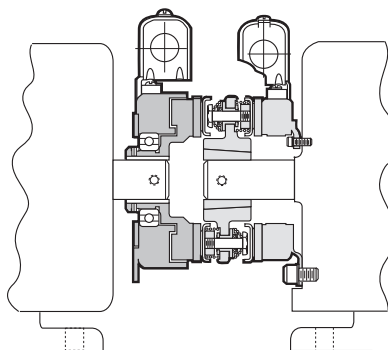

**SFPBC Clutch/Brake Coupling**  
Typical Installation

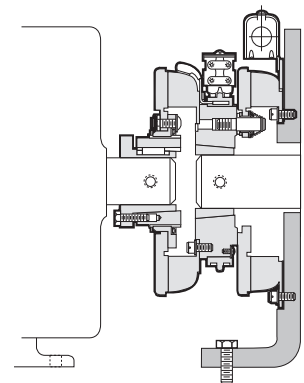

**PCBC Clutch/Brake Coupling**  
Typical Installation

# Clutch

## SF-120 Flange Mounted

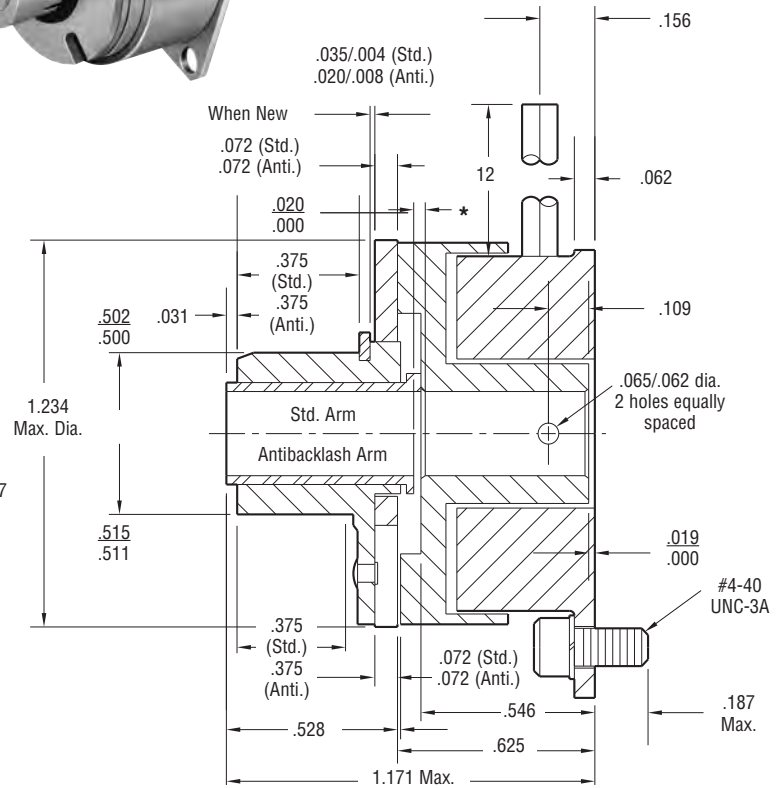
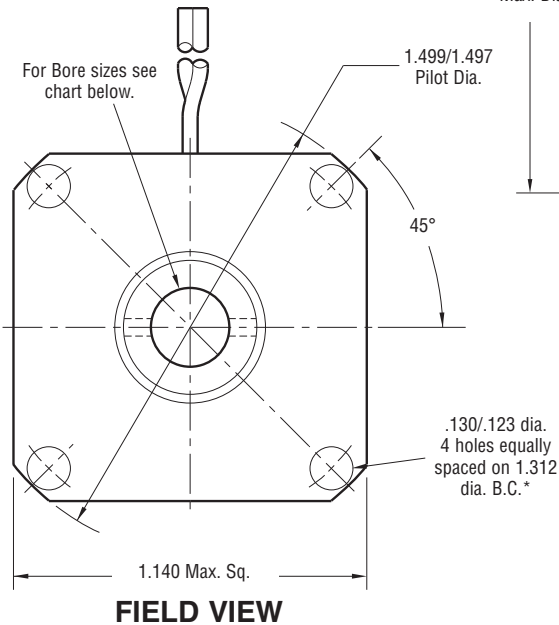
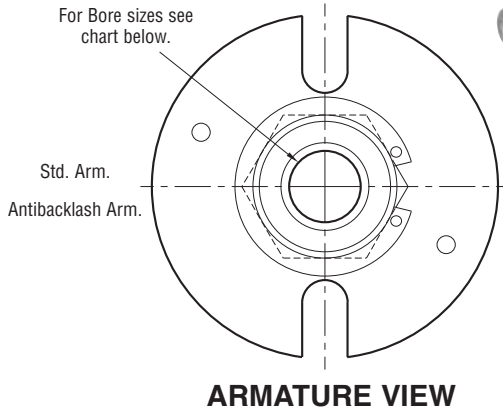
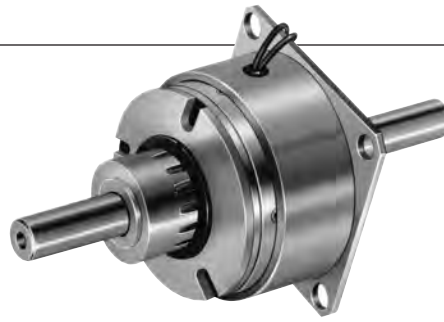

\* Mounting holes are within .006 of true position relative to pilot diameter.

### Bore Dimensions

Rotor Bore Dia.	Armature Bore Dia.
.188/.187	.195/.190
.251/.250	.257/.252
.313/.312	—

Static Torque	5 lb.in.
Maximum Speed	3,600 rpm
Standard Voltage	D.C. 6, 24, 90

All dimensions are nominal unless otherwise noted.

Information on inertia and weights begins on page 239. Coil data is on pages 250 and 251.





SF-120 Flange Mounted

Drawing I-25508

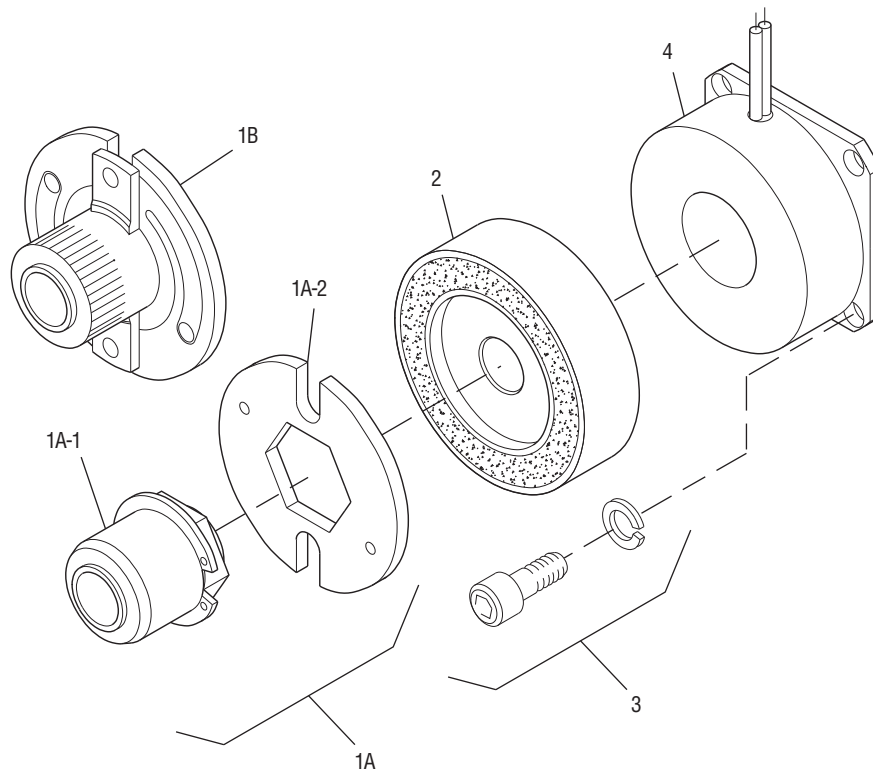

Item	Description	Part Number	Qty.
1A	Armature and Hub		
1A-1	Armature Hub		1
	3/16" Bore	5602-541-009	
	1/4" Bore	5602-541-008	
1A-2	Armature	110-0110	1
1B	Antibacklash Armature		1
	3/16" Bore	5602-111-002	
	1/4" Bore	5602-111-003	
	5/16" Bore	5602-111-007	
2	Rotor		1
	3/16" Bore	5602-751-004	
	1/4" Bore	5602-751-002	
	5/16" Bore	5602-751-003	
3	Mounting Accessory	5101-101-001	1
4	Field		1
	6 Volt	5602-451-003	
	24 Volt	5602-451-005	
	90 Volt	5602-451-007	

**How to Order:**

1. Specify Type of Armature Desired.
2. Specify Bore Size for Item 1A-1 or 1B and Item 2.
3. Specify Voltage for Item 4.
4. See Controls Section.

**Example:**

SF-120 Clutch per I-25508 - 90 Volt  
 Standard Armature  
 1/4" Armature Hub Bore  
 1/4" Rotor Bore

These units meet standards set forth in UL508 and are listed under guide card #NMTR2, file #59164.

These units are CSA certified under file #LR11543.

Refer to Service Manual P-200.

# Clutch

## SF-120 Bearing Mounted

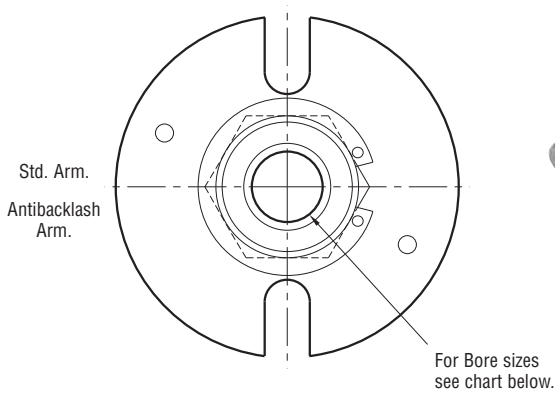
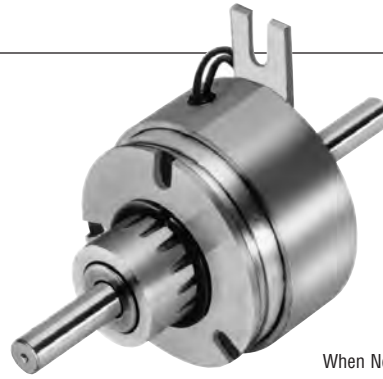

**ARMATURE VIEW**

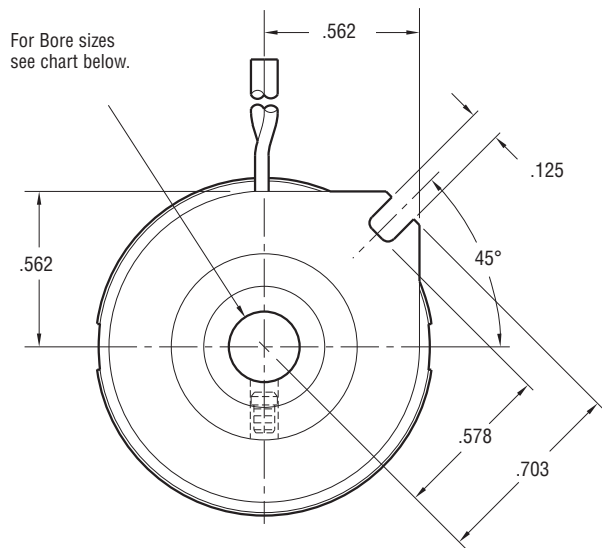

**FIELD VIEW**

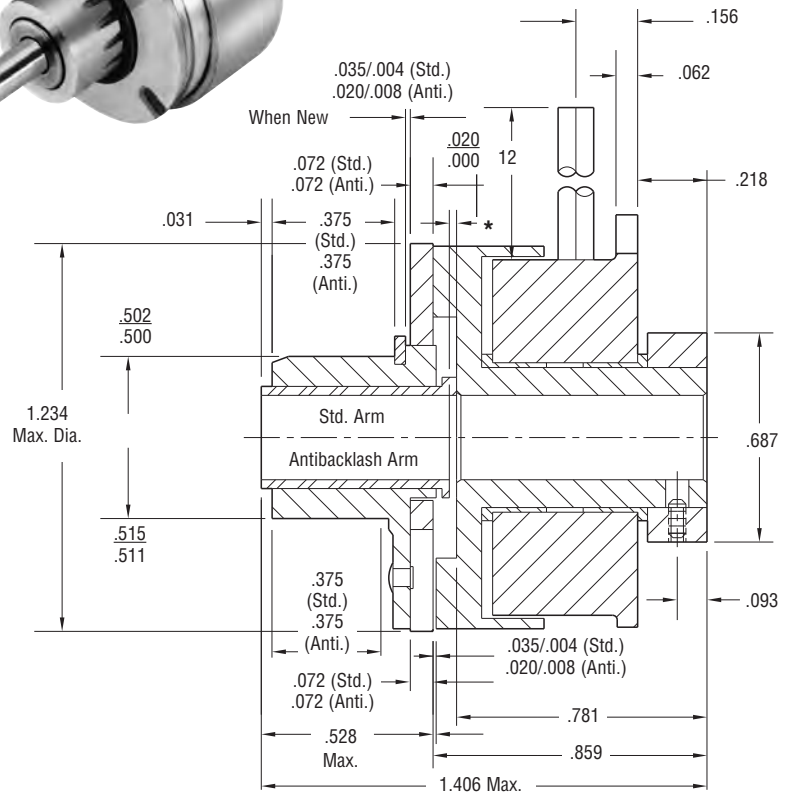

\*Customer shall maintain dimension as noted.

### Bore Dimensions

Rotor Bore Dia.	Armature Bore Dia.
.188/.187	.195/.190
.251/.250	.257/.252
.313/.312	—

Static Torque	5 lb.in.
Maximum Speed	3,600 rpm
Standard Voltage	D.C. 6, 24, 90

All dimensions are nominal unless otherwise noted.

Information on inertia and weights begins on page 239. Coil data is on pages 250 and 251.



SF-120 Bearing Mounted

Drawing I-25509

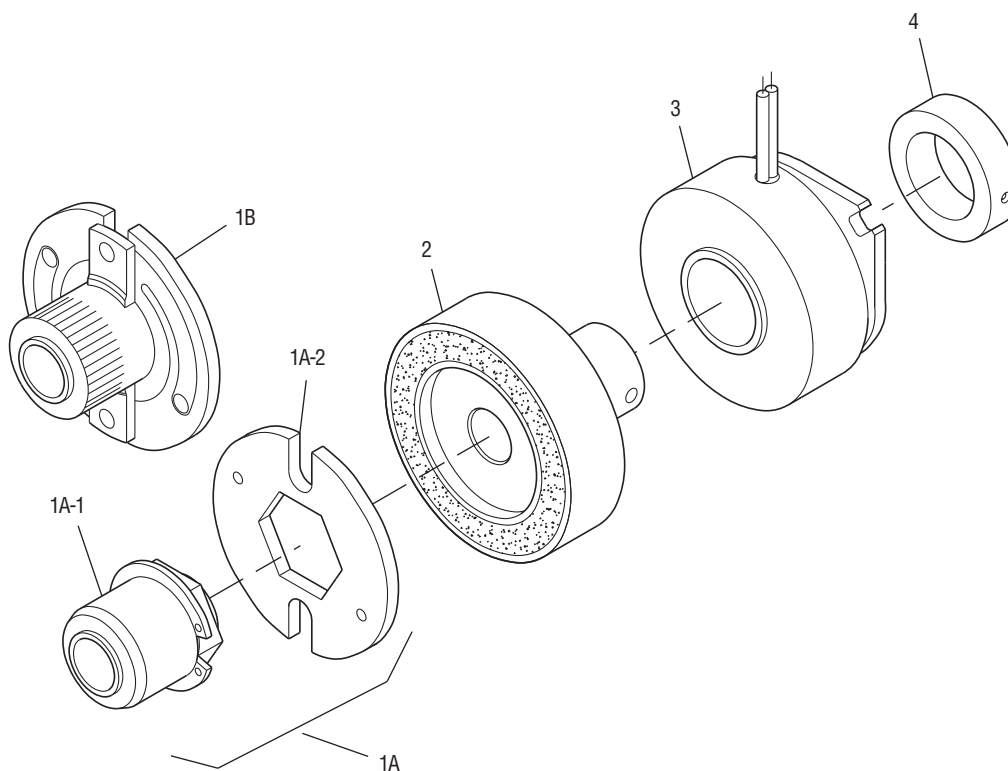

Item	Description	Part Number	Qty.
1A	Armature and Hub		
1A-1	Armature Hub		1
	3/16" Bore	5602-541-009	
	1/4" Bore	5602-541-008	
1A-2	Armature	110-0110	1
1B	Antibacklash Armature		1
	3/16" Bore	5602-111-002	
	1/4" Bore	5602-111-003	
	5/16" Bore	5602-111-007	
2	Rotor		1
	3/16" Bore	5602-751-008	
	1/4" Bore	5602-751-006	
	5/16" Bore	5602-751-007	
3	Field		1
	6 Volt	5602-451-021	
	24 Volt	5602-451-023	
	90 Volt	5602-451-025	
4	Set Collar	5602-266-001	1

**How to Order:**

1. Specify Type of Armature Desired.
2. Specify Bore Size for Item 1A-1 or 1B and Item 2.
3. Specify Voltage for Item 3.
4. See Controls Section.

**Example:**

SF-120 Clutch per I-25509 - 90 Volt  
Standard Armature  
1/4" Armature Hub Bore

These units meet standards set forth in UL508 and are listed under guide card #NMTR2, file #59164.

These units are CSA certified under file #LR11543.

Refer to Service Manual P-200.

# Clutch

## SF-170 Flange Mounted

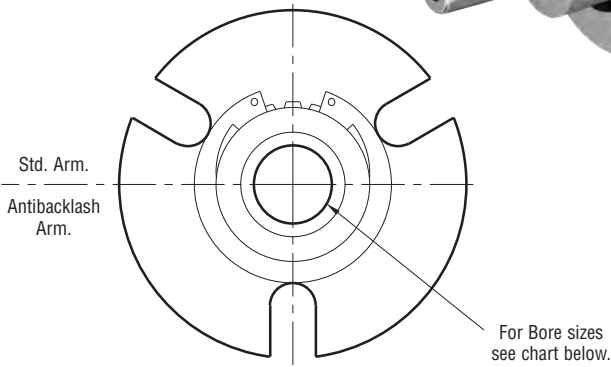
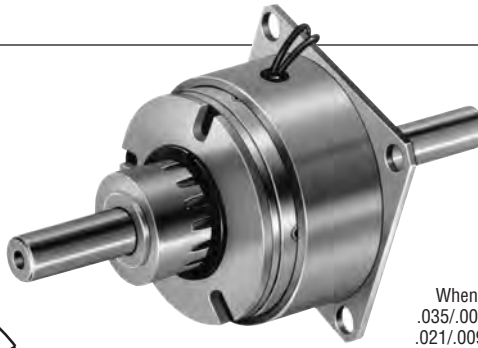

**ARMATURE VIEW**

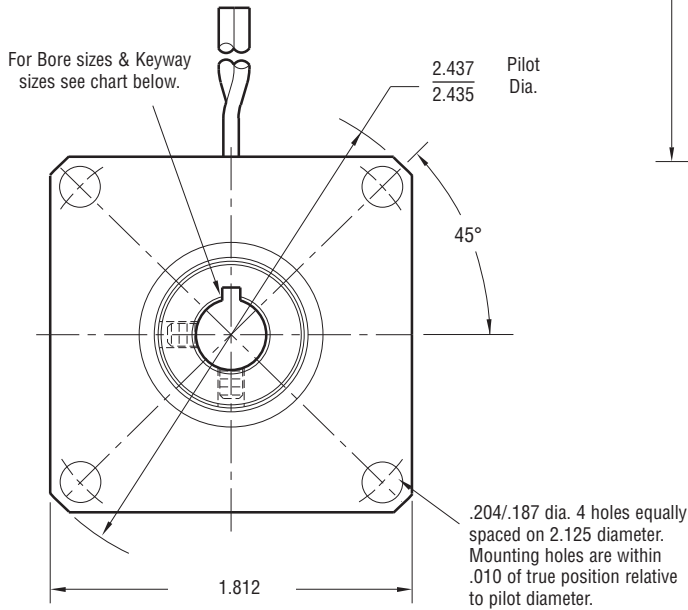

**FIELD VIEW**

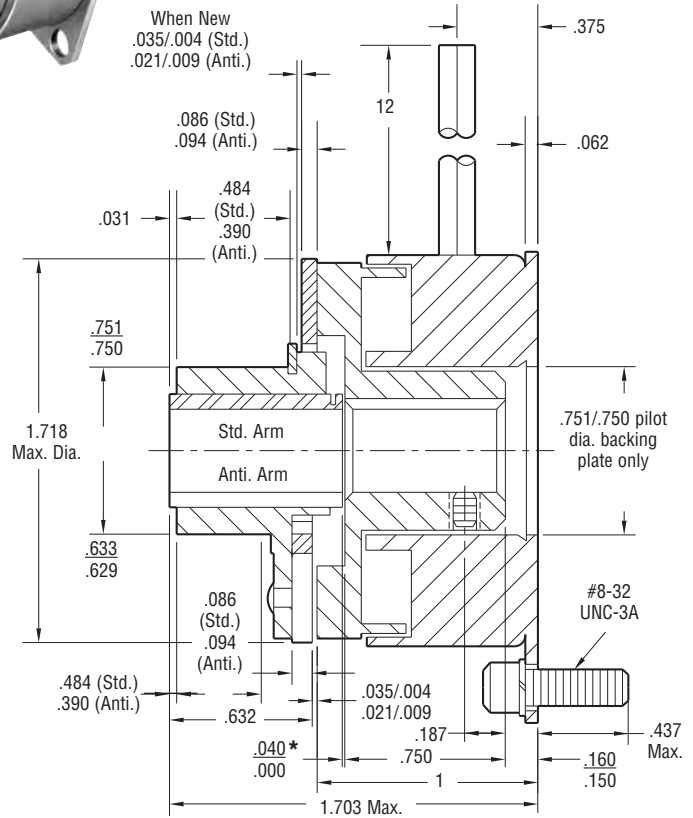

\*Diameter over knurl.

### Rotor Bore Dimensions

Rotor Bore Dia.	Keyway	Armature Bore Dia.
.251/.250	.062/.031	.2522/.2507
.313/.312	.062/.031	.3145/.3130
.376/.375	.093/.047	.3773/.3755

Static Torque	15 lb.in.
Maximum Speed	5,000 rpm
Standard Voltage	D.C. 6, 24, 90

All dimensions are nominal unless otherwise noted.

Information on inertia and weights begins on page 239. Coil data is on pages 250 and 251.

### Customer Shall Maintain:

1. Squareness of field mounting face with shaft with .003 T.I.R. measured at pilot diameter.
2. Concentricity of field mounting pilot diameter with rotor mounting shaft within .003 T.I.R.



SF-170 Flange Mounted

Drawing I-25754

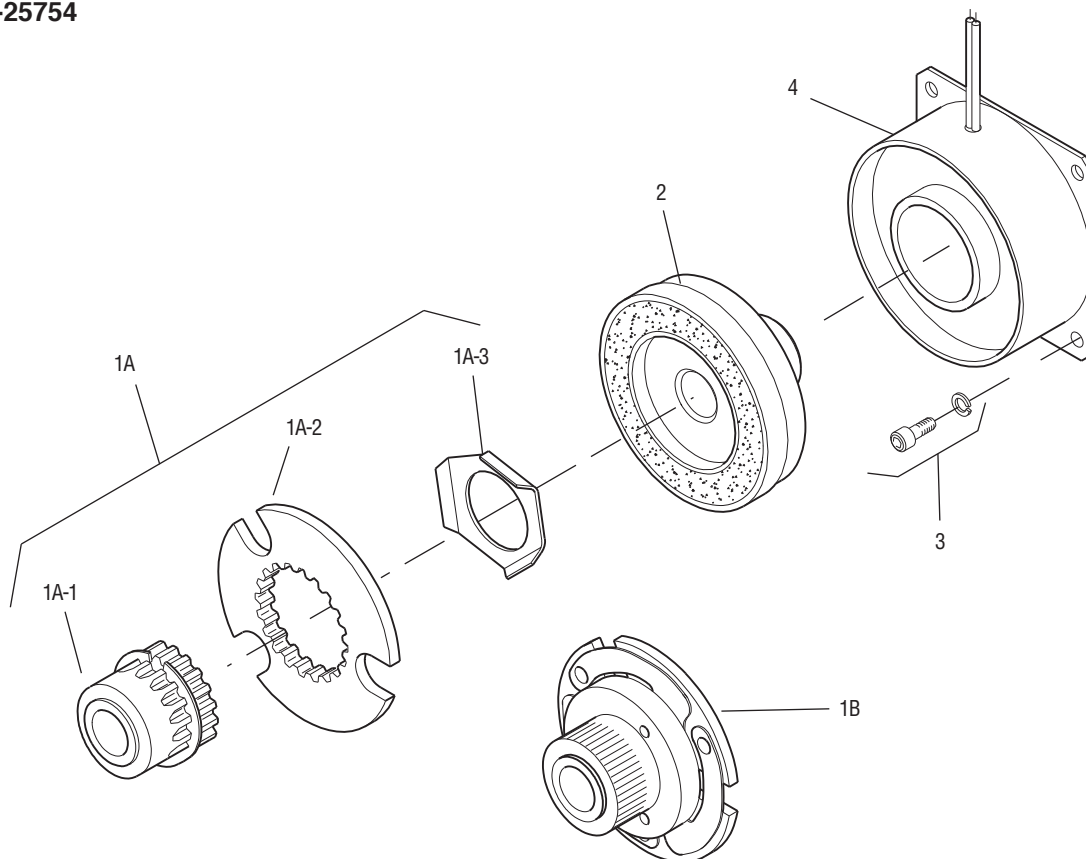

Item	Description	Part Number	Qty.
1A	Armature and Hub		
1A-1	Armature Hub		1
	1/4" Bore	5123-541-002	
	5/16" Bore	5123-541-003	
	3/8" Bore	5123-541-004	
1A-2	Armature	110-0111	1
1A-3	Release Spring	808-0019	1
1B	Antibacklash Armature		1
	1/4" Bore	5603-111-033	
	5/16" Bore	5603-111-034	
	3/8" Bore	5603-111-035	
2	Rotor		1
	1/4" Bore	5603-751-028	
	5/16" Bore	5603-751-029	
	3/8" Bore	5603-751-030	
3	Mounting Accessory	5102-101-001	1
4	Field		1
	6 Volt	5603-451-047	
	24 Volt	5603-451-049	
	90 Volt	5603-451-051	

**How to Order:**

1. Specify Type of Armature Desired.
2. Specify Bore Size for Item 1A-1 or 1B and Item 2.
3. Specify Voltage for Item 4.
4. See Controls Section.

**Example:**

SF-170 Clutch per I-25754 - 90 Volt  
 Antibacklash Armature  
 1/4" Armature Hub Bore  
 1/4" Rotor Bore

These units meet standards set forth in UL508 and are listed under guide card #NMTR2, file #59164.

These units are CSA certified under file #LR11543.

Refer to Service Manual P-200.

# Clutch

## SF-170 Bearing Mounted

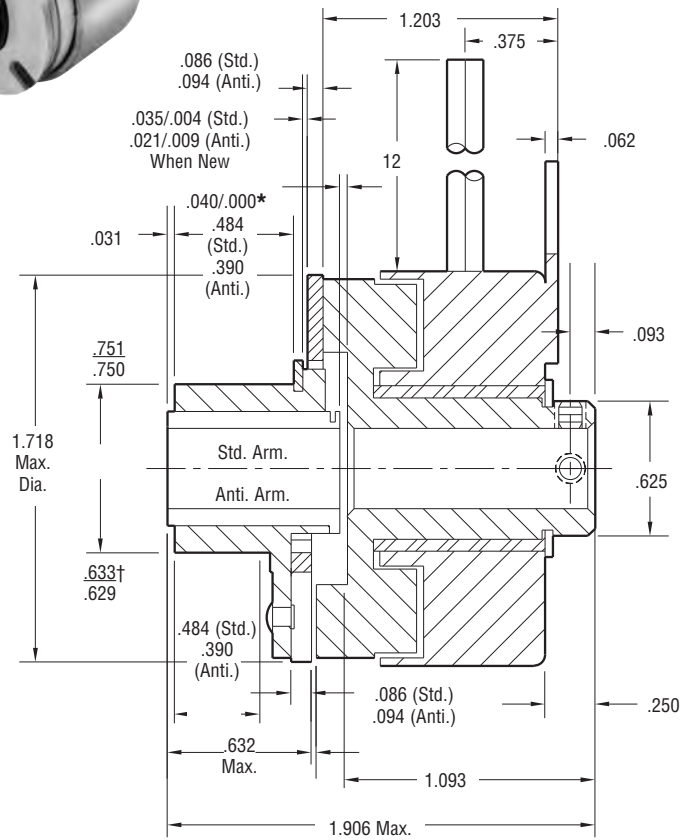
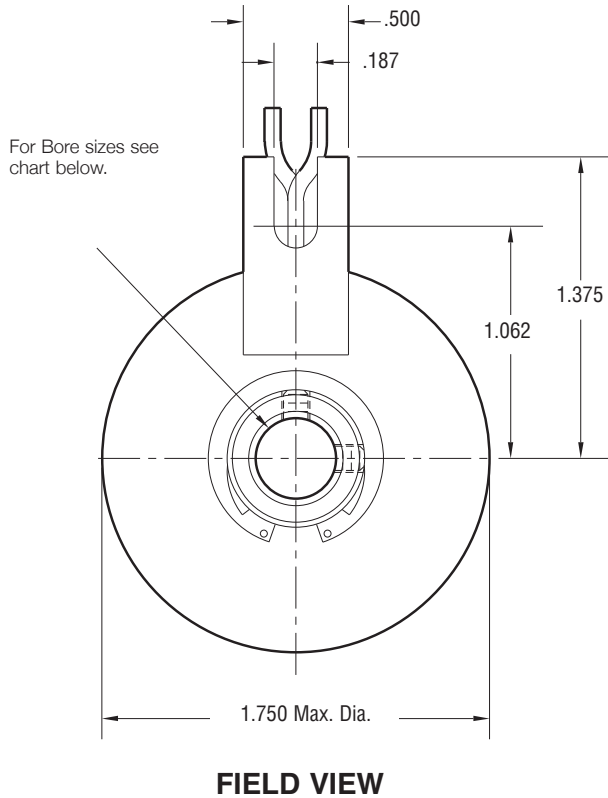
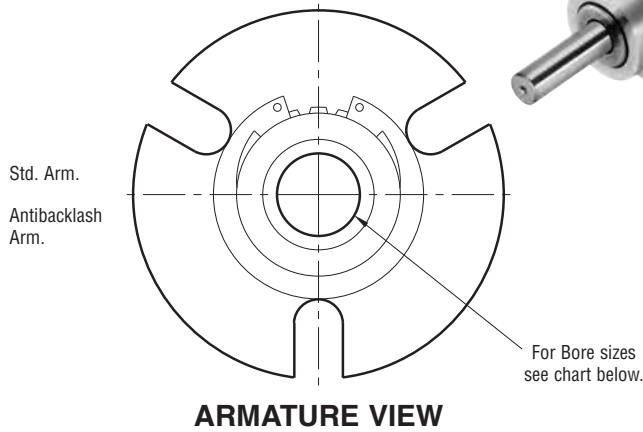
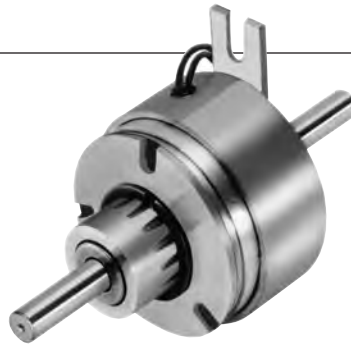

### Bore Dimensions

Rotor Bore Dia.	Armature Bore Dia.
.251/.250	.2522/.2507
.313/.312	.3145/.3130
.376/.375	.3773/.3755

Static Torque	15 lb.in.
Maximum Speed	5,000 rpm
Standard Voltage	D.C. 6, 24, 90

All dimensions are nominal unless otherwise noted.

Information on inertia and weights begins on page 239. Coil data is on pages 250 and 251.

### Customer Shall Maintain:

\*Customer shall maintain dimension as noted.

† over knurl



SF-170 Bearing Mounted

Drawing I-25755

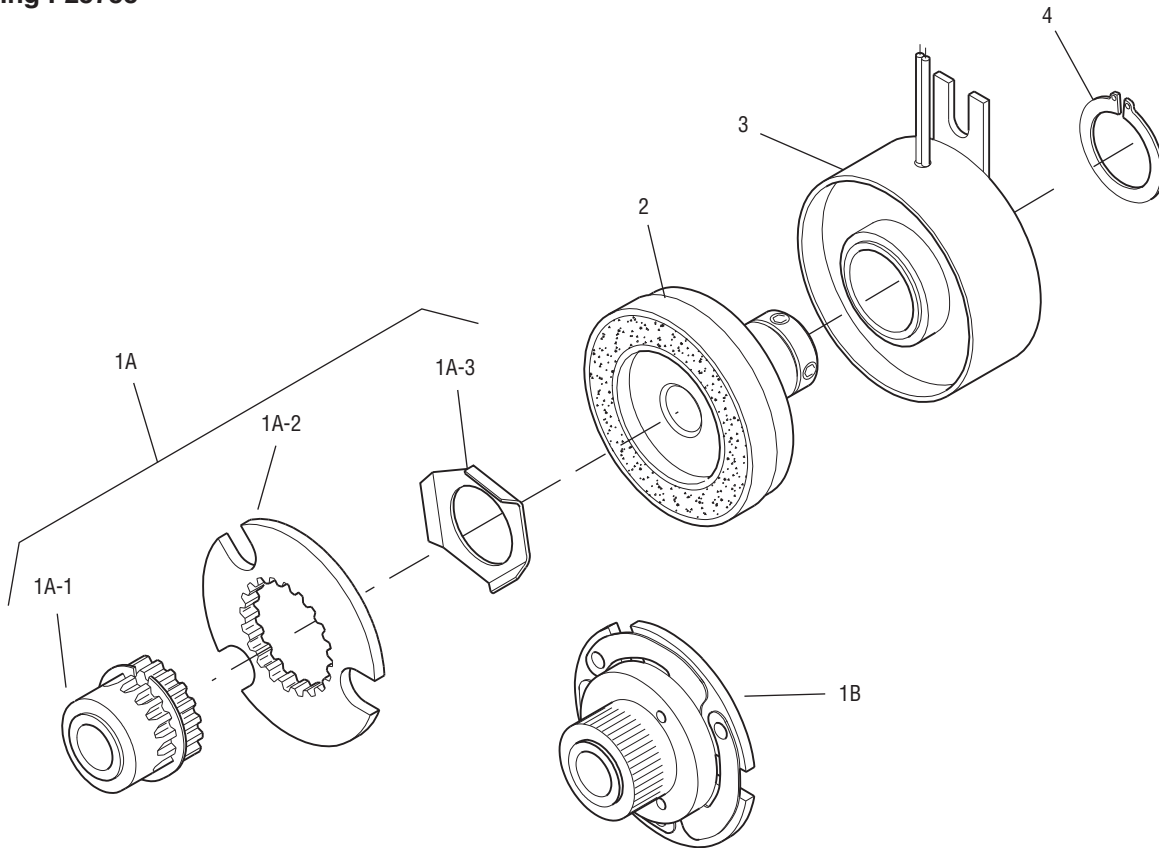

Item	Description	Part Number	Qty.
1A	Armature and Hub		
1A-1	Armature Hub		1
	1/4" Bore	5123-541-002	
	5/16" Bore	5123-541-003	
	3/8" Bore	5123-541-004	
1A-2	Armature	110-0111	1
1A-3	Release Spring	808-0019	1
1B	Antibacklash Armature		1
	1/4" Bore	5603-111-033	
	5/16" Bore	5603-111-034	
	3/8" Bore	5603-111-035	
2	Rotor		1
	1/4" Bore	5603-751-019	
	5/16" Bore	5603-751-021	
	3/8" Bore	5603-751-020	
3	Field		1
	6 Volt	5603-451-039	
	24 Volt	5603-451-041	
	90 Volt	5603-451-043	
4	Retainer Ring	748-0024	1

**How to Order:**

1. Specify Type of Armature Desired.
2. Specify Bore Size for Item 1A-1 or 1B and Item 2.
3. Specify Voltage for Item 3.
4. See Controls Section.

**Example:**

SF-170 Clutch per I-25755 - 90 Volt  
Antibacklash Armature  
1/4" Armature Hub Bore

These units meet standards set forth in UL508 and are listed under guide card #NMTR2, file #59164.

These units are CSA certified under file #LR11543.

Refer to Service Manual P-200.

# Clutch

## SF-250 Flange Mounted

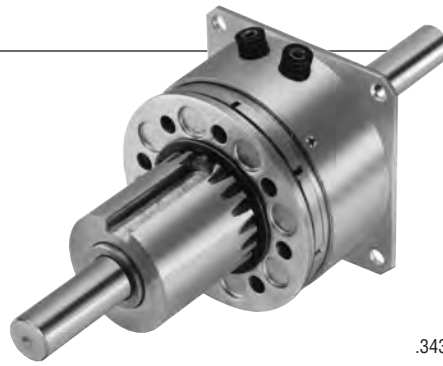

For Bore & Keyway sizes see chart below.

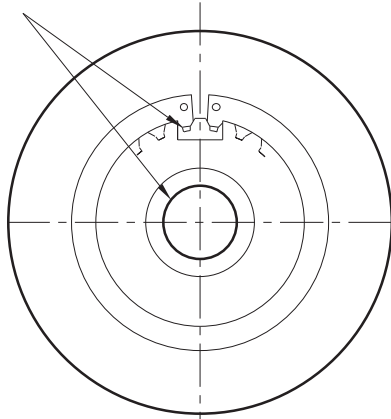

**ARMATURE VIEW**

For Bore & Keyway sizes see chart below.

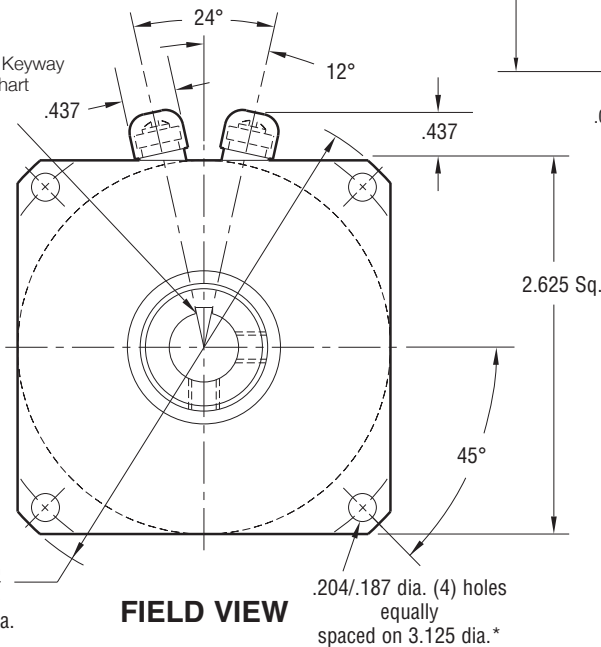

**FIELD VIEW**

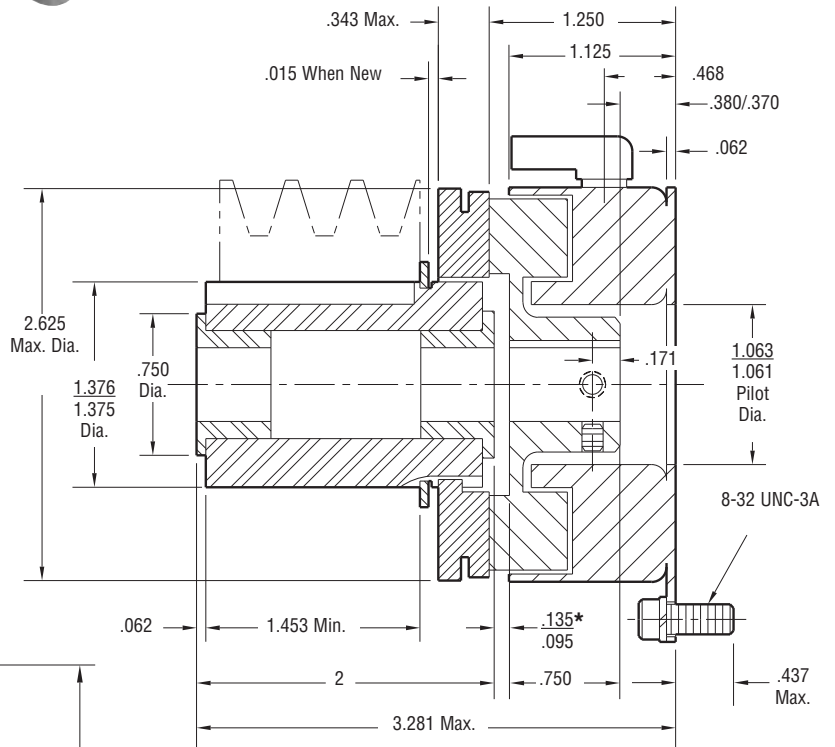

\*Customer shall maintain dimension as noted.

### Bore and Keyway Dimensions

Armature Bore Dia.	Keyway	Rotor Bore Dia.	Keyway
.3750/.3745		.376/.375	.093 x .046
.5000/.4995	.312 x .156	.438/.437	.125 x .031
*.5625/.5620	x 1.250	.501/.500	.125 x .031
.6250/.6245			

\*Available on special order only.

Static Torque	70 lb.in.
Maximum Speed	7,500 rpm
Standard Voltage	D.C. 6, 24, 90

All dimensions are nominal unless otherwise noted.

Information on inertia and weights begins on page 239. Coil data is on pages 250 and 251.

### Customer Shall Maintain:

1. Squareness of field mounting face with shaft within .003 T.I.R. measured at pilot diameter.
2. Concentricity of field mounting pilot diameter with rotor mounting shaft within .003 T.I.R.

\*Mounting holes are within .010 of true position relative to pilot diameter.





SF-250 Flange Mounted

Drawing I-25520

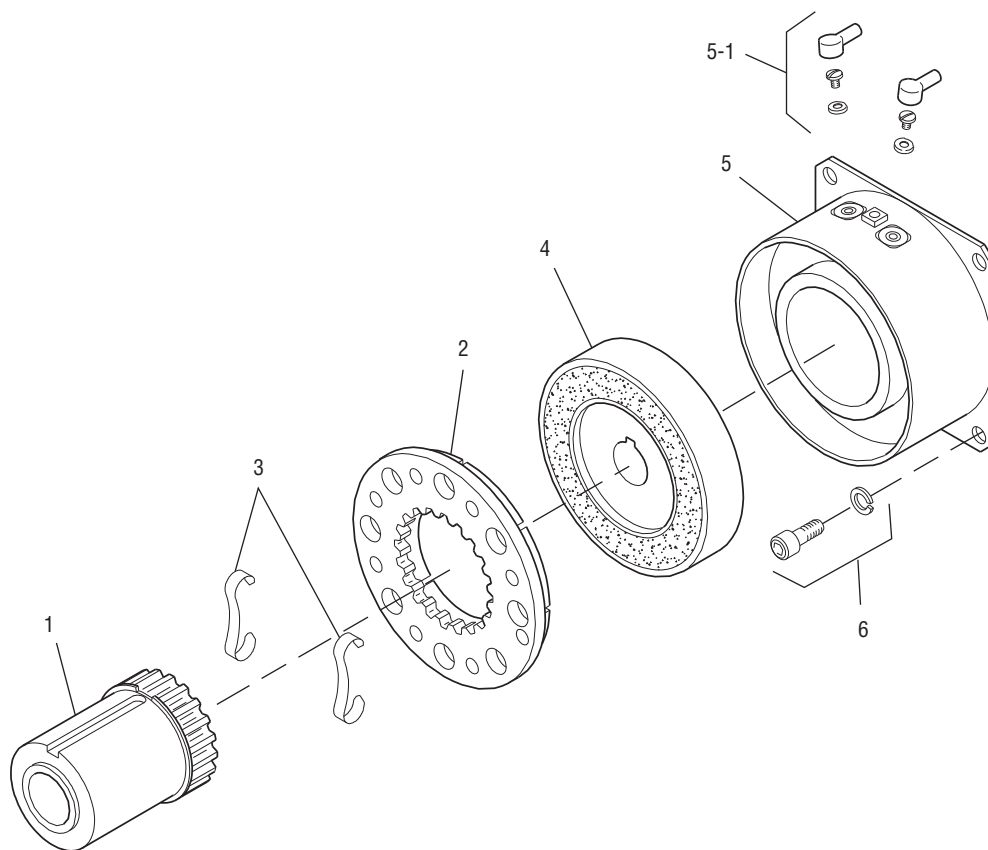

Item	Description	Part Number	Qty.
1	Armature Hub		1
	3/8" Bore	5124-541-002	
	1/2" Bore	5124-541-003	
	5/8" Bore	5124-541-005	
2	Armature	5124-111-001	1
3	Release Spring	5103-101-003	1
4	Rotor		1
	3/8" Bore	5103-751-008	
	1/2" Bore	5103-751-010	
5	Field		1
	6 Volt	5103-451-002	
	24 Volt	5103-451-004	
	90 Volt	5103-451-007	
5-1	Terminal Accessory	5103-101-002	1
6	Mounting Accessory	5102-101-001	1

**How to Order:**

1. Specify Bore Size for Item 1 and Item 4.
2. Specify Voltage for Item 5.
3. See Controls Section.

**Example:**

SF-250 Clutch per I-25520 - 90 Volt  
 3/8" Armature Hub Bore  
 3/8" Rotor Bore

These units meet standards set forth in UL508 and are listed under guide card #NMTR2, file #59164.

These units are CSA certified under file #LR11543.

Refer to Service Manual P-200.

# Clutch

## SF-250 Bearing Mounted

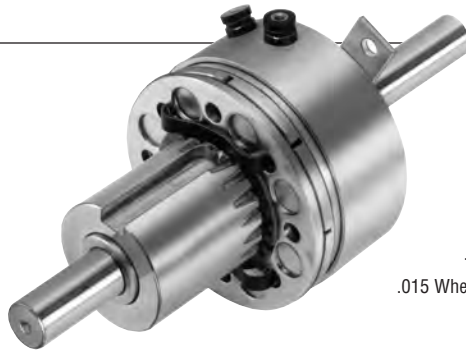

For Bore & Keyway sizes see chart below.

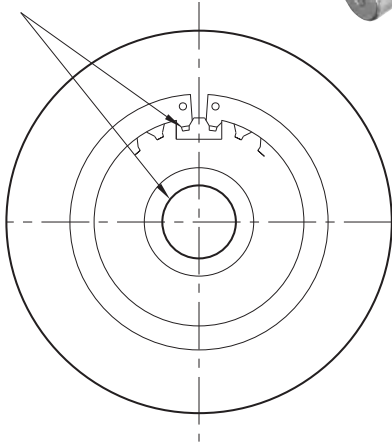

**ARMATURE VIEW**

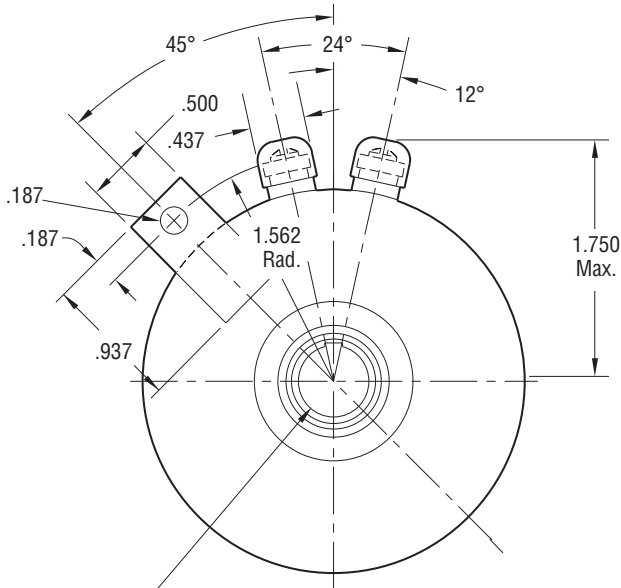

For Bore & Keyway sizes see chart below.

**FIELD VIEW**

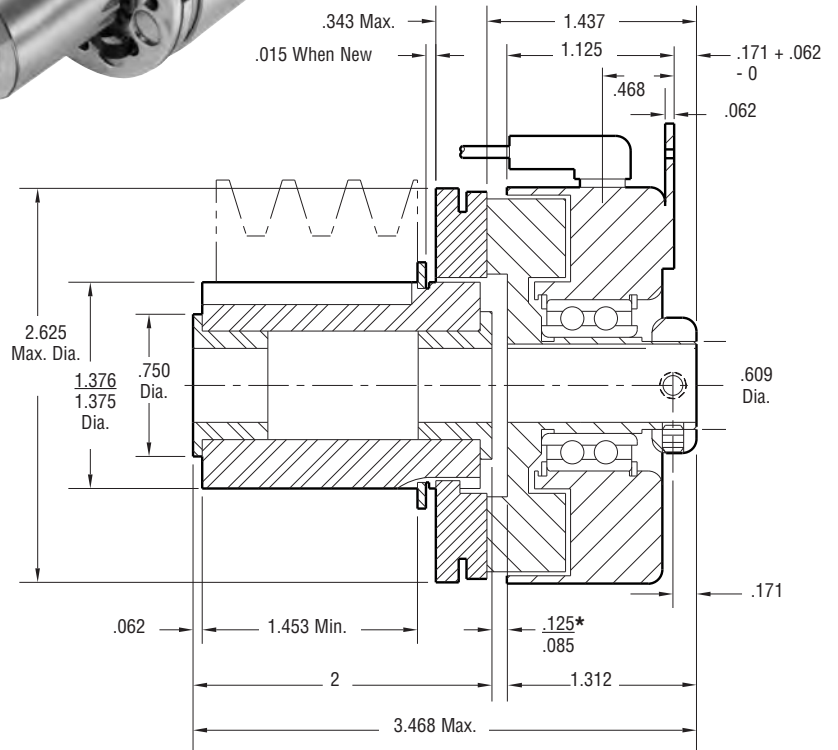

\*Customer shall maintain dimension as noted.

### Bore and Keyway Dimensions

Armature Bore Dia.	Keyway	Rotor Bore Dia.	Keyway
.3750/.3745		.376/.375	.093 x .046
.5000/.4995	.312 x .156	.438/.437*	.125 x .062
.5625/.5620*	x 1.25	.501/.500	.125 x .062
.6250/.6245			

\* Available on special order only.

Static Torque	70 lb.in.
Maximum Speed	7,500 rpm
Standard Voltage	D.C. 6, 24, 90

All dimensions are nominal unless otherwise noted.

Information on inertia and weights begins on page 239. Coil data is on pages 250 and 251.



## SF-250 Bearing Mounted

Drawing I-25521

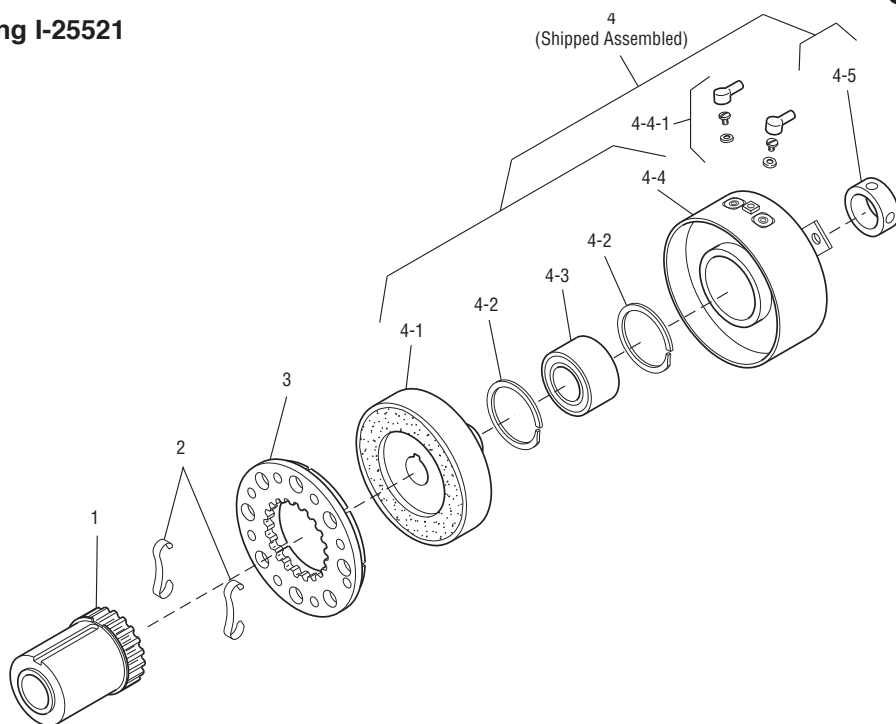

Item	Description	Part Number	Qty.
1	Armature Hub		1
	3/8" Bore	5124-541-002	
	1/2" Bore	5124-541-003	
	5/8" Bore	5124-541-005	
2	Release Spring Optional	5103-101-003	1
3	Armature	5124-111-001	1
4	Field and Rotor Assembly		1
	6 Volt – 3/8" Bore	5103-452-002	
	24 Volt – 3/8" Bore	5103-452-004	
	90 Volt – 3/8" Bore	5103-452-007	
	6 Volt – 1/2" Bore	5103-452-016	
	24 Volt – 1/2" Bore	5103-452-018	
	90 Volt – 1/2" Bore	5103-452-021	
4-1	Rotor		1
	3/8" Bore	5103-751-014	
	1/2" Bore	5103-751-016	
4-2	Retainer Ring	748-0371	2
4-3	Ball Bearing	166-0108	1
4-4	Field		1
	6 Volt	5103-451-018	
	24 Volt	5103-451-020	
	90 Volt	5103-451-023	
4-4-1	Terminal Accessory	5103-101-002	1
4-5*	Set Collar	266-0005	1

\*Used with 1/2" Bore only.

### How to Order:

1. Specify Bore Size for Item 1 and Item 4.
2. Specify Voltage for Item 4.
3. See Controls Section.

### Example:

SF-250 Clutch per I-25521 - 90 Volt  
 1/2" Armature Hub Bore  
 1/2" Rotor Bore

These units meet standards set forth in UL508 and are listed under guide card #NMTR2, file #59164.

These units are CSA certified under file #LR11543.

Refer to Service Manual P-200.

# Clutch

## SF-400 Flange Mounted



For Bore & Keyway sizes see chart below.

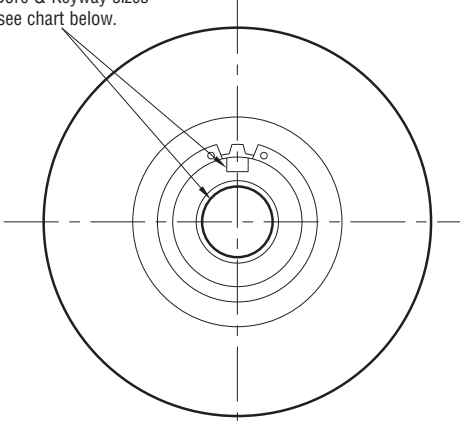

**ARMATURE VIEW**

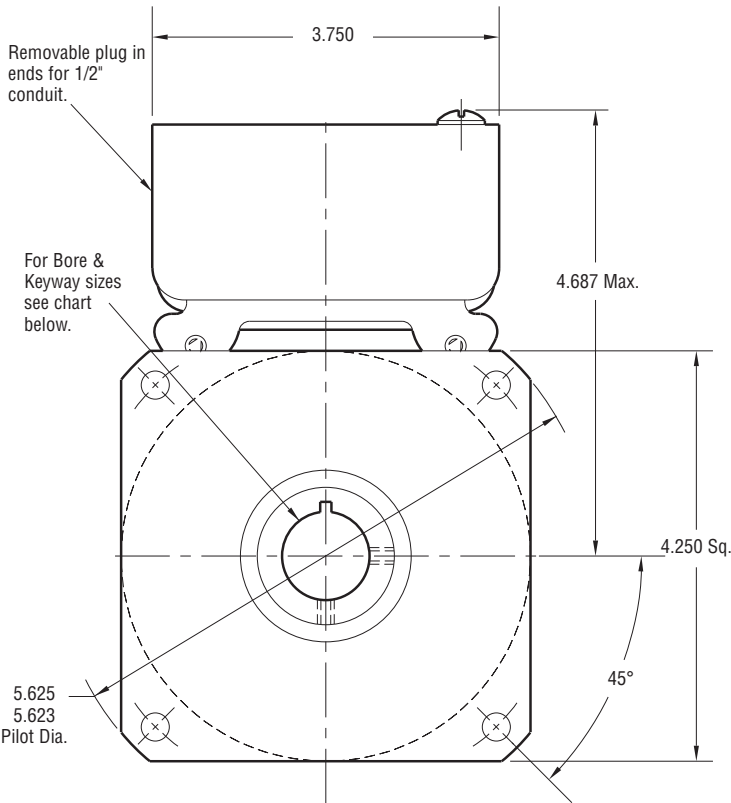

.296/.280 dia. (4) holes equally spaced on 5.000 dia. Mounting holes are within .010 of true position relative to pilot diameter.

**FIELD VIEW**

**Customer Shall Maintain:**

1. Squareness of field mounting face with shaft within .003 T.I.R. measured at pilot diameter.
2. Concentricity of field mounting pilot diameter with rotor mounting shaft within .003 T.I.R.
- \*3. Customer shall maintain dimension as noted.

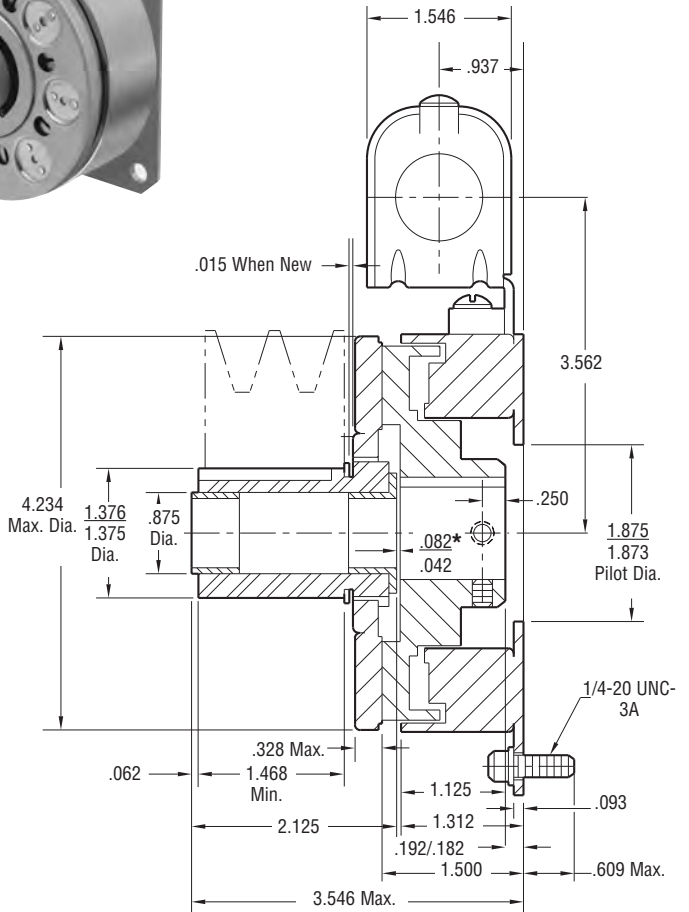

**Bore and Keyway Dimensions**

Armature Bore Dia.	Keyway	Rotor Bore Dia.	Keyway
.5000/.4995	.312 x .156	.501/.500	.125 x .062
.6250/.6245	x 1.25	.626/.625	
.7500/.7495		.751/.750	.187 x .093

Static Torque	270 lb.in.
Maximum Speed	4,500 rpm
Standard Voltage	D.C. 6, 24, 90

All dimensions are nominal unless otherwise noted.

Information on inertia and weights begins on page 239. Coil data is on pages 250 and 251.



SF-400 Flange Mounted

Drawing I-25695

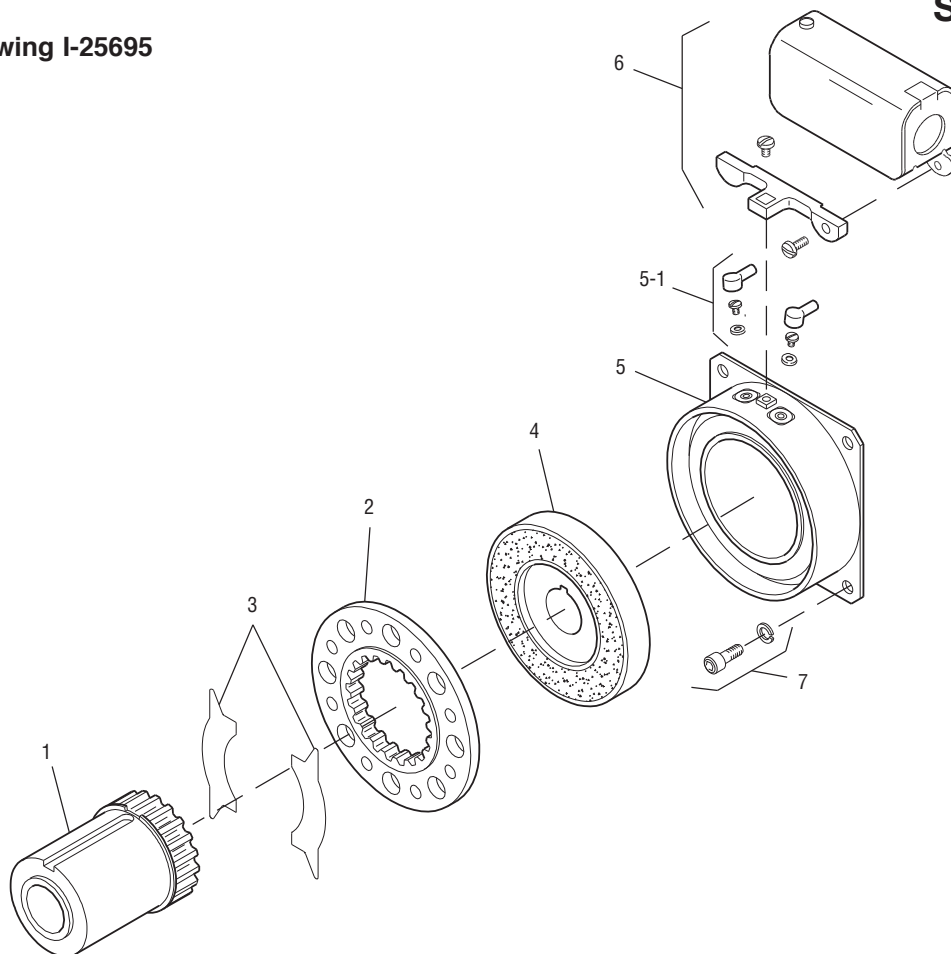

Item	Description	Part Number	Qty.
1	Armature Hub		1
	1/2" Bore	5125-541-002	
	5/8" Bore	5125-541-003	
	3/4" Bore	5125-541-004	
2	Armature	5125-111-001	1
3	Release Spring	5104-101-003	1
4	Rotor		1
	1/2" Bore	5104-751-033	
	5/8" Bore	5104-751-034	
	3/4" Bore	5104-751-035	
	7/8" Bore	5104-751-036	
	1" Bore	5104-751-037	
5	Field		1
	6 Volt	5104-451-032	
	24 Volt	5104-451-033	
	90 Volt	5104-451-034	
5-1	Terminal Accessory	5103-101-002	1
6	Conduit Box	5200-101-010	1
7	Mounting Accessory	5104-101-002	1

**How to Order:**

1. Specify Bore Size for Items 1 and 4.
2. Specify Voltage for Item 5.
3. See Controls Section.

**Example:**

SF-400 Clutch per I-25695 - 90 Volt  
 3/4" Armature Hub Bore  
 3/4" Rotor Bore

These units, when used in conjunction with the correct Warner Electric conduit box, meet the standards set of UL508 and are listed under guide card #NMTR2, file #59164.

These units are CSA certified under file #LR11543

Refer to Service Manual P-200.

# Clutch

## SF-400 Bearing Mounted



For Bore & Keyway sizes see chart below.

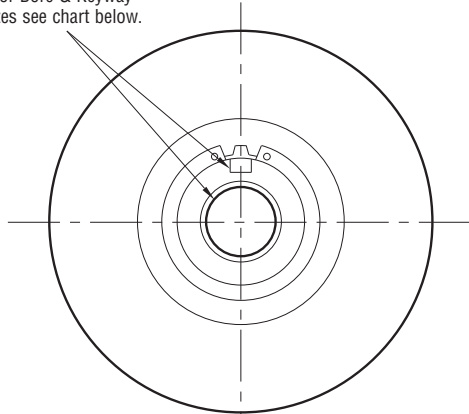

**ARMATURE VIEW**

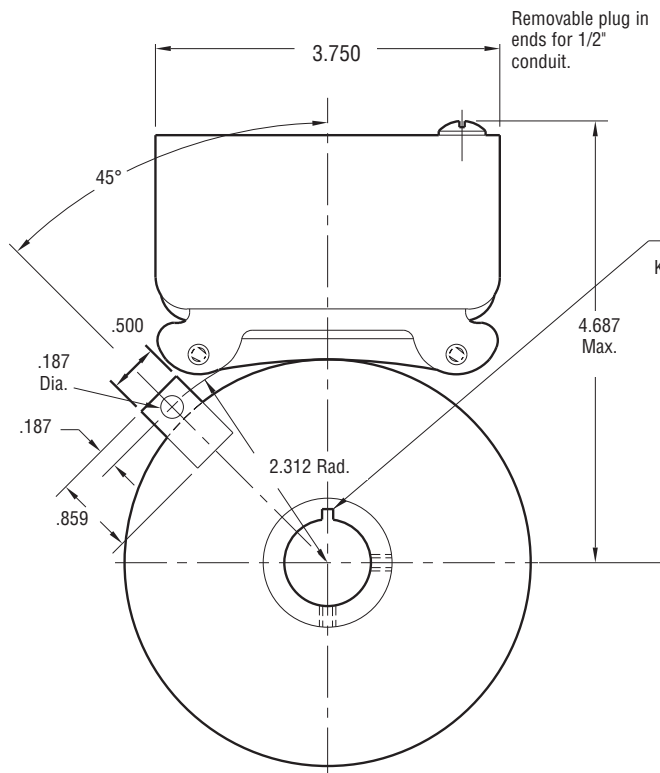

**FIELD VIEW**

Removable plug in ends for 1/2" conduit.

For Bore & Keyway sizes see chart below.

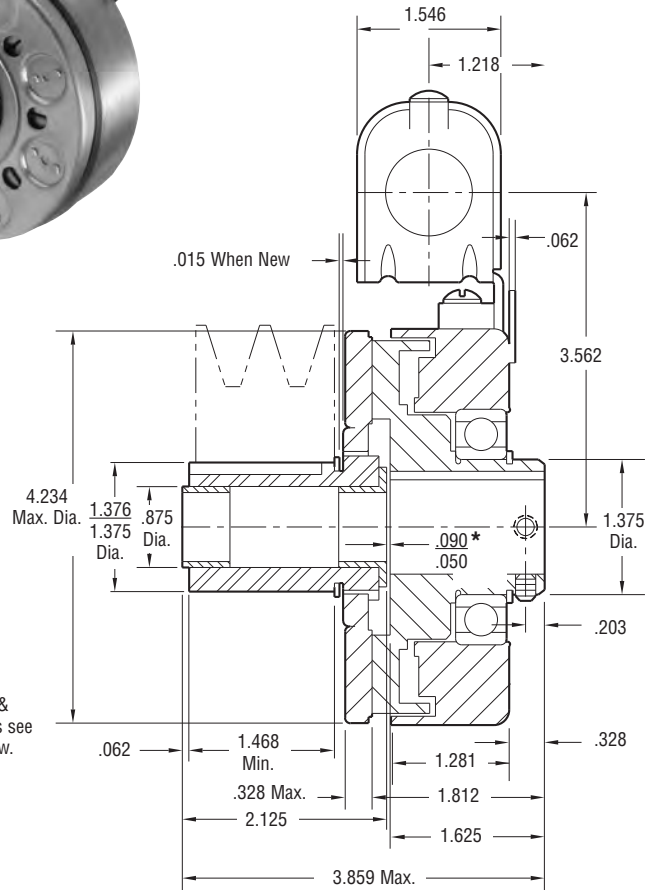

### Bore and Keyway Dimensions

Armature Bore Dia.	Keyway	Rotor Bore Dia.	Keyway
.5000/.4995	.312 x .156 x 1.25	.501/.500	.125 x .062
.6250/.6245		.626/.625	.187 x .093
.7500/.7495		.751/.750	
		.876/.875	
		1.001/1.000	

Static Torque	270 lb.in.
Maximum Speed	4,500 rpm
Standard Voltage	D.C. 6, 24, 90

All dimensions are nominal unless otherwise noted.

Information on inertia and weights begins on page 239. Coil data is on pages 250 and 251.

\*Customer shall maintain dimension as noted.



SF-400 Bearing Mounted

Drawing I-25696

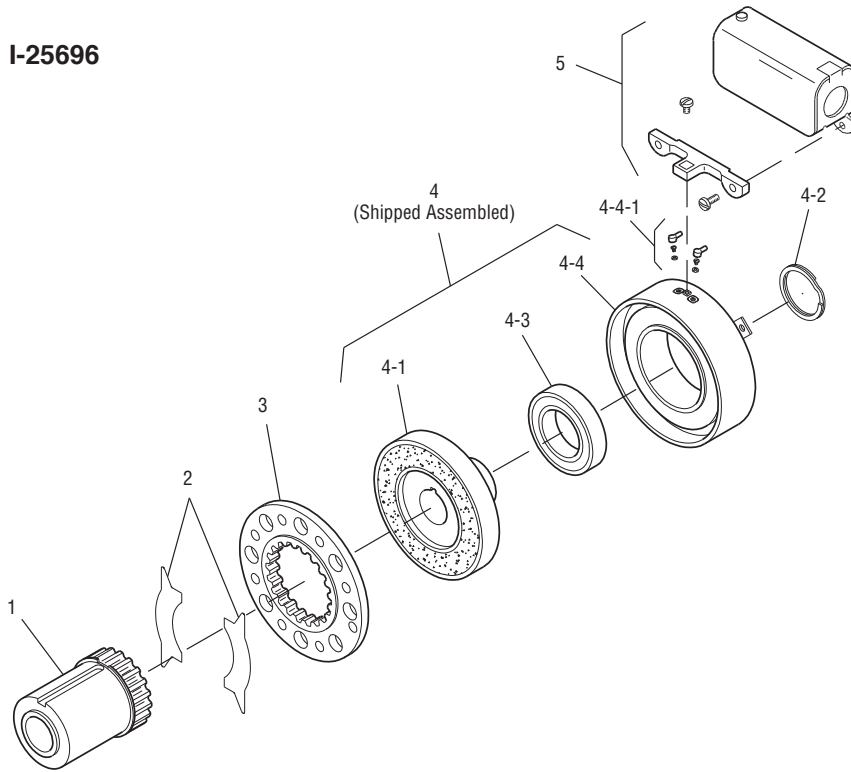

Item	Description	Part Number	Qty.
1	Armature Hub		1
	1/2" Bore	5125-541-002	
	5/8" Bore	5125-541-003	
	3/4" Bore	5125-541-004	
2	Release Spring Optional	5104-101-003	1
3	Armature	5125-111-001	1
4	Field and Rotor Assembly		1
	6 Volt – 1/2" Bore	5104-452-052	
	24 Volt – 1/2" Bore	5104-452-053	
	90 Volt – 1/2" Bore	5104-452-054	
	6 Volt – 5/8" Bore	5104-452-055	
	24 Volt – 5/8" Bore	5104-452-056	
	90 Volt – 5/8" Bore	5104-452-057	
	6 Volt – 3/4" Bore	5104-452-058	
	24 Volt – 3/4" Bore	5104-452-059	
	90 Volt – 3/4" Bore	5104-452-060	
	6 Volt – 7/8" Bore	5104-452-061	
	24 Volt – 7/8" Bore	5104-452-062	
90 Volt – 7/8" Bore	5104-452-063		
6 Volt – 1" Bore	5104-452-064		
24 Volt – 1" Bore	5104-452-065		
90 Volt – 1" Bore	5104-452-066		
4-1	Rotor		1
	1/2" Bore	5104-751-043	

Item	Description	Part Number	Qty.
	5/8" Bore	5104-751-044	
	3/4" Bore	5104-751-045	
	7/8" Bore	5104-741-046	
	1" Bore	5104-741-047	
4-2	Retainer Ring	748-0018	1
4-3	Ball Bearing	166-0150	1
4-4	Field		1
	6 Volt	5104-451-038	
	24 Volt	5104-451-039	
	90 Volt	5104-451-040	
4-4-1	Terminal Accessory	5103-101-002	1
5	Conduit Box	5200-101-010	1

**How to Order:**

1. Specify Bore Size for Items 1 and 4.
2. Specify Voltage for Item 4.
3. See Controls Section.

**Example:**

SF-400 Clutch per I-25696 - 90 Volt  
 3/4" Armature Hub Bore  
 3/4" Rotor Bore

These units, when used in conjunction with the correct Warner Electric conduit box, meet standards set forth in UL508 and are listed under guide card #NMTR2, file #59164.

These units are CSA certified under file #LR11543

Service Manual P-200.

# Clutch

## SF-500 Bearing Mounted

See page 230 for details on Drive Pin mountings.

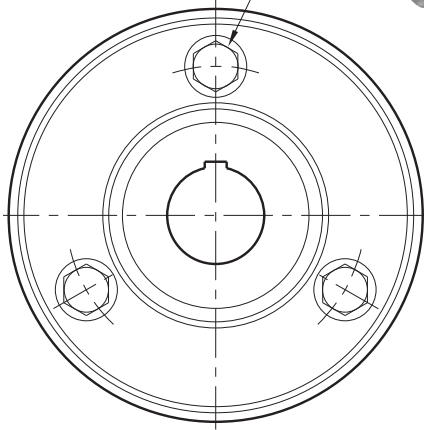

**ARMATURE VIEW**

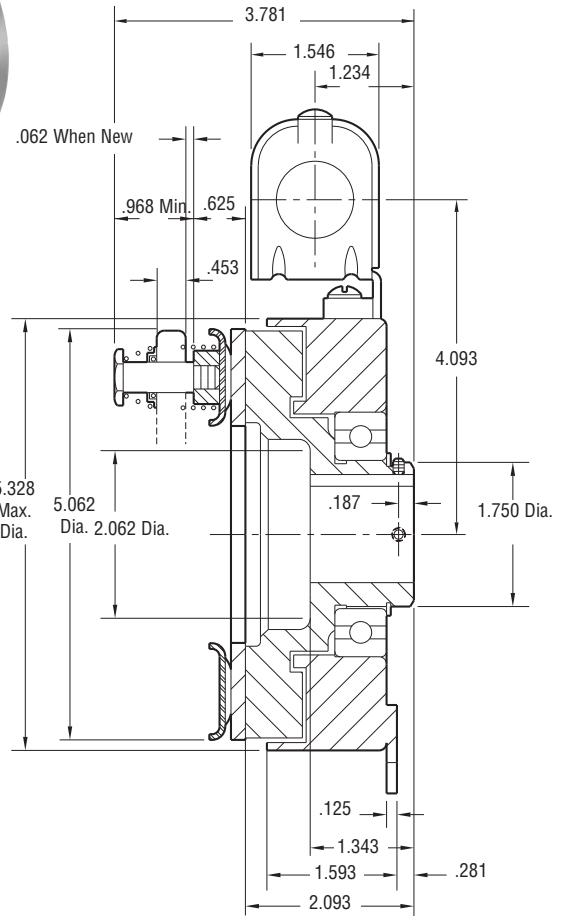

Removable plug in ends for 1/2" conduit.

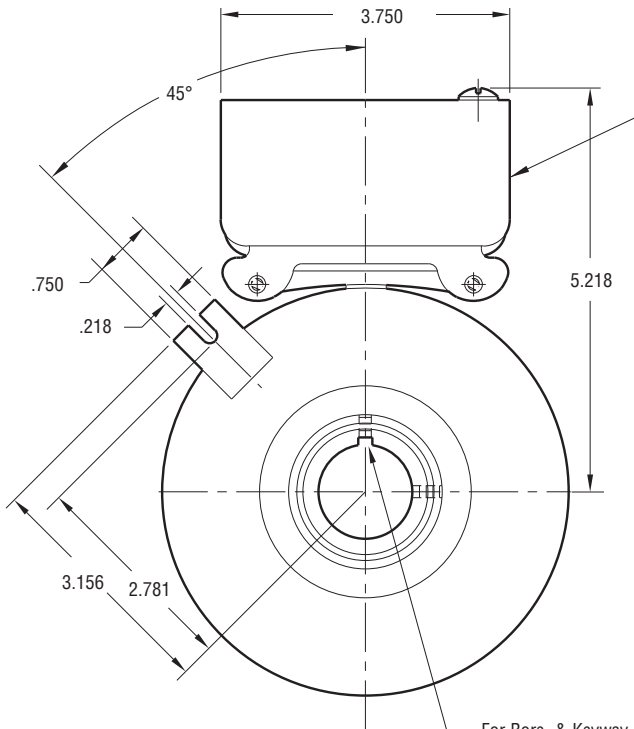

For Bore & Keyway sizes see chart below.

**FIELD VIEW**

### Bore and Keyway Dimensions

Rotor Bore Dia.	Keyway
.751/.750	.187 x .093
.876/.875	
.9385/.9375	
1.001/1.000	.250 x .125
1.126/1.125	
1.251/1.250	

Static Torque	50 lb.ft.
Maximum Speed	4,000 rpm
Standard Voltage	D.C. 6, 24, 90

All dimensions are nominal unless otherwise noted.

Information on inertia and weights begins on page 239. Coil data is on pages 250 and 251.

### Customer Shall Maintain:

1. Armature shafts to be concentric with rotor mounting shaft within .006 T.I.R.





SF-500 Bearing Mounted

Drawing I-25715

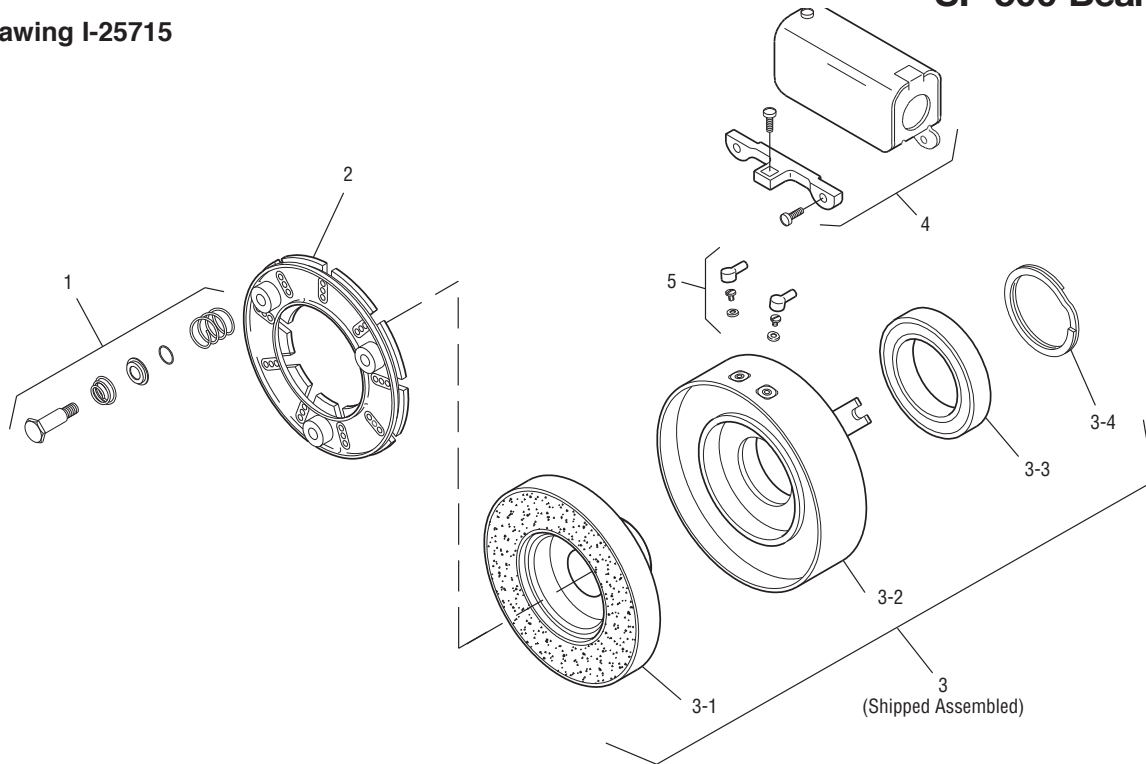

Item	Description	Part Number	Qty.
1	Autogap Accessory	5200-101-009	3
2	Armature	5300-111-002	1
3	Field and Rotor Assembly		1
	6 Volt – 3/4" Bore	5200-452-002	
	24 Volt – 3/4" Bore	5200-452-004	
	90 Volt – 3/4" Bore	5200-452-005	
	6 Volt – 7/8" Bore	5200-452-008	
	24 Volt – 7/8" Bore	5200-452-010	
	90 Volt – 7/8" Bore	5200-452-011	
	24 Volt – 15/16" Bore	5200-452-016	
	90 Volt – 15/16" Bore	5200-452-017	
	6 Volt – 1" Bore	5200-452-020	
	24 Volt – 1" Bore	5200-452-022	
	90 Volt – 1" Bore	5200-452-023	
	6 Volt – 1-1/8" Bore	5200-452-026	
	24 Volt – 1-1/8" Bore	5200-452-028	
	90 Volt – 1-1/8" Bore	5200-452-029	
	6 Volt – 1-1/4" Bore	5200-452-032	
	24 Volt – 1-1/4" Bore	5200-452-034	
	90 Volt – 1-1/4" Bore	5200-452-035	
3-1	Rotor		1
	3/4" Bore	5200-751-002	
	7/8" Bore	5200-751-003	
	15/16" Bore	5200-741-004	

Item	Description	Part Number	Qty.
	1" Bore	5200-751-005	
	1-1/8" Bore	5200-751-006	
	1-1/4" Bore	5200-751-007	
3-2	Field & Bearing Assembly		1
	6 Volt	5200-451-024	
	24 Volt	5200-451-026	
	90 Volt	5200-451-027	
3-3	Ball Bearing	166-0110	1
3-4	Retainer Ring	748-0002	1
4	Conduit Box	5200-101-010	1
5	Terminal Accessory	5311-101-001	1

**How to Order:**

1. Specify Bore Size for Item 3.
2. Specify Voltage for Item 3.
3. See Controls Section.

**Example:**

SF-500 Clutch per I-25715 - 90 Volt  
3/4" Bore

These units meet standards set forth in UL508 and are listed under guide card #NMTR2, file #59164.

These units are CSA certified under file #LR11543.

Refer to Service Manual P-202.

# Clutch

## SF-650 Flange Mounted



See page 230 for details on Drive Pin mountings.

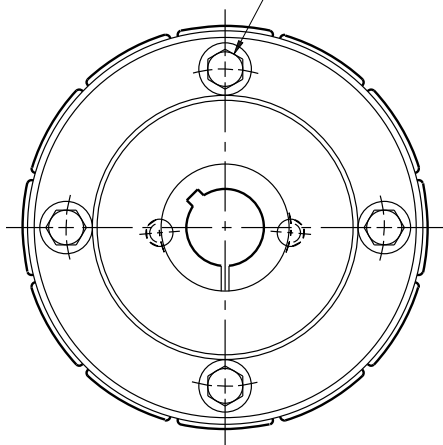

**ARMATURE VIEW**

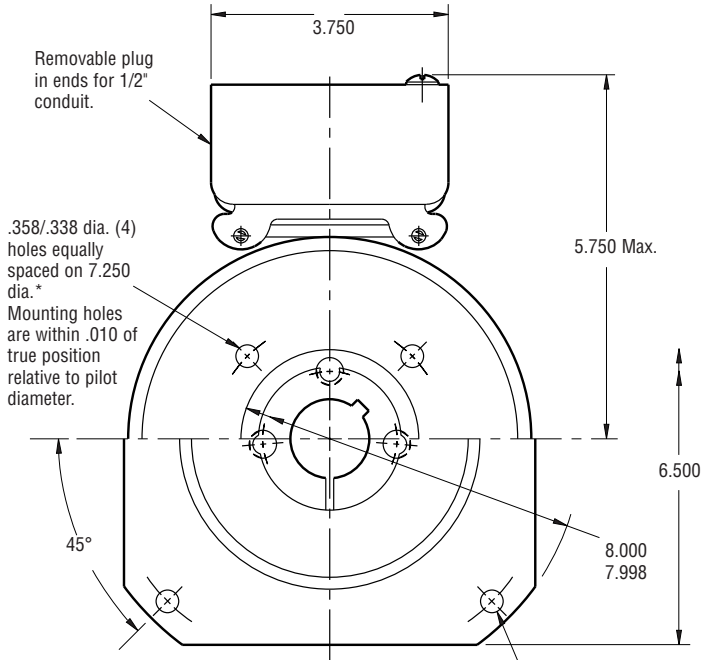

**FIELD VIEW**

(Inside & Outside Mounted)

.358/.338 dia. (4) holes equally spaced on 7.250 dia.\*

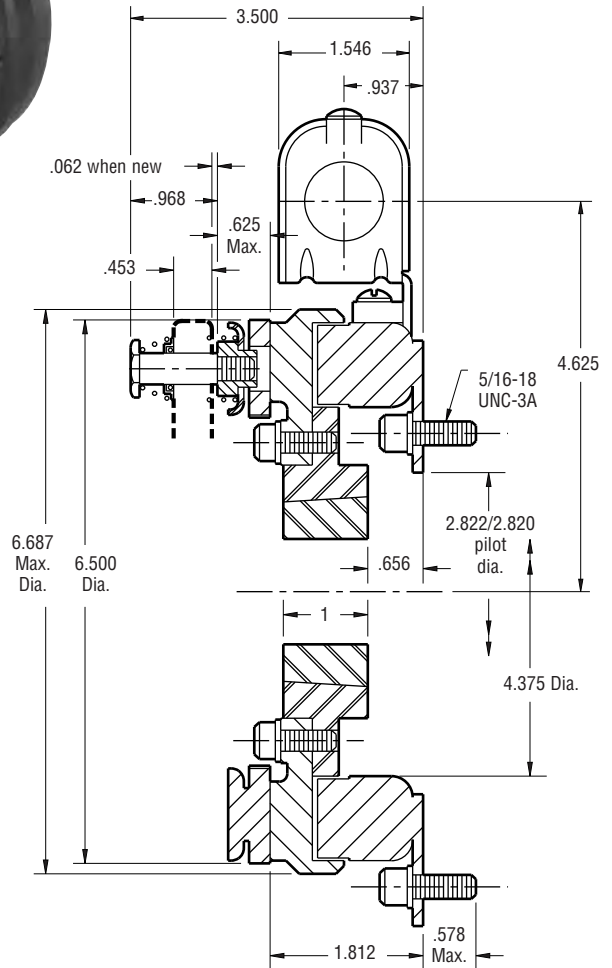

Shaft Size	.500 – 1.625
Static Torque	95 lb.ft.
Maximum Speed	3,600 rpm
Standard Voltage	D.C. 6, 24, 90

All dimensions are nominal unless otherwise noted.

Information on inertia and weights begins on page 239. Coil data is on pages 250 and 251.

### Customer Shall Maintain:

1. Concentricity of field mounting pilot diameter with rotor mounting shaft within .006 T.I.R.
2. Squareness of field mounting face with shaft within .006 T.I.R. measured at field mounting bolt circle.
3. Rotor mounting pilot diameter must be concentric with shaft within .006 T.I.R.



## SF-650 Flange Mounted

Drawing I-25749

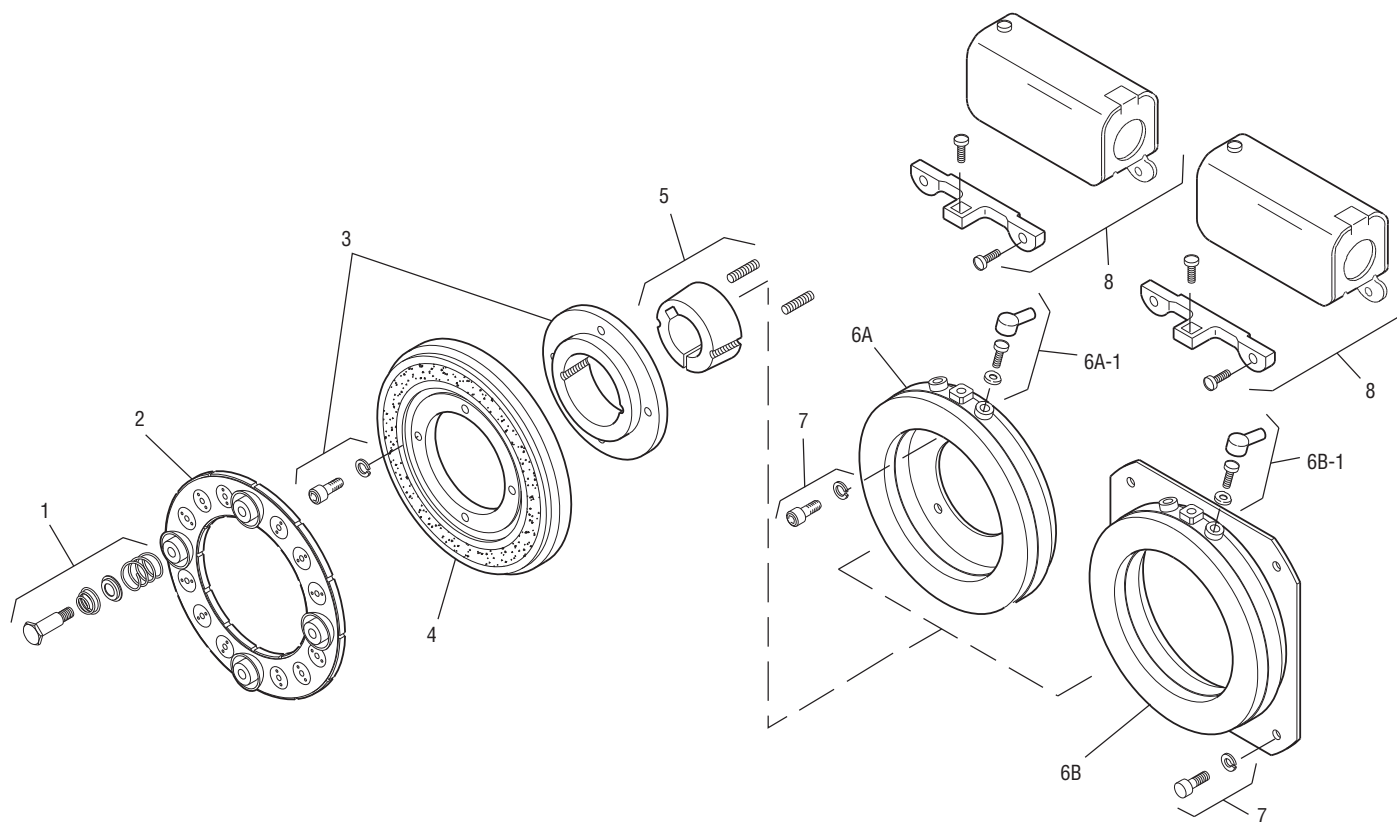

Item	Description	Part Number	Qty.
1	Armature Accessory	5181-101-010	4
2	Armature	5281-111-002	1
3	Rotor Hub & Mounting Acc.	5207-101-005	1
4	Rotor	5281-751-001	1
5	Bushing*		1
	1/2" to 1-5/8" Bore	180-0326 to 180-0344	
6A	Field - Inside Mounted		1
	6 Volt	5207-451-009	
	24 Volt	5207-451-012	
	90 Volt	5207-451-011	
6A-1	Terminal Accessory	5311-101-001	1
6B	Field - Outside Mounted		1
	6 Volt	5207-451-003	
	24 Volt	5207-451-006	
	90 Volt	5207-451-005	
6B-1	Terminal Accessory	5311-101-001	1
7	Mounting Accessory	5321-101-002	1
8	Conduit Box	5200-101-010	1

### How to Order:

1. Specify Bore Size for Item 5.
2. Specify Voltage for Item 6.
3. Specify Inside or Outside Mounted for Item 6.
4. See Controls Section.

### Example:

SF-650 Clutch per I-25749 - 90 Volt  
1" Bore

These units, when used in conjunction with the correct Warner Electric conduit box, meet the standards of UL508 and are listed under guide card #NMTR, file #59164.

These units are CSA certified under file #LR11543

\*See page 252 for specific part numbers.

Refer to Service Manual P-202.

# Clutch

## SF-650 Bearing Mounted



See page 230 for details on Drive Pin mountings.

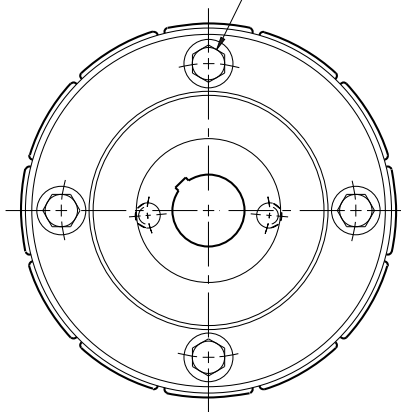

**ARMATURE VIEW**

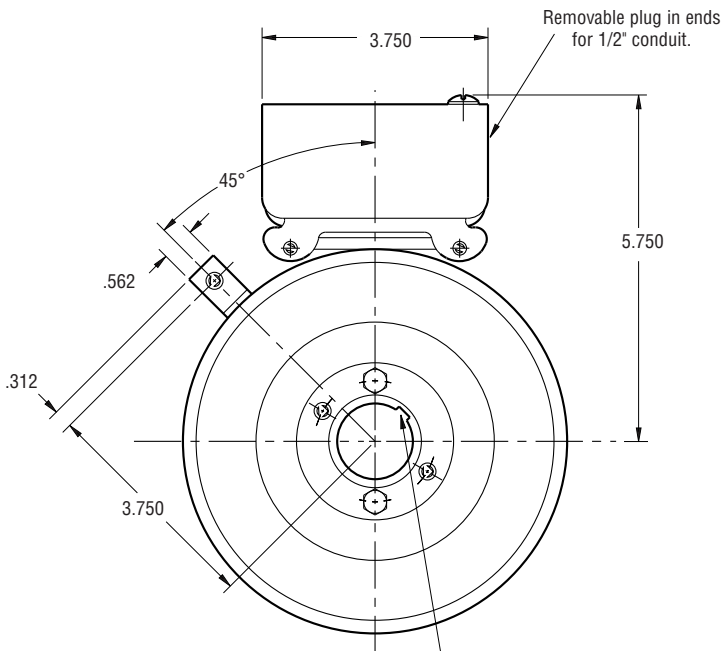

See page 252 for details on Bushings.

**FIELD VIEW**

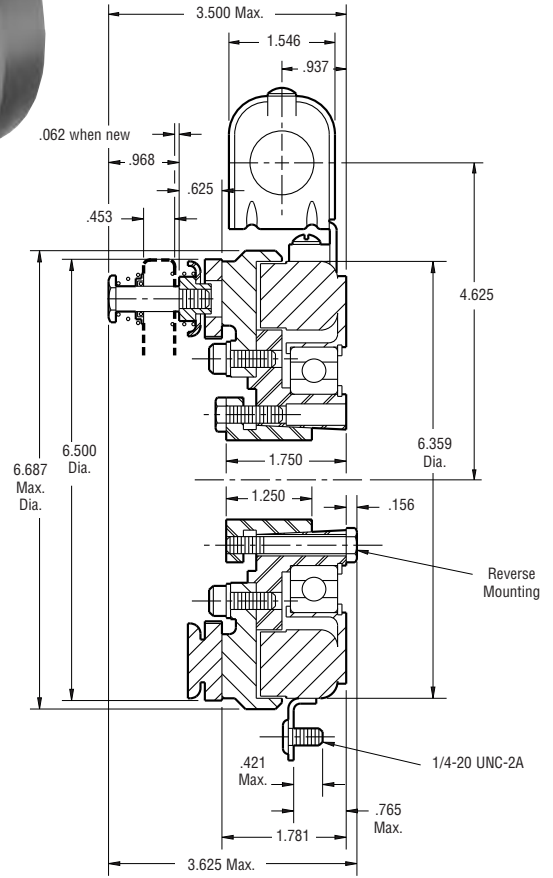

Shaft Size	.500 – 1.500
Static Torque	95 lb.ft.
Maximum Speed	3,600 rpm
Standard Voltage	D.C. 6, 24, 90

All dimensions are nominal unless otherwise noted.

Information on inertia and weights begins on page 239. Coil data is on pages 250 and 251.



SF-650 Bearing Mounted

Drawing I-25750

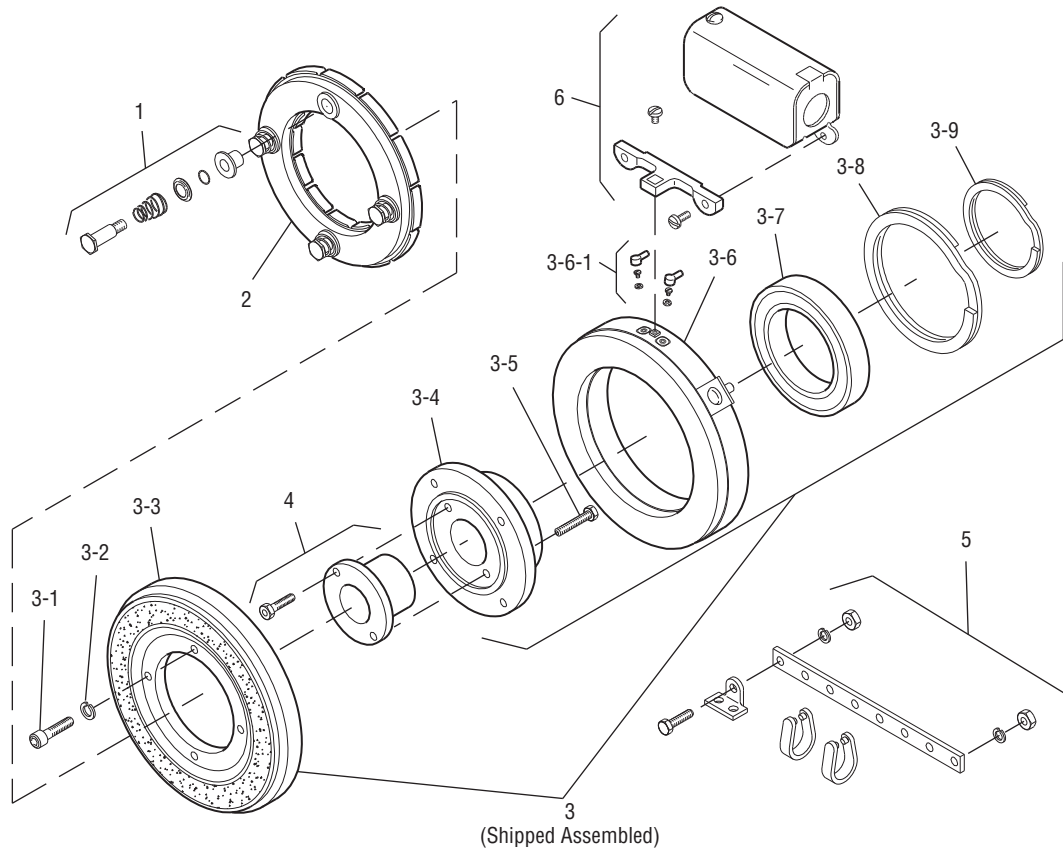

Item	Description	Part Number	Qty.
1	Autogap Accessory	5181-101-010	4
2	Armature	5281-111-002	1
3	Field and Rotor Assembly		1
	6 Volt	5207-452-002	
	24 Volt	5207-452-005	
	90 Volt	5207-452-004	
3-1	Capscrew	797-0083	4
3-2	Lockwasher	950-0355	4
3-3	Rotor Assembly	5281-751-001	1
3-4	Rotor Hub	540-0614	1
3-5	Reverse Mounting Accessory	5201-101-005	1
3-6	Field		1
	6 Volt	5281-451-002	
	24 Volt	5281-451-004	
	90 Volt	5281-451-005	
3-6-1	Terminal Accessory	5311-101-001	1
3-7	Ball Bearing	166-0104	1
3-8	Retainer Ring - External	748-0004	1
3-9	Retainer Ring -Internal	748-0104	1

Item	Description	Part Number	Qty.
4	Bushing*		1
	1/2" to 1-1/2" Bore	180-0002 to 180-0018	
†5	Torque Arm Accessory	5207-101-003	1
6	Conduit Box	5200-101-010	1

**How to Order:**

1. Specify Voltage for Item 3.
2. Specify Bore Size for Item 4.
3. See Controls Section.

**Example:**

SF-650 Clutch, bearing mounted per I-25750 - 90 Volt, 1" Bore

These units, when used in conjunction with the correct Warner Electric conduit box, meet the standards of UL508 and are listed under guide card #NMTR, file #59164.

These units are CSA certified under file #LR11543

\*See page 252 for specific part numbers.

Refer to Service Manual P-202.

†Optional – not included in price.

# Clutch-Normal Duty

## SF-825 Flange Mounted



See page 230 for Drive Pin mountings.

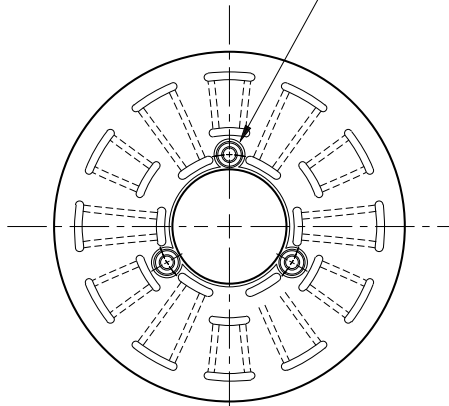

**ARMATURE VIEW**

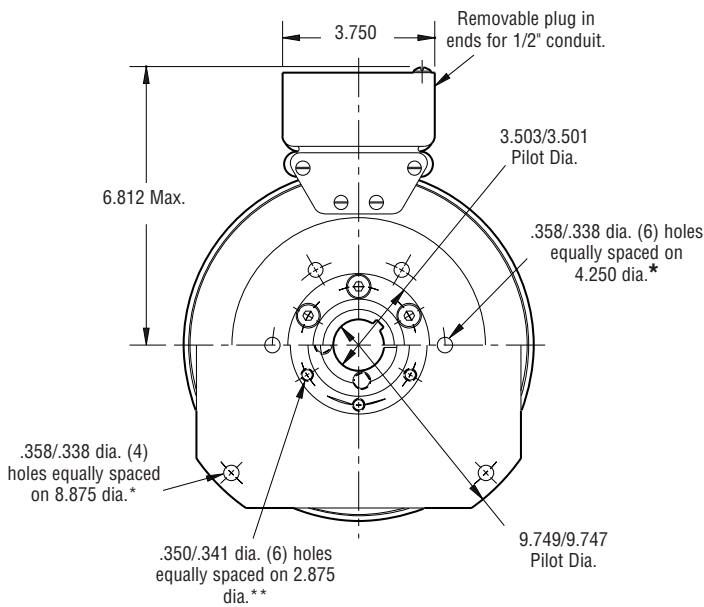

**FIELD VIEW**

(Inside & Outside Mounted)

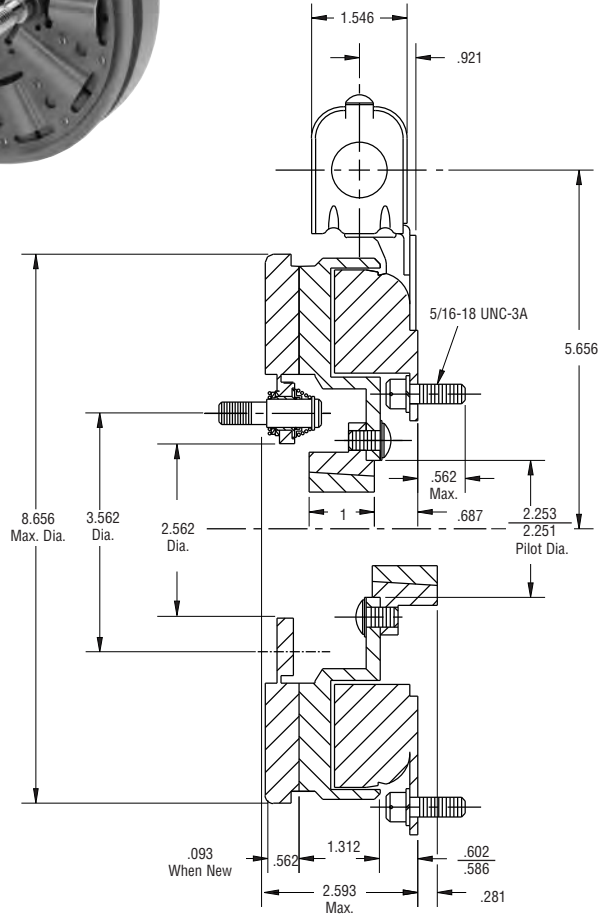

\* Mounting holes are within .010 of true position relative to pilot diameter.

\*\* Mounting holes are within .008 of true position relative to pilot diameter.

### Customer Shall Maintain:

1. Concentricity of field mounting pilot diameter with rotor mounting shaft within .006 T.I.R.
2. Squareness of field mounting face with shaft within .006 T.I.R. measured at field mounting bolt circle.

Shaft Size	.500 – 1.250
Static Torque	125 lb.ft.
Maximum Speed	4,000 rpm
Standard Voltage	D.C. 6, 24, 90

All dimensions are nominal unless otherwise noted.

Information on inertia and weights begins on page 239. Coil data is on pages 250 and 251.



SF-825 Flange Mounted

Drawing I-25560

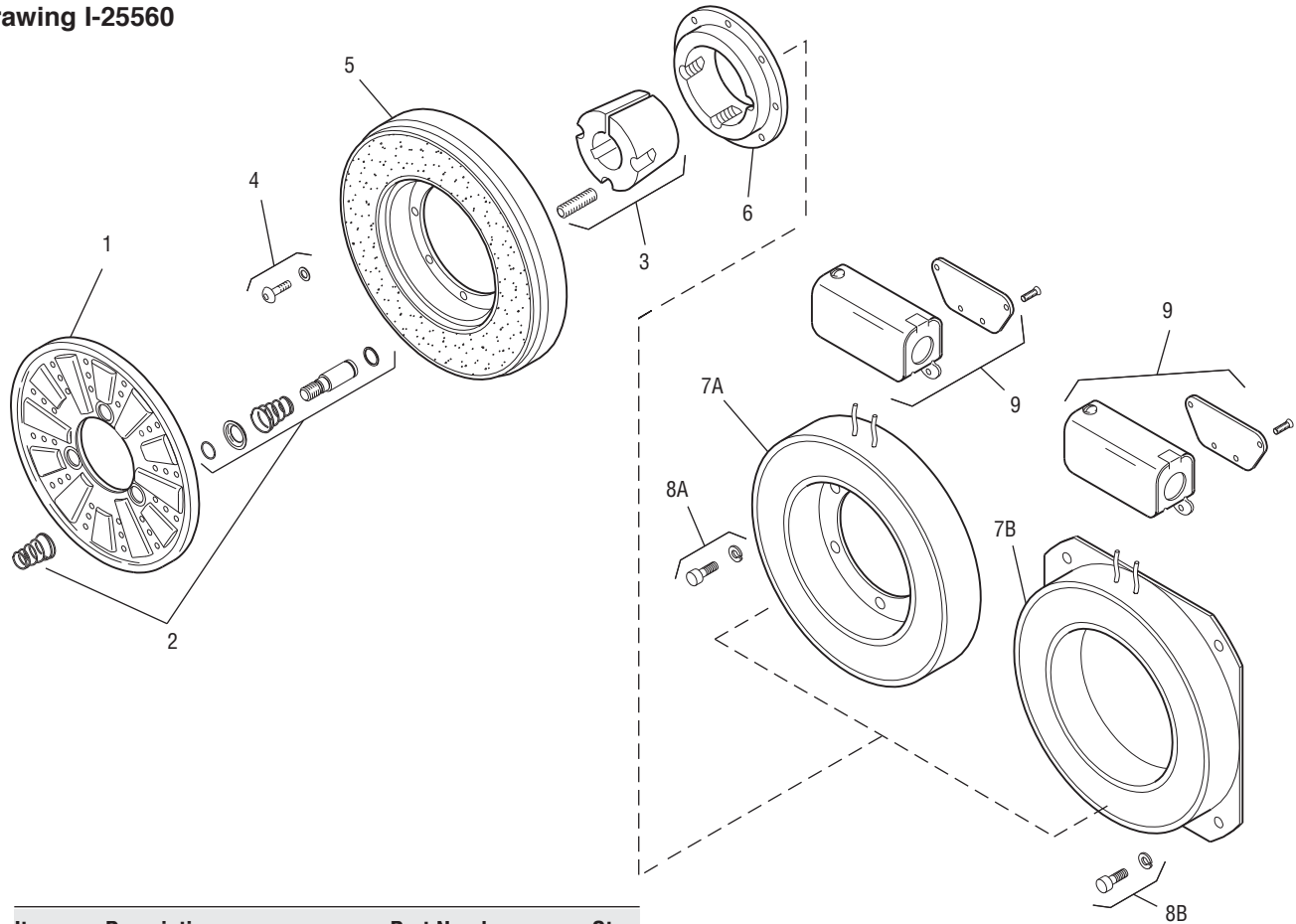

Item	Description	Part Number	Qty.
1	Armature	5301-111-018	1
2	Autogap Accessory	5201-101-008	3
3	Bushing*		1
	1/2" to 1-1/4" Bore	180-0101 to 180-0113	
4	Mounting Accessory	5201-101-007	1
5	Rotor		1
	Standard Friction Material	5201-751-003	
	†Optional LK Facing	5201-751-007	
6	Rotor Hub	540-0013	1
7A	Field - Inside Mounted		1
	6 Volt	5201-451-006	
	24 Volt	5201-451-008	
	90 Volt	5201-451-010	
7B	Field - Outside Mounted		1
	6 Volt	5201-451-014	
	24 Volt	5201-451-016	
	90 Volt	5201-451-018	
8A	Mounting Accessory - I.M.	5321-101-001	1
8B	Mounting Accessory - O.M.	5321-101-002	1
9	Conduit Box	5200-101-012	1

**How to Order:**

1. Specify Bore Size for Item 3.
2. Specify Voltage for Items 7A or 7B.
3. Specify Inside Mounted for Items 7A and 8A or Outside Mounted for Items 7B and 8B.
4. See Controls Section.

**Example:**

SF-825 Clutch per I-25560 -90 Volt, 1" Bore, Inside Mounted

These units, when used in conjunction with the correct Warner Electric conduit box, meet the standards of UL508 and are listed under guide card #NMTR, file #59164.

These units are CSA certified under file #LR11543.

\*See page 252 for specific part numbers.

Refer to Service Manual P-222.

†Optional LK facing available. For more information, see page 232.

## SF-825 Bearing Mounted

See page 230 for details on Drive Pin Mountings.

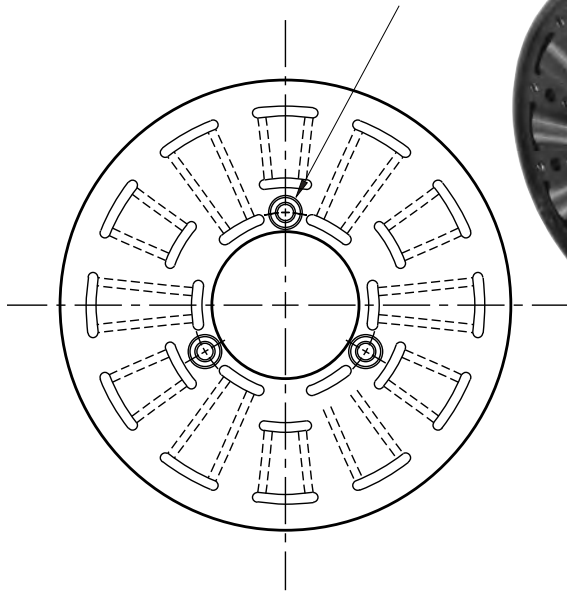

**ARMATURE VIEW**

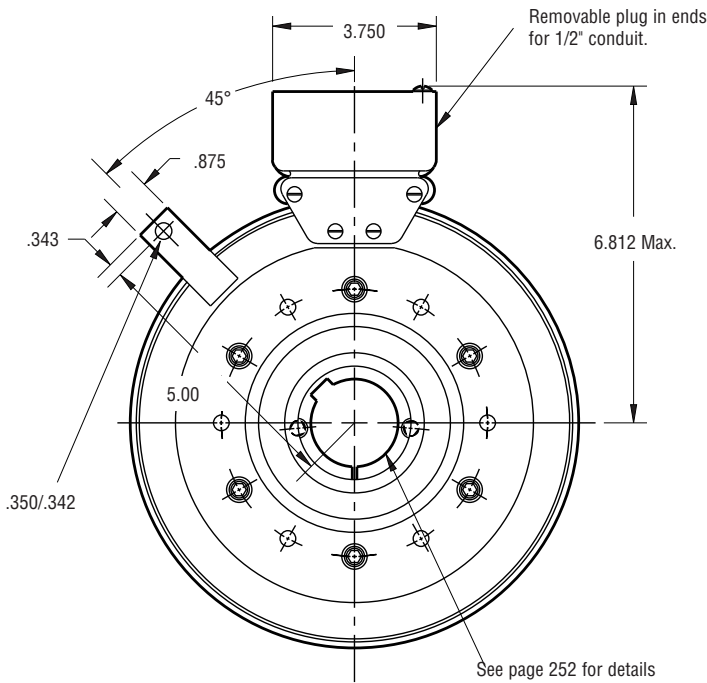
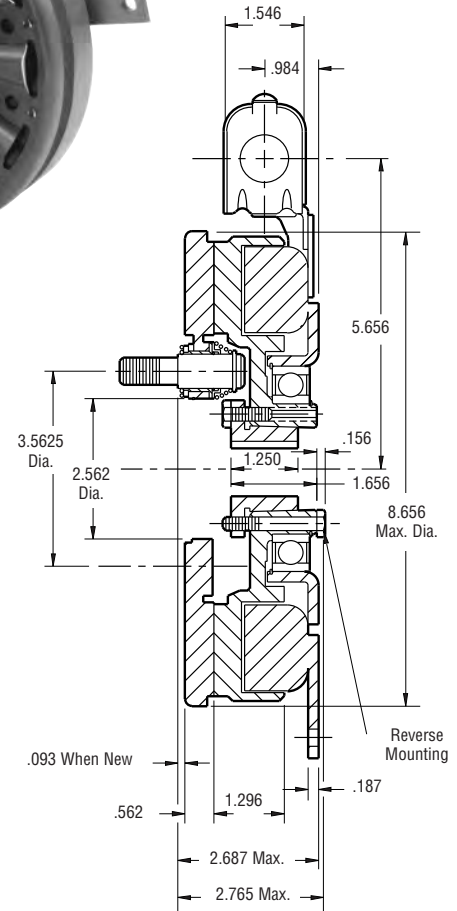

**FIELD VIEW**

See page 252 for details on Bushings.

Shaft Size	.500 – 1.500
Static Torque	150 lb.ft.
Maximum Speed	3,600 rpm
Standard Voltage	D.C. 6, 24, 90

All dimensions are nominal unless otherwise noted.

Information on inertia and weights begins on page 239. Coil data is on pages 250 and 251.





## SF-825 Bearing Mounted

Drawing I-25575

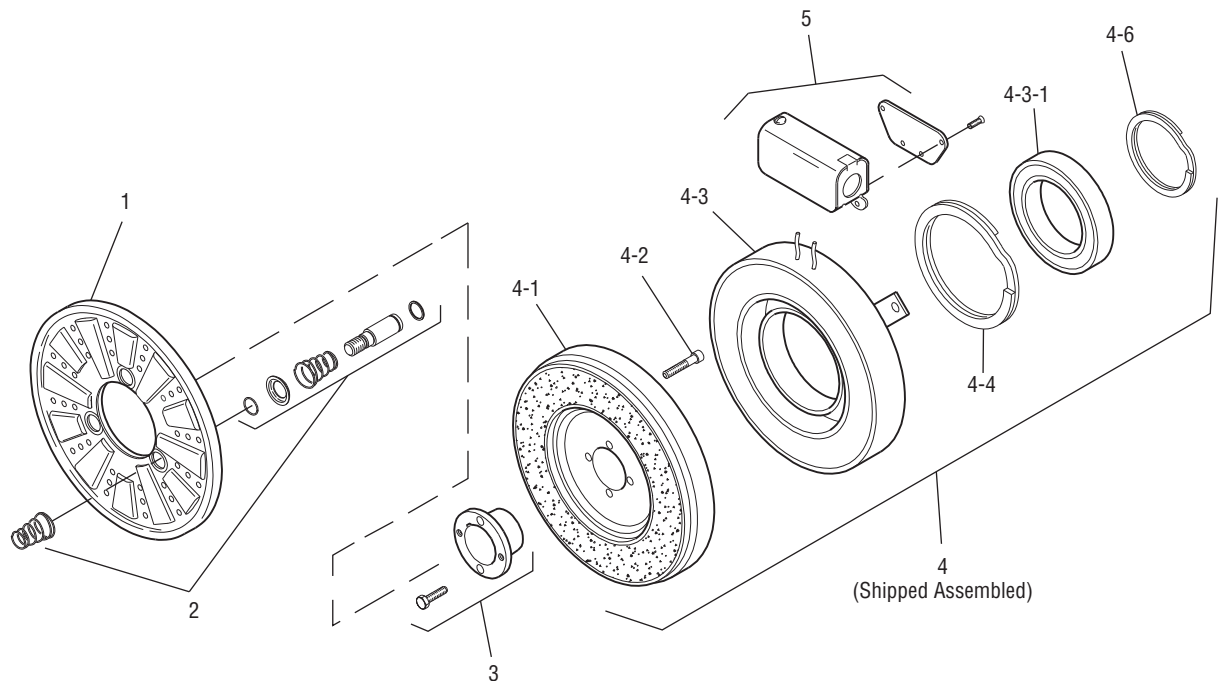

Item	Description	Part Number	Qty.
1	Armature	5301-111-018	1
2	Autogap Accessory	5201-101-008	3
3	Bushing*		1
	1/2" to 1-1/2" Bore	180-0002 to 180-0018	
4	Field & Rotor Assembly		1
	6 Volt	5201-452-002	
	24 Volt	5201-452-004	
	90 Volt	5201-452-006	
4-1	Rotor		1
	Standard Friction Material	5201-751-008	
4-2	Mounting Accessory	5201-101-005	1
4-3	Field & Bearing Assembly		1
	6 Volt	5201-451-054	
	24 Volt	5201-451-056	
	90 Volt	5201-451-057	
4-3-1	Ball Bearing	166-0142	1
4-4	Retainer Ring	748-0111	1
4-6	Retainer Ring	748-0016	1
5	Conduit Box	5200-101-012	1

### How to Order:

1. Specify Bore Size for Item 3.
2. Specify Voltage for Item 4.
3. See Controls Section.

### Example:

SF-825 Clutch per I-25575 - 90 Volt, 1" Bore

These units, when used in conjunction with the correct Warner Electric conduit box, meet the standards of UL508 and are listed under guide card #NMTR, file #59164. These units are CSA certified under file #LR11543.

\*See page 252 for specific part numbers.

Refer to Service Manual P-215.

SF-825 Flange Mounted

.271/.263 dia. 5 holes (hub) equally spaced on 2.015 dia. Mounting holes are within .003 of true position relative to pilot dia.

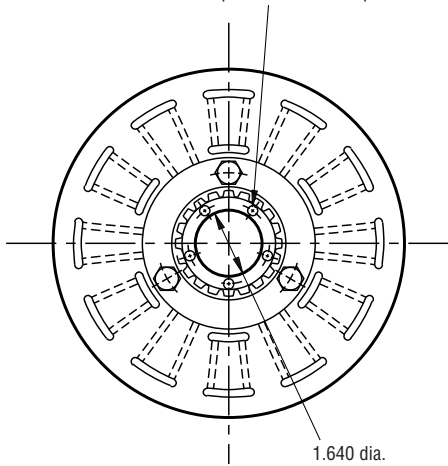

ARMATURE VIEW

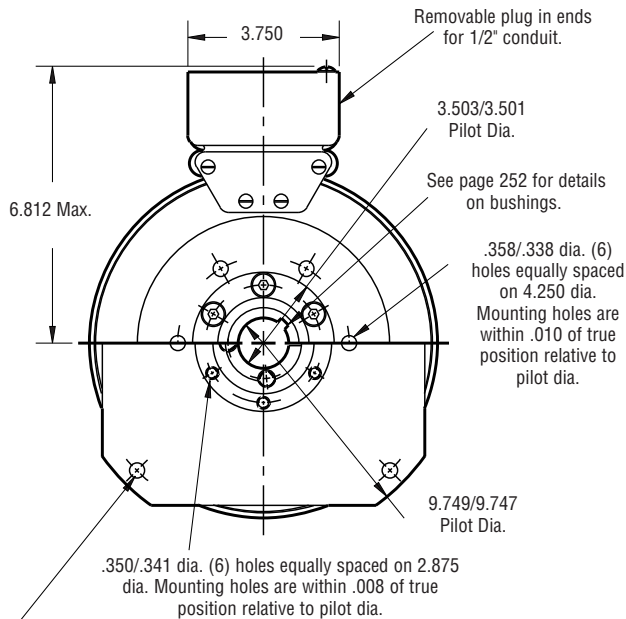

.358/.338 dia. (4) holes equally spaced on 8.875 dia. are within .010 of true position relative to pilot dia.

FIELD VIEW

(Inside & Outside Mounted)

Customer Shall Maintain:

1. Concentricity of field mounting pilot diameter with rotor mounting shaft within .006 T.I.R.
2. Squareness of field mounting face with shaft within .006 T.I.R. measured at field mounting bolt circle.
3. Rotor mounting shaft concentric with armature hub pilot diameter within .010 T.I.R.

When Hub is Furnished by Customer:

Rotor mounting pilot diameter must be concentric with rotor mounting shaft within .006 T.I.R.

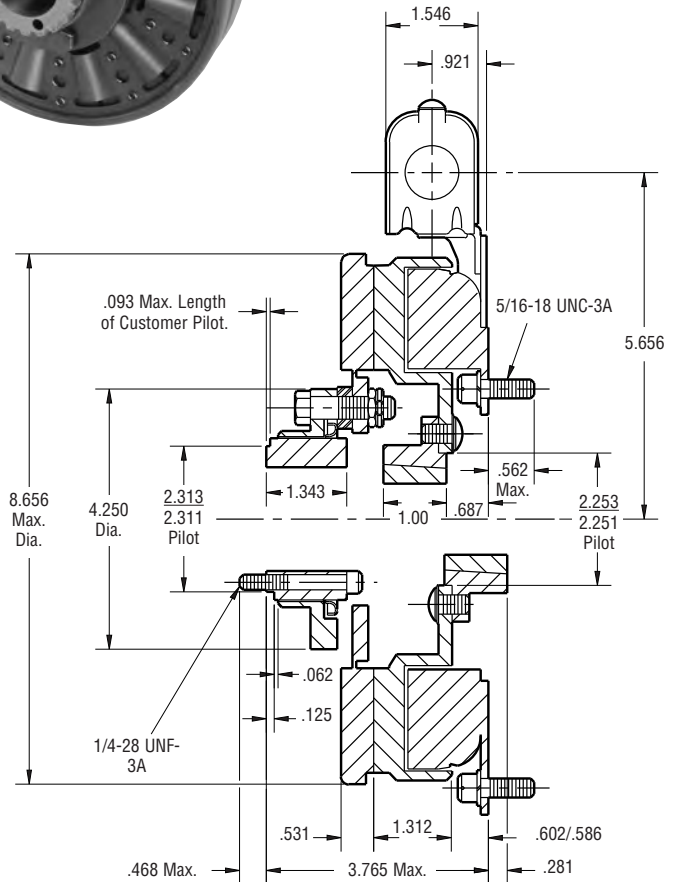

Shaft Size	.500 – 1.250
Static Torque	125 lb.ft.
Maximum Speed	4,000 rpm
Standard Voltage	D.C. 6, 24, 90

All dimensions are nominal unless otherwise noted.

Information on inertia and weights begins on page 239. Coil data is on pages 250 and 251.



## SF-825 Flange Mounted

Drawing I-25561

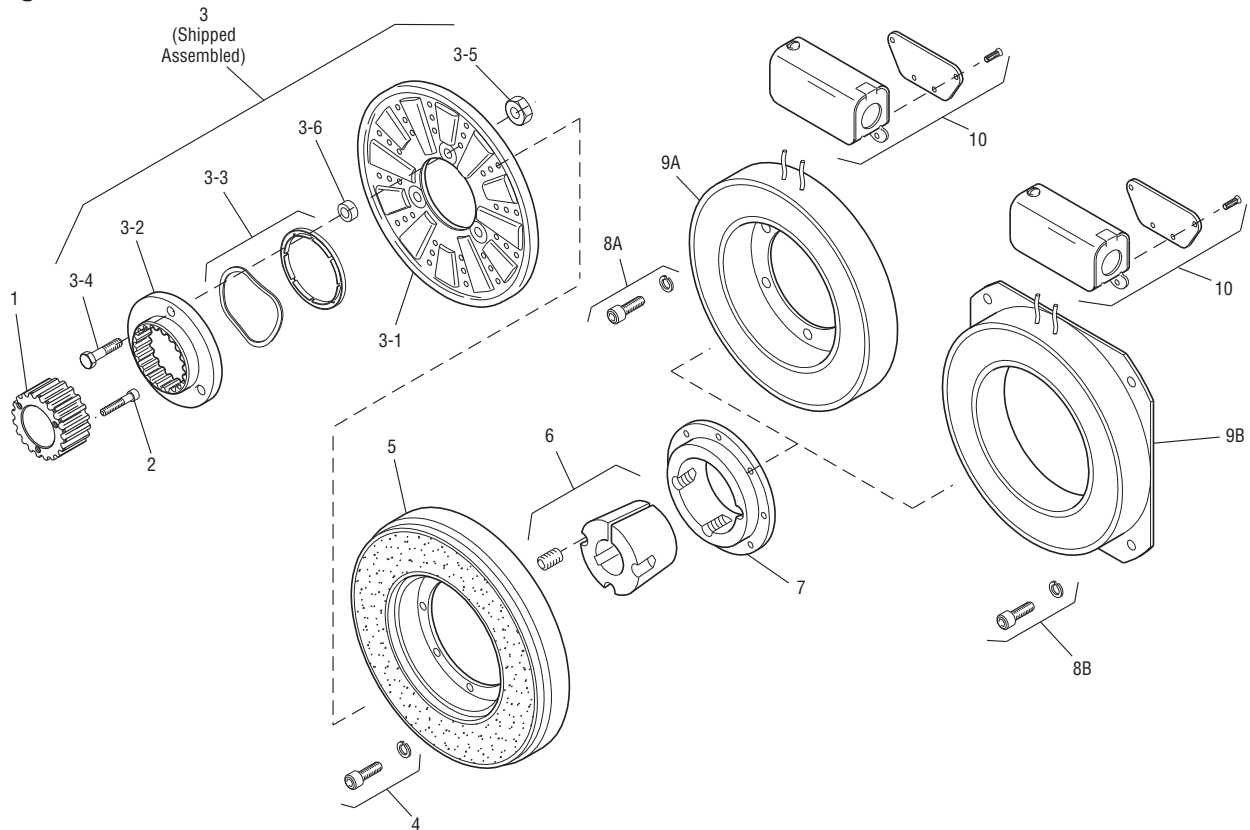

Item	Description	Part #	Qty.
1	Splined Hub	540-0146	1
2	Mounting Accessory	5201-101-001	1
3	Armature & Splined Adapter	5201-111-001	1
3-1	Armature	5321-111-022	1
3-2	Splined Adapter	104-0008	1
3-3	Autogap Accessory	5321-101-006	1
3-4	Screw	797-0341	3
3-5	Locknut	661-0004	3
3-6	Spacer	748-0333	3
4	Mounting Accessory	5201-101-007	1
5	Rotor		1
	Standard Friction Material	5201-751-003	
	†Optional LK Facing	5201-751-007	
6	Bushing, Taperlock*	180-0101 to 180-0113	1
7	Rotor Hub	540-0013	1
8A	Mounting Accessory, I.M.	5321-101-001	1
8B	Mounting Accessory, O.M.	5321-101-002	1
9A	Field, Inside Mounted		1
	6 Volt	5201-451-006	
	24 Volt	5201-451-008	
	90 Volt	5201-451-010	

Item	Description	Part #	Qty.
9B	Field, Outside Mounted		1
	6 Volt	5201-451-014	
	24 Volt	5201-451-016	
	90 Volt	5201-451-018	
10	Conduit Box	5200-101-012	1

### How to Order:

1. Specify Bore Size for Item 6.
2. Specify Voltage for Item 9A or 9B.
3. Specify Inside Mounted for Items 8A and 9A or Outside Mounted for Items 8B and 9B.
4. See Controls Section.

### Example:

SF-825 Clutch Coupling, Heavy Duty, per I-25561 - 90 Volt, Inside Mounted, 1" Bore (Item 6)

These units, when used in conjunction with the correct Warner Electric conduit box, meet the standards of UL508 and are listed under guide card #NMTR, file #59164. These units are CSA certified under file #LR11543

\*See page 252 for specific part numbers.

Refer to Service Manual P-215.

†Optional LK facing available. For more information, see page 232.

## SF-825 Bearing Mounted

.271/.263 dia. 5 holes (hub) equally spaced on 2.015 dia. and within .003 of true position relation to 2.313/2.311 pilot dia.

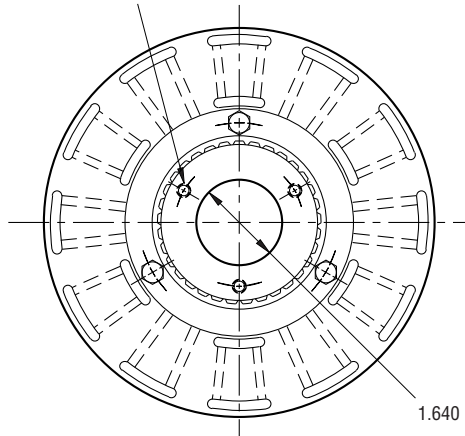

**ARMATURE VIEW**

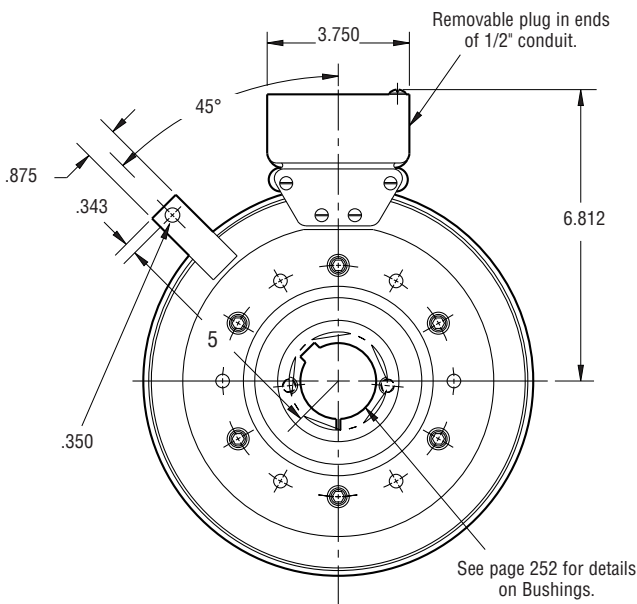

**FIELD VIEW**

See page 252 for details on Bushings.

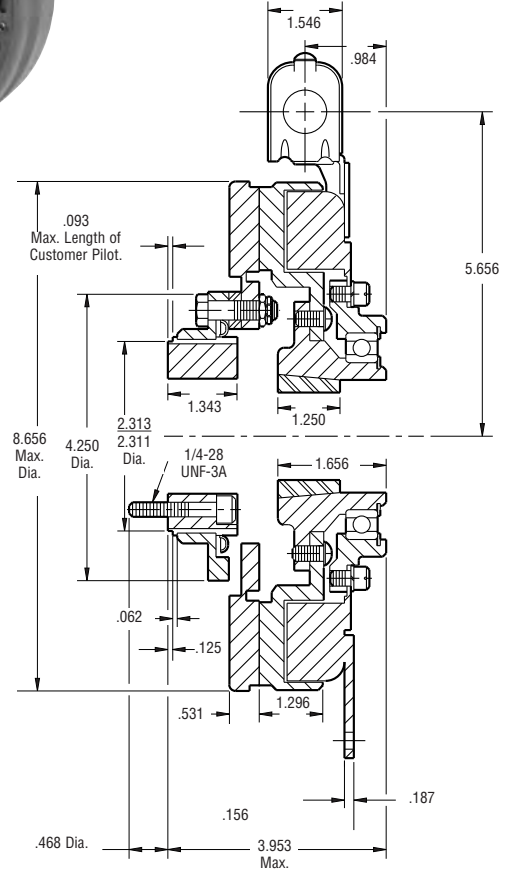

Shaft Size	.500 – 1.500
Static Torque	150 lb.ft.
Maximum Speed	3,600 rpm
Standard Voltage	D.C. 6, 24, 90

All dimensions are nominal unless otherwise noted.

Information on inertia and weights begins on page 239. Coil data is on pages 250 and 251.

### Customer Shall Maintain:

1. Armature hub pilot diameter to be concentric with field and rotor mounting shaft within .010 T.I.R.



## SF-825 Bearing Mounted

Drawing I-25573

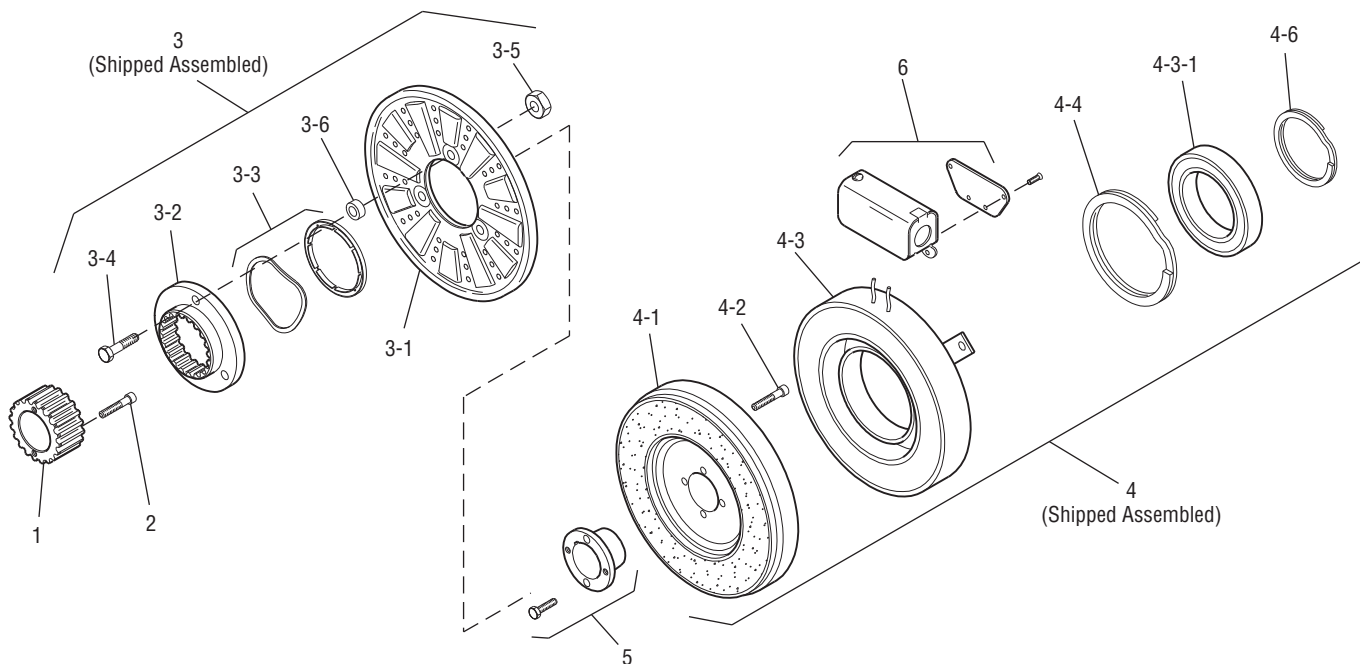

Item	Description	Part Number	Qty.
1	Splined Hub	540-0146	1
2	Accessory, Mounting	5201-101-001	1
3	Armature & Adapter Assembly	5201-111-001	1
3-1	Armature	5321-111-022	1
3-2	Splined Adapter	104-0008	1
3-3	Autogap Accessory	5321-101-006	1
3-4	Screw	797-0341	3
3-5	Locknut	661-0004	3
3-6	Spacer	748-0333	3
4	Field & Rotor Assembly		1
	6 Volt	5201-452-002	
	24 Volt	5201-452-004	
	90 Volt	5201-452-006	
4-1	Rotor	5201-751-008	1
4-2	Mounting Accessory	5201-101-005	1
4-3	Field & Bearing Assembly		1
	6 Volt	5201-451-054	
	24 Volt	5201-451-056	
	90 Volt	5201-451-057	

Item	Description	Part Number	Qty.
4-3-1	Ball Bearing	166-0142	1
4-4	Retainer Ring	748-0111	1
4-6	Retainer Ring	748-0016	1
5	Bushing*	180-0002 to 180-0018	1
6	Conduit Box	5200-101-012	1

### How to Order:

1. Specify Bore Size for Item 5.
2. Specify Voltage for Item 4.
3. See Controls Section.

### Example:

SF-825 Clutch per I-25573 - 90 Volt, 1" Bore

These units, when used in conjunction with the correct Warner Electric conduit box, meet the standards of UL508 and are listed under guide card #NMTR, file #59164. These units are CSA certified under file #LR11543.

\*See page 252 for specific part numbers.

Refer to Service Manual P-215.

## SF-1000 Flange Mounted



See page 230  
for Drive Pin  
mountings.

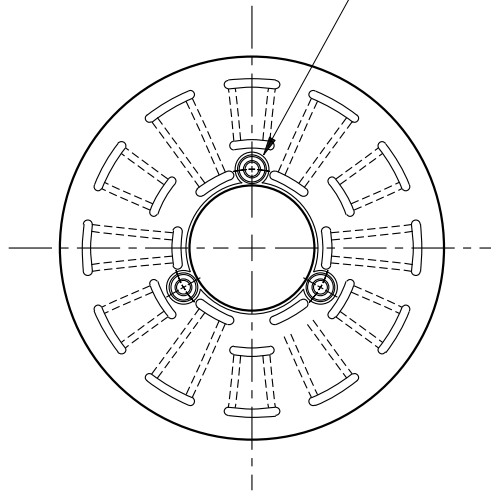

**ARMATURE VIEW**

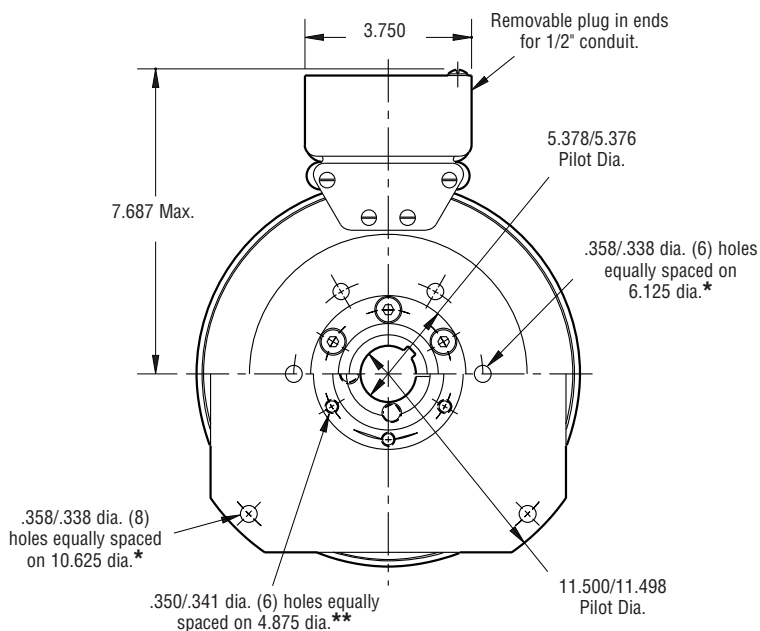

**FIELD VIEW**

(Inside & Outside Mounted)

### Customer Shall Maintain:

1. Concentricity of field mounting pilot diameter with rotor mounting shaft within .006 T.I.R.
2. Squareness of field mounting face with shaft within .006 T.I.R. measured at field mounting bolt circle.

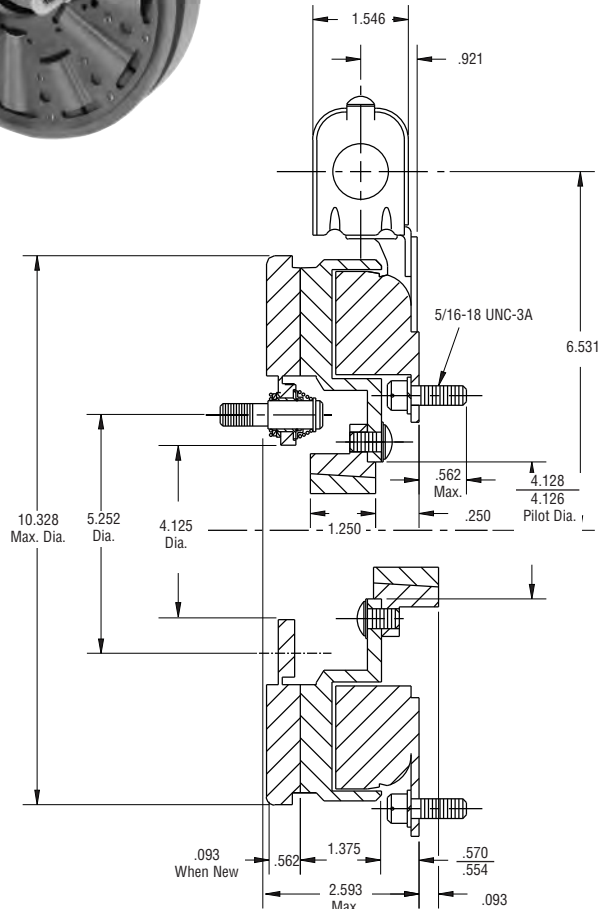

\* Mounting holes are within .010 of true position relative to pilot diameter.

\*\* Mounting holes are within .008 of true position relative to pilot diameter.

Shaft Size	.500 – 2.000
Static Torque	240 lb.ft.
Maximum Speed	3,600 rpm
Standard Voltage	D.C. 6, 24, 90

All dimensions are nominal unless otherwise noted.

Information on inertia and weights begins on page 239. Coil data is on pages 250 and 251.



## SF-1000 Flange Mounted

Drawing I-25580

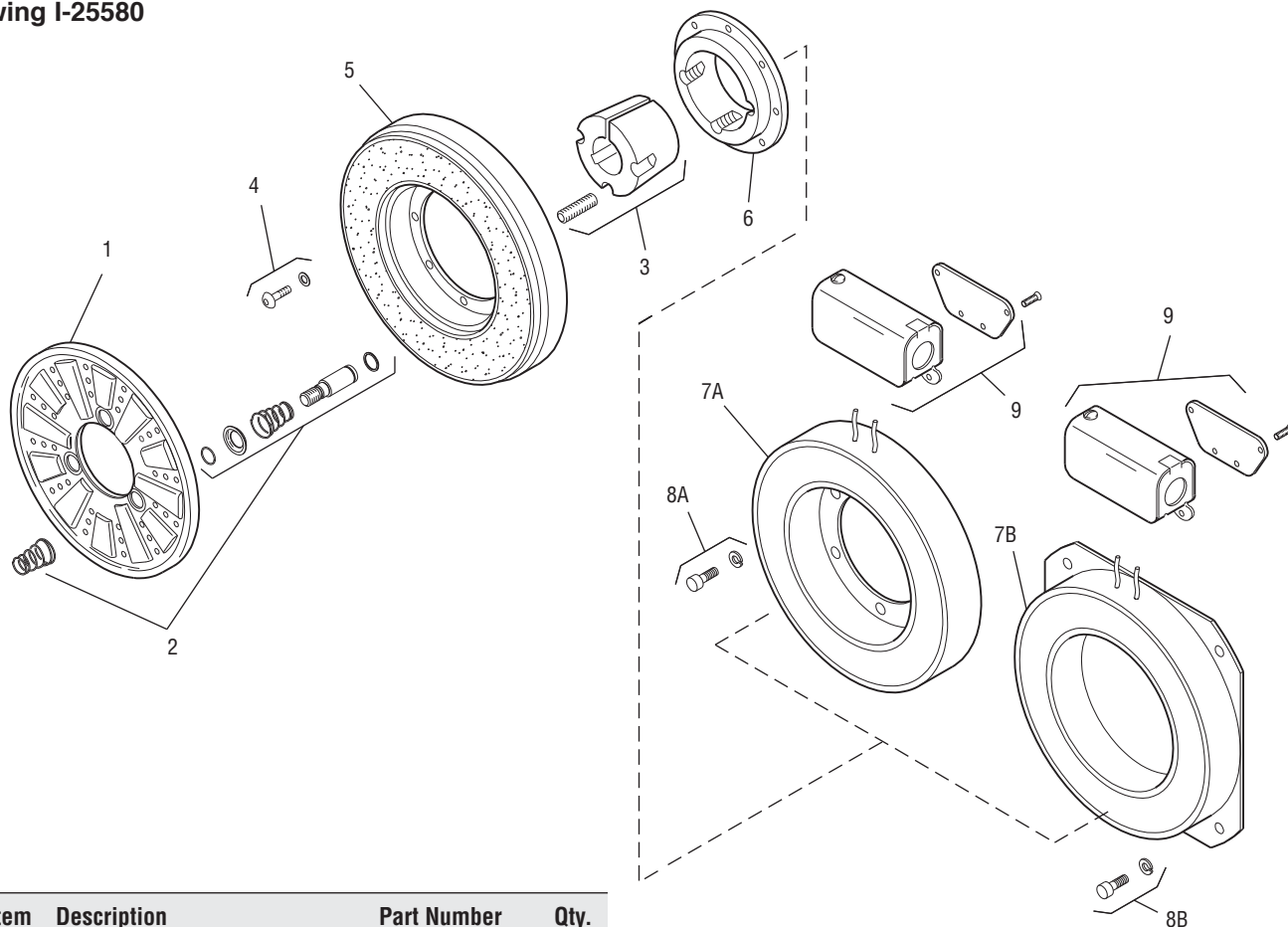

Item	Description	Part Number	Qty.
1	Armature	5302-111-013	1
2	Autogap Accessory	5201-101-008	3
3	Bushing*		1
	1/2" to 2" Bore	180-0155 to 180-0179	
4	Mounting Accessory	5201-101-007	1
5	Rotor		1
	Standard Friction Material	5202-751-003	
	†Optional LK Facing	5202-751-007	
6	Rotor Hub	540-0315	1
7A	Field - Inside Mounted		1
	6 Volt	5202-451-004	
	24 Volt	5202-451-006	
	90 Volt	5202-451-007	
7B	Field - Outside Mounted		1
	6 Volt	5202-451-011	
	24 Volt	5202-451-013	
	90 Volt	5202-451-014	
8A	Mounting Accessory - I.M.	5321-101-001	1
8B	Mounting Accessory - O.M.	5321-101-002	2
9	Conduit Box	5200-101-012	1

### How to Order:

1. Specify Bore Size for Item 3.
2. Specify Voltage for Items 8A or 8B.
3. Specify Inside Mounted for Items 7A and 8A or Outside Mounted for Items 7B and 8B.
4. See Controls Section.

### Example:

SF-1000 Clutch per I-25580 -90 Volt, 1" Bore, Inside Mounted

These units, when used in conjunction with the correct Warner Electric conduit box, meet the standards of UL508 and are listed under guide card #NMTR, file #59164.

These units are CSA certified under file #LR11543.

\*See page 252 for specific part numbers.

Refer to Service Manual P-222.

†Optional LK facing available. For more information, see page 232.

## SF-1000 Bearing Mounted



See page 252 for details on Bushings.

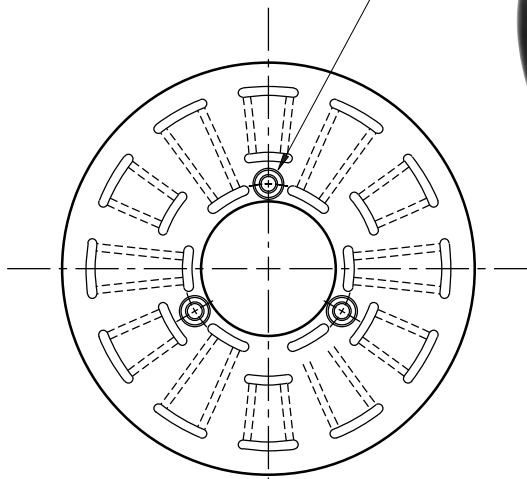

**ARMATURE VIEW**

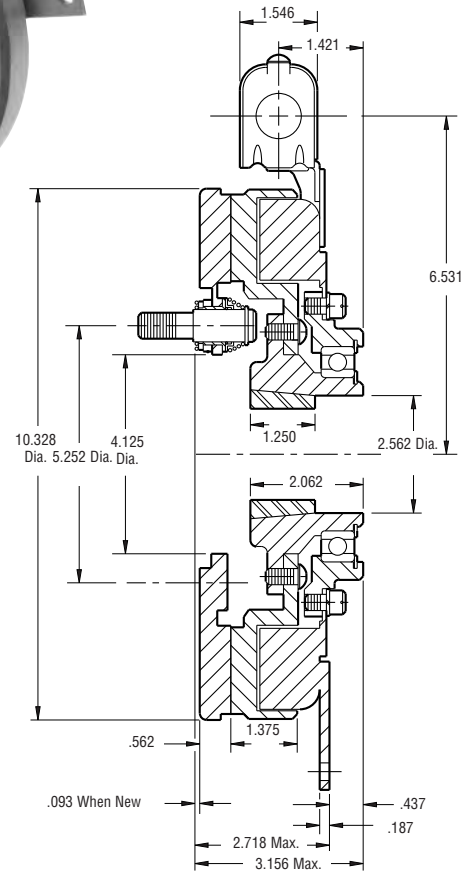

Removable plug in ends for 1/2" conduit.

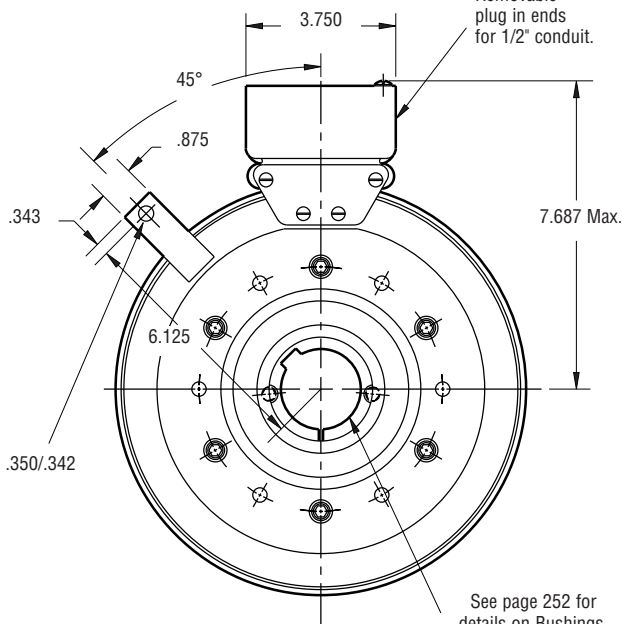

See page 252 for details on Bushings.

**FIELD VIEW**

Shaft Size	.500 – 2.000
Static Torque	240 lb.ft.
Maximum Speed	2,500 rpm
Standard Voltage	D.C. 6, 24, 90

All dimensions are nominal unless otherwise noted.

Information on inertia and weights begins on page 239. Coil data is on pages 250 and 251.





## SF-1000 Bearing Mounted

Drawing I-25596

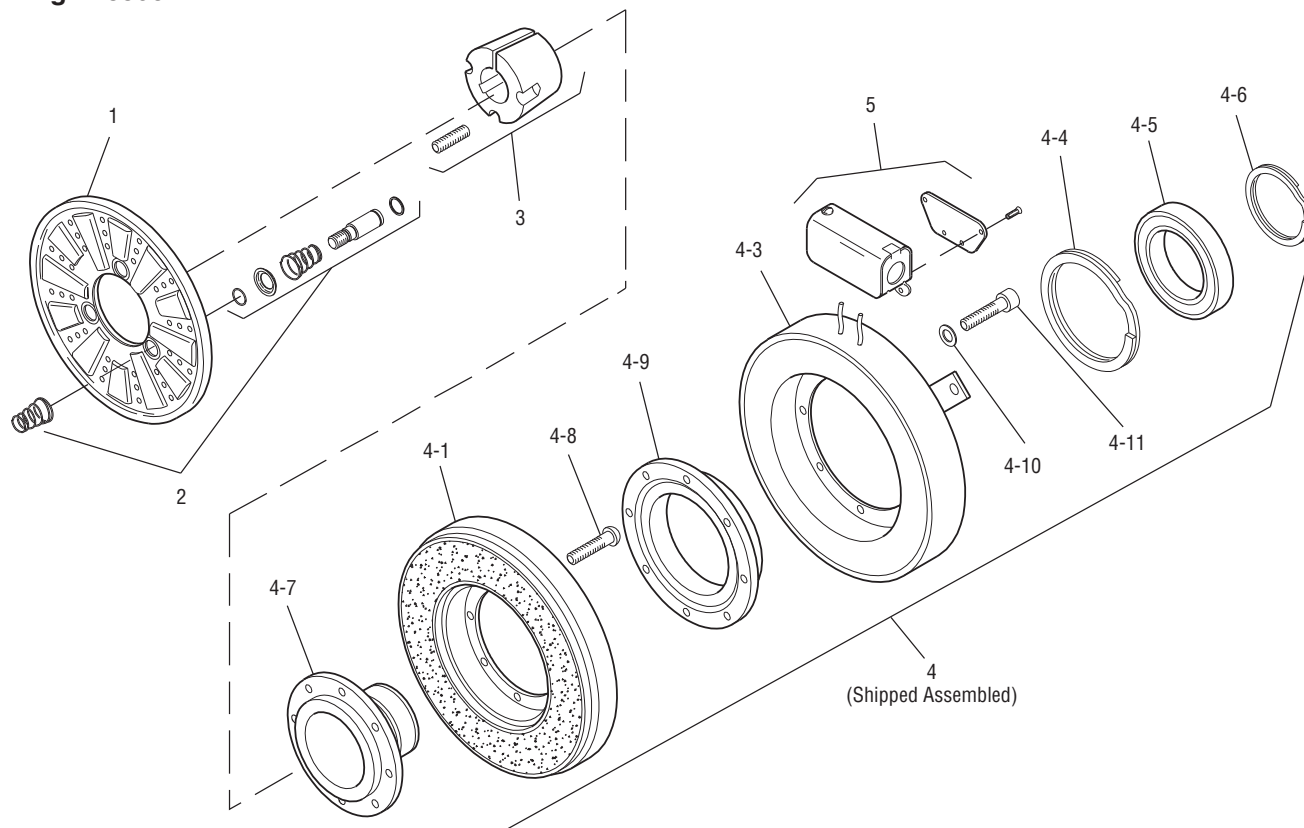

Item	Description	Part Number	Qty.
1	Armature	5302-111-013	1
2	Autogap Accessory	5201-101-008	3
3	Bushing*		1
	1/2" to 2" Bore	180-0155 to 180-0179	
4	Field & Rotor Assembly		1
	6 Volt	5202-452-012	
	24 Volt	5202-452-014	
	90 Volt	5202-452-015	
4-1	Rotor		1
	Standard Friction Material	5202-751-003	
	†Optional LK Facing	5202-751-007	
4-3	Field & Bearing Assembly		1
	6 Volt	5202-451-040	
	24 Volt	5202-451-042	
	90 Volt	5202-451-043	
4-4	Retainer Ring	748-0116	1
4-5	Ball Bearing	166-1046	1
4-6	Retainer Ring	748-0582	1
4-7	Rotor Hub	540-1300	1

Item	Description	Part Number	Qty.
4-8	Buttonhead Capscrew	797-1261	6
4-9	Ring Adapter	748-1047	1
4-10	Lockwasher	950-0359	6
4-11	Socket Head Capscrew	797-0424	6
5	Conduit Box	5200-101-012	1

### How to Order:

1. Specify Bore Size for Item 3.
2. Specify Voltage for Item 4.
3. See Controls Section.

### Example:

SF-1000 Clutch per I-25596 - 90 Volt, 1" Bore

These units, when used in conjunction with the correct Warner Electric conduit box, meet the standards of UL508 and are listed under guide card #NMTR, file #59164. These units are CSA certified under file #LR11543.

\*See page 252 for specific part numbers.

Refer to Service Manual P-215.

†Optional LK facing available. For more information, see page 232.

SF-1000 Flange Mounted



.397/.388 dia. 3 holes (hub) equally spaced on 3.187 dia. Mounting holes are within .003 of true position relative to pilot dia.

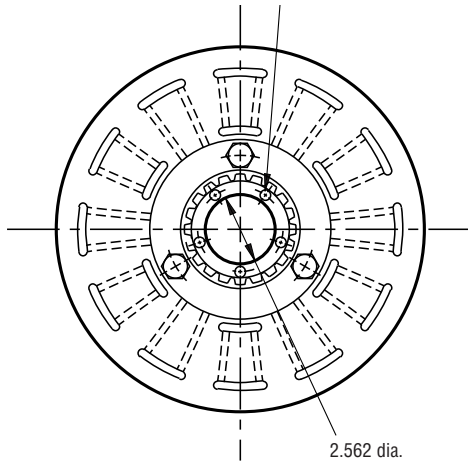

ARMATURE VIEW

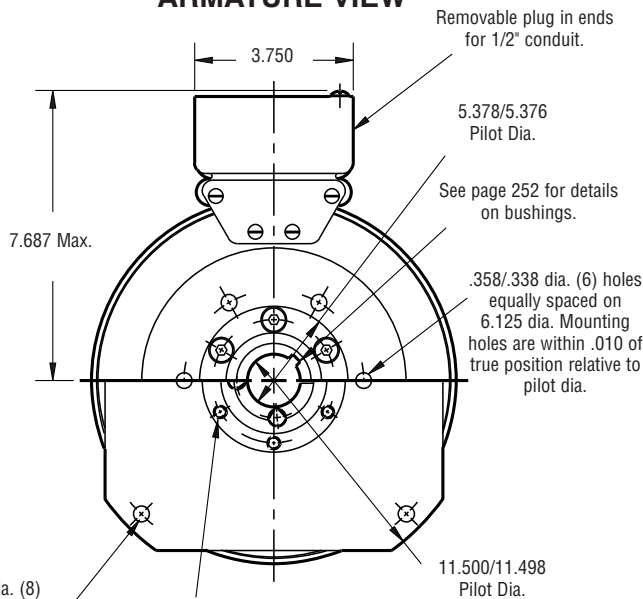

FIELD VIEW  
(Inside & Outside Mounted)

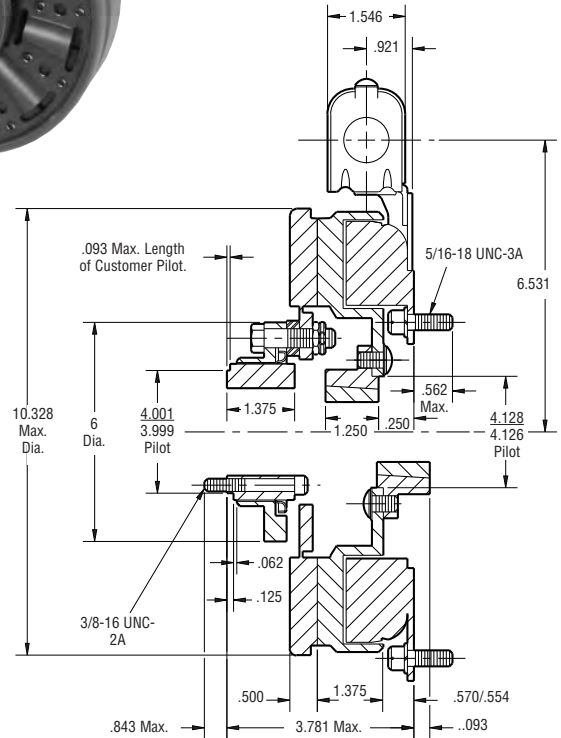

.358/.338 dia. (8) holes equally spaced on 10.625 dia. are within .010 of true position relative to pilot dia.

.350/.341 dia. (6) holes equally spaced on 4.875 dia. Mounting holes are within .008 of true position relative to pilot dia.

Removable plug in ends for 1/2" conduit.

5.378/5.376 Pilot Dia.

See page 252 for details on bushings.

.358/.338 dia. (6) holes equally spaced on 6.125 dia. Mounting holes are within .010 of true position relative to pilot dia.

11.500/11.498 Pilot Dia.

Shaft Size	.500 – 2.000
Static Torque	240 lb.ft.
Maximum Speed	3,600 rpm
Standard Voltage	D.C. 6, 24, 90

Customer Shall Maintain:

1. Concentricity of field mounting pilot diameter with rotor mounting shaft within .006 T.I.R.
2. Squareness of field mounting face with shaft within .006 T.I.R. measured at field mounting bolt circle.
3. Rotor mounting shaft concentric with armature hub pilot diameter within .010 T.I.R.

When Hub is Furnished by Customer:

Rotor mounting pilot diameter must be concentric with rotor mounting shaft within .006 T.I.R.

All dimensions are nominal unless otherwise noted.

Information on inertia and weights begins on page 239. Coil data is on pages 250 and 251.



Drawing I-25581

## SF-1000 Flange Mounted

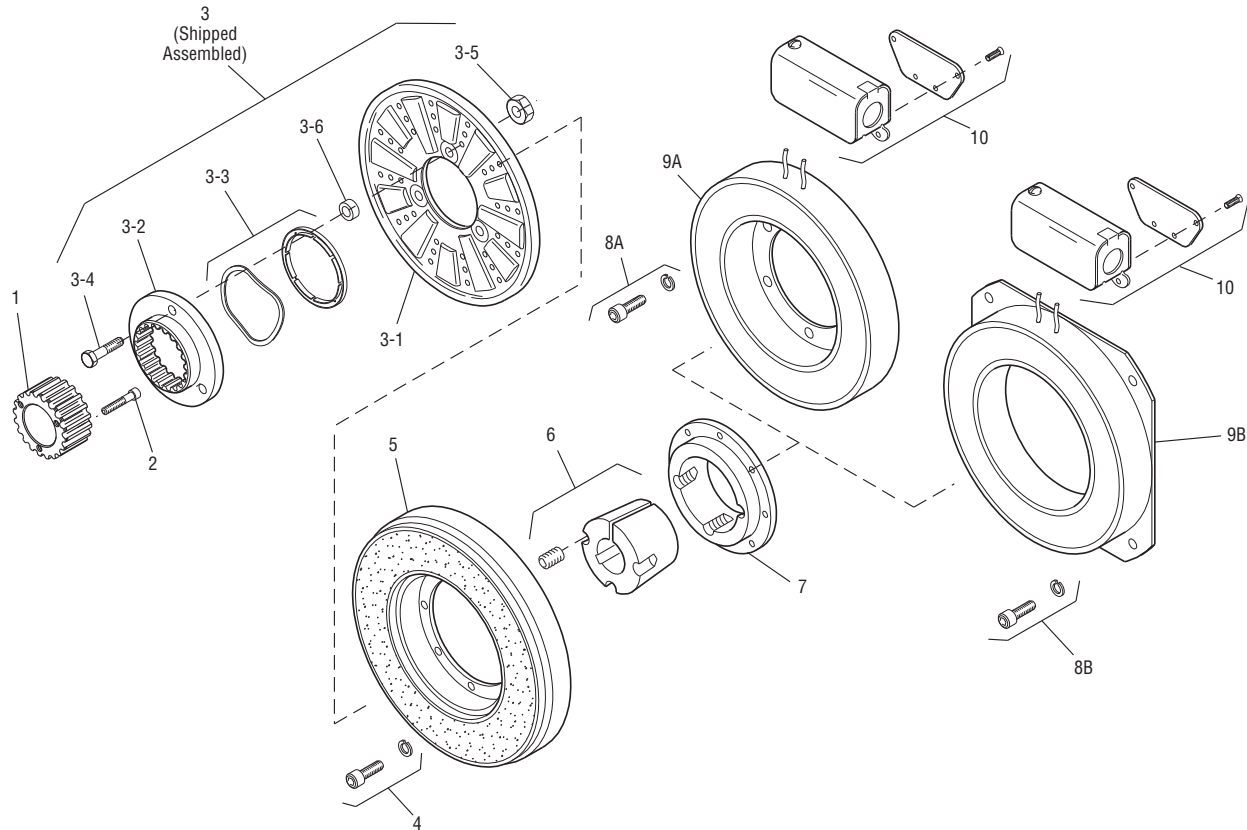

Item	Description	Part Number	Qty.
1	Splined Hub	540-0147	1
2	Mounting Accessory	5202-101-001	1
3	Armature & Splined Adapter	5202-111-001	1
3-1	Armature	5322-111-036	1
3-2	Splined Adapter	104-0009	1
3-3	Autogap Accessory	5322-101-004	1
3-4	Screw	797-0341	3
3-5	Locknut	661-0004	3
3-6	Spacer	748-0333	3
4	Mounting Accessory	5201-101-007	1
5	Rotor		1
	Standard Friction Material	5202-751-003	
	†Optional LK Facing	5202-751-007	
6	Bushing, Taperlock*	180-0155 to 180-0179	1
7	Rotor Hub	540-0315	1
8A	Mounting Accessory, I.M.	5321-101-001	1
8B	Mounting Accessory, O.M.	5321-101-002	2
9A	Field, Inside Mounted		1
	6 Volt	5202-451-004	
	24 Volt	5202-451-006	
	90 Volt	5202-451-007	

Item	Description	Part Number	Qty.
9B	Field, Outside Mounted		1
	6 Volt	5202-451-011	
	24 Volt	5202-451-013	
	90 Volt	5202-451-014	
10	Conduit Box	5200-101-012	1

### How to Order:

1. Specify Bore Size for Item 6.
2. Specify Voltage for Item 9A or 9B.
3. Specify Inside Mounted for Items 8A and 9A or Outside Mounted for Items 8B and 9B.
4. See Controls Section.

### Example:

SF-1000 Clutch Coupling, Heavy Duty per I-25581 - 90 Volt, Inside Mounted, 1-1/4" Bore (Item 6)

These units, when used in conjunction with the correct Warner Electric conduit box, meet the standards of UL508 and are listed under guide card #NMTR, file #59164. These units are CSA certified under file #LR11543

\*See page 252 for specific part numbers.

Refer to Service Manual P-215.

†Optional LK facing available. For more information, see page 232.

## SF-1000 Bearing Mounted

.397/.388 dia. 3 holes (hub) equally spaced on 3.187 dia. and within .003 of true position relation to 4.001/3.999 pilot dia.

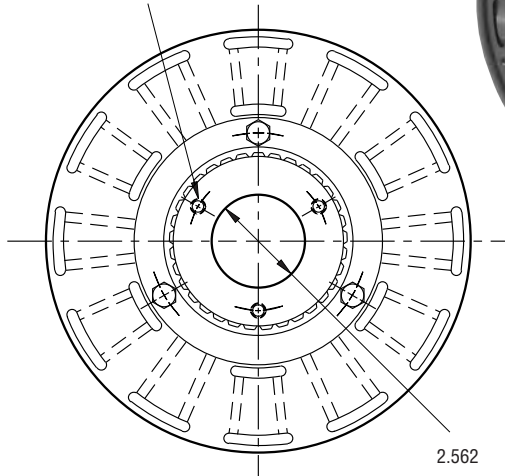

**ARMATURE VIEW**

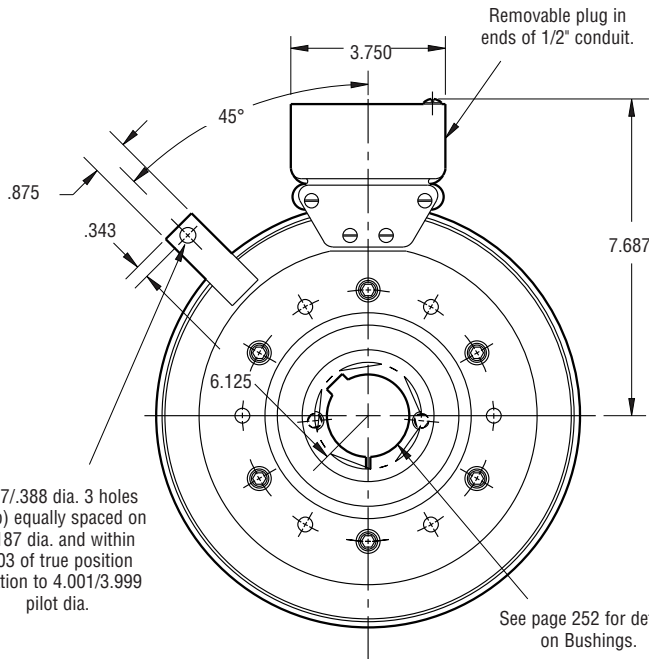
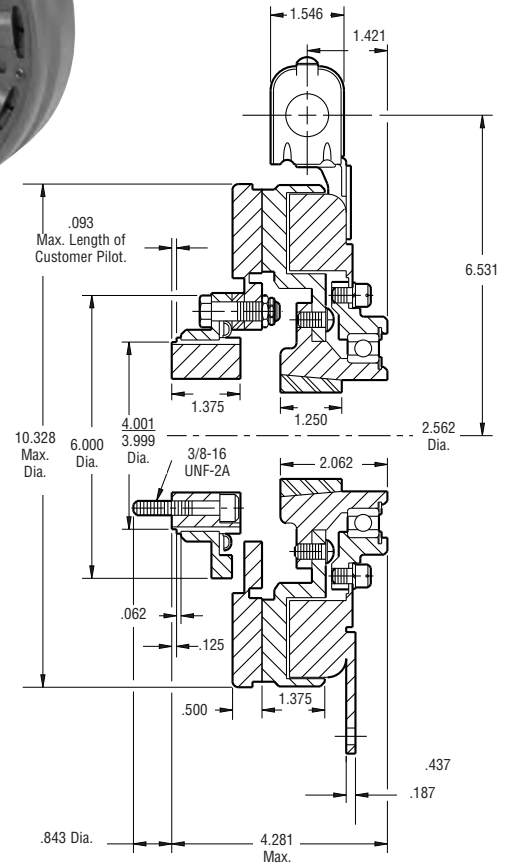

**FIELD VIEW**

.397/.388 dia. 3 holes (hub) equally spaced on 3.187 dia. and within .003 of true position relation to 4.001/3.999 pilot dia.

See page 252 for details on Bushings.

Shaft Size	.500 – 2.000
Static Torque	240 lb.ft.
Maximum Speed	2,500 rpm
Standard Voltage	D.C. 6, 24, 90

All dimensions are nominal unless otherwise noted.

Information on inertia and weights begins on page 239. Coil data is on pages 250 and 251.

### Customer Shall Maintain:

1. Armature hub pilot diameter to be concentric with field and rotor mounting shaft within .010 T.I.R.



## SF-1000 Bearing Mounted

Drawing I-25597

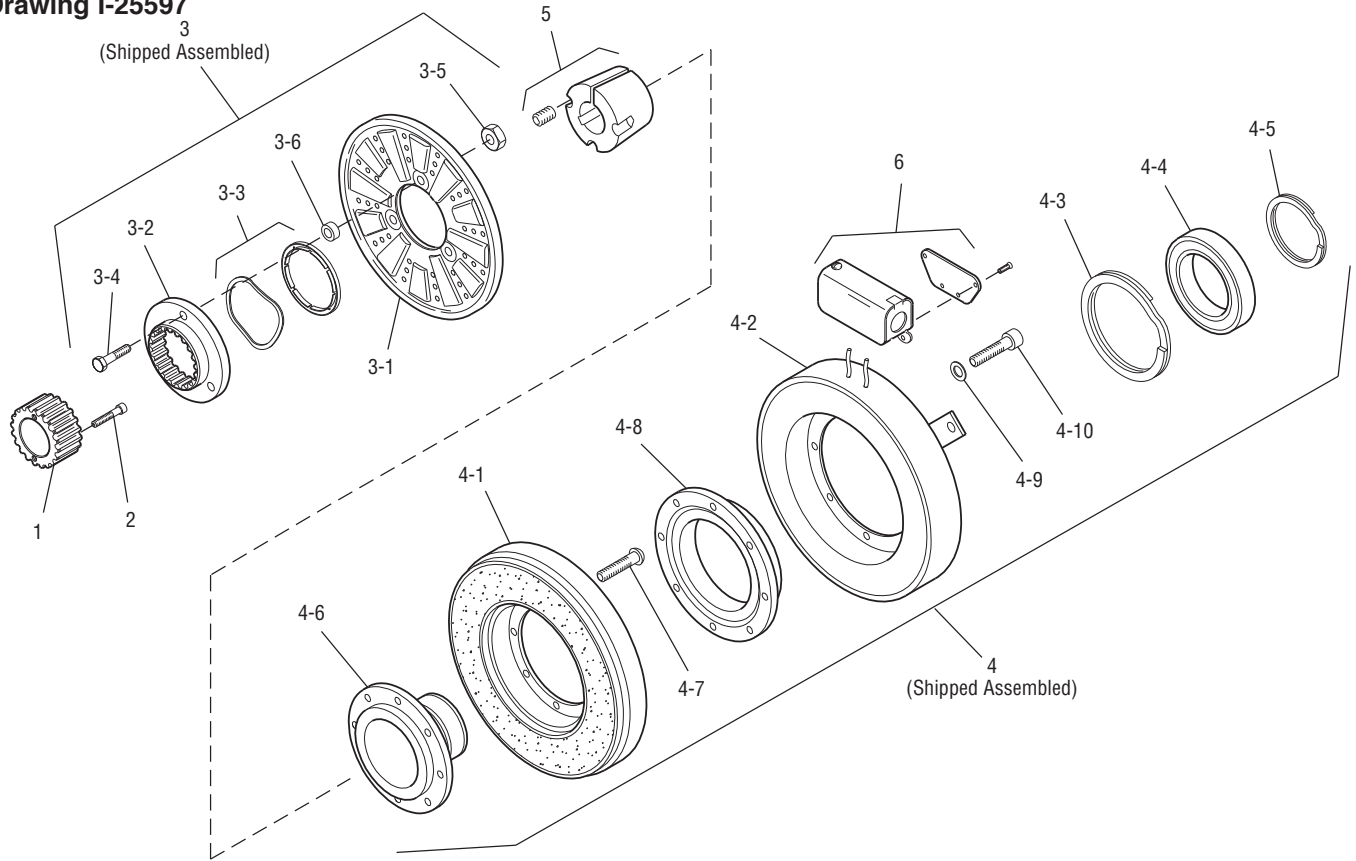

Item	Description	Part Number	Qty.
1	Splined Hub	540-0147	1
2	Accessory, Mounting	5202-101-001	1
3	Armature & Adapter Assembly	5202-111-001	1
3-1	Armature	5322-111-036	1
3-2	Splined Adapter	104-0009	1
3-3	Autogap Accessory	5322-101-004	1
3-4	Screw	797-0341	3
3-5	Locknut	661-0004	3
3-6	Spacer	748-0333	3
4	Field & Rotor Assembly		1
	6 Volt	5202-452-012	
	24 Volt	5202-452-014	
	90 Volt	5202-452-015	
4-1	Rotor		1
	Standard Friction Material	5202-751-003	
	†Optional LK Facing	5202-751-007	
4-2	Field & Bearing Assembly		1
	6 Volt	5202-451-040	
	24 Volt	5202-451-042	
	90 Volt	5202-451-043	
4-3	Retainer Ring	748-0116	1

Item	Description	Part Number	Qty.
4-4	Ball Bearing	166-1046	1
4-5	Retainer Ring	748-0582	1
4-6	Rotor Hub	540-1300	1
4-7	Buttonhead Capscrew	797-1261	6
4-8	Ring Adapter	748-1047	1
4-9	Lockwasher	950-0359	6
4-10	Socket Head Capscrew	797-0422	6
5	Bushing*	180-0155 to 180-0179	1
6	Conduit Box	5200-101-012	1

### How to Order:

1. Specify Bore Size for Item 5.
2. Specify Voltage for Item 4.
3. See Controls Section.

### Example:

SF-1000 Clutch per I-25597 - 90 Volt, 1" Bore

These units, when used in conjunction with the correct Warner Electric conduit box, meet the standards of UL508 and are listed under guide card #NMTR, file #59164. These units are CSA certified under file #LR11543.

\*See page 252 for specific part numbers.

Refer to Service Manual P-215.

†Optional LK facing available. For more information, see page 232.

**SF-1225 Flange Mounted**



See page 230 for details on Drive Pin mountings.

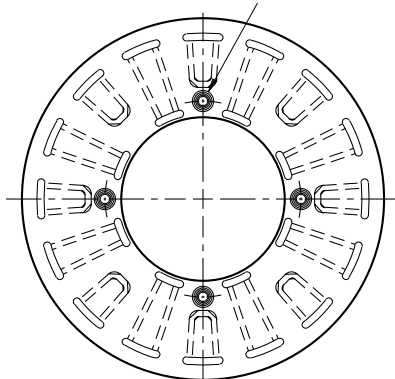

**ARMATURE VIEW**

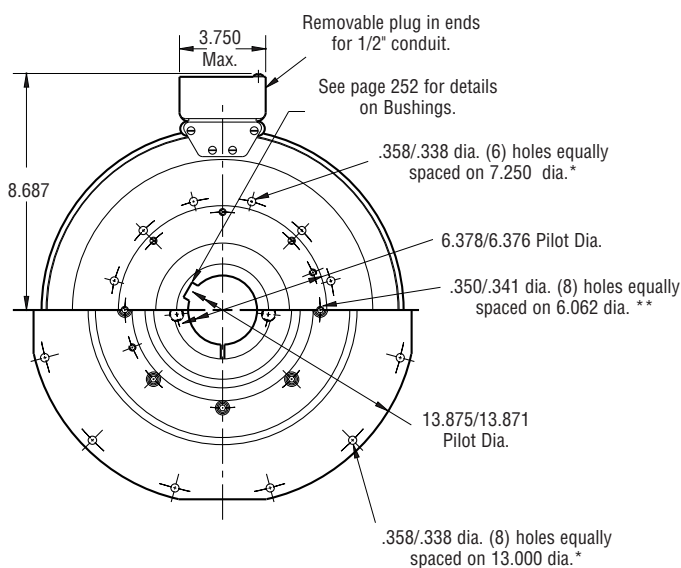

**FIELD VIEW**

**(Inside & Outside Mounted)**

**Customer Shall Maintain:**

1. Concentricity of field mounting pilot diameter with rotor mounting shaft within .006 T.I.R.
2. Squareness of field mounting face with rotor mounting shaft within .006 T.I.R. measured at field mounting bolt circle.
3. Rotor mounting shaft concentric with armature center of rotation within .006 T.I.R.
4. Armature hub pilot diameter to be concentric with armature center of rotation within .010 T.I.R.

**When Hub is Furnished by customer:**

Rotor mounting pilot diameter must be concentric with rotor mounting shaft within .006 T.I.R.

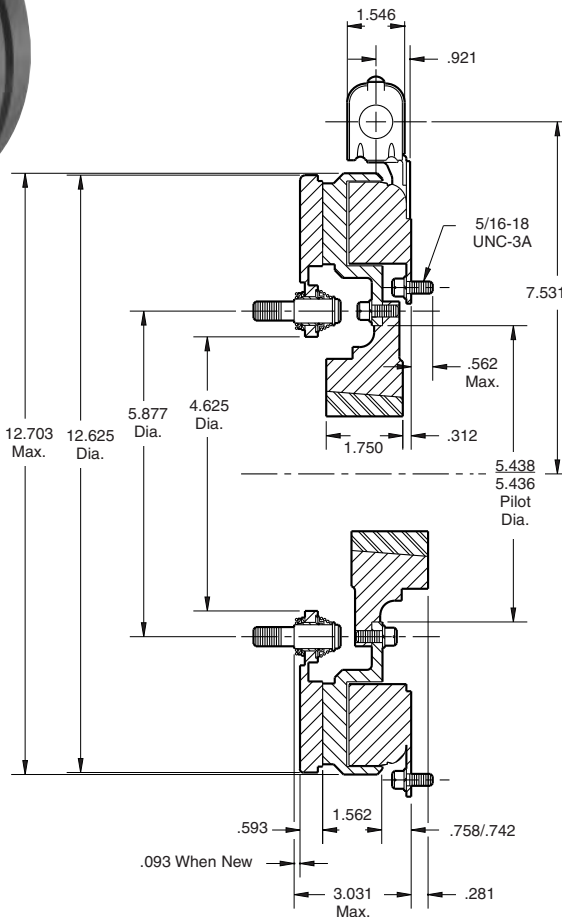

\* Mounting holes are within .010 of true position relative to pilot diameter.

\*\* Mounting holes are within .008 of true position relative to pilot diameter.

Shaft Size	.500 – 2.500
Static Torque	465lb.ft.
Maximum Speed	3,000 rpm
Standard Voltage	D.C. 6, 24, 90

All dimensions are nominal unless otherwise noted.

Information on inertia and weights begins on page 239. Coil data is on pages 250 and 251.

Drawing I-25600

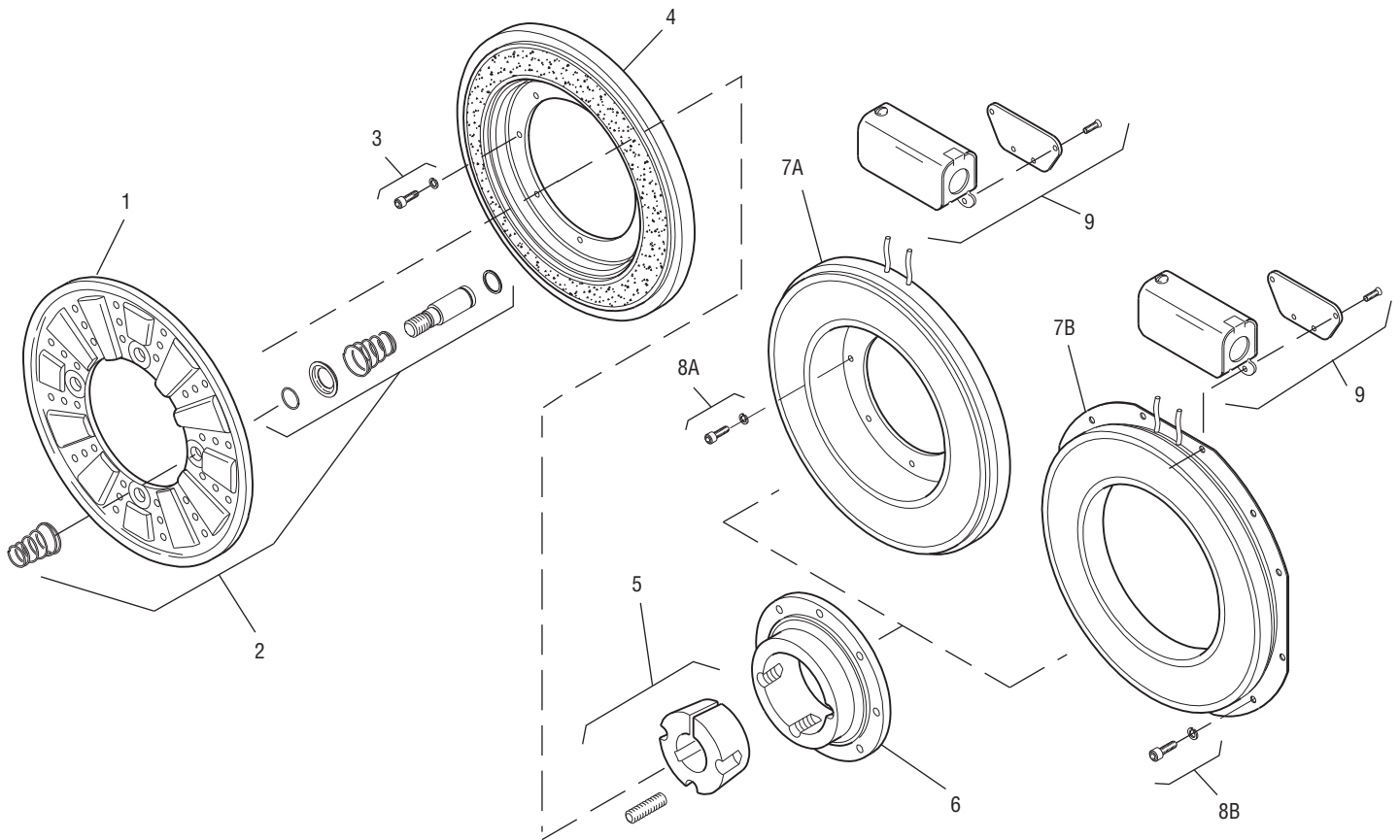

Item	Description	Part Number	Qty.
1	Armature	5303-111-009	1
2	Autgap Accessory	5201-101-008	4
3	Mounting Accessory	5321-101-002	2
4	Rotor		1
	Standard Friction Material	5203-751-001	
	†Optional LK Facing	5203-751-004	
5	Bushing*		1
	1/2" to 2-1/2" Bore	180-0185 to 180-0217	
6	Rotor Hub	540-0318	1
7A	Field - Inside Mounted		1
	6 Volt	5203-451-002	
	24 Volt	5203-451-006	
	90 Volt	5203-451-005	
7B	Field - Outside Mounted		1
	6 Volt	5203-451-010	
	24 Volt	5203-451-013	
	90 Volt	5203-451-011	

Item	Description	Part Number	Qty.
8A	Mounting Accessory - I.M.	5321-101-001	1
8B	Mounting Accessory - O.M.	5321-101-002	2
9	Conduit Box	5200-101-012	1

**How to Order:**

1. Specify Bore Size for Item 5.
2. Specify Voltage for Item 7A or 7B.
3. Specify Inside Mounted for Items 7A and 8A or Outside Mounted for Items 7B and 8B.
4. See Controls Section.

**Example:**

SF-1225 Clutch per I-25600 -  
90 Volt, 1-1/2" Bore, Inside Mounted.

These units, when used in conjunction with the correct Warner Electric conduit box, meet the standards of UL508 and are listed under guide card #NMTR, file #59164. These units are CSA certified under file #LR11543.

\*See page 252 for specific part numbers.

Refer to Service Manual P-215.

†Optional LK facing available. For more information, see page 232.

**SF-1225 Flange Mounted**

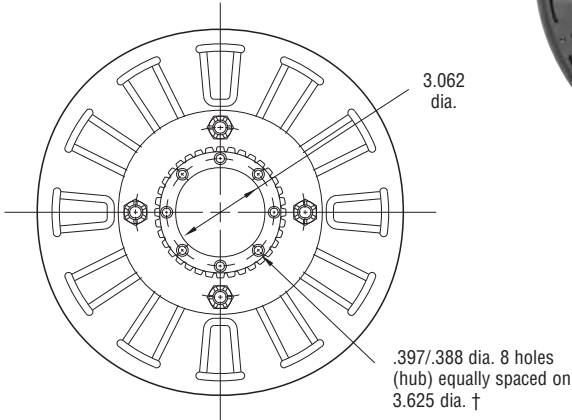

**ARMATURE VIEW**

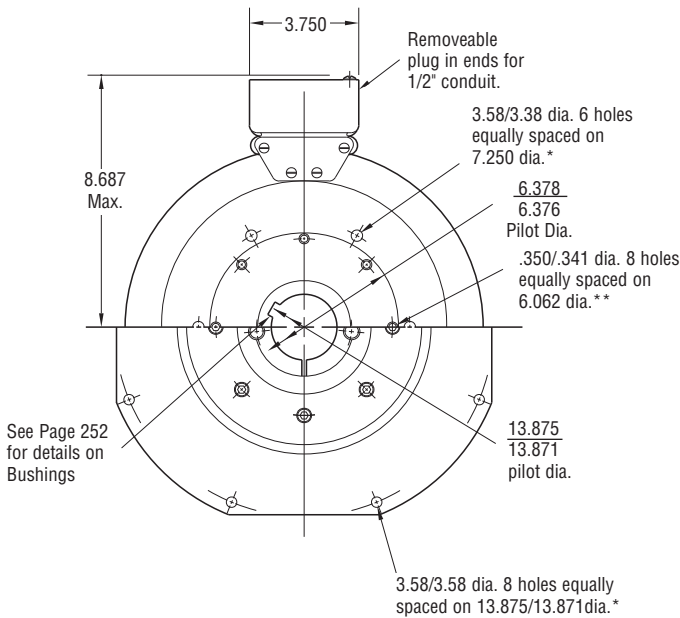

**FIELD VIEW**

**(Inside & Outside Mounted)**

**Customer Shall Maintain:**

1. Concentricity of field mounting pilot diameter with rotor mounting shaft within .006 T.I.R.
2. Squareness of field mounting face with shaft within .006 T.I.R. measured at field mounting bolt circle.
3. Armature hub pilot diameter to be concentric with rotor mounting shaft within .010 T.I.R.

**When Hub is Furnished by customer:**

Rotor mounting pilot diameter must be concentric with rotor mounting shaft within .006 T.I.R.

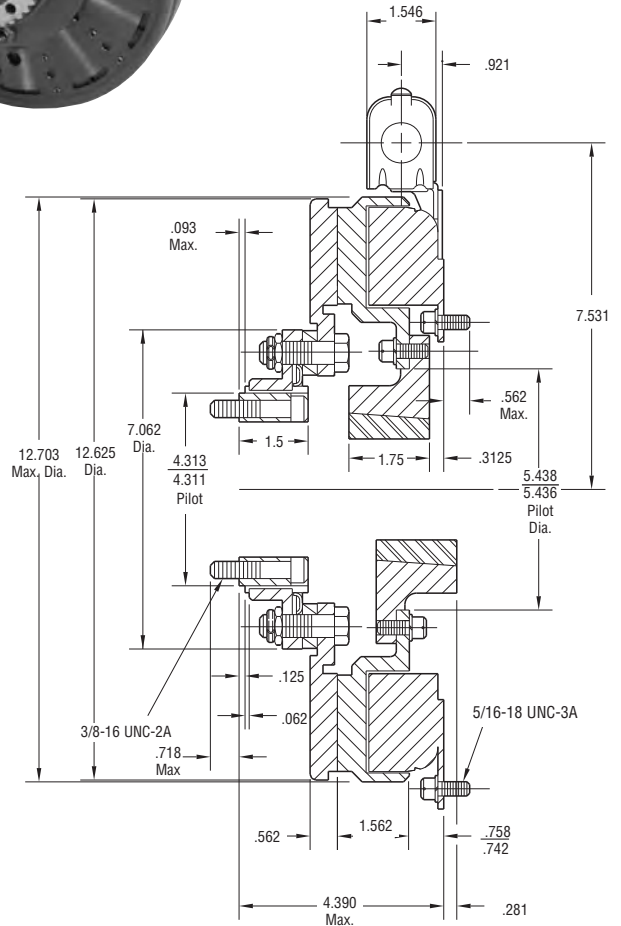

\* Mounting holes are within .010 of true position relative to pilot diameter.

\*\* Mounting holes are within .008 of true position relative to pilot diameter.

† Mounting holes are within .003 of true position relative to pilot diameter.

Shaft Size	.500 – 2.500
Static Torque	465 lb.ft.
Maximum Speed	3,000 rpm
Standard Voltage	D.C. 6, 24, 90

All dimensions are nominal unless otherwise noted.

Information on inertia and weights begins on page 239. Coil data is on pages 250 and 251.





SF-1225 Flange Mounted

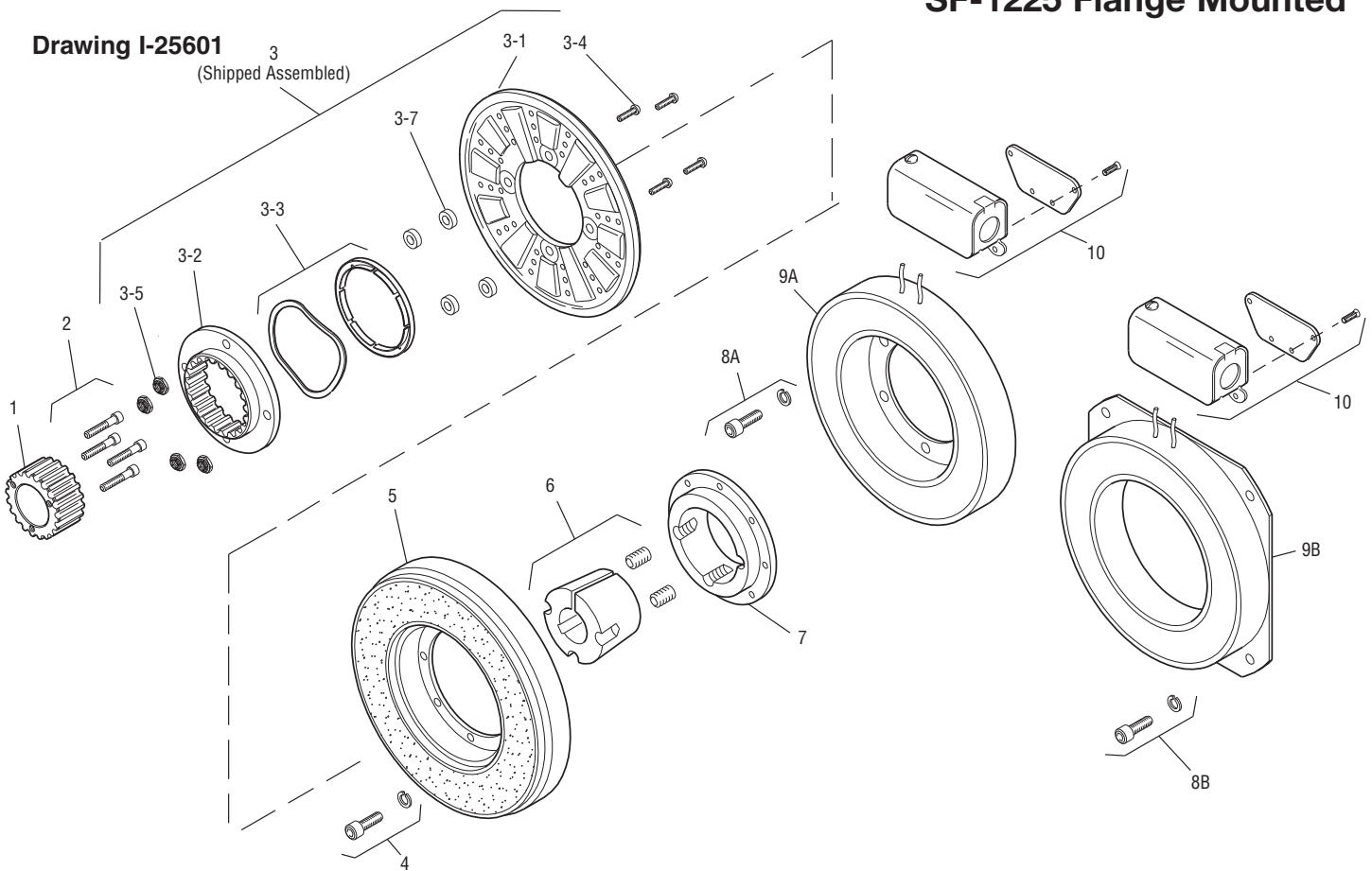

Item	Description	Part Number	Qty.
1	Splined Hub	540-0148	1
2	Mounting Accessory	5202-101-001	1
3	Armature and Splined Adapter	5203-111-001	1
3-1	Armature	5323-111-034	1
3-2	Splined Adapter	104-0010	1
3-3	Autogap Accessory	5323-101-002	1
3-4	Screw	797-0356	4
3-5	Locknut	661-0005	4
3-7	Spacer	266-0004	4
4	Mounting Accessory	5321-101-002	2
5	Rotor		1
	Standard Friction Material	5203-751-001	
	†Optional LK Facing	5203-751-004	
6	Bushing, Taperlock*	180-0185 to 180-0217	1
7	Rotor Hub	540-0318	1
8A	Mounting Accessory, I.M.	5321-101-001	1
8B	Mounting Accessory, O.M.	5321-101-002	2
9A	Field, Inside Mtd.		1
	6 Volt	5203-451-002	
	24 Volt	5203-451-006	
	90 Volt	5203-451-005	

Item	Description	Part Number	Qty.
9B	Field, Outside Mtd.		1
	6 Volts	5203-451-010	
	24 Volts	5203-451-013	
	90 Volts	5203-451-011	
10	Conduit Box	5200-101-012	1

**How to Order:**

1. Specify Bore Size for Item 6.
2. Specify Voltage for Item 9A or 9B.
3. Specify Inside Mounted for Items 8A and 9A or Outside Mounted for Items 8B and 9B.
4. See Controls Section.

**Example:**

SF-1225 Clutch per I-25601 - 90 Volt, 1-1/2" Bore, Inside Mounted.

These units, when used in conjunction with the correct Warner Electric conduit box, meet the standards of UL508 and are listed under guide card #NMTR, file #59164. These units are CSA certified under file #LR11543.

\*See page 252 for specific part numbers.

Refer to Service Manual P-215.

†Optional LK facing available. For more information, see page 232.

## SF-1225 Bearing Mounted

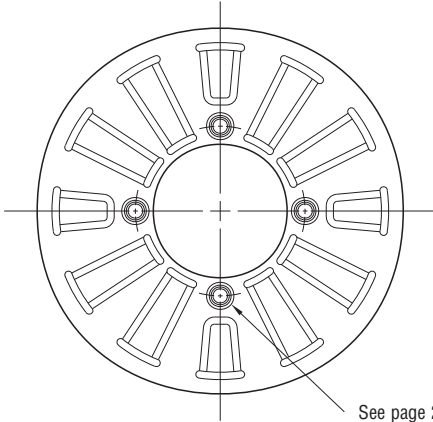
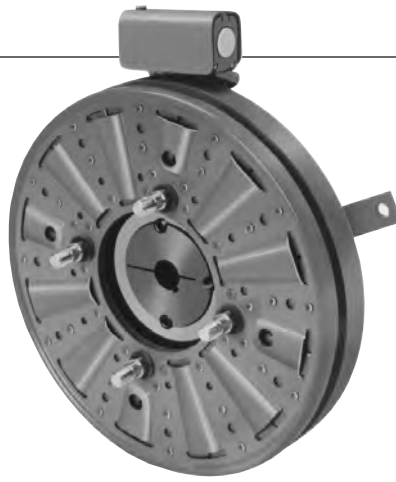

See page 230 for details on Drive Pin mountings.

### ARMATURE VIEW

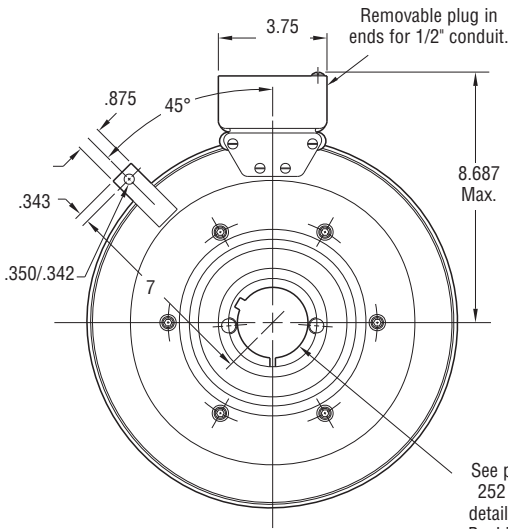

### FIELD VIEW

See page 252 for details on Bushings.

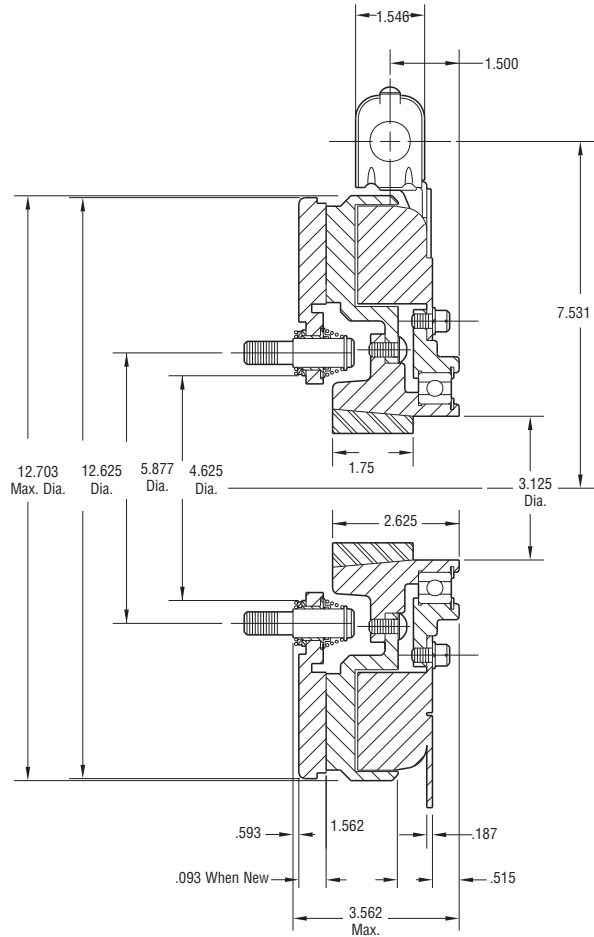

Shaft Size	.500 – 2.500
Static Torque	465 lb.ft.
Maximum Speed	2,200 rpm
Standard Voltage	D.C. 6, 24, 90

All dimensions are nominal unless otherwise noted.

Information on inertia and weights begins on page 239. Coil data is on pages 250 and 251.



Drawing I-25621

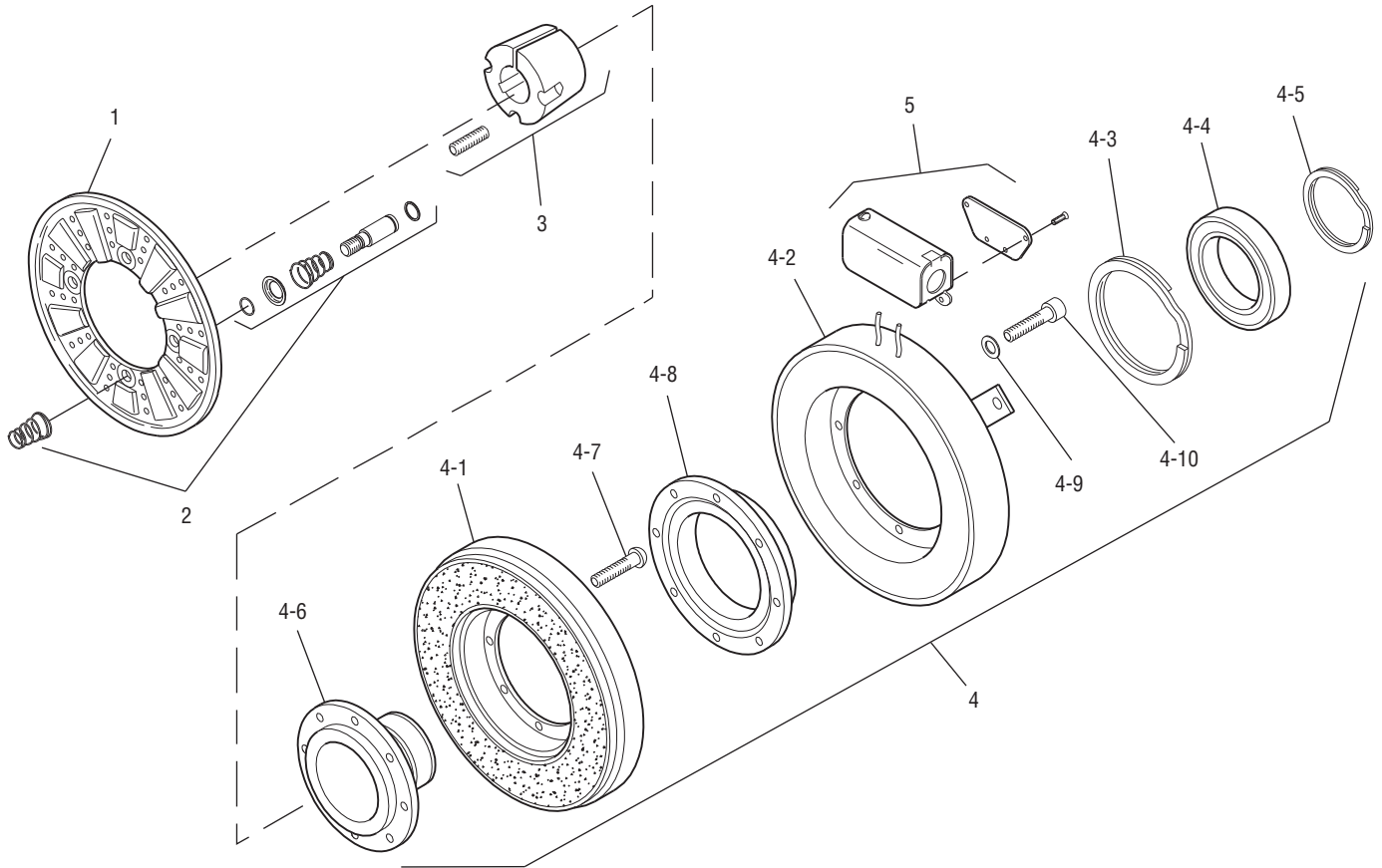

Item	Description	Part Number	Qty.
1	Armature	5303-111-009	1
2	Autogap Accessory	5201-101-008	4
3	Bushing*	1/2" to 2-1/2" Bore 180-0185 to 180-0217	1
4	Field and Rotor Assembly		1
	6 Volt	5203-452-009	
	24 Volt	5203-452-011	
	90 Volt	5203-452-012	
4-1	Rotor		1
	Standard Friction Material	5203-751-001	
	†Optional LK Facing	5203-751-004	
4-2	Field		1
	6 Volt	5203-451-034	
	24 Volt	5203-451-036	
	90 Volt	5203-451-037	
4-3	Retainer Ring	748-0119	1
4-4	Ball Bearing	166-1047	1
4-5	Retainer Ring	748-0011	1
4-6	Rotor Hub	540-1304	1

Item	Description	Part Number	Qty.
4-7	Buttonhead Capscrew	797-1261	8
4-8	Ring Adapter	748-0591	1
4-9	Lockwasher	950-0359	6
4-10	Sockethead Capscrew	797-0424	6
5	Conduit Box	5200-101-012	1

**How to Order:**

1. Specify Bore Size for Item 3.
2. Specify Voltage for Item 4.
3. See Controls Section.

**Example:**

SF-1225 Clutch per I-25621 - 90 Volt, 1" Bore.

These units, when used in conjunction with the correct Warner Electric conduit box, meet the standards of UL508 and are listed under guide card #NMTR, file #59164. These units are CSA certified under file #LR11543.

\*See page 252 for specific part numbers.

Refer to Service Manual P-215.

†Optional LK facing available. For more information, see page 232.

SF-1225 Bearing Mounted

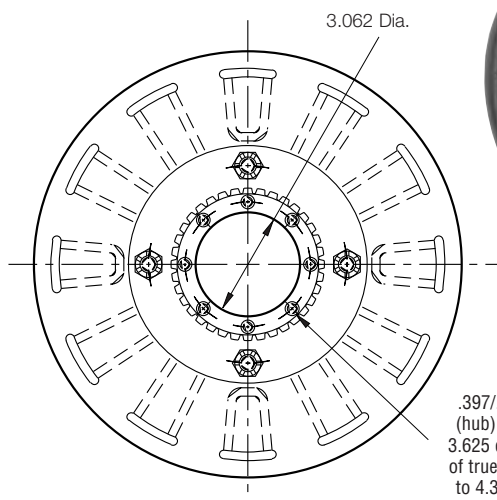
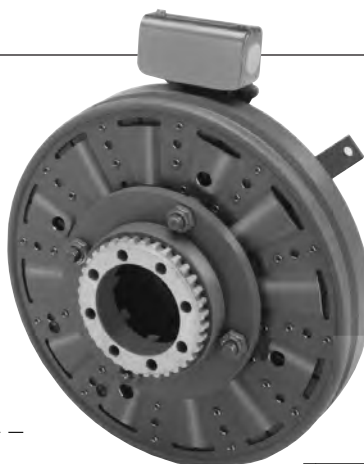

ARMATURE VIEW

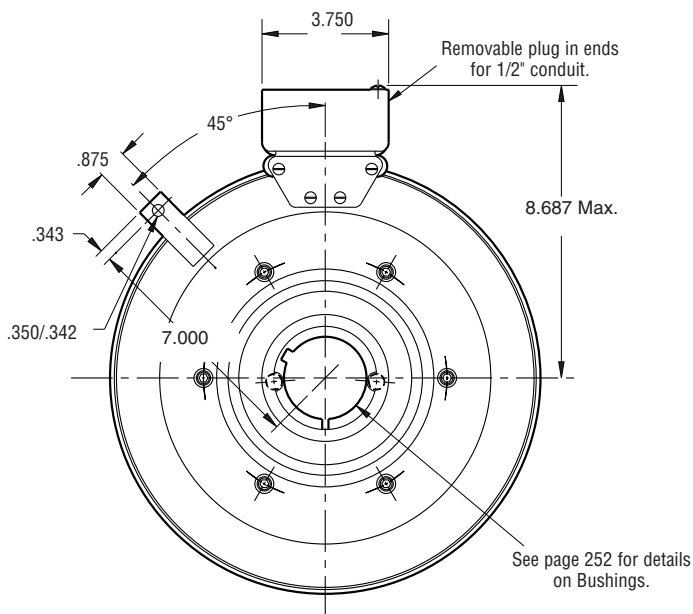

FIELD VIEW

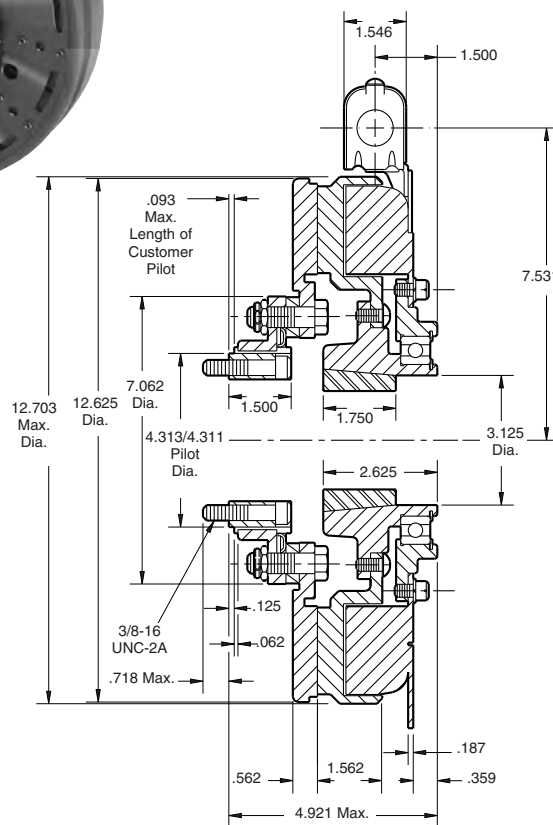

Shaft Size	.500 – 2.500
Static Torque	465 lb.ft.
Maximum Speed	2,200 rpm
Standard Voltage	D.C. 6, 24, 90

All dimensions are nominal unless otherwise noted.

Information on inertia and weights begins on page 239. Coil data is on pages 250 and 251.

Customer Shall Maintain:

1. Armature hub pilot diameter to be concentric with field and rotor mounting shaft within .010 T.I.R.



SF-1225 Bearing Mounted

Drawing I-25622

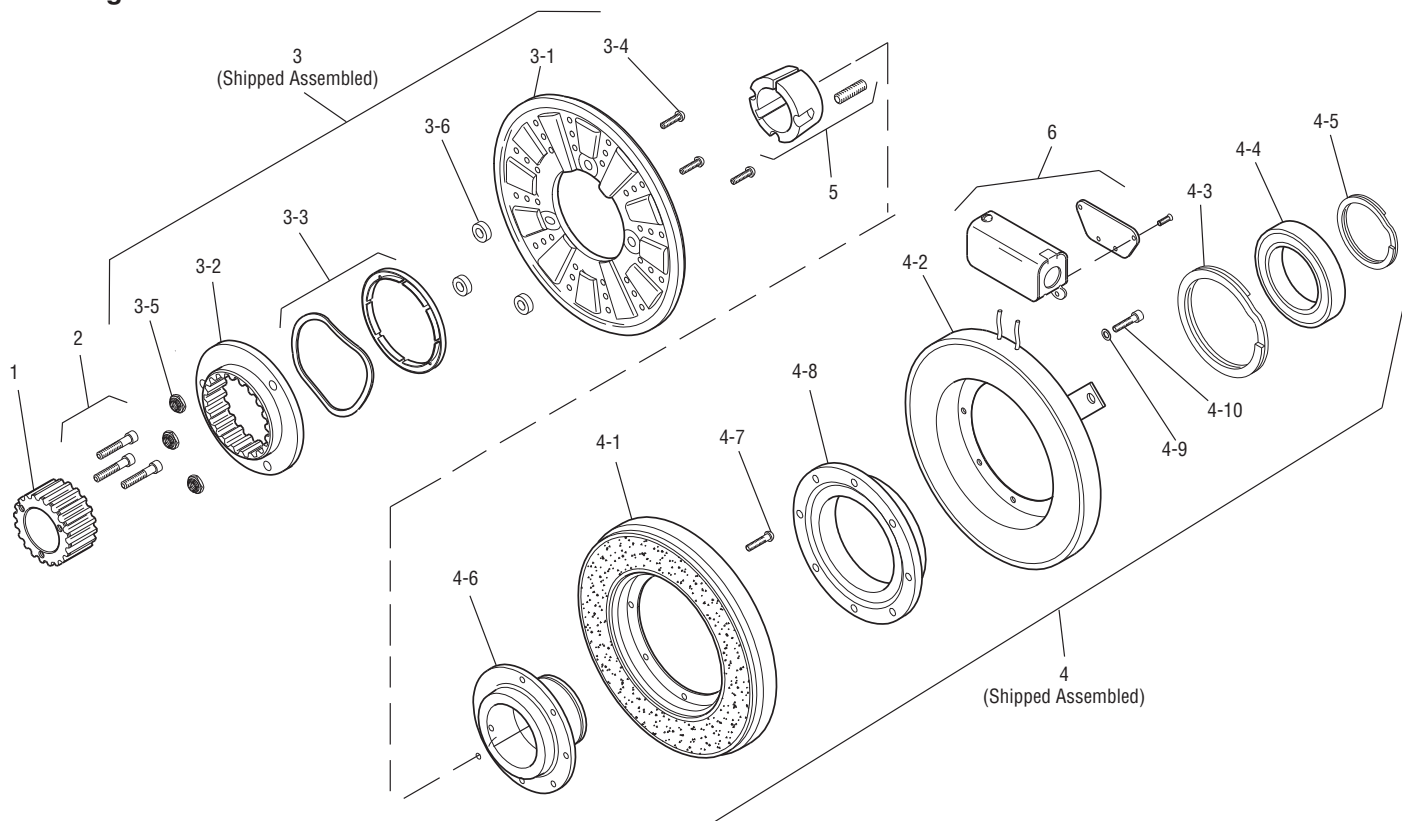

Item	Description	Part Number	Qty.
1	Splined Hub	540-0148	1
2	Accessory Mounting	5202-101-001	1
3	Armature & Adapter Assembly	5203-111-001	1
3-1	Armature	5323-111-034	1
3-2	Splined Adapter	104-0010	1
3-3	Autogap Accessory	5323-101-002	1
3-4	Screw	797-0356	4
3-5	Locknut	661-0005	4
3-6	Spacer	266-0004	4
4	Field & Rotor Assembly		1
	6 Volt	5203-452-009	
	24 Volt	5203-452-011	
	90 Volt	5203-452-012	1
4-1	Rotor		1
	Standard Friction Material	5203-751-001	
	†Optional LK Facing	5203-751-004	
4-2	Field		1
	6 Volt	5203-451-034	
	24 Volt	5203-451-036	
	90 Volt	5203-451-037	
4-3	Retainer Ring	748-0119	1
4-4	Ball Bearing	166-1047	1

Item	Description	Part Number	Qty.
4-5	Retainer Ring	748-0011	1
4-6	Rotor Hub	540-1304	1
4-7	Buttonhead Screw	797-1261	8
4-8	Ring Adapter	748-0591	1
4-9	Lockwasher	950-0359	6
4-10	Sockethead Screw	797-0424	6
5	Bushing*	180-0185 to 180-0217	1
6	Conduit Box	5200-101-012	1

**How to Order:**

1. Specify Bore Size for Item 5.
2. Specify Voltage for Item 4.
3. See Controls Section.

**Example:**

SF-1225 Clutch per I-25622 - 90 Volt, 1" Bore

These units, when used in conjunction with the correct Warner Electric conduit box, meet the standards of UL508 and are listed under guide card #NMTR, file #59164. These units are CSA certified under file #LR11543.

\*See page 252 for specific part numbers.

Refer to Service Manual P-215.

†Optional LK facing available. For more information, see page 232.

**SF-1525 Flange Mounted**

See page 230 for details on Drive Pin mountings.

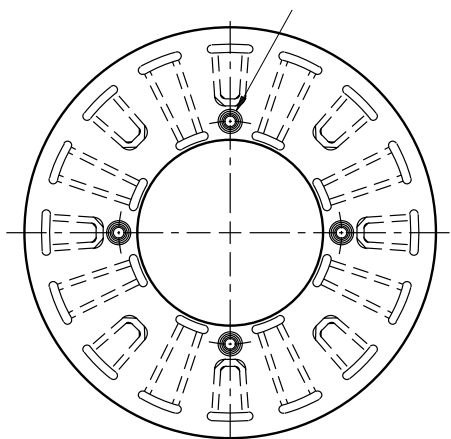

**ARMATURE VIEW**

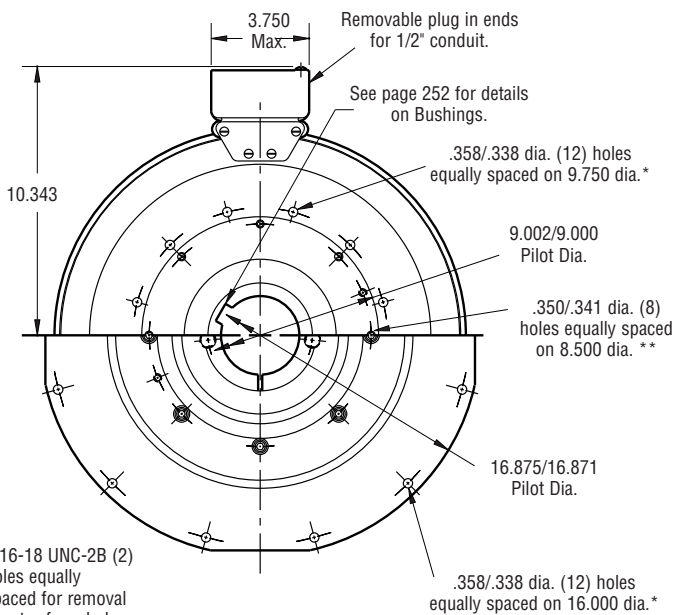
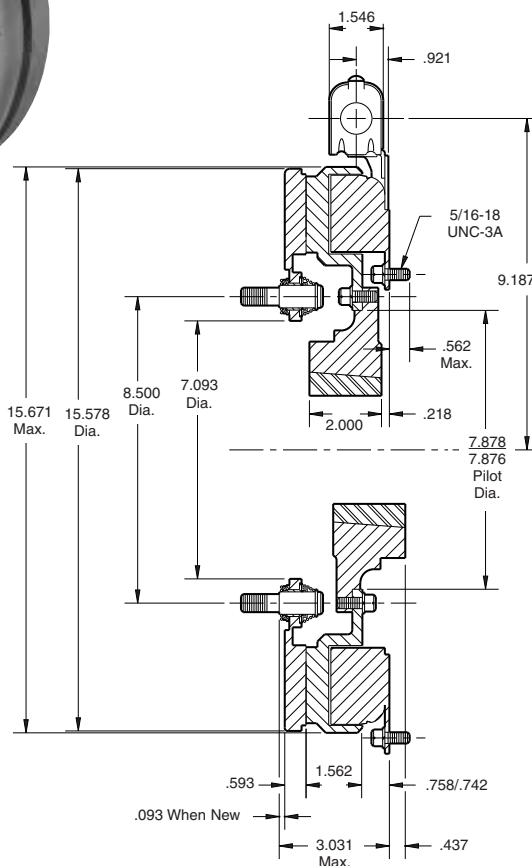

**FIELD VIEW**

**(Inside & Outside Mounted)**

**Customer Shall Maintain:**

1. Concentricity of field mounting pilot diameter with rotor mounting shaft within .006 T.I.R.
2. Squareness of field mounting face with rotor mounting shaft within .006 T.I.R. measured at field mounting bolt circle.
3. Rotor mounting shaft concentric with armature center of rotation within .006 T.I.R.
4. Armature hub pilot diameter to be concentric with armature center of rotation within .010 T.I.R.

**When Hub is Furnished by customer:**

Rotor mounting pilot diameter must be concentric with rotor mounting shaft within .006 T.I.R.

\* Mounting holes are within .010 of true position relative to pilot diameter.  
 \*\* Mounting holes are within .008 of true position relative to pilot diameter.

Shaft Size	.937 – 3.000
Static Torque	700 lb.ft.
Maximum Speed	2,000 rpm
Standard Voltage	D.C. 6, 24, 90

All dimensions are nominal unless otherwise noted.

Information on inertia and weights begins on page 239. Coil data is on pages 250 and 251.



Drawing I-25625

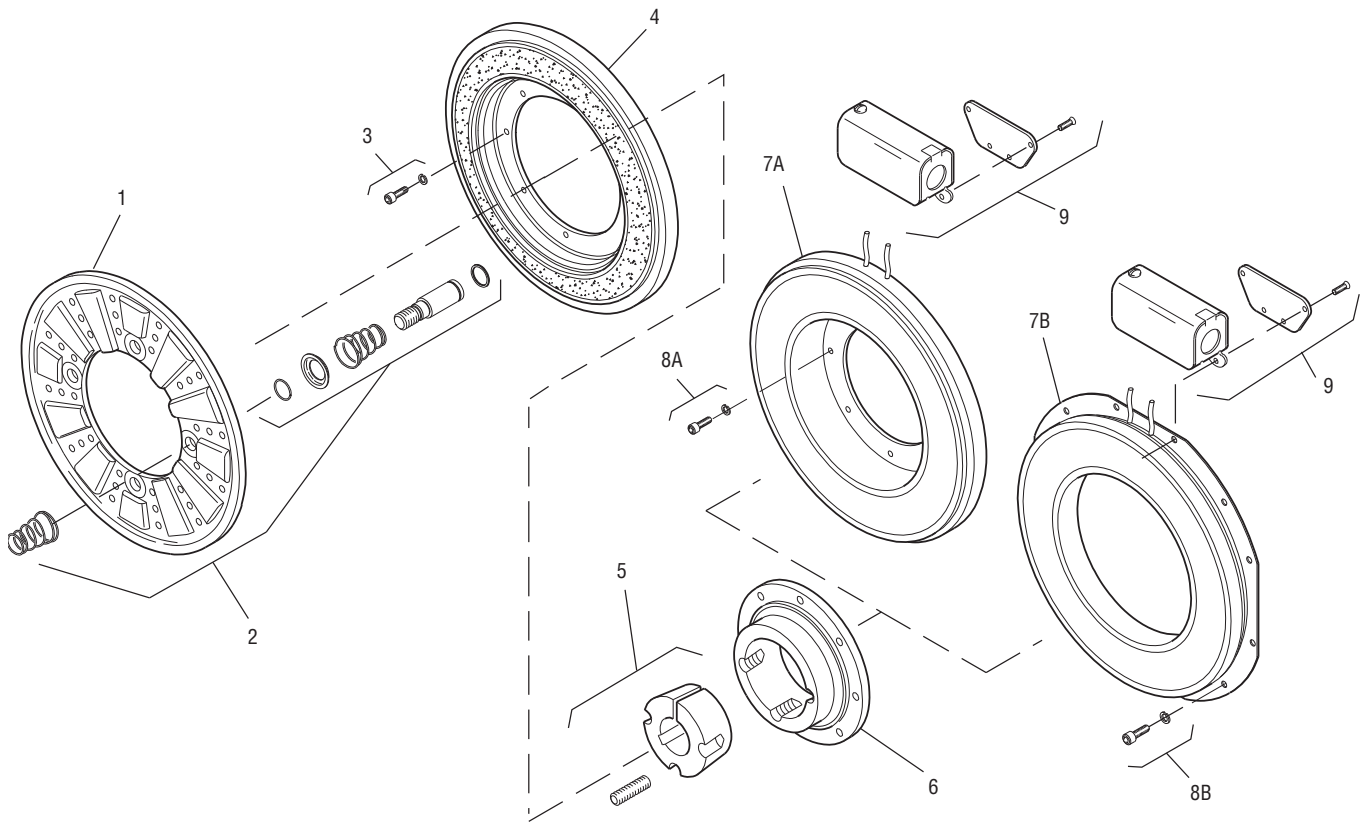

Item	Description	Part Number	Qty.
1	Armature	5304-111-004	1
2	Autogap Accessory	5201-101-008	4
3	Mounting Accessory	5321-101-002	2
4	Rotor		1
	Standard Friction Material	5204-751-002	
	†Optional LK Facing	5204-751-004	
5	Bushing*		1
	15/16" to 3" Bore	180-0223 to 180-0256	
6	Rotor Hub	540-0004	1
7A	Field - Inside Mounted		1
	6 Volt	5204-451-013	
	24 Volt	5204-451-015	
	90 Volt	5204-451-016	
7B	Field - Outside Mounted		1
	6 Volt	5204-451-055	
	24 Volt	5204-451-056	
	90 Volt	5204-451-057	
8A	Mounting Accessory - I.M.	5321-101-001	2

Item	Description	Part Number	Qty.
8B	Mounting Accessory - O.M.	5321-101-001	2
9	Conduit Box	5200-101-012	1

**How to Order:**

1. Specify Bore Size for Item 5.
2. Specify Voltage for Item 7A or 7B.
3. Specify Inside Mounted for Items 7A and 8A or Outside Mounted for Items 7B and 8B.
4. See Controls Section.

**Example:**

SF-1525 Clutch per I-25625 - 90 Volt, 2" Bore, Inside Mounted.

These units, when used in conjunction with the correct Warner Electric conduit box, meet the standards of UL508 and are listed under guide card #NMTR, file #59164. These units are CSA certified under file #LR11543.

\*See page 252 for specific part numbers.

Refer to Service Manual P-215.

†Optional LK facing available. For more information, see page 232.

**SF-1525 Flange Mounted**

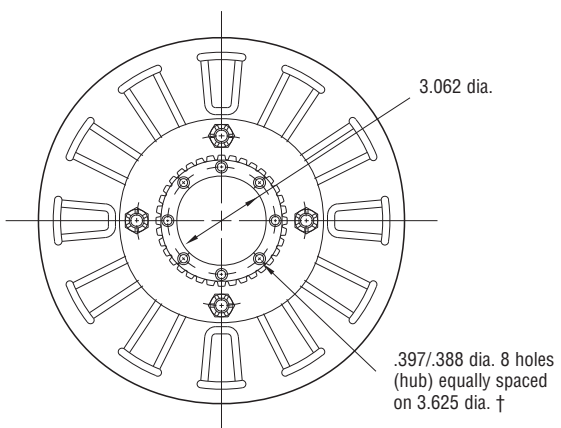
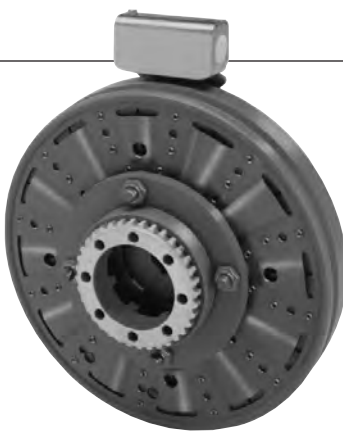

**ARMATURE VIEW**

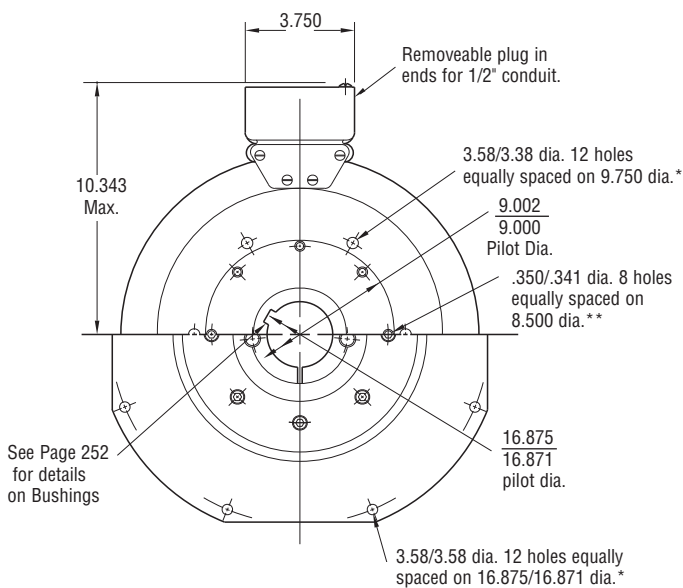

**FIELD VIEW  
(Inside & Outside Mounted)**

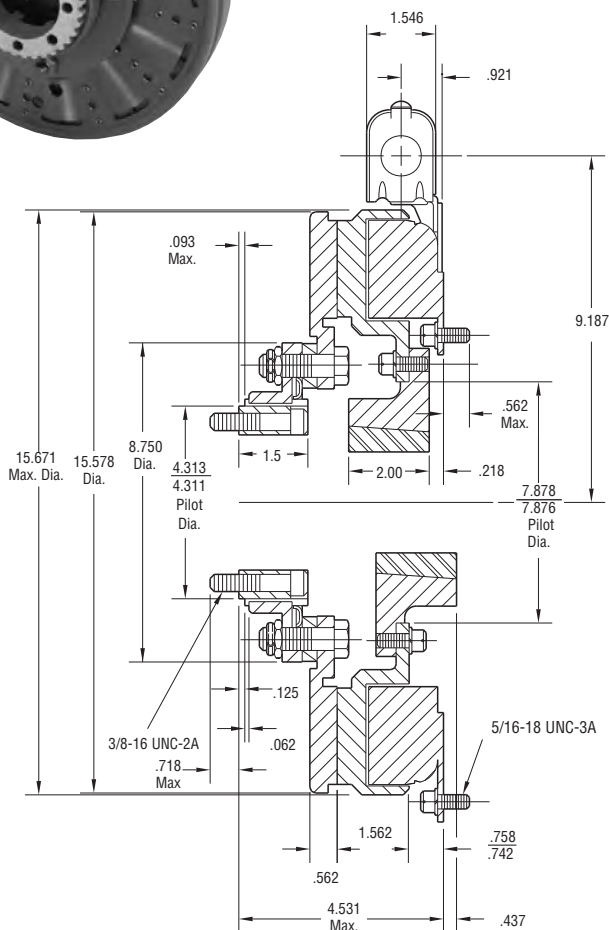

\* Mounting holes are within .010 of true position relative to pilot diameter.

\*\* Mounting holes are within .008 of true position relative to pilot diameter.

† Mounting holes are within .003 of true position relative to pilot diameter.

**Customer Shall Maintain:**

1. Concentricity of field mounting pilot diameter with rotor mounting shaft within .006 T.I.R.
2. Squareness of field mounting face with rotor mounting shaft within .006 T.I.R. measured at field mounting bolt circle.
3. Armature hub pilot diameter to be concentric with armature center of rotation within .010 T.I.R.

**When Hub is Furnished by customer:**

Rotor mounting pilot diameter must be concentric with rotor mounting shaft within .006 T.I.R.

Shaft Size	.937 – 3.000
Static Torque	700 lb.ft.
Maximum Speed	2,000 rpm
Standard Voltage	D.C. 6, 24, 90

All dimensions are nominal unless otherwise noted.

Information on inertia and weights begins on page 239. Coil data is on pages 250 and 251.





SF-1525 Flange Mounted

Drawing I-25626

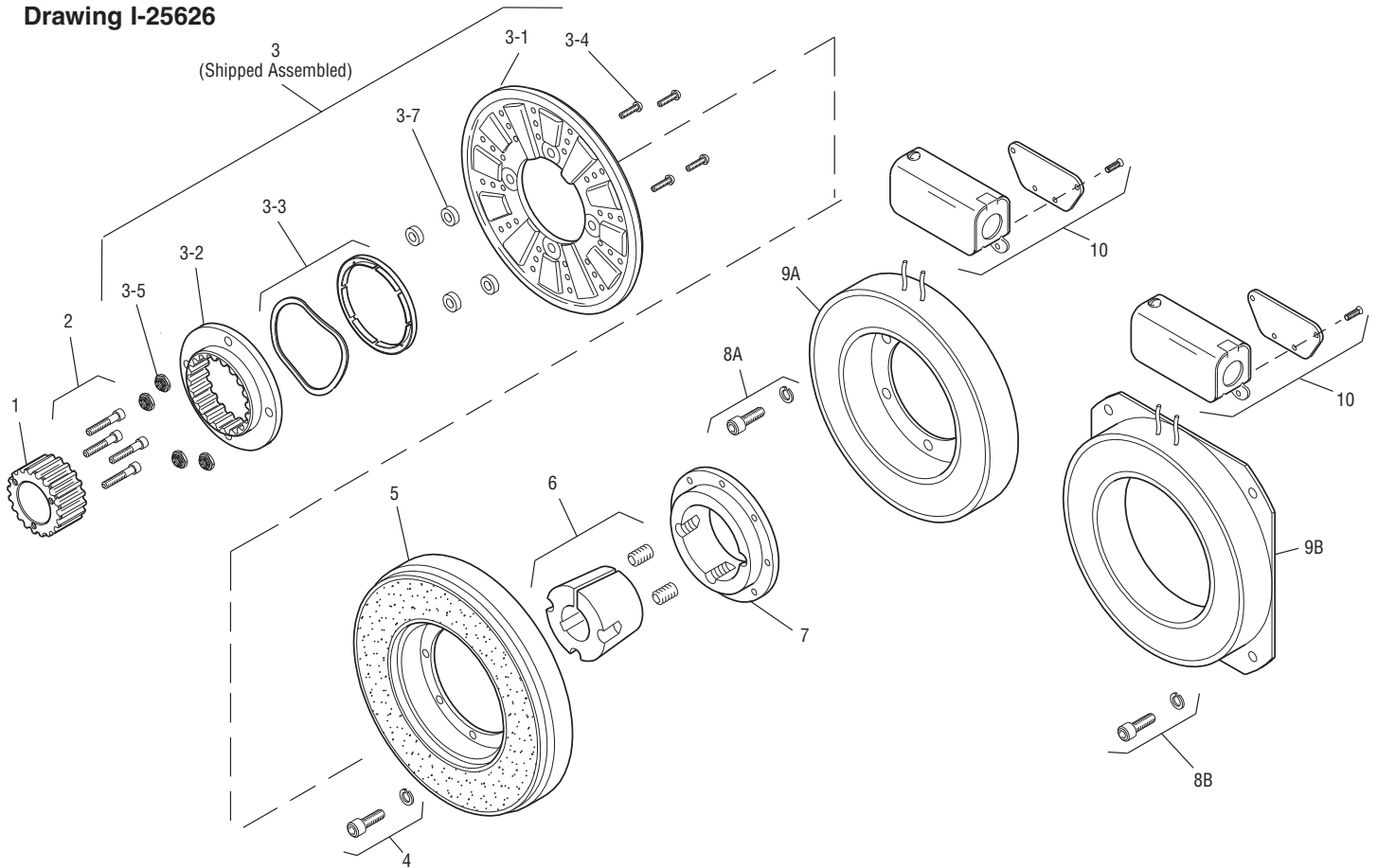

Item	Description	Part Number	Qty.
1	Splined Hub	540-0148	1
2	Mounting Accessory	5202-101-001	1
3	Armature and Splined Adapter	5204-111-004	1
3-1	Armature	5324-111-034	1
3-2	Splined Adapter	104-0011	1
3-3	Autogap Accessory	5323-101-002	1
3-4	Screw	797-0342	8
3-5	Locknut	661-0004	8
3-6	Retainer Plate	686-0003	1
3-7	Spacer	748-0333	8
4	Mounting Accessory	5321-101-002	2
5	Rotor		1
	Standard Friction Material	5204-751-002	
	†Optional LK Facing	5204-751-004	
6	Bushing, Taperlock*	180-0223 to 180-0256	1
7	Rotor Hub	540-0004	1
8A	Mounting Accessory, I.M.	5321-101-001	2
8B	Mounting Accessory, O.M.	5321-101-002	2
9A	Field, Inside Mtd.		1
	6 Volt	5204-451-013	
	24 Volt	5204-451-015	
	90 Volt	5204-451-016	

Item	Description	Part Number	Qty.
9B	Field, Outside Mtd.		1
	6 Volt	5204-451-055	
	24 Volt	5204-451-056	
	90 Volt	5204-451-057	
10	Conduit Box	5200-101-012	1

**How to Order:**

1. Specify Bore Size for Item 6.
2. Specify Voltage for Item 9A or 9B.
3. Specify Inside Mounted for Items 8A and 9A or Outside Mounted for Items 8B and 9B.
4. See Controls Section.

**Example:**

SF-1525 Clutch per I-25626 - 90 Volt, 2" Bore, Inside Mounted.

These units, when used in conjunction with the correct Warner Electric conduit box, meet the standards of UL508 and are listed under guide card #NMTR, file #59164. These units are CSA certified under file #LR11543.

\*See page 252 for specific part numbers.

Refer to Service Manual P-215.

†Optional LK facing available. For more information, see page 232.

**SF-1525 Bearing Mounted**

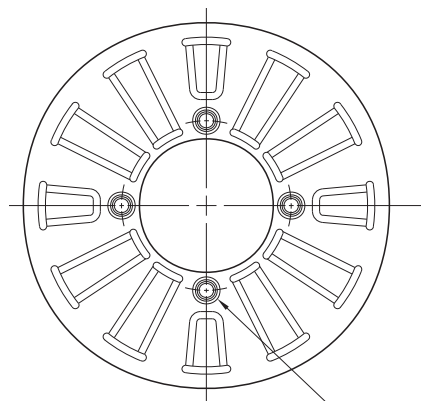
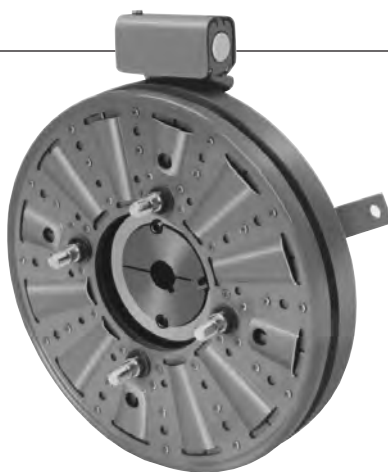

See page 230 for details on Drive Pin mountings.

**ARMATURE VIEW**

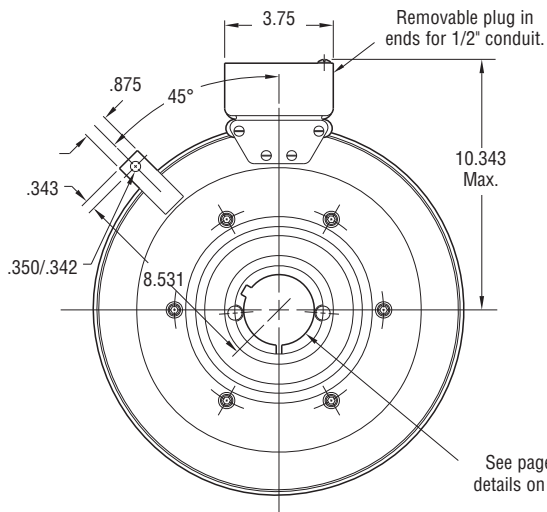

See page 252 for details on Bushings.

**FIELD VIEW**

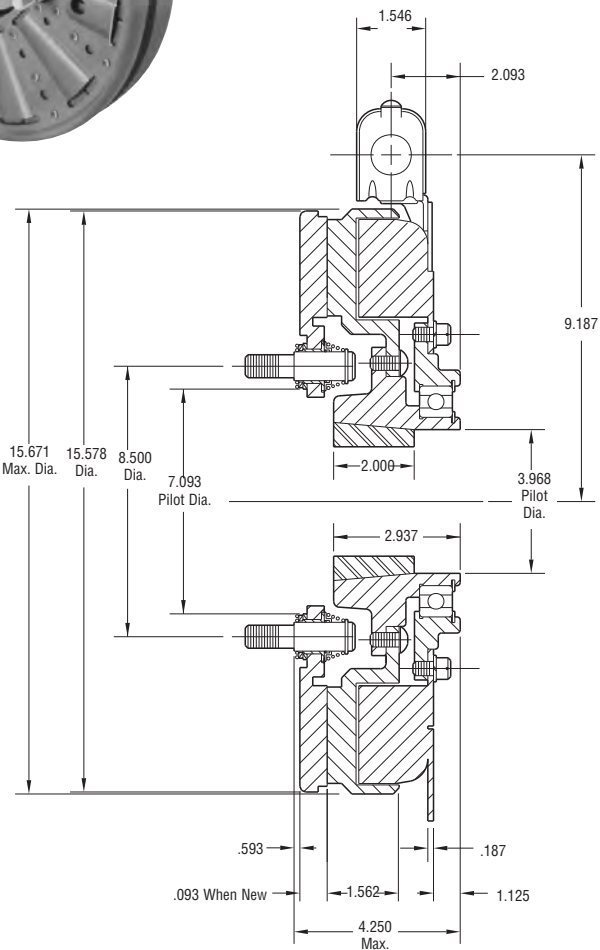

Shaft Size	.937 – 3.000
Static Torque	700 lb.ft.
Maximum Speed	1,800 rpm
Standard Voltage	D.C. 6, 24, 90

All dimensions are nominal unless otherwise noted.

Information on inertia and weights begins on page 239. Coil data is on pages 250 and 251.



Drawing I-25639

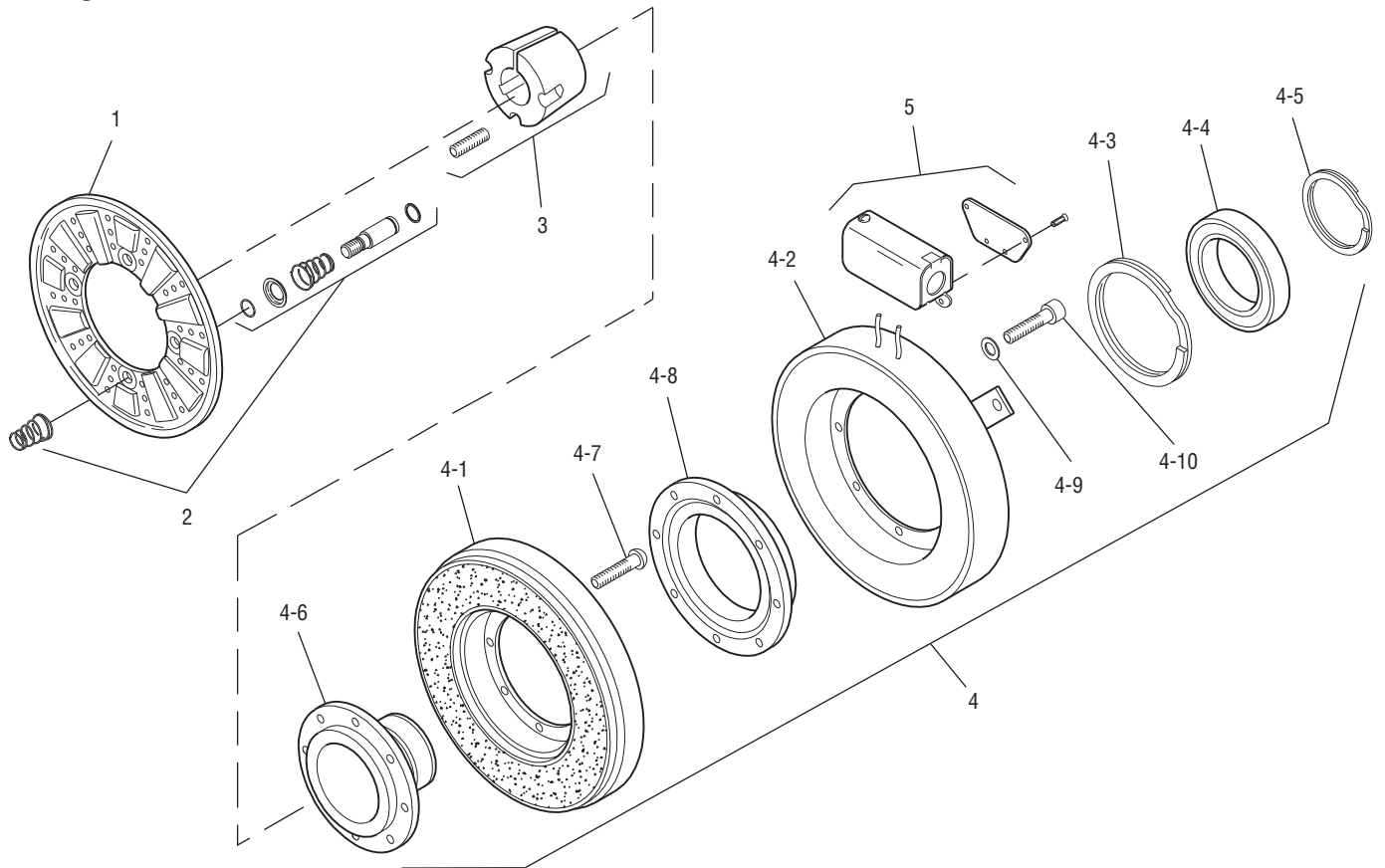

Item	Description	Part Number	Qty.
1	Armature	5304-111-004	1
2	Autogap Accessory	5201-101-008	4
3	Bushing*		1
	15/16" to 3" Bore	180-0223 to 180-0256	
4	Field and Rotor Assembly		1
	6 Volt	5204-452-009	
	24 Volt	5204-452-011	
	90 Volt	5204-452-012	
4-1	Rotor		1
	Standard Friction Material	5204-751-002	
	†Optional LK Facing	5204-751-004	
4-2	Field		1
	6 Volt	5204-451-084	
	24 Volt	5204-451-086	
	90 Volt	5204-451-087	
4-3	Retainer Ring	748-0114	1
4-4	Ball Bearing	166-0163	1
4-5	Retainer Ring	748-0583	1
4-6	Rotor Hub	540-1306	1

Item	Description	Part Number	Qty.
4-7	Buttonhead Capscrew	797-1261	8
4-8	Ring Adapter	748-1048	1
4-9	Lockwasher	950-0359	6
4-10	Sockethead Capscrew	797-0424	6
5	Conduit Box	5200-101-012	1

**How to Order:**

1. Specify Bore Size for Item 3.
2. Specify Voltage for Item 4.
3. See Controls Section.

**Example:**

SF-1525 Clutch per I-25639 - 90 Volt, 1" Bore.

These units, when used in conjunction with the correct Warner Electric conduit box, meet the standards of UL508 and are listed under guide card #NMTR, file #59164. These units are CSA certified under file #LR11543.

\*See page 252 for specific part numbers.

Refer to Service Manual P-215.

†Optional LK facing available. For more information, see page 232.

**SF-1525 Bearing Mounted**

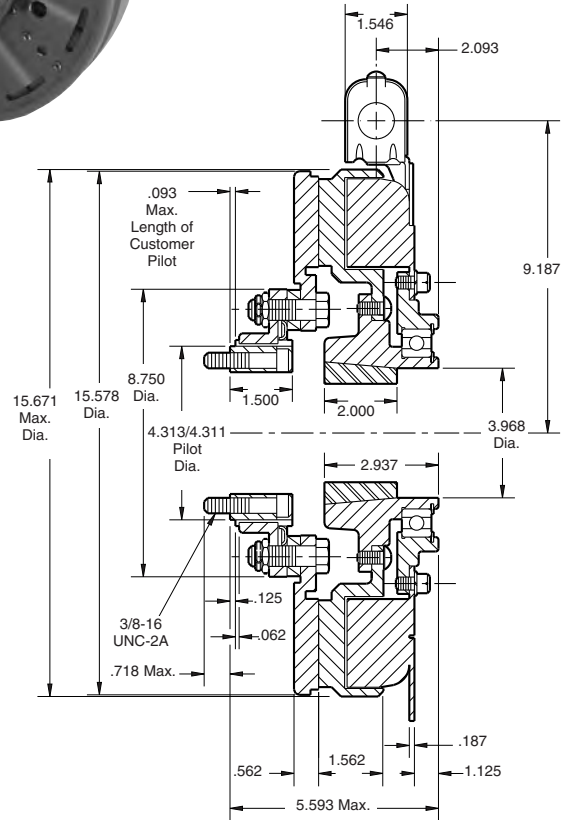
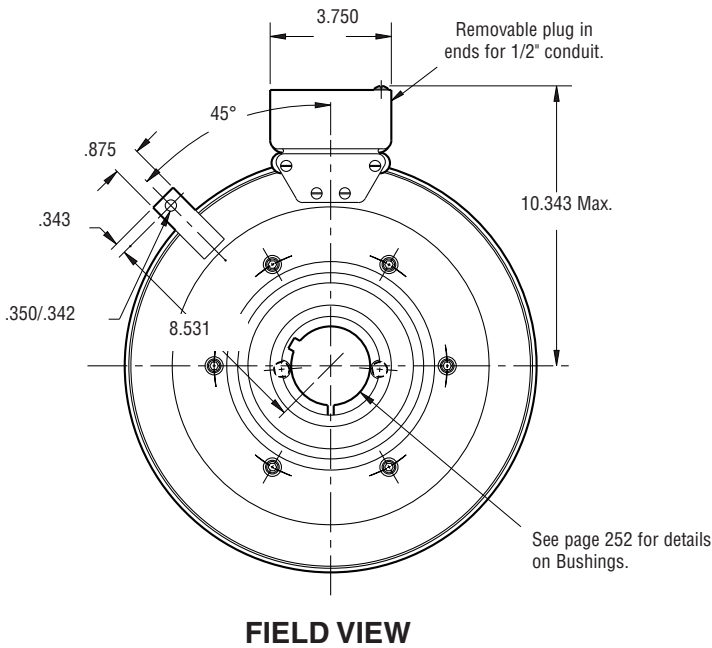
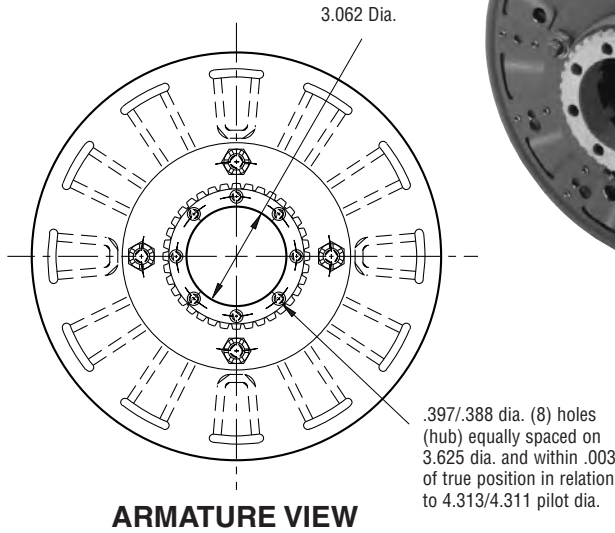

Shaft Size	.937 – 3.000
Static Torque	700 lb.ft.
Maximum Speed	1,800 rpm
Standard Voltage	D.C. 6, 24, 90

All dimensions are nominal unless otherwise noted.

Information on inertia and weights begins on page 239. Coil data is on pages 250 and 251.

**Customer Shall Maintain:**

1. Armature hub pilot diameter to be concentric with field and rotor mounting shaft within .010 T.I.R.



SF-1525 Bearing Mounted

Drawing I-25640

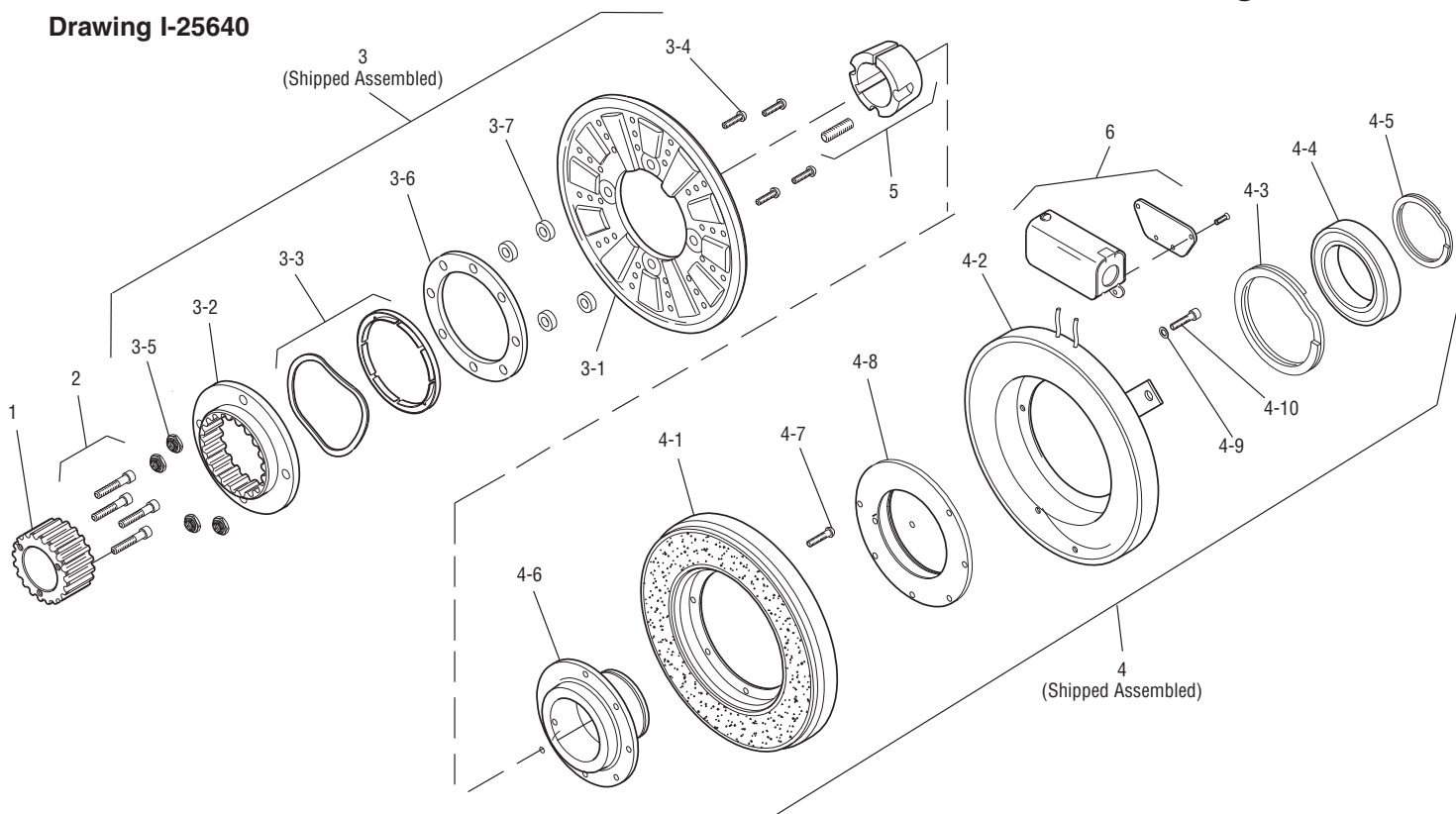

Item	Description	Part Number	Qty.
1	Splined Hub	540-0148	1
2	Accessory Mounting	5202-101-001	1
3	Armature & Adapter Assembly	5204-111-004	1
3-1	Armature	5324-111-034	1
3-2	Splined Adapter	104-0011	1
3-3	Autogap Accessory	5323-101-002	1
3-4	Screw	797-0342	8
3-5	Locknut	661-0004	8
3-6	Retainer Plate	686-0003	1
3-7	Spacer	748-0333	8
4	Field & Rotor Assembly		1
	6 Volt	5204-452-009	
	24 Volt	5204-452-011	
	90 Volt	5204-452-012	
4-1	Rotor		1
	Standard Friction Material	5204-751-002	
	†Optional LK Facing	5204-751-004	
4-2	Field		1
	6 Volt	5204-451-084	
	24 Volt	5204-451-086	
	90 Volt	5204-451-087	
4-3	Retainer Ring	748-0114	1

Item	Description	Part Number	Qty.
4-4	Ball Bearing	166-0163	1
4-5	Retainer Ring	748-0583	1
4-6	Rotor Hub	540-1306	1
4-7	Buttonhead Screw	797-1261	8
4-8	Ring Adapter	748-1048	1
4-9	Lockwasher	950-0359	6
4-10	Sockethead Screw	797-0424	6
5	Bushing*	180-0223 to 180-0256	1
6	Conduit Box	5200-101-012	1

**How to Order:**

1. Specify Bore Size for Item 5.
2. Specify Voltage for Item 4.
3. See Controls Section.

**Example:**

SF-1525 Clutch per I-25640 - 90 Volt, 1" Bore

These units, when used in conjunction with the correct Warner Electric conduit box, meet the standards of UL508 and are listed under guide card #NMTR, file #59164. These units are CSA certified under file #LR11543.

\*See page 252 for specific part numbers.

Refer to Service Manual P-215.

†Optional LK facing available. For more information, see page 232.

# Clutch, Hi-Torque

## SF-1525 H.T. Flange Mounted

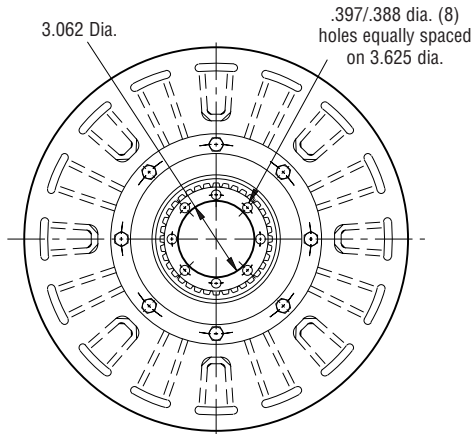

**ARMATURE VIEW**

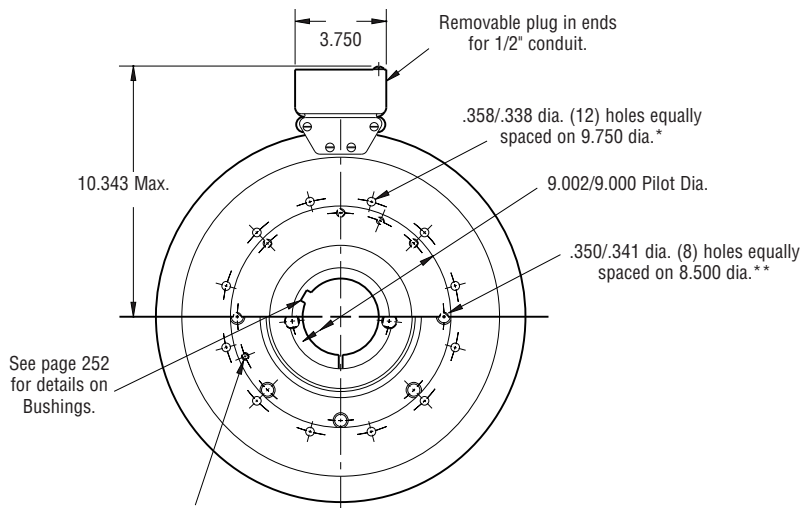

**FIELD VIEW**

See page 252 for details on Bushings.

5/16-18 UNC-2B (2) holes equally spaced for removal of rotor from hub.

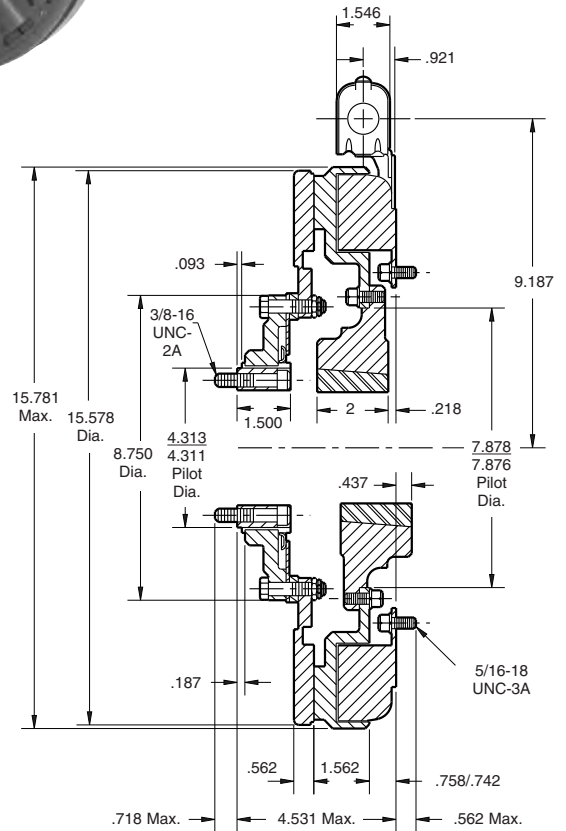

### Customer Shall Maintain:

1. Concentricity of field mounting pilot diameter with rotor mounting shaft within .006 T.I.R.
2. Squareness of field mounting face with rotor mounting shaft within .006 T.I.R. measured at field mounting bolt circle.
3. Rotor mounting shaft concentric with armature center of rotation within .006 T.I.R.
4. Armature hub pilot diameter to be concentric with armature center of rotation within .010 T.I.R.

### When Hub is Furnished by Customer:

Rotor mounting pilot diameter must be concentric with rotor mounting shaft within .006 T.I.R.

\* Mounting holes are within .010 of true position relative to pilot diameter.

\*\* Mounting holes are within .008 of true position relative to pilot diameter.

Shaft Size	.937- 3.000
Static Torque	1,350 lb.ft.
Maximum Speed	2,000 rpm
Standard Voltage	D.C. 6, 90

All dimensions are nominal unless otherwise noted.

Information on inertia and weights begins on page 239. Coil data is on pages 250 and 251.



Drawing I-25627

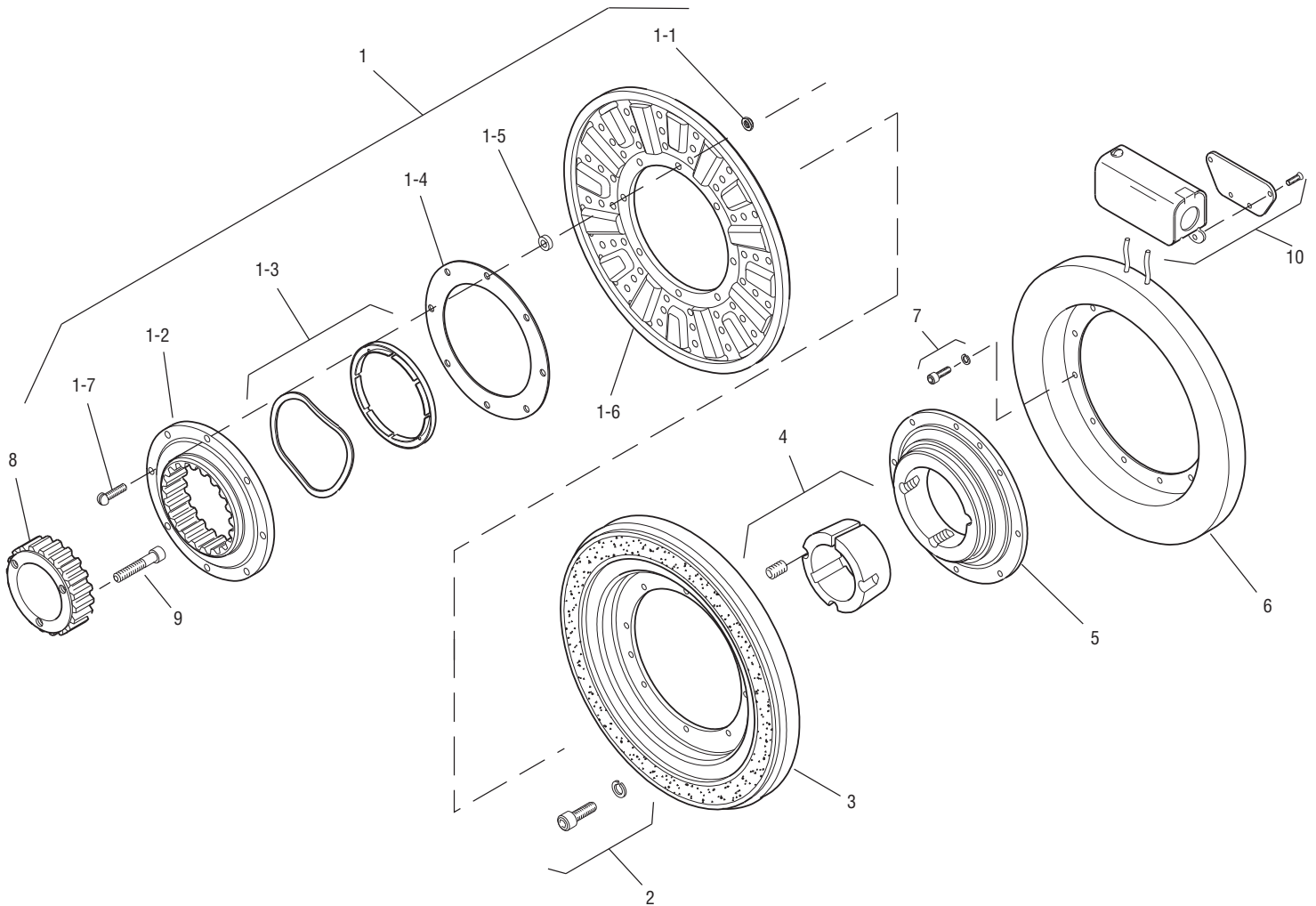

Item	Description	Part Number	Qty.
1	Armature Assembly	5204-111-004	1
1-1	Locknut	661-0004	8
1-2	Splined Adapter	104-0011	1
1-3	Autogap Accessory	5323-101-002	1
1-4	Retainer Plate	686-0003	1
1-5	Spacer	748-0333	8
1-6	Armature	5324-111-034	1
1-7	Screw	797-0342	8
2	Mounting Accessory	5321-101-002	2
3	Rotor	5204-751-001	1
4	Bushing*		
	15/16" to 3" Bore	180-0223 to 180-0256	1
5	Rotor Hub	540-0004	1
6	Field - Inside Mounted		1
	6 Volt	5204-451-005	
	90 Volt	5204-451-006	

Item	Description	Part Number	Qty.
7	Mounting Accessory - I.M.	5321-101-001	2
8	Splined Hub	540-0148	1
9	Mounting Accessory	5202-101-001	1
10	Conduit Box	5200-101-012	1

**How to Order:**

1. Specify Bore Size of Item 4.
2. See Controls Section.

**Example:**

SF-1525 Clutch, Hi-Torque, per I-25627 - 90 Volt, 2" Bore

These units, when used in conjunction with the correct Warner Electric conduit box, meet the standards of UL508 and are listed under guide card #NMTR, file #59164. These units are CSA certified under file #LR11543.

\*See page 252 for specific part numbers.

Refer to Service Manual P-215.

# Clutch, Hi-Torque

## SF-1525 H.T. Bearing Mounted

.397/.388 dia. (8) holes (hub) equally spaced on 3.625 dia. and within .003 of true position relative to 4.313/4.311 pilot diameter.

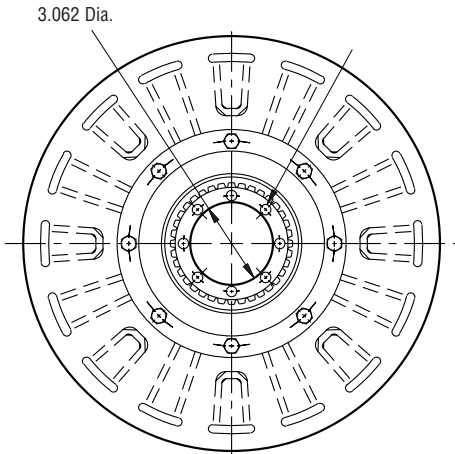

**ARMATURE VIEW**

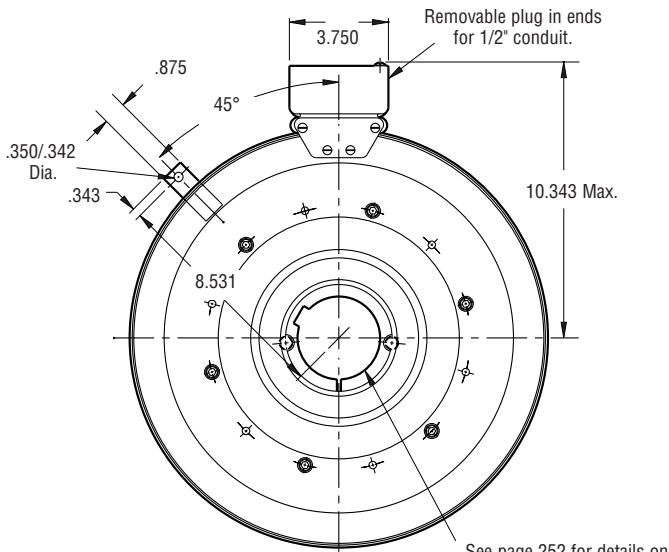

**FIELD VIEW**

### Customer Shall Maintain:

1. Armature hub pilot diameter to be concentric with field and rotor mounting shaft within .010 T.I.R.

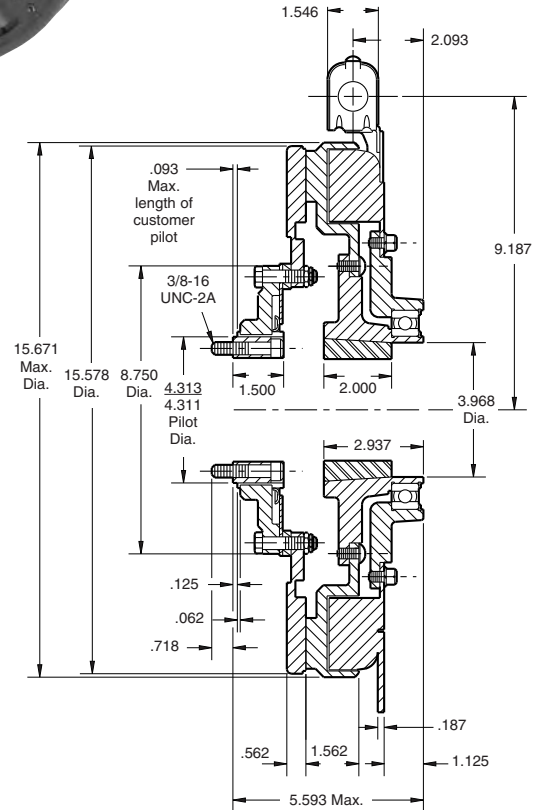

Shaft Size	.937– 3.000
Static Torque	1,350 lb.ft.
Maximum Speed	1,800 rpm
Standard Voltage	D.C. 90

All dimensions are nominal unless otherwise noted.

Information on inertia and weights begins on page 239. Coil data is on pages 250 and 251.





Drawing I-25643

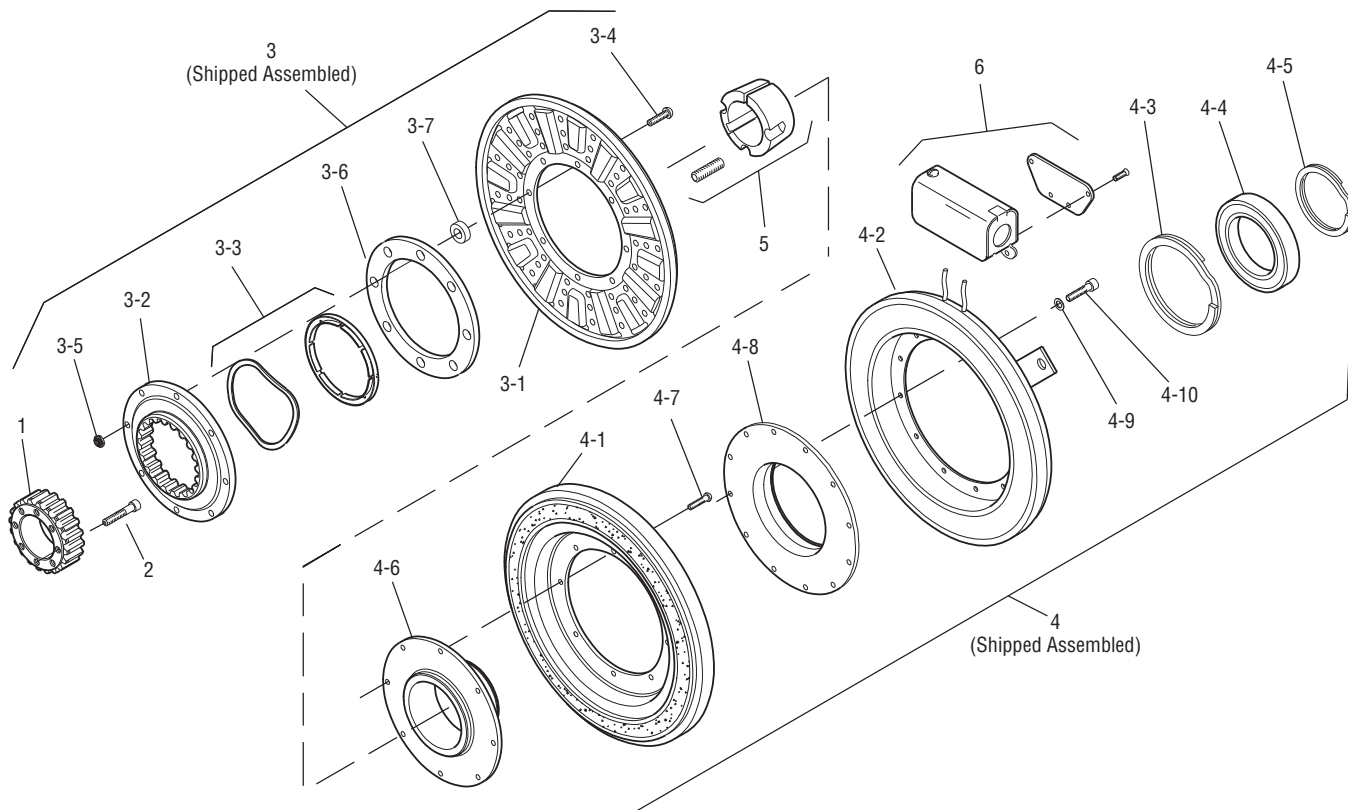

Item	Description	Part Number	Qty.
1	Splined Hub	540-0148	1
2	Accessory, Mounting	5202-101-001	1
3	Armature & Adapter Assembly	5204-111-004	1
3-1	Armature	5324-111-034	1
3-2	Splined Adapter	104-0011	1
3-3	Autogap Accessory	5323-101-002	1
3-4	Screw	797-0342	8
3-5	Locknut	661-0004	8
3-6	Retainer Plate	686-0003	1
3-7	Spacer	748-0333	8
4	Field & Rotor Assembly		1
	90 Volt	5204-452-015	
4-1	Rotor	5204-751-001	1
4-2	Field		1
	90 Volt	5204-451-090	
4-3	Retainer Ring	748-0114	1
4-4	Ball Bearing	166-0163	1
4-5	Retainer Ring	748-0583	1
4-6	Rotor Hub	540-1306	1

Item	Description	Part Number	Qty.
4-7	Buttonhead Screw	797-1261	8
4-8	Ring Adapter	748-1048	1
4-9	Lockwasher	950-0359	6
4-10	Sockethead Screw	797-0424	6
5	Bushing*	180-0223 to 180-0256	1
6	Conduit Box	5200-101-012	1

### How to Order:

1. Specify Bore Size for Item 5.
2. Specify Voltage for Item 4.
3. See Controls Section.

### Example:

SF-1525 Clutch Hi-Torque per I-25643 - 90 Volt, 1" Bore

These units, when used in conjunction with the correct Warner Electric conduit box, meet the standards of UL508 and are listed under guide card #NMTR, file #59164. These units are CSA certified under file #LR11543.

\*See page 252 for specific part numbers.

Refer to Service Manual P-215.

# Clutch

## PC-500



See page 230 for details on Drive Pin mountings.

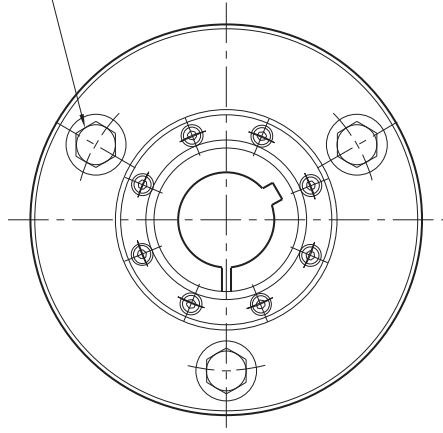

**ARMATURE VIEW**

1/2-14 NPSM Am. std. straight pipe tap.

See page 252 for details on Bushings.

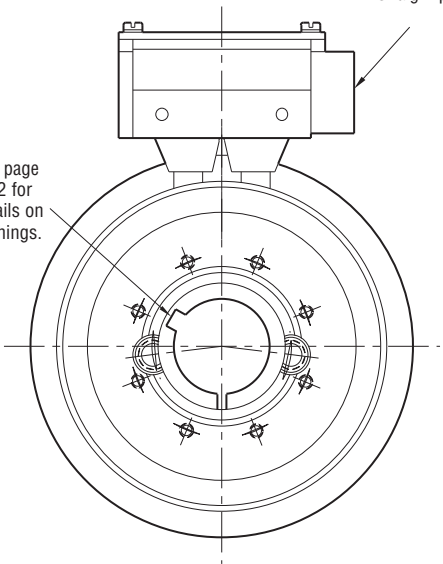

**MAGNET VIEW**

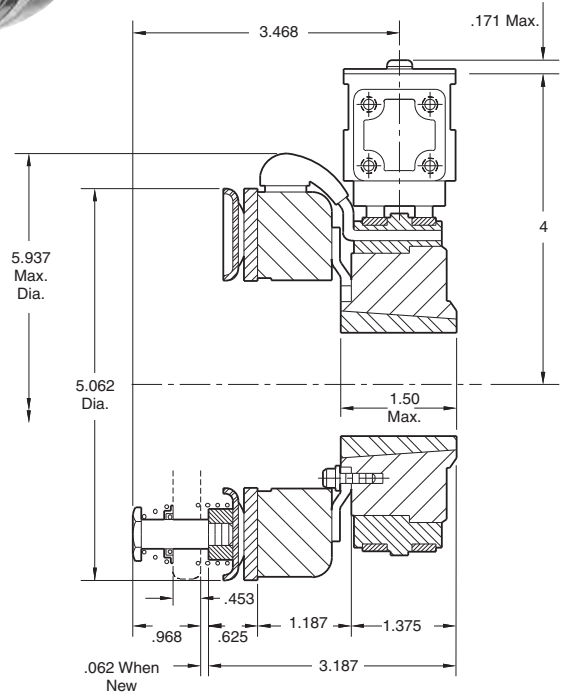

Shaft Size	.500 – 1.250
Static Torque	40 lb.ft.
Maximum Speed	5,400 rpm
Standard Voltage	D.C. 6, 24, 90

All dimensions are nominal unless otherwise noted.

Information on inertia and weights begins on page 239. Coil data is on pages 250 and 251.

### Customer Shall Maintain:

1. Armature mounting to be concentric with magnet hub assembly within .006 T.I.R.



**Drawing I-25716**

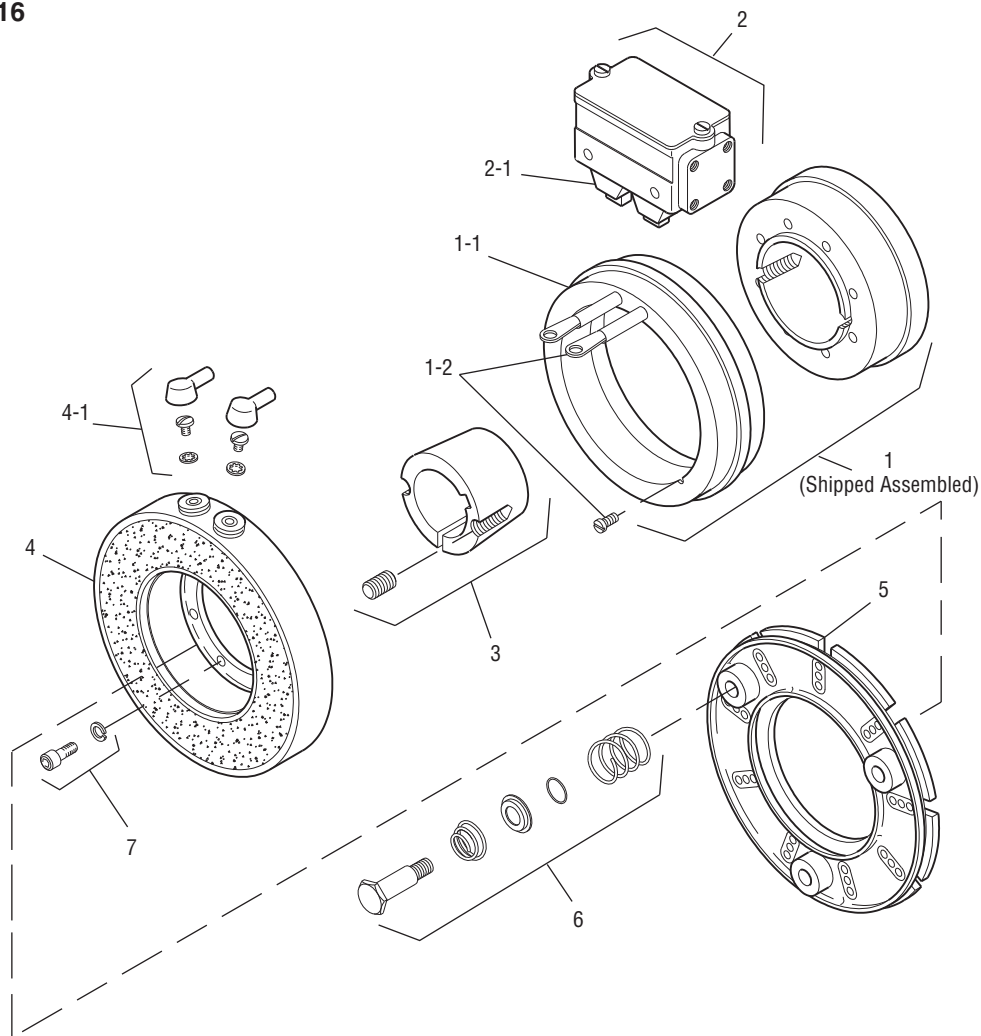

Item	Description	Part Number	Qty.
1	Magnet Hub	5300-541-001	1
1-1	Collector Ring	5300-749-001	1
1-2	Collector Ring Mounting Acc.	5300-101-002	1
2	Brushholder	5300-178-001	1
2-1	Brush	176-0001	4
3	Bushing*		1
	1/2" to 1-1/4" Bore	180-0116 to 180-0128	
4	Magnet		1
	6 Volt.	5300-631-002	
	24 Volt	5300-631-003	
	90 Volt	5300-631-005	
4-1	Terminal Accessory	5311-101-001	1
5	Armature	5300-111-002	1
6	Autogap Accessory	5200-101-009	3
7	Mounting Accessory	5102-101-001	2

**How to Order:**

1. Specify Bore Size for Item 3.
2. Specify Voltage for Item 4.
3. See Controls Section.

**Example:**

PC-500 Clutch per I-25716 - 90 Volt  
3/4" Bore

These units, when used in conjunction with the correct Warner Electric conduit box, meet the standards set of UL508 and are listed under guide card #NMTR2, file #59164.

These units are CSA certified under file #LR11543.

\*See page 252 for specific part numbers.

Refer to Service Manual P-203.

# Clutch

## PC-825 Normal Duty

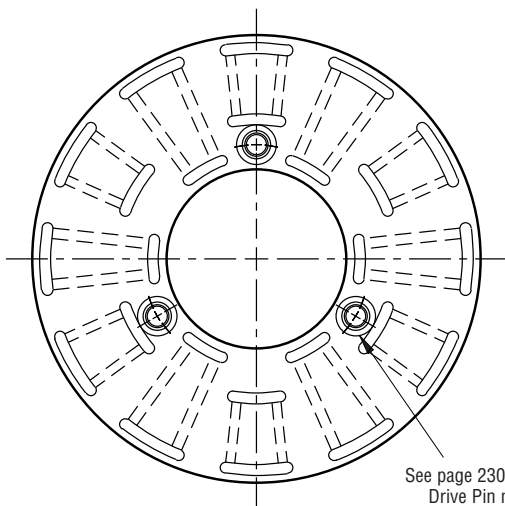

See page 230 for details on Drive Pin mountings.

**ARMATURE VIEW**

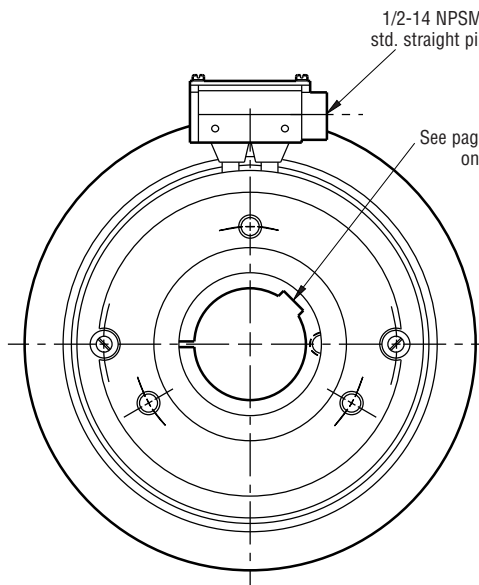

1/2-14 NPSM Am. std. straight pipe tap.

See page 252 for details on Bushings.

**COLLECTOR RING VIEW**

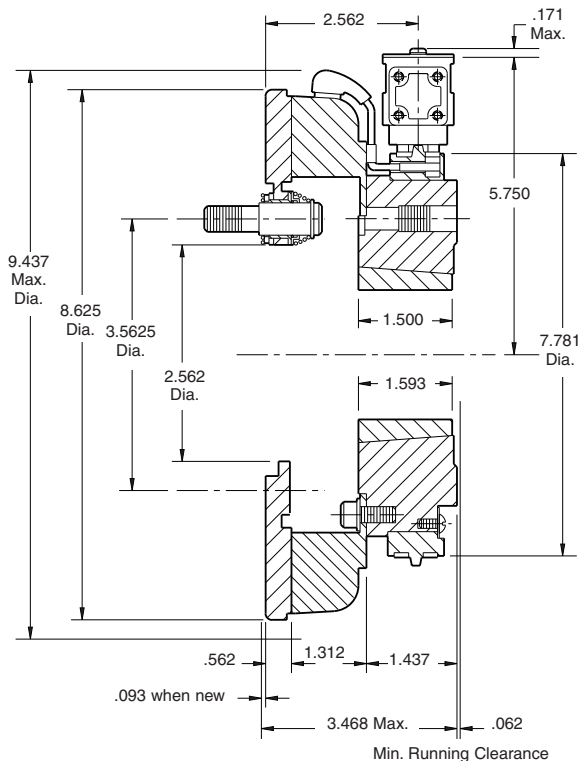

Shaft Size	.500 – 1.625
Static Torque	125 lb.ft.
Maximum Speed	4,000 rpm
Standard Voltage	D.C. 6, 24, 90

All dimensions are nominal unless otherwise noted.

Information on inertia and weights begins on page 239. Coil data is on pages 250 and 251.



Drawing I-25562

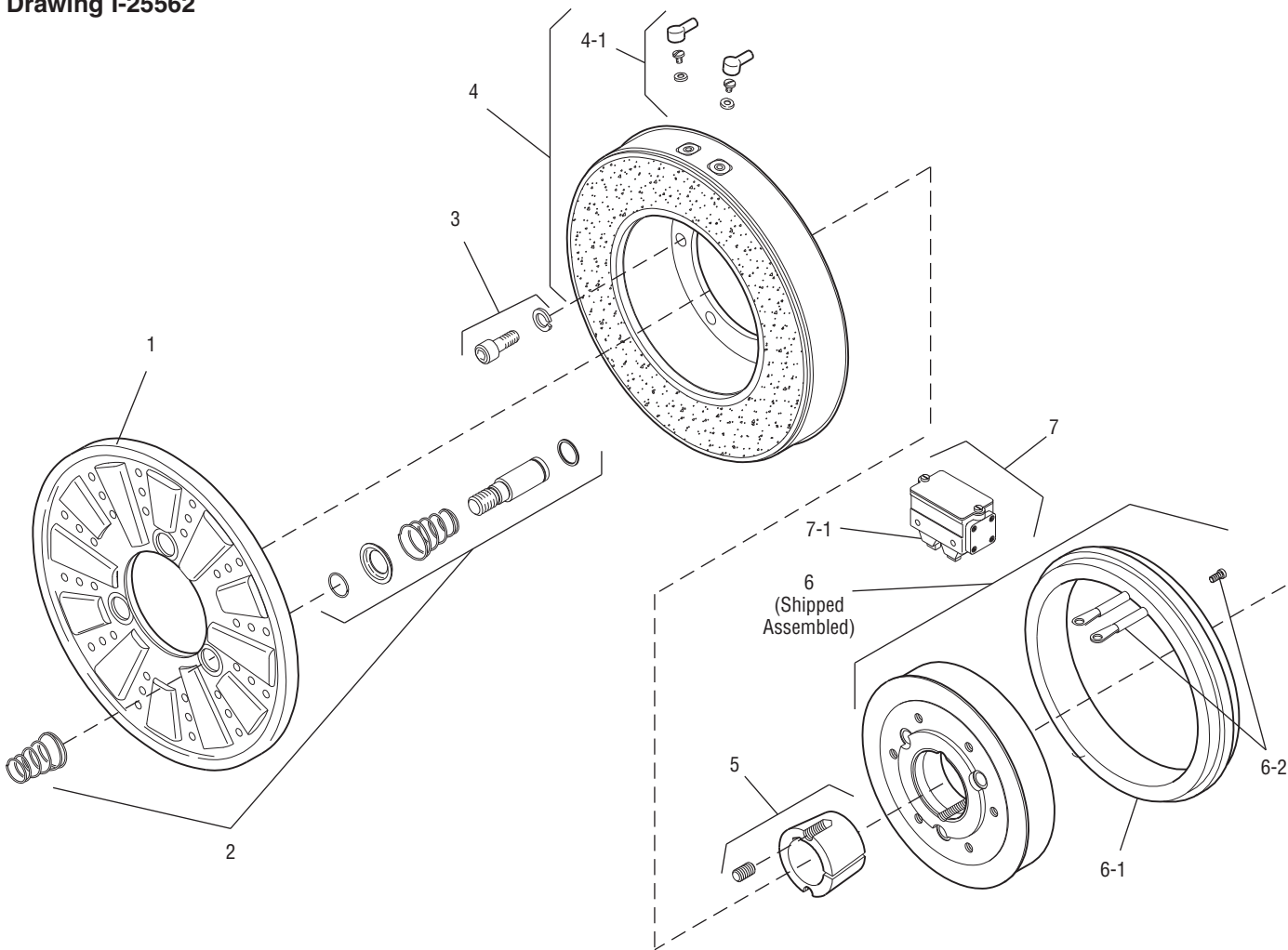

Item	Description	Part Number	Qty.
1	Armature	5301-111-018	1
2	Autogap Accessory	5201-101-008	3
3	Mounting Accessory	5321-101-001	1
4	Magnet		1
	6 Volt	5301-631-002	
	24 Volt	5301-631-004	
	90 Volt	5301-631-005	
	†90 Volt LK Facing	5301-631-011	
4-1	Terminal Accessory	5311-101-001	1
5	Bushing*		1
	1/2" to 1-5/8" Bore	180-0131 to 180-0149	
6	Magnet Hub		1
	Left Hand (shown)	5301-541-001	
	Right Hand	5301-541-002	
6-1	Collector Ring	5301-749-001	1
6-2	Collector Ring Accessory	5301-101-002	1
7	Brushholder	5300-178-001	1
7-1	Brush	176-0001	4

### How to Order:

1. Specify Voltage for Item 4.
2. Specify Bore Size for Item 5.
3. Specify left hand or right hand hub for Item 6. (Bushing enters from magnet side for L.H. hub and from hub side for R.H.)
4. See Controls Section.

### Example:

PC-825 Clutch per I-25562 - 90 Volt, L.H. hub, 1" Bore

These units meet the standards of UL508 and are listed under guide card #NMTR2, file #59164.

These units are CSA certified under file #LR11543.

\*See page 252 for specific part numbers.

Refer to Service Manual P-206.

†Optional LK facing available. For more information, see page 232.

# Clutch

## PC-825 Heavy Duty

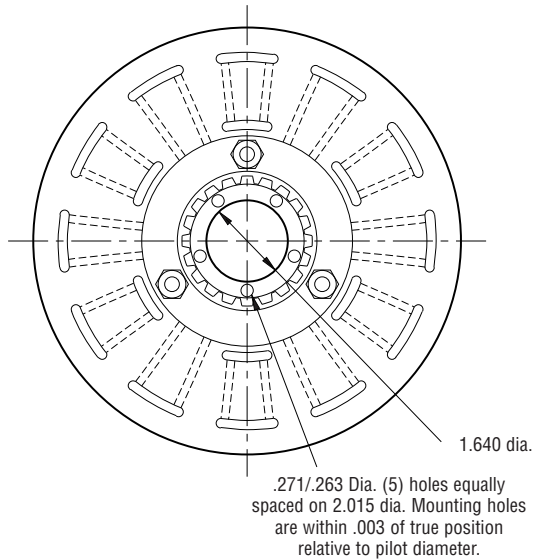

**ARMATURE VIEW**

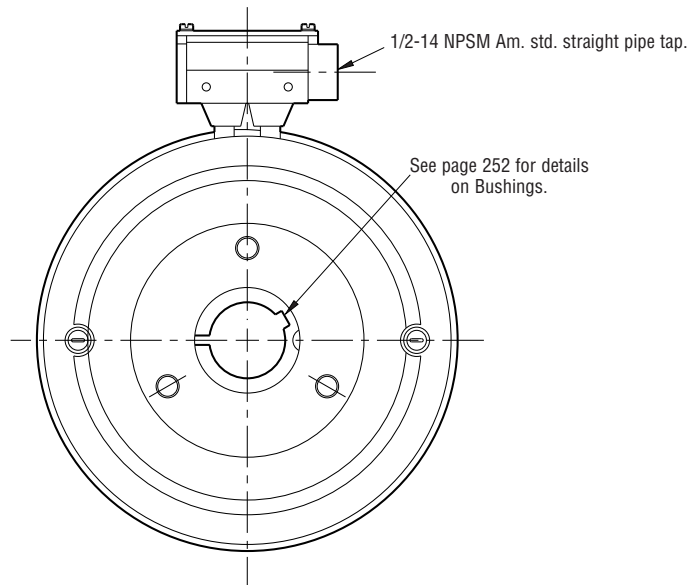

**COLLECTOR RING VIEW**

**Customer Shall Maintain:**

1. Splined hub pilot diameter to be concentric with splined armature center of rotation within .010 T.I.R.
2. Magnet hub shaft to be concentric with splined armature center of rotation within .006 T.I.R.

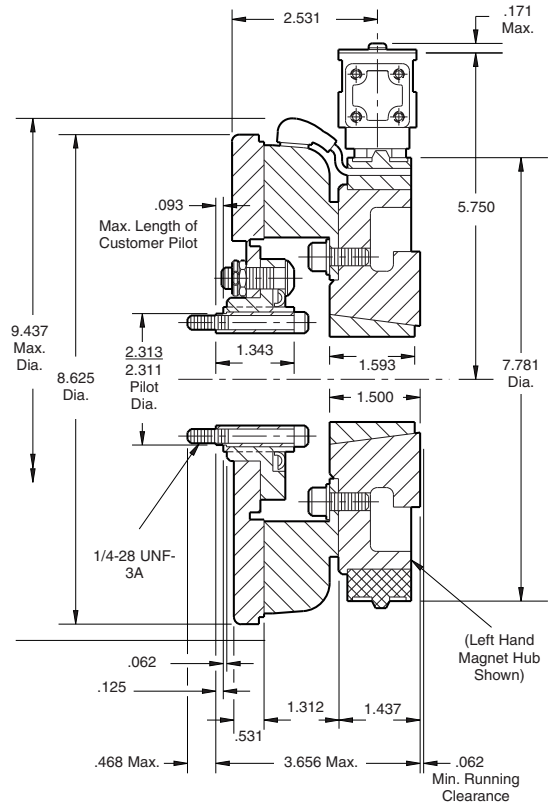

Shaft Size	.500 – 1.625
Static Torque	125 lb.ft.
Maximum Speed	4,000 rpm
Standard Voltage	D.C. 6, 24, 90

All dimensions are nominal unless otherwise noted.

Information on inertia and weights begins on page 239. Coil data is on pages 250 and 251.



Drawing I-25563

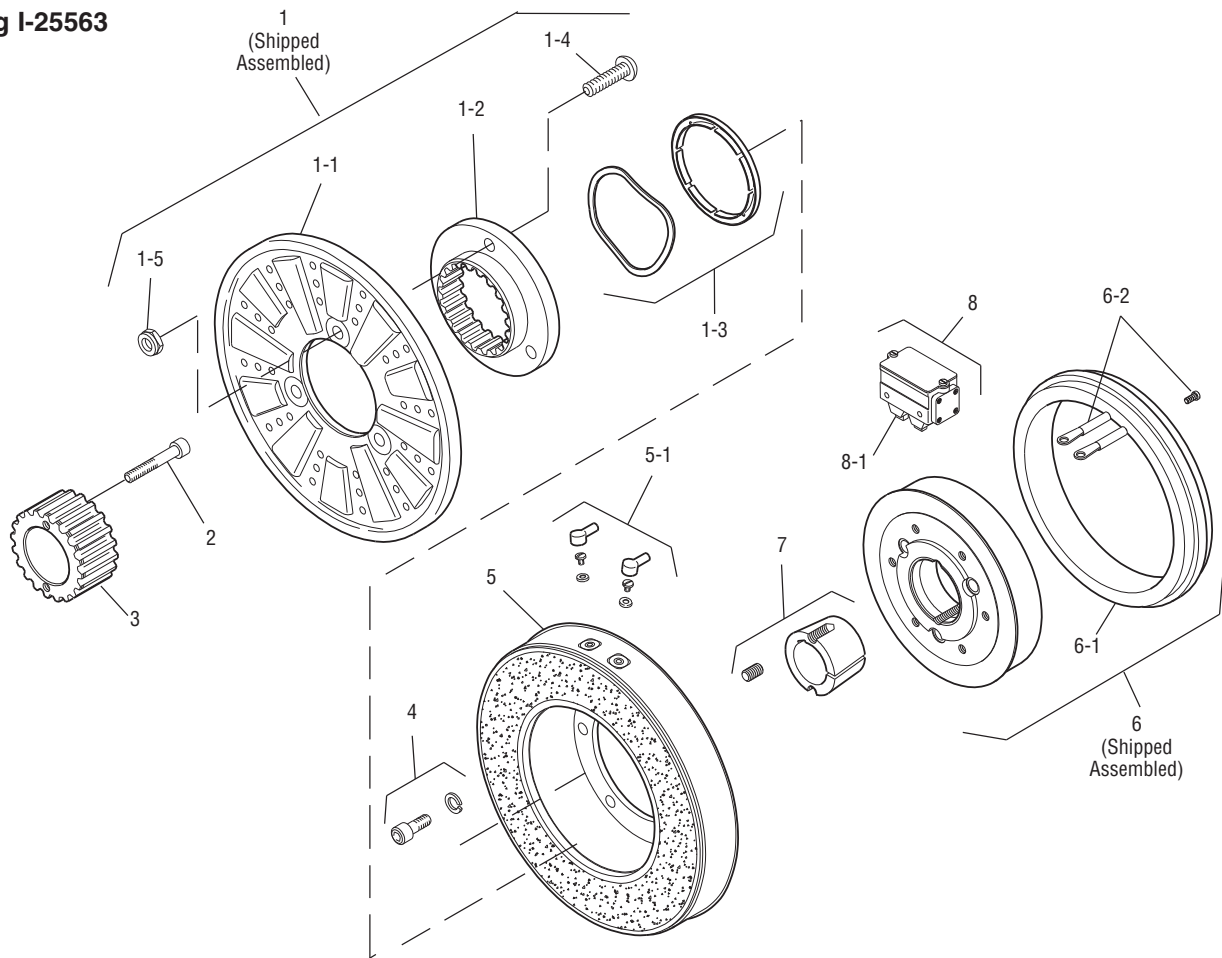

Item	Description	Part Number	Qty.
1	Armature & Splined		
	Adapter Assembly	5321-111-001	1
1-1	Armature	5321-111-022	1
1-2	Splined Armature Adapter	104-0008	1
1-3	Autogap Accessory	5321-101-006	1
	Autogap Spring	808-0054	1
	Retainer Ring	748-0373	1
1-4	Button Head Screw	797-0272	3
1-5	Locknut	661-0004	3
2	Mounting Accessory	5201-101-001	1
3	Splined Hub	540-0146	1
4	Mounting Accessory	5321-101-001	1
5	Magnet		1
	6 Volt	5301-631-002	
	24 Volt	5301-631-004	
	90 Volt	5301-631-005	
	†90 Volt LK Facing	5301-631-011	
5-1	Terminal Accessory	5311-101-001	1
6	Magnet Hub Assembly		1
	Right Hand	5301-541-002	
	Left Hand (shown)	5301-541-001	

Item	Description	Part Number	Qty.
6-1	Collector Ring	5301-749-001	1
6-2	Collector Ring Accessory	5301-101-002	1
7	Bushing, Taperlock*	180-0131 to 180-0149	1
8	Brushholder	5300-178-001	1
8-1	Brush	176-0001	4

### How to Order:

1. Specify Voltage for Item 5.
2. Specify Bore Size for Item 7.
3. Specify left hand or right hand hub for Item 6.
4. See Controls Section.

### Example:

PC-825 Clutch per I-25563 - 90 Volt, L.H. hub, 1" Bore

These units meet the standards of UL508 and are listed under guide card #NMTR2, file #59164. These units are CSA certified under file #LR11543

\*See page 252 for specific part numbers.

Refer to Service Manual P-206.

†Optional LK facing available. For more information, see page 232.

# Clutch

## PC-1000 Normal Duty

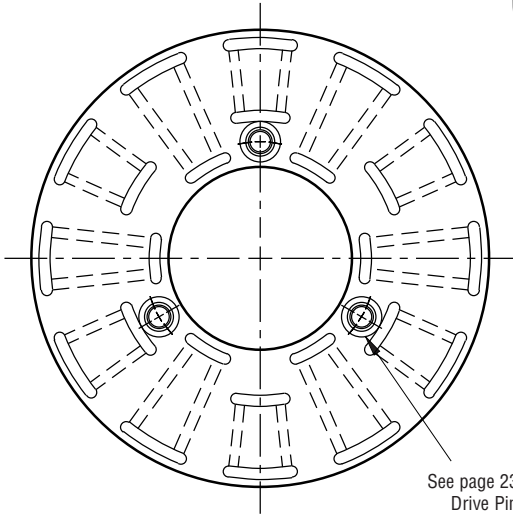

See page 230 for details on Drive Pin mountings.

### ARMATURE VIEW

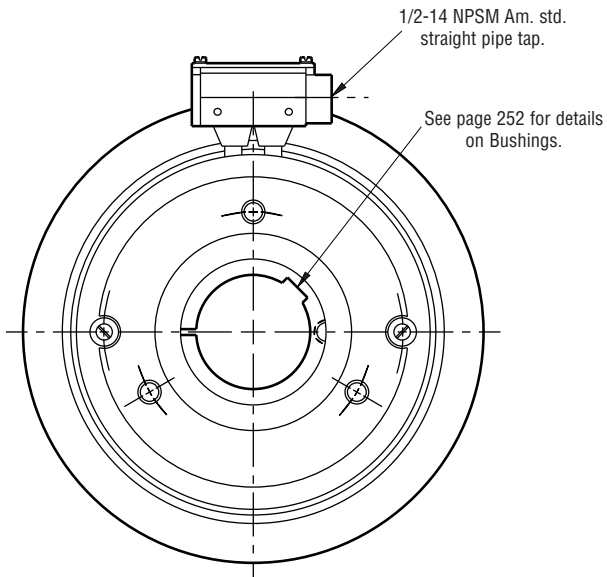

1/2-14 NPSM Am. std. straight pipe tap.

See page 252 for details on Bushings.

### COLLECTOR RING VIEW

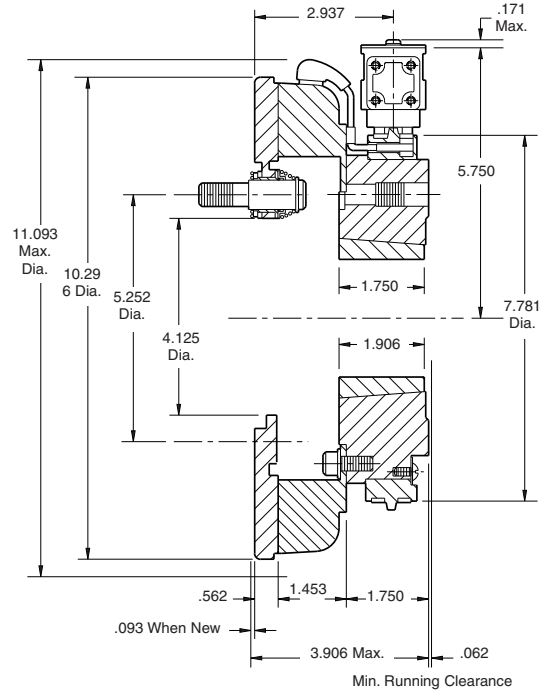

Shaft Size	.500 – 2.500
Static Torque	240 lb.ft.
Maximum Speed	3,600 rpm
Standard Voltage	D.C. 6, 24, 90

All dimensions are nominal unless otherwise noted.

Information on inertia and weights begins on page 239. Coil data is on pages 250 and 251.





Drawing I-25582

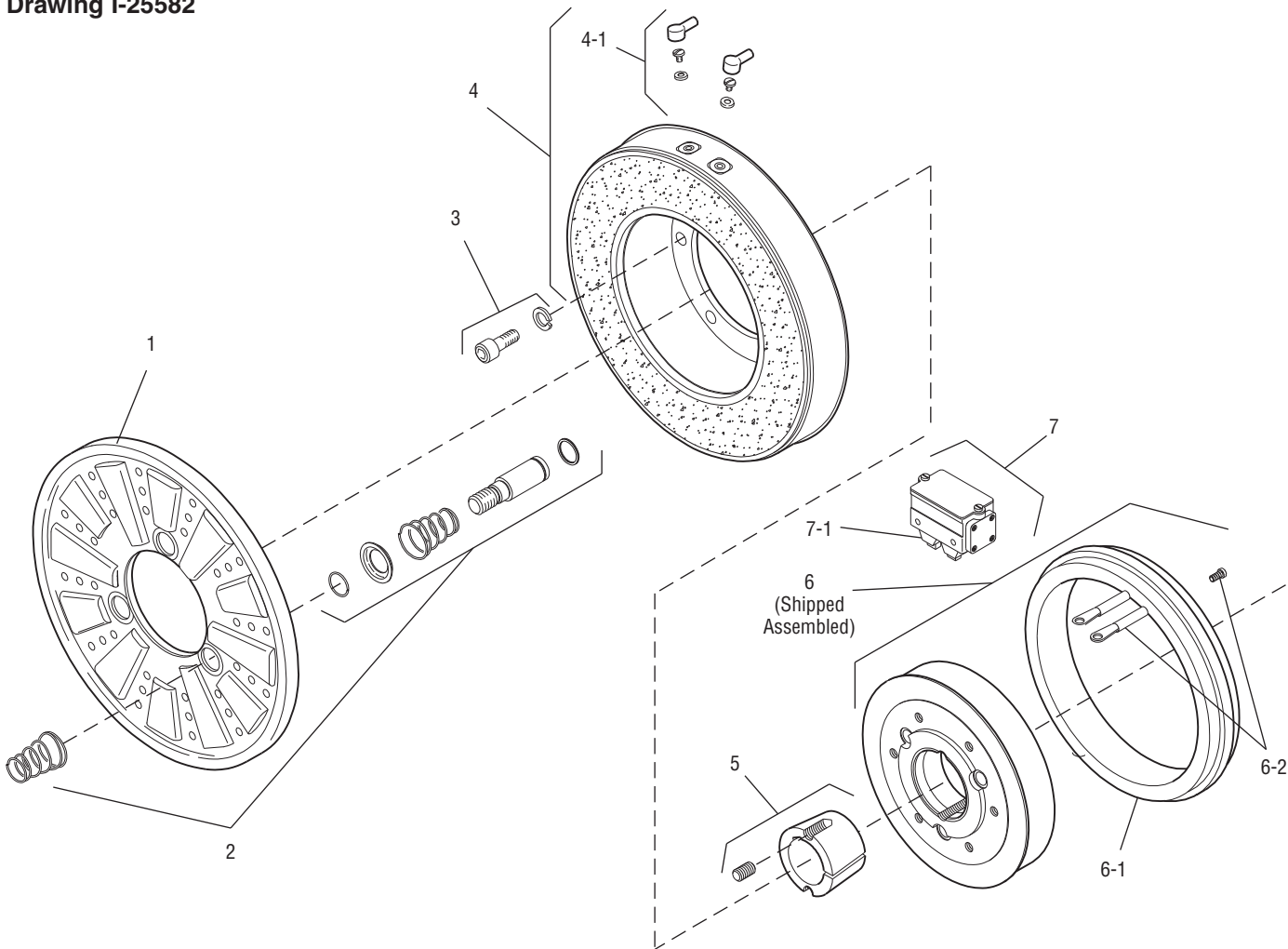

Item	Description	Part Number	Qty.
1	Armature	5302-111-013	1
2	Autogap Accessory	5201-101-008	3
3	Mounting Accessory	5321-101-001	1
4	Magnet		1
	6 Volt	5302-631-003	
	24 Volt	5302-631-014	
	90 Volt	5302-631-005	
	†90 Volt LK Facing	5302-631-001	
4-1	Terminal Accessory	5311-101-001	1
5	Bushing*		1
	1/2" to 2-1/2" Bore	180-0185 to 180-0217	
6	Magnet Hub		1
	Left Hand (shown)	5302-541-001	
	Right Hand	5302-541-002	
6-1	Collector Ring	5301-749-001	1
6-2	Collector Ring Accessory	5302-101-002	1
7	Brushholder	5300-178-001	1

Item	Description	Part Number	Qty.
7-1	Brush	176-0001	4

**How to Order:**

1. Specify Voltage for Item 4.
2. Specify Bore Size for Item 5.
3. Specify left hand or right hand hub for Item 6. (Bushing enters from magnet side for L.H. hub and from hub side for R.H.)
4. See Controls Section.

**Example:**

PC-1000 Clutch per I-25582 - 90 Volt, L.H. hub, 1" Bore

These units meet the standards of UL508 and are listed under guide card #NMTR2, file #59164.

These units are CSA certified under file #LR11543.

\*See page 252 for specific part numbers.

Refer to Service Manual P-206.

†Optional LK facing available. For more information, see page 232.

# Clutch

## PC-1000 Heavy Duty

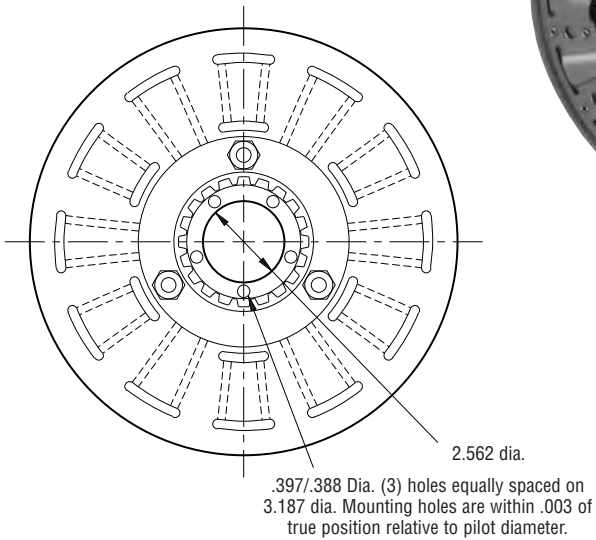

**ARMATURE VIEW**

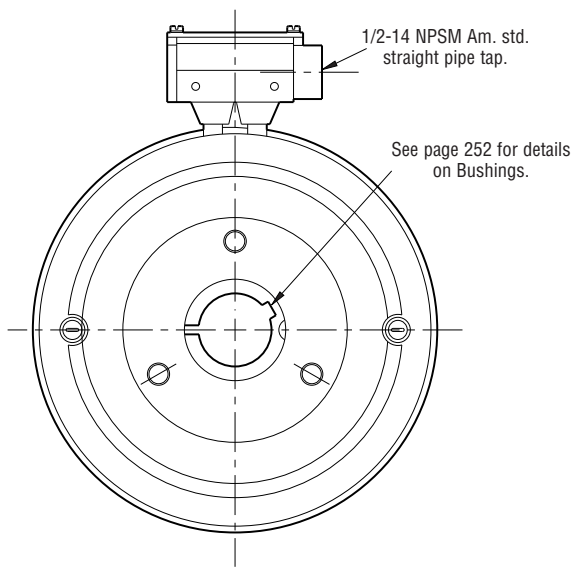

**COLLECTOR RING VIEW**

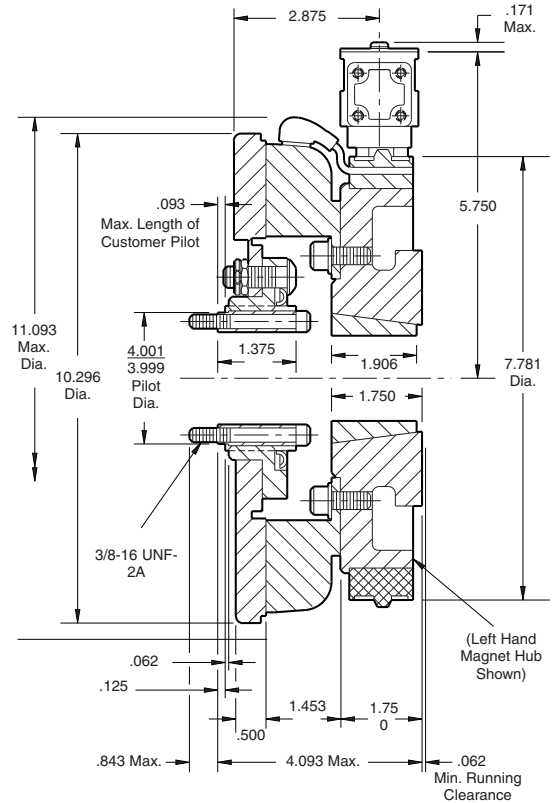

Shaft Size	.500 – 2.500
Static Torque	240 lb.ft.
Maximum Speed	3,600 rpm
Standard Voltage	D.C. 6, 24, 90

All dimensions are nominal unless otherwise noted.

Information on inertia and weights begins on page 239. Coil data is on pages 250 and 251.

### Customer Shall Maintain:

1. Splined hub pilot diameter to be concentric with splined armature center of rotation within .010 T.I.R.
2. Magnet hub shaft to be concentric with splined armature center of rotation within .006 T.I.R.



Drawing I-25583

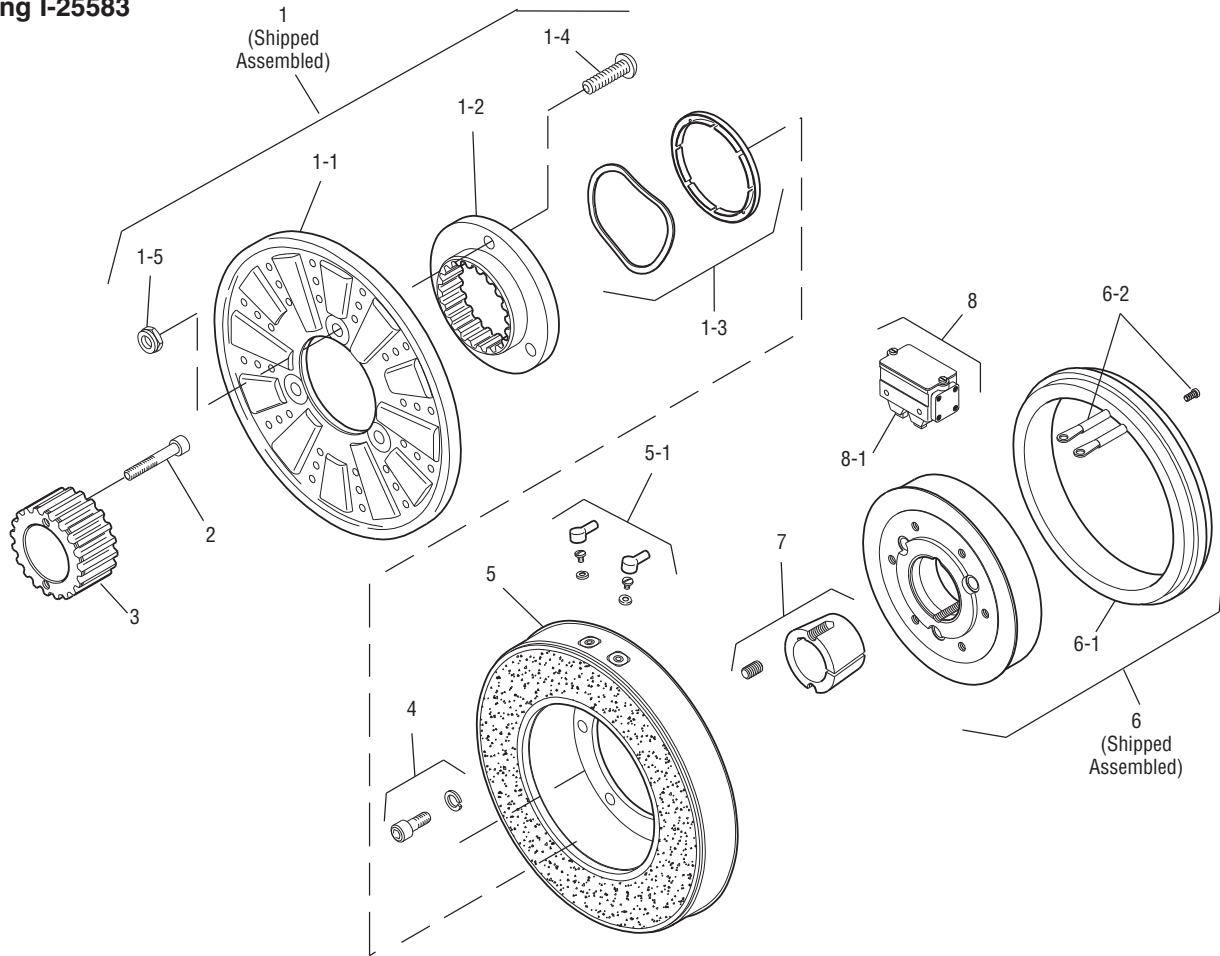

Item	Description	Part Number	Qty.
1	Armature & Splined Adapter Assembly	5322-111-002	1
1-1	Armature	5322-111-036	1
1-2	Splined Armature Adapter	104-0009	1
1-3	Autogap Accessory	5322-101-004	1
	Autogap Spring	808-0061	1
	Retainer Ring	748-0374	1
1-4	Button Head Screw	797-0272	3
1-5	Locknut	661-0004	3
2	Mounting Accessory	5202-101-001	1
3	Splined Hub	540-0147	1
4	Mounting Accessory	5321-101-001	1
5	Magnet		1
	6 Volt	5302-631-003	
	24 Volt	5302-631-014	
	90 Volt	5302-631-005	
	†90 Volt LK Facing	5302-631-001	
5-1	Terminal Accessory	5311-101-001	1
6	Magnet Hub Assembly		1
	Right Hand	5302-541-002	
	Left Hand (shown)	5302-541-001	

Item	Description	Part Number	Qty.
6-1	Collector Ring	5301-749-001	1
6-2	Collector Ring Accessory	5302-101-002	1
7	Bushing, Taperlock*	180-0185 to 180-0217	1
8	Brushholder	5300-178-001	1
8-1	Brush	176-0001	4

### How to Order:

1. Specify Voltage for Item 5.
2. Specify Bore Size for Item 7.
3. Specify left hand or right hand hub for Item 6.
4. See Controls Section.

### Example:

PC-1000 Clutch per I-25583 - 90 Volt,  
L.H. hub, 1" Bore

These units meet the standards of UL508 and are listed under guide card #NMTR2, file #59164.

These units are CSA certified under file #LR11543

\*See page 252 for specific part numbers.

Refer to Service Manual P-206.

†Optional LK facing available. For more information, see page 232.

# Clutch

## PC-1225 Normal Duty

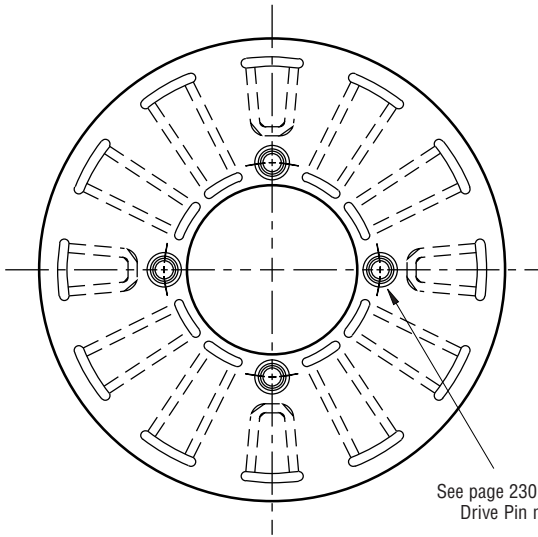

See page 230 for details on Drive Pin mountings.

**ARMATURE VIEW**

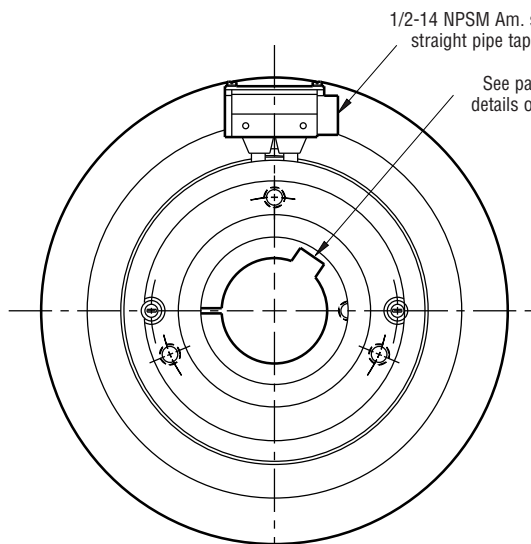

1/2-14 NPSM Am. std. straight pipe tap.

See page 252 for details on Bushings.

**COLLECTOR RING VIEW**

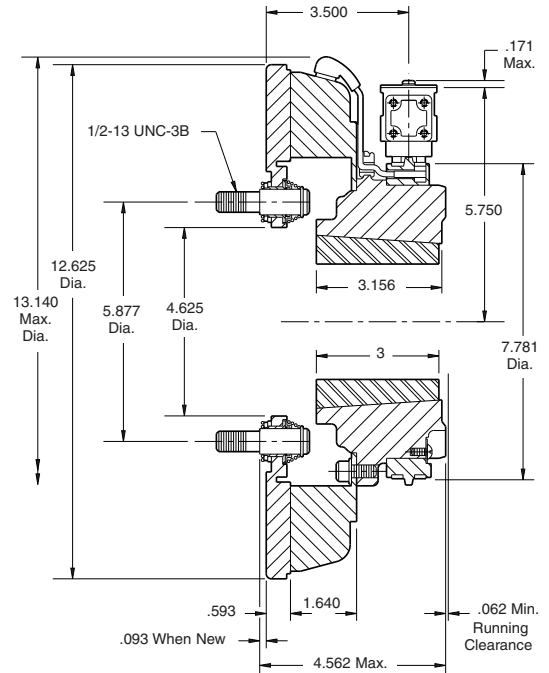

Shaft Size	.937 – 3.000
Static Torque	465 lb.ft.
Maximum Speed	3,000 rpm
Standard Voltage	D.C. 6, 24, 90

All dimensions are nominal unless otherwise noted.

Information on inertia and weights begins on page 239. Coil data is on pages 250 and 251.



Drawing I-25602

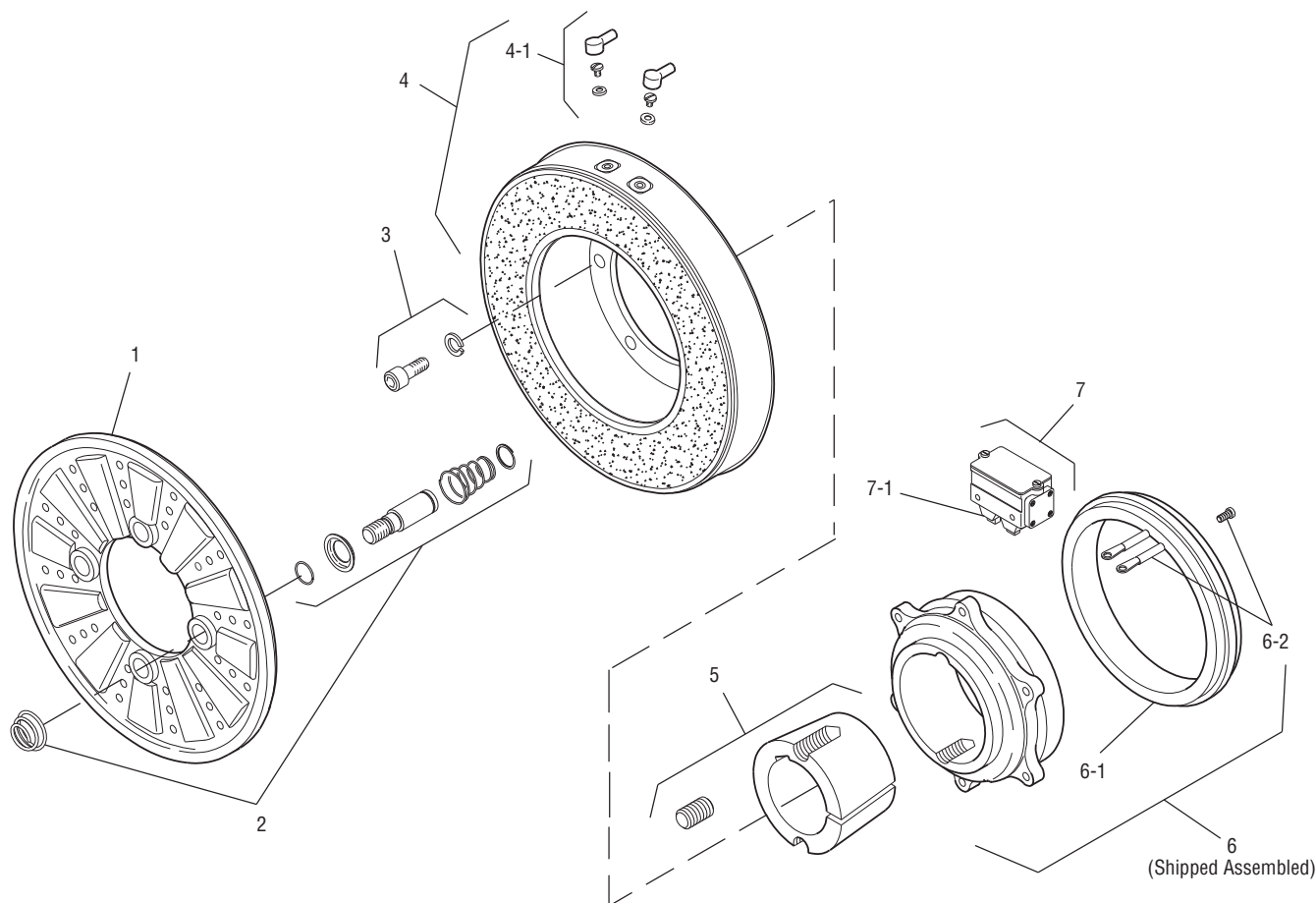

Item	Description	Part Number	Qty.
1	Armature	5303-111-009	1
2	Autogap Accessory	5201-101-008	4
3	Mounting Accessory	5321-101-001	1
4	Magnet		1
	6 Volt	5303-631-005	
	24 Volt	5303-631-007	
	90 Volt	5303-631-008	
	†90 Volt LK Facing	5303-631-001	
4-1	Terminal Accessory	5311-101-001	1
5	Bushing*		1
	15/16" to 3" Bore	180-0262 to 180-0295	
6	Magnet Hub		1
	Left Hand (shown)	5303-541-001	
	Right Hand	5303-541-002	
6-1	Collector Ring	5301-749-001	1
6-2	Collector Ring Accessory	5303-101-004	1

Item	Description	Part Number	Qty.
7	Brushholder	5300-178-001	1
7-1	Brush	176-0001	4

### How to Order:

1. Specify Voltage for Item 4.
2. Specify Bore Size for Item 5.
3. Specify left hand or right hand hub for Item 6. (Bushing enters from magnet side for L.H. hub and from hub side for R.H.)
4. See Controls Section.

### Example:

PC-1225 Clutch per I-25602 - 90 Volt, L.H. hub, 1" Bore  
 These units meet standards set forth in UL508 and are listed under guide card #NMTR2, file #59164.  
 These units are CSA certified under file #LR11543

\*See page 252 for specific part numbers.

Refer to Service Manual P-207.

†Optional LK facing available. For more information, see page 232.

# Clutch

## PC-1225 Heavy Duty

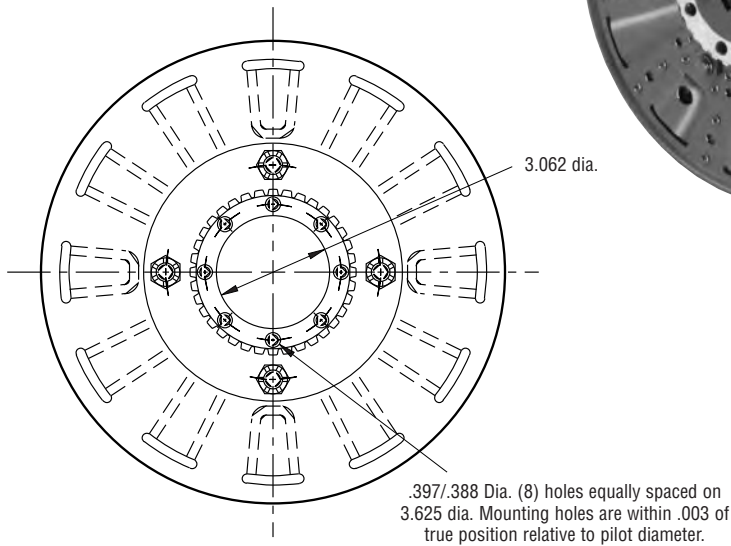
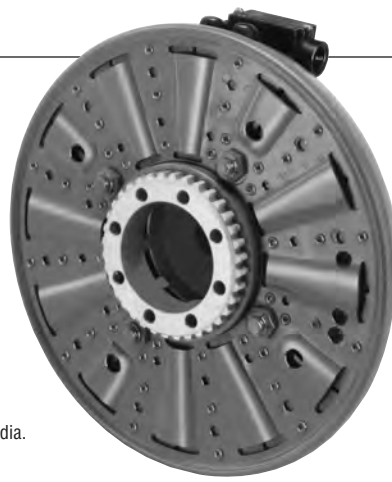

**ARMATURE VIEW**

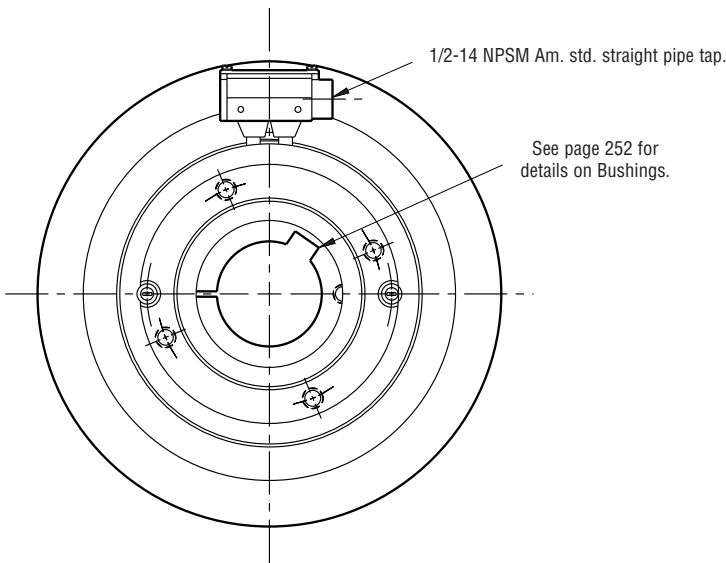

**COLLECTOR RING VIEW**

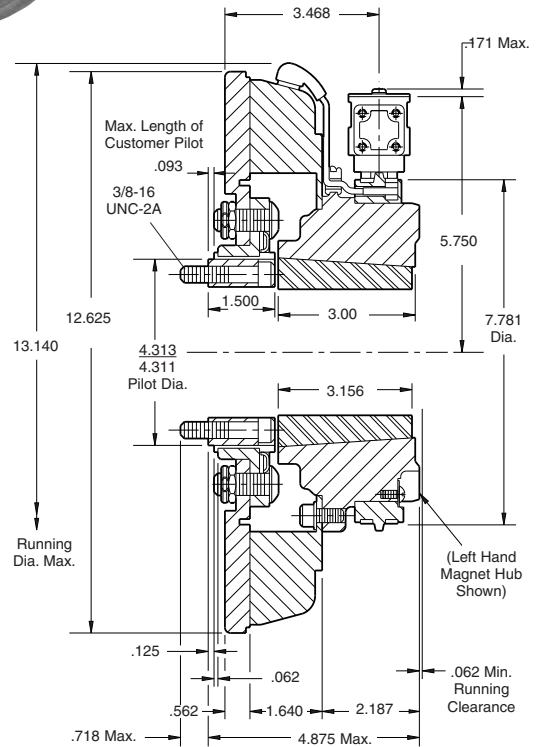

Shaft Size	.937 – 3.000
Static Torque	465 lb.ft.
Maximum Speed	3,000 rpm
Standard Voltage	D.C. 6, 24, 90

All dimensions are nominal unless otherwise noted.

Information on inertia and weights begins on page 239. Coil data is on pages 250 and 251.

### Customer Shall Maintain:

1. Splined hub pilot diameter to be concentric with splined armature center of rotation within .010 T.I.R.



**Drawing I-25603**

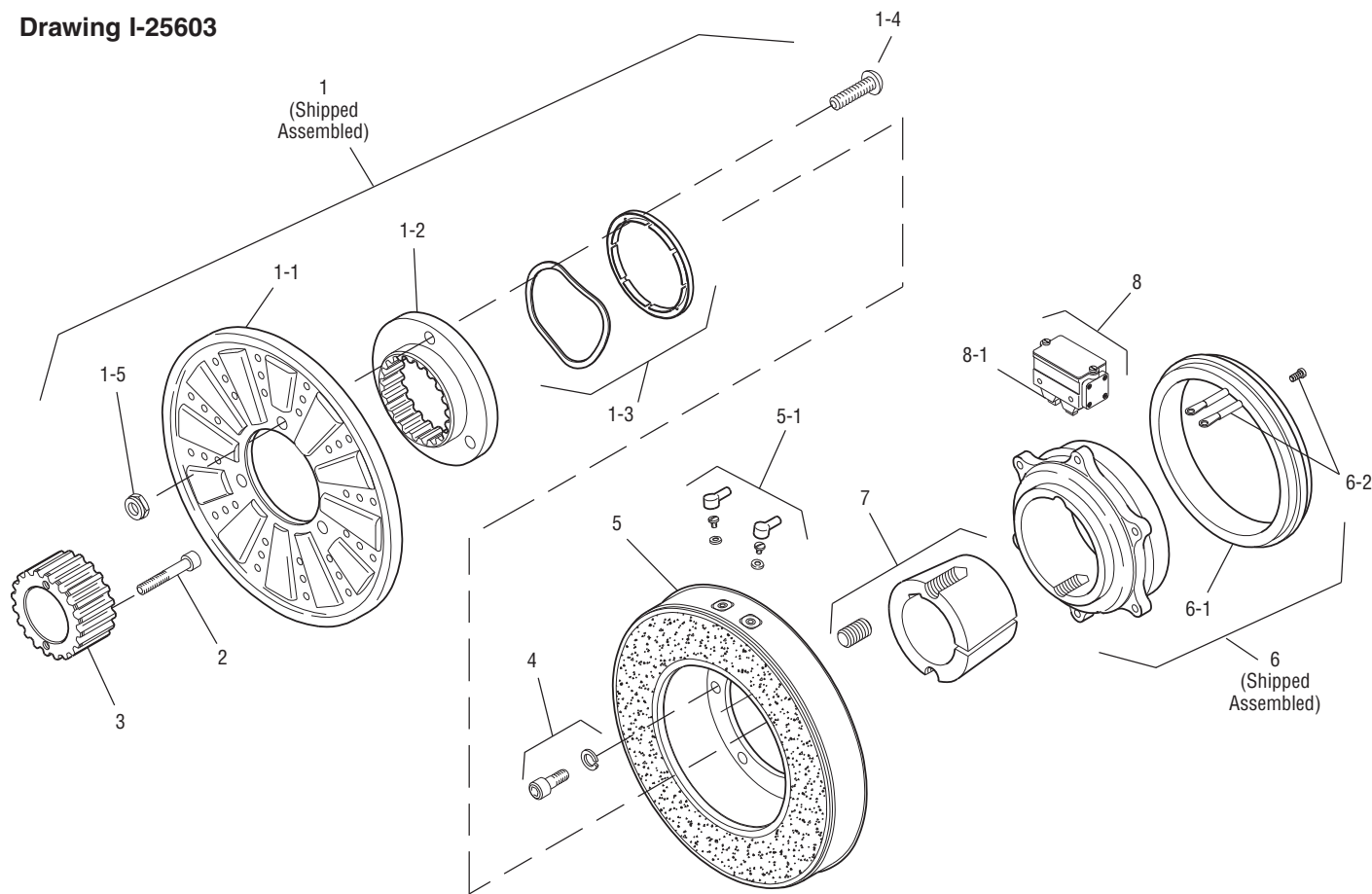

Item	Description	Part Number	Qty.
1	Armature & Splined Adapter Assembly	5323-111-001	1
1-1	Armature	5323-111-034	1
1-2	Splined Armature Adapter	104-0010	1
1-3	Autogap Accessory	5323-101-002	1
	Autogap Spring	808-0044	1
	Retainer Ring	748-0370	1
1-4	Button Head Screw	797-0281	4
1-5	Locknut	661-0005	4
2	Mounting Accessory	5202-101-001	1
3	Splined Hub	540-0148	1
4	Mounting Accessory	5321-101-001	1
5	Magnet		1
	6 Volt	5303-631-005	
	24 Volt	5303-631-007	
	90 Volt	5303-631-008	
	†90 Volt LK Facing	5303-631-001	
5-1	Terminal Accessory	5311-101-001	
6	Magnet Hub Assembly		1
	Right Hand	5303-541-002	
	Left Hand (shown)	5303-541-001	

Item	Description	Part Number	Qty.
6-1	Collector Ring	5301-749-001	1
6-2	Collector Ring Accessory	5303-101-004	1
7	Bushing, Taperlock*	180-0262 to 180-0295	1
8	Brushholder	5300-178-001	1
8-1	Brush	176-0001	4

**How to Order:**

1. Specify Voltage for Item 5.
2. Specify Bore Size for Item 7.
3. Specify left hand or right hand hub for Item 6.
4. See Controls Section.

**Example:**

PC-1225 Clutch per I-25603 - 90 Volt, L.H. hub, 1" Bore

These units meet the standards of UL508 and are listed under guide card #NMTR2, file #59164.

These units are CSA certified under file #LR11543.

\*See page 252 for specific part numbers.

Refer to Service Manual P-206.

†Optional LK facing available. For more information, see page 232.

# Clutch

## PC-1525 Normal Duty

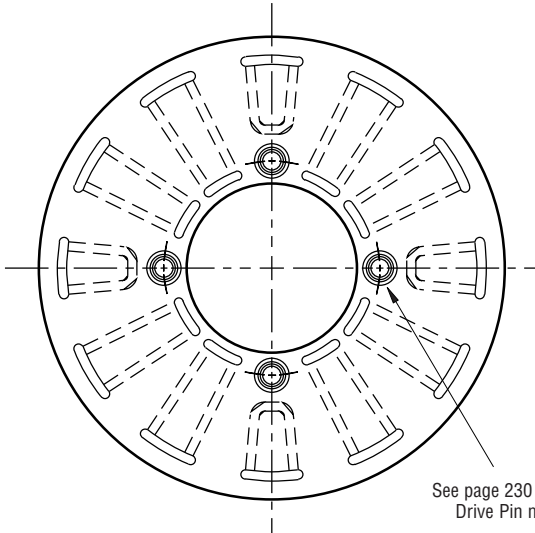

See page 230 for details on Drive Pin mountings.

**ARMATURE VIEW**

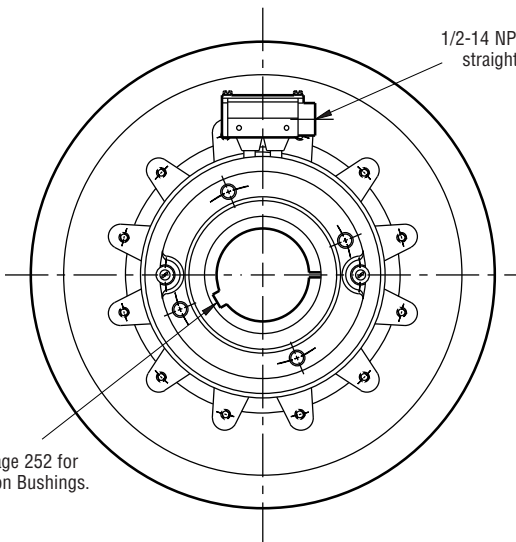

1/2-14 NPSM Am. std. straight pipe tap.

See page 252 for details on Bushings.

**COLLECTOR RING VIEW**

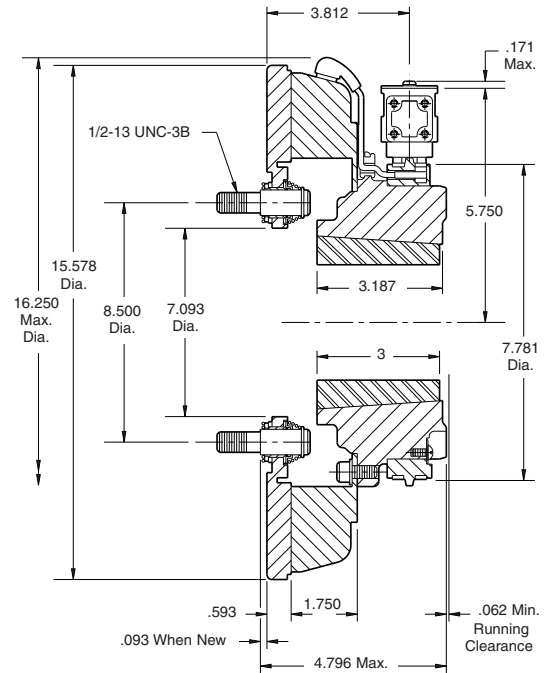

Shaft Size	.937 – 3.000
Static Torque	700 lb.ft.
Maximum Speed	2,000 rpm
Standard Voltage	D.C. 6, 24, 90

All dimensions are nominal unless otherwise noted.

Information on inertia and weights begins on page 239. Coil data is on pages 250 and 251.





Drawing I-25628

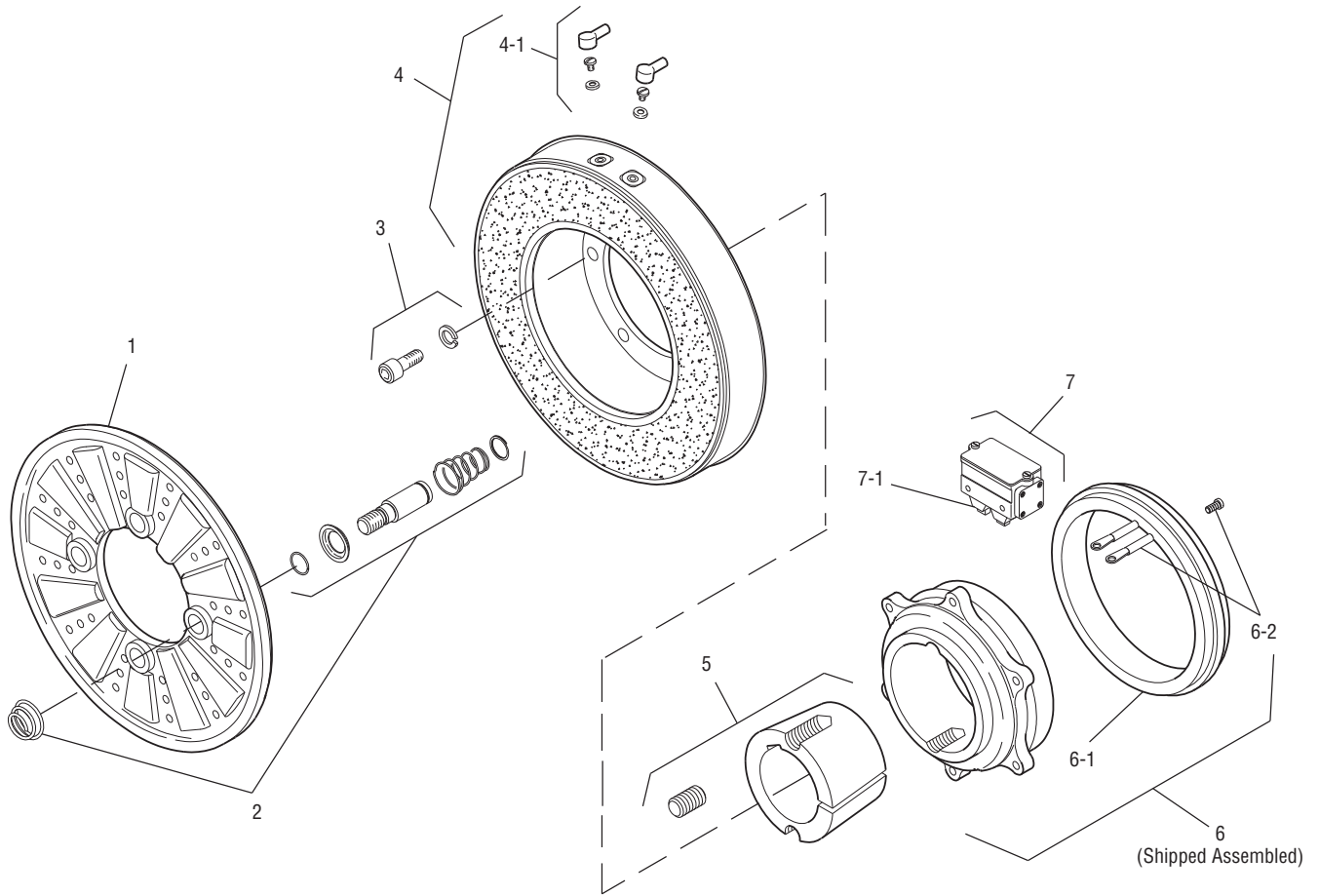

Item	Description	Part Number	Qty.
1	Armature	5304-111-004	1
2	Autogap Accessory	5201-101-008	4
3	Mounting Accessory	5321-101-001	2
4	Magnet		1
	6 Volt	5304-631-009	
	24 Volt	5304-631-011	
	90 Volt	5304-631-010	
	†90 Volt LK Facing	5304-631-002	
4-1	Terminal Accessory	5311-101-001	1
5	Bushing*		1
	15/16" to 3" Bore	180-0262 to 180-0295	
6	Magnet Hub		1
	Left Hand (shown)	5304-541-001	
	Right Hand	5304-541-002	
6-1	Collector Ring	5301-749-001	1
6-2	Collector Ring Accessory	5304-101-004	1

Item	Description	Part Number	Qty.
7	Brushholder	5300-178-001	1
7-1	Brush	176-0001	4

### How to Order:

1. Specify Voltage for Item 4.
2. Specify Bore Size for Item 5.
3. Specify left hand or right hand hub for Item 6. (Bushing enters from magnet side for L.H. hub and from hub side for R.H.)
4. See Controls Section.

### Example:

PC-1525 Clutch per I-25628 - 90 Volt, L.H. hub, 1" Bore

These units meet standards set forth in UL508 and are listed under guide card #NMTR2, file #59164.

These units are CSA certified under file #LR11543

\*See page 252 for specific part numbers.

Refer to Service Manual P-206.

†Optional LK facing available. For more information, see page 232.

# Clutch

## PC-1525 Heavy Duty

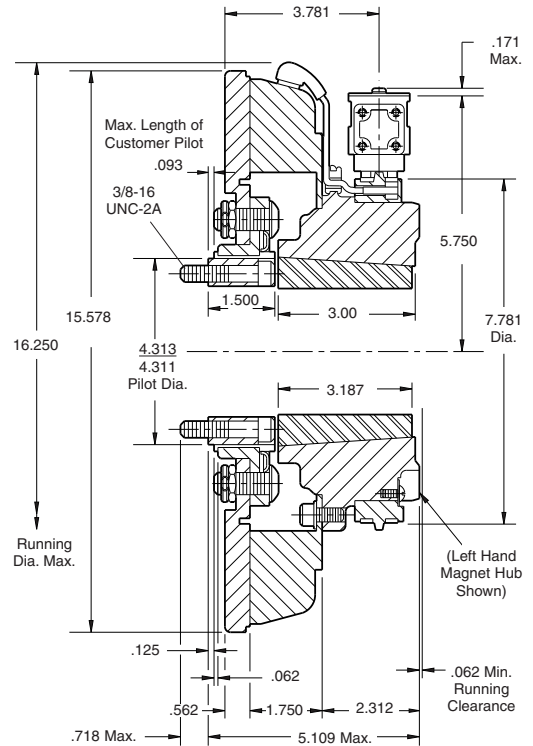
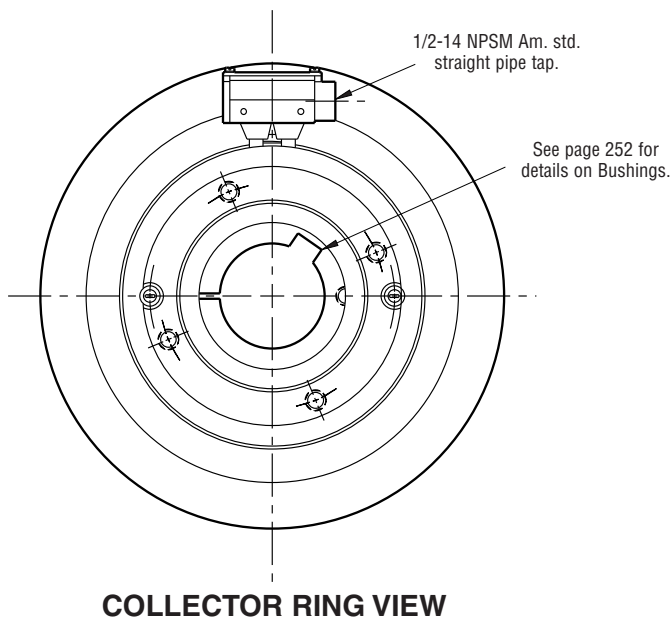
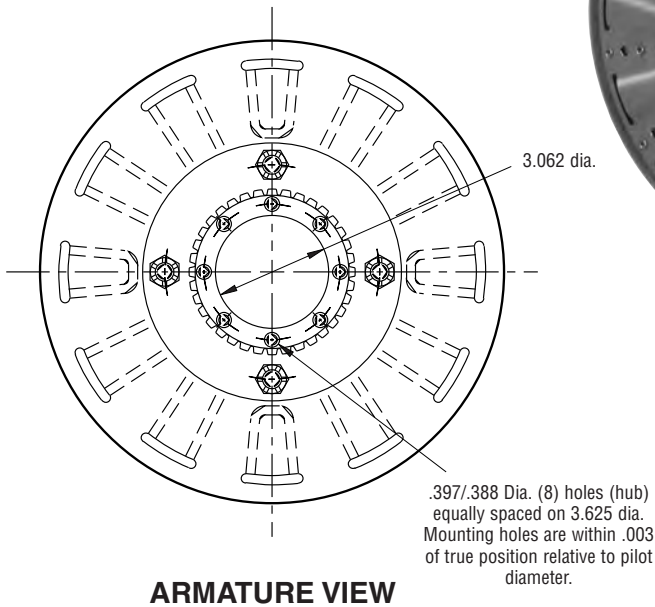

Shaft Size	.937 – 3.000
Static Torque	700 lb.ft.
Maximum Speed	2,000 rpm
Standard Voltage	D.C. 6, 24, 90

All dimensions are nominal unless otherwise noted.

Information on inertia and weights begins on page 239. Coil data is on pages 250 and 251.

### Customer Shall Maintain:

1. Splined hub pilot diameter to be concentric with splined armature center of rotation within .010 T.I.R.



Drawing I-25629

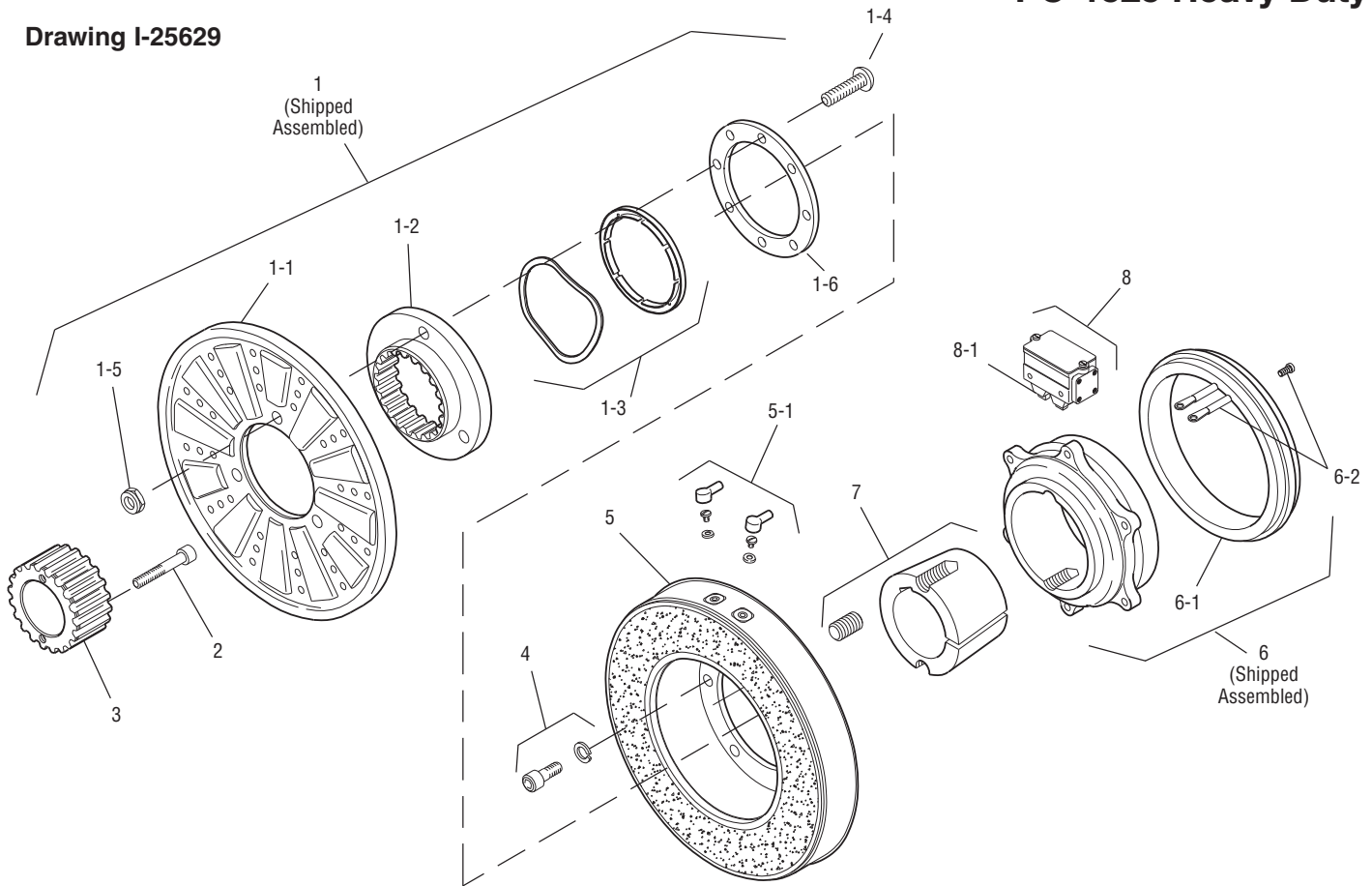

Item	Description	Part Number	Qty.
1	Armature & Splined Adapter Assembly	5324-111-001	1
1-1	Armature	5324-111-034	1
1-2	Splined Armature Adapter	104-0011	1
1-3	Autogap Accessory	5323-101-002	1
	Autogap Spring	808-0044	1
	Retainer Ring	748-0370	1
1-4	Button Head Screw	797-0272	8
1-5	Locknut	661-0004	8
1-6	Retainer Plate	686-0003	1
2	Mounting Accessory	5202-101-001	1
3	Splined Hub	540-0148	1
4	Mounting Accessory	5321-101-001	2
5	Magnet		1
	6 Volt	5304-631-009	
	24 Volt	5304-631-011	
	90 Volt	5304-631-010	
	†90 Volt LK Facing	5304-631-002	
5-1	Terminal Accessory	5311-101-001	1
6	Magnet Hub Assembly		1
	Right Hand	5304-541-002	
	Left Hand (shown)	5304-541-001	

Item	Description	Part Number	Qty.
6-1	Collector Ring	5301-749-001	1
6-2	Collector Ring Accessory	5304-101-004	1
7	Bushing, Taperlock*	180-0262 to 180-0295	1
8	Brushholder	5300-178-001	1
8-1	Brush	176-0001	4

**How to Order:**

1. Specify Voltage for Item 5.
2. Specify Bore Size for Item 7.
3. Specify left hand or right hand hub for Item 6.
4. See Controls Section.

**Example:**

PC-1525 Clutch per I-25629 - 90 Volt, L.H. hub, 1" Bore

These units meet the standards of UL508 and are listed under guide card #NMTR2, file #59164.

These units are CSA certified under file #LR11543.

\*See page 252 for specific part numbers.

Refer to Service Manual P-206.

†Optional LK facing available. For more information, see page 232.

# Clutch Coupling

## SFC-120 Flange Mounted

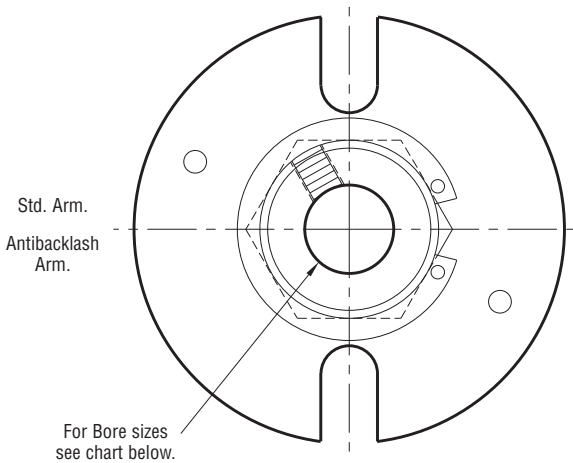
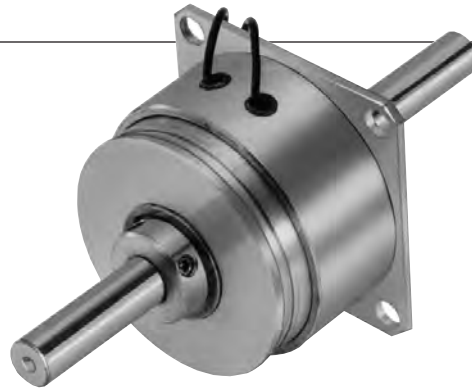

**ARMATURE VIEW**

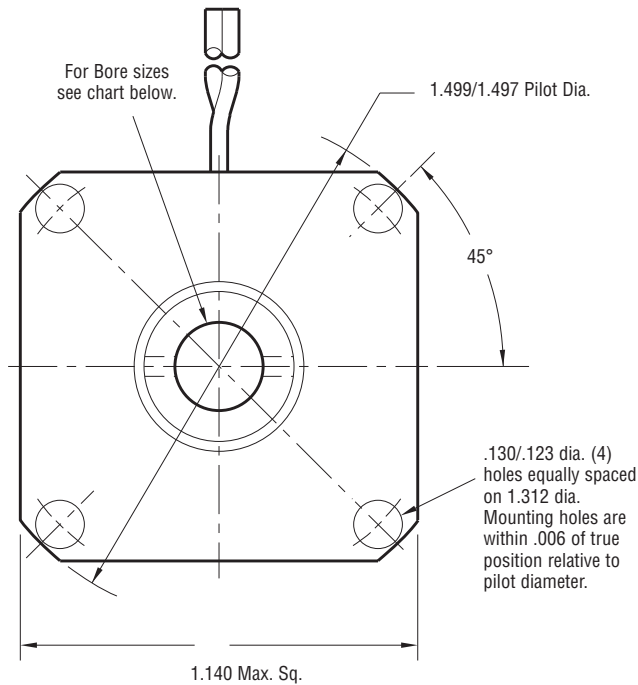

**FIELD VIEW**

### Customer Shall Maintain:

1. Squareness of field mounting face with rotor shaft within .003 T.I.R. measured at pilot diameter
2. Concentricity of field mounting pilot diameter with rotor mounting shaft within .003 T.I.R.
3. Rotor and armature shafts in line within .003 T.I.R.

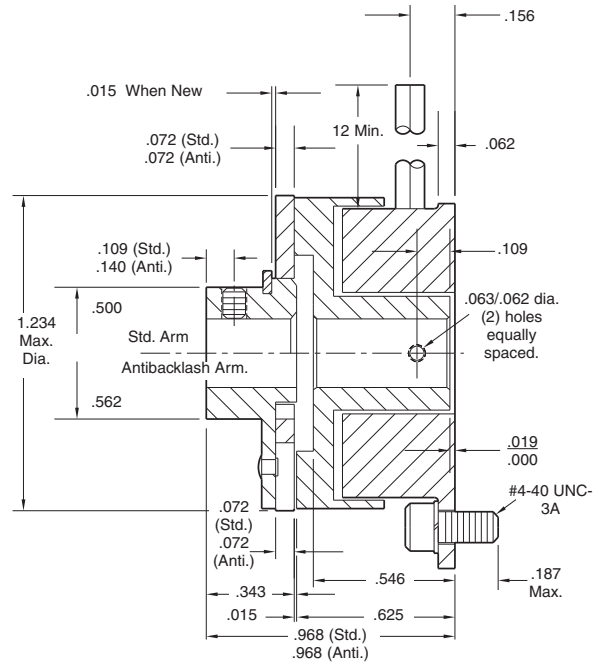

### Bore Dimensions

Rotor Bore Dia.	Armature Bore Dia.
.188/.187	.188/.187
.251/.250	.251/.250
.313/.312	(.313/.312)*

\*(Antibrake Armatures)

Static Torque	5 lb. in.
Maximum Speed	3,600 rpm
Standard Voltage	D.C. 6, 24, 90

All dimensions are nominal unless otherwise noted.

Information on inertia and weights begins on page 239. Coil data is on pages 250 and 251.



Drawing I-25503

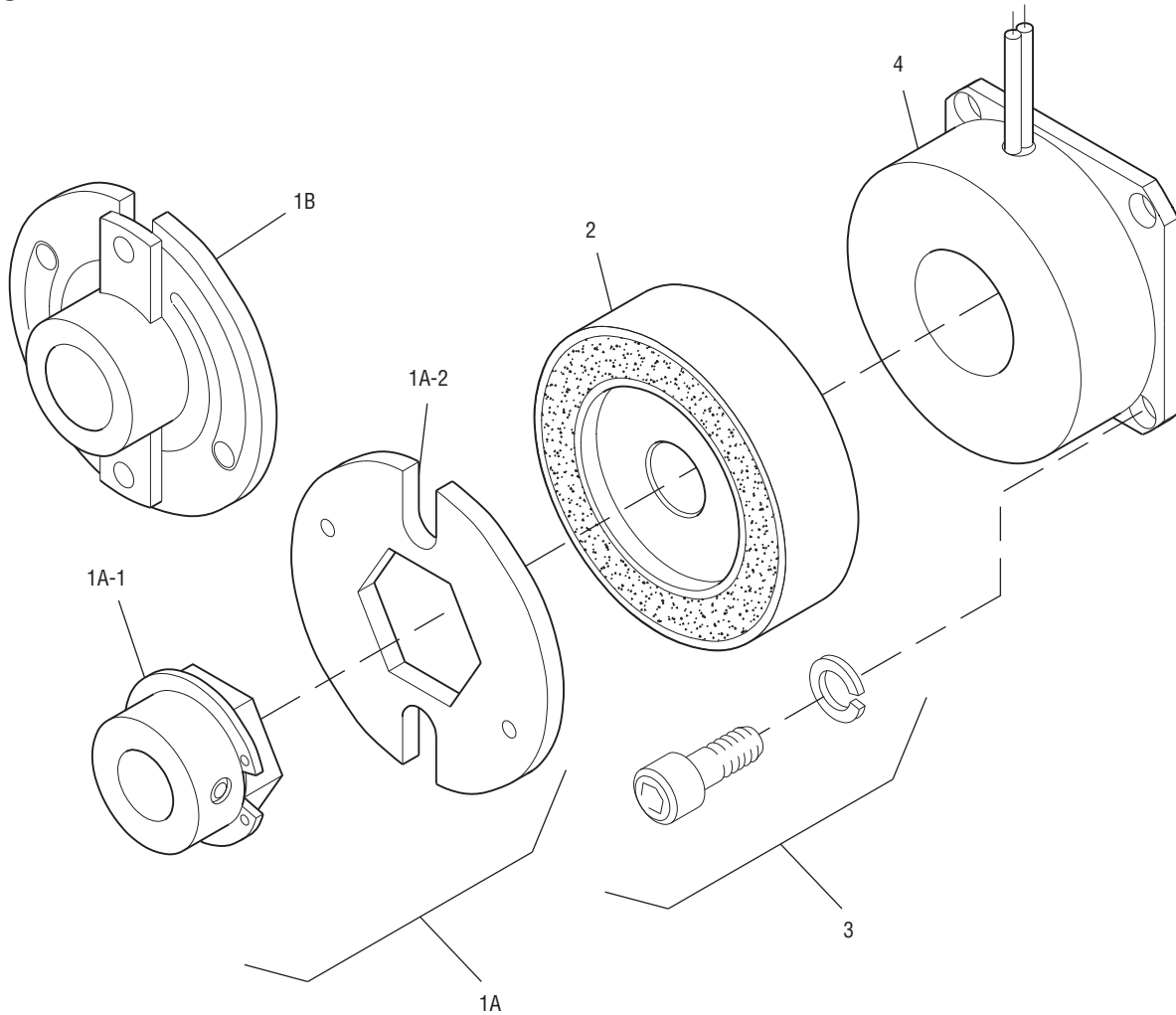

Item	Description	Part Number	Qty.
1A	Armature and Hub		
1A-1	Armature Hub		1
	3/16" Bore	5622-541-009	
	1/4" Bore	5622-541-008	
1A-2	Armature	110-0110	1
1B	Antibacklash Armature		1
	3/16" Bore	5622-111-004	
	1/4" Bore	5622-111-002	
	5/16" Bore	5622-111-003	
2	Rotor		1
	3/16" Bore	5602-751-004	
	1/4" Bore	5602-751-002	
	5/16" Bore	5602-751-003	
3	Mounting Accessory	5101-101-001	1
4	Field		1
	6 Volt	5602-451-003	
	24 Volt	5602-451-005	
	90 Volt	5602-451-007	

### How to Order:

1. Specify Type of Armature Desired.
2. Specify Bore Size for Item 1A-1 or 1B and Item 2.
3. Specify Voltage for Item 4.
4. See Controls Section.

### Example:

SFC-120 Clutch per I-25503 - 90 Volt  
 Standard Armature  
 1/4" Armature Hub Bore  
 1/4" Rotor Bore

These units meet standards set forth in UL508 and are listed under guide card #NMTR2, file #59164.

These units are CSA certified under file #LR11543.

Refer to Service Manual P-200.

# Clutch Coupling

## SFC-120 Bearing Mounted

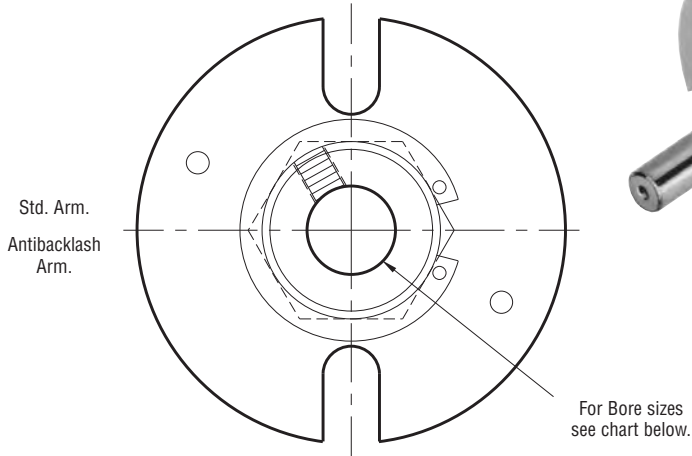

**ARMATURE VIEW**

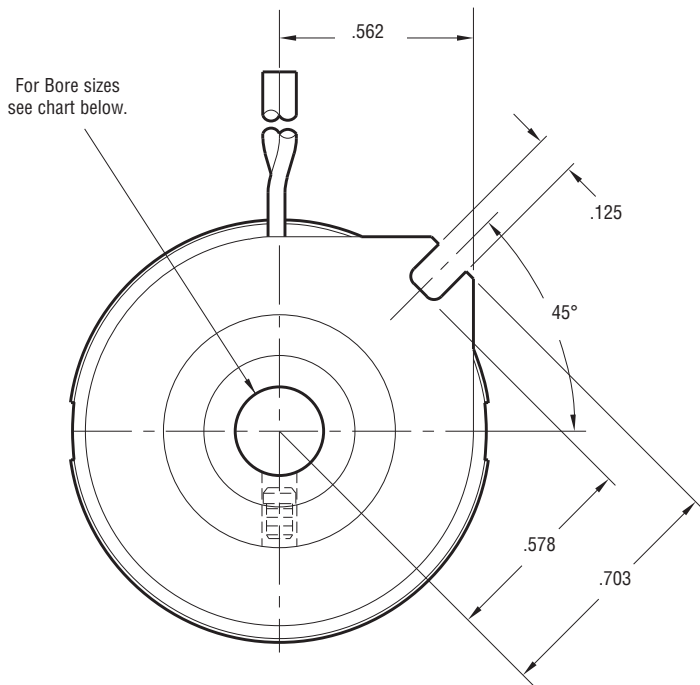

**FIELD VIEW**

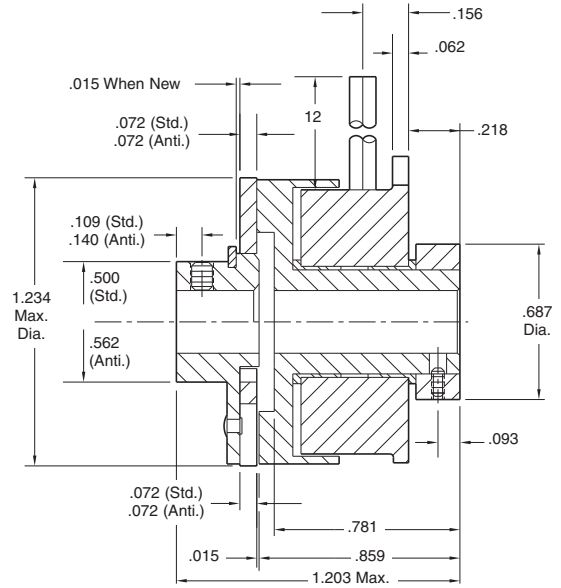

### Bore Dimensions

Rotor Bore Dia.	Armature Bore Dia.
.188/.187	.188/.187
.251/.250	.251/.250
.313/.312	(.313/.312)*

\*(Antibacklash Armatures)

Static Torque	5 lb. in.
Maximum Speed	3,600 rpm
Standard Voltage	D.C. 6, 24, 90

All dimensions are nominal unless otherwise noted.

Information on inertia and weights begins on page 239. Coil data is on pages 250 and 251.



Drawing I-25504

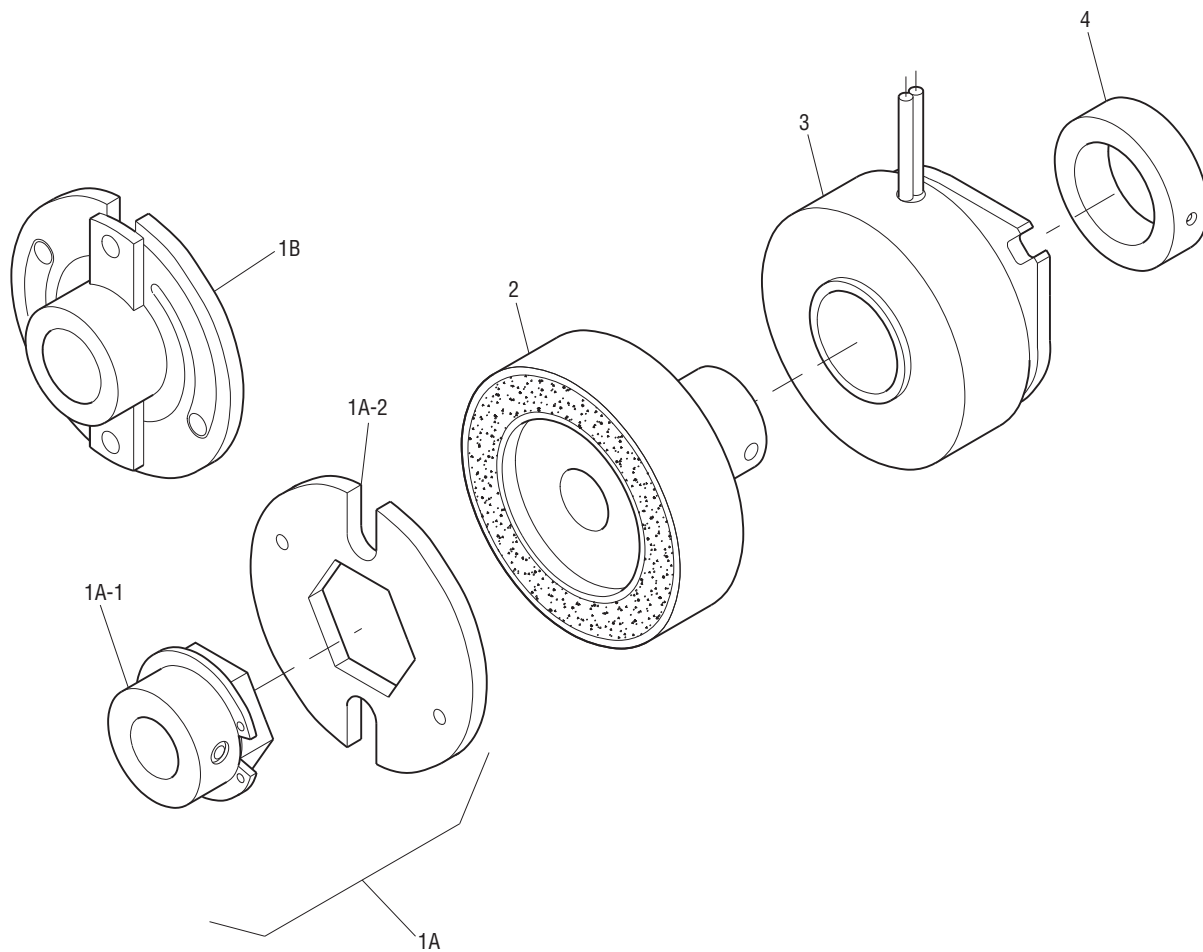

Item	Description	Part Number	Qty.
1A	Armature and Hub		
1A-1	Armature Hub		1
	3/16" Bore	5622-541-009	
	1/4" Bore	5622-541-008	
1A-2	Armature	110-0110	1
1B	Antibacklash Armature		1
	3/16" Bore	5622-111-004	
	1/4" Bore	5622-111-002	
	5/16" Bore	5622-111-003	
2	Rotor		1
	3/16" Bore	5602-751-008	
	1/4" Bore	5602-751-006	
	5/16" Bore	5602-751-007	
3	Field		1
	6 Volt	5602-451-021	
	24 Volt	5602-451-023	
	90 Volt	5602-451-025	
4	Set Collar	5602-266-001	1

### How to Order:

1. Specify Type of Armature Desired.
2. Specify Bore Size for Item 1A-1 or 1B and Item 2.
3. Specify Voltage for Item 3.
4. See Controls Section.

### Example:

SFC-120 Clutch per I-25504 - 90 Volt  
Standard Armature  
1/4" Armature Hub Bore

These units meet standards set forth in UL508 and are listed under guide card #NMTR2, file #59164.

These units are CSA certified under file #LR11543.

Refer to Service Manual P-200.

# Clutch Coupling

## SFC-170 Flange Mounted

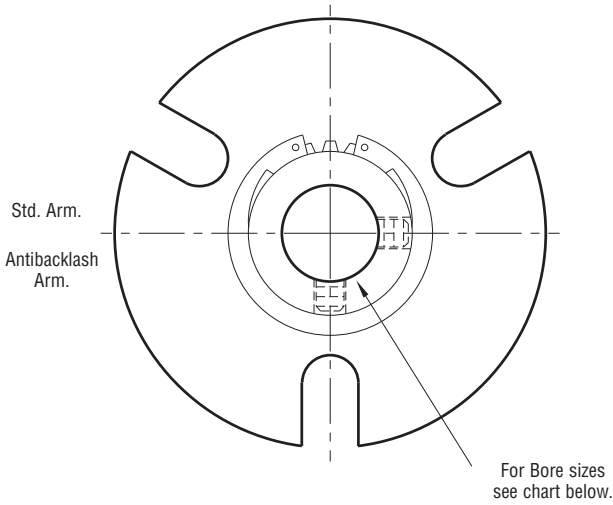
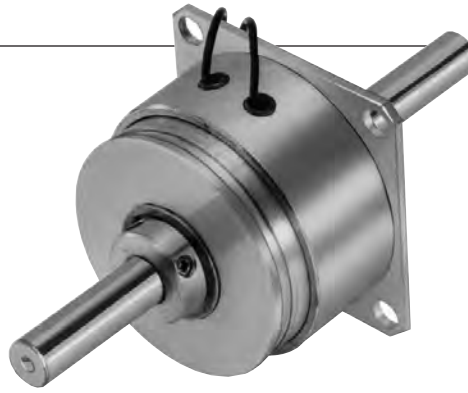

**ARMATURE VIEW**

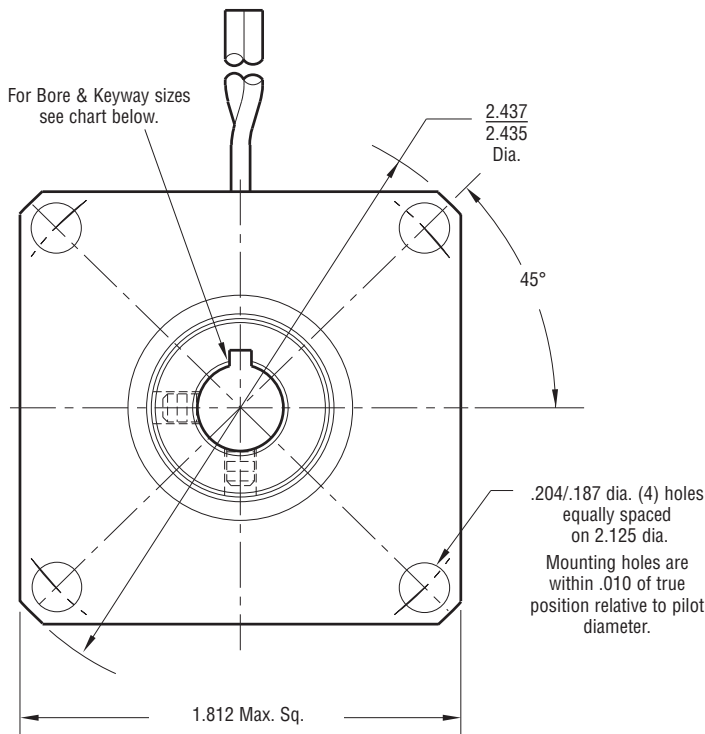

**FIELD VIEW**

### Customer Shall Maintain:

1. Squareness of field mounting face with rotor shaft within .003 T.I.R. measured at pilot diameter
2. Concentricity of field mounting pilot diameter with rotor mounting shaft within .003 T.I.R.
3. Rotor and armature shafts in line within .003 T.I.R.

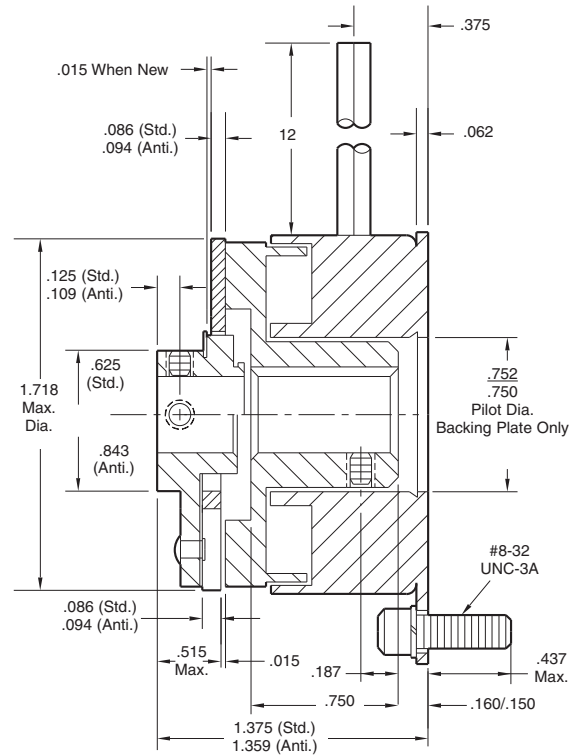

### Bore Dimensions

Rotor Bore Dia.	Keyway	Armature Bore Dia.
.251/.250	.062 x .031	.251/.250
.313/.312	.062 x .031	.313/.312
.376/.375	.093 x .046	.376/.375

Static Torque	15 lb. in.
Maximum Speed	5,000 rpm
Standard Voltage	D.C. 6, 24, 90

All dimensions are nominal unless otherwise noted.

Information on inertia and weights begins on page 239. Coil data is on pages 250 and 251.





Drawing I-25756

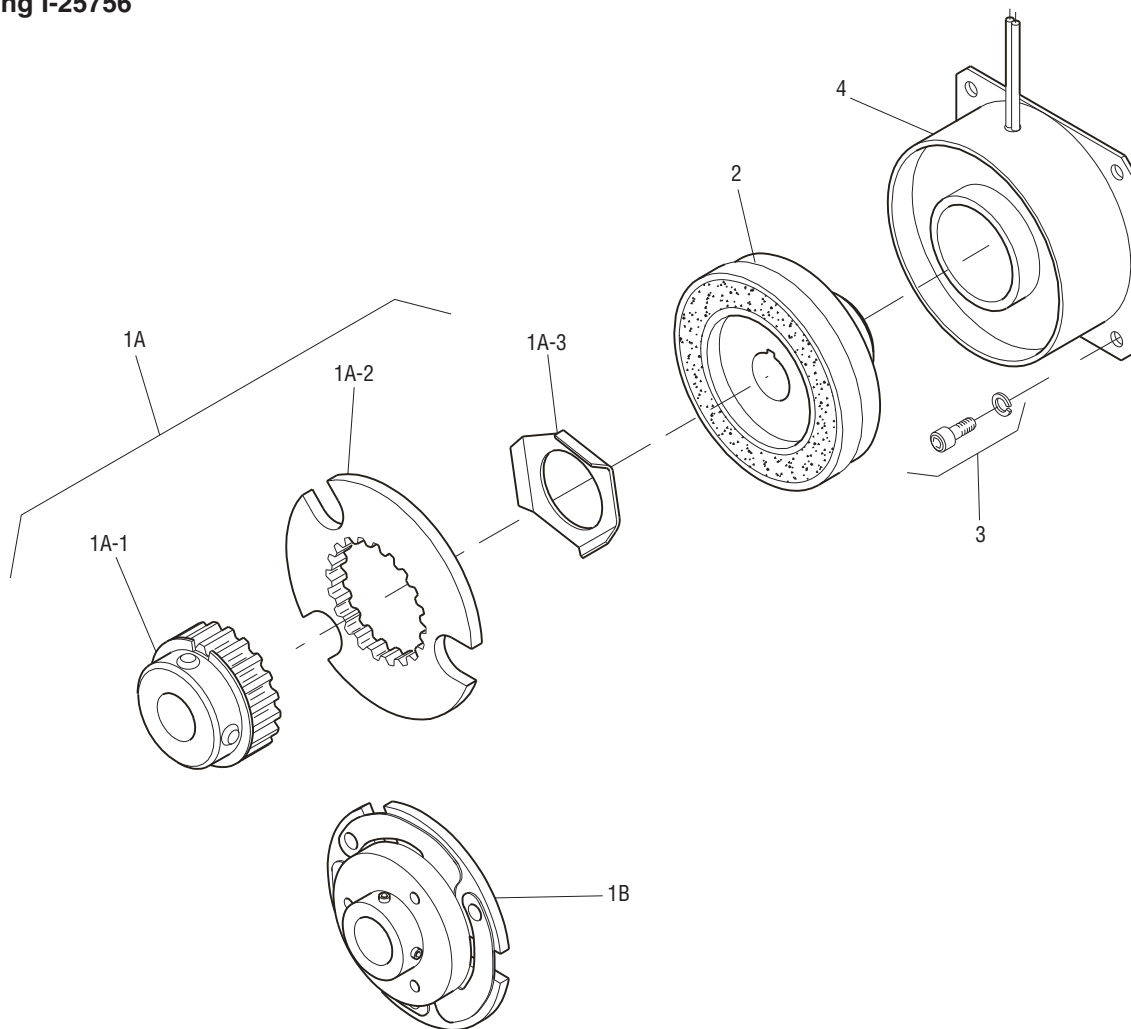

Item	Description	Part Number	Qty.
1A	Armature and Hub		
1A-1	Armature Hub		1
	1/4" Bore	5102-541-002	
	5/16" Bore	5102-541-003	
	3/8" Bore	5102-541-004	
1A-2	Armature	110-0111	1
1A-3	Release Spring	808-0019	1
1B	Antibacklash Armature		1
	1/4" Bore	5623-111-008	
	5/16" Bore	5623-111-009	
	3/8" Bore	5623-111-010	
2	Rotor		1
	1/4" Bore	5603-751-028	
	5/16" Bore	5603-751-029	
	3/8" Bore	5603-751-030	
3	Mounting Accessory	5102-101-001	1
4	Field		1
	6 Volt	5603-451-047	
	24 Volt	5603-451-049	
	90 Volt	5603-451-051	

**How to Order:**

1. Specify Type of Armature Desired.
2. Specify Bore Size for Item 1A-1 or 1B and Item 2.
3. Specify Voltage for Item 4.
4. See Controls Section.

**Example:**

SFC-170 Clutch per I-25756 - 90 Volt  
 Antibacklash Armature  
 1/4" Armature Hub Bore  
 1/4" Rotor Bore

These units meet standards set forth in UL508 and are listed under guide card #NMTR2, file #59164.

These units are CSA certified under file #LR11543.

Refer to Service Manual P-200.

# Clutch Coupling

## SFC-170 Bearing Mounted

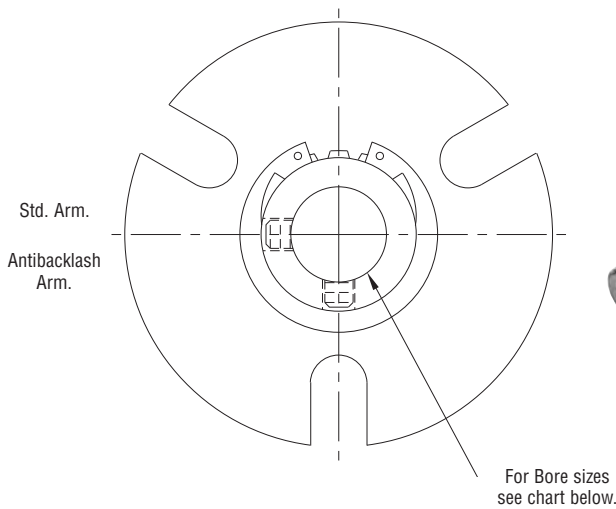
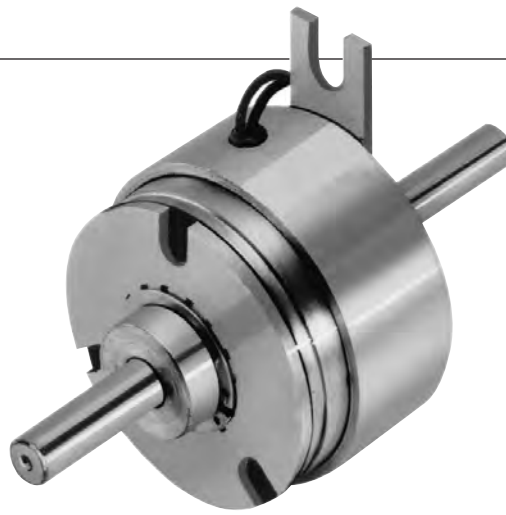

**ARMATURE VIEW**

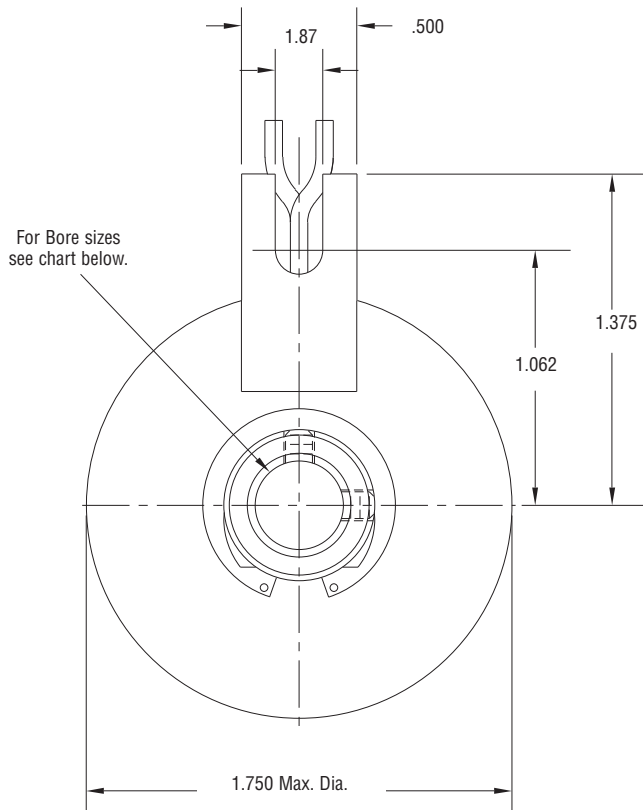

**FIELD VIEW**

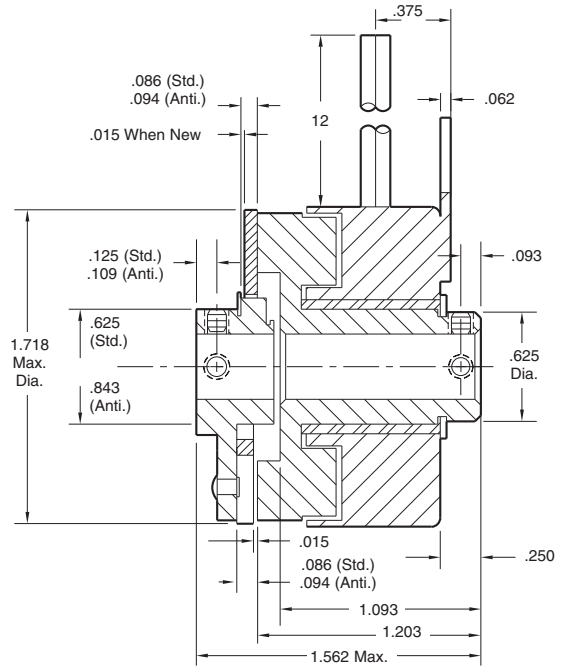

### Bore Dimensions

Rotor Bore Dia.	Armature Bore Dia.
.251/.250	.251/.250
.313/.312	.313/.312
.376/.375	.376/.375

Static Torque	15 lb. in.
Maximum Speed	5,000 rpm
Standard Voltage	D.C. 6, 24, 90

All dimensions are nominal unless otherwise noted.

Information on inertia and weights begins on page 239. Coil data is on pages 250 and 251.



Drawing I-25757

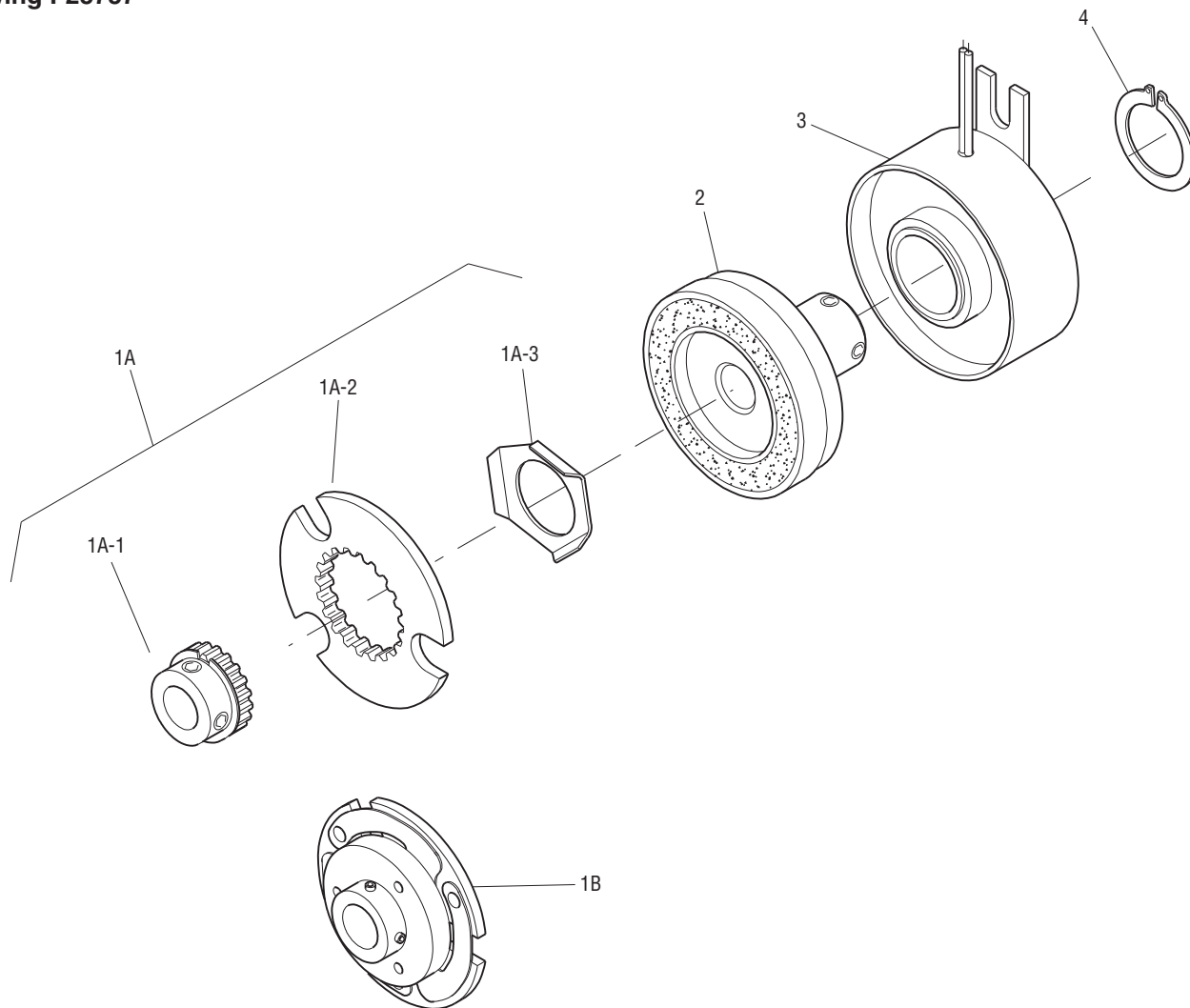

Item	Description	Part Number	Qty.
1A	Armature and Hub		
1A-1	Armature Hub		1
	1/4" Bore	5102-541-002	
	5/16" Bore	5102-541-003	
	3/8" Bore	5102-541-004	
1A-2	Armature	110-0111	1
1A-3	Release Spring	808-0019	1
1B	Antibacklash Armature		1
	1/4" Bore	5623-111-008	
	5/16" Bore	5623-111-009	
	3/8" Bore	5623-111-010	
2	Rotor		1
	1/4" Bore	5603-751-019	
	5/16" Bore	5603-751-021	
	3/8" Bore	5603-751-020	
3	Field		1
	6 Volt	5603-451-039	
	24 Volt	5603-451-041	
	90 Volt	5603-451-043	

Item	Description	Part Number	Qty.
4	Retainer Ring	748-0024	1

### How to Order:

1. Specify Type of Armature Desired.
2. Specify Bore Size for Item 1A-1 or 1B and Item 2.
3. Specify Voltage for Item 3.
4. See Controls Section.

### Example:

SFC-170 Clutch per I-25757 - 90 Volt  
Antibacklash Armature  
1/4" Armature Hub Bore

These units meet standards set forth in UL508 and are listed under guide card #NMTR2, file #59164.

These units are CSA certified under file #LR11543.

Refer to Service Manual P-200.

# Clutch Coupling

## SFC-250 Flange Mounted



For Bore & Keyway sizes see chart below.

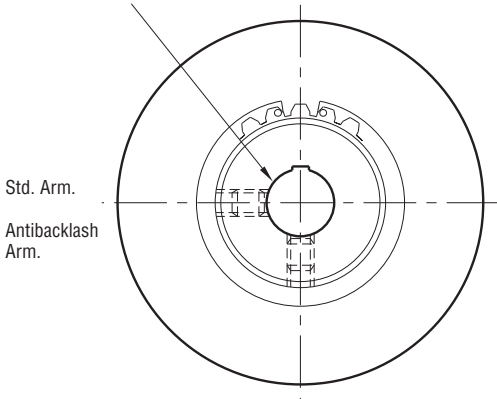

**ARMATURE VIEW**

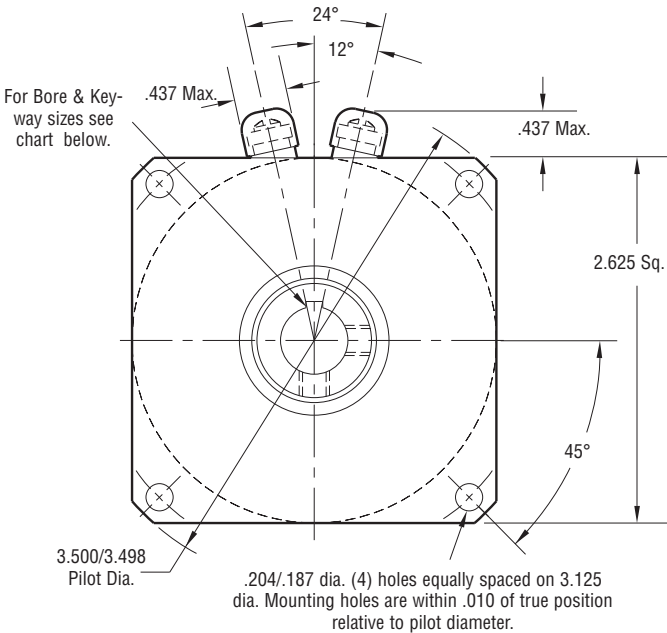

**FIELD VIEW**

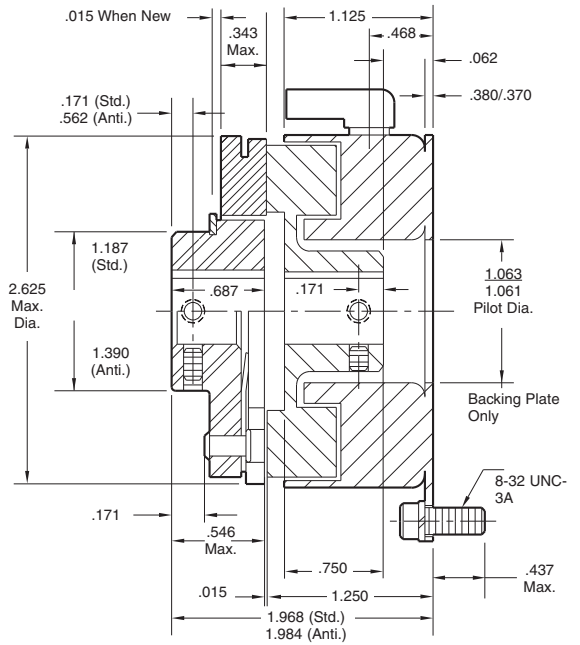

### Bore and Keyway Dimensions

Armature Bore Dia.	Keyway	Rotor Bore Dia.	Keyway
.376/.375	.093 x .046	.376/.375	.093 x .046
*.438/.437	.125 x .062	*.438/.437	.125x .062
.501/.500	.125 x .062	.501/.500	
*.563/.562			
.626/.625			
*.688/.687	.187 x .093		
.751/.750			

\* Available on special order only.

Static Torque	70 lb. in.
Maximum Speed	7,500 rpm
Standard Voltage	D.C. 6, 24, 90

All dimensions are nominal unless otherwise noted.

Information on inertia and weights begins on page 239. Coil data is on pages 250 and 251.

### Customer Shall Maintain:

1. Squareness of field mounting face with rotor shaft within .003 T.I.R. measured at pilot diameter.
2. Concentricity of field mounting pilot diameter with rotor mounting shaft within .003 T.I.R.
3. Rotor and armature shafts in line within .003 T.I.R.



Drawing I-25522

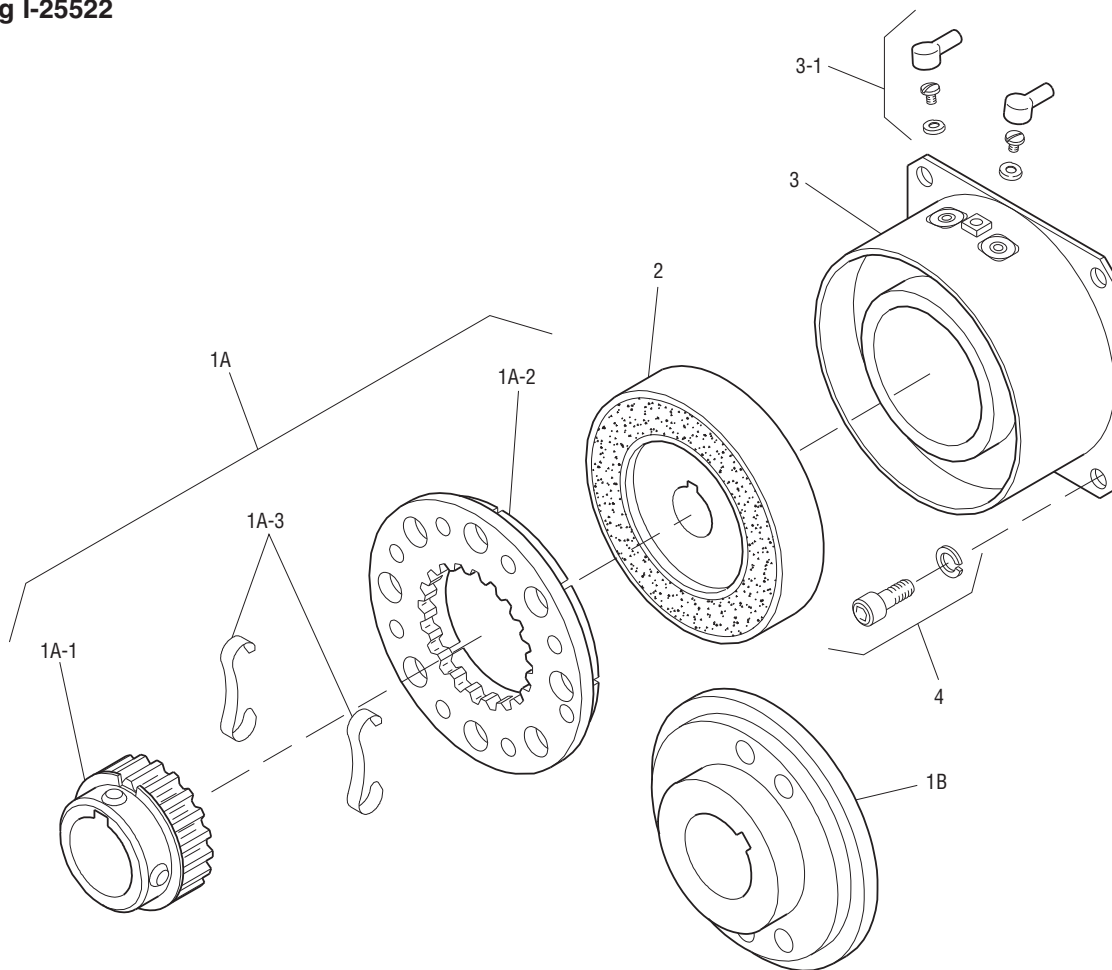

Item	Description	Part Number	Qty.
1A	Armature and Hub		
1A-1	Armature Hub		1
	3/8" Bore	5103-541-002	
	1/2" Bore	5103-541-004	
	5/8" Bore	5103-541-006	
	3/4" Bore	5103-541-008	
1A-2	Armature	5124-111-001	1
1A-3	Release Spring	5103-101-003	1
1B	Antibacklash Armature		1
	3/8" Bore	5365-111-003	
	1/2" Bore	5365-111-005	
	5/8" Bore	5365-111-007	
	3/4" Bore	5365-111-009	
2	Rotor		1
	3/8" Bore	5103-751-008	
	1/2" Bore	5103-751-010	
3	Field		1
	6 Volt	5103-451-002	
	24 Volt	5103-451-004	
	90 Volt	5103-451-007	

Item	Description	Part Number	Qty.
3-1	Terminal Accessory	5103-101-002	1
4	Mounting Accessory	5102-101-001	1

**How to Order:**

1. Specify Type of Armature Desired.
2. Specify Bore Size for Item 1A-1 or 1-B and Item 2.
3. Specify Voltage for Item 3.
4. See Controls Section.

**Example:**

SFC-250 Clutch Coupling per I-25522 - 90 Volt  
 Standard Armature  
 1/2" Armature Hub Bore  
 1/2" Rotor Bore

These units meet standards set forth in UL508 and are listed under guide card #NMTR2, file #59164.

These units are CSA certified under file #LR11543.

Refer to Service Manual P-200.

# Clutch Coupling

## SFC-250 Bearing Mounted

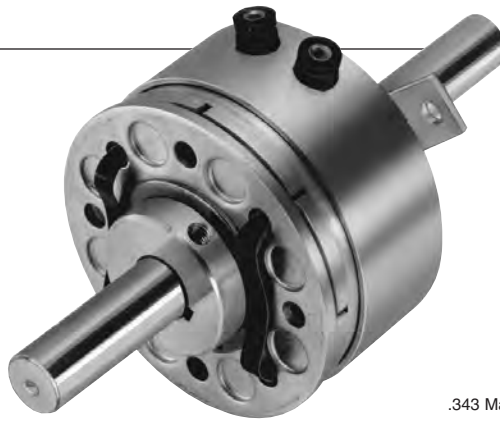

For Bore & Keyway sizes see chart below.

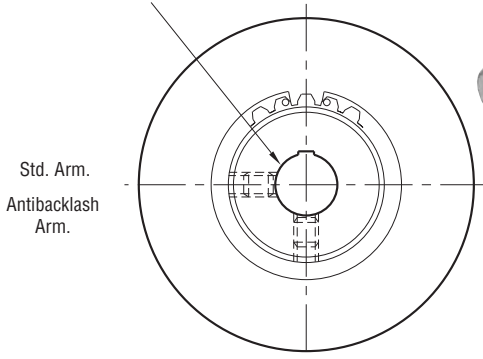

**ARMATURE VIEW**

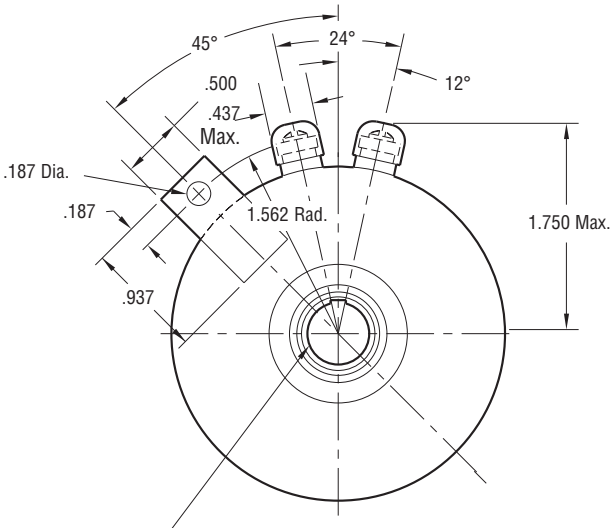

For Bore & Keyway sizes see chart below.

**FIELD VIEW**

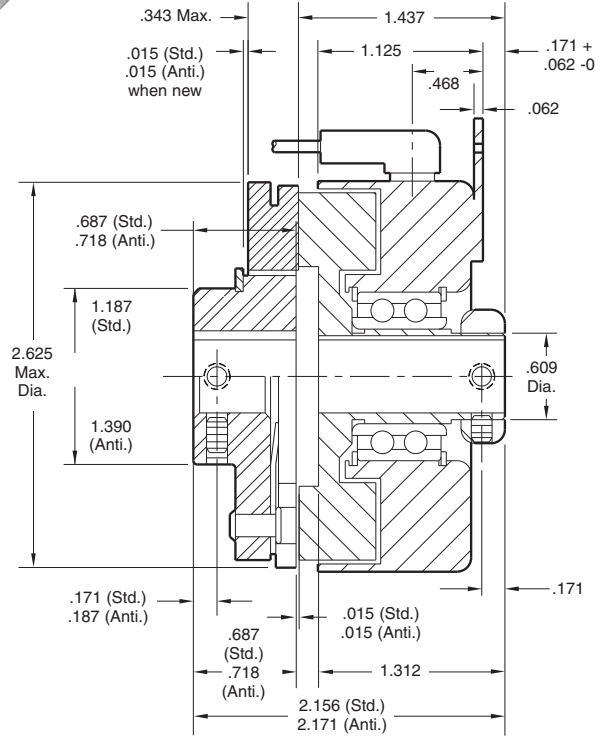

### Bore and Keyway Dimensions

Armature Bore Dia.	Keyway	Rotor Bore Dia.	Keyway
.375/.376	.093 x .046	.376/.375	.093 x .046
*.438/.437	.125 x .062	*.438/.437	.125 x .062
.501/.500		.501/.500	
*.563/.562	.187 x .093		
.626/.625			
*.688/.687			
.751/.750			

\* Available on special order only.

### Customer Shall Maintain:

1. Armature shaft to be concentric with rotor shaft within .003 T.I.R.

Static Torque	70 lb. in.
Maximum Speed	7,500 rpm
Standard Voltage	D.C. 6, 24, 90

All dimensions are nominal unless otherwise noted.

Information on inertia and weights begins on page 239. Coil data is on pages 250 and 251.



Drawing I-25523

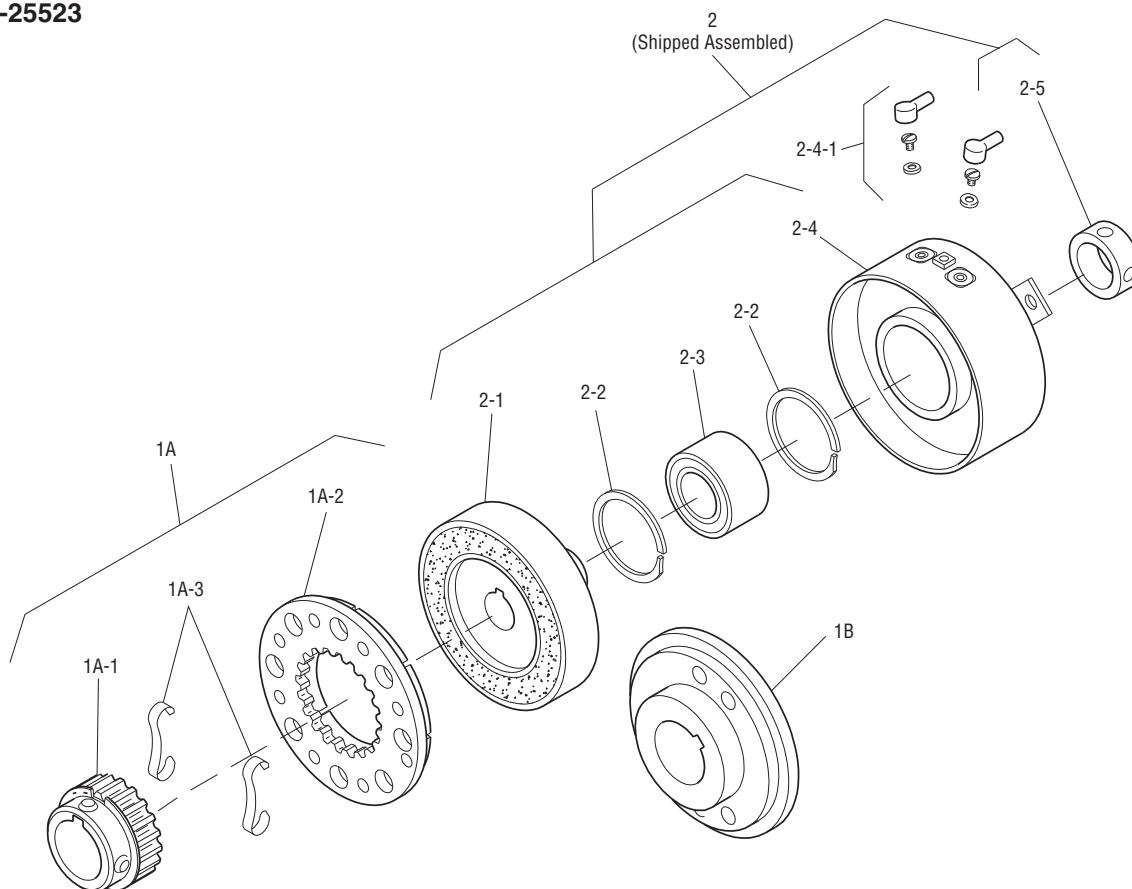

Item	Description	Part Number	Qty.
1A	Armature and Hub		
1A-1	Armature Hub		1
	3/8" Bore	5103-541-002	
	1/2" Bore	5103-541-004	
	5/8" Bore	5103-541-006	
	3/4" Bore	5103-541-008	
1A-2	Armature	5124-111-001	1
1A-3	Release Spring	5103-101-003	1
1B	Antibacklash Armature		1
	3/8" Bore	5365-111-003	
	1/2" Bore	5365-111-005	
	5/8" Bore	5365-111-007	
	3/4" Bore	5365-111-009	
2	Field and Rotor Assembly		1
	6 Volt - 3/8" Bore	5103-452-002	
	24 Volt - 3/8" Bore	5103-452-004	
	90 Volt - 3/8" Bore	5103-452-007	
	6 Volt - 1/2" Bore	5103-452-016	
	24 Volt - 1/2" Bore	5103-452-018	
	90 Volt - 1/2" Bore	5103-452-021	
2-1	Rotor		1
	3/8" Bore	5103-751-014	
	1/2" Bore	5103-751-016	

Item	Description	Part Number	Qty.
2-2	Retainer Ring	748-0371	2
2-3	Ball Bearing	166-0108	1
2-4	Field		1
	6 Volt	5103-451-018	
	24 Volt	5103-451-020	
	90 Volt	5103-451-023	
2-4-1	Terminal Accessory	5103-101-002	1
2-5	Set Collar*	266-0005	1

### How to Order:

1. Specify Type of Armature Desired.
2. Specify Bore Size for Item 1A-1 or 1B and Item 2.
3. Specify Voltage for Item 2.
4. See Controls Section.

### Example:

SFC-250 Clutch Coupling per I-25523 - 90 Volt  
 Standard Armature  
 1/2" Armature Hub Bore  
 1/2" Rotor Bore

These units meet standards set forth in UL508 and are listed under guide card #NMTR2, file #59164. These units are CSA certified under file #LR11543.

\*Used with 1/2" Bore only.

Refer to Service Manual P-200.

# Clutch Coupling

## SFC-400 Flange Mounted

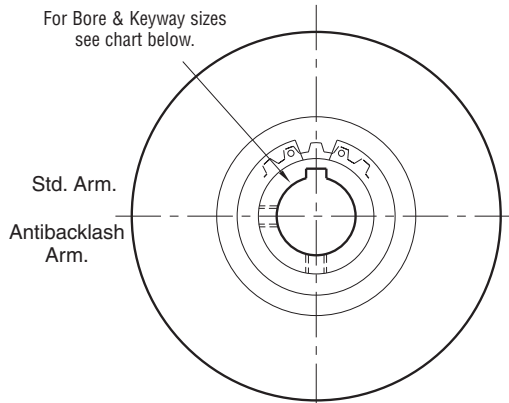

**ARMATURE VIEW**

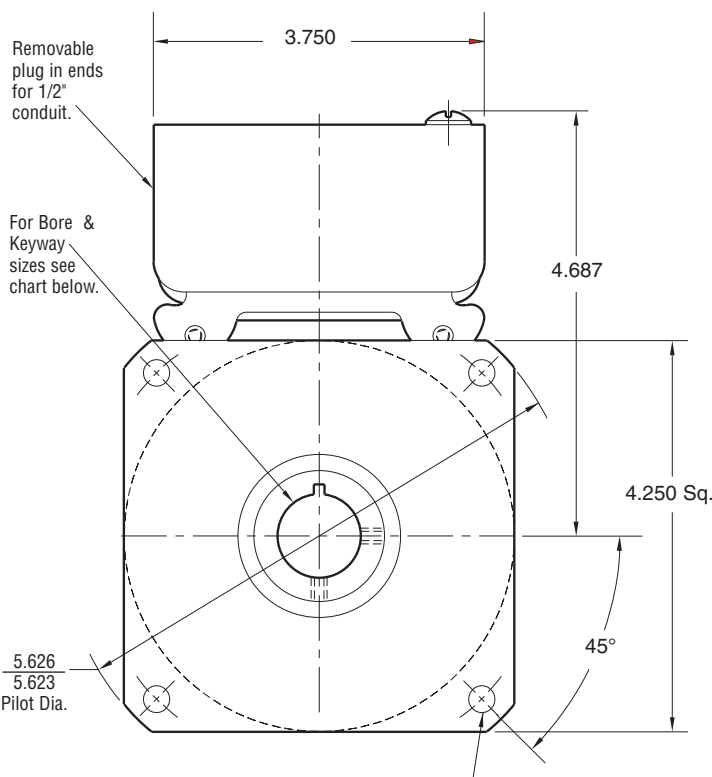

**FIELD VIEW**

\*Mounting holes are within .010 of true position relative to pilot diameter.

### Customer Shall Maintain:

1. Squareness of field mounting face with rotor shaft within .003 T.I.R. measured at pilot diameter.
2. Concentricity of field mounting pilot diameter with rotor mounting shaft within .003 T.I.R.
3. Rotor and armature shafts in line within .003 T.I.R.

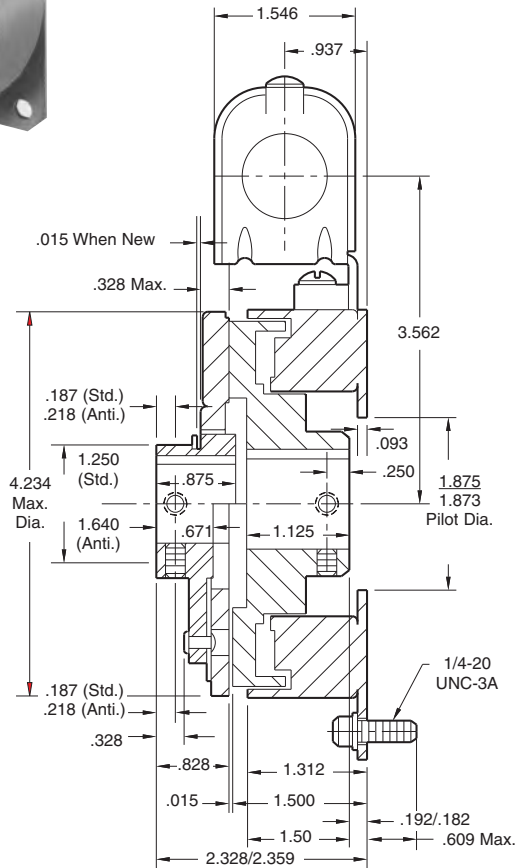

### Bore and Keyway Dimensions

Armature Bore Dia.	Keyway	Rotor Bore Dia.	Keyway
.501/.500	.125 x .062	.501/.500	.125 x .062
*.563/.562			
.626/.625	.187 x .093	.626/.625	.187 x .093
*.688/.687		.751/.750	
.751/.750		.876/.875	
.876/.875		1.001/1.000	

\*Available on special order only

Static Torque	270 lb. in.
Maximum Speed	4,500 rpm
Standard Voltage	D.C. 6, 24, 90

All dimensions are nominal unless otherwise noted.

Information on inertia and weights begins on page 239. Coil data is on pages 250 and 251.





## SFC-400 Flange Mounted

Drawing I-25697

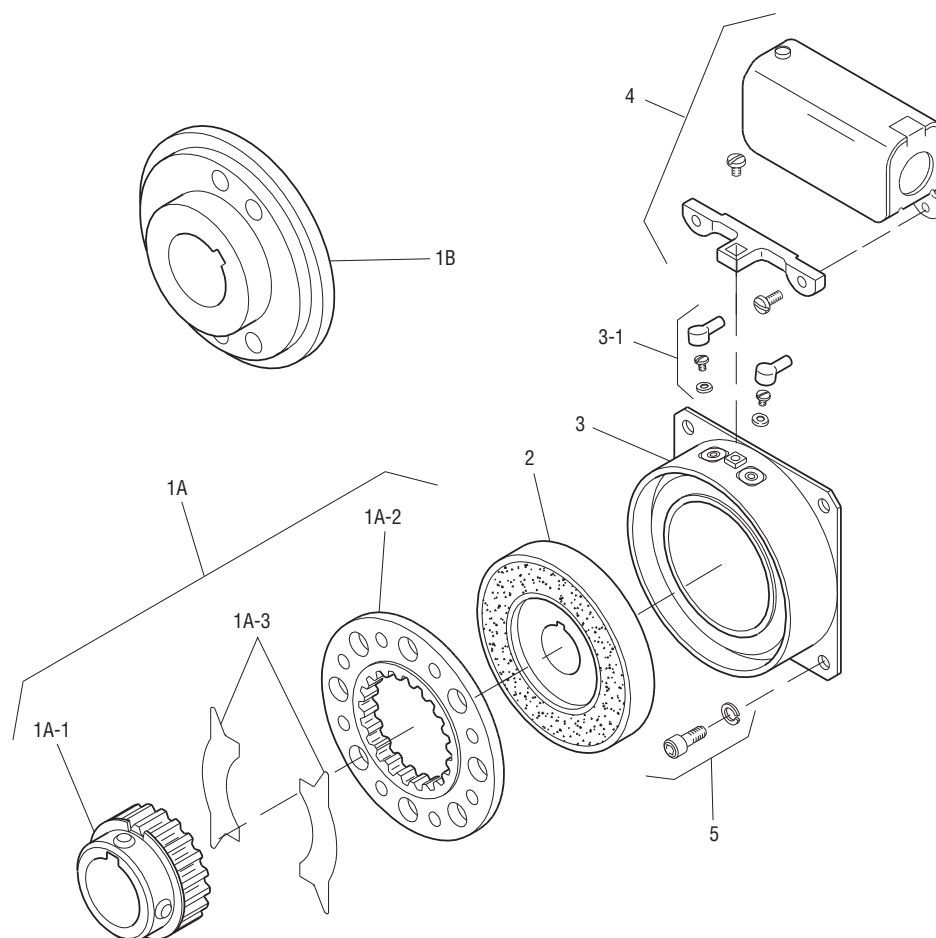

Item	Description	Part Number	Qty.
1A	Armature and Hub		
1A-1	Armature Hub		1
	1/2" Bore	5104-541-002	
	5/8" Bore	5104-541-004	
	3/4" Bore	5104-541-006	
	7/8" Bore	5104-541-007	
1A-2	Armature	5125-111-001	1
1A-3	Release Spring	5104-101-003	1
1B	Antibacklash Armature		1
	1/2" Bore	5367-111-003	
	5/8" Bore	5367-111-005	
	3/4" Bore	5367-111-007	
	7/8" Bore	5367-111-008	
2	Rotor		1
	1/2" Bore	5104-751-033	
	5/8" Bore	5104-751-034	
	3/4" Bore	5104-751-035	
	7/8" Bore	5104-751-036	
	1" Bore	5104-751-037	
3	Field		1
	6 Volt	5104-451-032	
	24 Volt	5104-451-033	
	90 Volt	5104-451-034	

Item	Description	Part Number	Qty.
3-1	Terminal Accessory	5103-101-002	1
4	Conduit Box	5200-101-010	1
5	Mounting Accessory	5104-101-002	1

### How to Order:

1. Specify Type of Armature Desired.
2. Specify Bore Size for Item 1A-1 or 1B and Item 2.
3. Specify Voltage for Item 3.
4. See Controls Section.

### Example:

SFC-400 Clutch Coupling per I-25697 - 90 Volt  
 3/4" Armature Hub Bore  
 3/4" Rotor Bore

These units, when used in conjunction with the correct Warner Electric conduit box, meet standards set forth in UL508 and are listed under guide card #NMTR2, file #59164.

These units are CSA certified under file #LR11543.

Refer to Service Manual P-200.

# Clutch Coupling

## SFC-400 Bearing Mounted



For Bore & Keyway sizes see chart below.

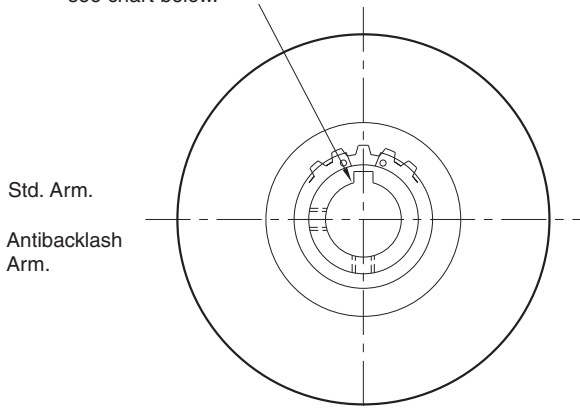

**ARMATURE VIEW**

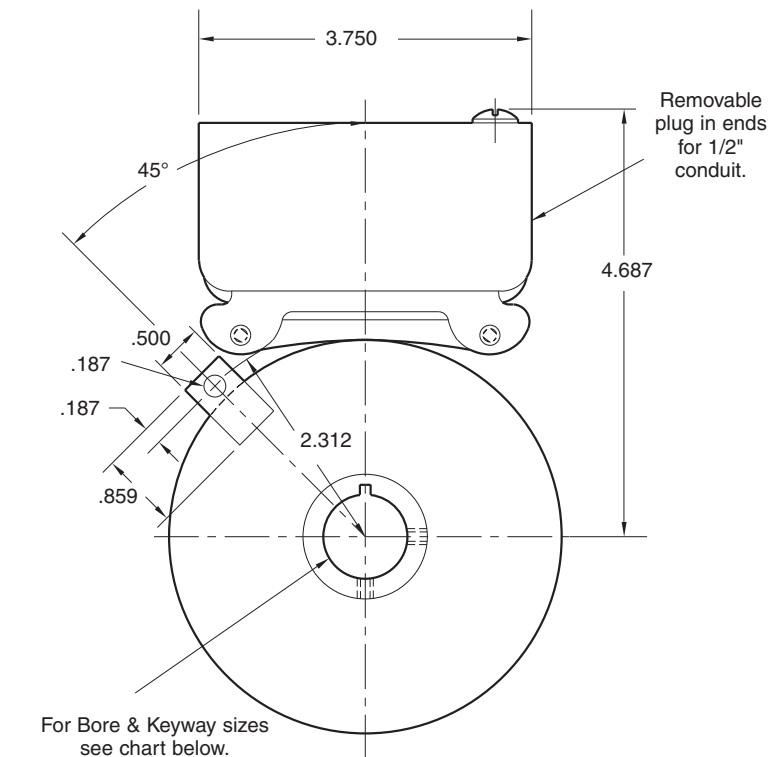

**FIELD VIEW**

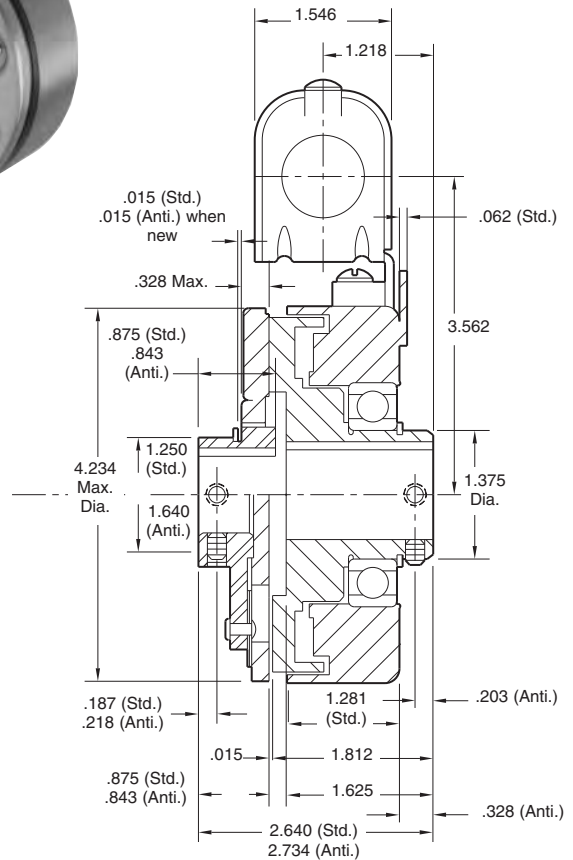

### Bore and Keyway Dimensions

Armature Bore Dia.	Keyway	Rotor Bore Dia.	Keyway
.501/.500 *.563/.562	.125 x .062	.501/.500	.125 x .062
.626/.625 *.688/.687 .751/.750 .876/.875	.187 x .093	.626/.625 .751/.750 .876/.875 1.001/1.000	.187 x .093

\* Available on special order only.

### Customer Shall Maintain:

1. Armature shaft to be concentric with rotor shaft within .003 T.I.R.



Static Torque	270 lb. in.
Maximum Speed	4,500 rpm
Standard Voltage	D.C. 6, 24, 90

All dimensions are nominal unless otherwise noted.

Information on inertia and weights begins on page 239. Coil data is on pages 250 and 251.

## SFC-400 Bearing Mounted

Drawing I-25698

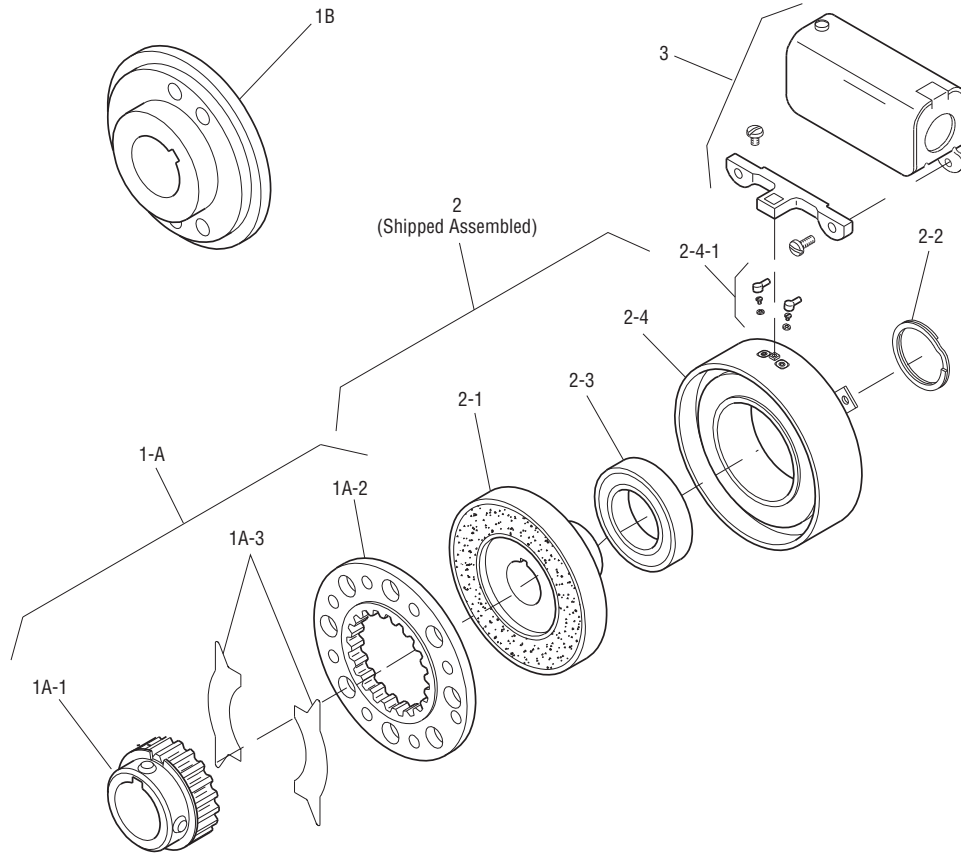

Item	Description	Part Number	Qty.
1A	Armature and Hub		
1A-1	Armature Hub		1
	1/2" Bore	5104-541-002	
	5/8" Bore	5104-541-004	
	3/4" Bore	5104-541-006	
	7/8" Bore	5104-541-007	
1A-2	Armature	5125-111-001	1
1A-3	Release Spring	5104-101-003	1
1B	Antibacklash Armature		1
	1/2" Bore	5367-111-003	
	5/8" Bore	5367-111-005	
	3/4" Bore	5367-111-007	
	7/8" Bore	5367-111-008	
2	Field and Rotor Assembly		1
	6 Volt - 1/2" Bore	5104-452-052	
	24 Volt - 1/2" Bore	5104-452-053	
	90 Volt - 1/2" Bore	5104-452-054	
	6 Volt - 5/8" Bore	5104-452-055	
	24 Volt - 5/8" Bore	5104-452-056	
	90 Volt - 5/8" Bore	5104-452-057	
	6 Volt - 3/4" Bore	5104-452-058	
	24 Volt - 3/4" Bore	5104-452-059	
	90 Volt - 3/4" Bore	5104-452-060	
	6 Volt - 7/8" Bore	5104-452-061	
	24 Volt - 7/8" Bore	5104-452-062	
	90 Volt - 7/8" Bore	5104-452-063	
	6 Volt - 1" Bore	5104-452-064	
	24 Volt - 1" Bore	5104-452-065	
	90 Volt - 1" Bore	5104-452-066	

Item	Description	Part Number	Qty.
2-1	Rotor		1
	1/2" Bore	5104-751-043	
	5/8" Bore	5104-751-044	
	3/4" Bore	5104-751-045	
	7/8" Bore	5104-751-046	
	1" Bore	5104-751-047	
2-2	Retainer Ring	748-0018	1
2-3	Ball Bearing	166-0150	1
2-4	Field		1
	6 Volt	5104-451-038	
	24 Volt	5104-451-039	
	90 Volt	5104-451-040	
2-4-1	Terminal Accessory	5103-101-002	1
3	Conduit Box	5200-101-010	1

### How to Order:

1. Specify Type of Armature Desired.
2. Specify Bore Size for Item 1A-1 or 1-B and Item 2.
3. Specify Voltage for Item 2.
4. See Controls Section.

### Example:

SFC-400 Clutch Coupling per  
 I-25698 - 90 Volt  
 Antibacklash Armature  
 3/4" Armature Hub Bore  
 3/4" Rotor Bore

These units meet standards set forth in UL508 and are listed under guide card #NMTR2, file #59164. These units are CSA certified under file #LR11543.

Refer to Service Manual P-200.

# Clutch Coupling

**Normal Duty**

## SFC-500 Bearing Mounted



See page 252 for details on Bushings & keyways.

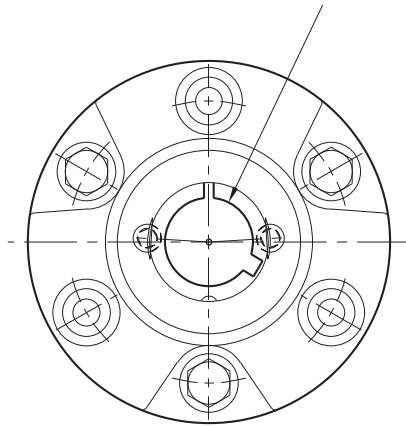

**HUB VIEW**

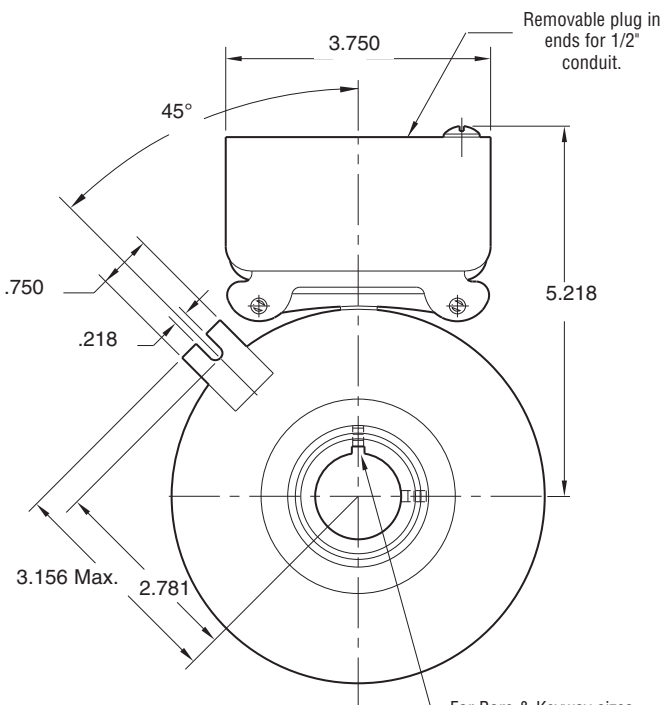

**FIELD VIEW**

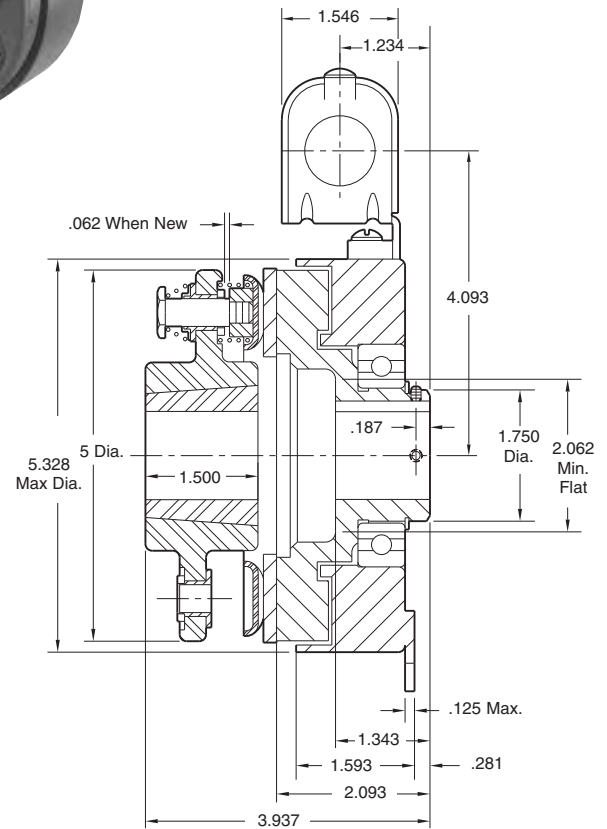

### Bore & Keyway Dimensions

Rotor Bore Dia.	Keyway
.751/.750	.187 x .093
.876/.875	
.9385/.9375	
1.001/1.000	.250 x .125
1.126/1.125	
1.251/1.250	

Armature Shaft	.500 – 1.250
Rotor Shaft	.750 – 1.250
Static Torque	50 lb.ft.
Maximum Speed	4,000 rpm
Standard Voltage	D.C. 6, 24, 90

### Customer Shall Maintain:

1. Armature mounting shaft to be concentric with rotor mounting shaft within .006 T.I.R.



All dimensions are nominal unless otherwise noted.

Information on inertia and weights begins on page 239. Coil data is on pages 250 and 251.

## SFC-500 Bearing Mounted

Drawing I-25540

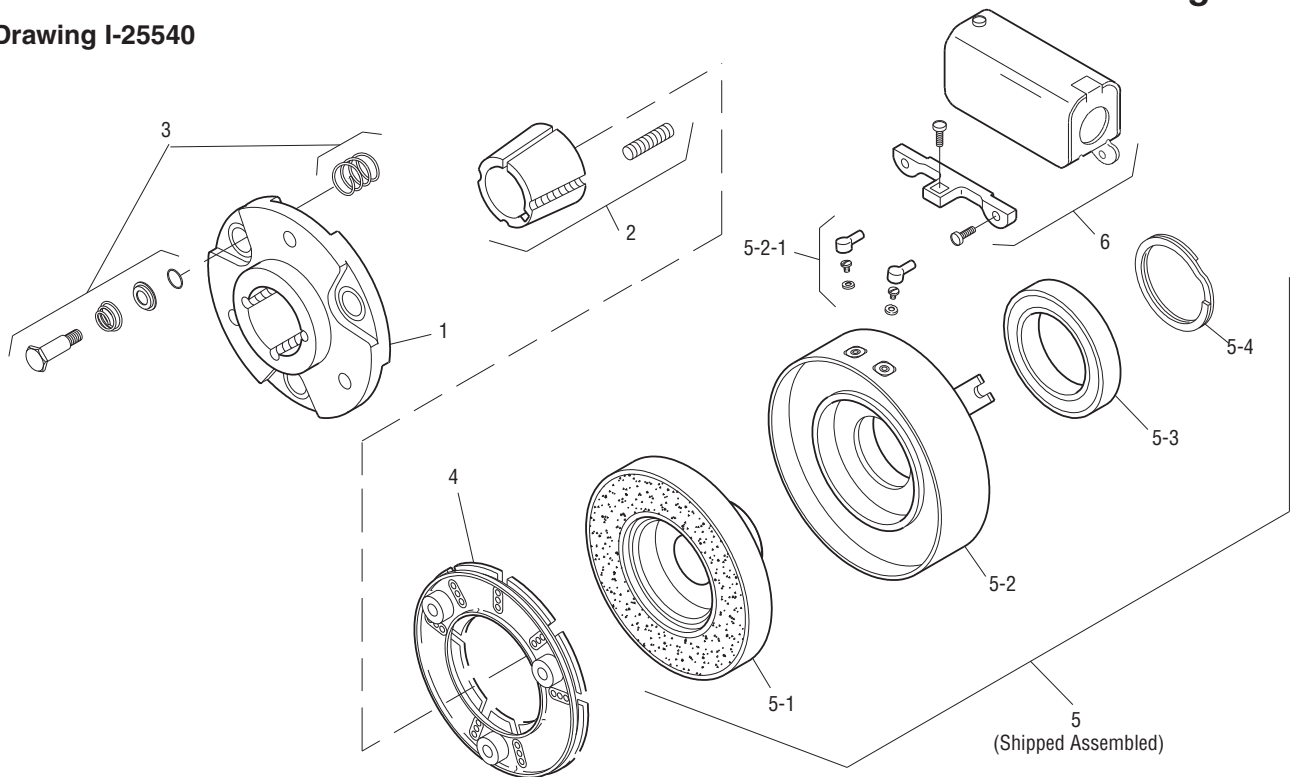

Item	Description	Part Number	Qty.
1	Armature Hub	5300-541-004	1
2	Bushing*		1
	1/2" to 1 1/4" Bore	180-0116 to 180-0128	
3	Autogap Accessory	5200-101-009	3
4	Armature	5300-111-002	1
5	Field and Rotor Assembly		1
	6 Volt – 3/4" Bore	5200-452-002	
	24 Volt – 3/4" Bore	5200-452-004	
	90 Volt – 3/4" Bore	5200-452-005	
	6 Volt – 7/8" Bore	5200-452-008	
	24 Volt – 7/8" Bore	5200-452-010	
	90 Volt – 7/8" Bore	5200-452-011	
	24 Volt – 15/16" Bore	5200-452-016	
	90 Volt – 15/16" Bore	5200-452-017	
	6 Volt – 1" Bore	5200-452-020	
	24 Volt – 1" Bore	5200-452-022	
	90 Volt – 1" Bore	5200-452-023	
	6 Volt – 1-1/8" Bore	5200-452-026	
	24 Volt – 1-1/8" Bore	5200-452-028	
	90 Volt – 1-1/8" Bore	5200-452-029	
	6 Volt – 1-1/4" Bore	5200-452-032	
	24 Volt – 1-1/4" Bore	5200-452-034	
	90 Volt – 1-1/4" Bore	5200-452-035	
5-1	Rotor		1
	3/4" Bore	5200-751-002	
	7/8" Bore	5200-751-003	
	15/16" Bore	5200-751-004	

Item	Description	Part Number	Qty.
	1" Bore	5200-751-005	
	1-1/8" Bore	5200-751-006	
	1-1/4" Bore	5200-751-007	
5-2	Field & Bearing Assembly		1
	6 Volt	5200-451-024	
	24 Volt	5200-451-026	
	90 Volt	5200-451-027	
5-2-1	Terminal Accessory	5311-101-001	1
5-3	Ball Bearing	166-0110	1
5-4	Retainer Ring	748-0002	1
6	Conduit Box	5200-101-010	1

### How to Order:

1. Specify Bore Size for Item 2 and Item 5.
2. Specify Voltage for Item 5.
3. See Controls Section.

### Example:

SFC-500 Clutch Coupling per I-25540 - 90 Volt  
3/4" Bores

These units, when used in conjunction with the correct Warner Electric conduit box, meet the standards set of UL508 and are listed under guide card #NMTR2, file #59164.

These units are CSA certified under file #LR11543

\*See page 252 for specific part numbers.

Refer to Service Manual P-202.

## SFC-500 Bearing Mounted

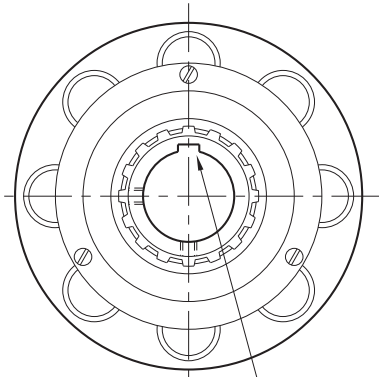

For Bore & Keyway sizes see chart below.

### ARMATURE VIEW

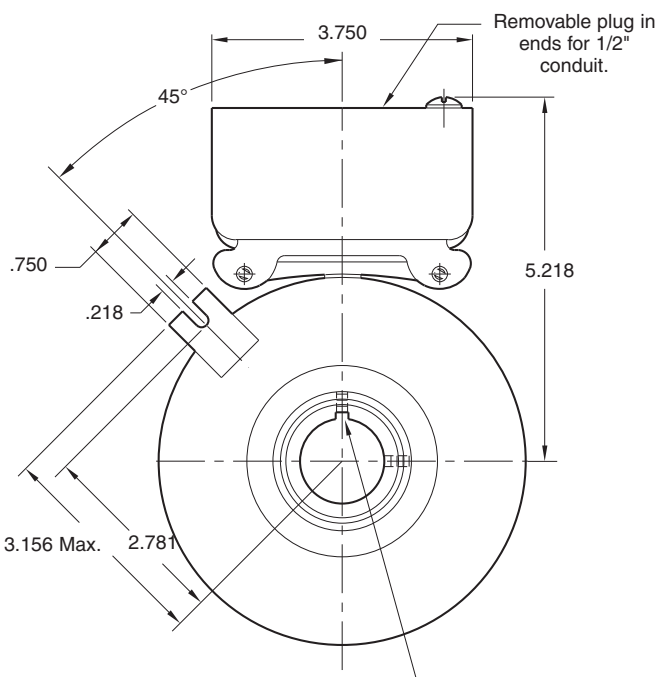

For Bore & Keyway sizes see chart below.

### FIELD VIEW

#### Customer Shall Maintain:

1. Angular alignment of shafts within 1/2 degree.
2. Armature mounting shaft to be concentric with rotor mounting shaft within .006 T.I.R.

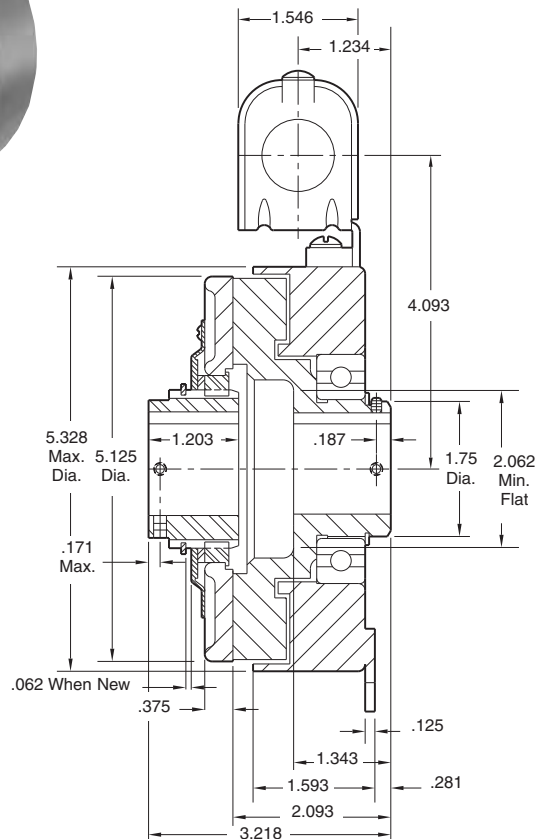

### Bore & Keyway Dimensions

Bore Dia.	Keyway
.751/.750 .876/.875	.187 x .093
.9385/.9375 1.001/1.000 1.126/1.125 1.251/1.250	.250 x .125

Armature Shaft	.750 – 1.250
Rotor Shaft	.750 – 1.250
Static Torque	50 lb.ft.
Maximum Speed	4,000 rpm
Standard Voltage	D.C. 6, 24, 90

All dimensions are nominal unless otherwise noted.

Information on inertia and weights begins on page 239. Coil data is on pages 250 and 251.



## SFC-500 Bearing Mounted

Drawing I-25541

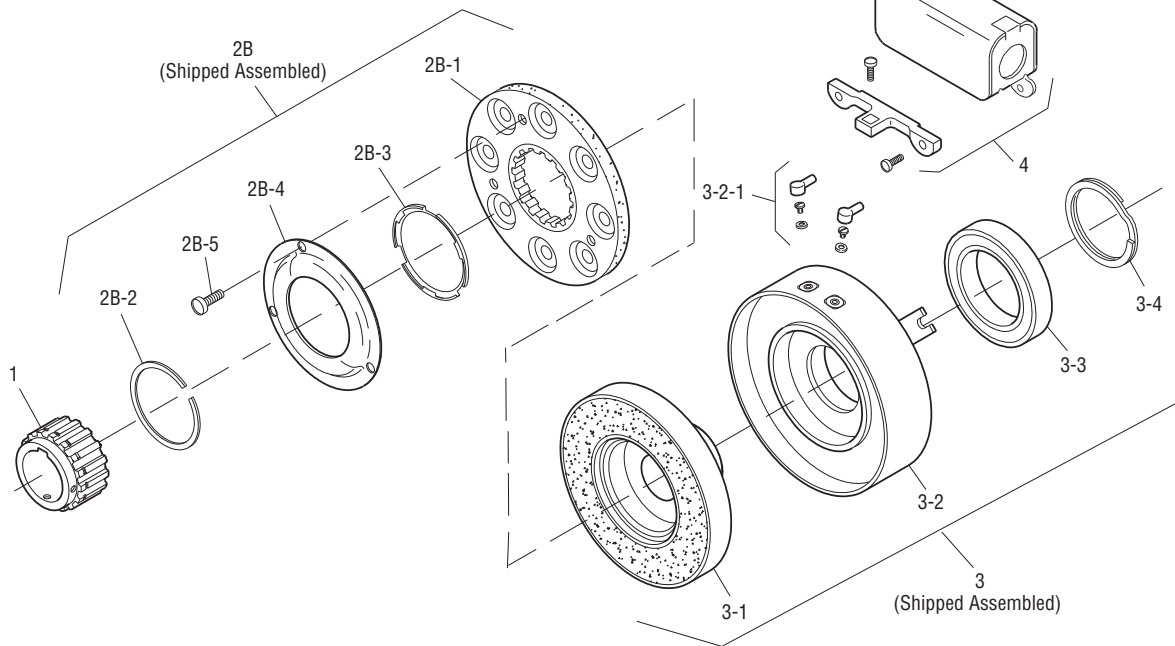

Item	Description	Part Number	Qty.
1	Armature Hub Assembly		1
	3/4" Bore	5200-541-002	
	7/8" Bore	5200-541-003	
	15/16" Bore	5200-541-004	
	1" Bore	5200-541-005	
	1-1/8" Bore	5200-541-006	
	1-1/4" Bore	5200-541-007	
2B	Armature Assembly w/Autogap	5230-111-002	1
2B-1	Armature	5230-111-001	1
2B-2	Retainer Ring	748-0355	1
2B-3	Autogap Spring	808-0412	1
2B-4	Retainer Plate	748-0364	1
2B-5	Screw	797-0028	3
3	Field and Rotor Assembly		1
	6 Volt – 3/4" Bore	5200-452-002	
	24 Volt – 3/4" Bore	5200-452-004	
	90 Volt – 3/4" Bore	5200-452-005	
	6 Volt – 7/8" Bore	5200-452-008	
	24 Volt – 7/8" Bore	5200-452-010	
	90 Volt – 7/8" Bore	5200-452-011	
	24 Volt – 15/16" Bore	5200-452-016	
	90 Volt – 15/16" Bore	5200-452-017	
	6 Volt – 1" Bore	5200-452-020	
	24 Volt – 1" Bore	5200-452-022	
	90 Volt – 1" Bore	5200-452-023	
	6 Volt – 1-1/8" Bore	5200-452-026	
	24 Volt – 1-1/8" Bore	5200-452-028	
	90 Volt – 1-1/8" Bore	5200-452-029	
	6 Volt – 1-1/4" Bore	5200-452-032	
	24 Volt – 1-1/4" Bore	5200-452-034	
	90 Volt – 1-1/4" Bore	5200-452-035	

Item	Description	Part Number	Qty.
3-1	Rotor		1
	3/4" Bore	5200-751-002	
	7/8" Bore	5200-751-003	
	15/16" Bore	5200-751-004	
	1" Bore	5200-751-005	
	1-1/8" Bore	5200-751-006	
	1-1/4" Bore	5200-751-007	
3-2	Field & Bearing Assembly		1
	6 Volt	5200-451-024	
	24 Volt	5200-451-026	
	90 Volt	5200-451-027	
3-2-1	Terminal Accessory	5311-101-001	1
3-3	Ball Bearing	166-0110	1
3-4	Retainer Ring	748-0002	1
4	Conduit Box	5200-101-010	1

### How to Order:

1. Specify Bore Size for Item 1 and Item 3.
2. Specify Voltage for Item 3.
3. See Controls Section.

### Example:

SFC-500 Clutch Coupling per I-25541- 90 Volt  
3/4" Armature Hub Bore  
7/8" Rotor Bore

These units, when used in conjunction with the correct Warner Electric conduit box, meet standards set forth in UL508 and are listed under guide card #NMTR2, file #59164.

These units are CSA certified under file #LR11543

Refer to Service Manual P-202.

# Clutch Coupling

## SFC-650 Flange Mounted

See page 252 for details on Bushings.

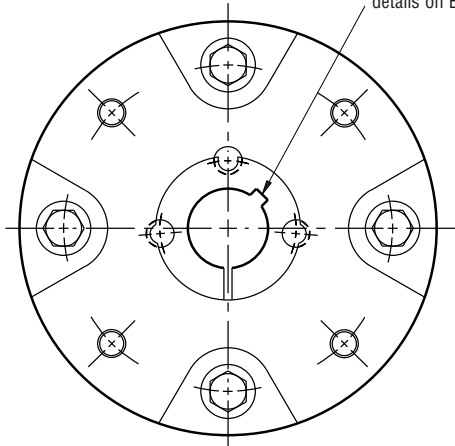

**HUB VIEW**

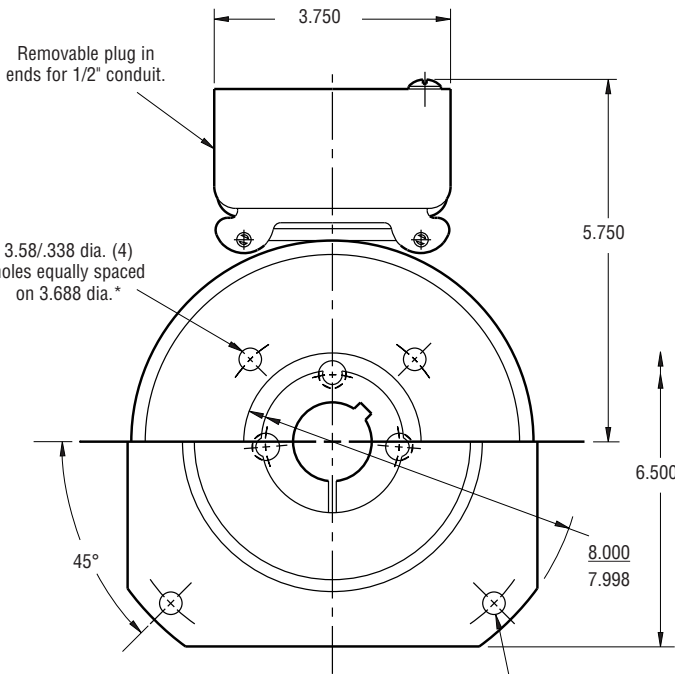

**FIELD VIEW**  
(Inside & Outside Mounted)

### Customer Shall Maintain:

1. Concentricity of field mounting pilot diameter with rotor mounting shaft within .006 T.I.R.
2. Squareness of field mounting face with shaft within .006 T.I.R. measured at field mounting bolt circle.
3. Rotor mounting pilot diameter must be concentric with shaft within .006 T.I.R.
4. Armature mounting shaft to be concentric with rotor mounting shaft within .006 T.I.R.

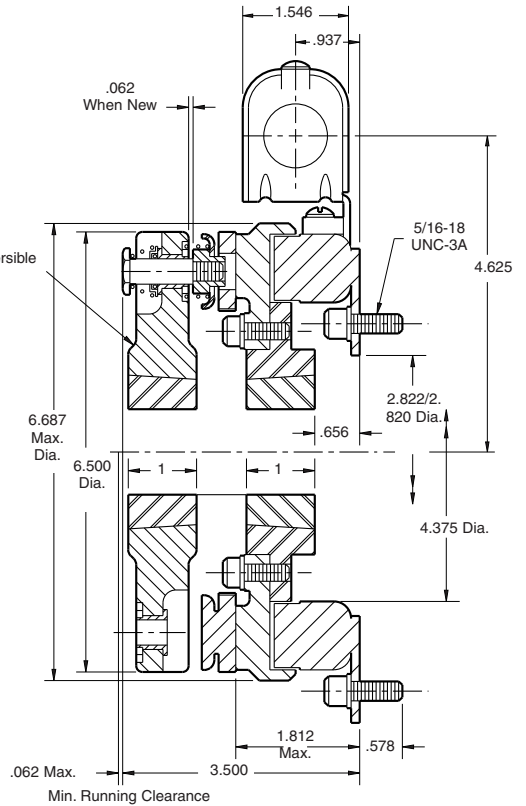

\* Mounting holes are within .010 of true position relative to pilot diameter.

Armature Shaft	.500 – 1.625
Rotor Shaft	.500 – 1.625
Static Torque	95 lb.ft.
Maximum Speed	3,600 rpm
Standard Voltage	D.C. 6, 24, 90

All dimensions are nominal unless otherwise noted.

Information on inertia and weights begins on page 239. Coil data is on pages 250 and 251.



Drawing I-25728

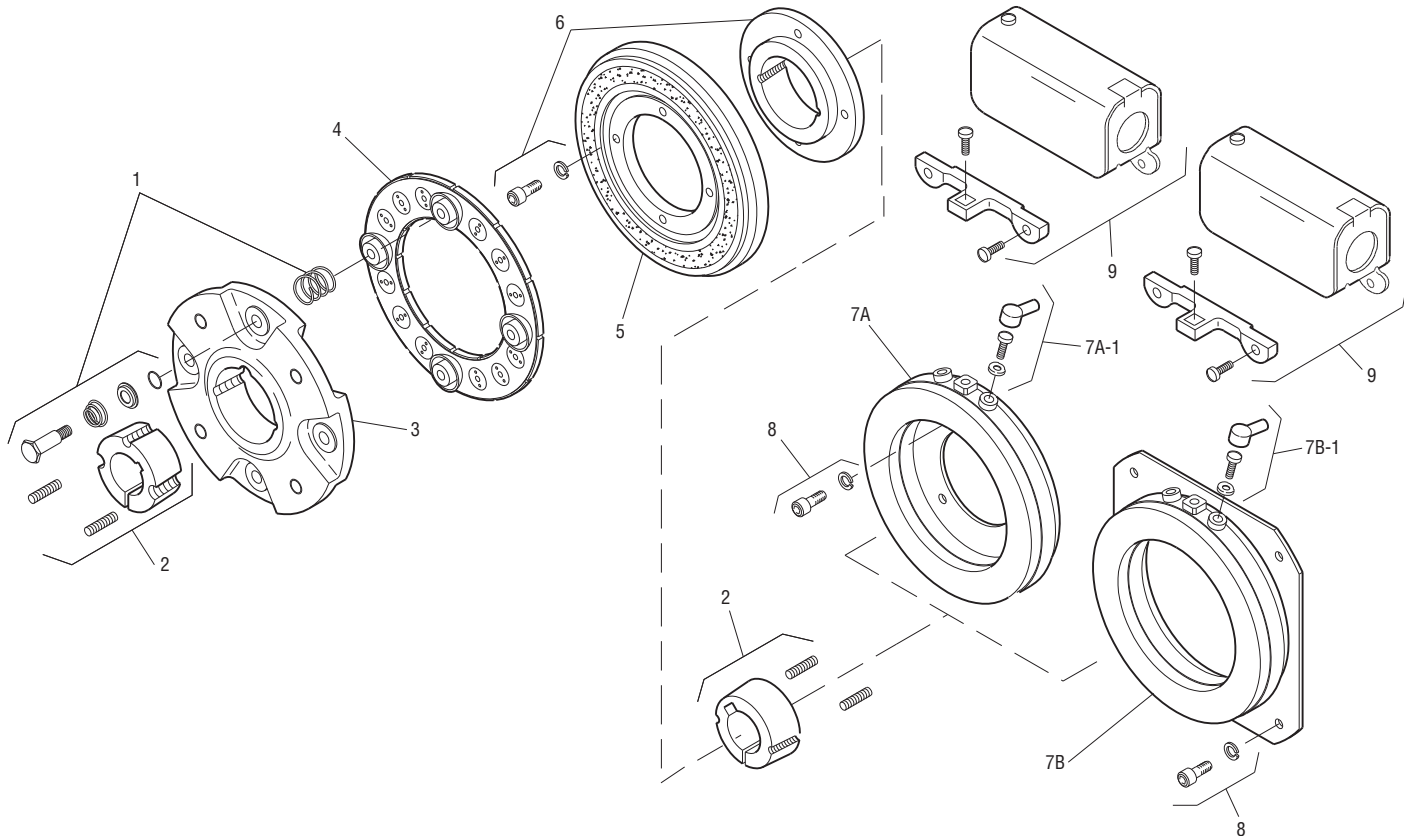

Item	Description	Part Number	Qty.
1	Autogap Accessory	5181-101-010	4
2	Bushing*		2
	1/2" to 1-5/8" Bore	180-0326 to 180-0344	1
3	Armature Hub	5207-541-002	1
4	Armature	5281-111-002	1
5	Rotor	5281-751-001	1
6	Rotor Hub & Mounting Accessory	5207-101-005	1
7A	Field - Inside Mounted		1
	6 Volt	5207-451-009	
	24 Volt	5207-451-012	
	90 Volt	5207-451-011	
7A-1	Terminal Accessory	5311-101-001	1
7B	Field - Outside Mounted		1
	6 Volt	5207-451-003	
	24 Volt	5207-451-006	
	90 Volt	5207-451-005	
7B-1	Terminal Accessory	5311-101-001	1

Item	Description	Part Number	Qty.
8	Mounting Accessory	5321-101-002	1
9	Conduit Box	5200-101-010	1

### How to Order:

1. Specify Bore Size for Item 2 (both shafts).
2. Specify Voltage for Item 7.
3. Specify Inside or Outside Mounted for Item 7.
4. See Controls Section.

### Example:

SFC-650 Clutch Coupling  
Flange Mounted per I-25728 - 90 Volt  
1" Bore

These units, when used in conjunction with the correct Warner Electric conduit box, meet the standards of UL508 and are listed under guide card #NMTR, file #59164.

These units are CSA certified under file #LR11543.

\*See page 252 for specific part numbers.

Refer to Service Manual P-202.

# Clutch Coupling

## SFC-650 Bearing Mounted



See page 252 for details on Bushings.

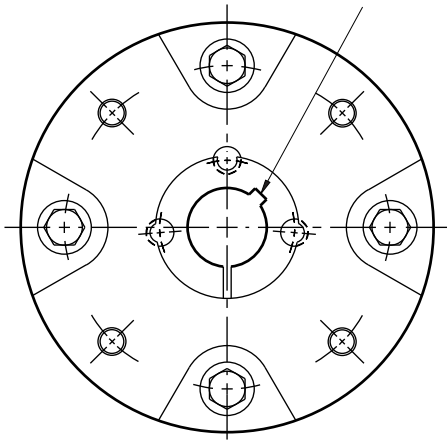

**HUB VIEW**

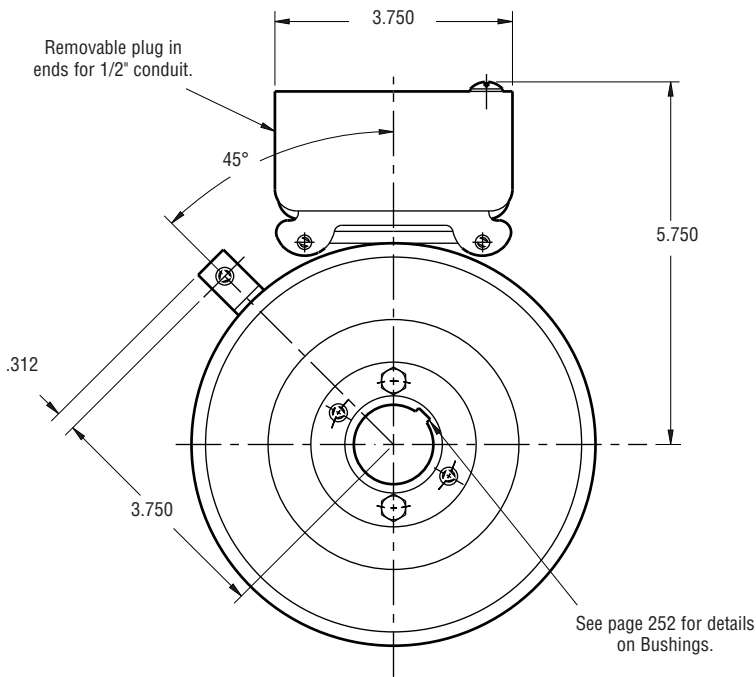

**FIELD VIEW**

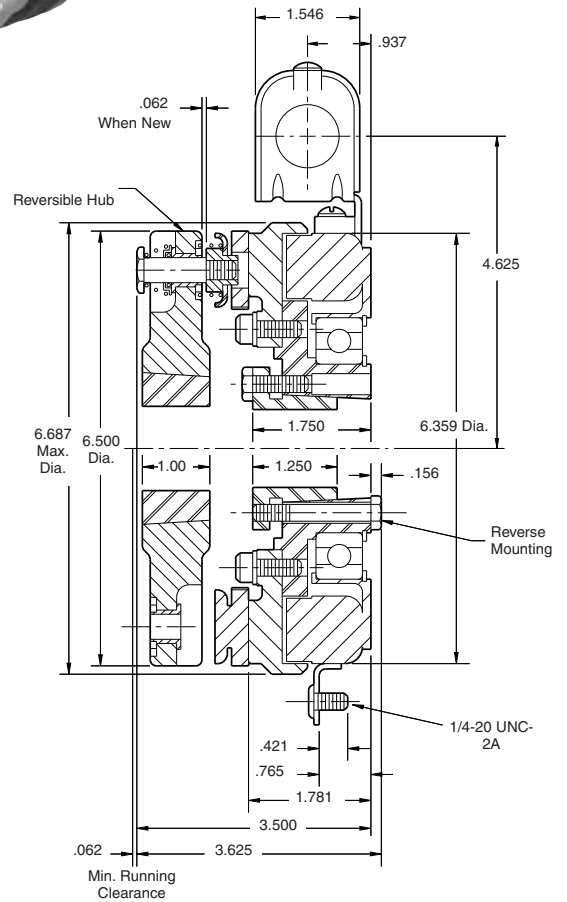

Armature Shaft	.500 – 1.625
Rotor Shaft	.500 – 1.500
Static Torque	95 lb.ft.
Maximum Speed	3,600 rpm
Standard Voltage	D.C. 6, 24, 90

All dimensions are nominal unless otherwise noted.

Information on inertia and weights begins on page 239. Coil data is on pages 250 and 251.

### Customer Shall Maintain:

1. Armature mounting shaft to be concentric with rotor mounting shaft within .006 T.I.R.



Drawing I-25729

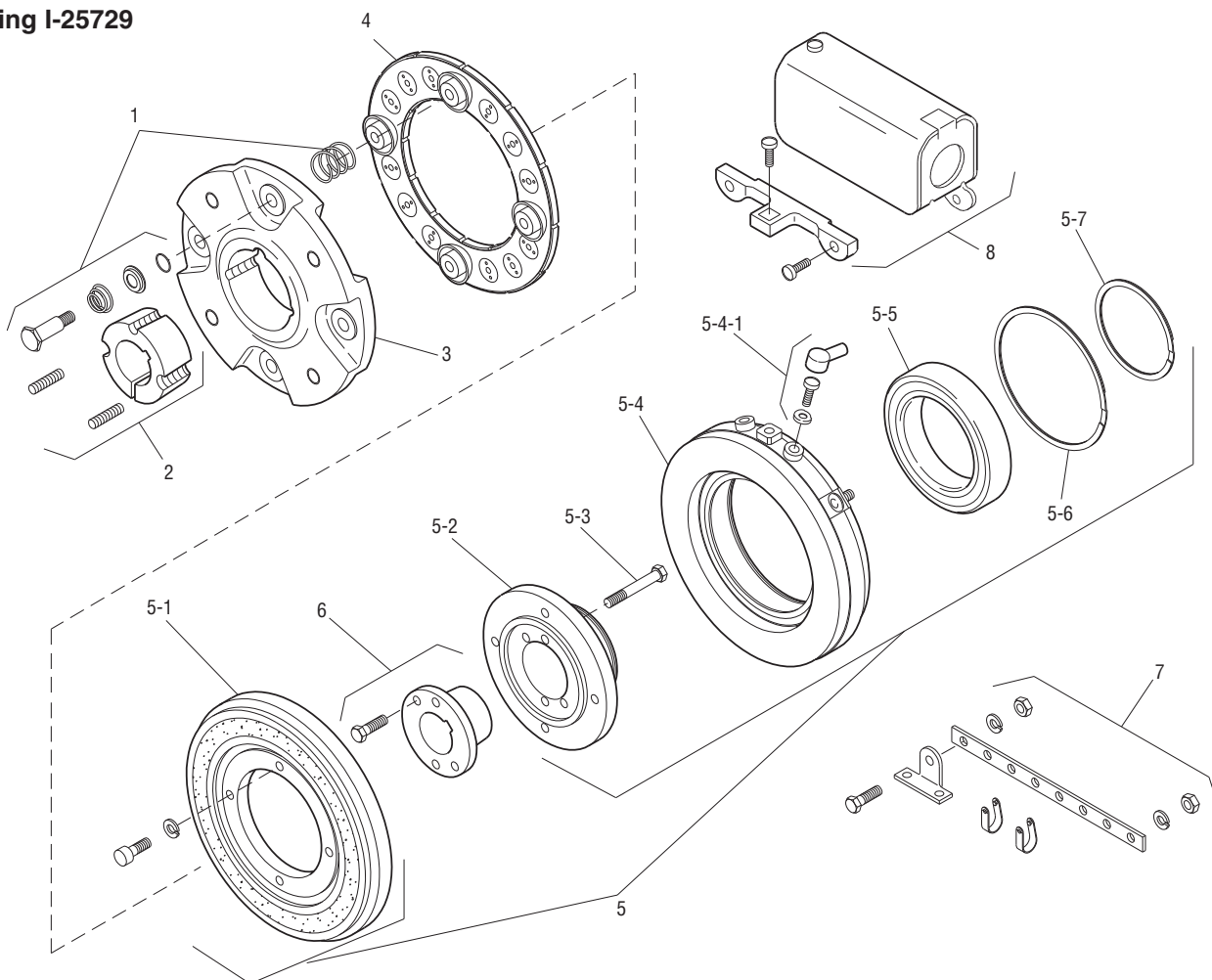

Item	Description	Part Number	Qty.
1	Autogap Accessory	5181-101-010	4
2	Bushing*		1
	1/2" to 1-5/8" Bore	180-0326 to 180-0344	
3	Armature Hub	5207-541-002	1
4	Armature	5281-111-002	1
5	Field and Rotor Assembly		1
	6 Volt	5207-452-002	
	24 Volt	5207-452-005	
	90 Volt	5207-452-004	
5-1	Rotor Assembly	5281-751-001	1
5-2	Rotor Hub	540-0614	1
5-3	Reverse Mounting Accessory	5201-101-005	1
5-4	Field Assembly		1
	6 Volt	5281-451-002	
	24 Volt	5281-451-004	
	90 Volt	5281-451-005	
5-4-1	Terminal Accessory	5311-101-001	1
5-5	Ball Bearing	166-0104	1
5-6	Retainer Ring - Exterior	748-0004	1

Item	Description	Part Number	Qty.
5-7	Retainer Ring - Interior	748-0104	1
6	Bushing*		1
	1/2" to 1-1/2" Bore	180-0002 to 180-0018	
†7	Torque Arm Accessory	5207-101-003	1
8	Conduit Box	5200-101-010	1

### How to Order:

1. Specify Bore Size of Item 2 and Item 6.
2. Specify Voltage for Item 5.
3. See Controls Section.

### Example:

SFC-650 Clutch Coupling,  
Bearing Mounted per I-25729 - 90 Volt, 1" Bore

These units, when used in conjunction with the correct Warner Electric conduit box, meet the standards of UL508 and are listed under guide card #NMTR, file #59164.

These units are CSA certified under file #LR11543

\*See page 252 for specific part numbers.

Refer to Service Manual P-202.

†Optional – not included in price.

# Clutch Coupling

## SFC-825 Flange Mounted



See page 252 for details on Bushings.

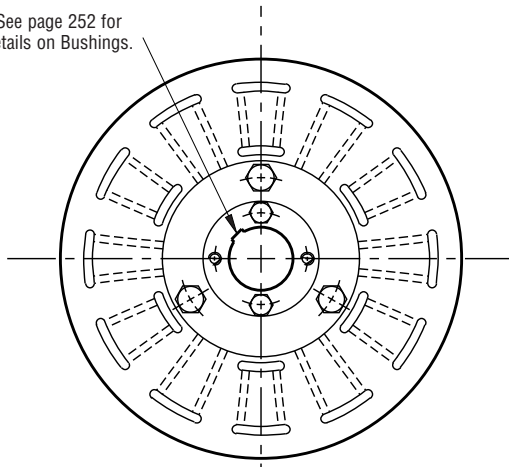

**ARMATURE VIEW**

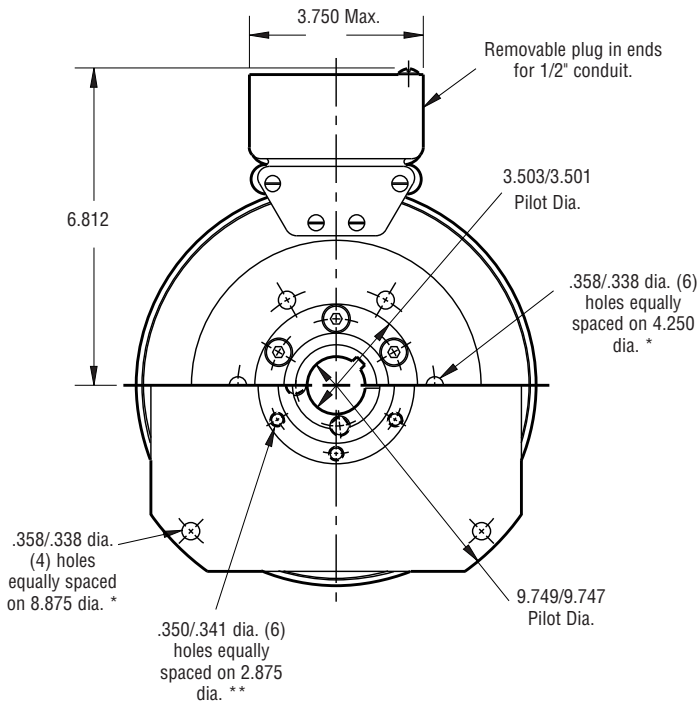

**FIELD VIEW**

(Inside & Outside Mounted)

### Customer Shall Maintain:

1. Concentricity of field mounting pilot diameter with rotor mounting shaft within .006 T.I.R.
2. Squareness of field mounting face with rotor shaft within .006 T.I.R. measured at field mounting bolt circle.
3. Rotor mounting shaft concentric with armature mounting shaft within .006 T.I.R.
4. Angular alignment of shafts within 1/2 degree.

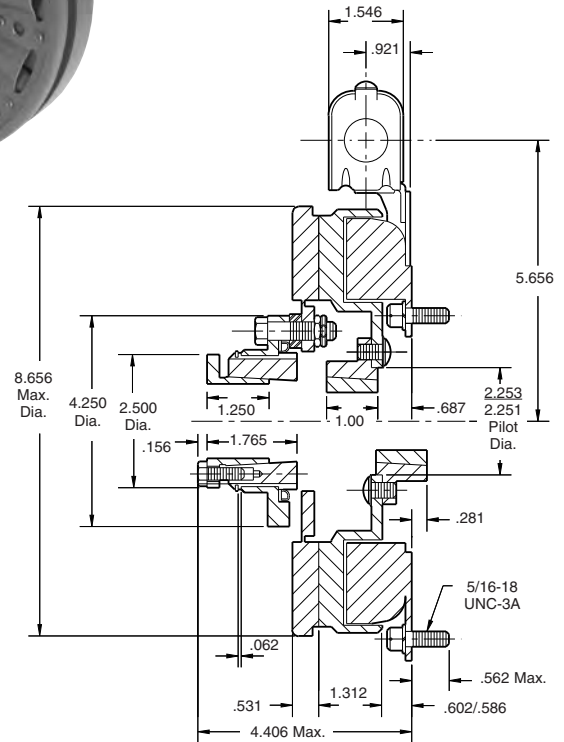

\* Mounting holes are within .010 of true position relative to pilot diameter.

\*\* Mounting holes are within .008 of true position relative to pilot diameter.

Armature Shaft	.500 – 1.500
Rotor Shaft	.500 – 1.250
Static Torque	125 lb. ft.
Maximum Speed	4,000 rpm
Standard Voltage	D.C. 6, 24, 90

All dimensions are nominal unless otherwise noted.

Information on inertia and weights begins on page 239. Coil data is on pages 250 and 251.

**Note:** The two mating shafts on which the clutch is mounted must be mounted rigidly to prevent flexing during engagement. Any flexing will cause vibration and rapid clutchwear. The drive motor should not be mounted on the reducer "scoop" mount or other flexible mounts.

Drawing I-25564

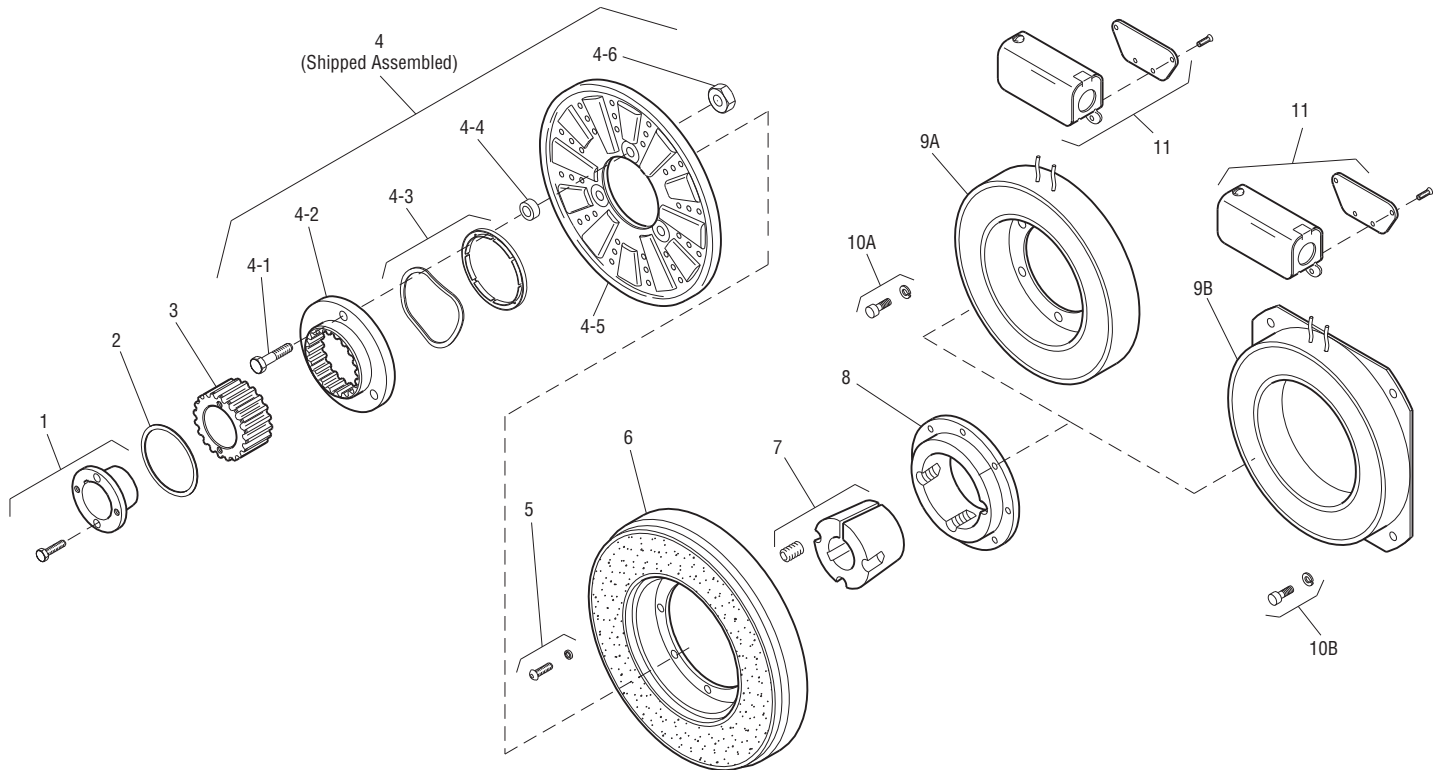

Item	Description	Part Number	Qty.
1	Bushing*		1
	1/2" to 1-1/2" Bore	180-0002 to 180-0018	
2	Retainer Ring	748-0006	1
3	Splined Hub	540-0057	1
4	Armature & Splined Adapter	5201-111-001	1
4-1	Capscrew	797-0341	3
4-2	Splined Adapter	104-0008	1
4-3	Autogap Accessory	5321-101-006	1
4-4	Spacer	748-0333	3
4-5	Armature	5321-111-022	1
4-6	Locknut	661-0004	3
5	Mounting Accessory	5201-101-007	1
6	Rotor		1
	Standard Friction Material	5201-751-003	
	†Optional LK Facing	5201-751-007	
7	Bushing*		1
	1/2" to 1-1/4" Bore	180-0101 to 180-0013	
8	Rotor Hub	540-0013	1
9A	Field - Inside Mounted		1
	6 Volt	5201-451-006	
	24 Volt	5201-451-008	
	90 Volt	5201-451-010	

Item	Description	Part Number	Qty.
9B	Field - Outside Mounted		1
	6 Volt	5201-451-014	
	24 Volt	5201-451-016	
	90 Volt	5201-451-018	
10A	Mounting Accessory - I.M.	5321-101-001	1
10B	Mounting Accessory - O.M.	5321-101-002	1
11	Conduit Box	5200-101-012	1

### How to Order:

1. Specify Bore Size for Item 1.
2. Specify Bore Size for Item 7.
3. Specify Voltage for Item 9A or 9B.
4. Specify Inside Mounted for Items 9A and 10A or Outside Mounted for Items 9B and 10B.
5. See Controls Section.

### Example:

SFC-825 Clutch Coupling per I-25564 - 90 Volt, Inside Mounted, 1" Bore (Item 1), 1" Bore (Item 7)

These units, when used in conjunction with the correct Warner Electric conduit box, meet standards of UL508 and are listed under guide card #NMTR, file #59164. These units are CSA certified under file #LR11543.

\*See page 252 for specific part numbers.

Refer to Service Manual P-207.

†Optional LK facing available. For more information, see page 232.

# Clutch Coupling

## SFC-825 Bearing Mounted



See page 252 for details on Bushings.

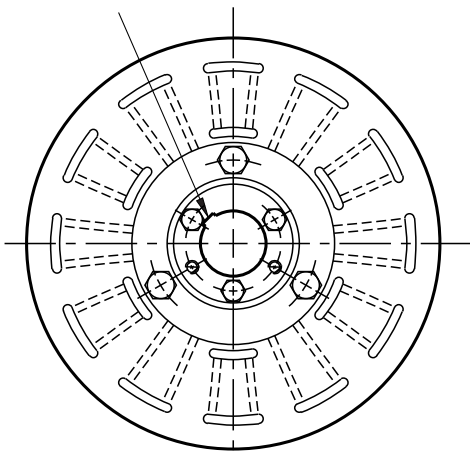

**ARMATURE VIEW**

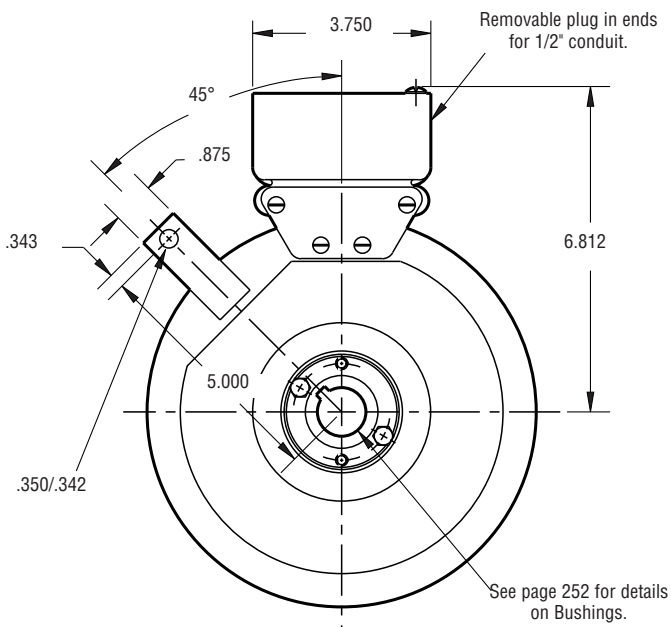

**FIELD VIEW**

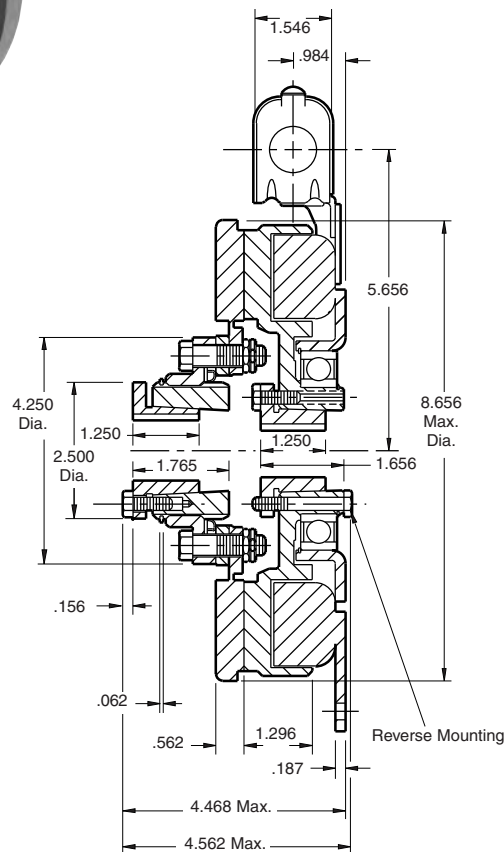

Armature Shaft	.500 – 1.500
Rotor Shaft	.500 – 1.500
Static Torque	150 lb. ft.
Maximum Speed	3,600 rpm
Standard Voltage	D.C. 6, 24, 90

All dimensions are nominal unless otherwise noted.

Information on inertia and weights begins on page 239. Coil data is on pages 250 and 251.

### Customer Shall Maintain:

1. Armature mounting shaft concentric with field and rotor mounting shaft within .006 T.I.R.
2. Angular alignment of shafts within 1/2 degree.



Drawing I-25574

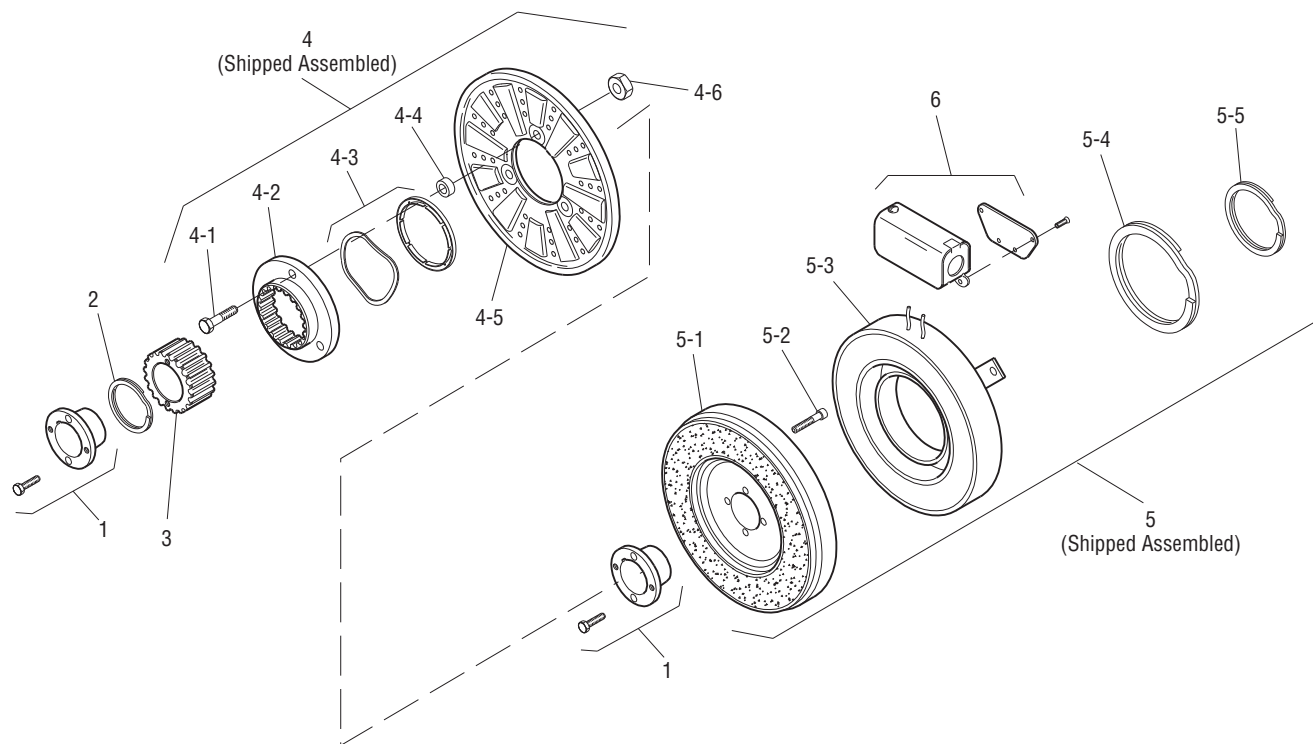

Item	Description	Part Number	Qty.
1	Bushing*		2
	1/2" to 1-1/2" Bore	180-0002 to 180-0018	
2	Retainer Ring	748-0006	1
3	Splined Hub	540-0057	1
4	Armature & Splined Adapter	5201-111-001	1
4-1	Capscrew	797-0341	3
4-2	Splined Adapter	104-0008	1
4-3	Autogap Accessory	5321-101-006	1
4-4	Spacer	748-0333	3
4-5	Armature	5321-111-022	1
4-6	Locknut	661-0004	3
5	Field & Rotor Assembly		1
	6 Volt	5201-452-002	
	24 Volt	5201-452-004	
	90 Volt	5201-452-006	
5-1	Rotor		1
	Standard Friction Material	5201-751-008	
5-2	Mounting Accessory	5201-101-005	1
5-3	Field		1
	6 Volt	5201-451-054	
	24 Volt	5201-451-056	
	90 Volt	5201-451-057	

Item	Description	Part Number	Qty.
5-4	Retainer Ring	748-0111	1
5-5	Retainer Ring	748-0016	1
6	Conduit Box	5200-101-012	1

### How to Order:

1. Specify Bore Size for Item 1 (both shafts).
2. Specify Voltage for Item 5.
3. See Controls Section.

### Example:

SFC-825 Clutch Coupling per I-25574 - 90 Volt, 1" Bore

These units, when used in conjunction with the correct Warner Electric conduit box, meet the standards of UL508 and are listed under guide card #NMTR, file #59164. These units are CSA certified under file #LR11543.

\*See page 252 for specific part numbers.

Refer to Service Manual P-207.

# Clutch Coupling

## SFC-1000 Flange Mounted



See page 252 for details on Bushings.

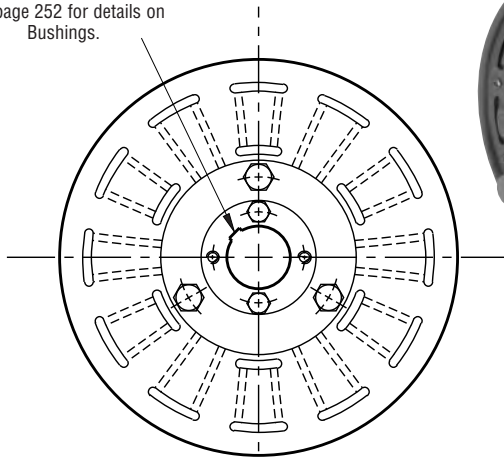

**ARMATURE VIEW**

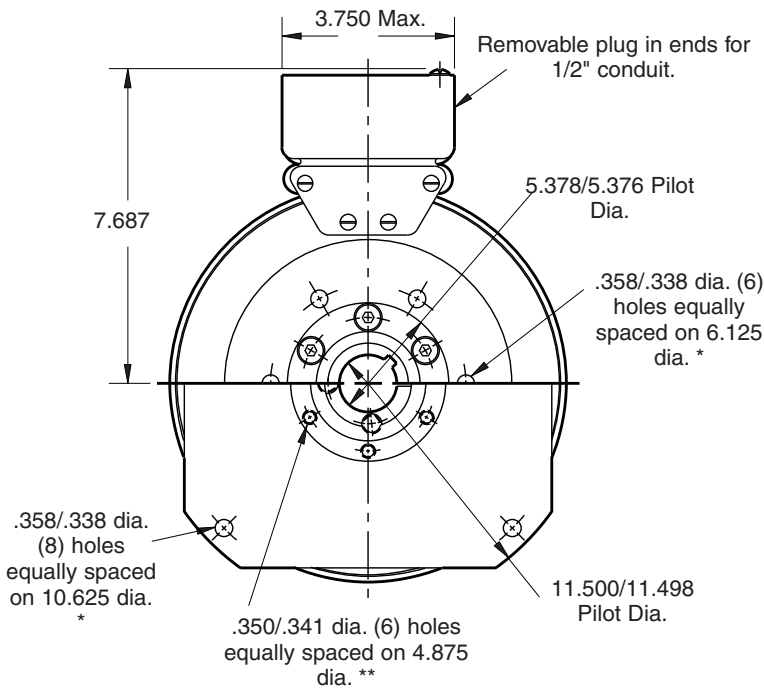

**FIELD VIEW**  
(Inside & Outside Mounted)

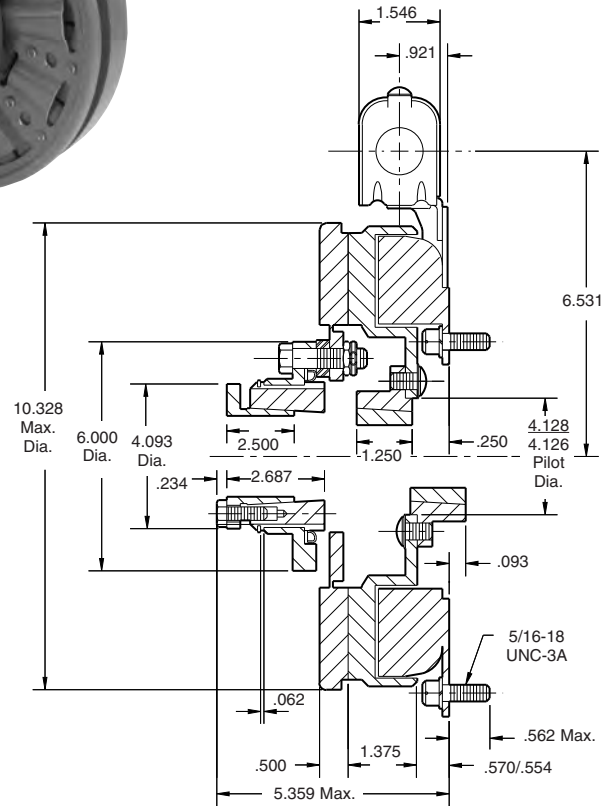

\* Mounting holes are within .010 of true position relative to pilot diameter.

\*\* Mounting holes are within .008 of true position relative to pilot diameter.

Armature Shaft	.750 – 2.687
Rotor Shaft	.500 – 2.000
Static Torque	240 lb. ft.
Maximum Speed	3,600 rpm
Standard Voltage	D.C. 6, 24, 90

All dimensions are nominal unless otherwise noted.

Information on inertia and weights begins on page 239. Coil data is on pages 250 and 251.

**Note:** The two mating shafts on which the clutch is mounted must be mounted rigidly to prevent flexing during engagement. Any flexing will cause vibration and rapid clutchwear. The drive motor should not be mounted on the reducer "scoop" mount or other flexible mounts.

### Customer Shall Maintain:

1. Concentricity of field mounting pilot diameter with rotor mounting shaft within .006 T.I.R.
2. Squareness of field mounting face with rotor shaft within .006 T.I.R. measured at field mounting bolt circle.
3. Rotor mounting shaft concentric with armature mounting shaft within .006 T.I.R.
4. Angular alignment of shafts within 1/2 degree.





Drawing I-25584

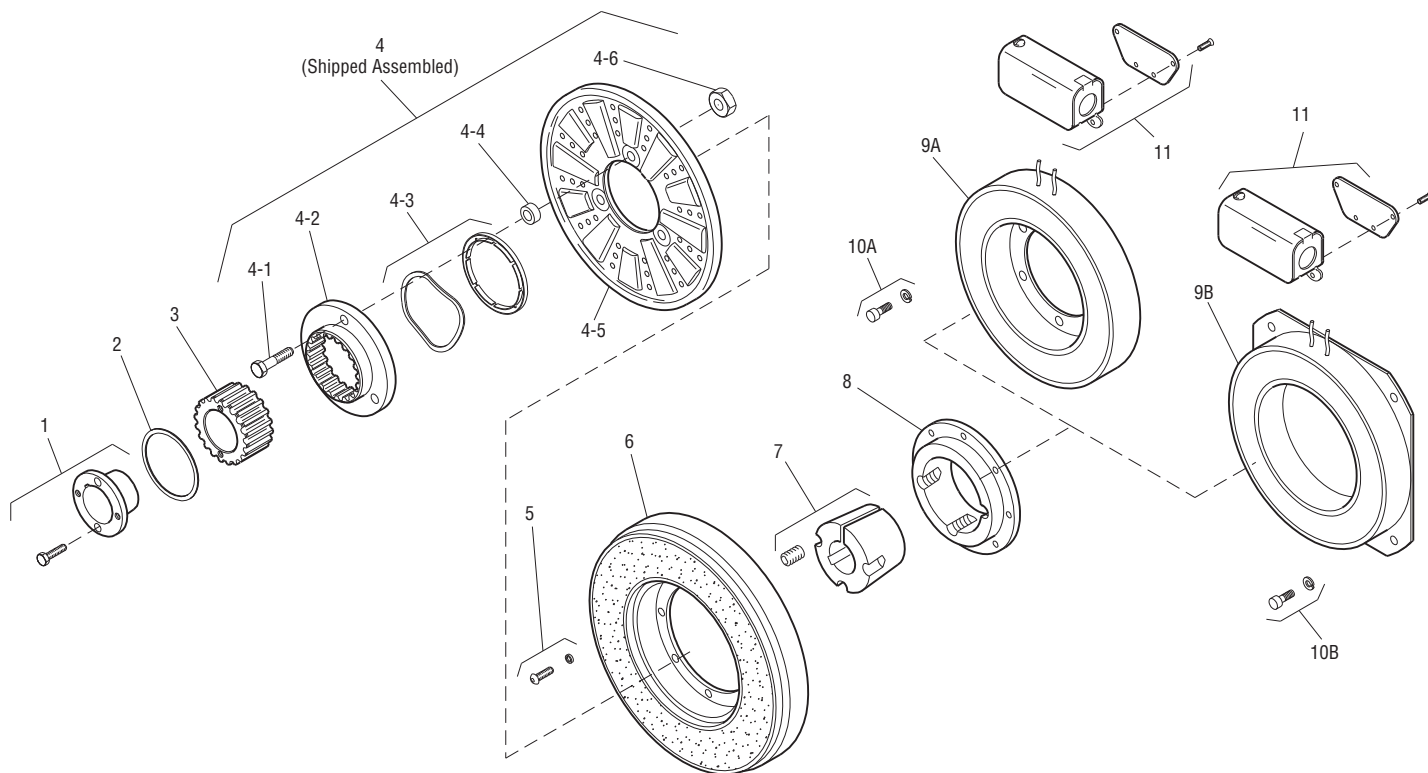

Item	Description	Part Number	Qty.
1	Bushing*		1
	3/4" to 2-11/16" Bore	180-0026 to 180-0057	
2	Retainer Ring	748-0007	1
3	Splined Hub	540-0062	1
4	Armature & Splined Adapter	5202-111-001	1
4-1	Capscrew	797-0341	3
4-2	Splined Adapter	104-0009	1
4-3	Autogap Accessory	5322-101-004	1
4-4	Spacer	748-0333	3
4-5	Armature	5322-111-036	1
4-6	Locknut	661-0004	3
5	Mounting Accessory	5201-101-007	1
6	Rotor		1
	Standard Friction Material	5202-751-003	
	†Optional LK Facing	5202-751-007	
7	Bushing*		1
	1/2" to 2" Bore	180-0155 to 180-0179	
8	Rotor Hub	540-0315	1
9A	Field - Inside Mounted		1
	6 Volt	5202-451-004	
	24 Volt	5202-451-006	
	90 Volt	5202-451-007	

Item	Description	Part Number	Qty.
9B	Field - Outside Mounted		1
	6 Volt	5202-451-011	
	24 Volt	5202-451-013	
	90 Volt	5202-451-014	
10A	Mounting Accessory - I.M.	5321-101-001	1
10B	Mounting Accessory - O.M.	5321-101-002	2
11	Conduit Box	5200-101-012	1

**How to Order:**

1. Specify Bore Size for Item 1.
2. Specify Bore Size for Item 7.
3. Specify Voltage for Item 9A or 9B.
4. Specify Inside Mounted for Items 9A and 10A or Outside Mounted for Items 9B and 10B.
5. See Controls Section.

**Example:**

SFC-1000 Clutch Coupling per I-25584 - 90 Volt, Inside Mounted, 1-1/4" Bore (Item 1), 1-1/2" Bore (Item 7)

These units, when used in conjunction with the correct Warner Electric conduit box, meet standards of UL508 and are listed under guide card #NMTR, file #59164. These units are CSA certified under file #LR11543.

\*See page 252 for specific part numbers.

Refer to Service Manual P-207.

†Optional LK facing available. For more information, see page 232.

# Clutch Coupling

## SFC-1000 Bearing Mounted



See page 252 for details on Bushings.

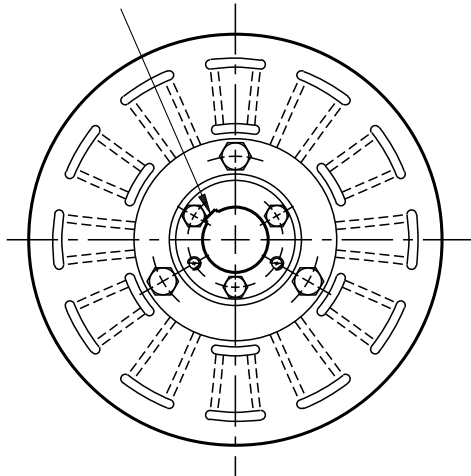

**ARMATURE VIEW**

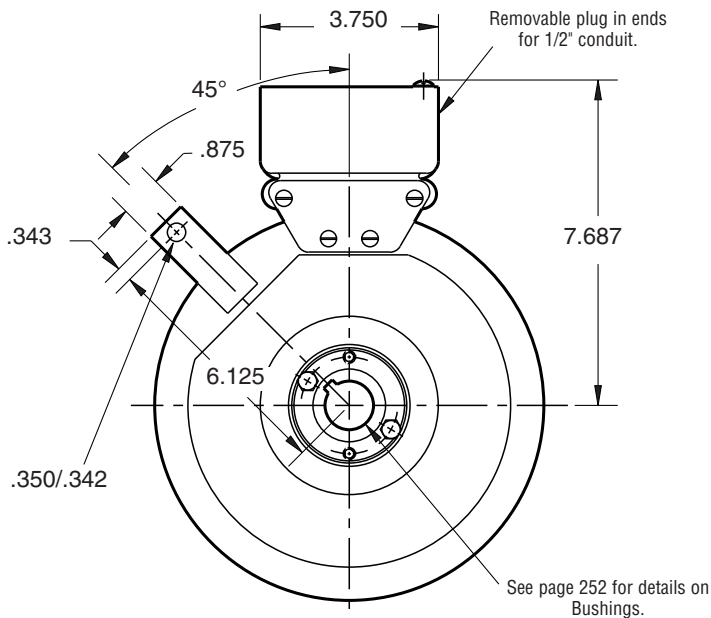

**FIELD VIEW**

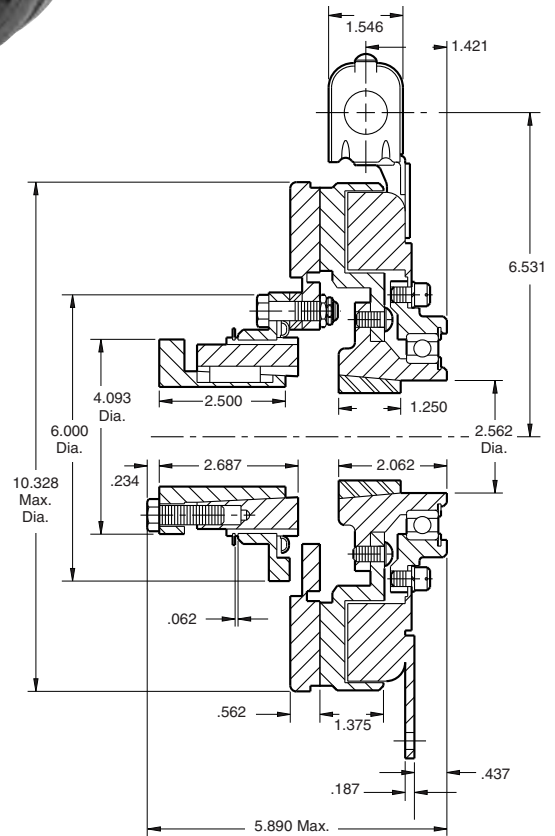

Armature Shaft	.750 – 2.687
Rotor Shaft	.500 – 2.000
Static Torque	240 lb. ft.
Maximum Speed	2,500 rpm
Standard Voltage	D.C. 6, 24, 90

### Customer Shall Maintain:

1. Armature mounting shaft concentric with field and rotor mounting shaft within .006 T.I.R.
2. Angular alignment of shafts within 1/2 degree.

All dimensions are nominal unless otherwise noted.

Information on inertia and weights begins on page 239. Coil data is on pages 250 and 251.



Drawing I-25598

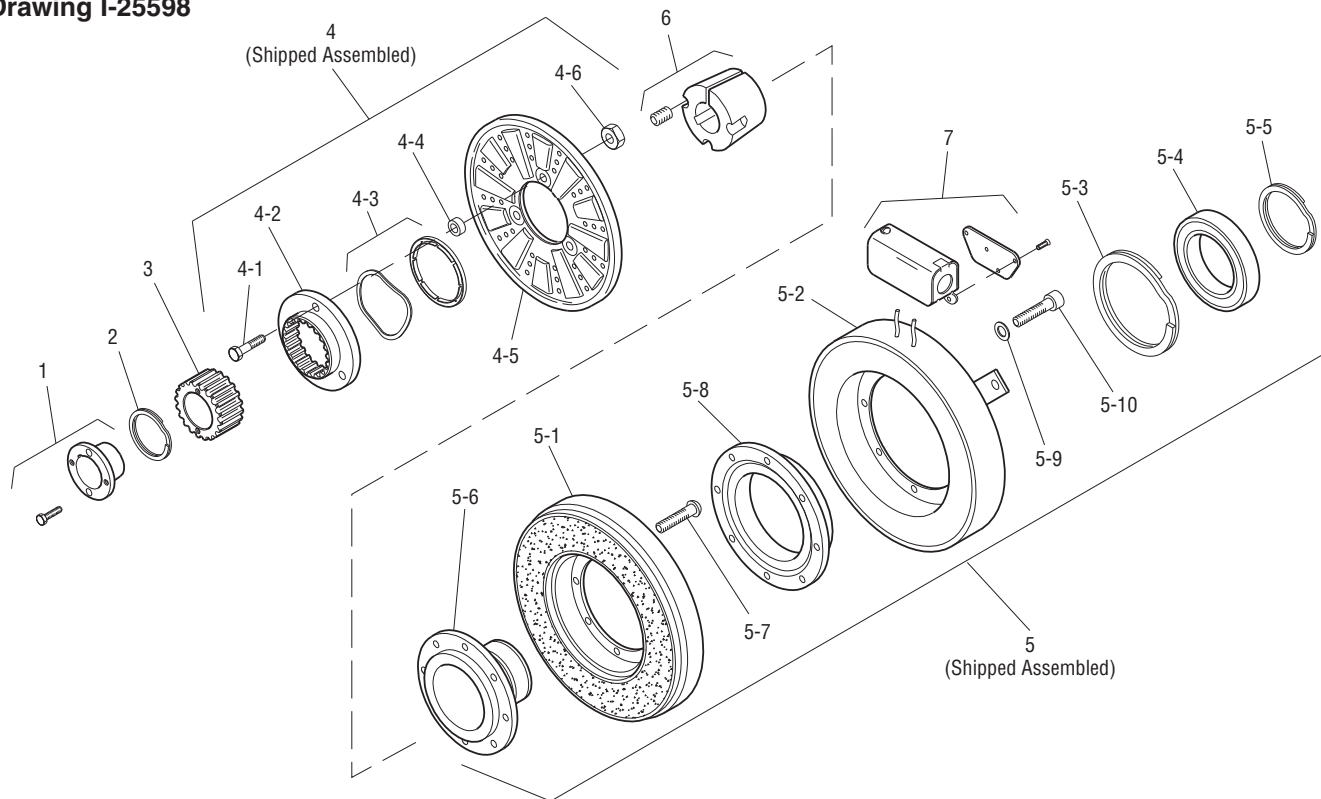

Item	Description	Part Number	Qty.
1	Bushing*		1
	3/4" to 2-11/16" Bore	180-0026 to 180-0057	
2	Retainer Ring	748-0007	1
3	Splined Hub	540-0062	1
4	Armature & Splined Adapter	5202-111-001	1
4-1	Capscrew	797-0341	3
4-2	Splined Adapter	104-0009	1
4-3	Autogap Accessory	5322-101-004	1
4-4	Spacer	748-0333	3
4-5	Armature	5322-111-036	1
4-6	Locknut	661-0004	3
5	Field & Rotor Assembly		1
	6 Volt	5202-452-012	
	24 Volt	5202-452-014	
	90 Volt	5202-452-015	
5-1	Rotor		1
	Standard Friction Material	5202-751-003	
	†Optional LK Facing	5202-751-007	
5-2	Field & Bearing Assembly		1
	6 Volt	5202-451-040	
	24 Volt	5202-451-042	
	90 Volt	5202-451-043	
5-3	Retainer Ring	748-0116	1
5-4	Ball Bearing	166-1046	1

Item	Description	Part Number	Qty.
5-5	Retainer Ring	748-0582	1
5-6	Rotor Hub	540-1300	1
5-7	Buttonhead Capscrew	797-1261	6
5-8	Ring Adapter	748-1047	1
5-9	Lockwasher	950-0359	6
5-10	Socket Head Capscrew	797-0422	6
6	Bushing*		1
	1/2" to 2" Bore	180-0155 to 180-0179	
7	Conduit Box	5200-101-012	1

### How to Order:

1. Specify Bore Size for Items 1 and 6.
2. Specify Voltage for Item 5.
3. See Controls Section.

### Example:

SFC-1000 Clutch Coupling per I-25598 - 90 Volt, 1" Bore

These units, when used in conjunction with the correct Warner Electric conduit box, meet the standards of UL508 and are listed under guide card #NMTR, file #59164. These units are CSA certified under file #LR11543.

\*See page 252 for specific part numbers.

Refer to Service Manual P-207.

†Optional LK facing available. For more information, see page 232.

# Clutch Coupling

## SFC-1225 Flange Mounted

See page 252 for details on bushings.

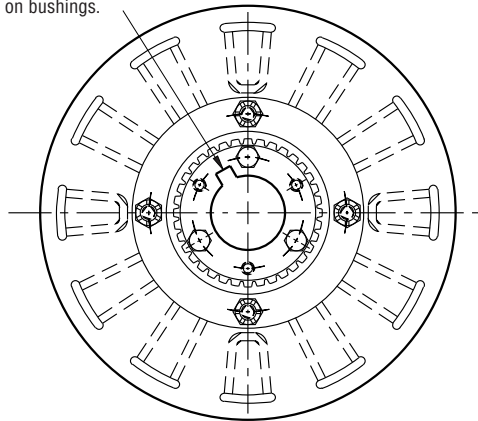

**ARMATURE VIEW**

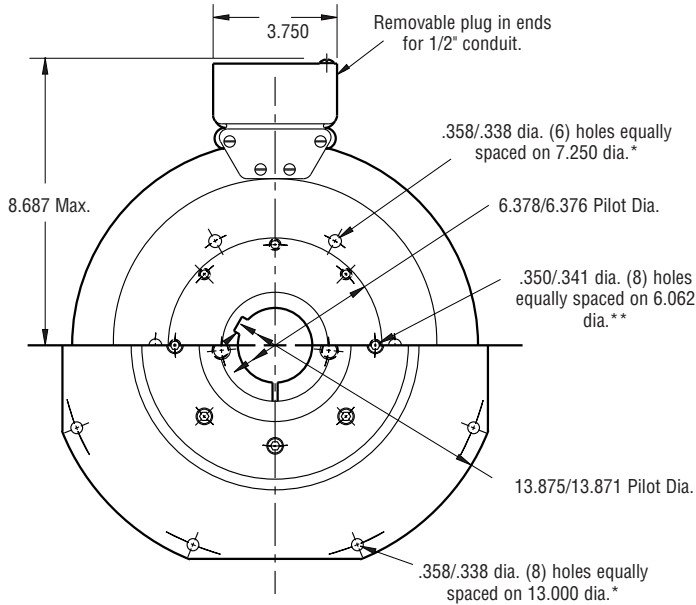

**FIELD VIEW  
(Inside & Outside Mounted)**

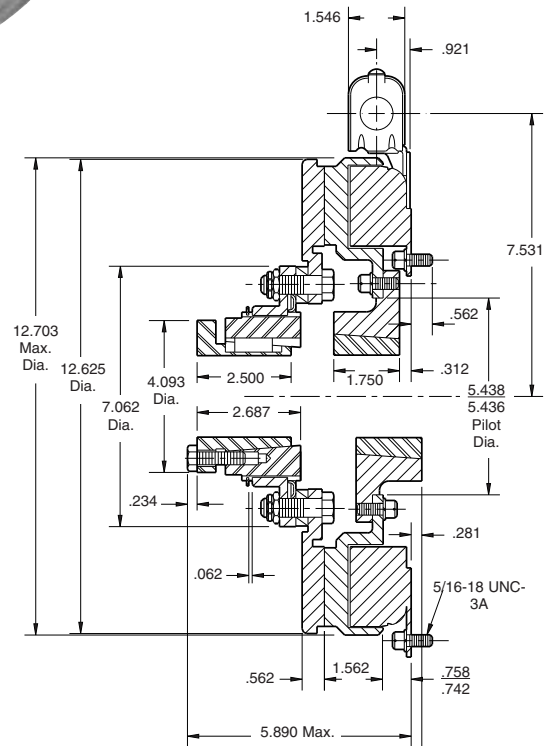

\* Mounting holes are within .010 of true position relative to pilot diameter.

\*\* Mounting holes are within .008 of true position relative to pilot diameter.

### Customer Shall Maintain:

1. Concentricity of field mounting pilot diameter with rotor mounting shaft within .006 T.I.R.
2. Squareness of field mounting face with rotor mounting shaft within .006 T.I.R. measured at field mounting bolt circle.
3. Rotor mounting shaft concentric with armature mounting shaft within .006 T.I.R.
4. Angular alignment of shafts within 1/2 degree.

### When Hub is Furnished by Customer:

Rotor mounting pilot diameter must be concentric with rotor mounting shaft within .006 T.I.R.

Armature Shaft	.750 – 2.687
Rotor Shaft	.500 – 2.500
Static Torque	465 lb. ft.
Maximum Speed	3,000 rpm
Standard Voltage	D.C. 6, 24, 90

All dimensions are nominal unless otherwise noted.

Information on inertia and weights begins on page 239. Coil data is on pages 250 and 251.



Drawing I-25604

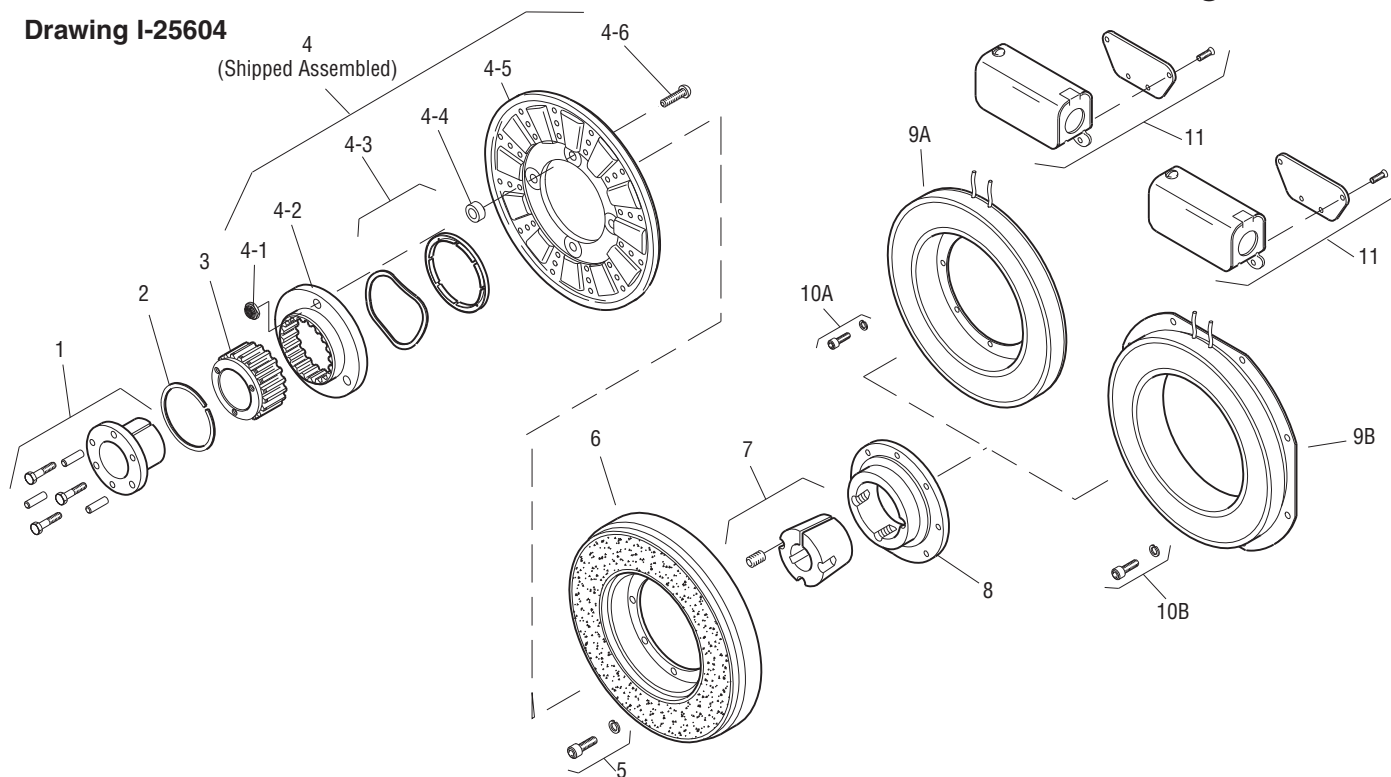

Item	Description	Part Number	Qty.
1	Bushing*		1
	3/4" to 2-11/16" Bore	180-0026 to 180-0057	
2	Retainer Ring	748-0005	1
3	Splined Hub	540-0064	1
4	Armature & Splined Adapter	5203-111-001	1
4-1	Locknut	661-0004	4
4-2	Splined Adapter	104-0010	1
4-3	Autogap Accessory	5323-101-002	1
4-4	Spacer	266-0004	4
4-5	Armature	5323-111-034	1
4-6	Screw	797-0356	4
5	Mounting Accessory	5321-101-002	2
6	Rotor		1
	Standard Friction Material	5203-751-001	
	†Optional LK Facing	5203-751-004	
7	Bushing*		1
	1/2" to 2-1/2" Bore	180-0185 to 180-0217	
8	Rotor Hub	540-0318	1
9A	Field - Inside Mounted		1
	6 Volt	5203-451-002	
	24 Volt	5203-451-006	
	90 Volt	5203-451-005	
9B	Field - Outside Mounted		1
	6 Volt	5203-451-010	
	24 Volt	5203-451-013	
	90 Volt	5203-451-011	

Item	Description	Part Number	Qty.
10A	Mounting Accessory - I.M.	5321-101-001	1
10B	Mounting Accessory - O.M.	5321-101-002	2
11	Conduit Box	5200-101-012	1

### How to Order:

1. Specify Bore Size for Item 1.
2. Specify Bore Size for Item 7.
3. Specify Voltage for Item 9A or 9B.
4. Specify Inside or Outside Mounted for Item 5.
5. Specify Inside Mounted for Items 9A and 10A or Outside Mounted for Items 9B and 10B.
6. See Controls Section.

### Example:

SFC-1225 Clutch Coupling per I-25604 - 90 Volt, Inside Mounted, 1-1/2" Bore (Item 1), 1-3/4" Bore (Item 7).

These units, when used in conjunction with the correct Warner Electric conduit box, meet the standards of UL508 and are listed under guide card #NMTR, file #59164. These units are CSA certified under file #LR11543.

\*See page 252 for specific part numbers.

Refer to Service Manual P-207.

†Optional LK facing available. For more information, see page 232.

# Clutch Coupling

## SFC-1225 Bearing Mounted



See page 252 for details on bushings.

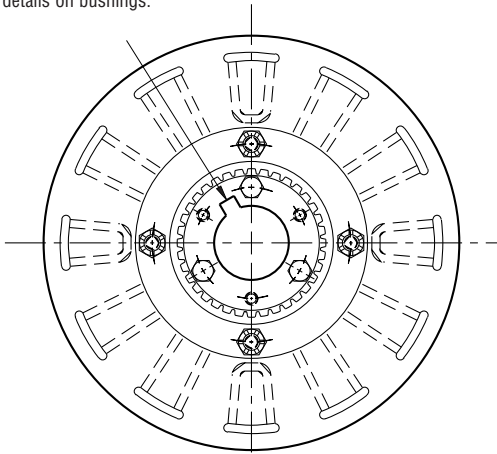

**ARMATURE VIEW**

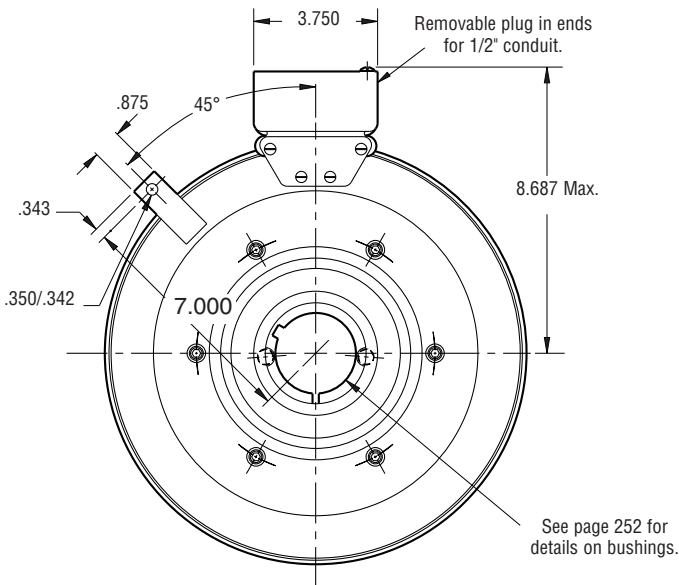

**FIELD VIEW**

See page 252 for details on bushings.

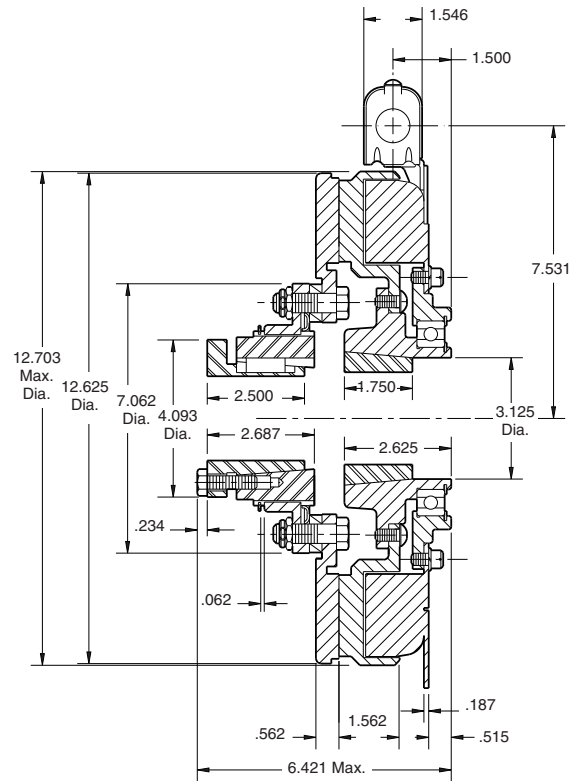

Armature Shaft	.750 – 2.687
Rotor Shaft	.500 – 2.500
Static Torque	465 lb. ft.
Maximum Speed	2,200 rpm
Standard Voltage	D.C. 6, 24, 90

### Customer Shall Maintain:

1. Armature mounting shaft concentric with field and rotor mounting shaft within .006 T.I.R.
2. Angular alignment of shafts within 1/2 degree.

All dimensions are nominal unless otherwise noted.

Information on inertia and weights begins on page 239. Coil data is on pages 250 and 251.



Drawing I-25623

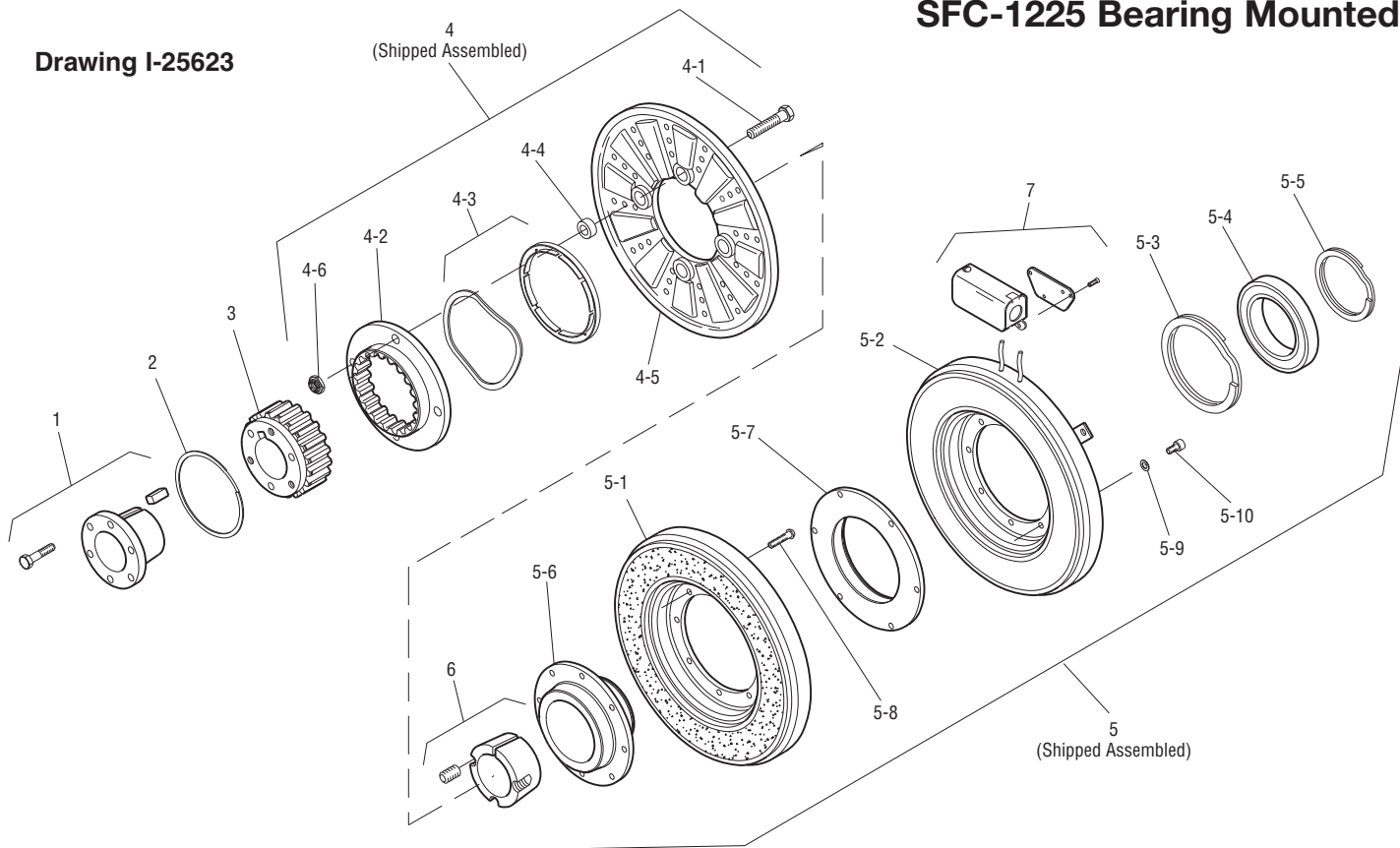

Item	Description	Part Number	Qty.
1	Bushing*		1
	3/4" to 2-11/16" Bore	180-0026 to 180-0057	
2	Retainer Ring	748-0005	1
3	Splined Hub	540-0064	1
4	Armature & Splined Adapter	5203-111-001	1
4-1	Capscrew	797-0356	4
4-2	Splined Adapter	104-0010	1
4-3	Autogap Accessory	5323-101-002	1
4-4	Spacer	266-0004	4
4-5	Armature	5323-111-034	1
4-6	Locknut	661-0005	4
5	Field & Rotor Assembly		1
	6 Volt	5203-452-009	
	24 Volt	5203-452-011	
	90 Volt	5203-452-012	
5-1	Rotor		1
	Standard Friction Material	5203-751-001	
	†Optional LK Facing	5203-751-004	
5-2	Field		1
	6 Volt	5203-451-034	
	24 Volt	5203-451-036	
	90 Volt	5203-451-037	
5-3	Retainer Ring	748-0119	1
5-4	Ball Bearing	166-1047	1

Item	Description	Part Number	Qty.
5-5	Retainer Ring	748-0011	1
5-6	Rotor Hub	540-1304	1
5-7	Ring Adapter	748-0591	1
5-8	Buttonhead Capscrew	797-1261	6
5-9	Lockwasher	950-0359	6
5-10	Sockethead Capscrew	797-0424	6
6	Bushing*		1
	1/2" to 2-1/2" Bore	180-0185 to 180-0217	
7	Conduit Box	5200-101-012	1

### How to Order:

1. Specify Bore Size for Item 1.
2. Specify Bore Size for Item 6.
3. Specify Voltage for Item 5.
4. See Controls Section.

### Example:

SFC-1225 Clutch Coupling per I-25623 - 90 Volt, 1" Bore

These units, when used in conjunction with the correct Warner Electric conduit box, meet the standards of UL508 and are listed under guide card #NMTR, file #59164. These units are CSA certified under file #LR11543.

\*See page 252 for specific part numbers.

Refer to Service Manual P-207.

†Optional LK facing available. For more information, see page 232.

# Clutch Coupling

## SFC-1525 Flange Mounted

See page 252 for details on bushings.

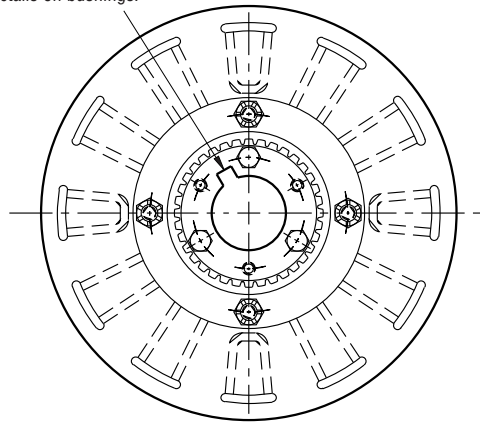

**ARMATURE VIEW**

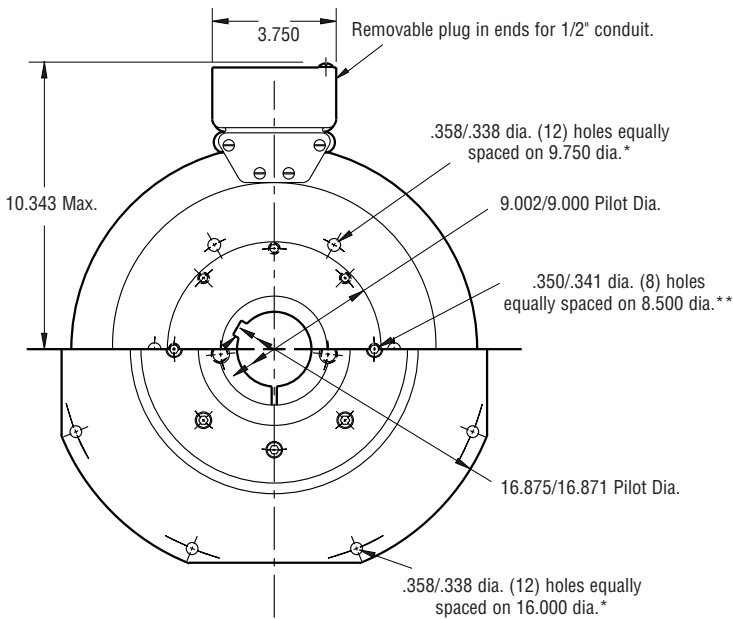

**FIELD VIEW  
(Inside & Outside Mounted)**

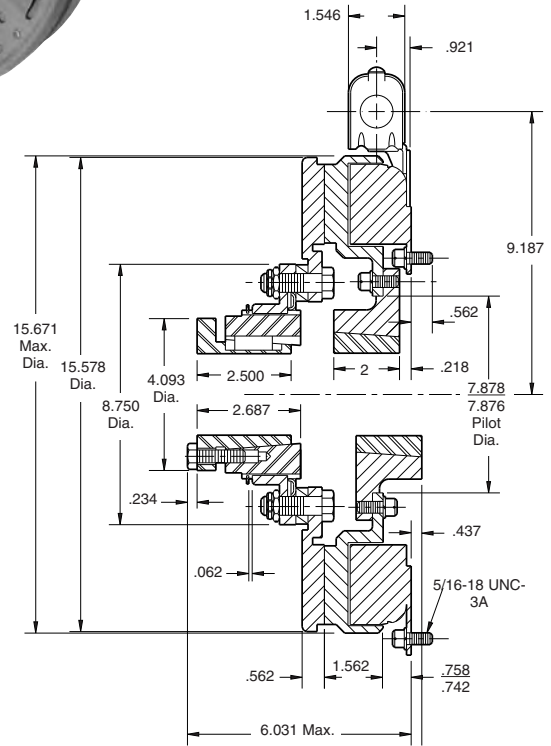

\* Mounting holes are within .010 of true position relative to pilot diameter.

\*\* Mounting holes are within .008 of true position relative to pilot diameter.

### Customer Shall Maintain:

1. Concentricity of field mounting pilot diameter with rotor mounting shaft within .006 T.I.R.
2. Squareness of field mounting face with rotor mounting shaft within .006 T.I.R. measured at field mounting bolt circle.
3. Rotor mounting shaft concentric with armature mounting shaft within .006 T.I.R.
4. Angular alignment of shafts within 1/2 degree.

### When Hub is Furnished by Customer:

Rotor mounting pilot diameter must be concentric with rotor mounting shaft within .006 T.I.R.

Armature Shaft	.750 – 2.687
Rotor Shaft	.937 – 3.000
Static Torque	700 lb. ft.
Maximum Speed	2,000 rpm
Standard Voltage	D.C. 6, 24, 90

All dimensions are nominal unless otherwise noted.

Information on inertia and weights begins on page 239. Coil data is on pages 250 and 251.





# Clutch Coupling

## SFC-1525 Flange Mounted

Drawing I-25630

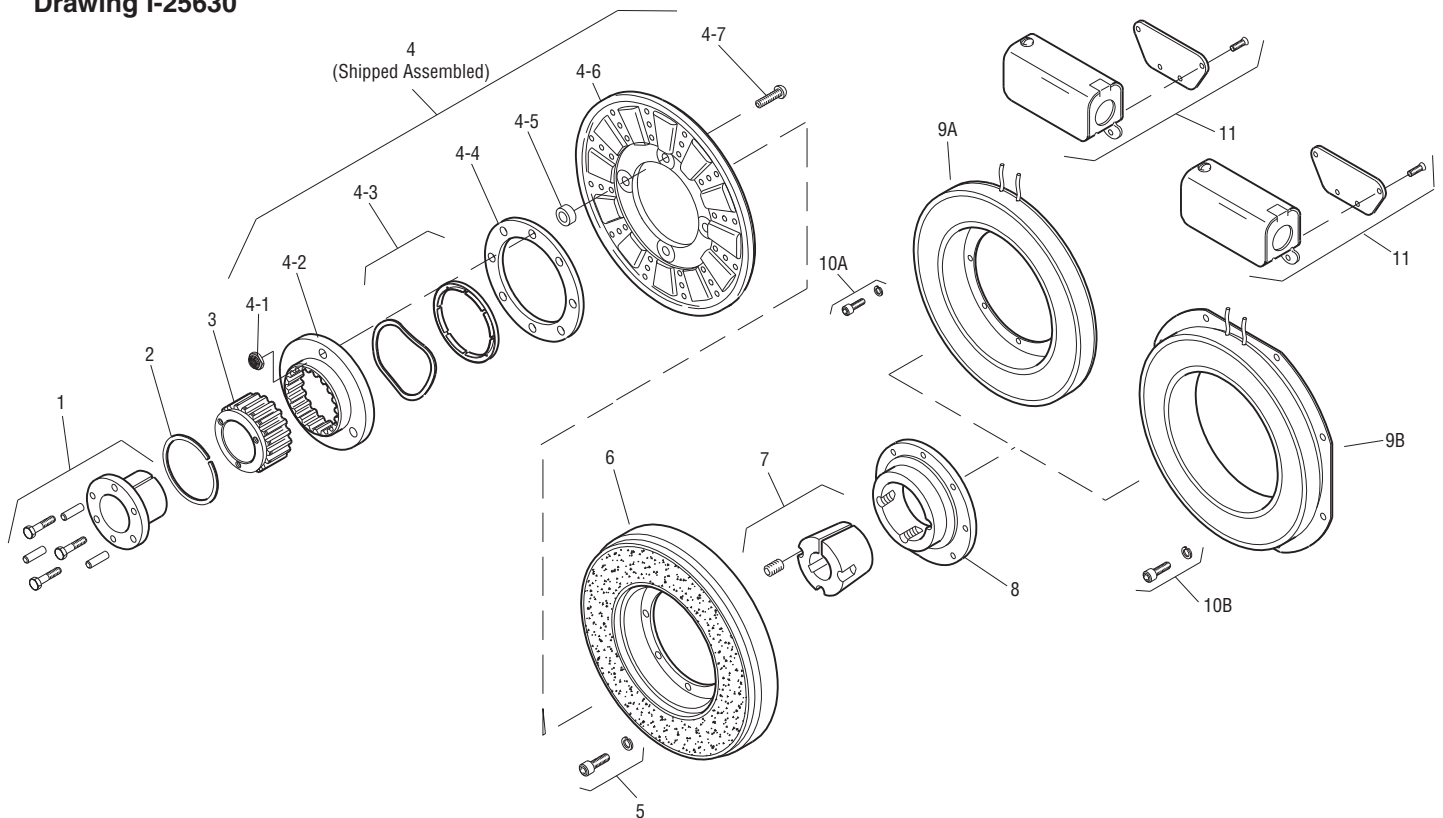

Item	Description	Part Number	Qty.
1	Bushing*		1
	3/4" to 2-11/16" Bore	180-0026 to 180-0057	
2	Retainer Ring	748-0005	1
3	Splined Hub	540-0064	1
4	Armature & Splined Adapter	5204-111-004	1
4-1	Locknut	661-0004	8
4-2	Splined Adapter	104-0011	1
4-3	Autogap Accessory	5323-101-002	1
4-4	Retainer Plate	686-0003	1
4-5	Spacer	748-0333	8
4-6	Armature	5324-111-034	1
4-7	Screw	797-0342	8
5	Mounting Accessory	5321-101-002	2
6	Rotor		1
	Standard Friction Material	5204-751-002	
	†Optional LK Facing	5204-751-004	
7	Bushing*		1
	15/16" to 3" Bore	180-0223 to 180-0256	
8	Rotor Hub	540-0004	1
9A	Field - Inside Mounted		1
	6 Volt	5204-451-013	
	24 Volt	5204-451-015	
	90 Volt	5204-451-016	

Item	Description	Part Number	Qty.
9B	Field - Outside Mounted		1
	6 Volt	5204-451-055	
	24 Volt	5204-451-056	
	90 Volt	5204-451-057	
10A	Mounting Accessory - I.M.	5321-101-001	2
10B	Mounting Accessory - O.M.	5321-101-001	2
11	Conduit Box	5200-101-012	1

### How to Order:

1. Specify Bore Size for Item 1.
2. Specify Bore Size for Item 7.
3. Specify Voltage for Item 9A or 9B.
4. Specify Inside Mounted for Items 9A and 10A or Outside Mounted for Items 9B and 10B.
5. See Controls Section.

### Example:

SFC-1525 Clutch Coupling per I-25630 - 90 Volt, Inside Mounted, 1-1/2" Bore (Item 1), 1-3/4" Bore (Item 7).

These units, when used in conjunction with the correct Warner Electric conduit box, meet the standards of UL508 and are listed under guide card #NMTR, file #59164.

These units are CSA certified under file #LR11543.

\*See page 252 for specific part numbers.

Refer to Service Manual P-207.

†Optional LK facing available. For more information, see page 232.

# Clutch Coupling

## SFC-1525 Bearing Mounted



See page 252 for details on bushings.

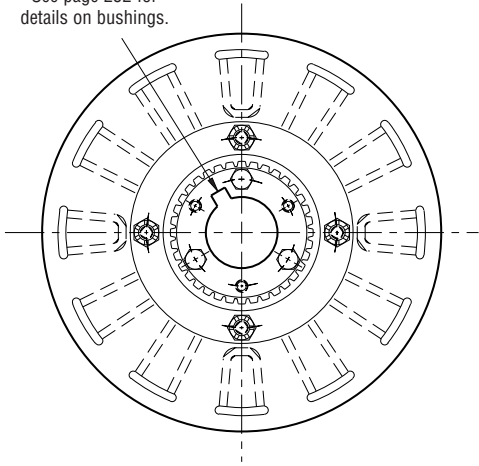

**ARMATURE VIEW**

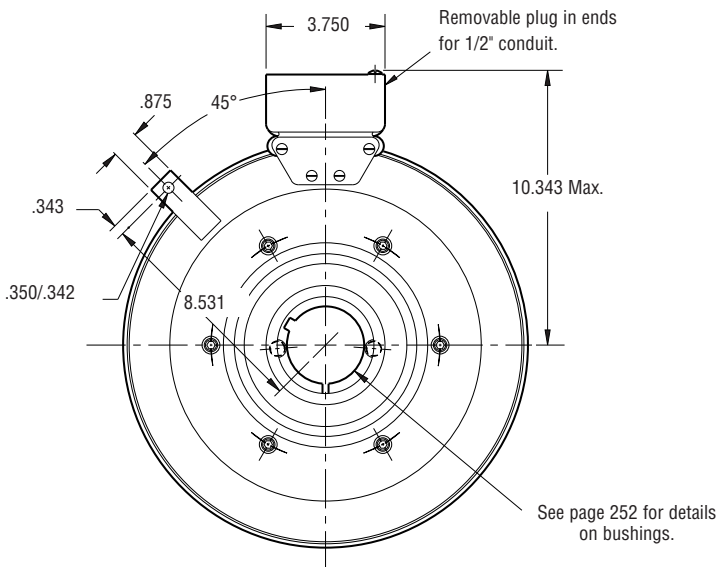

**FIELD VIEW**

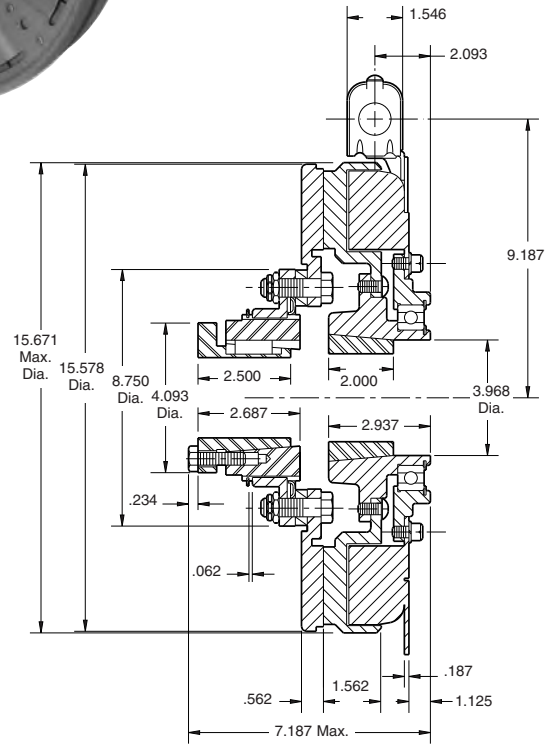

Armature Shaft	.750 – 2.687
Rotor Shaft	.937 – 3.000
Static Torque	700 lb. ft.
Maximum Speed	1,800 rpm
Standard Voltage	D.C. 6, 24, 90

All dimensions are nominal unless otherwise noted.

Information on inertia and weights begins on page 239. Coil data is on pages 250 and 251.

### Customer Shall Maintain:

1. Armature mounting shaft concentric with field and rotor mounting shaft within .006 T.I.R.
2. Angular alignment of shafts within 1/2 degree.



Drawing I-25641

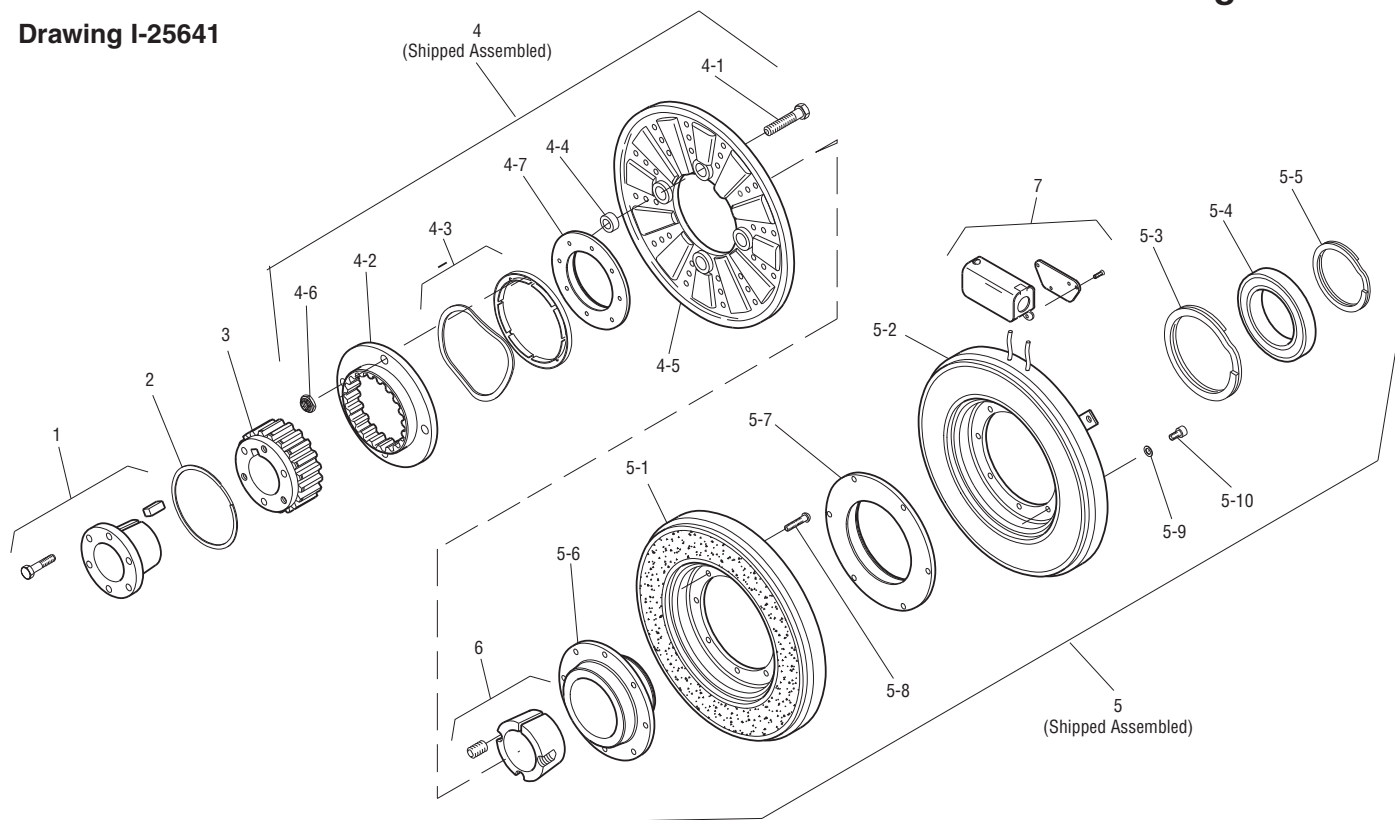

Item	Description	Part Number	Qty.
1	Bushing*		1
	3/4" to 2-11/16" Bore	180-0026 to 180-0057	
2	Retainer Ring	748-0005	1
3	Splined Hub	540-0064	1
4	Armature & Splined Adapter	5204-111-004	1
4-1	Capscrew	797-0342	8
4-2	Splined Adapter	104-0011	1
4-3	Autogap Accessory	5323-101-002	1
4-4	Spacer	748-0333	8
4-5	Armature	5324-111-034	1
4-6	Locknut	661-0004	8
4-7	Retainer Plate	681-0003	1
5	Field & Rotor Assembly		1
	6 Volt	5204-452-009	
	24 Volt	5204-452-011	
	90 Volt	5204-452-012	
5-1	Rotor		1
	Standard Friction Material	5204-751-002	
	†Optional LK Facing	5204-751-004	
5-2	Field		1
	6 Volt	5204-451-084	
	24 Volt	5204-451-086	
	90 Volt	5204-451-087	
5-3	Retainer Ring	748-0114	1
5-4	Ball Bearing	166-0163	1

Item	Description	Part Number	Qty.
5-5	Retainer Ring	748-0583	1
5-6	Rotor Hub	540-1306	1
5-7	Ring Adapter	748-1048	1
5-8	Buttonhead Capscrew	797-1261	8
5-9	Lockwasher	950-0359	6
5-10	Sockethead Capscrew	797-0424	6
6	Bushing*		1
	15/16" to 3" Bore	180-0223 to 180-0256	
7	Conduit Box	5200-101-012	1

### How to Order:

1. Specify Bore Size for Item 1.
2. Specify Bore Size for Item 6.
3. Specify Voltage for Item 5.
4. See Controls Section.

### Example:

SFC-1525 Clutch Coupling per I-25641 - 90 Volt, 1" Bore

These units, when used in conjunction with the correct Warner Electric conduit box, meet the standards of UL508 and are listed under guide card #NMTR, file #59164. These units are CSA certified under file #LR11543.

\*See page 252 for specific part numbers.

Refer to Service Manual P-207.

†Optional LK facing available. For more information, see page 232.

# Clutch Coupling, Hi-Torque

## SFC-1525 H.T. Flange Mounted

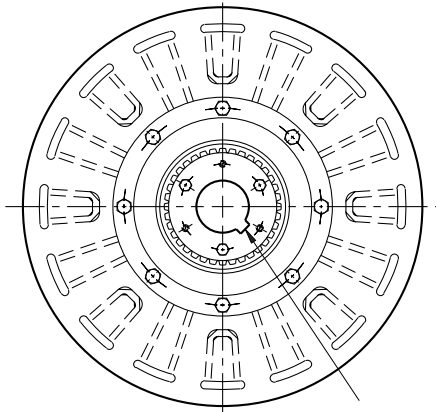

See page 252 for details on bushings.

### ARMATURE VIEW

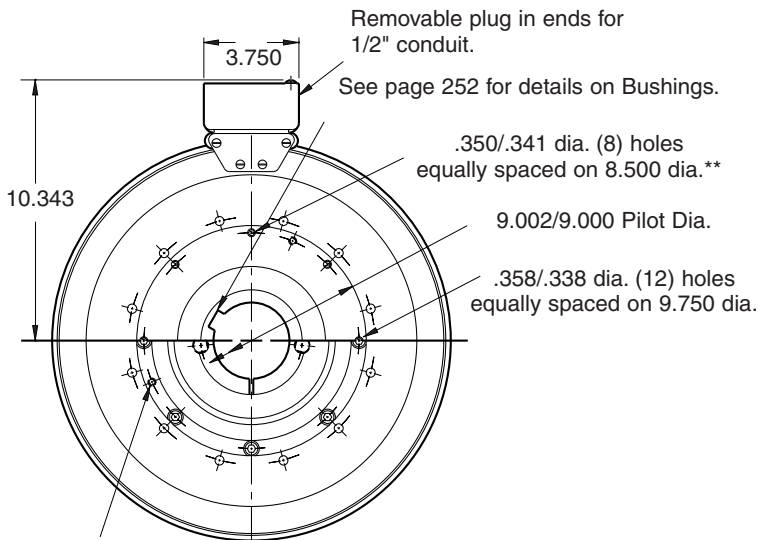

### FIELD VIEW

#### Customer Shall Maintain:

1. Concentricity of field mounting pilot diameter with rotor mounting shaft within .006 T.I.R.
2. Squareness of field mounting face with rotor mounting shaft within .006 T.I.R. measured at field mounting bolt circle.
3. Rotor mounting shaft concentric with armature mounting shaft within .006 T.I.R.
4. Angular alignment of shafts within 1/2 degree.

#### When Hub is Furnished by Customer:

Rotor mounting pilot diameter must be concentric with rotor mounting shaft within .006 T.I.R.

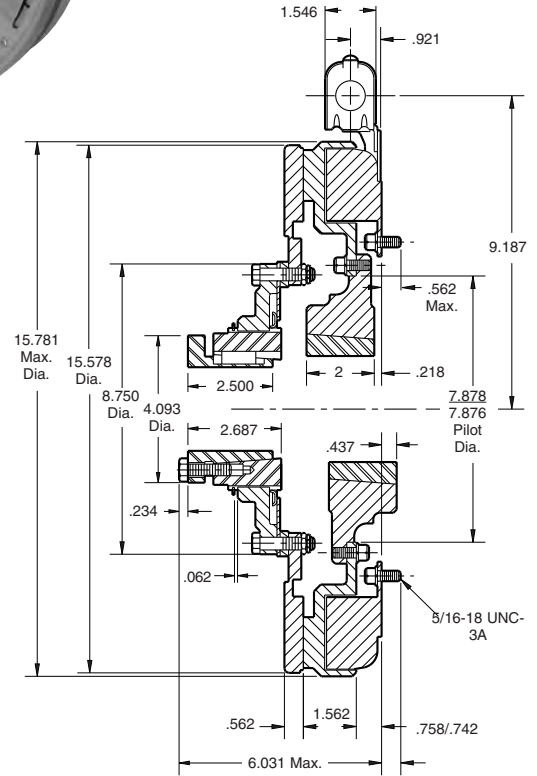

\*Mounting holes are within .010 of true position relative to pilot diameter.

\*\*Mounting holes are within .008 of true position relative to pilot diameter.

Armature Shaft	.750 – 2.687
Rotor Shaft	.937 – 3.000
Static Torque	1,350 lb.ft.
Maximum Speed	2,000 rpm
Standard Voltage	D.C. 6, 90

All dimensions are nominal unless otherwise noted.

Information on inertia and weights begins on page 239. Coil data is on pages 250 and 251.



# Clutch Coupling, Hi-Torque

## SFC-1525 H.T Flange Mounted.

Drawing I-25631

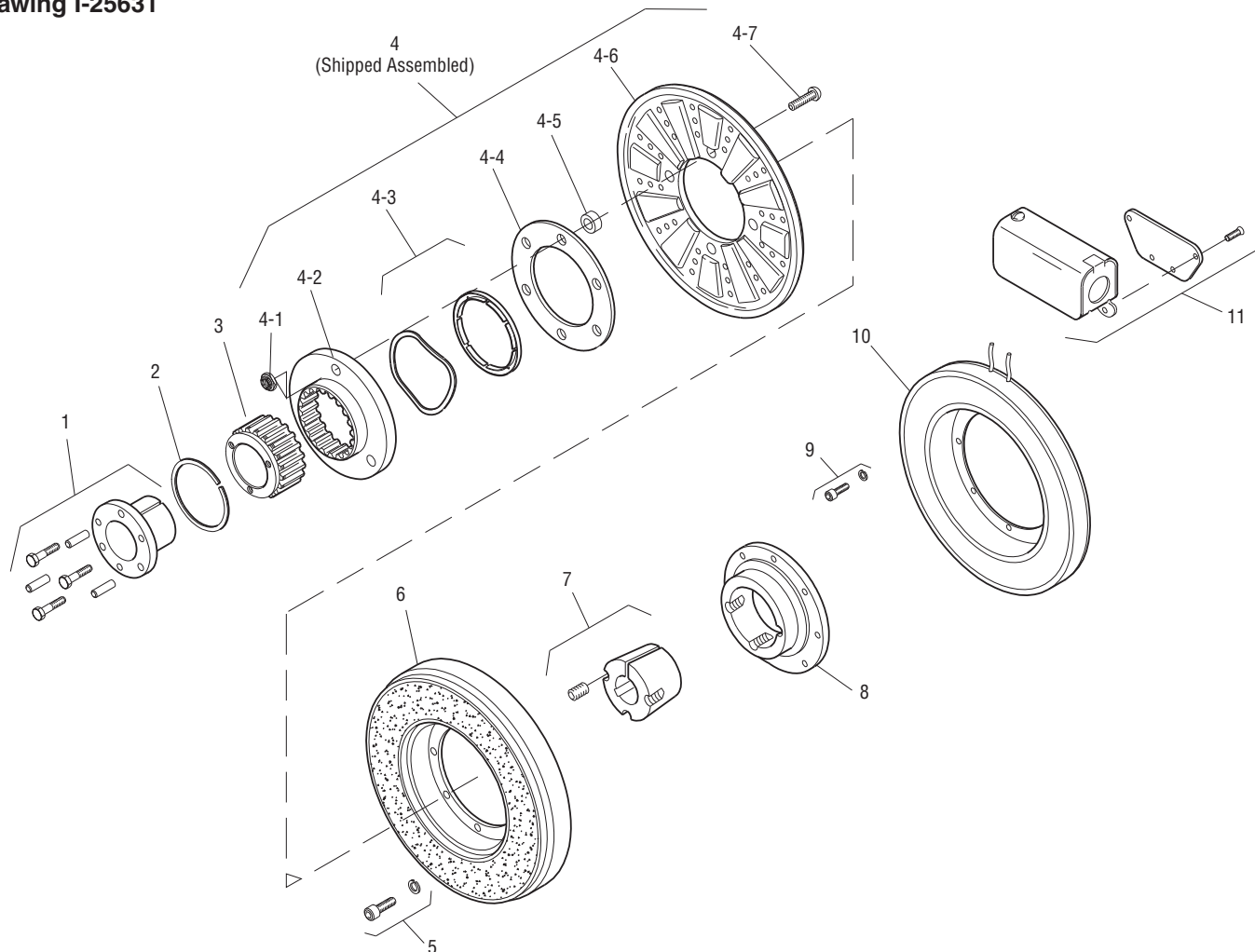

Item	Description	Part Number	Qty.
1	Bushing*		1
	3/4" to 2-11/16" Bore	180-0026 to 180-0057	
2	Retainer Ring	748-0005	1
3	Splined Hub	540-0064	1
4	Armature & Splined Adapter	5204-111-004	1
4-1	Locknut	661-0004	8
4-2	Splined Adapter	104-0011	1
4-3	Autogap Accessory	5323-101-002	1
4-4	Retainer Plate	686-0003	1
4-5	Spacer	748-0333	8
4-6	Armature	5324-111-034	1
4-7	Screw	797-0342	8
5	Mounting Accessory	5321-101-002	2
6	Rotor	5204-751-001	1
7	Bushing*		1
	15/16" to 3" Bore	180-0223 to 180-0256	
8	Rotor Hub	540-0004	1
9	Field - Inside Mounted		1
	90 Volt	5204-451-006	

Item	Description	Part Number	Qty.
10	Mounting Accessory - I.M.	5321-101-001	2
11	Conduit Box	5200-101-012	1

### How to Order:

1. Specify Bore Size for Item 1.
2. Specify Bore Size for Item 7.
3. See Controls Section.

### Example:

SFC-1525 Clutch Coupling, Hi-Torque,  
per I-25631 - 90 Volt

2" Bore (Item 1), 2-1/2" Bore (Item 7)

These units, when used in conjunction with the correct Warner Electric conduit box, meet the standards of UL508 and are listed under guide card #NMTR, file #59164. These units are CSA certified under file #LR11543.

\*See page 252 for specific part numbers.

Refer to Service Manual P-207.

# Clutch Coupling, Hi-Torque

## SFC-1525 H.T. Bearing Mounted

See page 252 for details on Bushings.

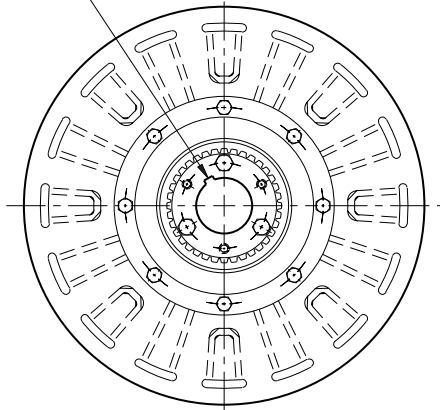

**ARMATURE VIEW**

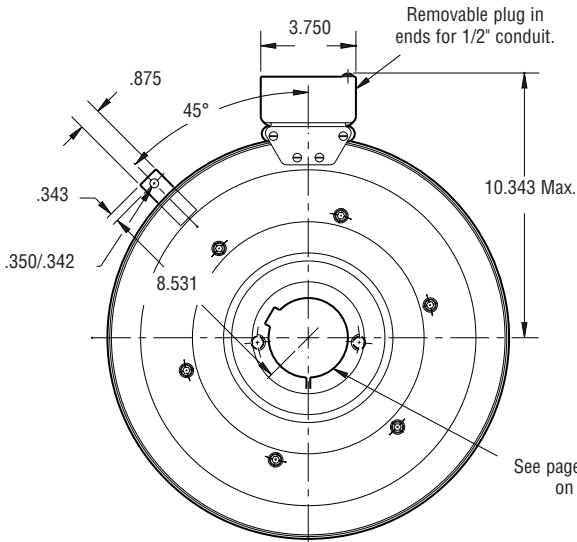

**FIELD VIEW**

See page 252 for details on Bushings.

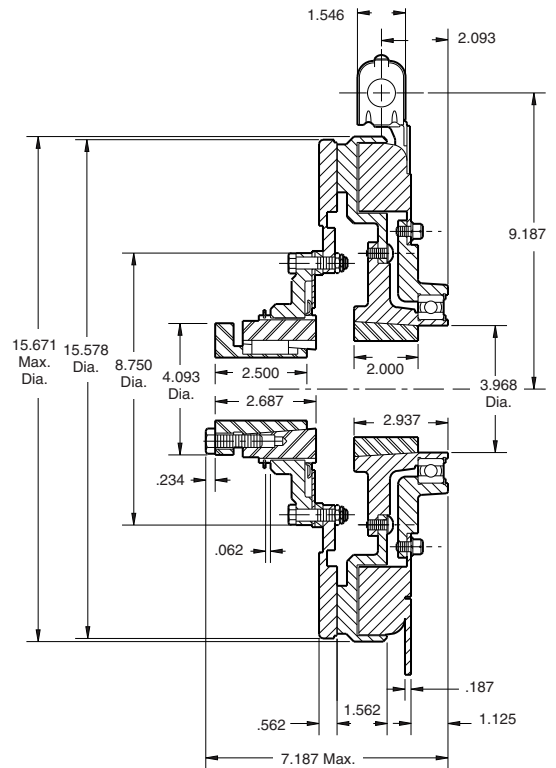

### Customer Shall Maintain:

1. Armature mounting shaft concentric with field and rotor mounting shaft within .006 T.I.R.
2. Angular alignment of shafts within 1/2 degree.

Armature Shaft	.750 – 2.687
Rotor Shaft	.937 – 3.000
Static Torque	1,350 lb.ft.
Maximum Speed	1,800 rpm
Standard Voltage	D.C. 90

All dimensions are nominal unless otherwise noted.

Information on inertia and weights begins on page 239. Coil data is on pages 250 and 251.



# Clutch Coupling, Hi-Torque

## SFC-1525 H.T. Bearing Mounted

Drawing I-25644

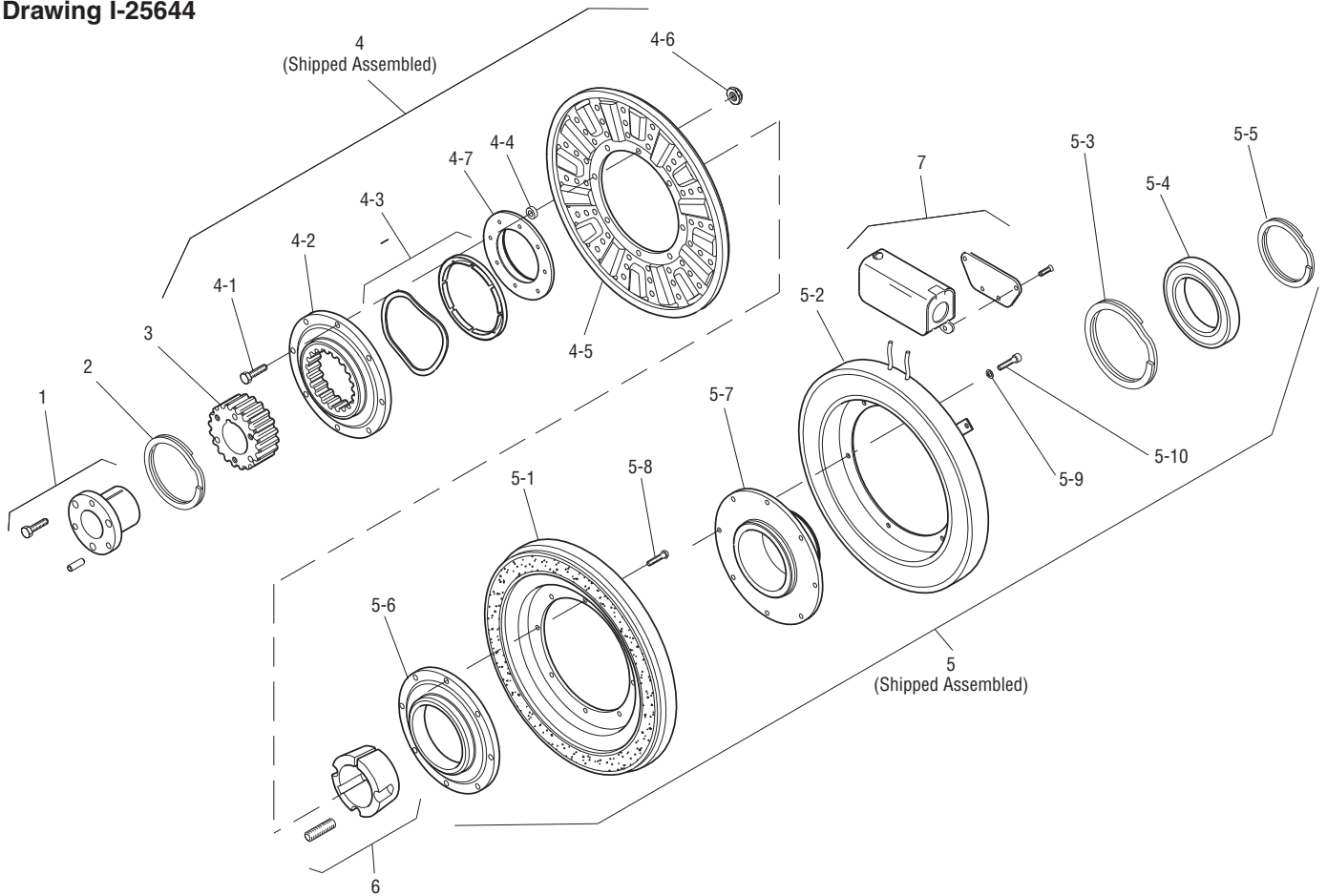

Item	Description	Part Number	Qty.
1	Bushing*		1
	3/4" to 2-11/16" Bore	180-0026 to 180-0057	
2	Retainer Ring	748-0005	1
3	Splined Hub	540-0064	1
4	Armature & Splined Adapter	5204-111-004	1
4-1	Capscrew	797-0342	8
4-2	Splined Adapter	104-0011	1
4-3	Autogap Accessory	5323-101-002	1
4-4	Spacer	748-0333	8
4-5	Armature	5324-111-034	1
4-6	Locknut	661-0004	8
4-7	Retainer Plate	681-0003	1
5	Field & Rotor Assembly		1
	90 Volt	5204-452-015	
5-1	Rotor	5204-751-001	1
5-2	Field		1
	90 Volt	5204-451-090	
5-3	Retainer Ring	748-0114	1
5-4	Ball Bearing	166-0163	1
5-5	Retainer Ring	748-0583	1
5-6	Rotor Hub	540-1306	1
5-7	Ring Adapter	748-1048	1

Item	Description	Part Number	Qty.
5-8	Buttonhead Capscrew	797-1261	8
5-9	Lockwasher	950-0359	6
5-10	Sockethead Capscrew	797-0424	6
6	Bushing*		1
	5/16" to 3" Bore	180-0223 to 180-0256	
7	Conduit Box	5200-101-012	1

### How to Order:

1. Specify Bore Size for Item 1.
2. Specify Bore Size for Item 6.
3. Specify Voltage for Item 5.
4. See Controls Section.

### Example:

SFC-1525 Clutch Coupling Hi-Torque per I-25644 - 90 Volt, 1" Bore

These units, when used in conjunction with the correct Warner Electric conduit box, meet the standards of UL508 and are listed under guide card #NMTR, file #59164. These units are CSA certified under file #LR11543.

\*See page 252 for specific part numbers.

Refer to Service Manual P-207.

# Clutch Coupling

## PCC-500 Normal Duty



See page 252 for details on Bushings.

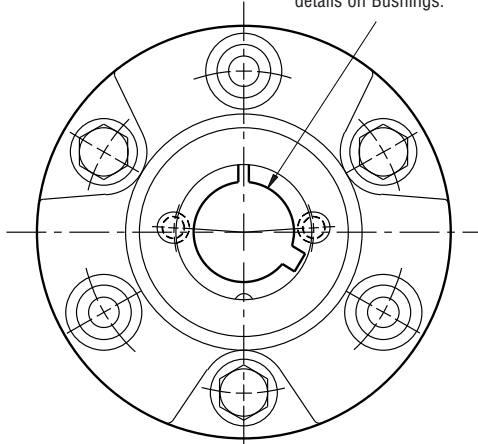

**HUB VIEW**

1/2-14 NPSM Am. std. straight pipe tap.

See page 252 for details on Bushings.

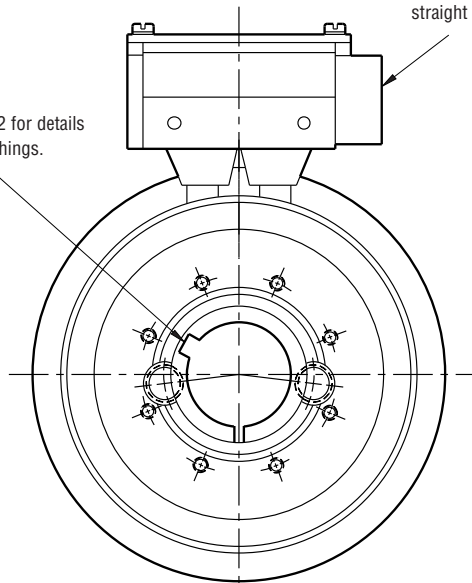

**COLLECTOR RING VIEW**

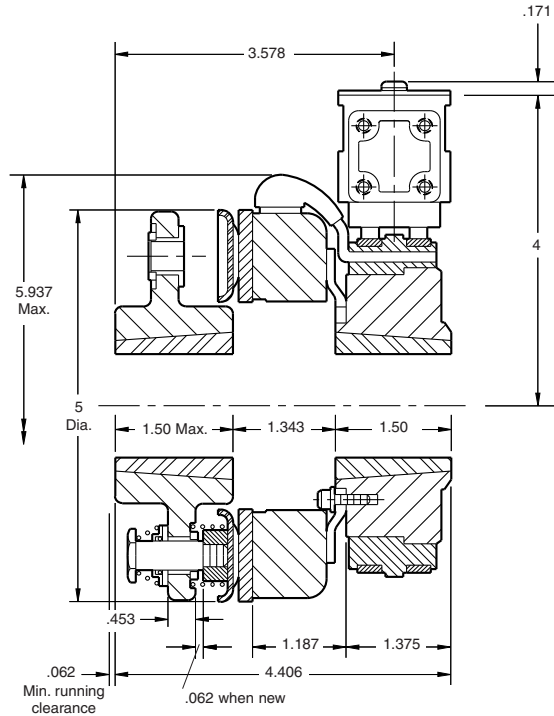

Armature Shaft	.500 – 1.250
Magnet Shaft	.500 – 1.250
Static Torque	40 lb.ft.
Maximum Speed	5,400 rpm
Standard Voltage	D.C. 6, 24, 90

All dimensions are nominal unless otherwise noted.

Information on inertia and weights begins on page 239. Coil data is on pages 250 and 251.

### Customer Shall Maintain:

1. Armature mounting shaft concentric with magnet mounting shaft within .006 T.I.R.





Drawing I-25542

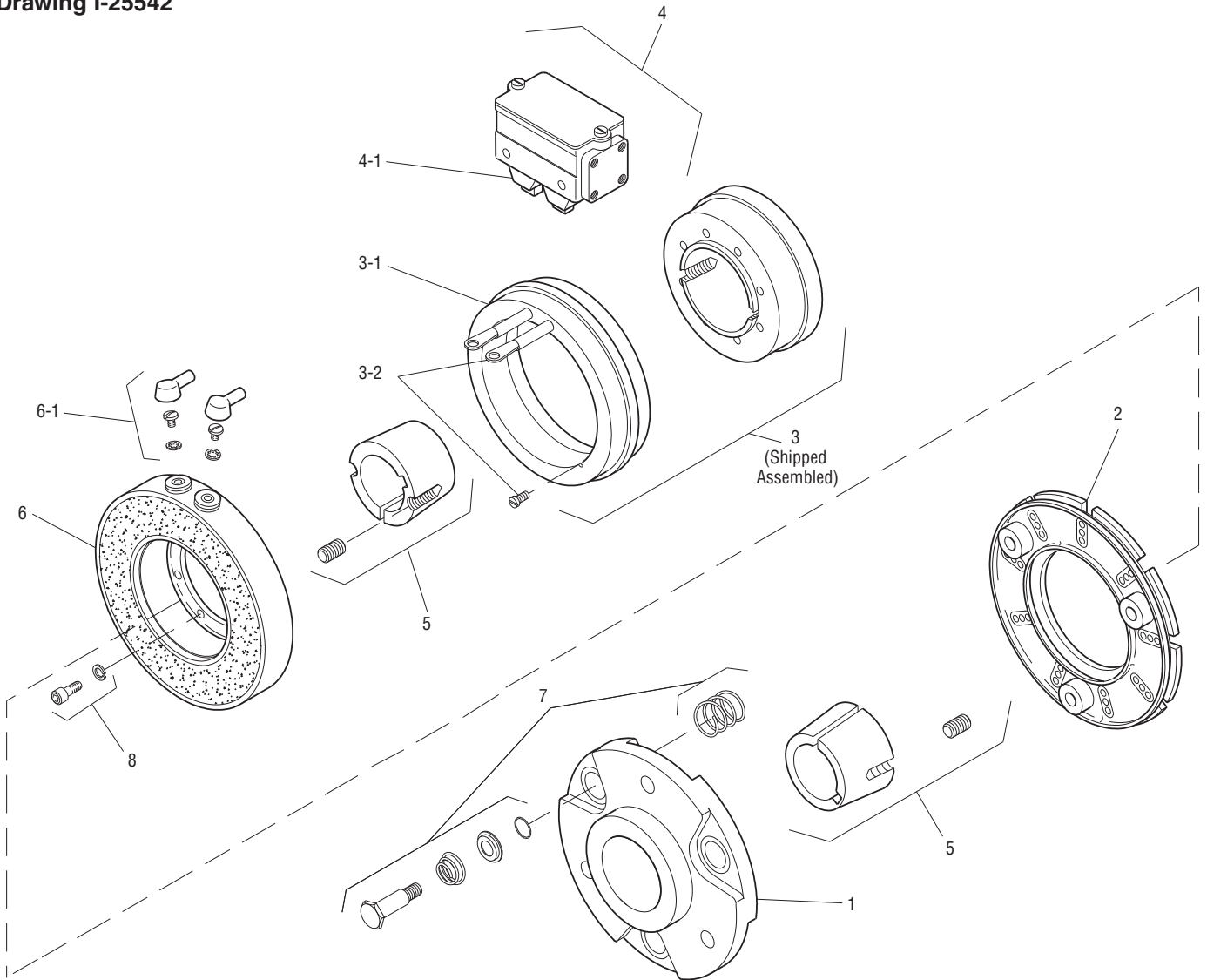

Item	Description	Part Number	Qty.
1	Armature Hub	5300-541-004	1
2	Armature	5300-111-002	1
3	Magnet Hub	5300-541-001	1
3-1	Collector Ring	5300-749-001	1
3-2	Collector Ring Mounting Accessory	5300-101-002	1
4	Brushholder	5300-178-001	1
4-1	Brush	176-0001	4
5	Bushing*		2
	1/2" to 1-1/4" Bore	180-0116 to 180-0128	
6	Magnet		
	6 Volt	5300-631-002	
	24 Volt	5300-631-003	
	90 Volt	5300-631-005	
6-1	Terminal Accessory	5311-101-001	1
7	Autogap Accessory	5200-101-009	3

Item	Description	Part Number	Qty.
8	Mounting Accessory	5102-101-001	2

### How to Order:

1. Specify Bore Size for Item 5 (two shafts).
2. Specify Voltage for Item 7.
3. See Controls Section.

### Example:

PCC-500 Clutch Coupling per I-25542 - 90 Volt  
3/4" Bore

These units meet standards set forth in UL508 and are listed under guide card #NMTR2, file #59164.

These units are CSA certified under file #LR11543

\*See page 252 for specific part numbers.

Refer to Service Manual P-203.

# Clutch Coupling

## PCC-500 Heavy Duty



For Bore & Keyway sizes see chart below.

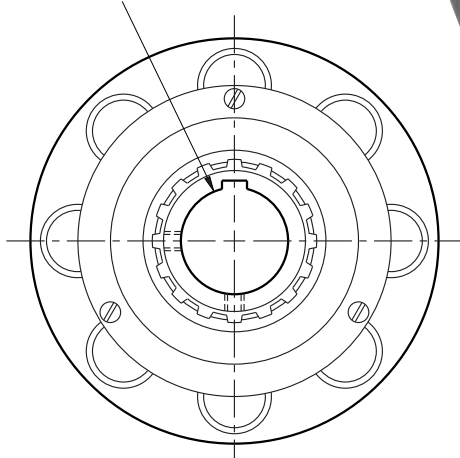

**ARMATURE VIEW**

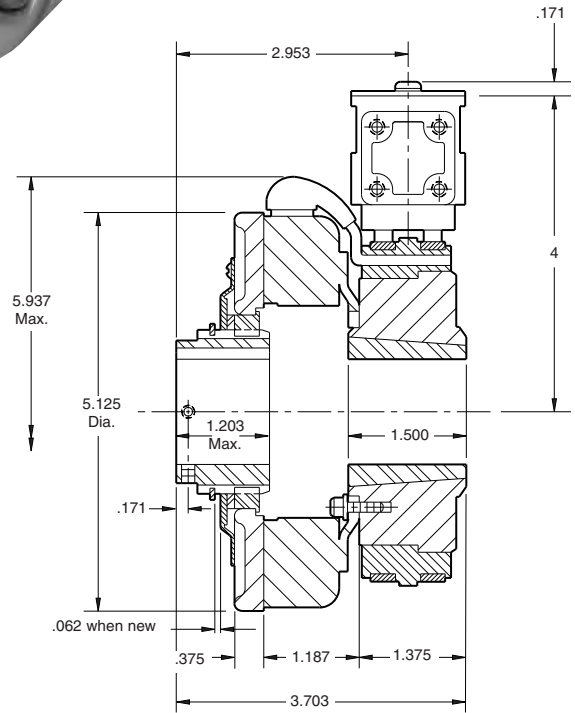

See page 252 for details on Bushings.

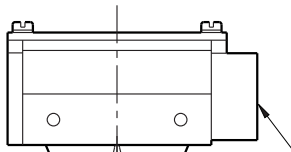

1/2-14 NPSM Am. std. straight pipe tap.

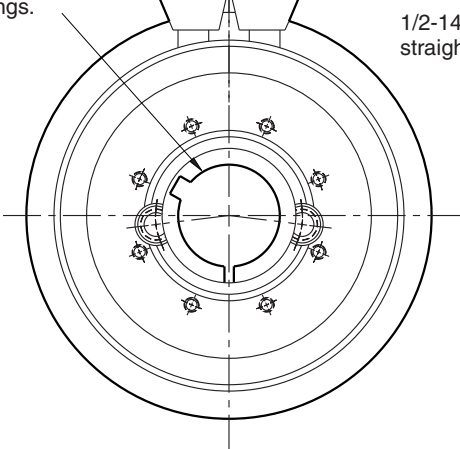

**COLLECTOR RING VIEW**

### Customer Shall Maintain:

1. Armature mounting shaft concentric with magnet mounting shaft within .006 T.I.R.

### Bore & Keyway Dimensions

Armature Bore Dia.	Keyway
.751/.750 .876/.875	.187 x .093
.9385/.9375 1.001/1.000 1.126/1.125 1.251/1.250	.250 x .125

Armature Shaft	.750 – 1.250
Magnet Shaft	.500 – 1.250
Static Torque	40 lb.ft.
Maximum Speed	5,400 rpm
Standard Voltage	D.C. 6, 24, 90

All dimensions are nominal unless otherwise noted.

Information on inertia and weights begins on page 239. Coil data is on pages 250 and 251.



# Clutch Coupling

## PCC-500 Heavy Duty

Drawing I-25543

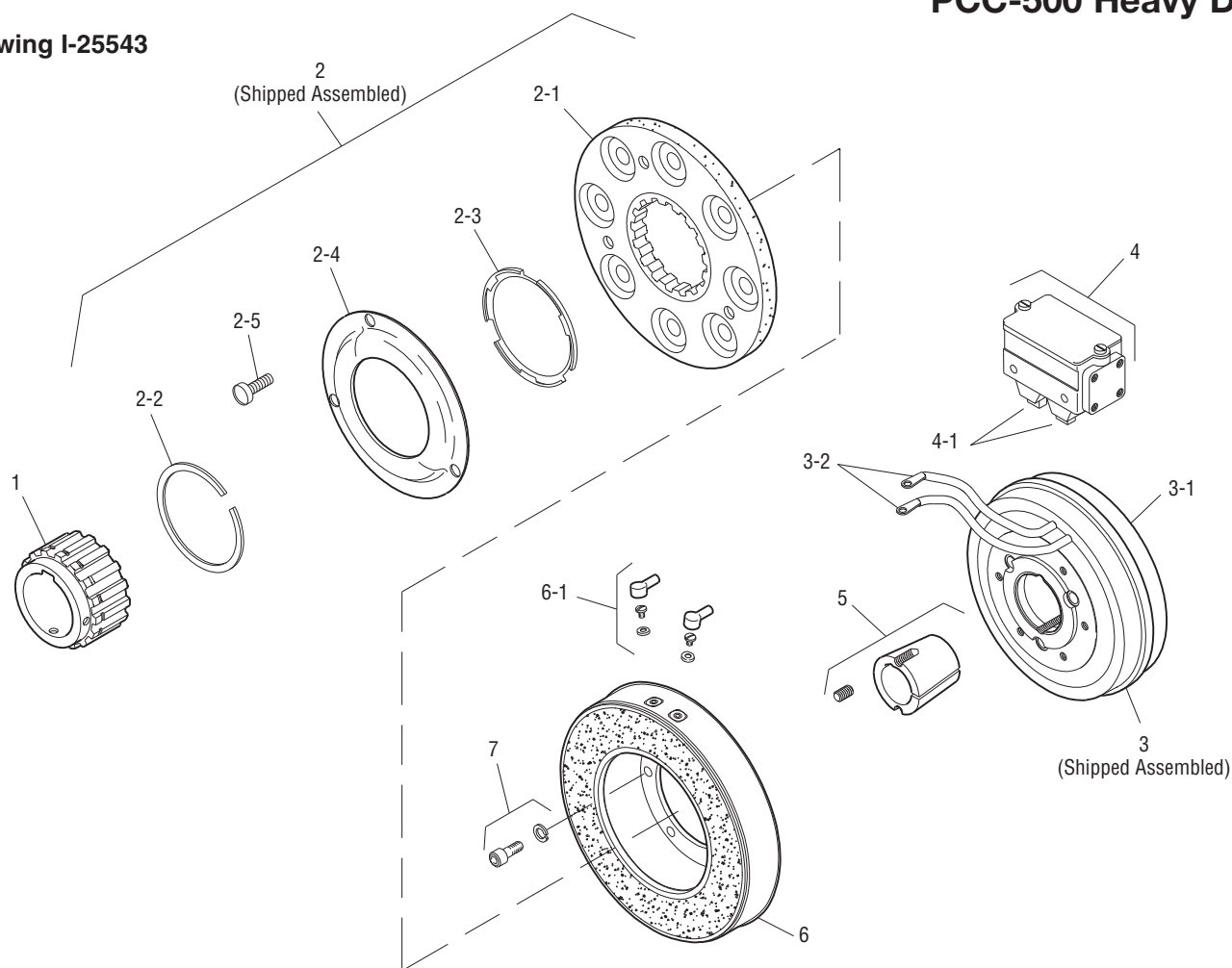

Item	Description	Part Number	Qty.
1	Armature Hub		1
	3/4" Bore	5200-541-002	
	7/8" Bore	5200-541-003	
	15/16" Bore	5200-541-004	
	1" Bore	5200-541-005	
	1-1/8" Bore	5200-541-006	
	1-1/4" Bore	5200-541-007	
2	Armature Assembly	5230-111-002	1
2-1	Armature	5230-111-001	1
2-2	Retainer Ring	748-0355	1
2-3	Autogap Spring	808-0412	1
2-4	Retainer Plate	748-0364	1
2-5	Screw	797-0028	3
3	Magnet Hub	5300-541-001	1
3-1	Collector Ring	5300-749-001	1
3-2	Collector Ring Mounting Acc.	5300-101-002	1
4	Brushholder	5300-178-001	1
4-1	Brush	176-0001	4
5	Bushing*		2
	1/2" to 1-1/4" Bore	180-0116 to 180-0128	

Item	Description	Part Number	Qty.
6	Magnet		1
	6 Volt	5300-631-002	
	24 Volt	5300-631-003	
	90 Volt	5300-631-005	
6-1	Terminal Accessory	5311-101-001	1
7	Mounting Accessory	5102-101-001	2

### How to Order:

1. Specify Bore Size for Item 1 and Item 5.
2. Specify Voltage for Item 6.
3. See Controls Section.

### Example:

PCC-500 Clutch Coupling per I-25543 - 90 Volt  
 3/4" Armature Hub Bore  
 1" Bushing Bore

These units meet standards set forth in UL508 and are listed under guide card #NMTR2, file #59164.

These units are CSA certified under file #LR11543.

\*See page 252 for specific part numbers.

Refer to Service Manual P-203.

# Clutch Coupling

## PCC-825

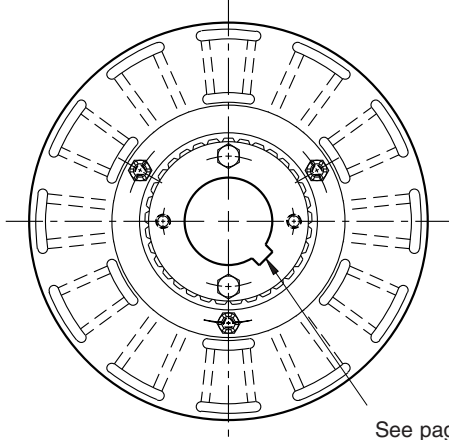

See page 252 for details on Bushings.

**ARMATURE VIEW**

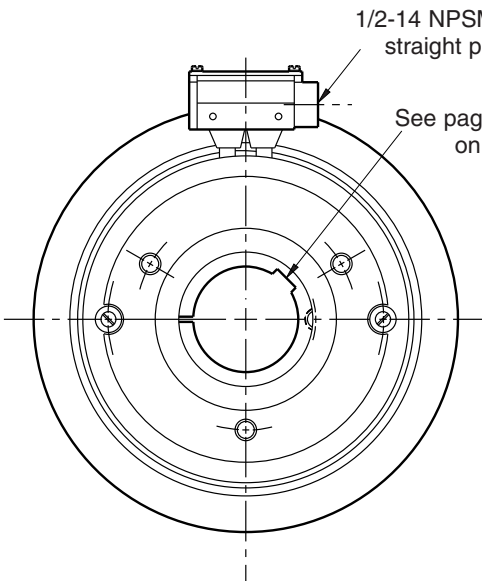

1/2-14 NPSM Am. std. straight pipe tap.

See page 252 for details on Bushings.

**COLLECTOR RING VIEW**

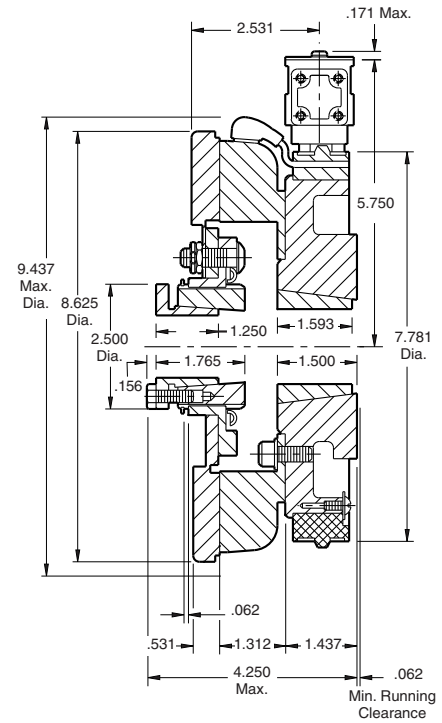

Armature Shaft	.500 – 1.500
Magnet Shaft	.500 – 1.625
Static Torque	125 lb.ft.
Maximum Speed	4,000 rpm
Standard Voltage	D.C. 6, 24, 90

### Customer Shall Maintain:

1. Armature mounting shaft concentric with magnet mounting shaft within .006 T.I.R.
2. Angular alignment of shafts within 1/2 degree.

All dimensions are nominal unless otherwise noted.

Information on inertia and weights begins on page 239. Coil data is on pages 250 and 251.



Drawing I-25565

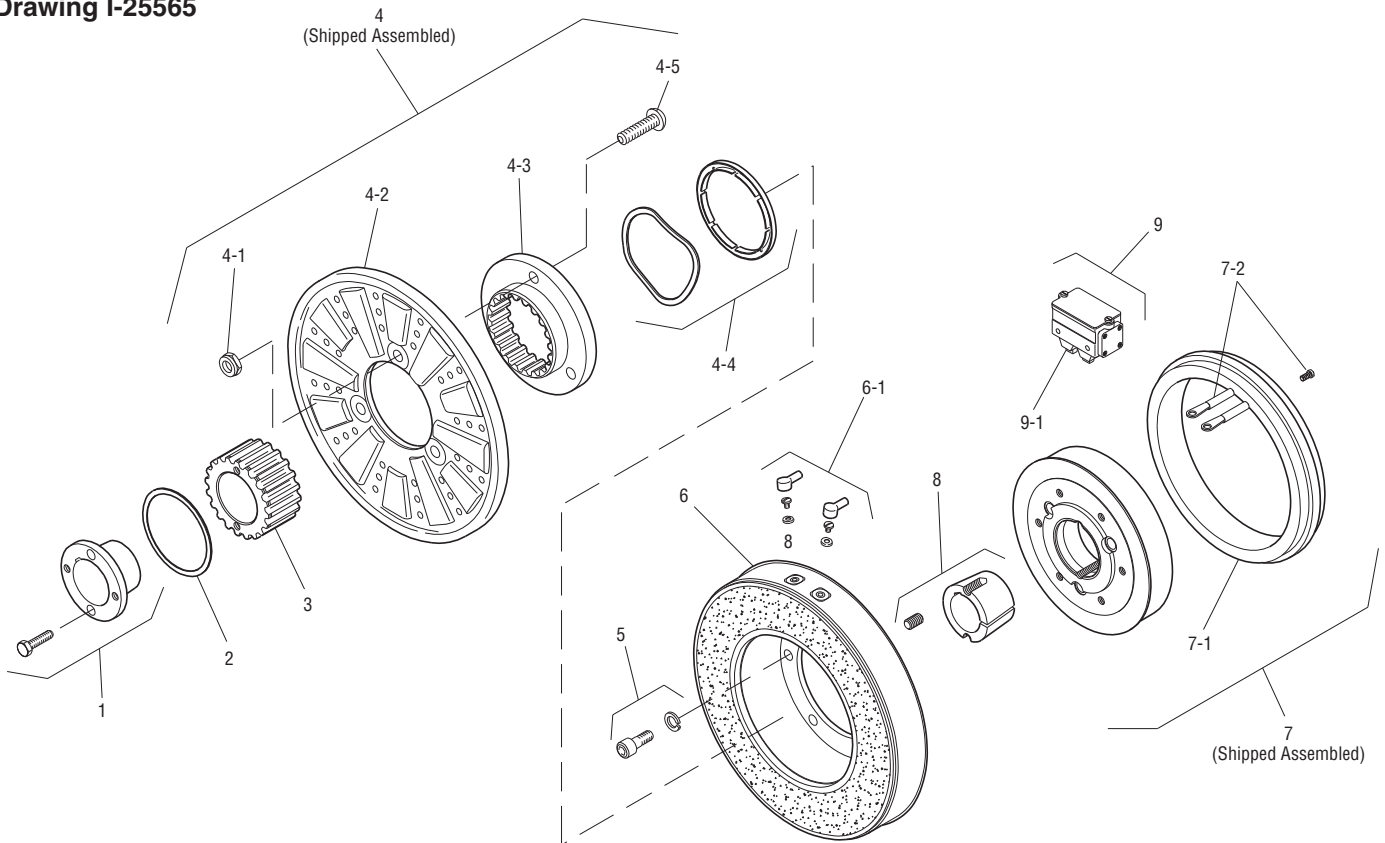

Item	Description	Part Number	Qty.
1	Bushing*		1
	1/2" to 1-1/2" Bore	180-0002 to 180-0018	
2	Retainer Ring	748-0006	1
3	Splined Hub	540-0057	1
4	Armature & Splined Adapter	5321-111-001	1
4-1	Locknut	661-0004	3
4-2	Armature	5321-111-022	1
4-3	Splined Adapter	104-0008	1
4-4	Autogap Accessory	5321-101-006	1
4-5	Screw	797-0272	3
5	Mounting Accessory	5321-101-001	1
6	Magnet		1
	6 Volt	5301-631-002	
	24 Volt	5301-631-004	
6-1	Terminal Accessory	5311-101-001	1
7	Magnet Hub		1
	Left Hand (shown)	5301-541-001	
	Right Hand	5301-541-002	
7-1	Collector Ring	5301-749-001	1
7-2	Collector Ring Accessory	5301-101-002	1
8	Bushing*		1
	1/2" to 1-5/8" Bore	180-0131 to 180-0149	

Item	Description	Part Number	Qty.
9	Brushholder	5300-178-001	1
9-1	Brush	176-0001	4

### How to Order:

1. Specify Bore Size for Item 1.
2. Specify Voltage for Item 6.
3. Specify left hand or right hand hub for Item 7. (Bushing enters from magnet side for L.H. hub and from hub side for R.H.)
4. Specify Bore Size for Item 8.
5. See Controls Section.

### Example:

PCC-825 Clutch Coupling per I-25565 - 90 Volt, L.H. hub, 1" Bore (Item 1), 1-1/2" Bore (Item 8)

These units meet the standards of UL508 and are listed under guide card #NMTR2, file #59164.

These units are CSA certified under file #LR11543

\*See page 252 for specific part numbers.

Refer to Service Manual P-206.

# Clutch Coupling

## PCC-1000

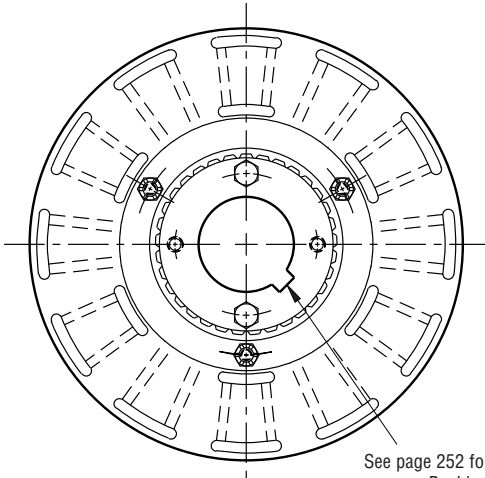

**ARMATURE VIEW**

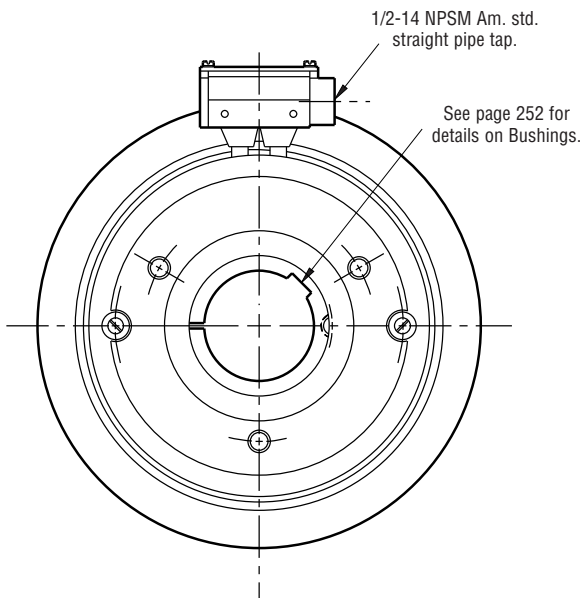

**COLLECTOR RING VIEW**

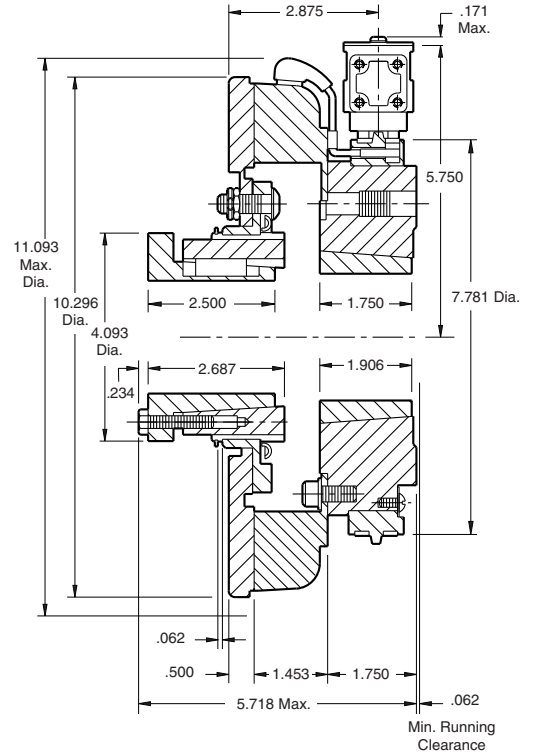

Armature Shaft	.750 – 2.687
Magnet Shaft	.500 – 2.500
Static Torque	240 lb.ft.
Maximum Speed	3,600 rpm
Standard Voltage	D.C. 6, 24, 90

All dimensions are nominal unless otherwise noted.

Information on inertia and weights begins on page 239. Coil data is on pages 250 and 251.

### Customer Shall Maintain:

1. Armature mounting shaft concentric with magnet mounting shaft within .006 T.I.R.
2. Angular alignment of shafts within 1/2 degree.



Drawing I-25585

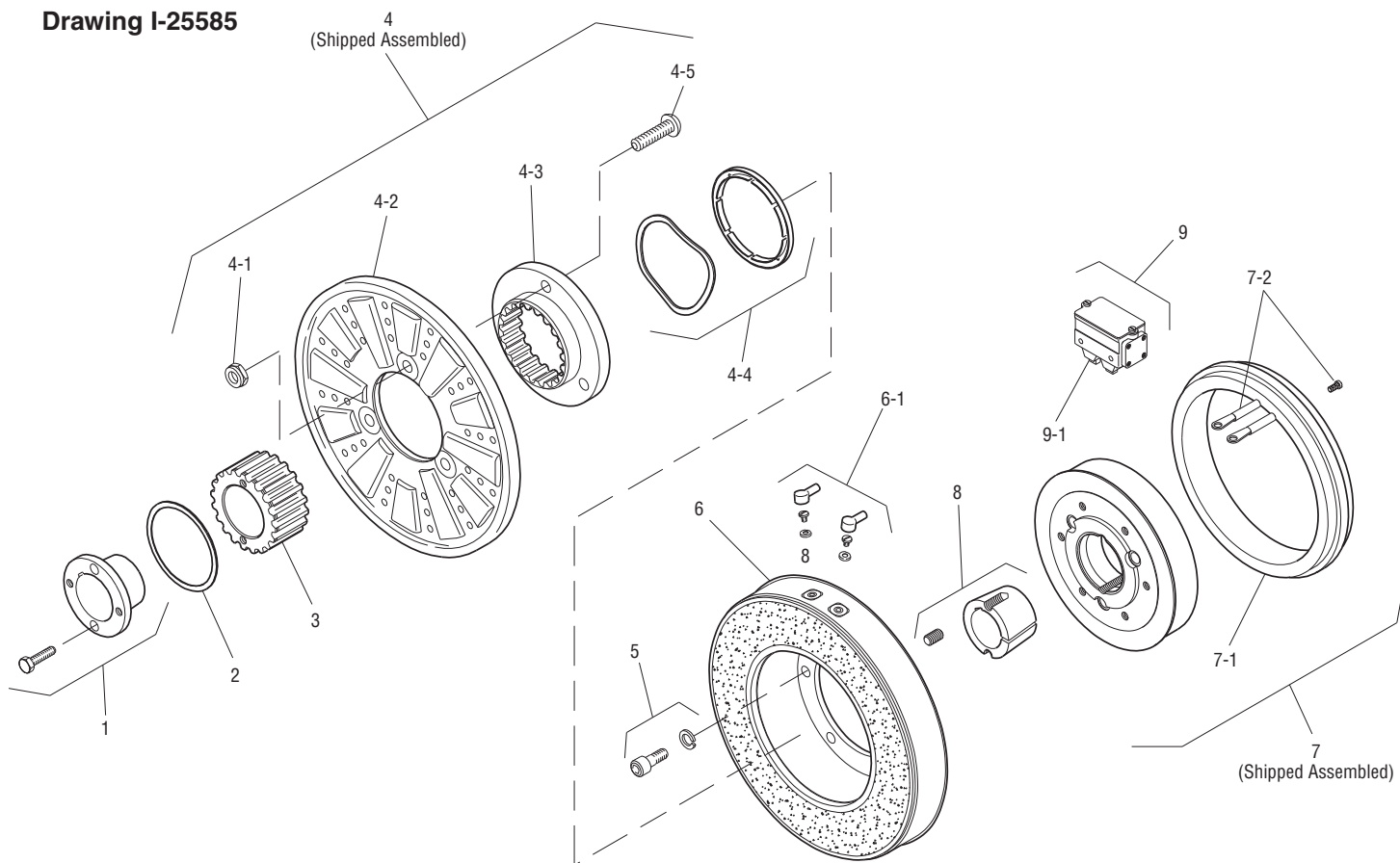

Item	Description	Part Number	Qty.
1	Bushing*		1
	3/4" to 2-11/16" Bore	180-0026 to 180-0057	
2	Retainer Ring	748-0007	1
3	Splined Hub	540-0062	1
4	Armature & Splined Adapter	5322-111-002	1
4-1	Locknut	661-0004	3
4-2	Armature	5322-111-036	1
4-3	Splined Adapter	104-0009	1
4-4	Autogap Accessory	5322-101-004	1
4-5	Screw	797-0272	3
5	Mounting Accessory	5321-101-001	1
6	Magnet		1
	6 Volt	5302-631-003	
	24 Volt	5302-631-014	
	90 Volt	5302-631-005	
6-1	Terminal Accessory	5311-101-001	1
7	Magnet Hub		1
	Left Hand (shown)	5302-541-001	
	Right Hand	5302-541-002	
7-1	Collector Ring	5301-749-001	1
7-2	Collector Ring Accessory	5302-101-002	1

Item	Description	Part Number	Qty.
8	Bushing*		1
	1/2" to 2-1/2" Bore	180-0185 to 180-0217	
9	Brushholder	5300-178-001	1
9-1	Brush	176-0001	4

### How to Order:

1. Specify Bore Size for Item 1.
2. Specify Voltage for Item 6.
3. Specify left hand or right hand hub for Item 7. (Bushing enters from magnet side for L.H. hub and from hub side for R.H.)
4. Specify Bore Size for Item 8.
5. See Controls Section.

### Example:

PCC-1000 Clutch Coupling per I-25585 - 90 Volt, L.H. hub, 1-1/2" Bore (Item 1), 2" Bore (Item 8)

These units meet the standards of UL508 and are listed under guide card #NMTR2, file #59164.

These units are CSA certified under file #LR11543

\*See page 252 for specific part numbers.

Refer to Service Manual P-206.

# Clutch Coupling

## PCC-1225

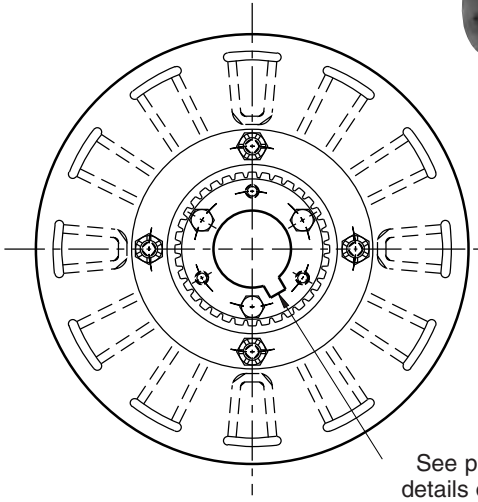

**ARMATURE VIEW**

See page 252 for details on Bushings.

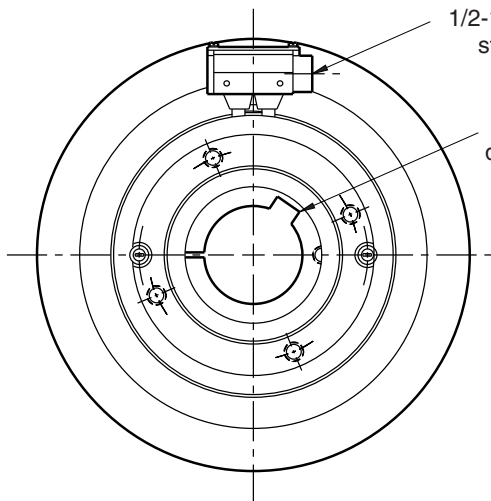

**PCC-1225  
COLLECTOR RING VIEW**

1/2-14 NPSM Am. std. straight pipe tap.

See page 252 for details on Bushings.

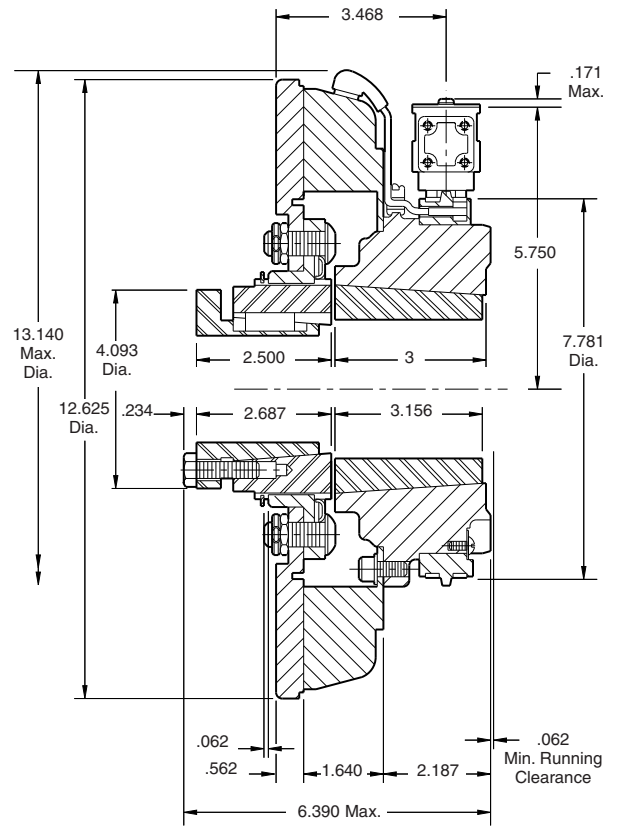

Armature Shaft	.750 – 2.687
Magnet Shaft	.937 – 3.00
Static Torque	465 lb.ft.
Maximum Speed	3,000 rpm
Standard Voltage	D.C. 6, 24, 90

### Customer Shall Maintain:

1. Armature mounting shaft concentric with magnet mounting shaft within .006 T.I.R.
2. Angular alignment of shafts within 1/2 degree.

All dimensions are nominal unless otherwise noted.

Information on inertia and weights begins on page 239. Coil data is on pages 250 and 251.





Drawing I-25605

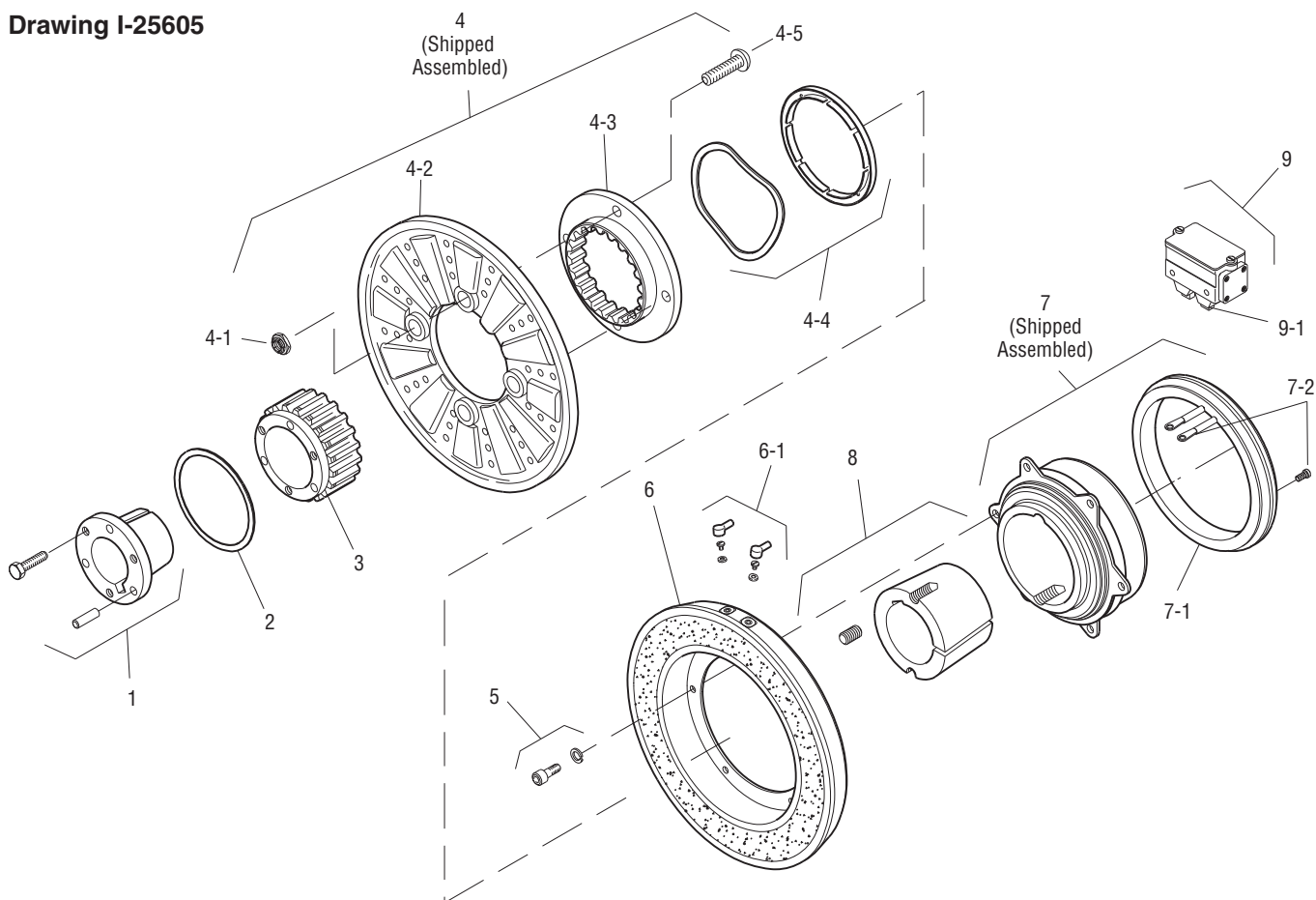

Item	Description	Part Number	Qty.
1	Bushing*		1
	3/4" to 2-11/16" Bore	180-0026 to 180-0057	
2	Retainer Ring	748-0005	1
3	Splined Hub	540-0064	1
4	Armature & Splined Adapter	5323-111-001	1
4-1	Locknut	661-0005	4
4-2	Armature	5323-111-034	1
4-3	Splined Adapter	104-0010	1
4-4	Autogap Accessory	5323-101-002	1
4-5	Screw	797-0281	4
5	Mounting Accessory	5321-101-001	1
6	Magnet		1
	6 Volt	5303-631-005	
	24 Volt	5303-631-007	
	90 Volt	5303-631-008	
6-1	Terminal Accessory	5311-101-001	1
7	Magnet Hub		1
	Left Hand (shown)	5303-541-001	
	Right Hand	5303-541-002	
7-1	Collector Ring	5301-749-001	1
7-2	Collector Ring Accessory	5303-101-004	1

Item	Description	Part Number	Qty.
8	Bushing*		1
	15/16" to 3" Bore	180-0262 to 180-0295	
9	Brushholder	5300-178-001	1
9-1	Brush	176-0001	4

### How to Order:

1. Specify Bore Size for Item 1.
2. Specify Voltage for Item 6.
3. Specify left hand or right hand hub for Item 7. (Bushing enters from magnet side for L.H. hub and from hub side for R.H.)
4. Specify Bore Size for Item 8.
5. See Controls Section.

### Example:

PCC-1225 Clutch Coupling per I-25605 - 90 Volt, L.H. hub, 1-1/2" Bore (Item 1), 2" Bore (Item 8)

These units meet the standards of UL508 and are listed under guide card #NMTR2, file #59164. These units are CSA certified under file #LR11543.

\*See page 252 for specific part numbers.

Refer to Service Manual P-206.

# Clutch Coupling

## PCC-1525

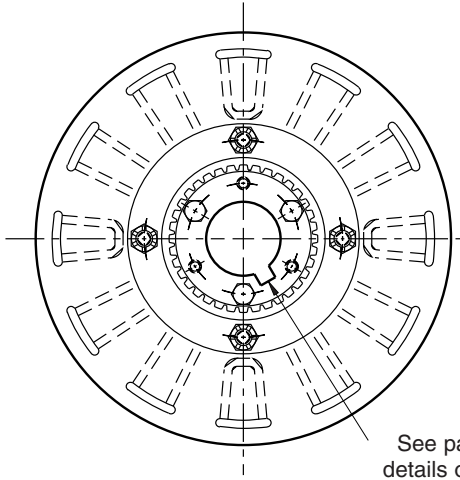

**ARMATURE VIEW**

See page 252 for details on Bushings.

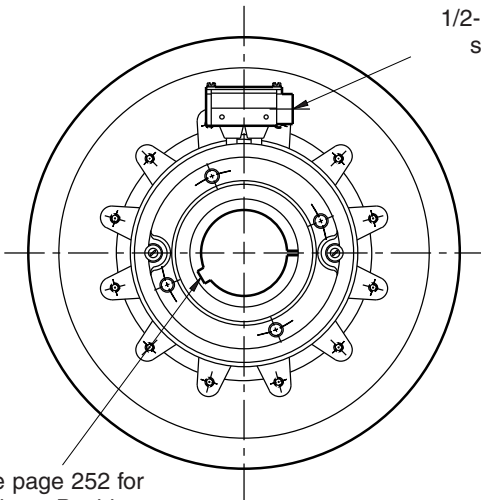

**PCC-1525  
COLLECTOR RING VIEW**

1/2-14 NPSM Am. std. straight pipe tap.

See page 252 for details on Bushings.

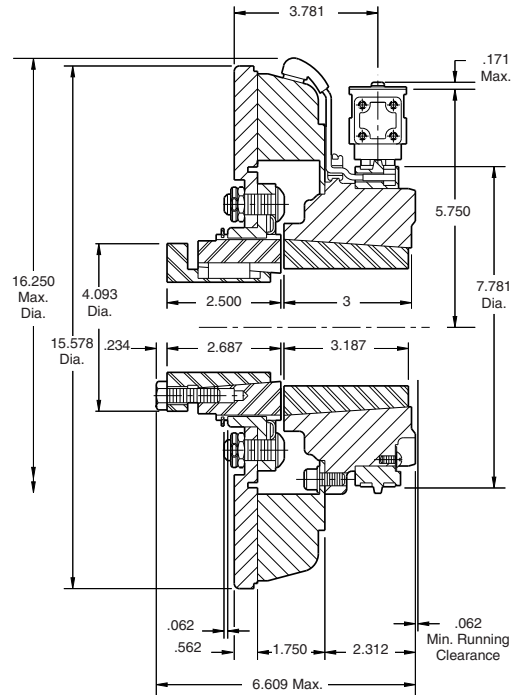

Armature Shaft	.750 – 2.687
Magnet Shaft	.937 – 3.00
Static Torque	700 lb.ft.
Maximum Speed	2,000 rpm
Standard Voltage	D.C. 6, 24, 90

### Customer Shall Maintain:

1. Armature mounting shaft concentric with magnet mounting shaft within .006 T.I.R.
2. Angular alignment of shafts within 1/2 degree.

All dimensions are nominal unless otherwise noted.

Information on inertia and weights begins on page 239. Coil data is on pages 250 and 251.



Drawing I-25632

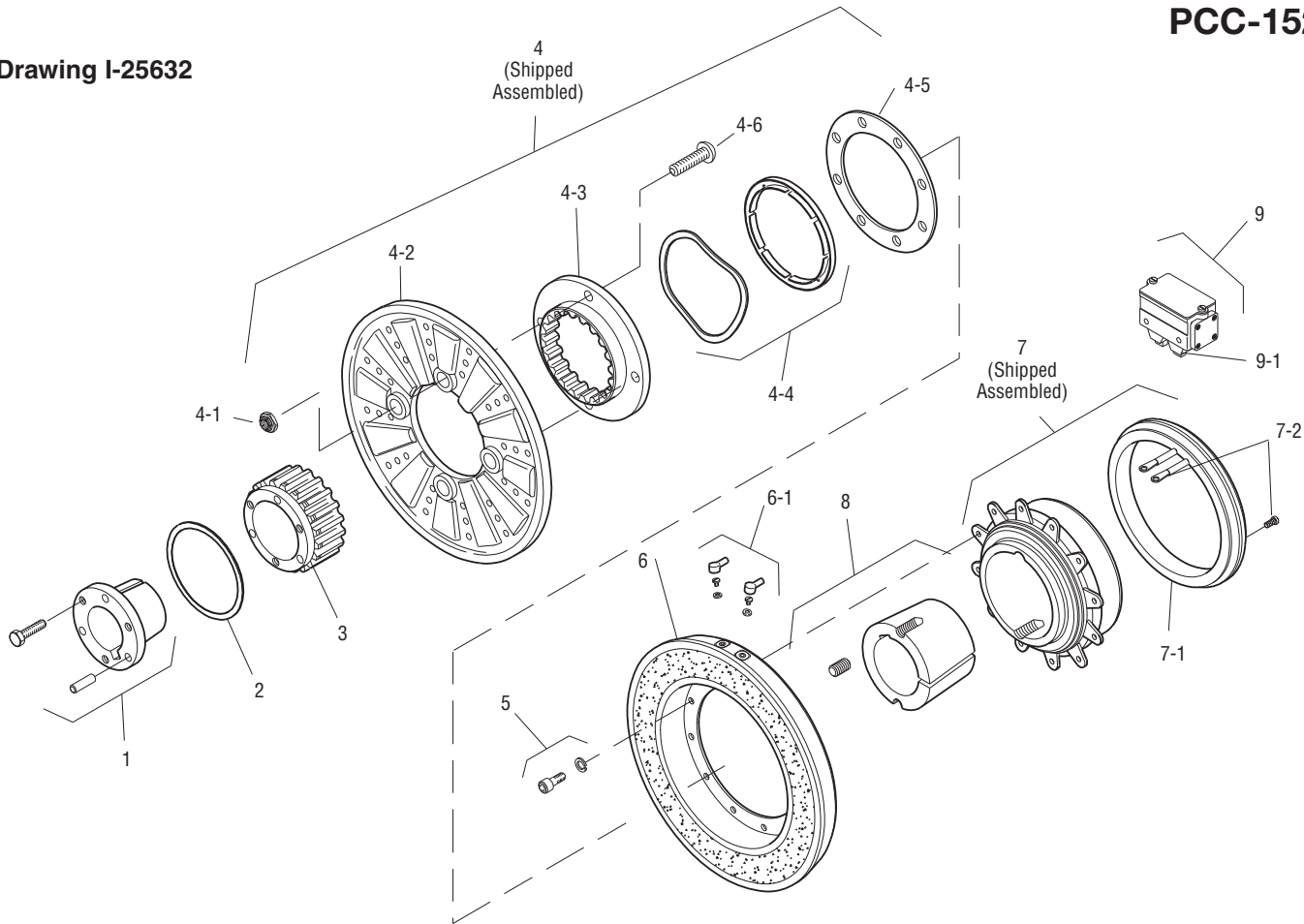

Item	Description	Part Number	Qty.
1	Bushing*		1
	3/4" to 2-11/16" Bore	180-0026 to 180-0057	
2	Retainer Ring	748-0005	1
3	Splined Hub	540-0064	1
4	Armature & Splined Adapter	5324-111-001	1
4-1	Locknut	661-0004	8
4-2	Armature	5324-111-034	1
4-3	Splined Adapter	104-0011	1
4-4	Autogap Accessory	5323-101-002	1
4-5	Retainer Plate	686-0003	1
4-6	Screw	797-0272	8
5	Mounting Accessory	5321-101-001	2
6	Magnet		1
	6 Volt	5304-631-009	
	24 Volt	5304-631-011	
	90 Volt	5304-631-010	
6-1	Terminal Accessory	5311-101-001	1
7	Magnet Hub		1
	Left Hand (shown)	5304-541-001	
	Right Hand	5304-541-002	
7-1	Collector Ring	5301-749-001	1
7-2	Collector Ring Accessory	5304-101-004	1

Item	Description	Part Number	Qty.
8	Bushing*		1
	15/16" to 3" Bore	180-0262 to 180-0295	
9	Brushholder	5300-178-001	1
9-1	Brush	176-0001	4

**How to Order:**

1. Specify Bore Size for Item 1.
2. Specify Voltage for Item 6.
3. Specify left hand or right hand hub for Item 7. (Bushing enters from magnet side for L.H. hub and from hub side for R.H.)
4. Specify Bore Size for Item 8.
5. See Controls Section.

**Example:**

PCC-1525 Clutch Coupling per I-25632 - 90 Volt, L.H. hub, 1-1/2" Bore (Item 1), 2" Bore (Item 8)

These units meet the standards of UL508 and are listed under guide card #NMTR2, file #59164.

These units are CSA certified under file #LR11543.

\*See page 252 for specific part numbers.

Refer to Service Manual P-206.

# Brake

## PB-120

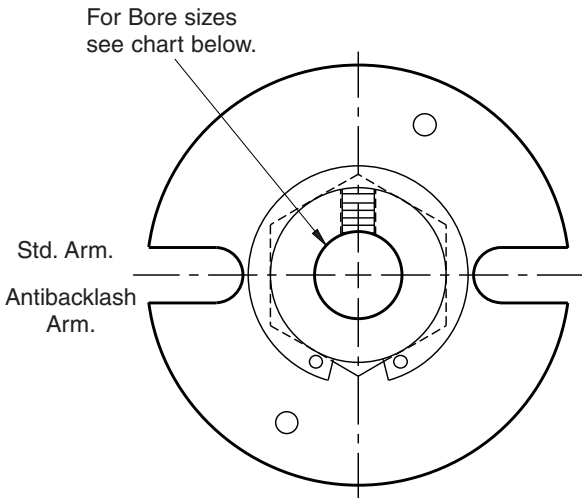
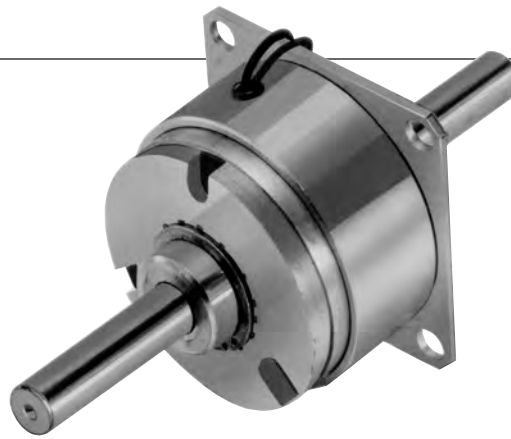

**ARMATURE VIEW**

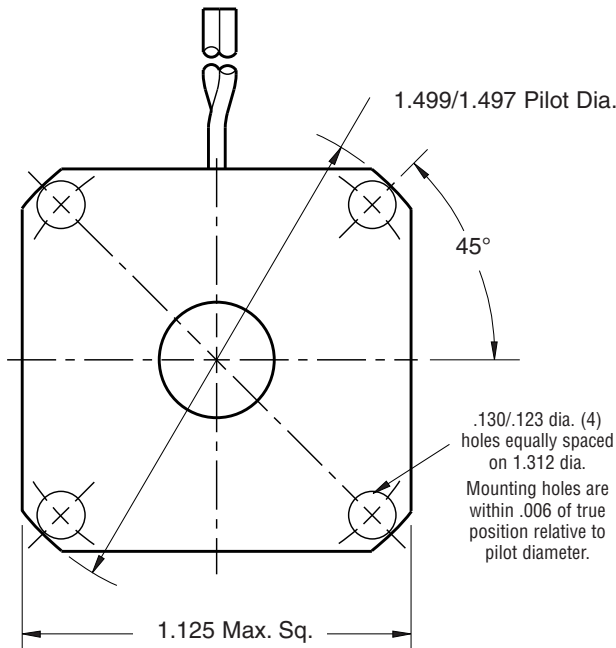

**MAGNET VIEW**

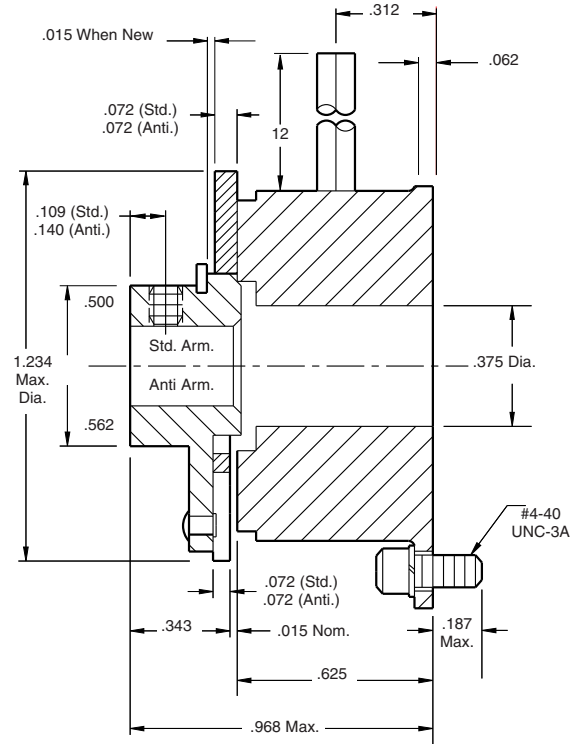

### Bore Dimensions

Armature Bore Dia.
.188/.187
.251/.250
(.313/.312)*

\*(Antibrake Armatures)

### Customer Shall Maintain:

1. Concentricity of brake mounting pilot diameter with armature shaft within .003 T.I.R.
2. Squareness of brake mounting face with armature shaft within .003 T.I.R.



Static Torque	5 lb.in.
Maximum Speed	10,000 rpm
Standard Voltage	D.C. 6, 24, 90

All dimensions are nominal unless otherwise noted.

Information on inertia and weights begins on page 239. Coil data is on pages 250 and 251.

**Drawing I-25507**

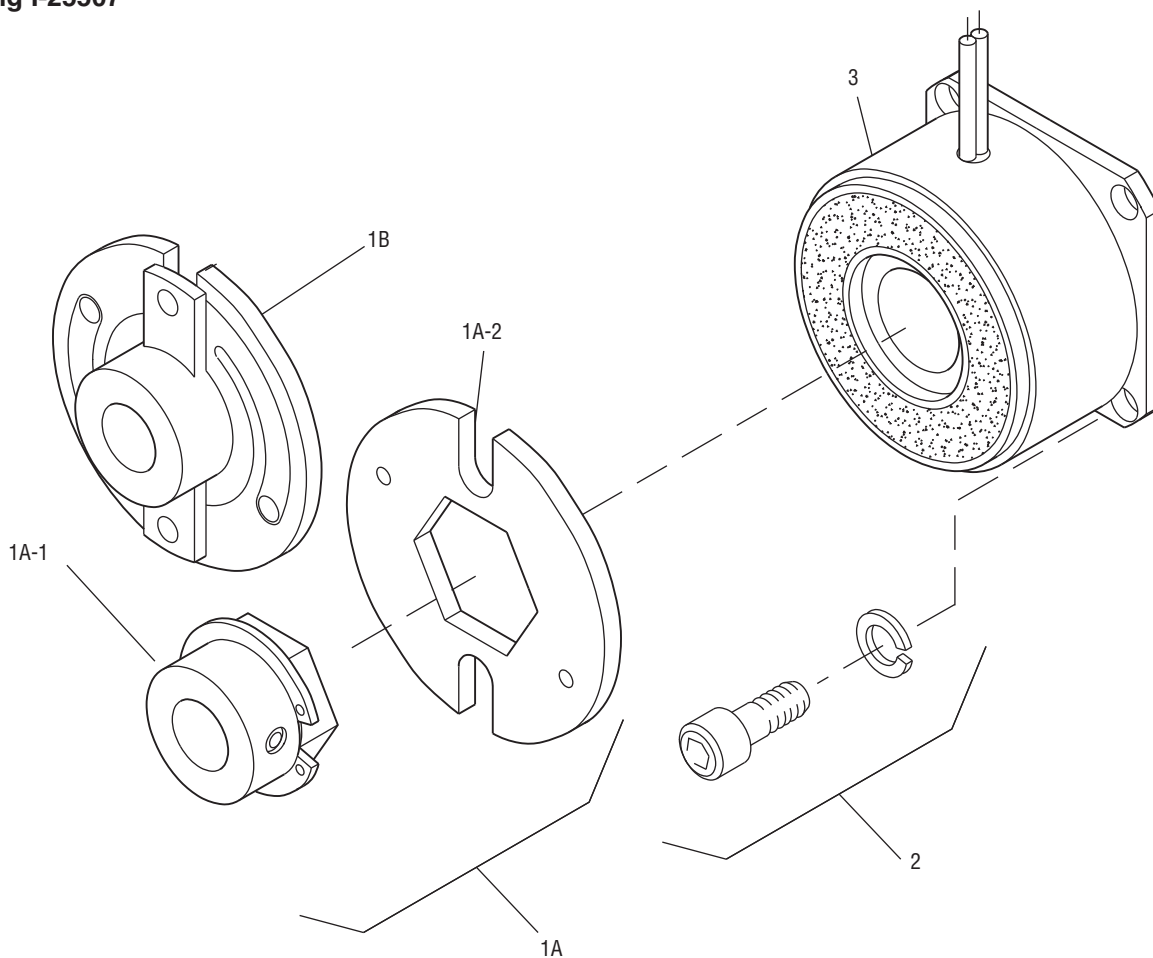

Item	Description	Part Number	Qty.
1A	Armature and Hub		
1A-1	Armature Hub		1
	3/16" Bore	5622-541-009	
	1/4" Bore	5622-541-008	
1A-2	Armature	110-0110	1
1B	Antibrake Armature		1
	3/16" Bore	5622-111-004	
	1/4" Bore	5622-111-002	
	5/16" Bore	5622-111-003	
2	Mounting Accessory	5101-101-001	1
3	Magnet		1
	6 Volt	5373-631-003	
	24 Volt	5373-631-005	
	90 Volt	5373-631-007	

**How to Order:**

1. Specify Type of Armature Desired.
2. Specify Bore Size for Item 1A-1 or 1B.
3. Specify Voltage for Item 3.
4. See Controls Section.

**Example:**

PB-120 Brake per I-25507 - 90 Volt,  
Standard Armature 3/16" Hub Bore  
These units meet the standards of UL508 and are listed  
under guide card #NMTR, file #59164.

These units are CSA certified under file #LR11543.

Refer to Service Manual P-201.

# Brake

## PB-170

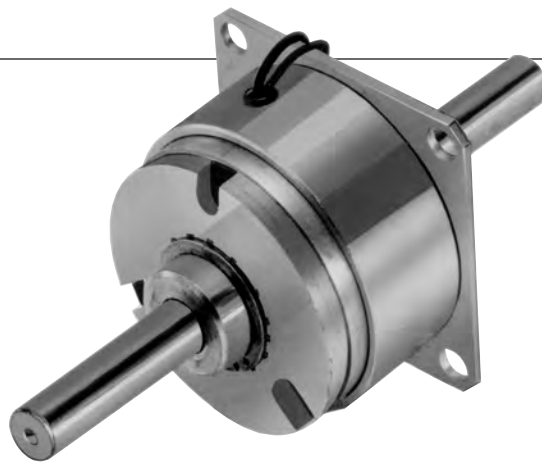

For Bore sizes see chart below.

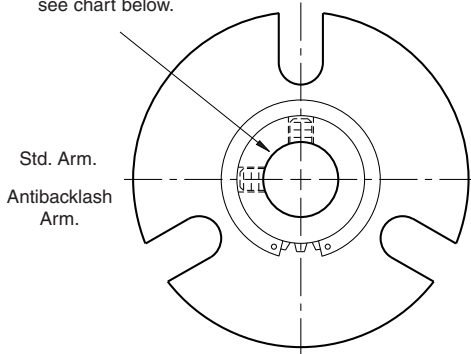

**ARMATURE VIEW**

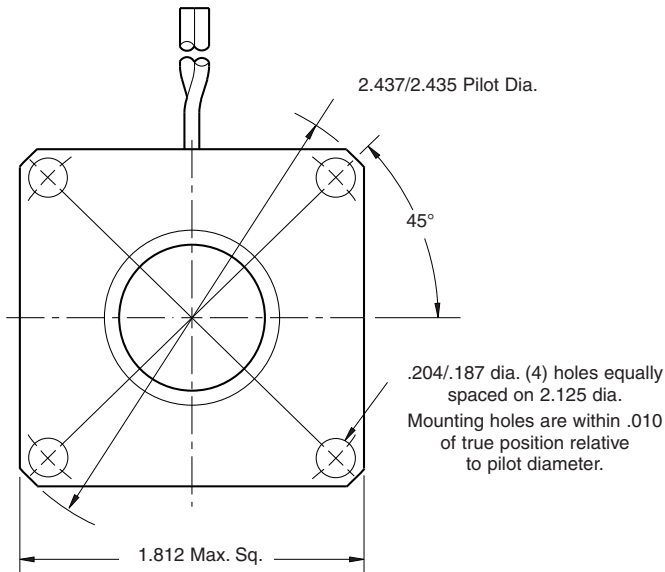

**MAGNET VIEW**

### Customer Shall Maintain:

1. Squareness of brake mounting face with armature shaft within .006 T.I.R.
2. Concentricity of brake mounting pilot diameter with armature shaft within .010 T.I.R.

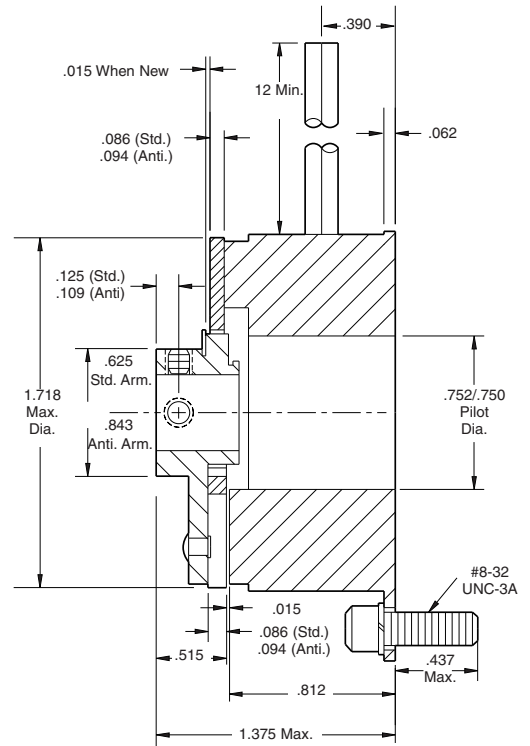

### Bore Dimensions

Armature Bore Dia.
.251/.250
.313/.312
.376/.375

Static Torque	15 lb.in.
Maximum Speed	10,000 rpm
Standard Voltage	D.C. 6, 24, 90

All dimensions are nominal unless otherwise noted.

Information on inertia and weights begins on page 239. Coil data is on pages 250 and 251.



**Drawing I-25753**

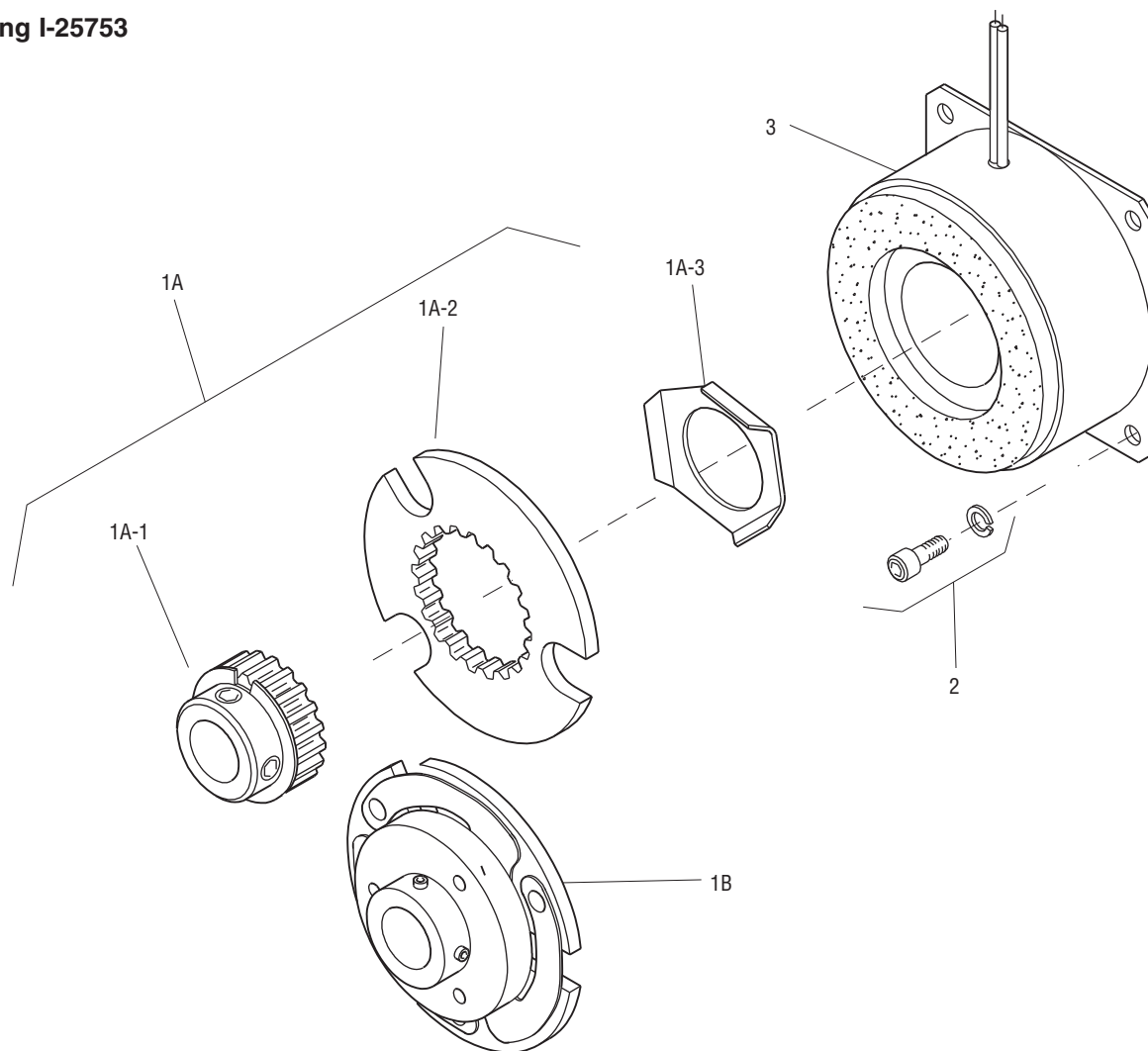

Item	Description	Part Number	Qty.
1A	Armature and Hub		
1A-1	Armature Hub		1
	1/4" Bore	5102-541-002	
	5/16" Bore	5102-541-003	
	3/8" Bore	5102-541-004	
1A-2	Armature	110-0111	1
1A-3	Release Spring	808-0019	1
1B	Antibacklash Armature		1
	1/4" Bore	5623-111-008	
	5/16" Bore	5623-111-009	
	3/8" Bore	5623-111-010	
2	Mounting Accessory	5102-101-001	1
3	Magnet		1
	6 Volt	5375-631-003	
	24 Volt	5375-631-005	
	90 Volt	5375-631-007	

**How to Order:**

1. Specify Type of Armature Desired.
2. Specify Bore Size for Item 1A-1 or 1B.
3. Specify Voltage for Item 3.
4. See Controls Section.

**Example:**

PB-170 Brake per I-25753 - 90 Volt,  
Antibacklash Armature  
1/4" Armature Hub Bore

These units meet the standards of UL508 and are listed under guide card #NMTR2, file #59164.

These units are CSA certified under file #LR11543.

Refer to Service Manual P-201.

# Brake

## PB-250 Flange Mounted

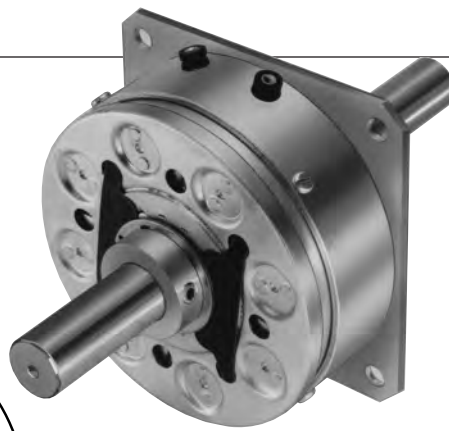

For Bore & Keyway sizes  
see chart below.

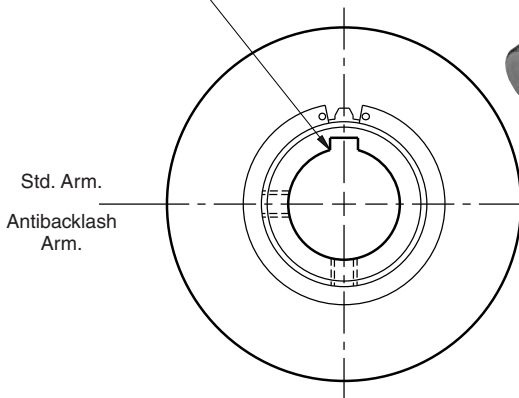

**ARMATURE VIEW**

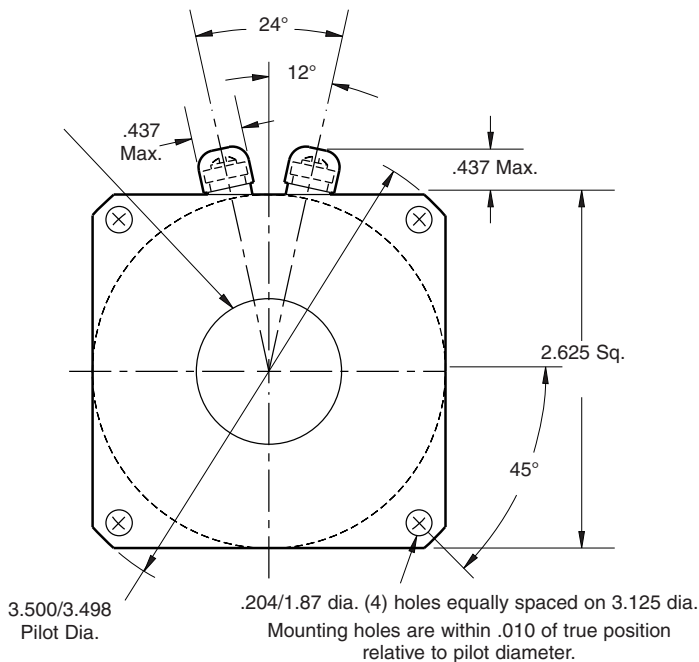

**FIELD VIEW**

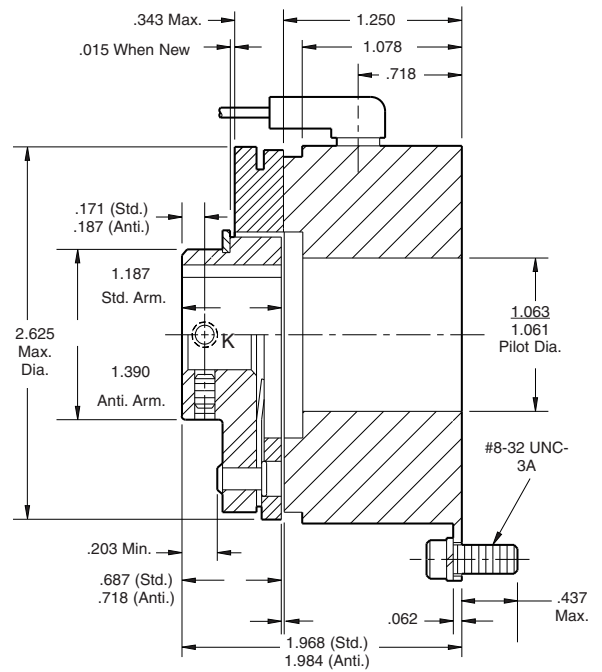

### Bore and Keyway Dimensions

Armature Bore Dia.	Keyway
.376/.375	.093 x .046
.438/.437*	.125 x .062
.501/.500	.125 x .062
.563/.562*	
.626/.625	
.688/.687*	.187 x .093
.751/.750	

\* Available on special order only.

### Customer Shall Maintain:

1. Squareness of brake mounting face with armature hub shaft within .006 T.I.R.
2. Concentricity of brake mounting pilot diameter with armature shaft within .010 T.I.R.

Static Torque	70 lb.in.
Maximum Speed	7,500 rpm
Standard Voltage	D.C. 6, 24, 90

All dimensions are nominal unless otherwise noted.

Information on inertia and weights begins on page 239. Coil data is on pages 250 and 251.





**PB-250 Flange Mounted**

**Drawing I-25519**

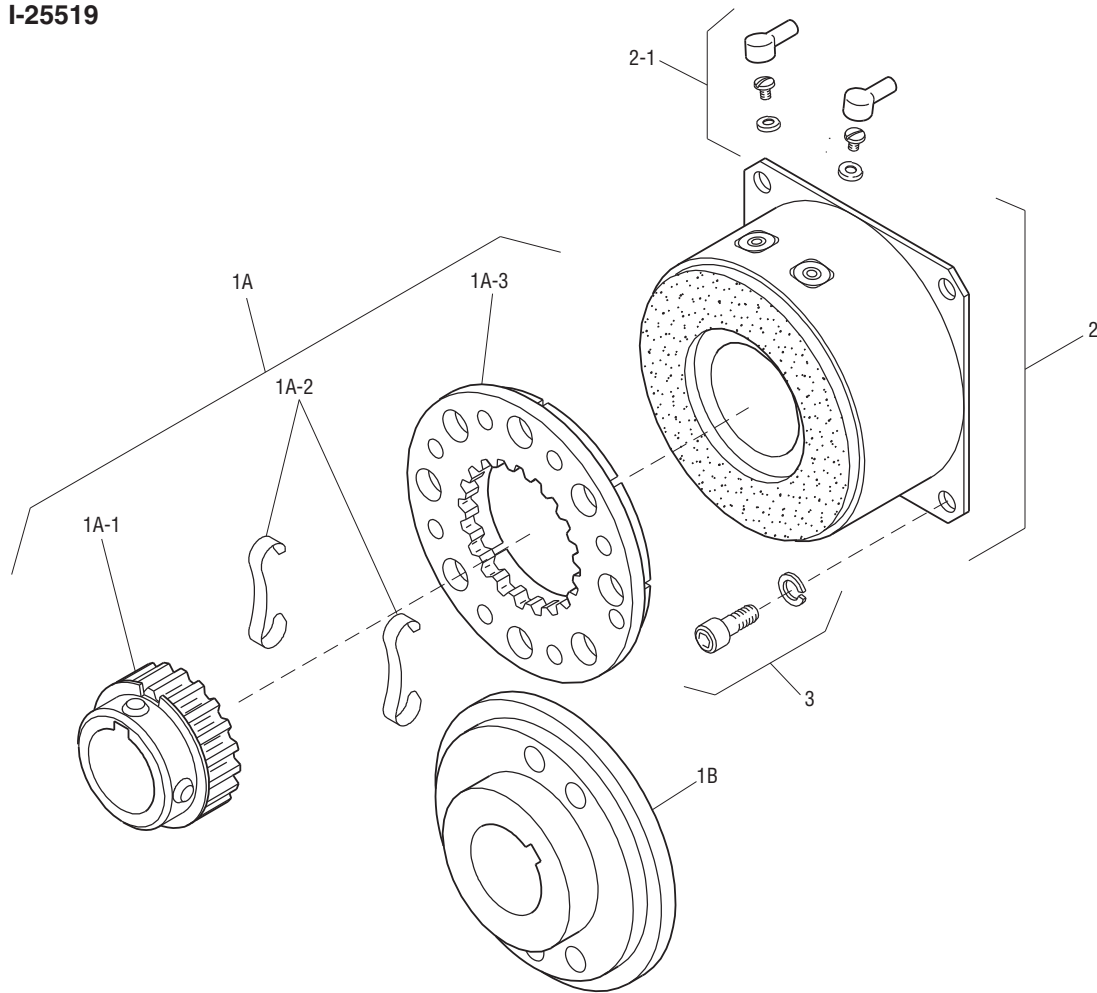

Item	Description	Part Number	Qty.
1A	Armature and Hub		
1A-1	Armature Hub		1
	3/8" Bore	5103-541-002	
	1/2" Bore	5103-541-004	
	5/8" Bore	5103-541-006	
	3/4" Bore	5103-541-008	
1A-2	Release Spring	5103-101-003	1
1A-3	Armature	5124-111-001	1
1B	Antibacklash Armature		1
	3/8" Bore	5365-111-003	
	1/2" Bore	5365-111-005	
	5/8" Bore	5365-111-007	
	3/4" Bore	5365-111-009	
2	Magnet		1
	6 Volt	5319-631-002	
	24 Volt	5319-631-003	
	90 Volt	5319-631-005	
2-1	Terminal Accessory	5103-101-002	1
3	Mounting Accessory	5102-101-001	1

**How to Order:**

1. Specify Type of Armature Desired.
2. Specify Bore Size for Item 1A-1 and 1-B.
3. Specify Voltage for Item 2.
4. See Controls Section.

**Example:**

PB-250 Brake per I-25519 - 90 Volt,  
Standard Armature  
1/2" Armature Hub Bore

These units meet the standards of UL508 and are listed under guide card #NMTR2, file #59164.

These units are CSA certified under file #LR11543.

Refer to Service Manual P-201.

# Brake

## PB-400 Flange Mounted



For Bore & Keyway sizes see chart below.

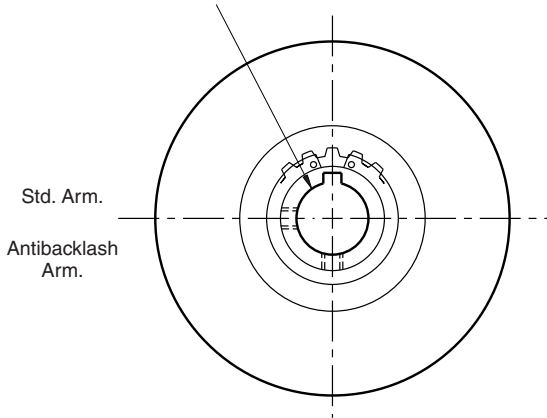

**ARMATURE VIEW**

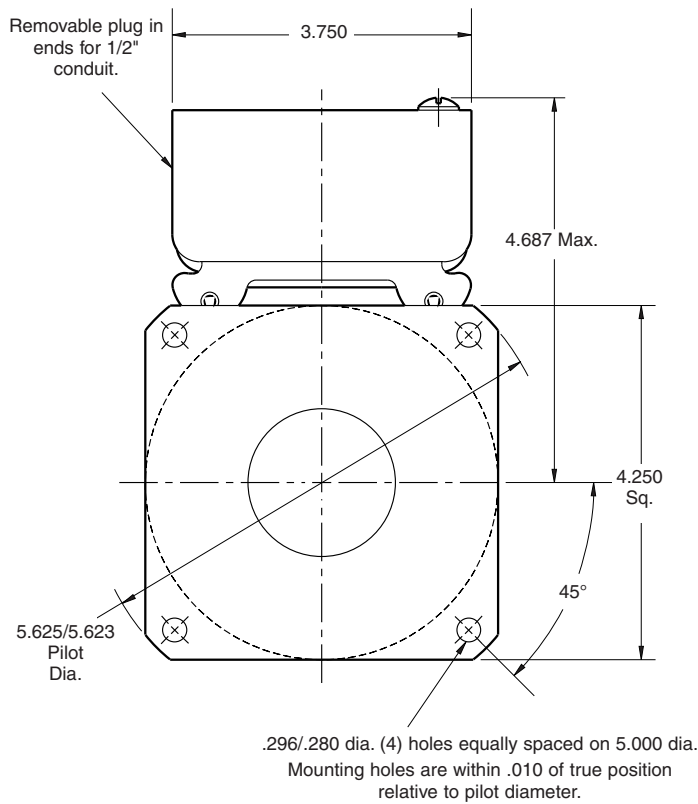

**FIELD VIEW**

### Customer Shall Maintain:

1. Squareness of brake mounting face with armature hub shaft within .006 T.I.R.
2. Concentricity of brake mounting pilot diameter with armature shaft within .010 T.I.R.

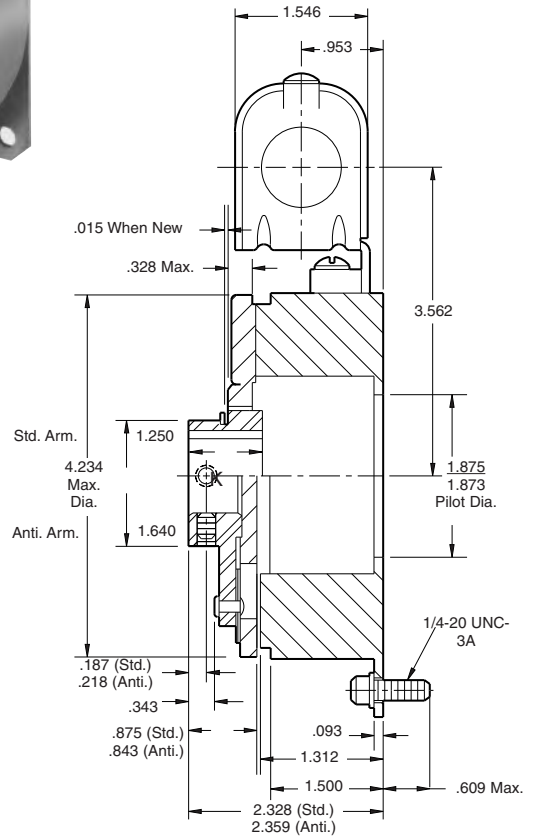

### Bore and Keyway Dimensions

Armature Bore Dia.	Keyway
.501/.500	.125 x .062
.563/.562*	
.626/.625	
.688/.687*	
.751/.750	.187 x .093
.876/.875	

\* Available on special order only.

Static Torque	270 lb.in.
Maximum Speed	4,500 rpm
Standard Voltage	D.C. 6, 24, 90

All dimensions are nominal unless otherwise noted.

Information on inertia and weights begins on page 239. Coil data is on pages 250 and 251.

**PB-400 Flange Mounted**

**Drawing I-25694**

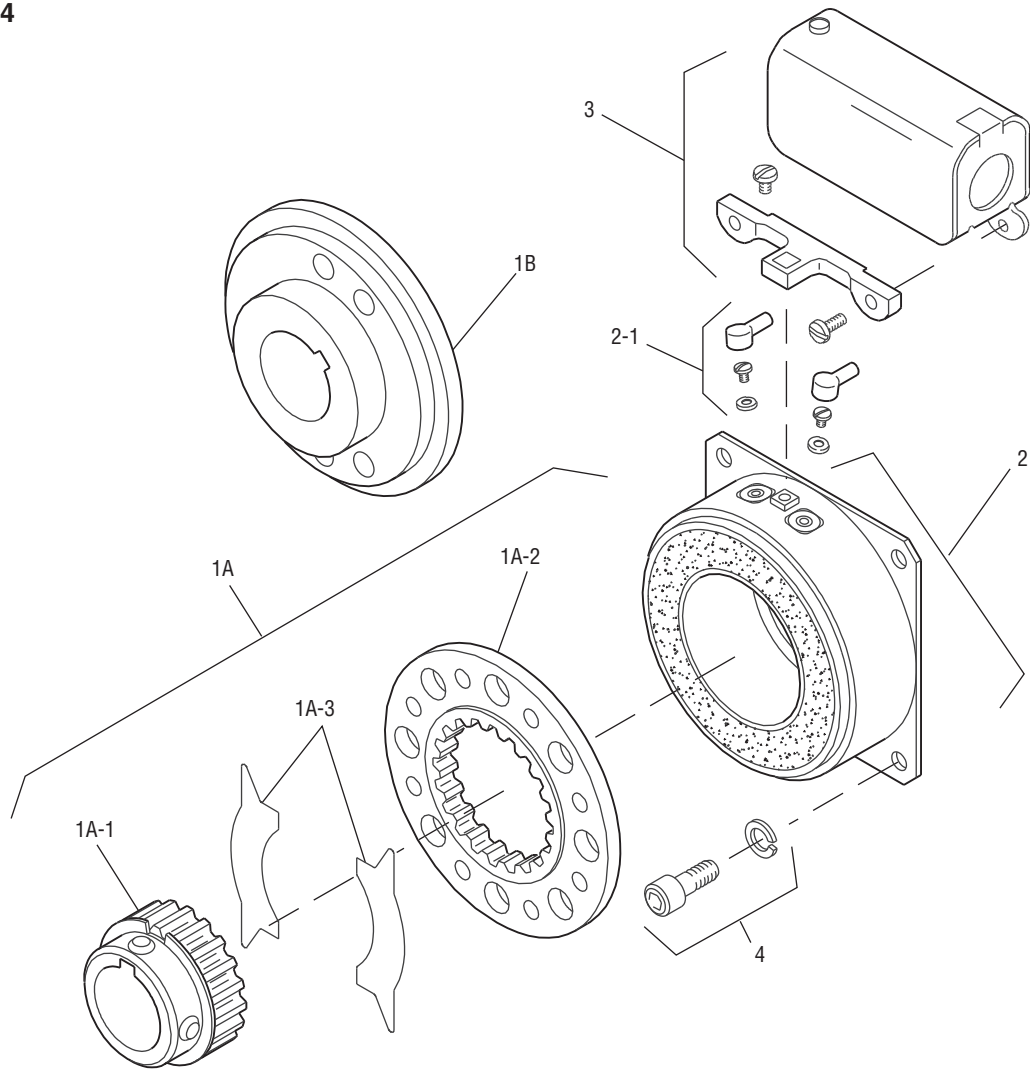

Item	Description	Part Number	Qty.
1A	Armature and Hub		
1A-1	Armature Hub		1
	1/2" Bore	5104-541-002	
	5/8" Bore	5104-541-004	
	3/4" Bore	5104-541-006	
	7/8" Bore	5104-541-007	
1A-2	Armature	5125-111-001	1
1A-3	Release Spring	5104-101-003	1
1B	Antibacklash Armature		1
	1/2" Bore	5367-111-003	
	5/8" Bore	5367-111-005	
	3/4" Bore	5367-111-007	
	7/8" Bore	5367-111-008	
2	Magnet		1
	6 Volt	5115-631-002	
	24 Volt	5115-631-003	
	90 Volt	5115-631-004	

Item	Description	Part Number	Qty.
2-1	Terminal Accessory	5103-101-002	1
3	Conduit Box	5200-101-010	1
4	Mounting Accessory	5104-101-002	1

**How to Order:**

1. Specify Type of Armature Desired.
2. Specify Bore Size for Item 1A-1 or 1B.
3. Specify Voltage for Item 2.
4. See Controls Section.

**Example:**

PB-400 Brake per I-25694 - 90 Volt,  
Antibacklash Armature  
3/4" Armature Hub Bore

These units meet standards set forth in UL508 and are listed under guide card #NMTR, file #59164. These units are CSA certified under file #LR11543.

Refer to Service Manual P-201.

# Brake

## PB-500 Normal Duty

See page 252 for details on Bushings.

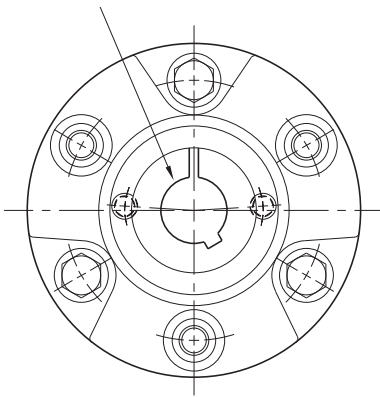

**HUB VIEW**

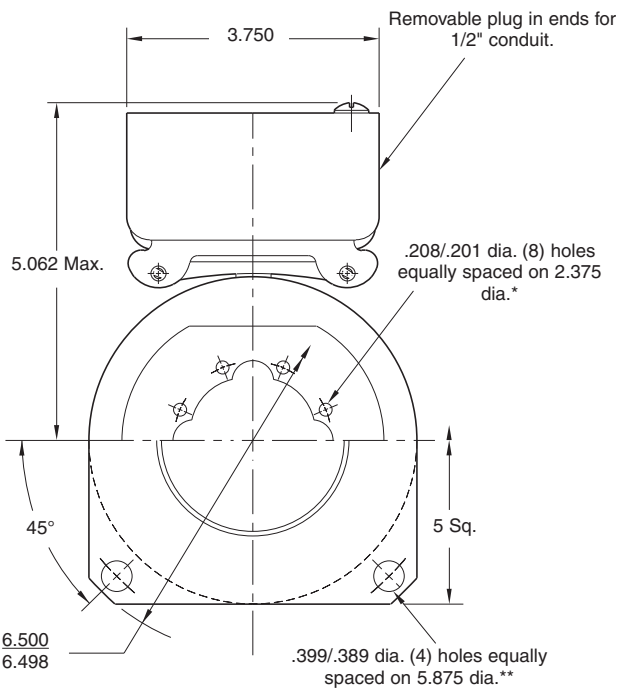

**MAGNET VIEW  
(Inside & Outside Mounted)**

- \* Mounting holes are within .010 of true position relative to pilot diameter.
- \*\* Mounting holes are within .008 of true position relative to pilot diameter.

**Customer Shall Maintain:**

1. Squareness of brake mounting face with armature hub shaft within .006 T.I.R.
2. Concentricity of brake mounting pilot diameter with armature hub shaft within .010 T.I.R

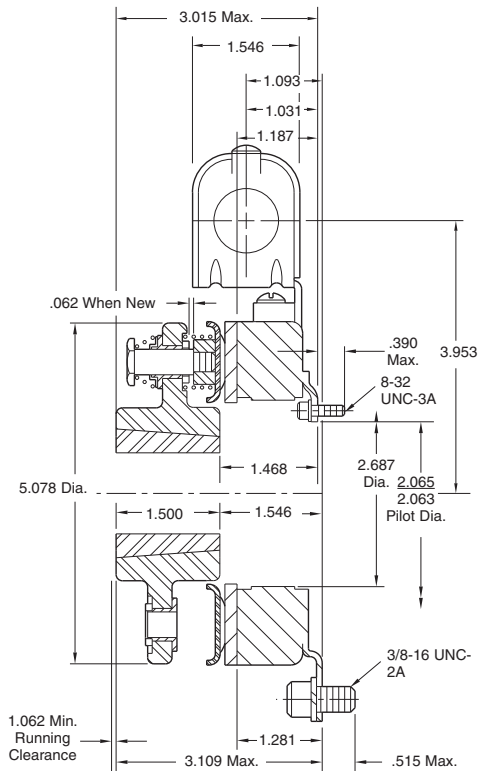

**Outside Mounted Offset Backing Plate**

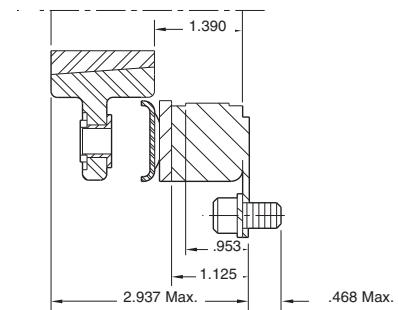

**Outside Mounted Flush Backing Plate**

Static Torque	40 lb.ft.
Maximum Speed	5,400 rpm
Standard Voltage	D.C. 6, 24, 90

All dimensions are nominal unless otherwise noted.

Information on inertia and weights begins on page 239. Coil data is on pages 250 and 251.

Drawing I-25544

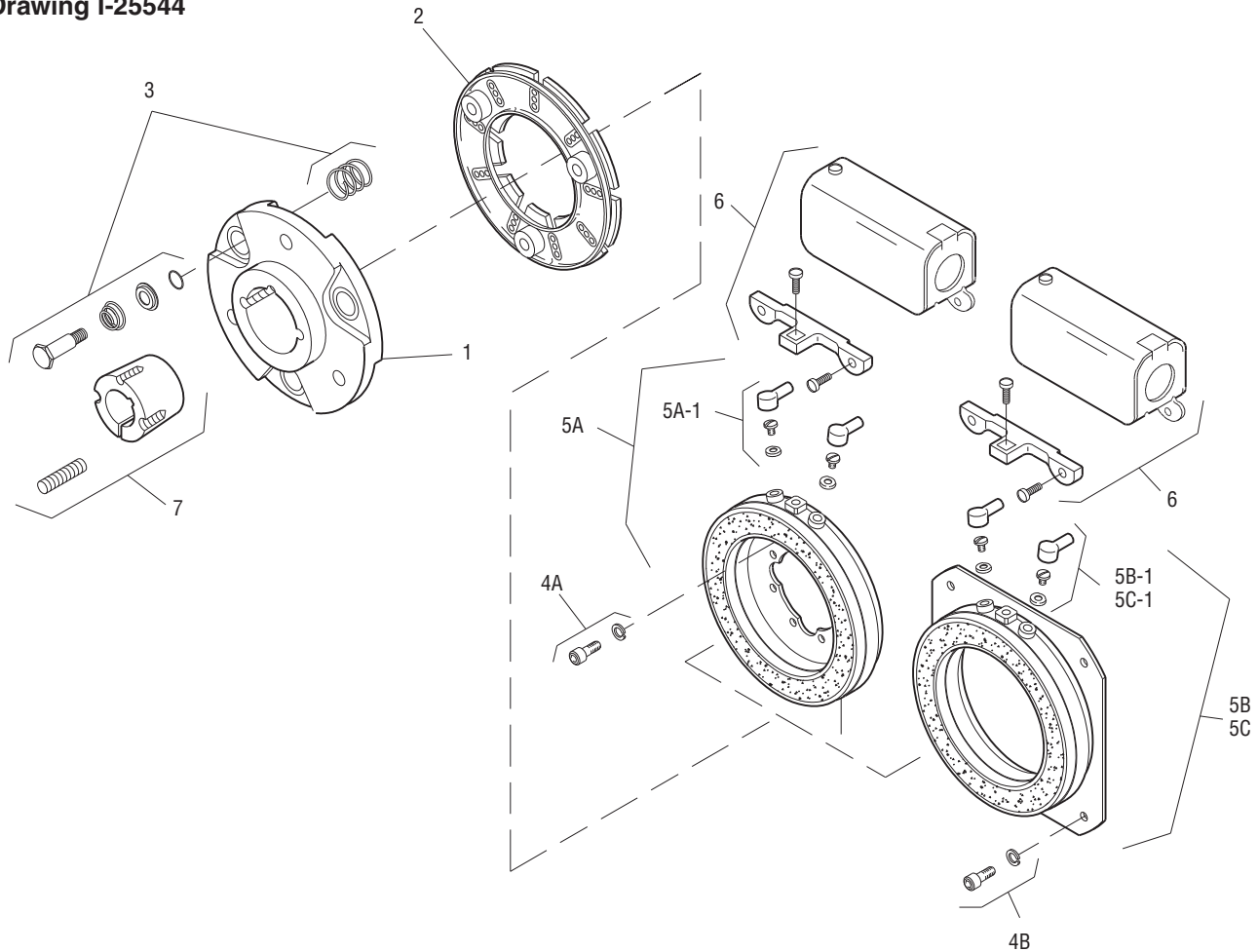

Item	Description	Part Number	Qty.
1	Armature Hub	5300-541-004	1
2	Armature	5300-111-002	1
3	Autogap Accessory	5200-101-009	3
4A	Mounting Accessory - I.M.	5102-101-001	2
4B	Mounting Accessory - O.M.	5300-101-008	1
5A	Magnet - I.M.		1
	6 Volt	5300-631-002	
	24 Volt	5300-631-003	
	90 Volt	5300-631-005	
5A-1	Terminal Accessory	5311-101-001	1
5B	Magnet - O.M. - Offset		1
	90 Volt	5300-631-014	
5B-1	Terminal Accessory	5311-101-001	1
5C	Magnet - O.M. - Flush		1
	6 Volt	5300-631-009	
	24 Volt	5300-631-010	
	90 Volt	5300-631-011	
5C-1	Terminal Accessory	5311-101-001	1
6	Conduit Box	5200-101-010	1

Item	Description	Part Number	Qty.
7	Bushing*		1
	1/2" to 1-1/4" Bore	180-0116 to 180-0128	

### How to Order:

1. Specify Bore Size for Item 7.
2. Specify Voltage for Item 5A, 5B, or 5C.
3. Specify Inside Mounted for Item 5A and Outside Mounted (Offset) for Item 5B or Outside Mounted (Flush) for Item 5C.
4. See Controls Section.

### Example:

PB-500 Brake per I-25544 - 90 Volt,  
Inside Mounted, 3/4" Bore

These units, when used in conjunction with the correct Warner Electric conduit box, meet the standards of UL508 and are listed under guide card #NMTR, file #59164. These units are CSA certified under file #LR11543.

\*See page 252 for specific part numbers.

Refer to Service Manual P-204.

# Brake

## PB-500 Heavy Duty

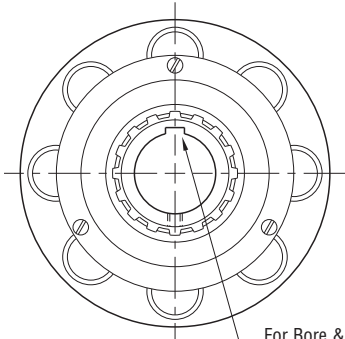

For Bore & Keyway sizes see chart below.

### ARMATURE VIEW

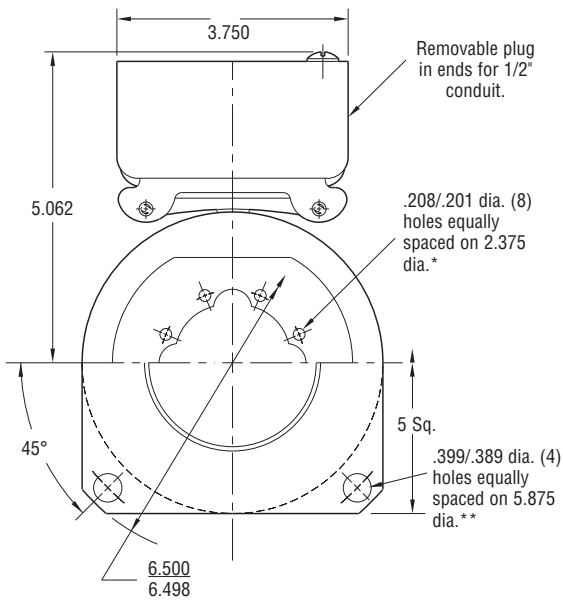

### MAGNET VIEW (Inside & Outside Mounted)

\* Mounting holes are within .010 of true position relative to pilot diameter.

\*\* Mounting holes are within .008 of true position relative to pilot diameter.

### Customer Shall Maintain:

1. Squareness of brake mounting face with armature hub shaft within .006 T.I.R.
2. Concentricity of brake mounting pilot diameter with armature hub shaft within .010 T.I.R.

### Outside Mounted Offset Backing Plate

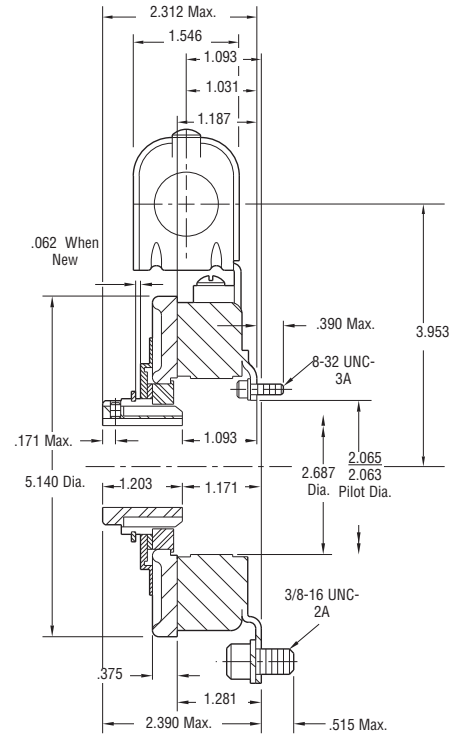

### Outside Mounted Flush Backing Plate

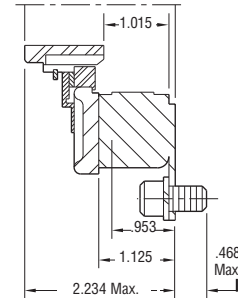

### Bore and Keyway Dimensions

Armature Bore Dia.	Keyway
.751/.750 .876/.875	.187 x .093
.9385/.9375 1.001/1.000 1.126/1.125 1.251/1.250	.250 x .125

Static Torque	40 lb. ft.
Maximum Speed	5,400 rpm
Standard Voltage	D.C. 6, 24, 90

All dimensions are nominal unless otherwise noted.

Information on inertia and weights begins on page 239. Coil data is on pages 250 and 251.



**PB-500 Heavy Duty**

**Drawing I-25550**

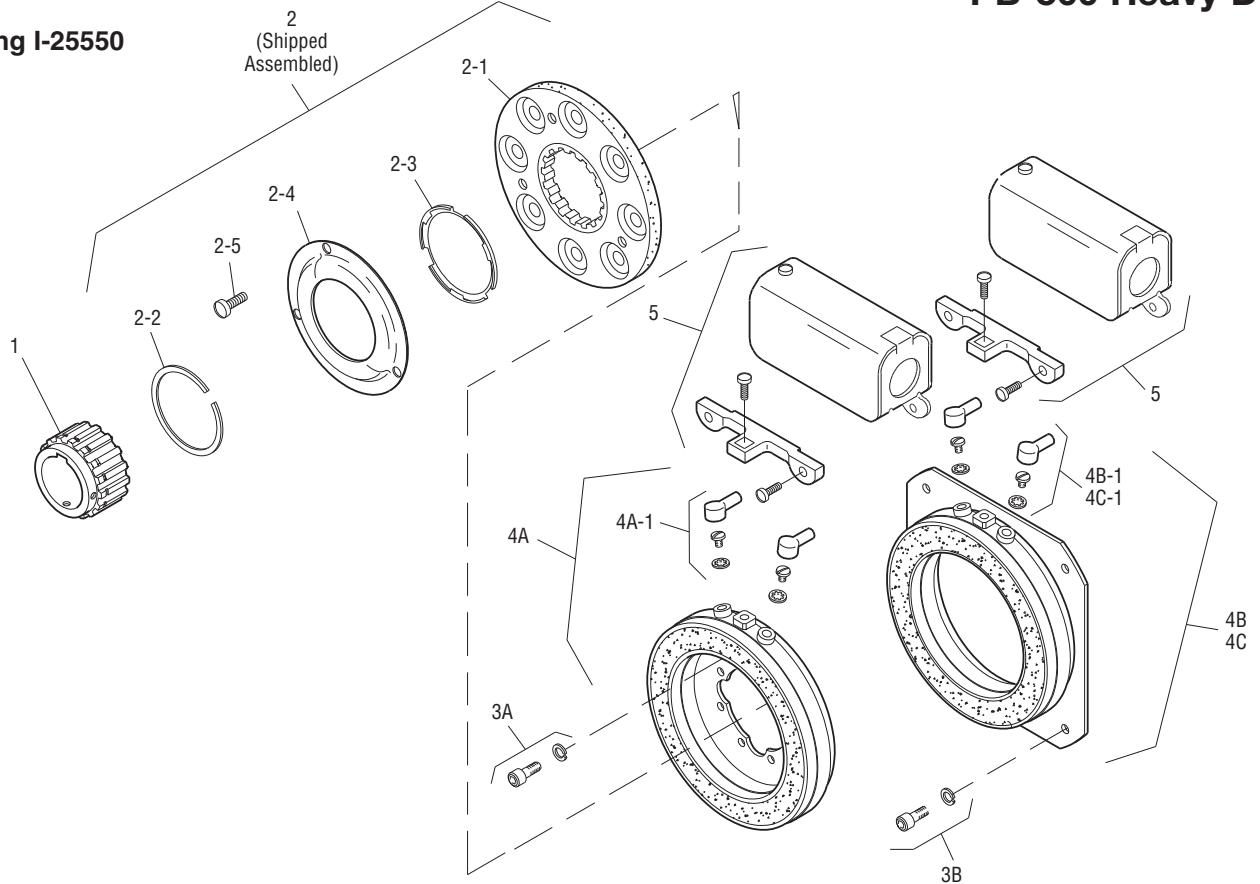

Item	Description	Part Number	Qty.
1	Armature Hub		1
	3/4" Bore	5200-541-002	
	7/8" Bore	5200-541-003	
	15/16" Bore	5200-541-004	
	1" Bore	5200-541-005	
	1-1/8" Bore	5200-541-006	
	1-1/4" Bore	5200-541-007	
2	Armature Assembly	5230-111-002	1
2-1	Armature		1
	Segmented	5230-111-001	
	Solid	110-0076	
2-2	Retainer Ring	748-0355	1
2-3	Autogap Spring	808-0412	1
2-4	Retainer Plate	748-0364	1
2-5	Screw	797-0028	3
3A	Mounting Accessory - I.M.	5102-101-001	2
3B	Mounting Accessory - O.M.	5300-101-008	1
4A	Magnet - I.M.		1
	6 Volt	5300-631-002	
	24 Volt	5300-631-003	
	90 Volt	5300-631-005	
4A-1	Terminal Accessory	5311-101-001	1
4B	Magnet - O.M. - Offset		1
	90 Volt	5300-631-014	

Item	Description	Part Number	Qty.
4B-1	Terminal Accessory	5311-101-001	1
4C	Magnet - O.M. - Flush		1
	6 Volt	5300-631-009	
	24 Volt	5300-631-010	
	90 Volt	5300-631-011	
4C-1	Terminal Accessory	5311-101-001	1
5	Conduit Box	5200-101-010	1

**How to Order:**

1. Specify Bore Size for Item 7.
2. Specify Voltage for Item 4A, 4B, or 4C.
3. Specify Inside Mounted for Item 4A and Outside Mounted (Offset) for Item 4B or Outside Mounted (Flush) for Item 4C.
4. See Controls Section.

**Example:**

PB-500 Brake per I-25550 - 90 Volt, Inside Mounted, 1" Bore

These units, when used in conjunction with the correct Warner Electric conduit box, meet the standards of UL508 and are listed under guide card #NMTR, file #59164. These units are CSA certified under file #LR11543.

Refer to Service Manual P-204.

# Brake

## PB-650

See page 252 for details on Bushings.

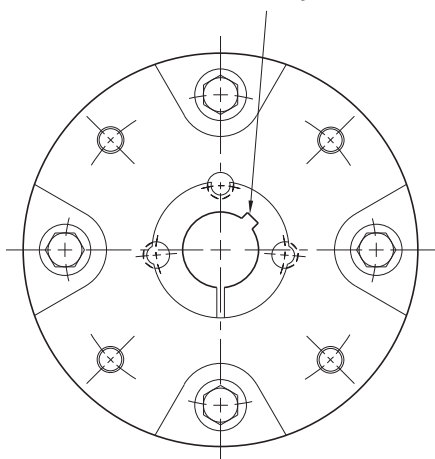

**HUB VIEW**

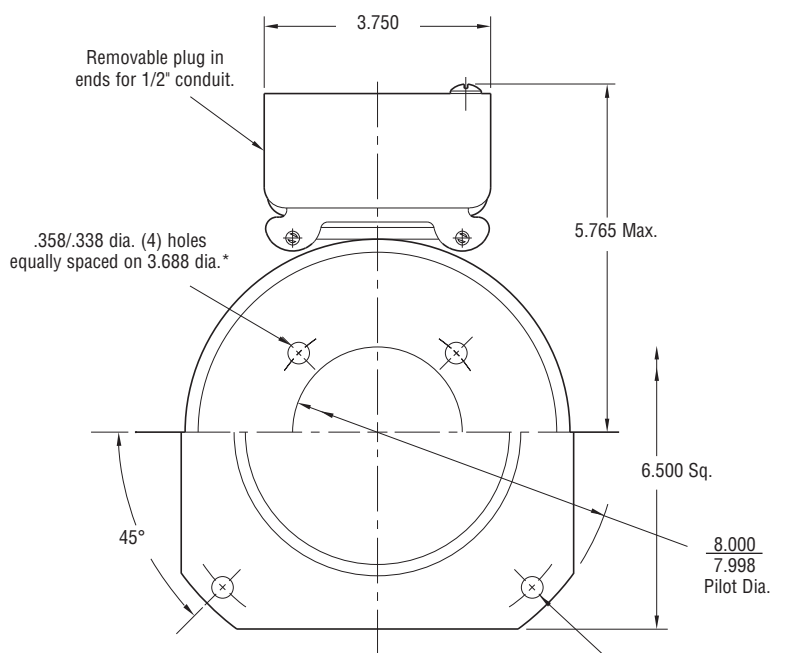

**MAGNET VIEW  
(Inside & Outside Mounted)**

\* Mounting holes are within .010 of true position relative to pilot diameter.

### Customer Shall Maintain:

1. Squareness of brake mounting face with armature hub shaft within .006 T.I.R.
2. Concentricity of brake mounting pilot diameter with armature hub shaft within .010 T.I.R.

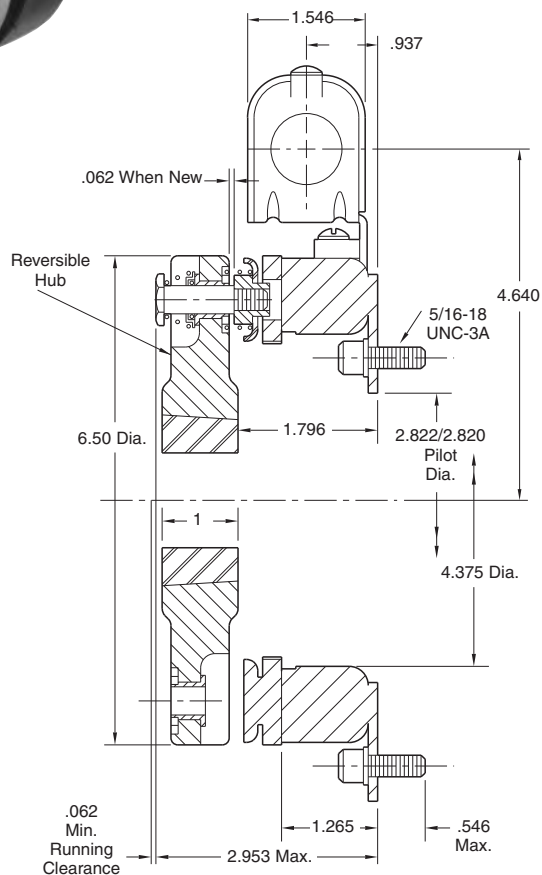

Shaft Sizes	.500 – 1.625
Static Torque	95 lb. ft.
Maximum Speed	3,600 rpm
Standard Voltage	D.C. 6, 24, 90

All dimensions are nominal unless otherwise noted.

Information on inertia and weights begins on page 239. Coil data is on pages 250 and 251.





**Drawing I-25730**

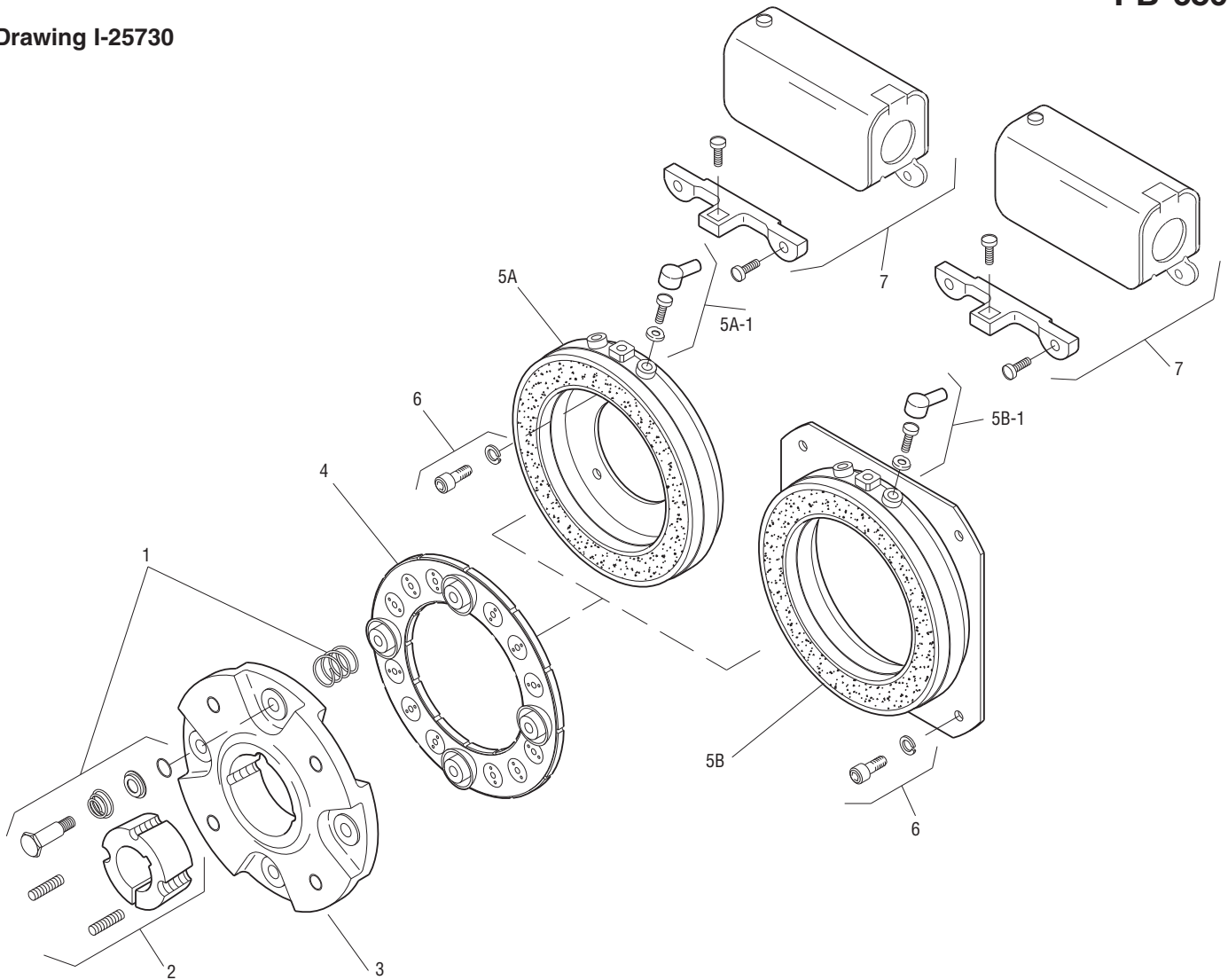

Item	Description	Part Number	Qty.
1	Autogap Accessory	5181-101-010	4
2	Bushing*		1
	1/2" to 1-5/8" Bore	180-0326 to 180-0344	
3	Armature Hub	5207-541-002	1
4	Armature	5281-111-002	1
5A	Magnet - Inside Mounted		1
	6 Volt	5369-631-003	
	24 Volt	5369-631-006	
	90 Volt	5369-631-005	
5A-1	Terminal Accessory	5311-101-001	1
5B	Magnet - Outside Mounted		1
	6 Volt	5369-631-009	
	24 Volt	5369-631-012	
	90 Volt	5369-631-011	
5B-1	Terminal Accessory	5311-101-001	1
6	Mounting Accessory	5321-101-002	1
7	Conduit Box	5200-101-010	1

**How to Order:**

1. Specify Bore Size for Item 2.
2. Specify Voltage for Item 5.
3. Specify Inside or Outside Mounted for Item 5.
4. See Controls Section.

**Example:**

PB-650 Brake per I-25730 - 90 Volt, 1" Bore

These units, when used in conjunction with the correct Warner Electric conduit box, meet the standards of UL508 and are listed under guide card #NMTR, file #59164. These units are CSA certified under file #LR11543.

\*See page 252 for specific part numbers.

Refer to Service Manual P-204.

# Brake

## PB-825 Normal Duty



See page 252 for details on Bushings.

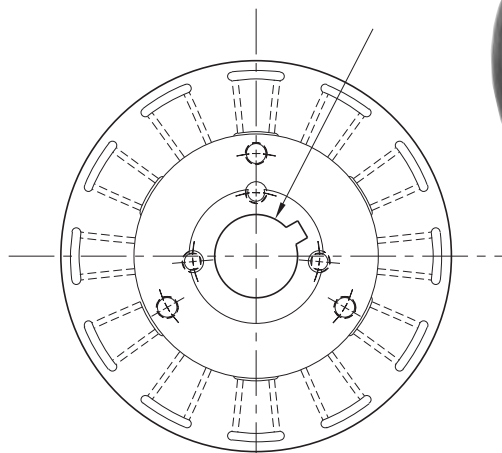

**ARMATURE VIEW**

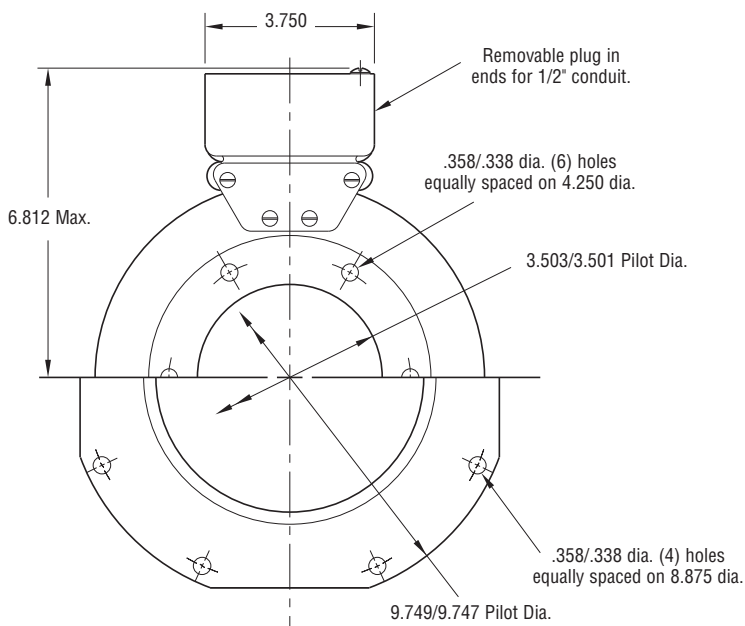

**MAGNET VIEW  
(Inside & Outside Mounted)**

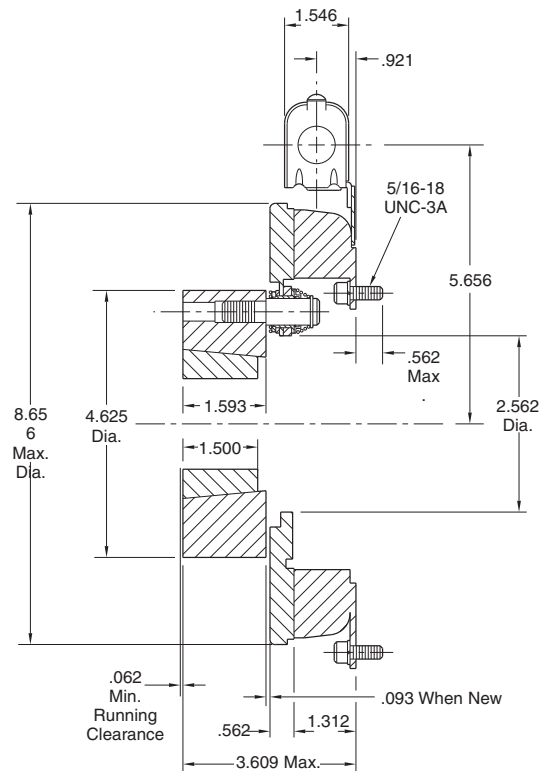

\* Mounting holes are within .010 of true positioning relative to pilot diameter.

Shaft Size	.500 – 1.625
Static Torque	125 lb. ft.
Maximum Speed	4,000 rpm
Standard Voltage	D.C. 6, 24, 90

All dimensions are nominal unless otherwise noted.

Information on inertia and weights begins on page 239. Coil data is on pages 250 and 251.

### Customer Shall Maintain:

1. Squareness of magnet mounting face with armature shaft within .006 T.I.R.
2. Concentricity of magnet mounting pilot diameter with armature shaft within .010 T.I.R.



**Drawing I-25566**

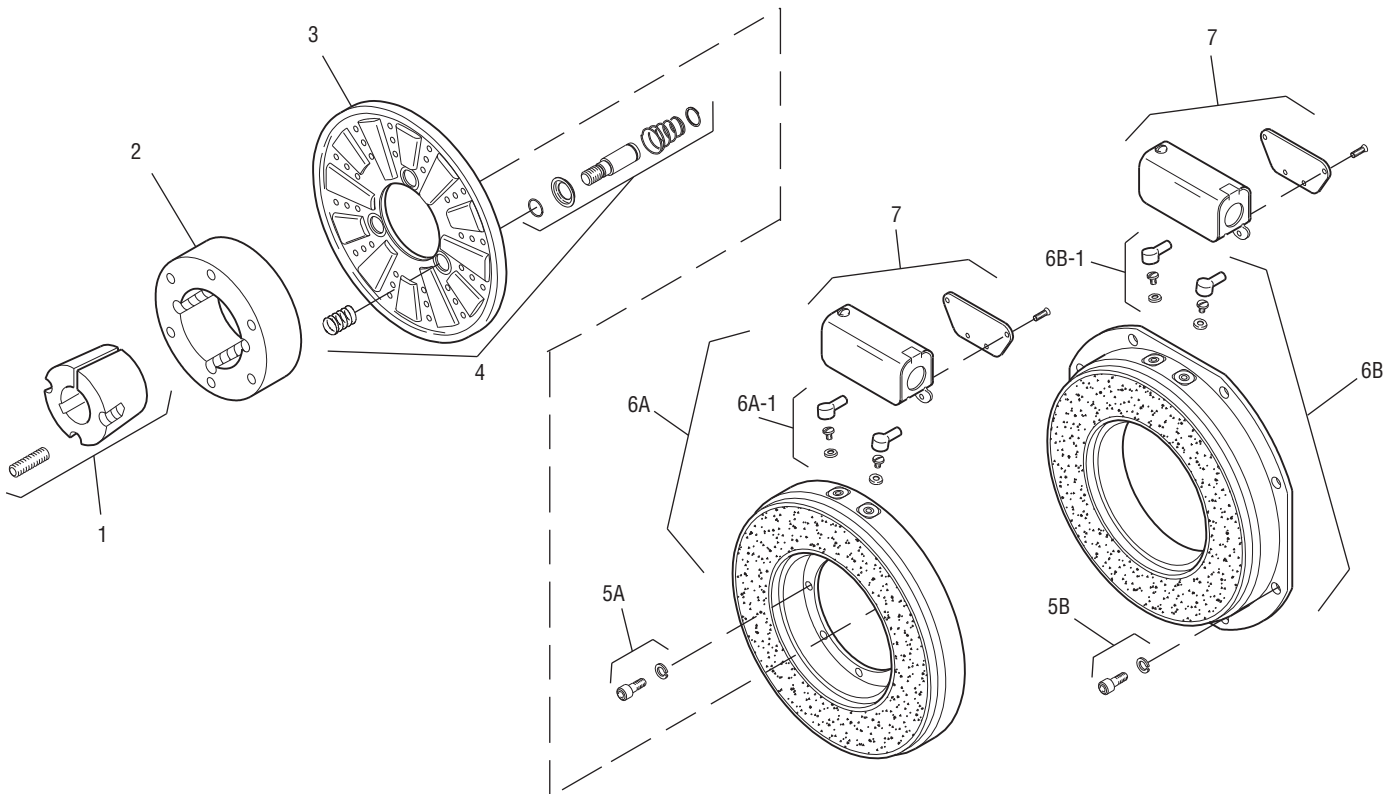

Item	Description	Part Number	Qty.
1	Bushing*		1
	1/2" to 1-5/8" Bore	180-0131 to 180-0149	
2	Armature Hub	540-0394	1
3	Armature	5301-111-018	1
4	Autogap Accessory	5201-101-008	3
5A	Mounting Accessory - I.M.	5321-101-001	1
5B	Mounting Accessory - O.M.	5321-101-002	1
6A	Magnet - Inside Mounted		1
	6 Volt	5311-631-002	
	24 Volt	5311-631-003	
	90 Volt	5311-631-004	
	†90 Volt LK Facing	5311-631-011	
6A-1	Terminal Accessory	5311-101-001	1
6B	Magnet, Outside Mounted		1
	6 Volt	5311-631-007	
	24 Volt	5311-631-009	
	90 Volt	5311-631-008	
	†90 Volt LK Facing	5311-631-012	

Item	Description	Part Number	Qty.
6B-1	Terminal Accessory	5311-101-001	1
7	Conduit Box	5200-101-011	1

**How to Order:**

1. Specify Bore Size for Item 1.
2. Specify Inside Mounted for Items 5A and 6A or Outside Mounted for Items 5B and 6B.
3. Specify Voltage for Item 6A or 6B.
4. See Controls Section.

**Example:**

PB-825 Brake per I-25566 - 90 Volt, Inside Mounted, 1" Bore

These units, when used in conjunction with the correct Warner Electric conduit box, meet the standards of UL508 and are listed under guide card #NMTR, file #59164. These units are CSA certified under file #LR11543.

\*See page 252 for specific part numbers.

Refer to Service Manual P-208.

†Optional LK facing available. For more information, see page 232.

# Brake

## PB-825 Heavy Duty

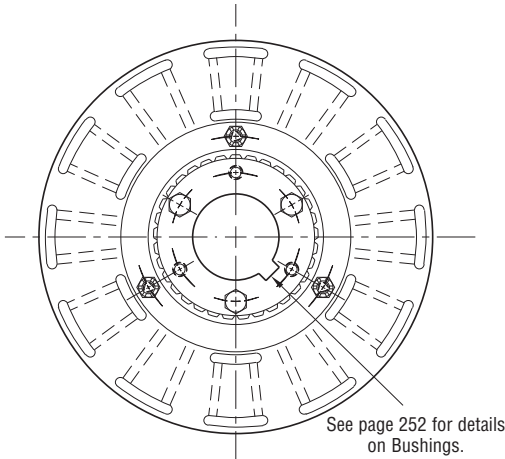

**ARMATURE VIEW**

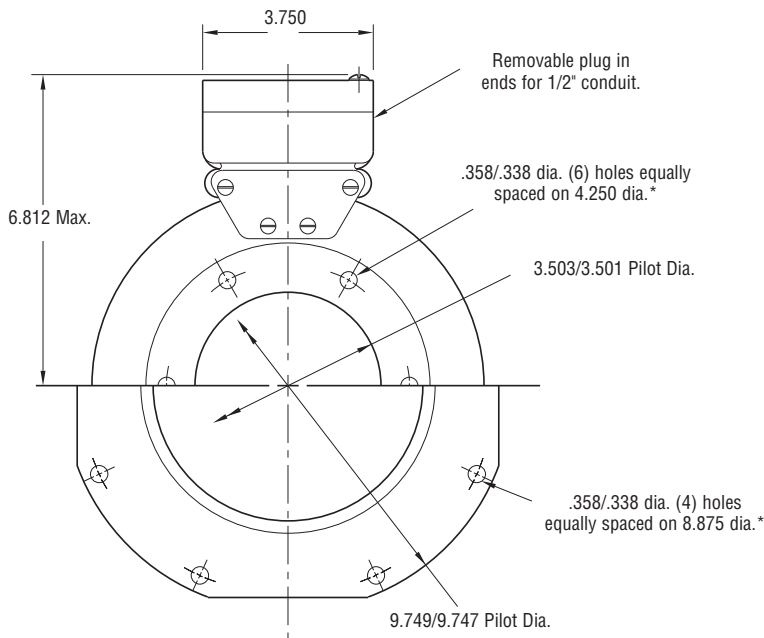
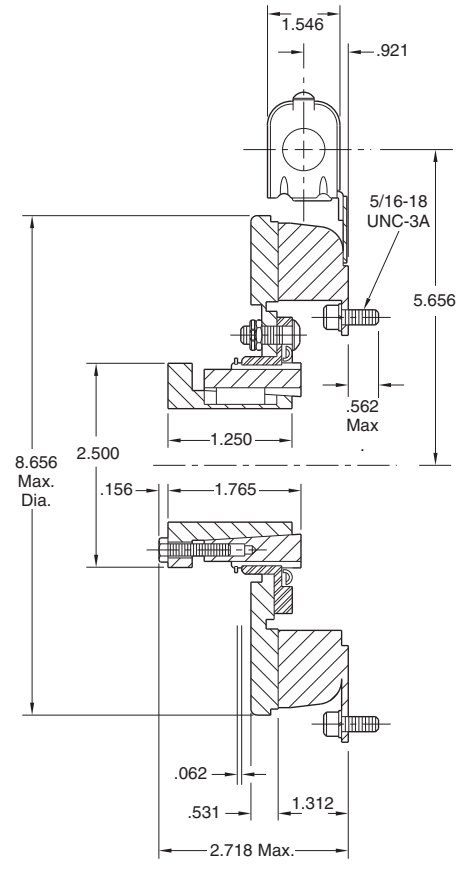

**MAGNET VIEW  
(Inside & Outside Mounted)**

\* Mounting holes are within .010 of true position relative to pilot diameter.

### Customer Shall Maintain:

1. Squareness of magnet mounting face with armature shaft within .006 T.I.R.
2. Concentricity of magnet mounting pilot diameter with armature shaft within .010 T.I.R.



Shaft Size	.500 – 1.500
Static Torque	125 lb. ft.
Maximum Speed	4,000 rpm
Standard Voltage	D.C. 6, 24, 90

All dimensions are nominal unless otherwise noted.

Information on inertia and weights begins on page 239. Coil data is on pages 250 and 251.

Drawing I-25567

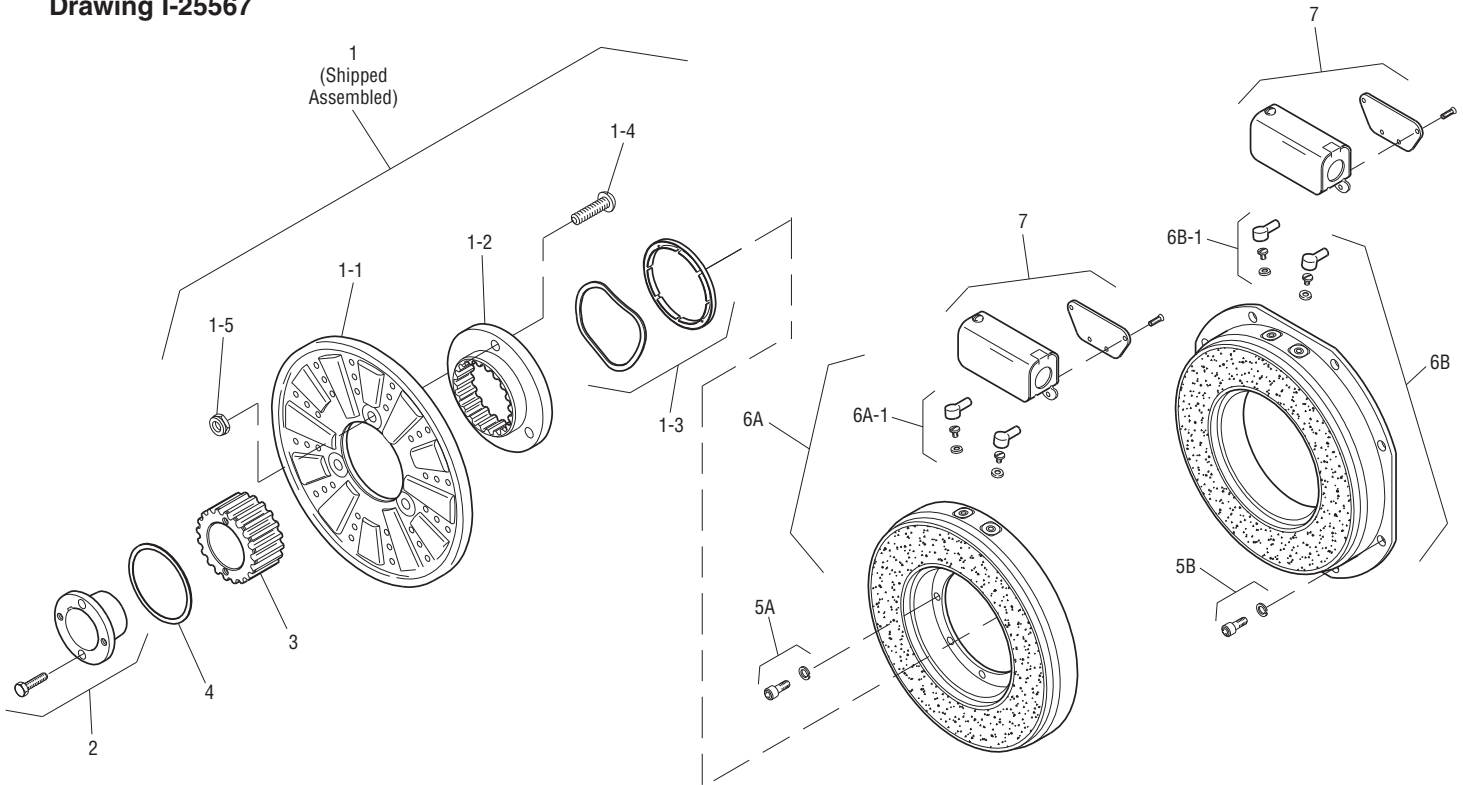

Item	Description	Part Number	Qty.
1	Armature Assembly	5321-111-001	1
1-1	Armature	5321-111-022	1
1-2	Splined Adapter	104-0008	1
1-3	Autogap Accessory	5321-101-006	1
1-4	Screw	797-0272	3
1-5	Locknut	661-0004	3
2	Bushing*		1
	1/2" to 1-1/2" Bore	180-0002 to 180-0018	
3	Splined Hub	540-0057	1
4	Retainer Ring	748-0006	1
5A	Mounting Accessory - I.M.	5321-101-001	1
5B	Mounting Accessory - O.M.	5321-101-002	1
6A	Magnet - Inside Mounted		1
	6 Volt	5311-631-002	
	24 Volt	5311-631-003	
	90 Volt	5311-631-004	
	†90 Volt LK Facing	5311-631-011	
6A-1	Terminal Accessory	5311-101-001	1
6B	Magnet - Outside Mounted		1
	6 Volt	5311-631-007	
	24 Volt	5311-631-009	
	90 Volt	5311-631-008	
	†90 Volt LK Facing	5311-631-012	

Item	Description	Part Number	Qty.
6B-1	Terminal Accessory	5311-101-001	1
7	Conduit Box	5200-101-011	1

### How to Order:

1. Specify Bore Size for Item 2.
2. Specify Inside Mounted for Items 5A and 6A or Outside Mounted for Items 5B and 6B.
3. Specify Voltage for Item 6A or 6B.
4. See Controls Section.

### Example:

PB-825 Brake per I-25567 - 90 Volt, 1" Bore, Inside Mounted

These units, when used in conjunction with the correct Warner Electric conduit box, meet the standards of UL508 and are listed under guide card #NMTR, file #59164. These units are CSA certified under file #LR11543.

\*See page 252 for specific part numbers.

Refer to Service Manual P-209.

†Optional LK facing available. For more information, see page 232.

# Brake

## PB-1000 Normal Duty



See page 252 for details on Bushings.

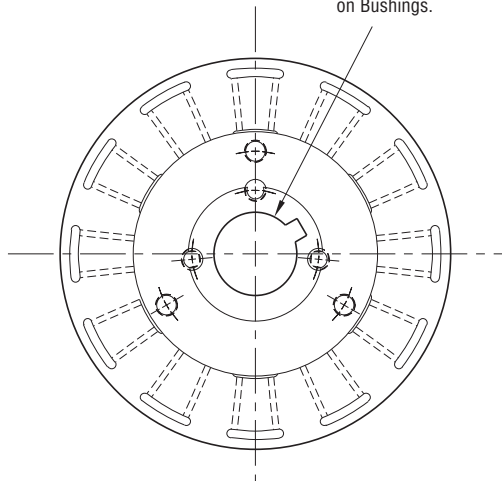

**ARMATURE VIEW**

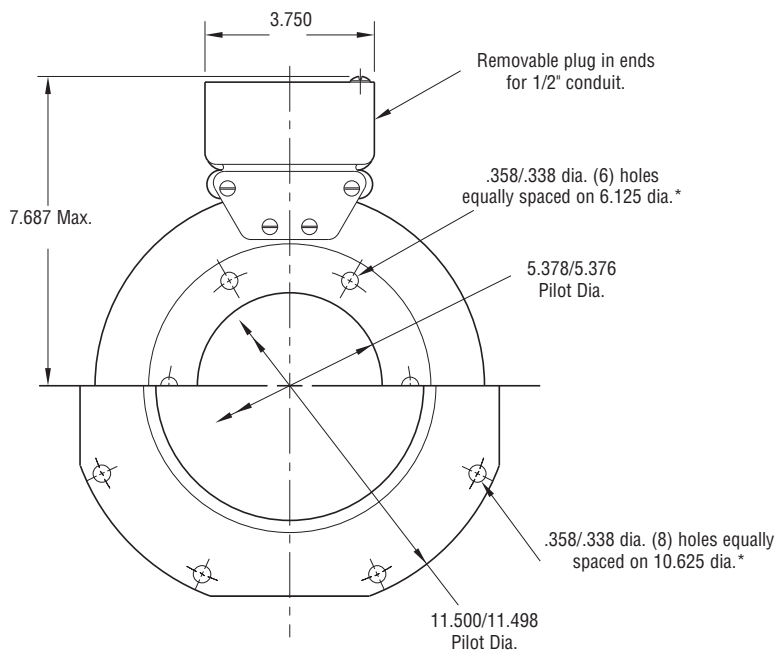

**MAGNET VIEW  
(Inside & Outside Mounted)**

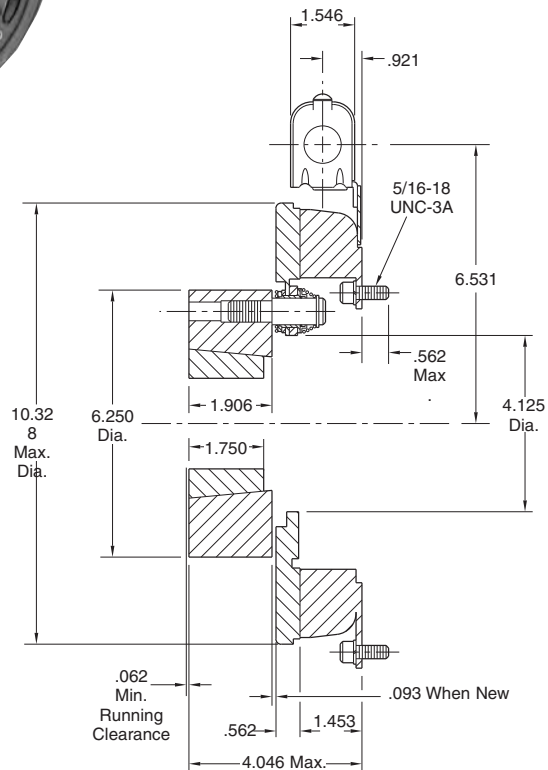

\* Mounting holes are within .010 of true position relative to pilot diameter.

Shaft Size	.500 – 2.500
Static Torque	240 lb. ft.
Maximum Speed	3,600 rpm
Standard Voltage	D.C. 6, 24, 90

All dimensions are nominal unless otherwise noted.

Information on inertia and weights begins on page 239. Coil data is on pages 250 and 251.

### Customer Shall Maintain:

1. Squareness of magnet mounting face with armature shaft within .006 T.I.R.
2. Concentricity of magnet mounting pilot diameter with armature shaft within .010 T.I.R.



**Drawing I-25586**

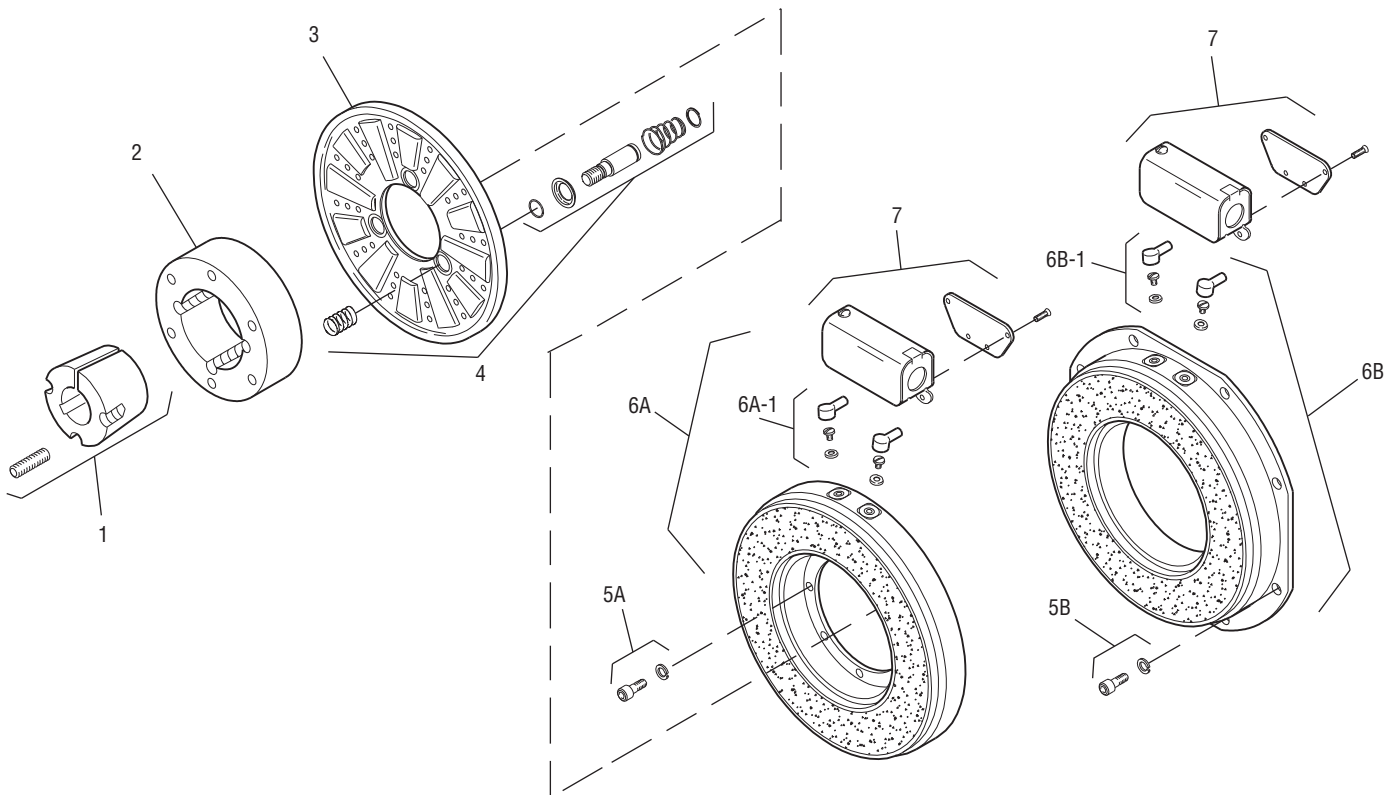

Item	Description	Part Number	Qty.
1	Bushing*		1
	1/2" to 2-1/2" Bore	180-0185 to 180-0217	
2	Armature Hub	540-0313	1
3	Armature	5302-111-013	1
4	Autogap Accessory	5201-101-008	3
5A	Mounting Accessory - I.M.	5321-101-001	1
5B	Mounting Accessory - O.M.	5321-101-002	2
6A	Magnet - Inside Mounted		1
	6 Volt	5312-631-004	
	24 Volt	5312-631-005	
	90 Volt	5312-631-006	
	†90 Volt LK Facing	5312-631-001	
6A-1	Terminal Accessory	5311-101-001	1
6B	Magnet, Outside Mounted		1
	6 Volt	5312-631-011	
	24 Volt	5312-631-013	
	90 Volt	5312-631-012	
	†90 Volt LK Facing	5312-631-002	

Item	Description	Part Number	Qty.
6B-1	Terminal Accessory	5311-101-001	1
7	Conduit Box	5200-101-011	1

**How to Order:**

1. Specify Bore Size for Item 1.
2. Specify Inside Mounted for Items 5A and 6A or Outside Mounted for Items 5B and 6B.
3. Specify Voltage for Item 6A or 6B.
4. See Controls Section.

**Example:**

PB-1000 Brake per I-25586 - 90 Volt, Inside Mounted, 1" Bore

These units, when used in conjunction with the correct Warner Electric conduit box, meet the standards of UL508 and are listed under guide card #NMTR, file #59164. These units are CSA certified under file #LR11543.

\*See page 252 for specific part numbers.

Refer to Service Manual P-208.

†Optional LK facing available. For more information, see page 232.

# Brake

## PB-1000 Heavy Duty

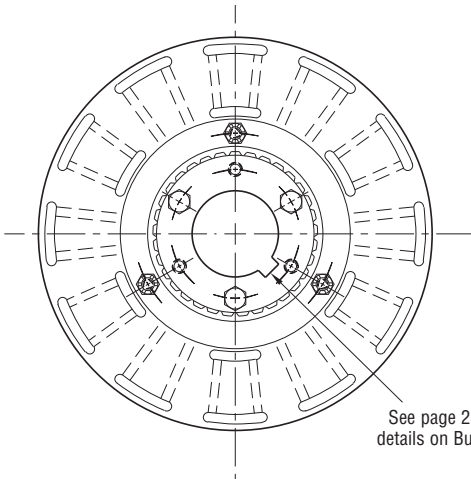

See page 252 for details on Bushings.

### ARMATURE VIEW

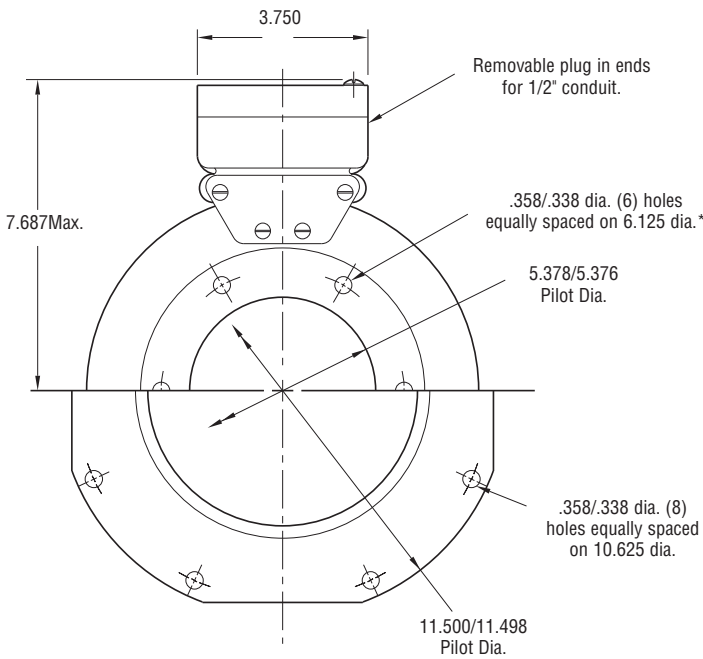

### MAGNET VIEW (Inside & Outside Mounted)

\* Mounting holes are within .010 of true position relative to pilot diameter.

#### Customer Shall Maintain:

1. Squareness of magnet mounting face with armature shaft within .006 T.I.R.
2. Concentricity of magnet mounting pilot diameter with armature shaft within .010 T.I.R.

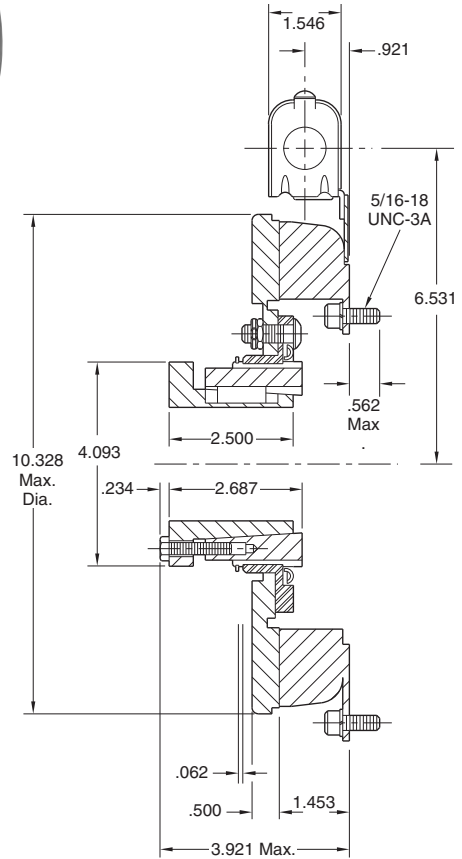

Shaft Size	.750 – 2.687
Static Torque	240 lb. ft.
Maximum Speed	3,600 rpm
Standard Voltage	D.C. 6, 24, 90

All dimensions are nominal unless otherwise noted.

Information on inertia and weights begins on page 239. Coil data is on pages 250 and 251.





Drawing I-25587

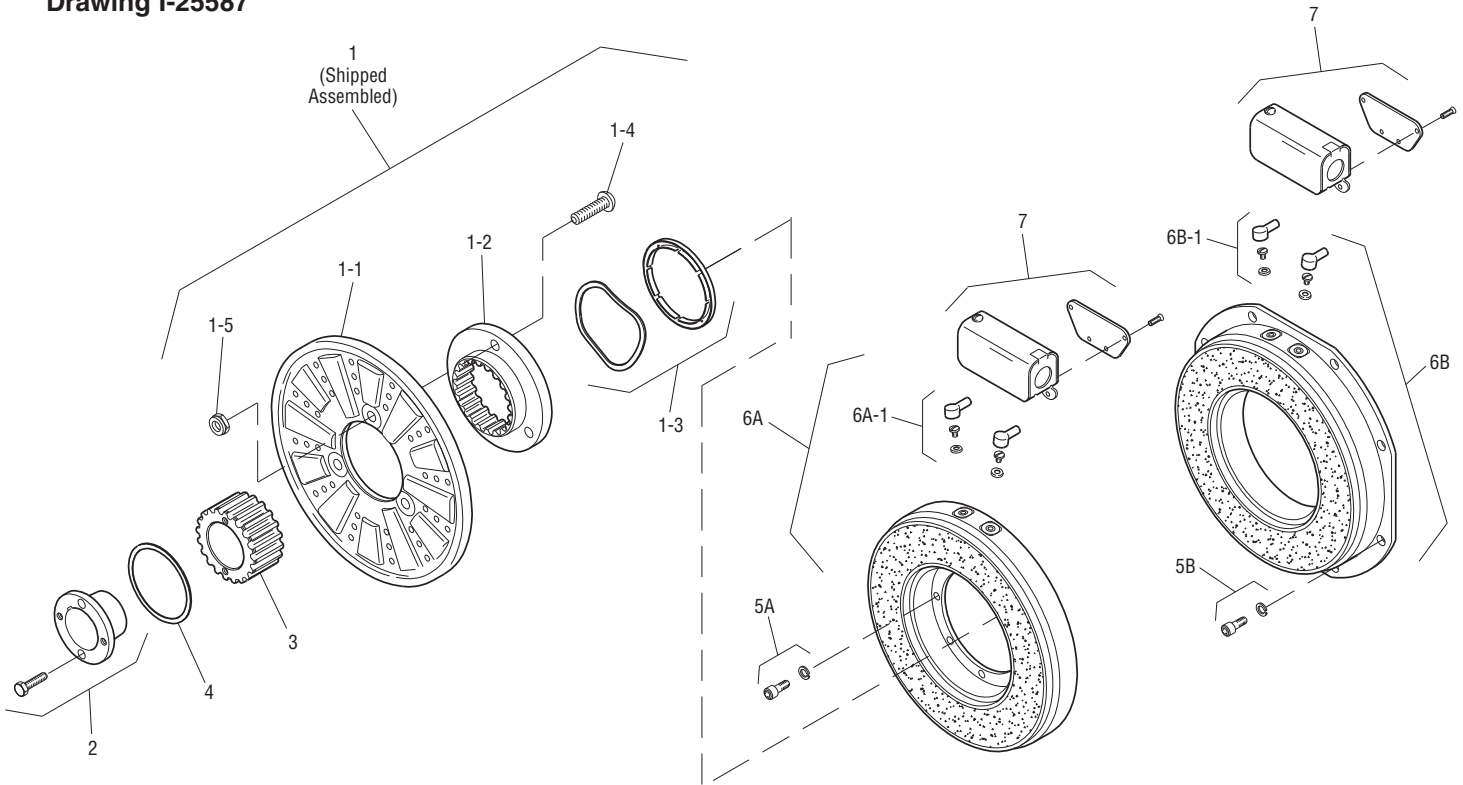

Item	Description	Part Number	Qty.
1	Armature Assembly	5322-111-002	1
1-1	Armature	5322-111-036	1
1-2	Splined Adapter	104-0009	1
1-3	Autogap Accessory	5322-101-004	1
1-4	Screw	797-0272	3
1-5	Locknut	661-0004	3
2	Bushing*		1
	3/4" to 2-11/16" Bore	180-0026 to 180-0057	
3	Splined Hub	540-0062	1
4	Retainer Ring	748-0007	1
5A	Mounting Accessory - I.M.	5321-101-001	1
5B	Mounting Accessory - O.M.	5321-101-002	2
6A	Magnet - Inside Mounted		1
	6 Volt	5312-631-004	
	24 Volt	5312-631-005	
	90 Volt	5312-631-006	
	†90 Volt LK Facing	5312-631-001	
6A-1	Terminal Accessory	5311-101-001	1
6B	Magnet - Outside Mounted		1
	6 Volt	5312-631-011	
	24 Volt	5312-631-013	
	90 Volt	5312-631-012	
	†90 Volt LK Facing	5312-631-002	

Item	Description	Part Number	Qty.
6B-1	Terminal Accessory	5311-101-001	1
7	Conduit Box	5200-101-011	1

### How to Order:

1. Specify Bore Size for Item 2.
2. Specify Inside Mounted for Items 5A and 6A or Outside Mounted for Items 5B and 6B.
3. Specify Voltage for Item 6A or 6B.
4. See Controls Section.

### Example:

PB-1000 Brake per I-25587 - 90 Volt, 1-1/2" Bore, Inside Mounted

These units, when used in conjunction with the correct Warner Electric conduit box, meet the standards of UL508 and are listed under guide card #NMTR, file #59164. These units are CSA certified under file #LR11543.

\*See page 252 for specific part numbers.

Refer to Service Manual P-209.

†Optional LK facing available. For more information, see page 232.

# Brake

## PB-1225 Normal Duty



See page 252 for details on Bushings.

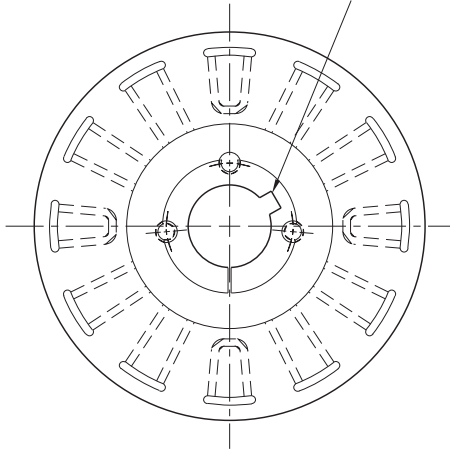

**ARMATURE VIEW**

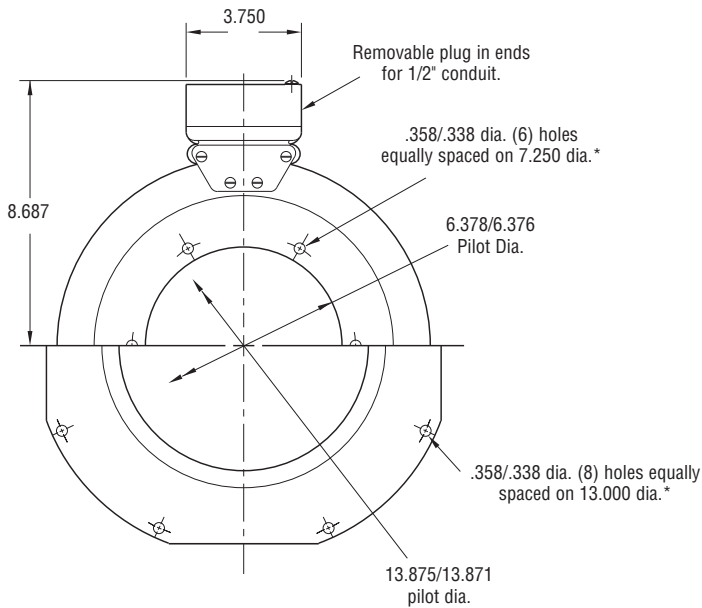

**MAGNET VIEW  
(Inside & Outside Mounted)**

\* Mounting holes are within .010 of true position relative to pilot diameter.

### Customer Shall Maintain:

1. Squareness of magnet mounting face with armature shaft within .006 T.I.R.
2. Concentricity of magnet mounting pilot diameter with armature shaft within .010 T.I.R.

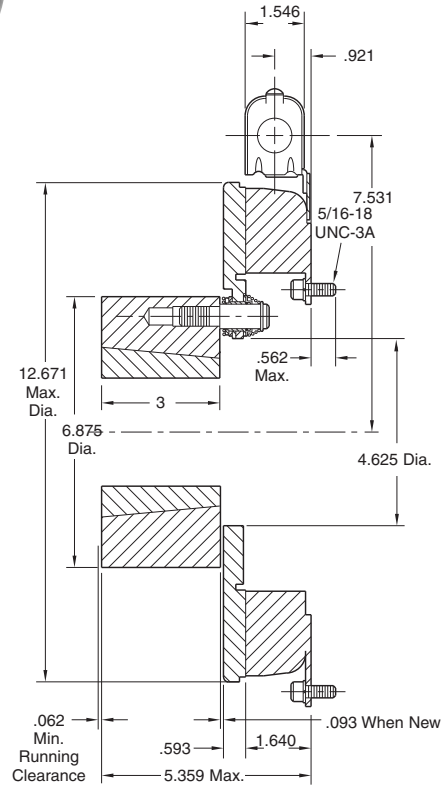

Shaft Size	.937 – 3.000
Static Torque	465 lb. ft.
Maximum Speed	3,000 rpm
Standard Voltage	D.C. 6, 24, 90

All dimensions are nominal unless otherwise noted.

Information on inertia and weights begins on page 239. Coil data is on pages 250 and 251.



**PB-1225 Normal Duty**

**Drawing I-25606**

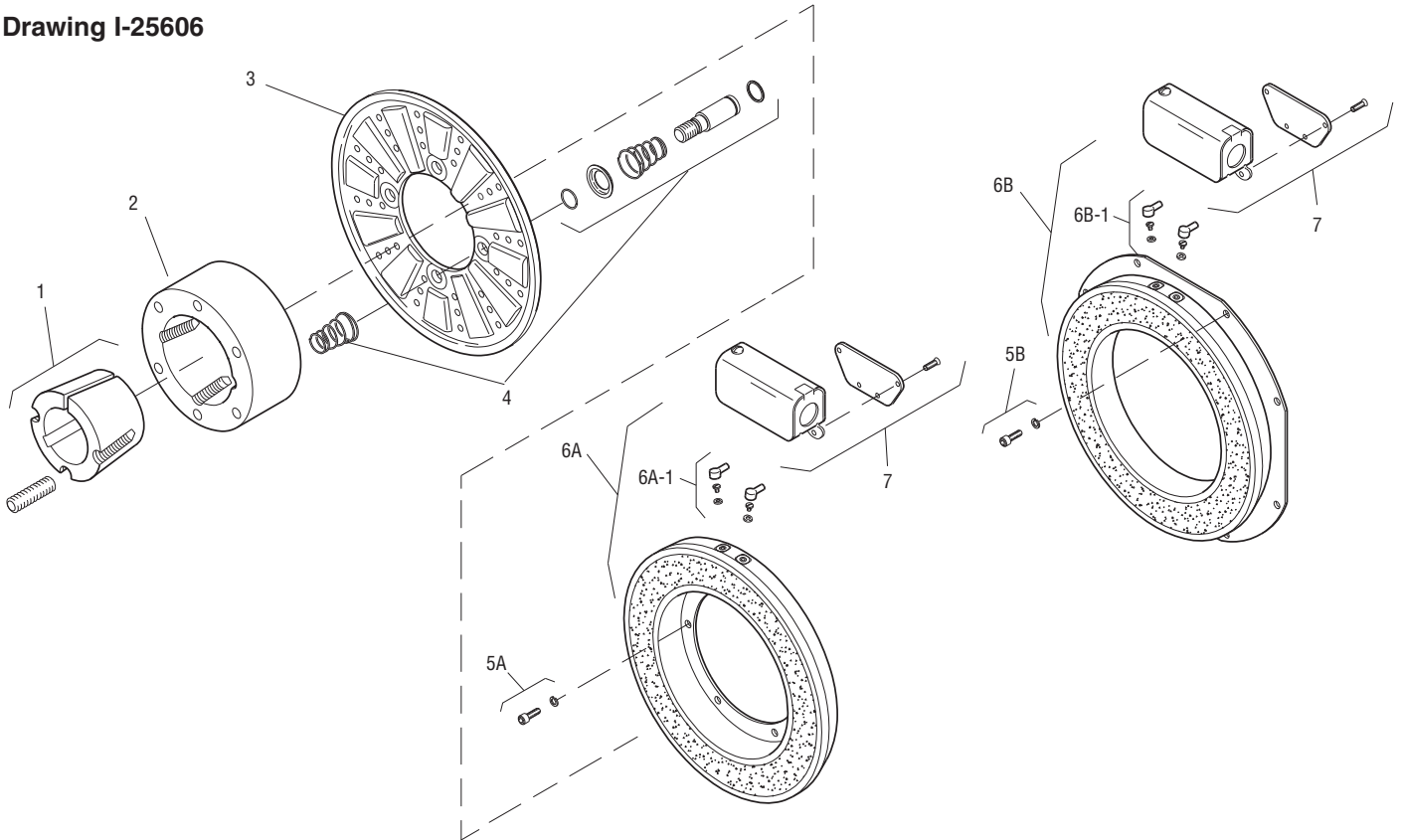

Item	Description	Part Number	Qty.
1	Bushing*		1
	15/16" to 3" Bore	180-0262 to 180-0295	
2	Armature Hub	540-0015	1
3	Armature	5303-111-009	1
4	Autogap Accessory	5201-101-008	4
5A	Mounting Accessory - I.M.	5321-101-001	1
5B	Mounting Accessory - O.M.	5321-101-002	2
6A	Magnet - Inside Mounted		1
	6 Volt	5313-631-005	
	24 Volt	5313-631-006	
	90 Volt	5313-631-007	
	†90 Volt	5313-631-001	
6A-1	Terminal Accessory	5311-101-001	1
6B	Magnet - Outside Mounted		1
	6 Volt	5313-631-010	
	24 Volt	5313-631-012	
	90 Volt	5313-631-011	
	†90 Volt	5313-631-002	

Item	Description	Part Number	Qty.
6B-1	Terminal Accessory	5311-101-001	1
7	Conduit Box	5200-101-011	1

**How to Order:**

1. Specify Bore Size for Item 1.
2. Specify Inside Mounted for Items 5A and 6A or Outside Mounted for Items 5B and 6B.
3. Specify Voltage for Item 6A or 6B.
4. See Controls Section.

**Example:**

PB-1225 Brake per I-25606 - 90 Volt, 1" Bore, Inside Mounted

These units, when used in conjunction with the correct Warner Electric conduit box, meet the standards of UL508 and are listed under guide card #NMTR, file #59164. These units are CSA certified under file #LR11543.

\*See page 252 for specific part numbers.

Refer to Service Manual P-208.

†Optional LK facing available. For more information, see page 232.

# Brake

## PB-1225 Heavy Duty

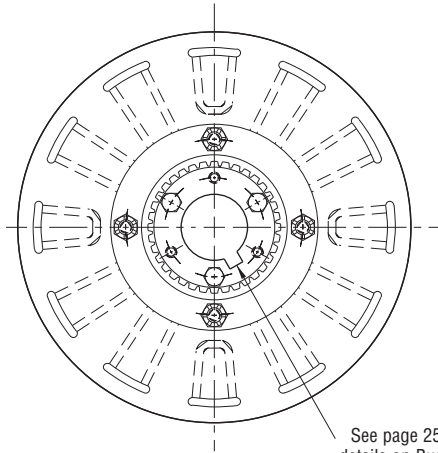

See page 252 for details on Bushings.

**ARMATURE VIEW**

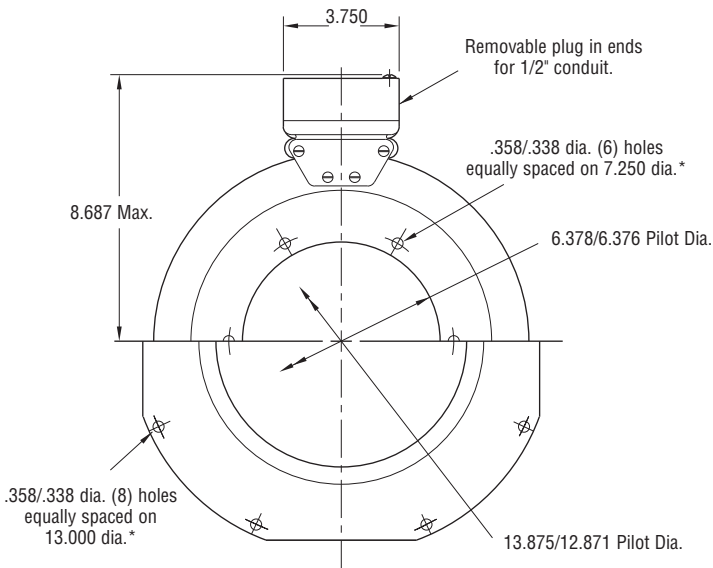

**MAGNET VIEW**

\* Mounting holes are within .010 of true position relative to pilot diameter.

**Customer Shall Maintain:**

1. Squareness of magnet mounting face with armature shaft within .006 T.I.R.
2. Concentricity of magnet mounting pilot diameter with armature shaft within .010 T.I.R.

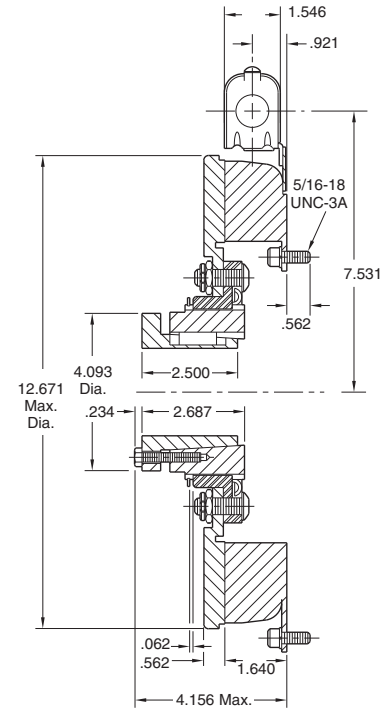

Shaft Size	.750 – 2.687
Static Torque	465 lb. ft.
Maximum Speed	3,000 rpm
Standard Voltage	D.C. 6, 24, 90

All dimensions are nominal unless otherwise noted.

Information on inertia and weights begins on page 239. Coil data is on pages 250 and 251.



**Drawing I-25607**

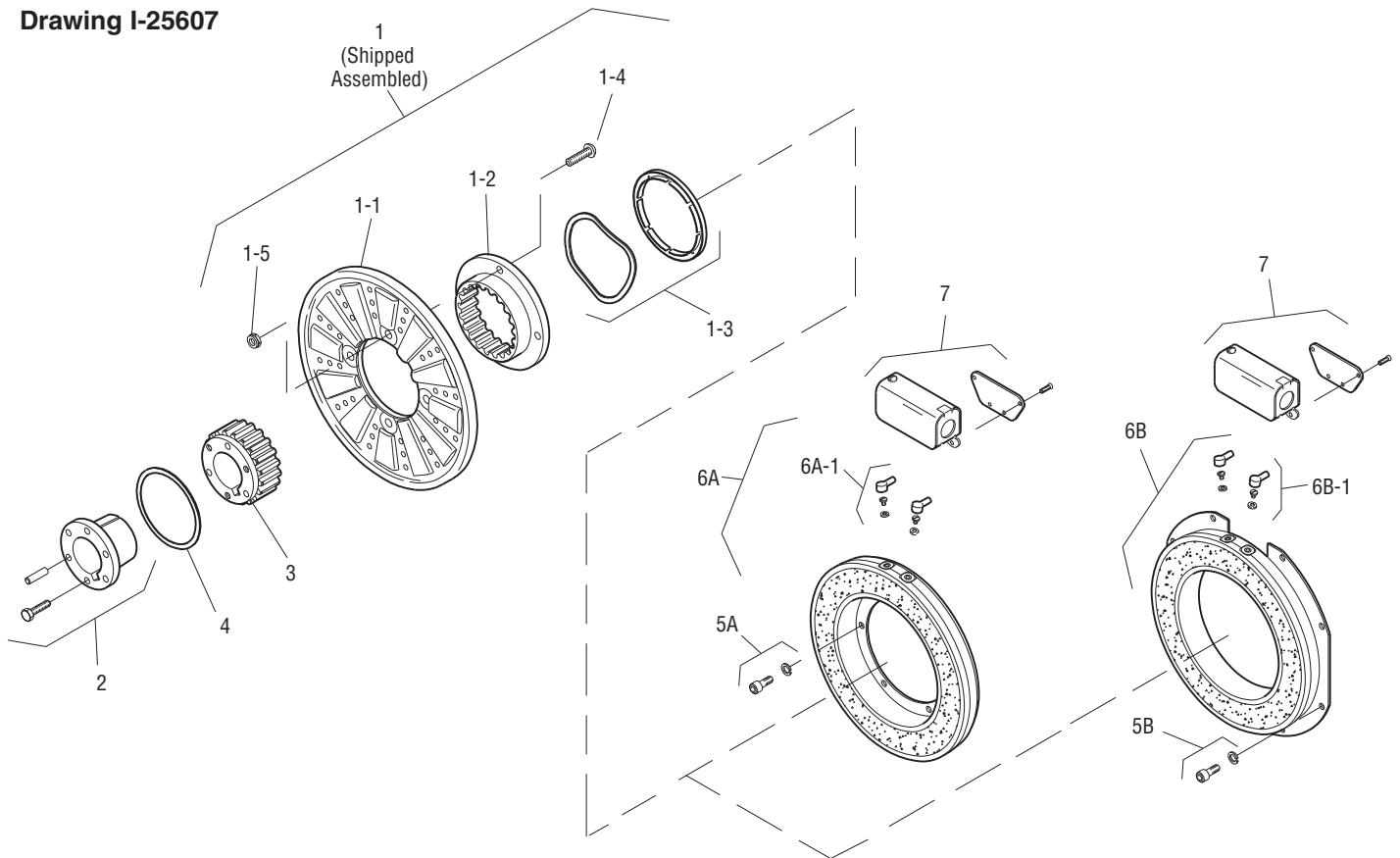

Item	Description	Part Number	Qty.
1	Armature & Splined Adapter	5323-111-001	1
1-1	Armature	5323-111-034	1
1-2	Splined Adapter	104-0010	1
1-3	Autogap Accessory	5323-101-002	1
1-4	Screw	797-0281	4
1-5	Locknut	661-0005	4
2	Bushing*		1
	3/4" to 2-11/16" Bore	180-0026 to 180-0057	
3	Splined Hub	540-0064	1
4	Retainer Ring	748-0005	1
5A	Mounting Accessory - I.M.	5321-101-001	1
5B	Mounting Accessory - O.M.	5321-101-002	2
6A	Magnet - Inside Mounted		1
	6 Volt	5313-631-005	
	24 Volt	5313-631-006	
	90 Volt	5313-631-007	
	†90 Volt	5313-631-001	
6A-1	Terminal Accessory	5311-101-001	1
6B	Magnet - Outside Mounted		1
	6 Volt	5313-631-010	
	24 Volt	5313-631-012	
	90 Volt	5313-631-011	
	†90 Volt	5313-631-002	

Item	Description	Part Number	Qty.
6B-1	Terminal Accessory	5311-101-001	1
7	Conduit Box	5200-101-011	1

**How to Order:**

1. Specify Bore Size for Item 2.
2. Specify Inside Mounted for Items 5A and 6A or Outside Mounted for Items 5B and 6B.
3. Specify Voltage for Item 6A or 6B.
4. See Controls Section.

**Example:**

PB-1225 Clutch per I-25607 - 90 Volt, 1-1/2" Bore, Inside Mounted

These units, when used in conjunction with the correct Warner Electric conduit box, meet the standards of UL508 and are listed under guide card #NMTR, file #59164. These units are CSA certified under file #LR11543.

\*See page 252 for specific part numbers.

Refer to Service Manual P-209.

†Optional LK facing available. For more information, see page 232.

# Brake

## PB-1525 Normal Duty



See page 252 for details on Bushings.

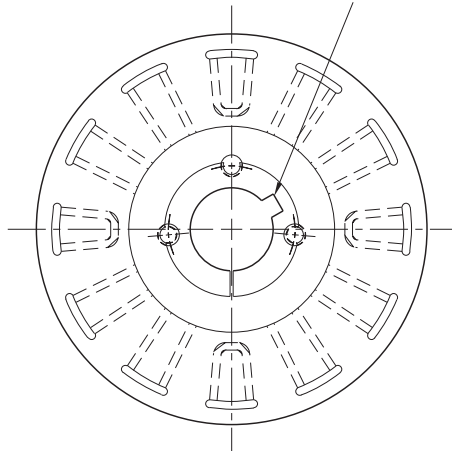

**ARMATURE VIEW**

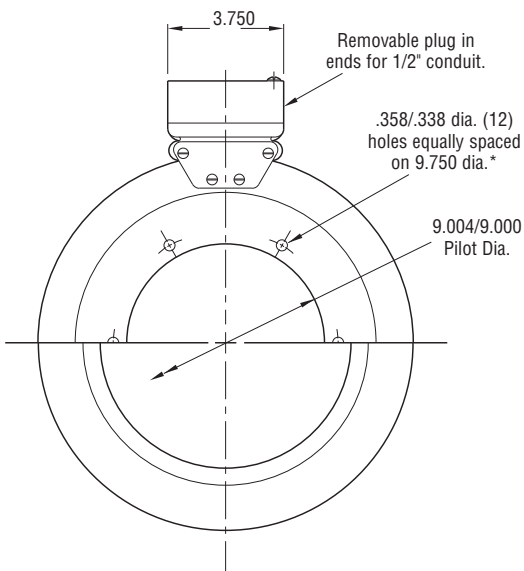

**MAGNET VIEW  
(Inside & Outside Mounted)**

\* Mounting holes are within .010 of true position relative to pilot diameter.

### Customer Shall Maintain:

1. Squareness of magnet mounting face with armature shaft within .006 T.I.R.
2. Concentricity of magnet mounting pilot diameter with armature shaft within .010 T.I.R.

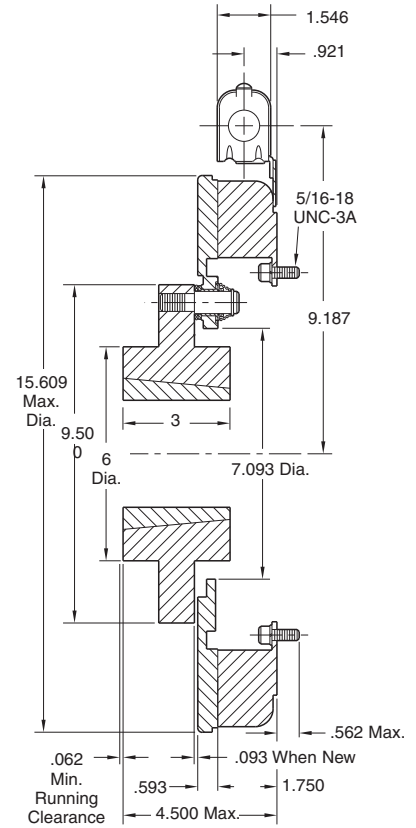

Shaft Size	.937 – 3.000
Static Torque	700 lb. ft.
Maximum Speed	2,000 rpm
Standard Voltage	D.C. 6, 24, 90

All dimensions are nominal unless otherwise noted.

Information on inertia and weights begins on page 239. Coil data is on pages 250 and 251.



**PB-1525 Normal Duty**

**Drawing I-25633**

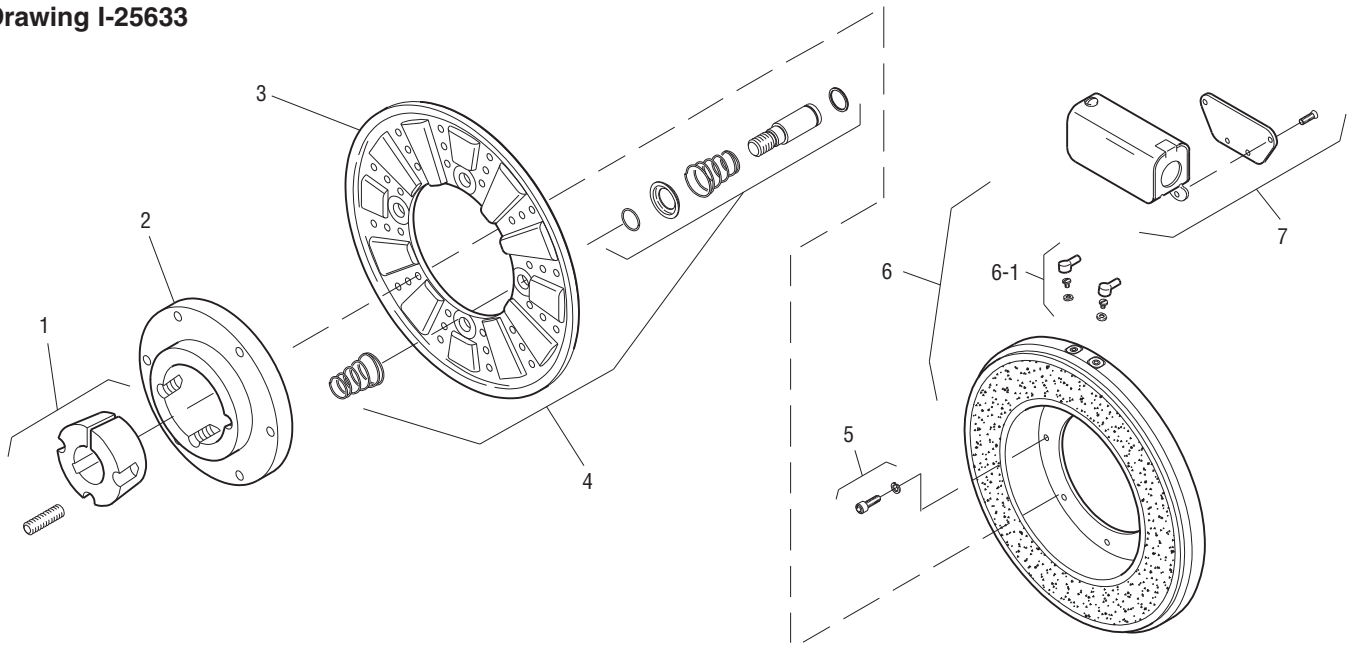

Item	Description	Part Number	Qty.
1	Bushing*		1
	15/16" to 3" Bore	180-0262 to 180-0295	
2	Armature Hub	540-0314	1
3	Armature	5304-111-004	1
4	Autogap Accessory	5201-101-008	4
5	Mounting Accessory - I.M.	5321-101-001	2
6	Magnet - Inside Mounted		1
	6 Volt	5314-631-004	
	24 Volt	5314-631-006	
	90 Volt	5314-631-005	
	†90 Volt	5314-631-001	
6-1	Terminal Accessory	5311-101-001	1
7	Conduit Box	5200-101-011	1

**How to Order:**

1. Specify Bore Size for Item 1.
2. Specify Inside Mounted for Items 5 and 6.
3. Specify Voltage for Item 6.
4. See Controls Section.

**Example:**

PB-1525 Brake per I-25633 - 90 Volt,  
1-1/2" Bore, Inside Mounted

These units, when used in conjunction with the correct Warner Electric conduit box, meet the standards of UL508 and are listed under guide card #NMTR, file #59164. These units are CSA certified under file #LR11543.

\*See page 252 for specific part numbers.

Refer to Service Manual P-208.

# Brake

## PB-1525 Heavy Duty

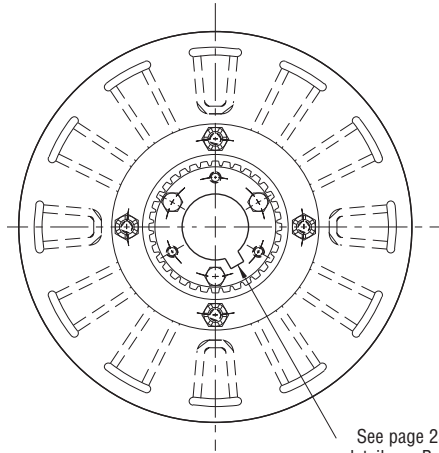

See page 252 for details on Bushings.

**ARMATURE VIEW**

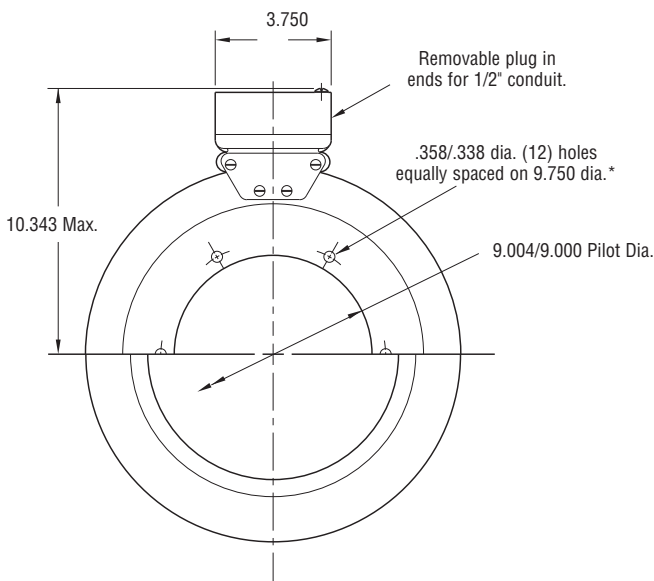

**MAGNET VIEW**

\* Mounting holes are within .010 of true position relative to pilot diameter.

### Customer Shall Maintain:

1. Squareness of magnet mounting face with armature shaft within .006 T.I.R.
2. Concentricity of magnet mounting pilot diameter with armature shaft within .010 T.I.R.

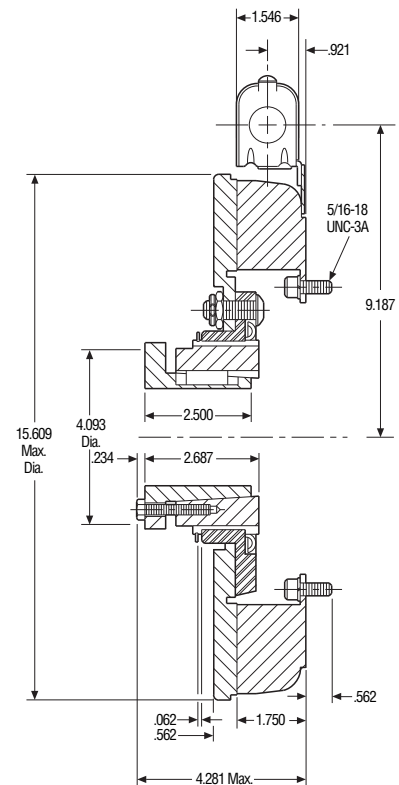

Shaft Size	.750 – 2.687
Static Torque	700 lb. ft.
Maximum Speed	2,000 rpm
Standard Voltage	D.C. 6, 24, 90

All dimensions are nominal unless otherwise noted.

Information on inertia and weights begins on page 239. Coil data is on pages 250 and 251.





**PB-1525 Heavy Duty**

**Drawing I-25634**

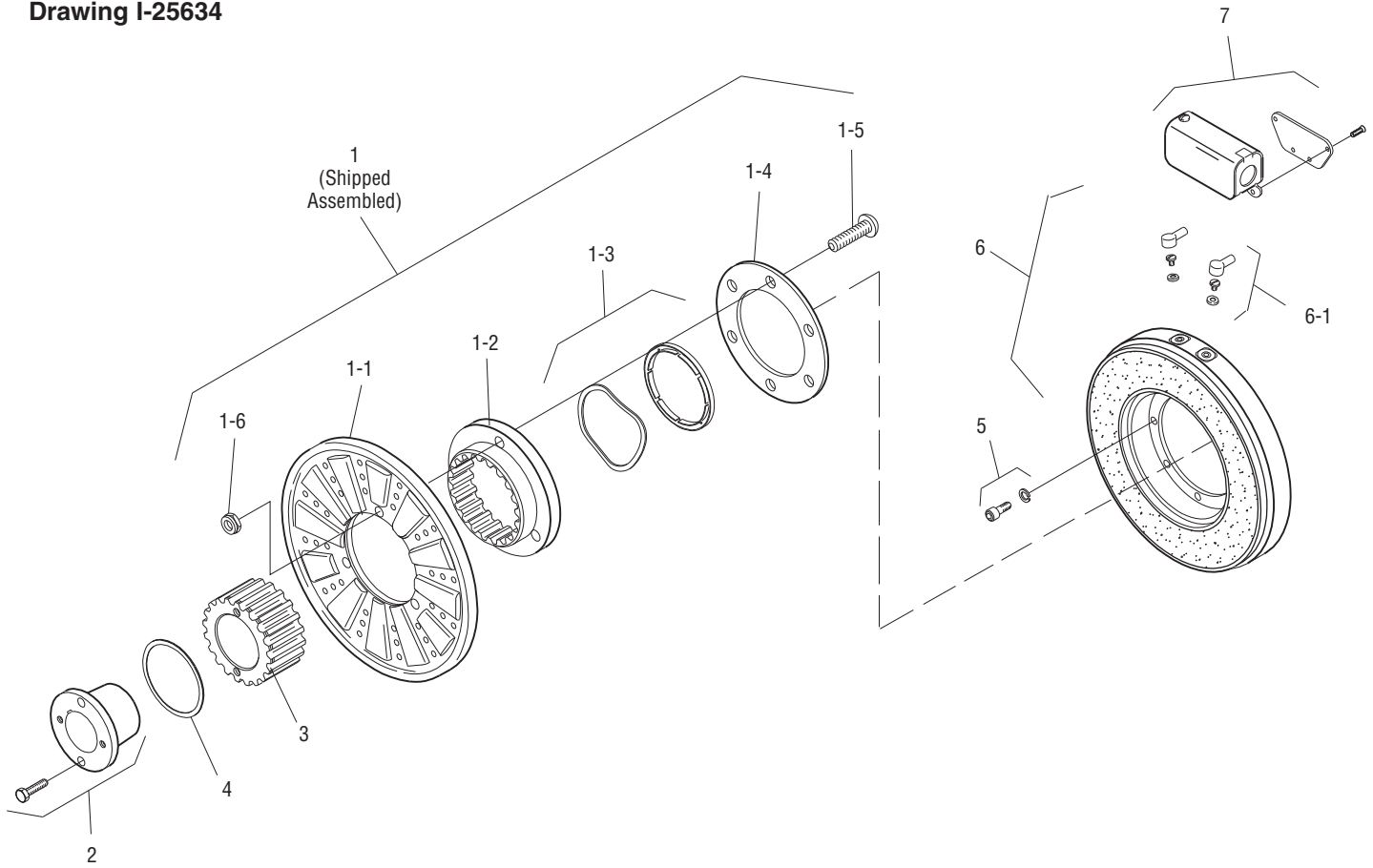

Item	Description	Part Number	Qty.
1	Armature & Splined Adapter	5324-111-001	1
1-1	Armature	5324-111-034	1
1-2	Splined Adapter	104-0011	1
1-3	Autogap Accessory	5323-101-002	1
1-4	Retainer Plate	686-0003	1
1-5	Screw	797-0272	8
1-6	Locknut	661-0004	8
2	Bushing*		1
	3/4" to 2-11/16" Bore	180-0026 to 180-0057	
3	Splined Hub	540-0064	1
4	Retainer Ring	748-0005	1
5	Mounting Accessory - I.M.	5321-101-001	2
6	Magnet - Inside Mounted		1
	6 Volt	5314-631-004	
	24 Volt	5314-631-006	
	90 Volt	5314-631-005	
	†90 Volt	5314-631-001	
6-1	Terminal Accessory	5311-101-001	1
7	Conduit Box	5200-101-011	1

**How to Order:**

1. Specify Bore Size for Item 2.
2. Specify Inside Mounted for Items 5 and 6.
3. Specify Voltage for Item 6.
4. See Controls Section.

**Example:**

PB-1525 Clutch per I-25634 -  
90 Volt, 1-3/4" Bore

These units, when used in conjunction with the correct Warner Electric conduit box, meet the standards of UL508 and are listed under guide card #NMTR, file #59164. These units are CSA certified under file #LR11543.

\*See page 252 for specific part numbers.

Refer to Service Manual P-209.

†Optional LK facing available. For more information, see page 232.

# Motor Brake

# Normal Duty

## MB-825 Flange Mounted

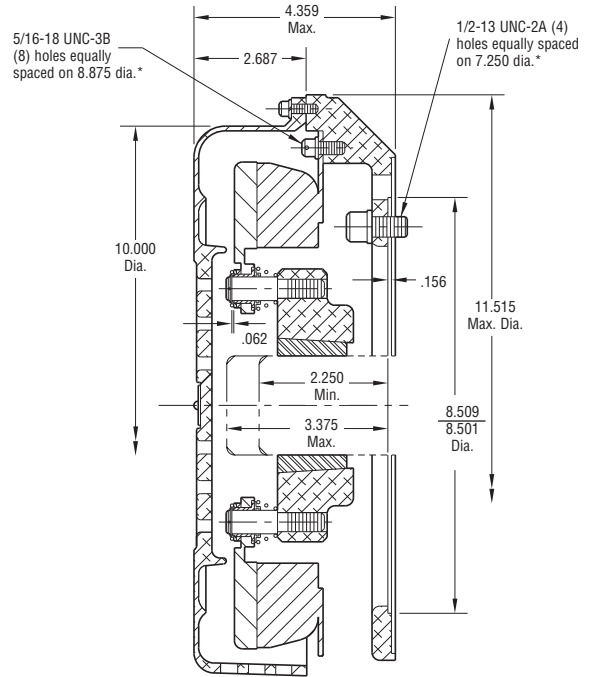
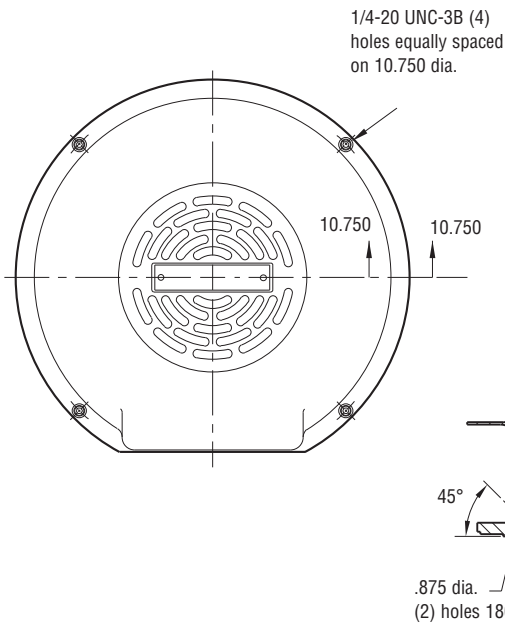

### Installation

\* Mounting holes are within .006 of true position.

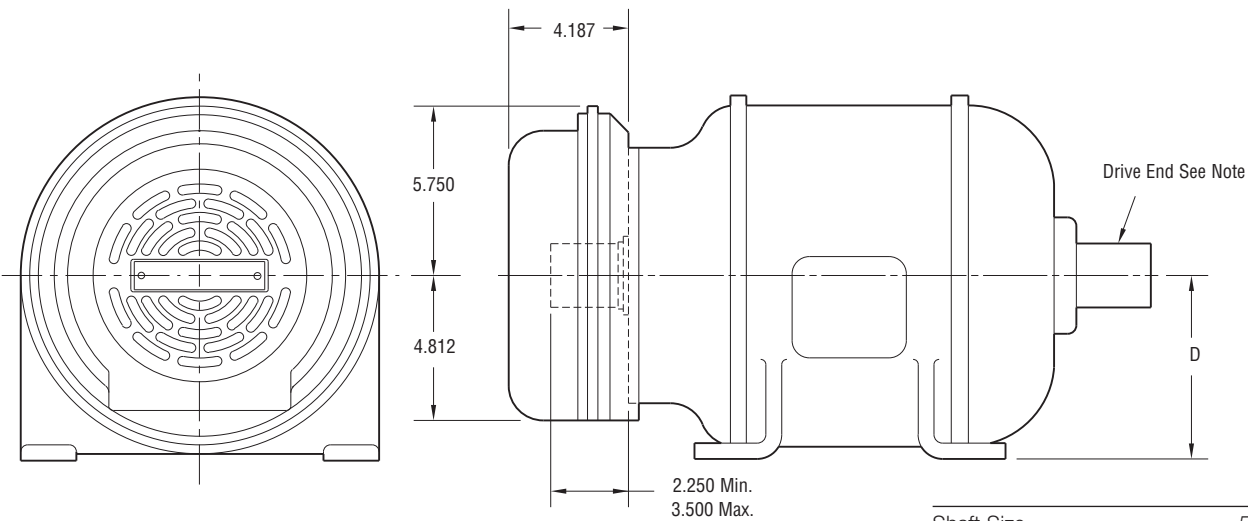

NEMA Frame Sizes	Dim. D
213C & 215C or TC	5.250
254C & 256C or TC	6.250

Shaft Size	.500 – 1.625
Static Torque	80 lb. ft.
Maximum Speed	4,000 rpm
Standard Voltage	D.C. 90



All dimensions are nominal unless otherwise noted.

Information on inertia and weights begins on page 239. Coil data is on pages 250 and 251.

Drawing I-25572

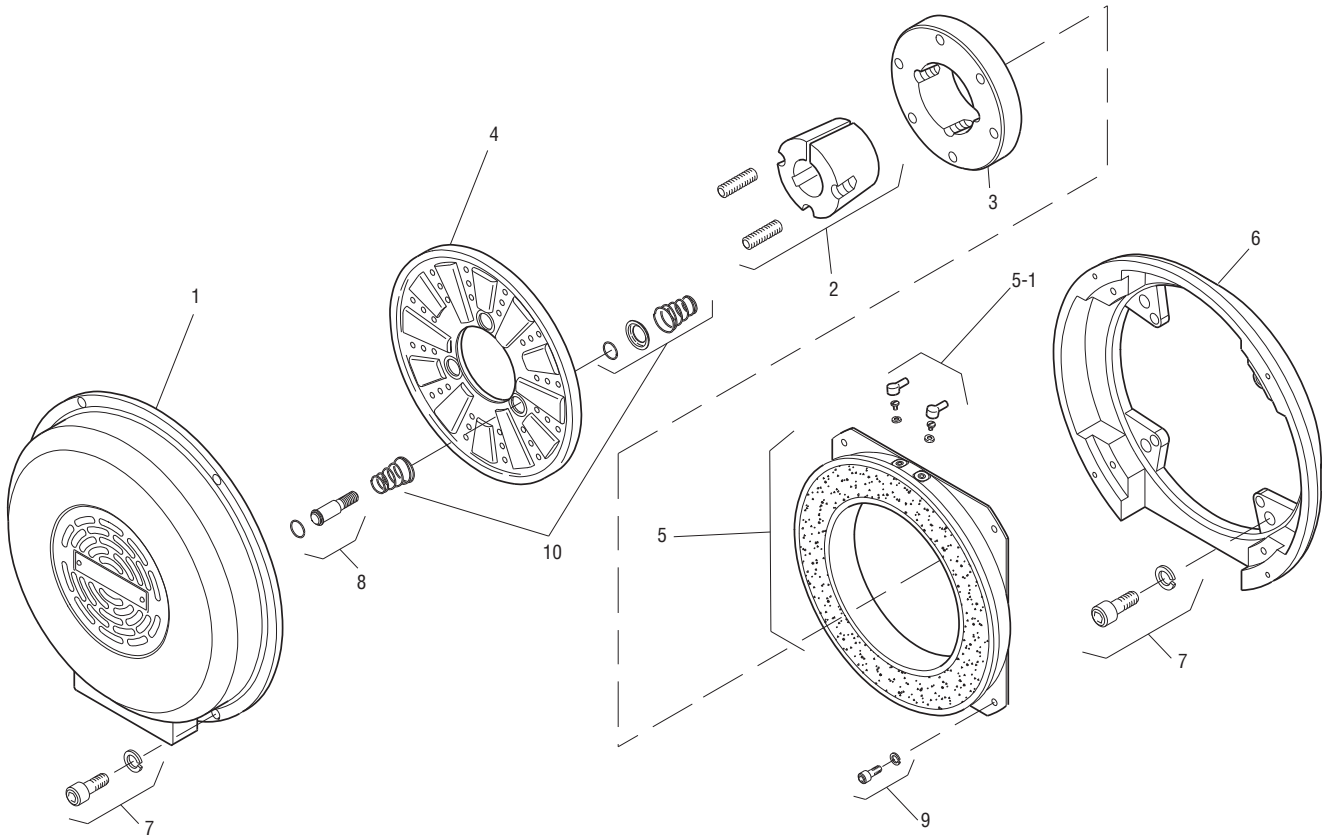

Item	Description	Part Number	Qty.
1	Cover	5351-288-001	1
2	Bushing*	180-0131 to 180-0149	1
3	Armature Hub	540-0394	1
4	Armature	5301-111-018	1
5	Magnet - 90 Volt	5351-631-001	1
5-1	Terminal Accessory	5311-101-001	1
6	Adapter	5351-105-001	1
7	Mounting Accessory	5351-101-003	1
8	Drive Pin and Retainer	5301-101-001	3
9	Mounting Accessory	5321-101-002	1
10	Spring Accessory	5301-101-014	3

**How to Order:**

1. MB-825 Adapts to NEMA C Face, Double Shaft Motors, Frame Sizes 213 C, 215 C, 254 UC and 256 UC.
2. Specify Bore Size for Item 2. (Frame size determines bore).
3. See Controls Section.

**Example:**

MB-825 Motor Brake per I-25572 - 90 Volt, 7/8" Bore

These units meet the standards of UL508 and are listed under guide card #NMTR2, file #59164. These units are CSA certified under file #LR11543.

\*See page 252 for specific part numbers.

Refer to Service Manual P-208.

# Motor Brake

# Heavy Duty

## MB-825 Flange Mounted

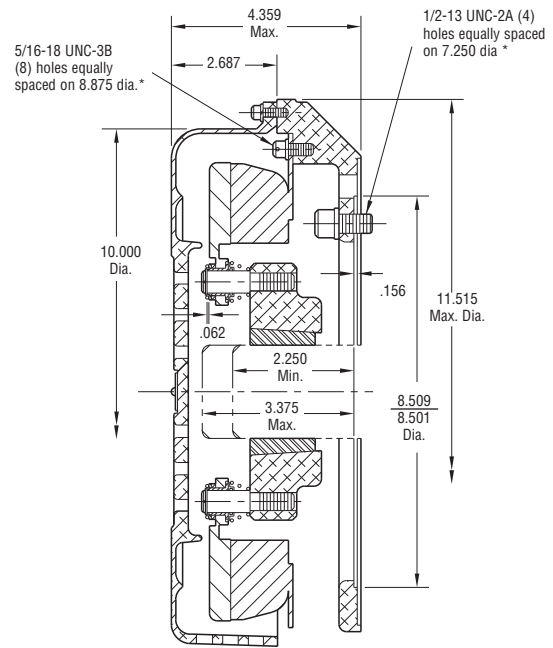
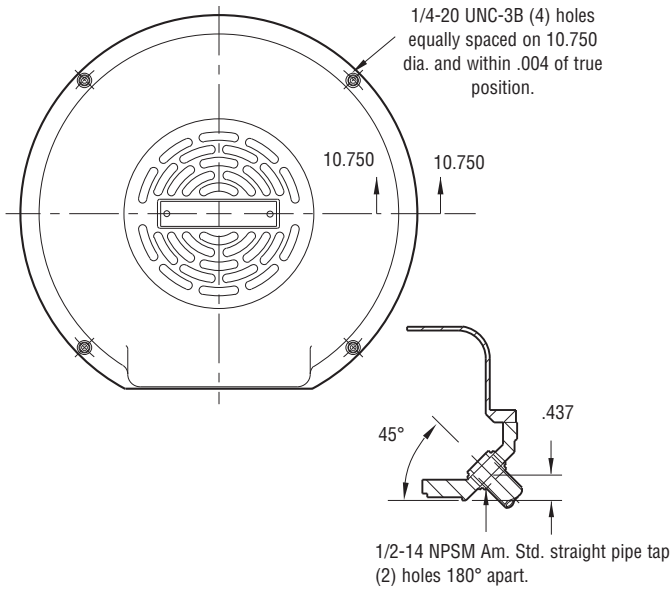

### Installation

\* Mounting holes are within .006 of true position.

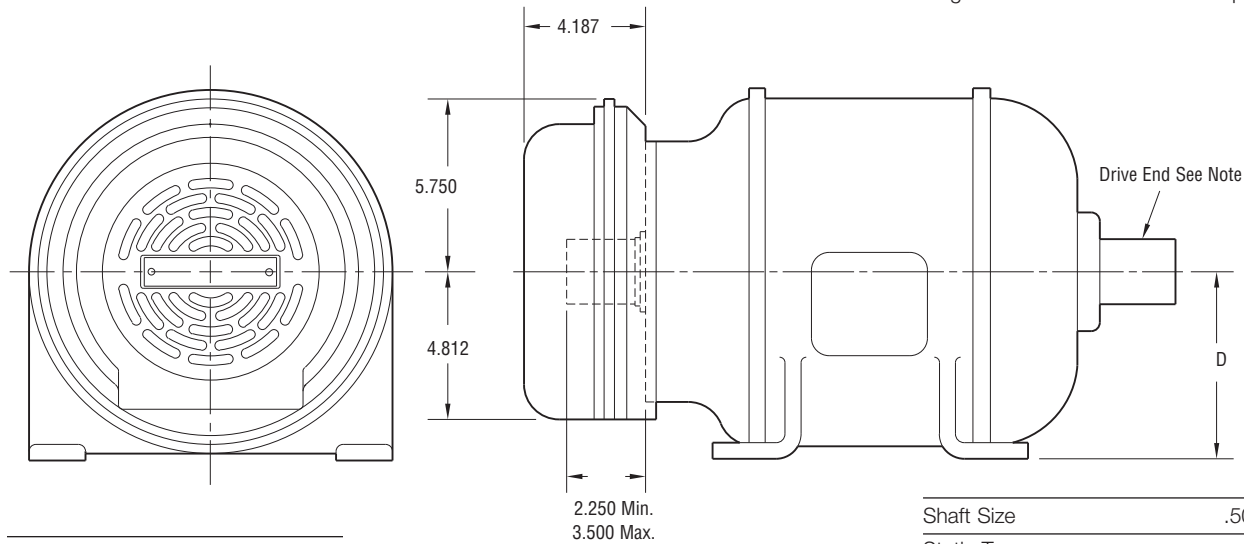

NEMA Frame Sizes	Dim. D
213C & 215C or TC	5.250
254C & 256C or TC	6.250

Shaft Size	.500 – 1.500
Static Torque	80 lb. ft.
Maximum Speed	4,000 rpm
Standard Voltage	D.C. 90

All dimensions are nominal unless otherwise noted.

Information on inertia and weights begins on page 239. Coil data is on pages 250 and 251.



## MB-825 Flange Mounted

Drawing I-25576

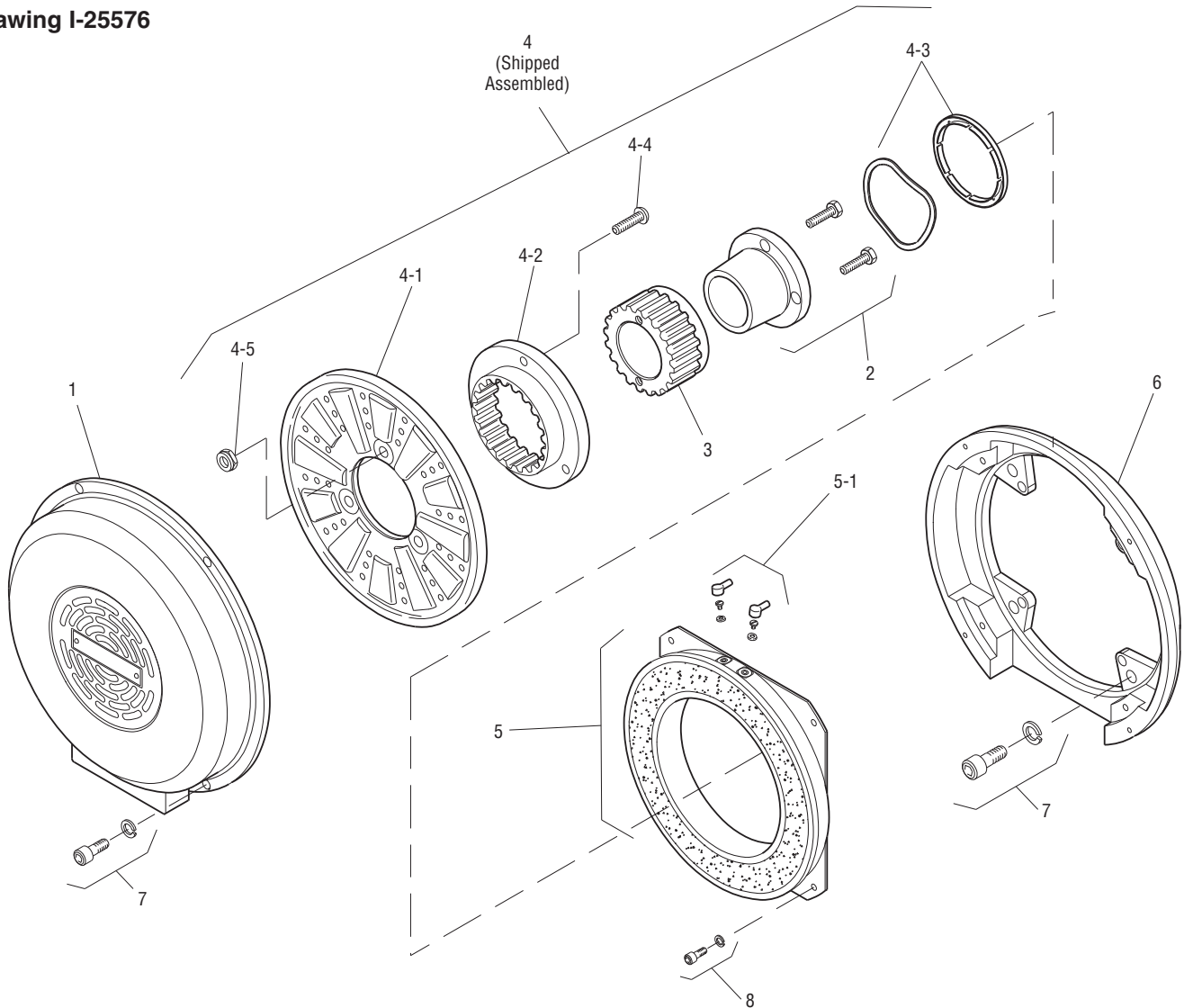

Item	Description	Part Number	Qty.
1	Cover	5351-288-001	1
2	Bushing*		1
	1/2" to 1-1/2" Bore	180-0002 to 180-0018	
3	Armature Hub	540-0057	1
4	Armature Assembly	5321-111-001	1
4-1	Armature	5321-111-022	1
4-2	Splined Adapter	104-0008	1
4-3	Autogap Accessory	5321-101-006	1
4-4	Screw	797-0272	3
4-5	Locknut	661-0004	3
5	Magnet	5351-631-001	1
5-1	Terminal Accessory	5311-101-001	1
6	Adapter	5351-105-001	1
7	Mounting Accessory	5351-101-003	1
8	Mounting Accessory	5321-101-002	1

### How to Order:

1. MB-825 Adapts to NEMA C Face, Double Shaft Motors, Frame Sizes 213 C, 215 C, 254 UC and 256 UC.
2. Specify Bore Size for Item 4. (Frame size determines bore).
3. See Controls Section.

### Example:

MB-825 Motor Brake per I-25576 - 90 Volt, 7/8" Bore

These units meet the standards of UL508 and are listed under guide card #NMTR2, file #59164. These units are CSA certified under file #LR11543.

\*See page 252 for specific part numbers.

Refer to Service Manual P-208.

# Motor Brake

# Normal Duty

## MB-1000 Flange Mounted

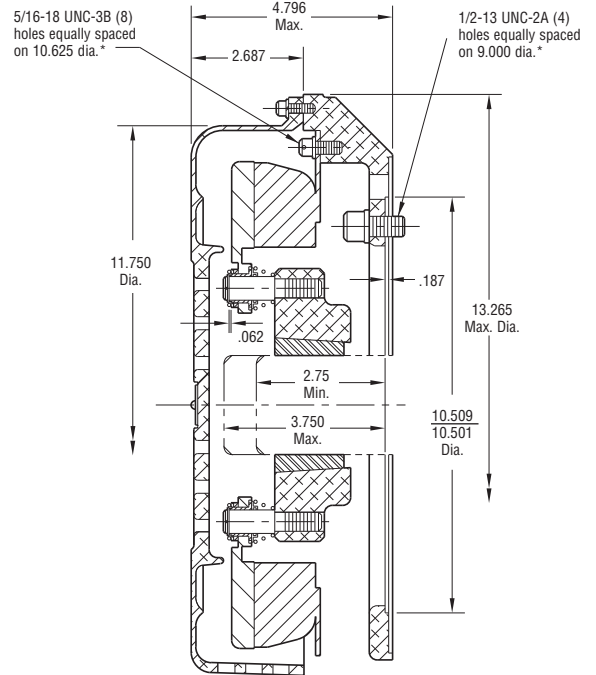
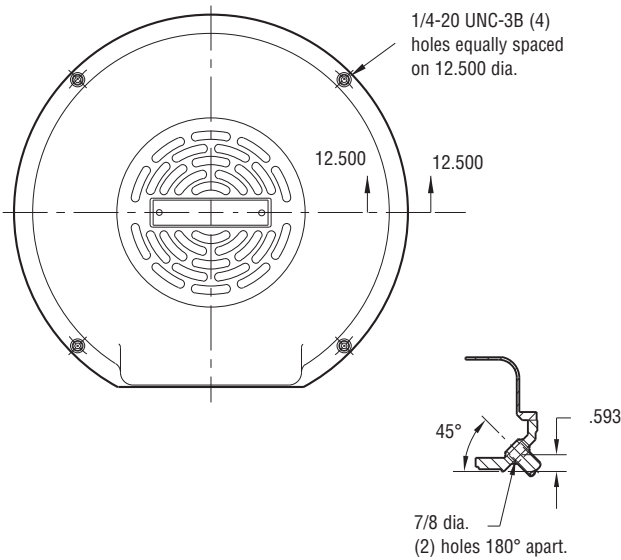

## Installation

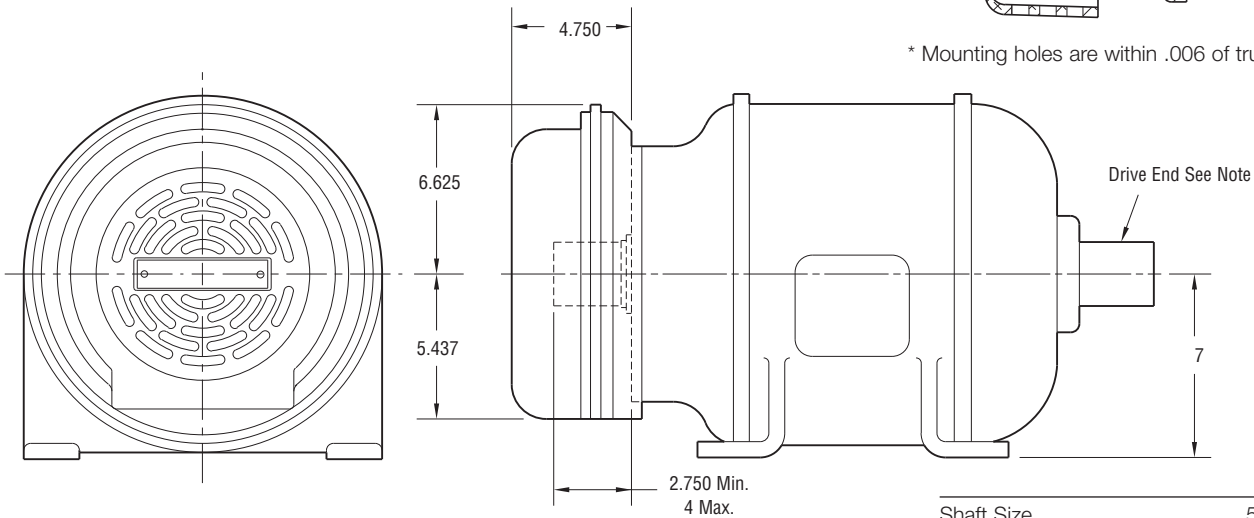

\* Mounting holes are within .006 of true position.

Shaft Size	.500 – 2.500
Static Torque	160 lb. ft.
Maximum Speed	3,600 rpm
Standard Voltage	D.C. 90

All dimensions are nominal unless otherwise noted.

Information on inertia and weights begins on page 239. Coil data is on pages 250 and 251.



MB-1000 Flange Mounted

Drawing I-25591

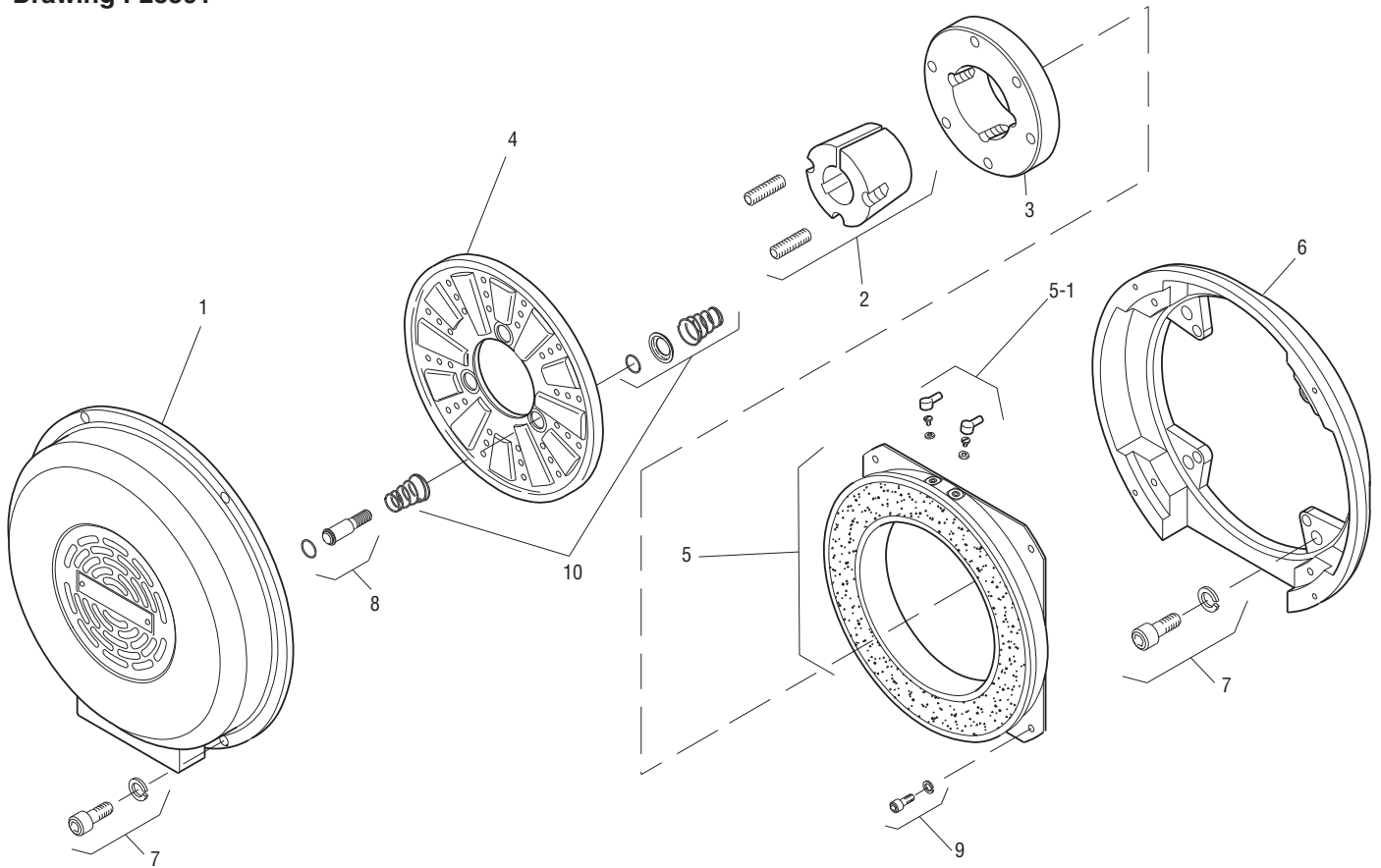

Item	Description	Part Number	Qty.
1	Cover	5352-288-001	1
2	Bushing*		1
	1/2" to 2-1/2" Bore	180-0185 to 180-0217	
3	Armature Hub	540-0313	1
4	Armature	5302-111-013	1
5	Magnet - 90 Volt	5352-631-001	1
5-1	Terminal Accessory	5311-101-001	1
6	Adapter	5352-105-001	1
7	Mounting Accessory	5351-101-003	1
8	Drive Pin and Retainer	5301-101-001	3
9	Mounting Accessory	5321-101-002	2
10	Spring Accessory	5301-101-014	3

**How to Order:**

1. MB-1000 Adapts to NEMA C Face, Double Shaft Motors, Frame Sizes 284 UC and 286 UC.
2. Specify Bore Size for Item 2. (Frame size determines bore).
3. See Controls Section.

**Example:**

MB-1000 Motor Brake per I-25591 - 90 Volt, 1-3/8" Bore

These units meet the standards of UL508 and are listed under guide card #NMTR2, file #59164. These units are CSA certified under file #LR11543.

\*See page 252 for specific part numbers.

Refer to Service Manual P-208.

# Motor Brake

# Heavy Duty

## MB-1000 Flange Mounted

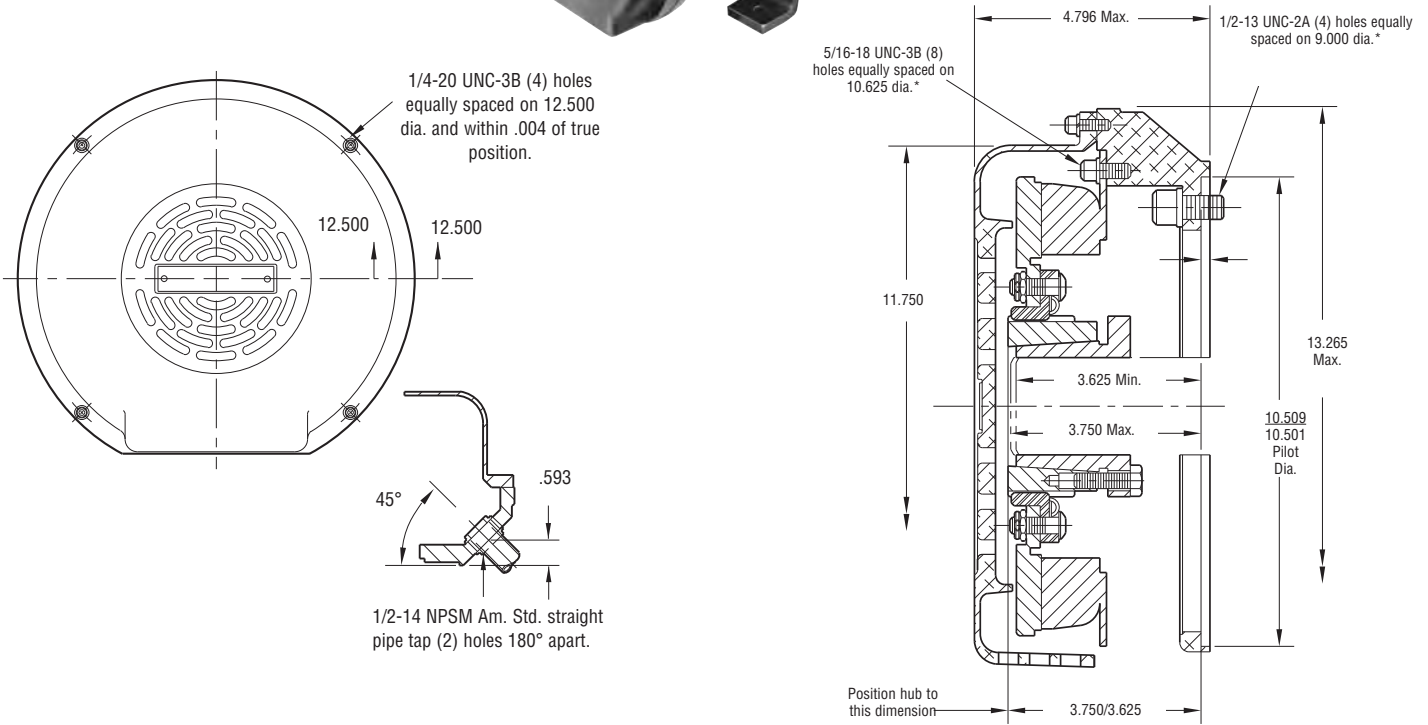

### Installation

\* Mounting holes are within .006 of true position.

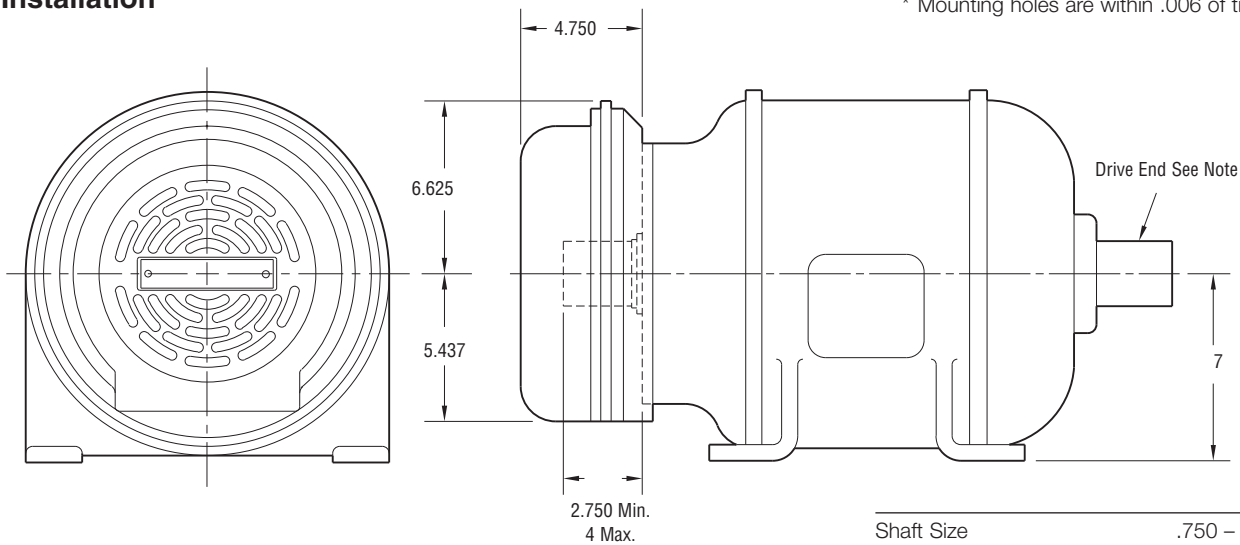

Shaft Size	.750 – 2.687
Static Torque	160 lb. ft.
Maximum Speed	3,600 rpm
Standard Voltage	D.C. 90

All dimensions are nominal unless otherwise noted.

Information on inertia and weights begins on page 239. Coil data is on pages 250 and 251.





MB-1000 Flange Mounted

Drawing I-25595

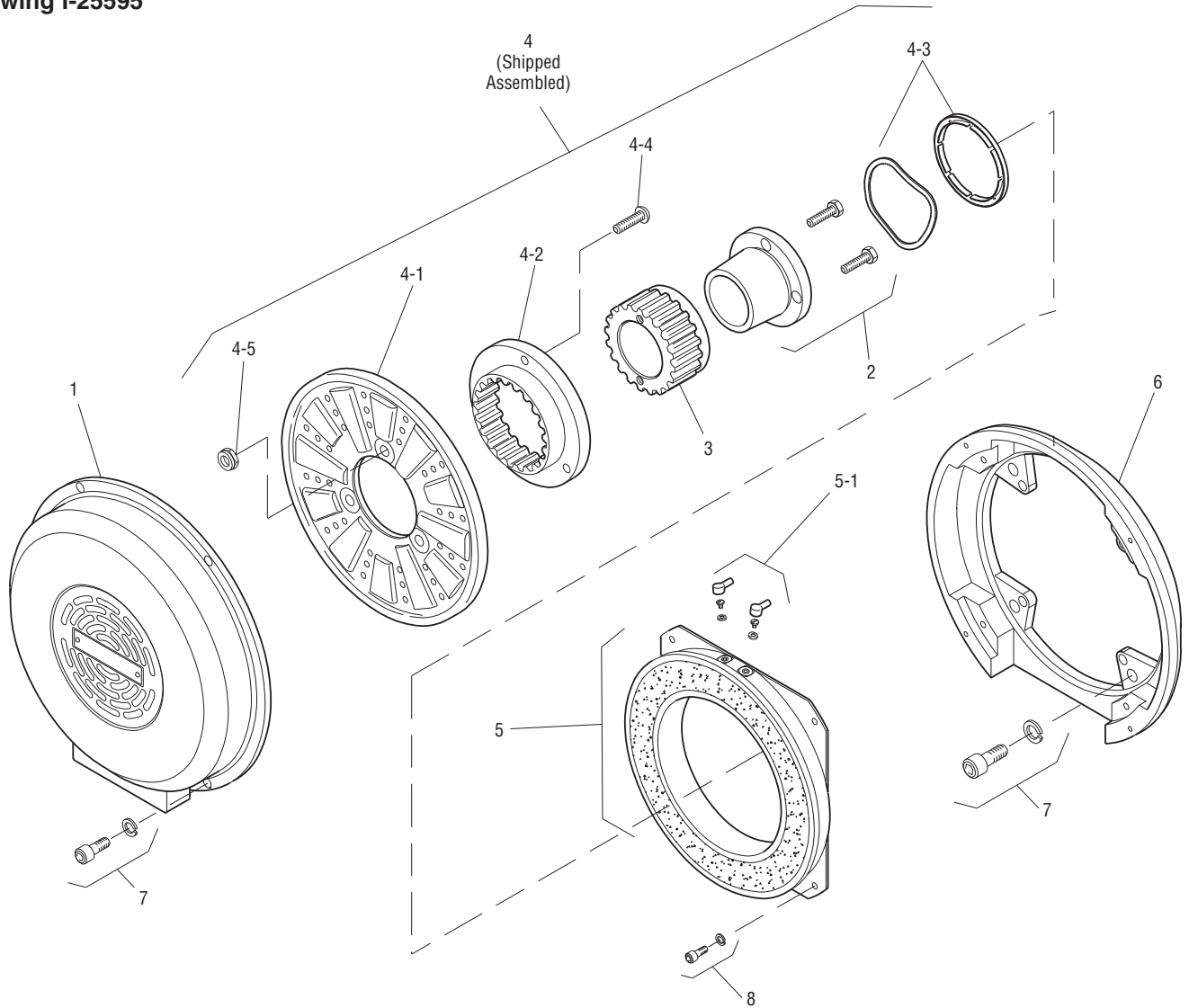

Item	Description	Part Number	Qty.
1	Cover	5352-288-001	1
2	Bushing*		1
	3/4" to 2-11/16" Bore	180-0026 to 180-0057	
3	Armature Hub	540-0062	1
4	Armature Assembly	5322-111-002	1
4-1	Armature	5322-111-036	1
4-2	Splined Adapter	104-0009	1
4-3	Autogap Accessory	5322-101-004	1
4-4	Screw	797-0272	3
4-5	Locknut	661-0004	3
5	Magnet	5352-631-001	1
5-1	Terminal Accessory	5311-101-001	1
6	Adapter	5352-105-001	1
7	Mounting Accessory	5351-101-003	2
8	Mounting Accessory	5321-101-002	1

**How to Order:**

1. MB-1000 Adapts to NEMA C Face, Double Shaft Motors, Frame Sizes 284 UC and 286 UC.
2. Specify Bore Size for Item 4. (Frame size determines bore).
3. See Controls Section.

**Example:**

MB-1000 Motor Brake per I-25595 - 90 Volt, 1-3/8" Bore  
 These units meet the standards of UL508 and are listed under guide card #NMTR2, file #59164. These units are CSA certified under file #LR11543.

\*See page 252 for specific part numbers.  
 Refer to Service Manual P-208.

# Motor Brake

# Normal Duty

## MB-1225 Flange Mounted

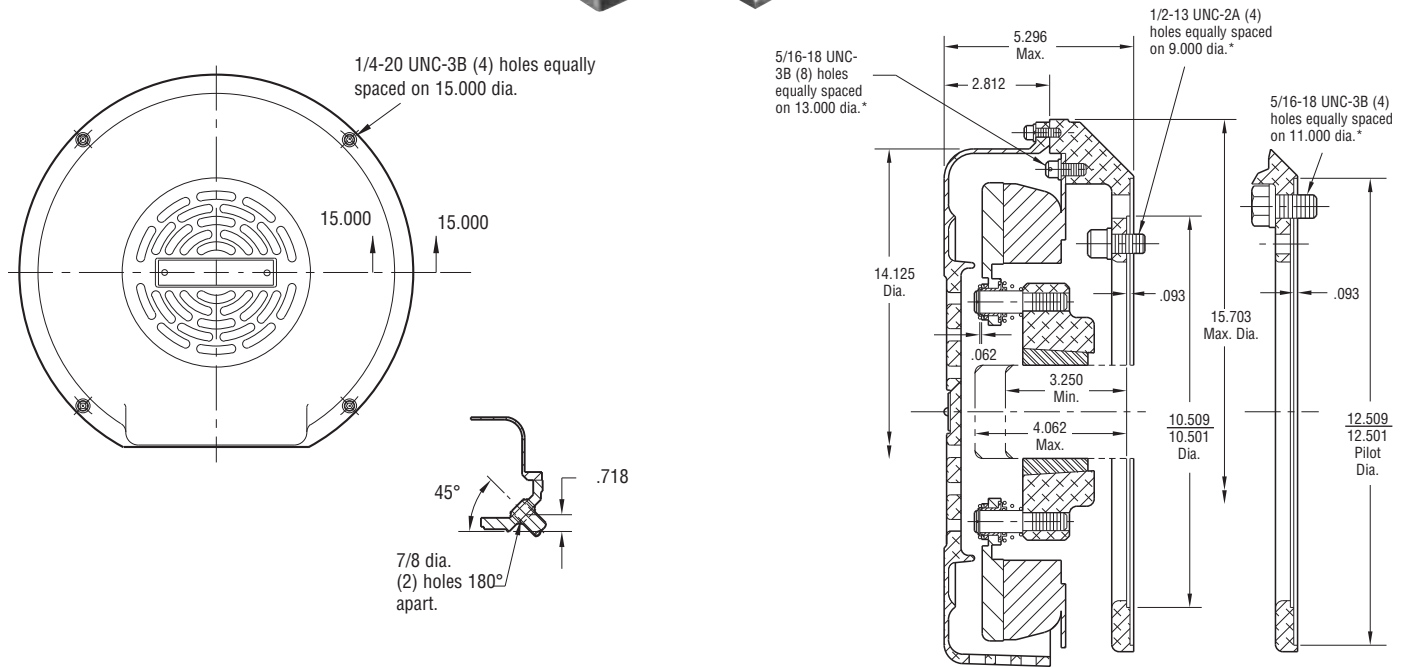

### Installation

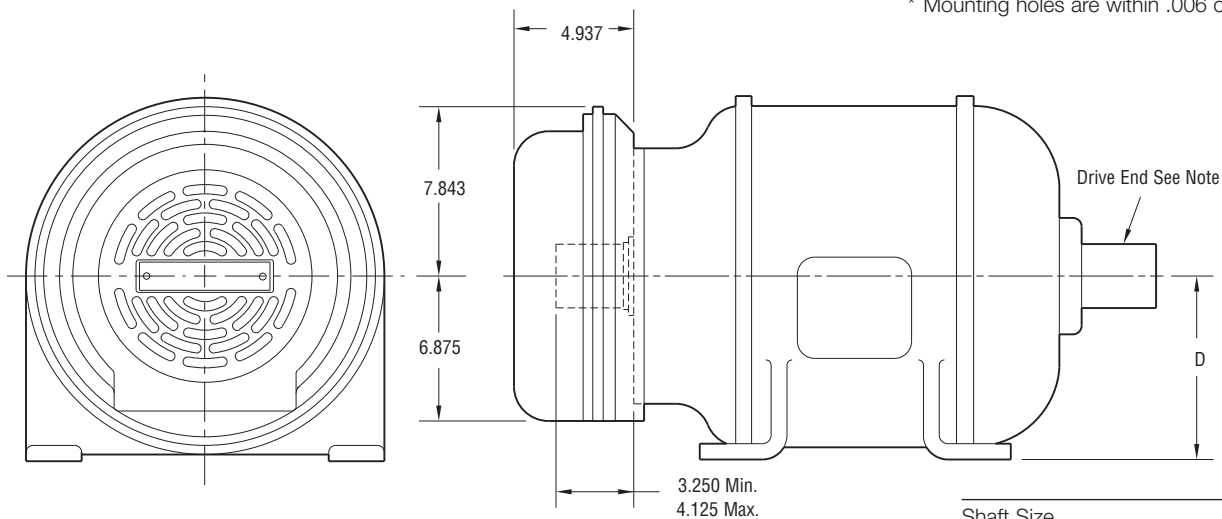

\* Mounting holes are within .006 of true position.

NEMA Frame Sizes	Dim. D
284C & 286C or TC	7
324C & 326C or TC	8
364C & 365C or TC	9

Shaft Size	.500 – 2.500
Static Torque	260 lb. ft.
Maximum Speed	3,000 rpm
Standard Voltage	D.C. 90



All dimensions are nominal unless otherwise noted.

Information on inertia and weights begins on page 239. Coil data is on pages 250 and 251.

MB-1225 Flange Mounted

Drawing I-25614

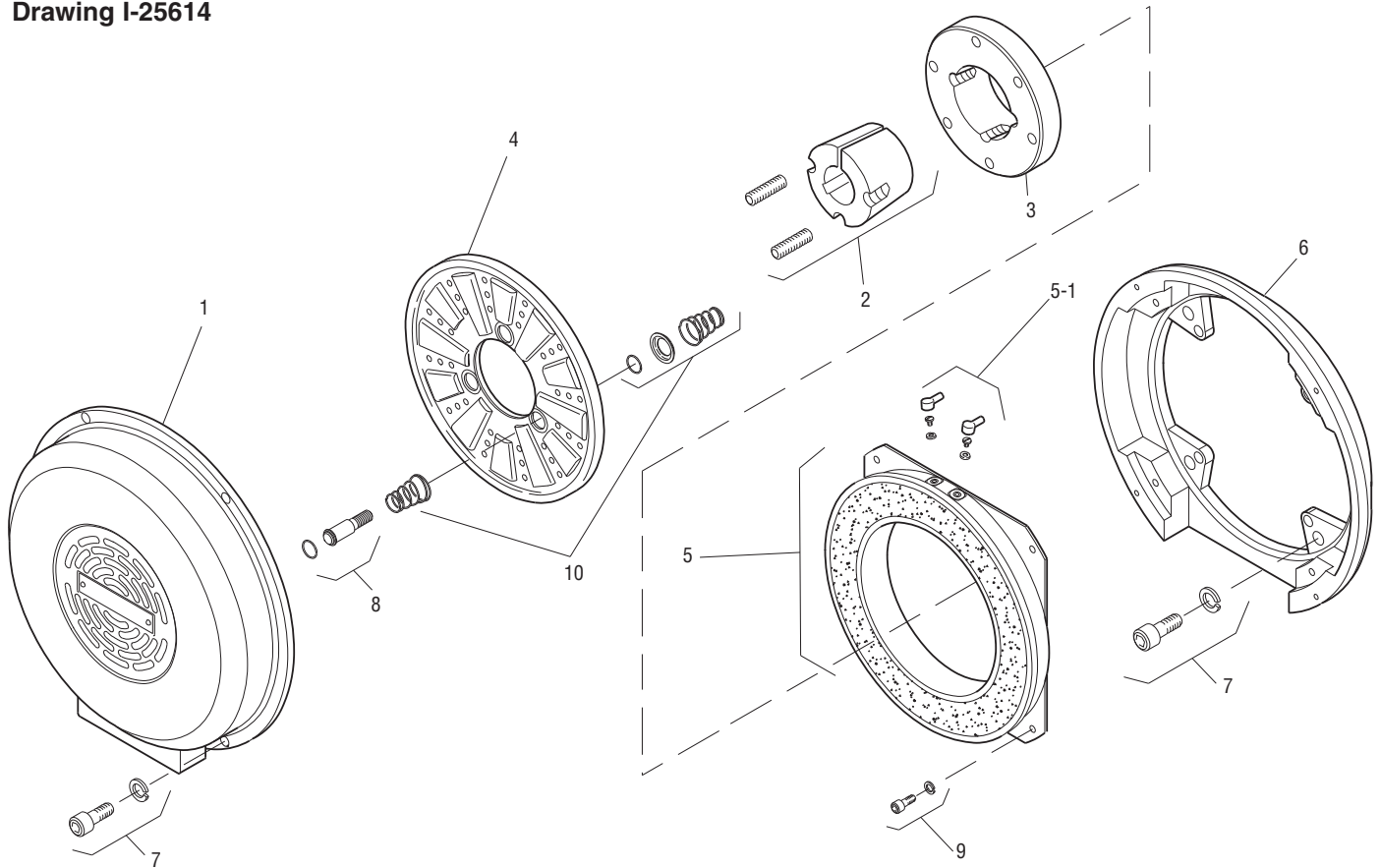

Item	Description	Part Number	Qty.
1	Cover	5353-288-001	1
2	Bushing*	1/2" to 2-1/2" Bore 180-0185 to 180-0217	1
3	Armature Hub	540-0014	1
4	Armature	5303-111-009	1
5	Magnet - 90 Volt	5353-631-001	1
5-1	Terminal Accessory	5311-101-001	1
6	Adapter	5353-105-002	1
7	Mounting Accessory	5351-101-003	1
8	Drive Pin and Retainer	5301-101-001	4
9	Mounting Accessory	5321-101-002	2
10	Spring Accessory	5303-101-006	4

**How to Order:**

1. MB-1225 Adapts to NEMA C Face, Double Shaft Motors, Frame Sizes 284, 284 UC, 324 UC, 326 UC, 364 UC and 365 UC.
2. Specify Bore Size for Item 2. (Frame size determines bore).
3. See Controls Section.

**Example:**

MB-1225 Motor Brake per I-25614 - 90 Volt, 1-5/8" Bore

These units meet the standards of UL508 and are listed under guide card #NMTR2, file #59164. These units are CSA certified under file #LR11543.

\*See page 252 for specific part numbers.

Refer to Service Manual P-208.

# Motor Brake

# Heavy Duty

## MB-1225 Flange Mounted

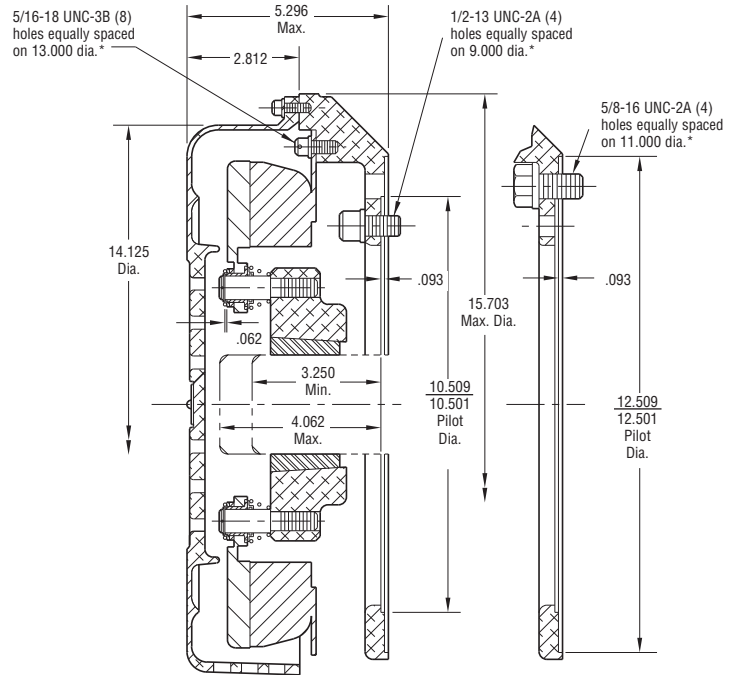
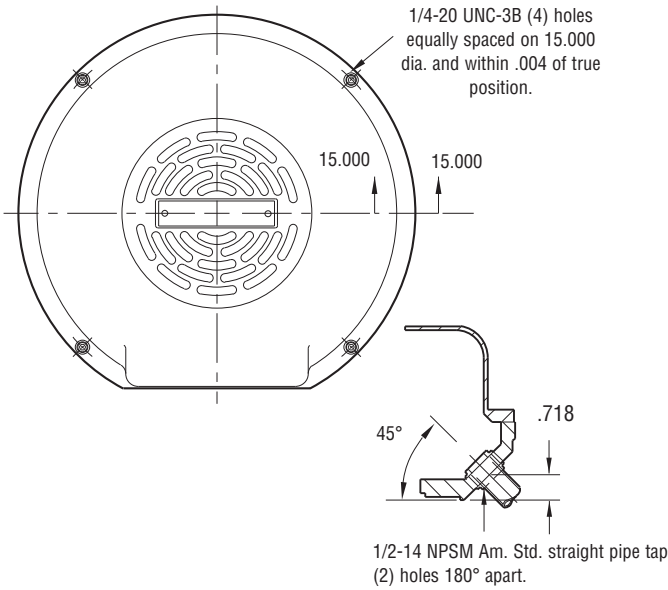

## Installation

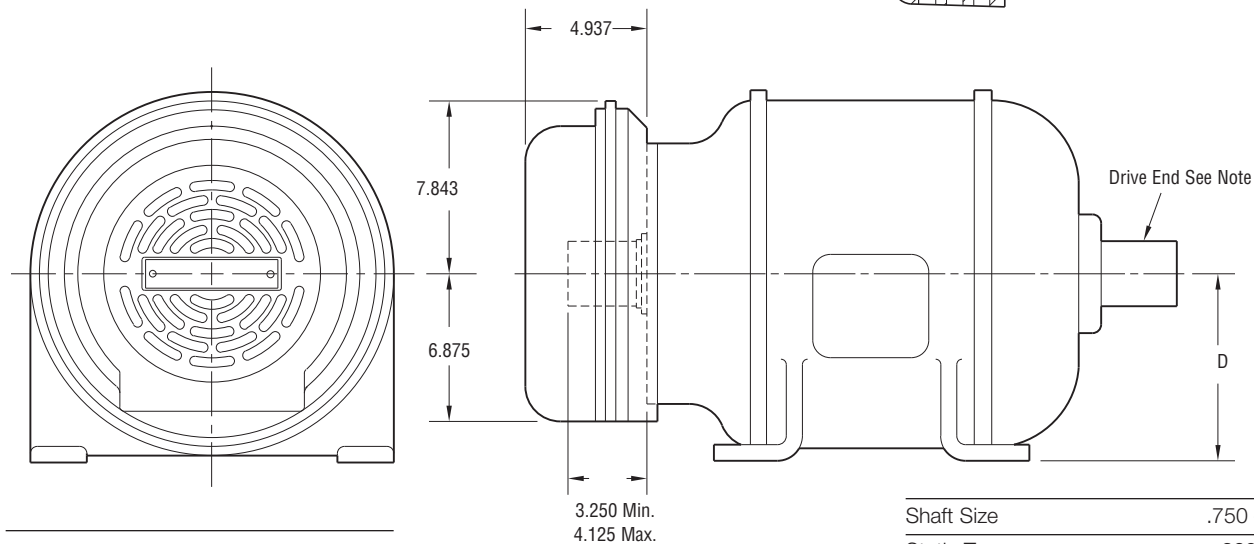

NEMA Frame Sizes	Dim. D
284C & 286C or TC	7
324C & 326C or TC	8
364C & 365C or TC	9

Shaft Size	.750 – 2.687
Static Torque	260 lb. ft.
Maximum Speed	3,000 rpm
Standard Voltage	D.C. 90



All dimensions are nominal unless otherwise noted.

Information on inertia and weights begins on page 239. Coil data is on pages 250 and 251.

MB-1225 Flange Mounted

Drawing I-25618

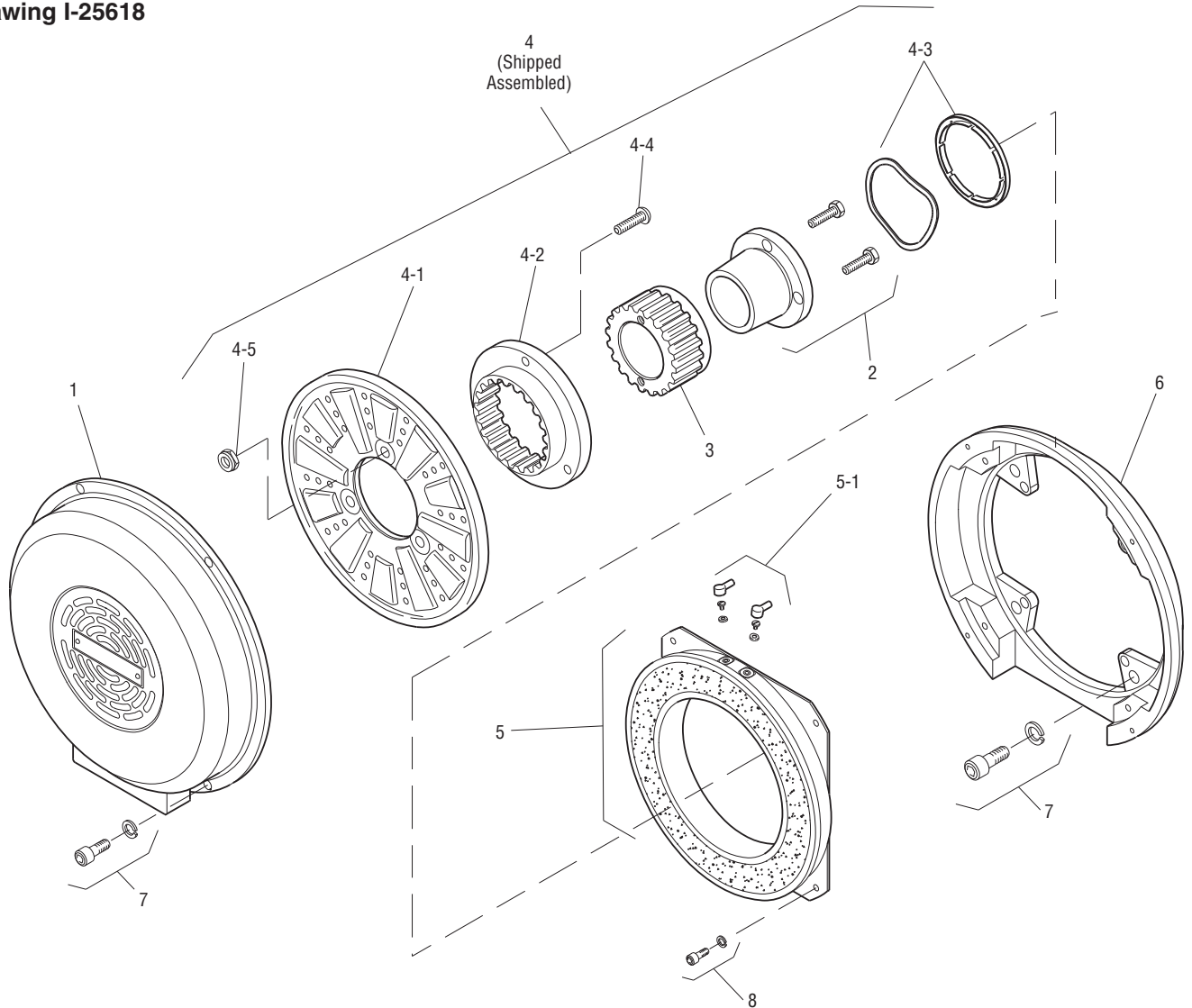

Item	Description	Part Number	Qty.
1	Cover	5353-288-001	1
2	Bushing*	180-0026 to 180-0057	1
3	Armature Hub	540-0064	1
4	Armature Assembly	5323-111-001	1
4-1	Armature	5323-111-034	1
4-2	Splined Adapter	104-0010	1
4-3	Autogap Accessory	5323-101-002	1
4-4	Screw	797-0281	4
4-5	Locknut	661-0005	4
5	Magnet	5353-631-001	1
5-1	Terminal Accessory	5311-101-001	1
6	Adapter	5353-105-002	1
7	Mounting Accessory	5351-101-003	2
8	Mounting Accessory	5321-101-002	1

**How to Order:**

1. MB-1225 Adapts to NEMA C Face, Double Shaft Motors, Frame Sizes 284, 284 UC, 324 UC, 326 UC, 364 UC and 365 UC.
2. Specify Bore Size for Item 2. (Frame size determines bore).
3. See Controls Section.

**Example:**

MB-1225 Motor Brake per I-25618 - 90 Volt, 1-5/8" Bore  
 These units meet the standards of UL508 and are listed under guide card #NMTR2, file #59164. These units are CSA certified under file #LR11543.

\*See page 252 for specific part numbers.

Refer to Service Manual P-208.

# Clutch/Brake

## PCB-825 Normal Duty



See page 252 for details on Bushings.

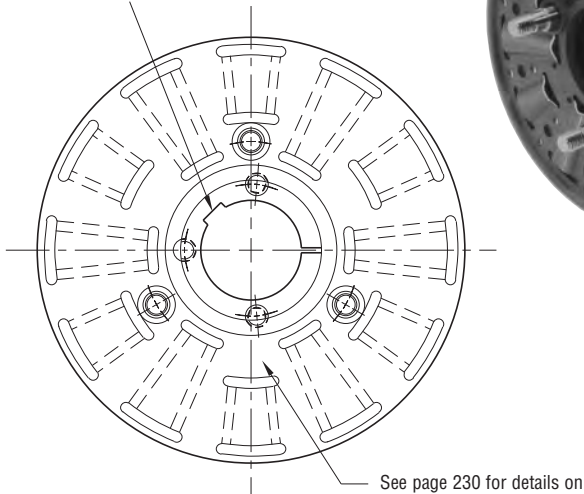

**ARMATURE VIEW**

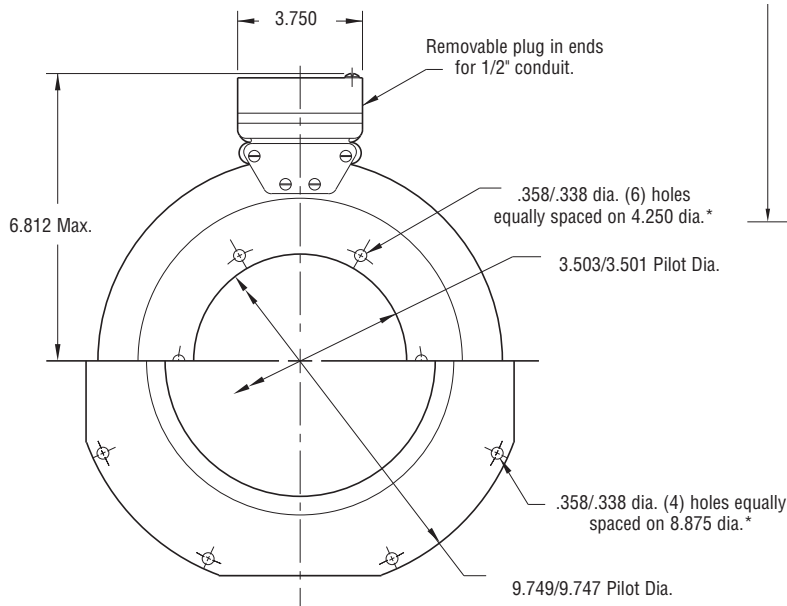

**MAGNET VIEW  
(Inside & Outside Mounted)**

### Customer Shall Maintain:

1. Concentricity of brake mounting pilot diameter with mounting shaft within .010 T.I.R.
2. Squareness of brake magnet mounting face with mounting shaft within .006 T.I.R. measured at magnet mounting bolt circle.

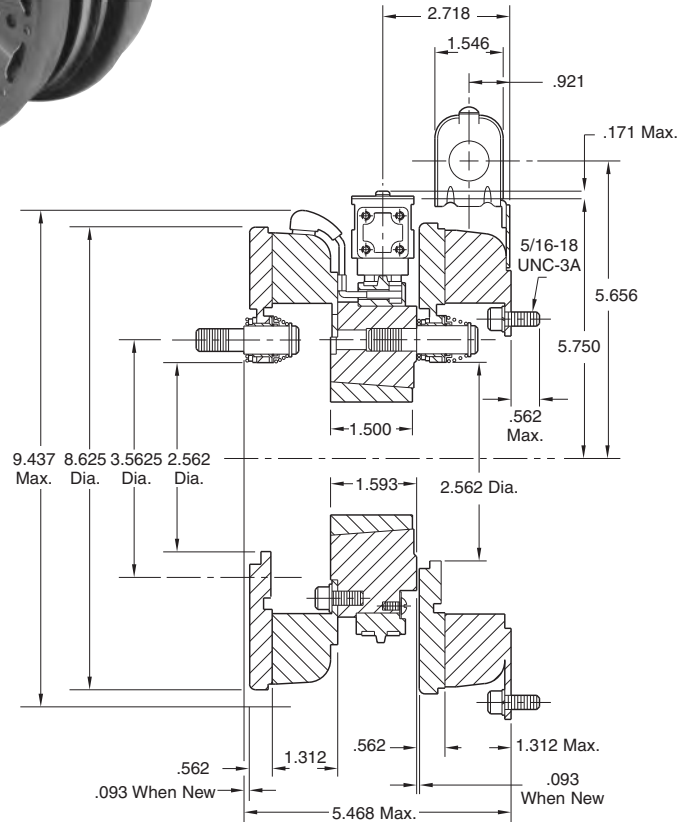

\* Mounting holes are within .010 of true position relative to pilot diameter.

Shaft Size	.500 – 1.625
Static Torque	125 lb. ft.
Maximum Speed	4,000 rpm
Standard Voltage	D.C. 6, 24, 90

All dimensions are nominal unless otherwise noted.

Information on inertia and weights begins on page 239. Coil data is on pages 250 and 251.



## PCB-825 Normal Duty

Drawing I-25568

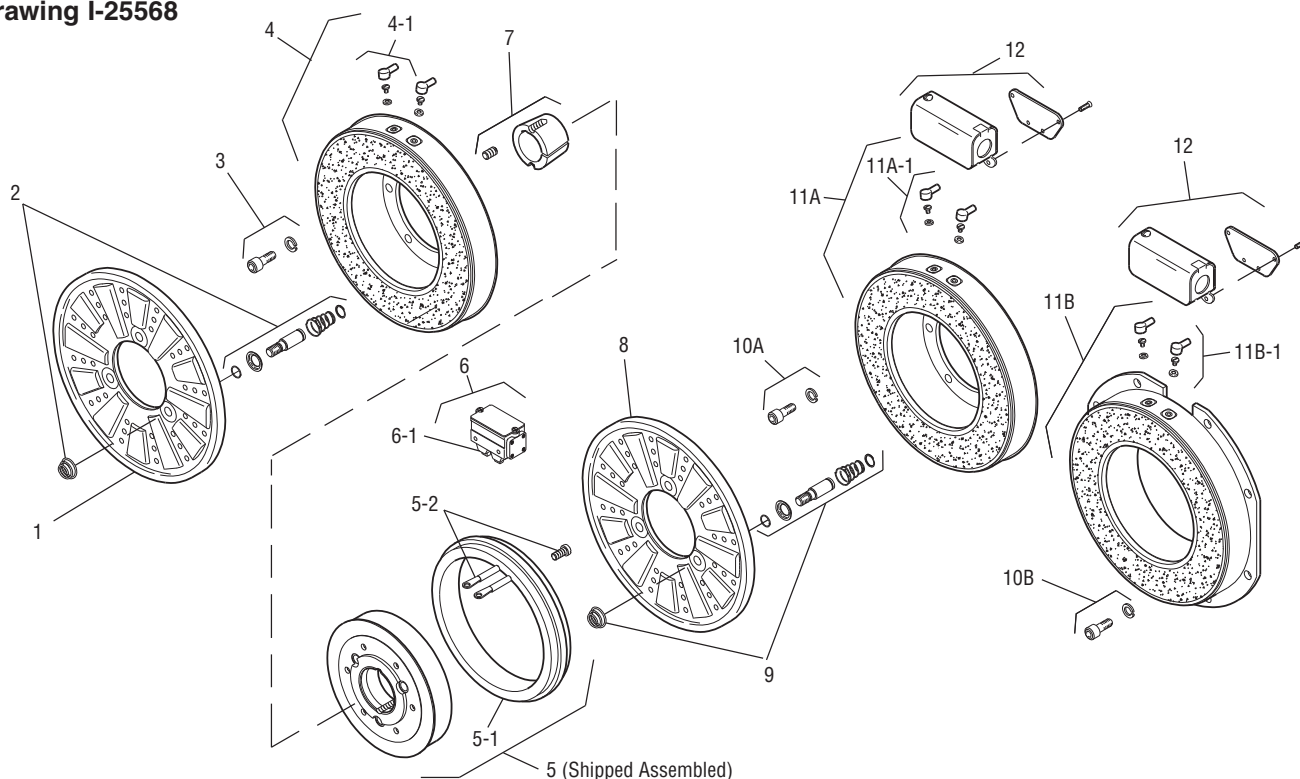

Item	Description	Part Number	Qty.
1	Armature	5301-111-018	1
2	Autogap Accessory	5201-101-008	3
3	Mounting Accessory	5321-101-001	1
4	Magnet		1
	6 Volt	5301-631-002	
	24 Volt	5301-631-004	
	90 Volt	5301-631-005	
4-1	Terminal Accessory	5311-101-001	1
5	Magnet Hub		1
	Left Hand (shown)	5301-541-001	
	Right Hand	5301-541-002	
5-1	Collector Ring	5301-749-001	1
5-2	Collector Ring Assembly	5301-101-002	1
6	Brushholder	5300-178-001	1
6-1	Brush	176-0001	4
7	Bushing*		1
	1/2" to 1-5/8" Bore	180-0131 to 180-0149	
8	Armature	5301-111-018	1
9	Autogap Accessory	5201-101-008	3
10A	Mounting Accessory - I.M.	5321-101-001	1
10B	Mounting Accessory - O.M.	5321-101-002	1
11A	Magnet - Inside Mounted		1
	6 Volt	5311-631-002	
	24 Volt	5311-631-003	
	90 Volt	5311-631-004	

Item	Description	Part Number	Qty.
11A-1	Terminal Accessory	5311-101-001	1
11B	Magnet - Outside Mounted		1
	6 Volt	5311-631-007	
	24 Volt	5311-631-009	
	90 Volt	5311-631-008	
11B-1	Terminal Accessory	5311-101-001	1
12	Conduit Box	5200-101-011	1

### How to Order:

1. Specify Voltage for Item 4 and Item 11A or 11B.
2. Specify left hand or right hand hub for Item 5. Bushing enters from magnet side for L.H. hub and from hub side for R.H.
3. Specify Bore Size for Item 7.
4. Specify Inside Mounted for Items 10A and 11A or Outside Mounted for Items 10B and 11B.
5. See Controls Section.

### Example:

PCB-825 Clutch Brake per I-25568 -  
90 Volt, Left Hand hub, 1" Bore, Inside Mounted

These units meet standards set forth in UL508 and are listed under guide card #NMTR2, file #59164. These units are CSA certified under file #LR11543

\*See page 252 for specific part numbers.

Refer to Service Manual P-205.

# Clutch/Brake

## PCB-825 Heavy Duty



.271/.263 dia. (5) holes (hub) equally spaced on 2.015 dia. and within .003 of true position in relation to 2.313/2.311 pilot dia.

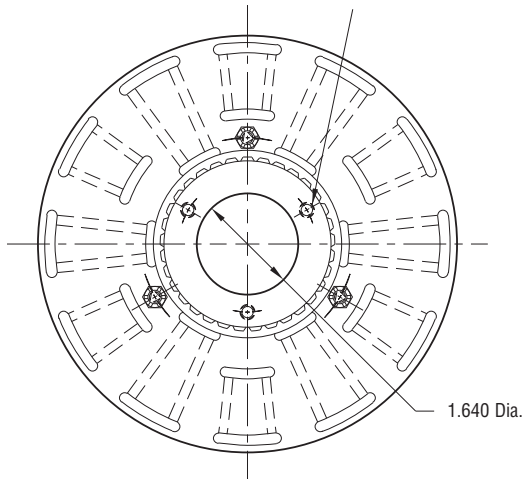

**ARMATURE VIEW**

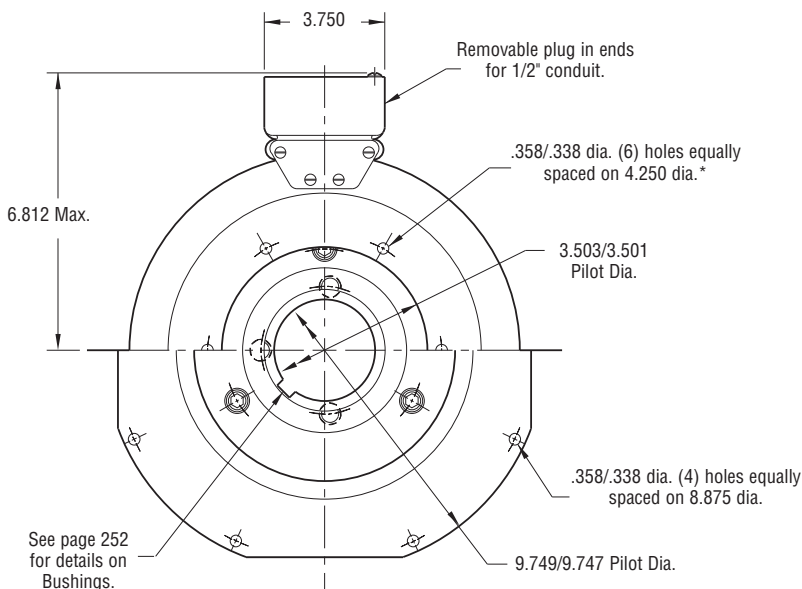
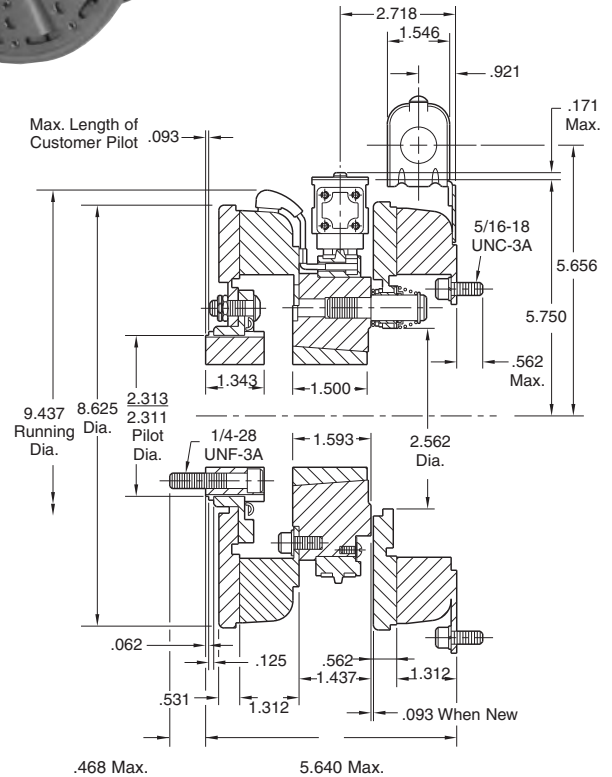

**MAGNET VIEW  
(Inside & Outside Mounted)**

\* Mounting holes are within .010 of true position relative to pilot diameter.

### Customer Shall Maintain:

1. Concentricity of brake magnet mounting pilot diameter with mounting shaft within .010 T.I.R.
2. Squareness of brake magnet mounting face with magnet mounting shaft within .006 T.I.R.
3. Splined hub pilot diameter to be concentric with splined armature center of rotation within .010 T.I.R.

Shaft Size	.500 – 1.625
Static Torque	125 lb. ft.
Maximum Speed	4,000 rpm
Standard Voltage	D.C. 6, 24, 90

All dimensions are nominal unless otherwise noted.

Information on inertia and weights begins on page 239. Coil data is on pages 250 and 251.





## PCB-825 Heavy Duty

Drawing I-25569

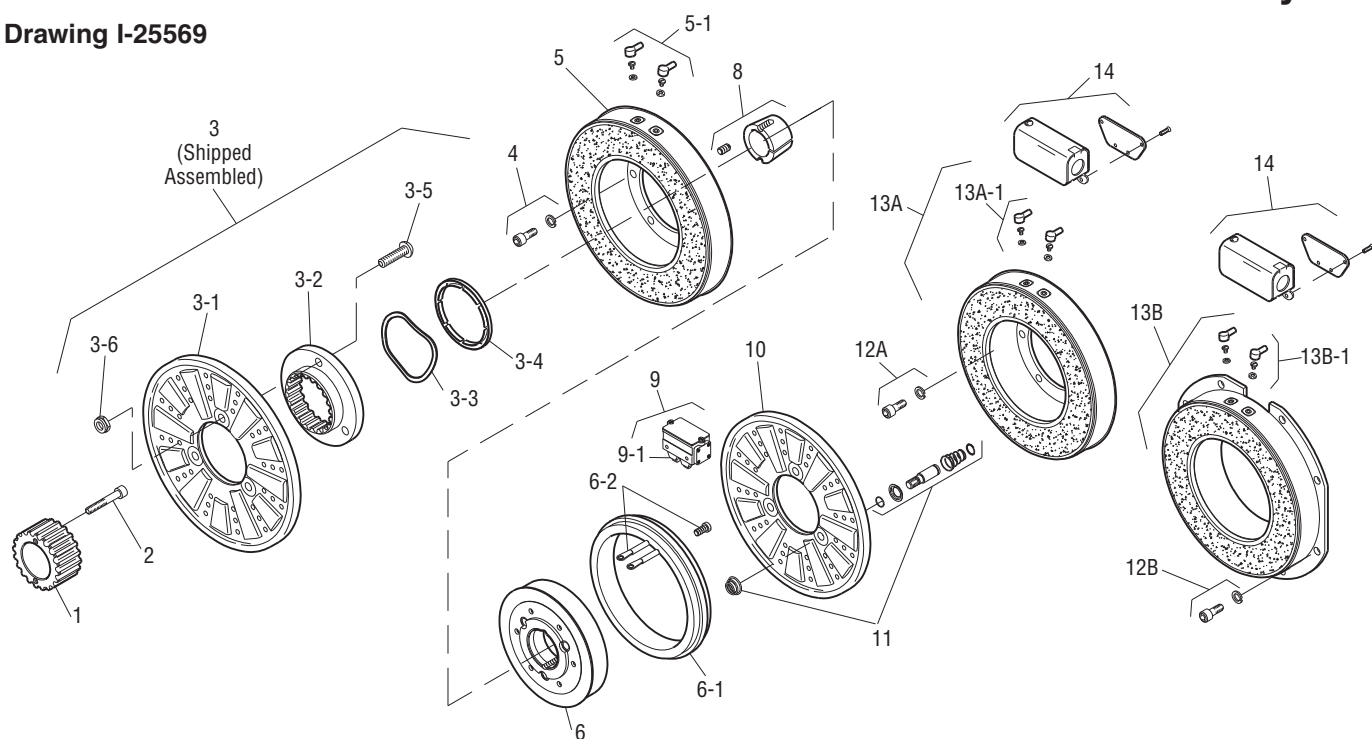

Item	Description	Part Number	Qty.
1	Splined Hub	540-0146	1
2	Mounting Accessory	5201-101-001	1
3	Armature Accessory	5321-111-001	1
3-1	Armature	5321-111-022	1
3-2	Armature Adapter	104-0008	1
3-3	Autogap Spring	808-0054	1
3-4	Retainer Ring	748-0373	1
3-5	Buttonhead Screw	797-0272	3
3-6	Locknut	661-0004	3
4	Mounting Accessory	5321-101-001	1
5	Magnet		1
	6 Volt	5301-631-002	
	24 Volt	5301-631-004	
	90 Volt	5301-631-005	
5-1	Terminal Accessory	5311-101-001	1
6	Magnet Hub		1
	Right Hand	5301-541-002	
	Left Hand (shown)	5301-541-001	
6-1	Collector Ring	5301-749-001	1
6-2	Collector Ring Accessory	5301-101-002	1
8	Bushing*	180-0131 to 180-0149	1
9	Brushholder	5300-178-001	1
9-1	Brush	176-0001	4
10	Armature	5301-111-018	1
11	Autogap Accessory	5201-101-008	3
12A	Mounting Accessory - I.M.	5321-101-001	1
12B	Mounting Accessory - O.M.	5321-101-002	1

Item	Description	Part Number	Qty.
13A	Magnet - Inside Mounted		1
	6 Volt	5311-631-002	
	24 Volt	5311-631-003	
	90 Volt	5311-631-004	
13A-1	Terminal Accessory	5311-101-001	1
13B	Magnet Hub - Outside Mounted		1
	6 Volt	5311-631-007	
	24 Volt	5311-631-009	
	90 Volt	5311-631-008	
13B-1	Terminal Accessory	5311-101-001	1
14	Conduit Box	5200-101-011	1

### How to Order:

1. Specify Voltage for Item 5 and Item 13A or 13B.
2. Specify left hand or right hand hub for Item 6. Bushing enters from magnet side for L.H. hub and from hub side for R.H. hub.
3. Specify Bore Size for Item 8.
4. Specify Inside Mounted for Items 12A and 13A or Outside Mounted for Items 12B and 13B.
5. See Controls Section.

### Example:

PCB-825 Clutch Brake per I-25569 - 90 Volt, Left Hand hub, 1" Bore, Inside Mounted

These units meet the standards of UL508 and are listed under guide card #NMTR2, file #59164. These units are CSA certified under file #LR11543

\*See page 252 for specific part numbers.

Refer to Service Manual P-205.

# Clutch/Brake

## PCB-1000 Normal Duty



See page 252 for details on Bushings.

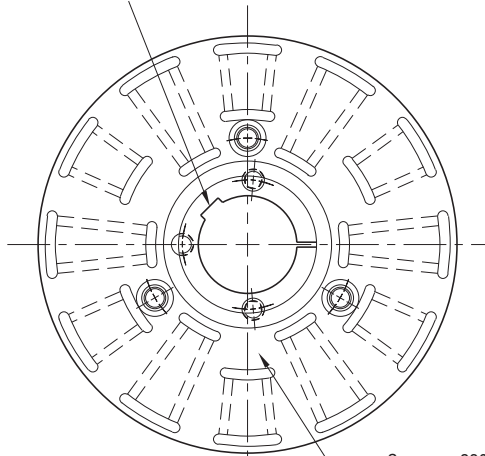

**ARMATURE VIEW**

See page 230 for details on Drive Pin mountings.

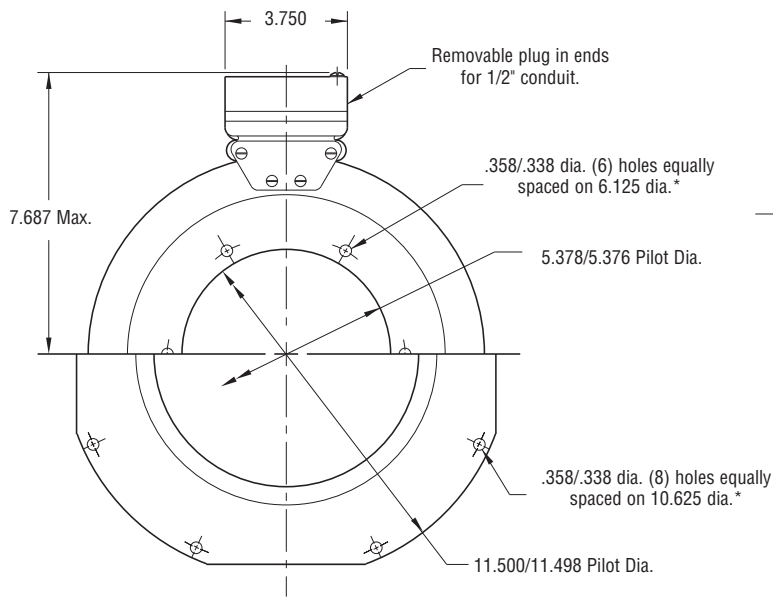

**MAGNET VIEW  
(Inside & Outside Mounted)**

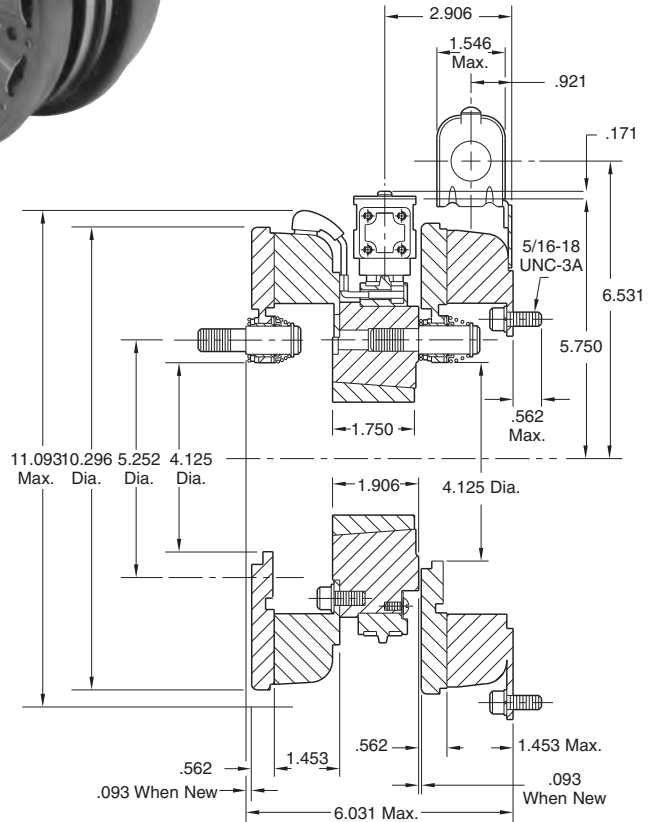

\* Mounting holes are within .010 of true position relative to pilot diameter.

### Customer Shall Maintain:

1. Concentricity of brake mounting pilot diameter with mounting shaft within .010 T.I.R.
2. Squareness of brake magnet mounting face with mounting shaft within .006 T.I.R. measured at magnet mounting bolt circle.



Shaft Size	.500 – 2.500
Static Torque	240 lb. ft.
Maximum Speed	3,600 rpm
Standard Voltage	D.C. 6, 24, 90

All dimensions are nominal unless otherwise noted.

Information on inertia and weights begins on page 239. Coil data is on pages 250 and 251.

## PCB-1000 Normal Duty

Drawing I-25588

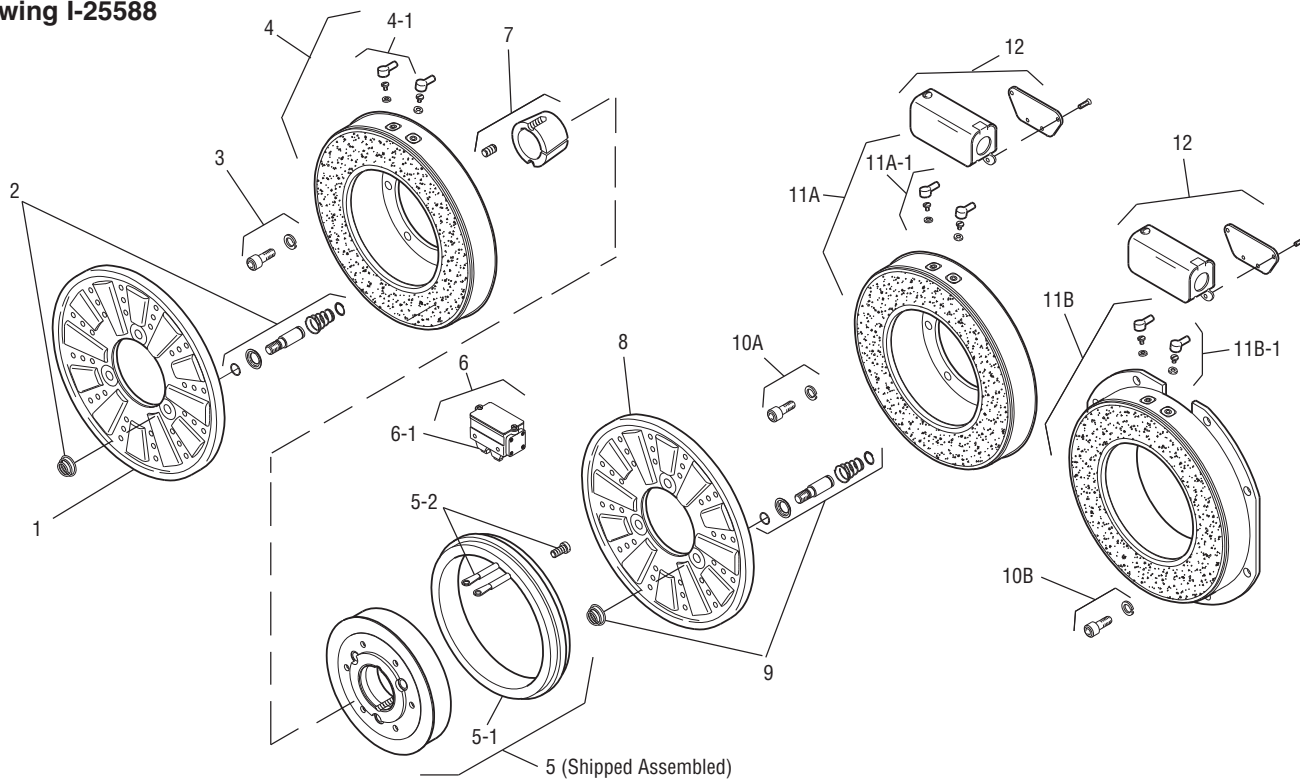

Item	Description	Part Number	Qty.
1	Armature	5302-111-013	1
2	Autogap Accessory	5201-101-008	3
3	Mounting Accessory	5321-101-001	1
4	Magnet		1
	6 Volt	5302-631-003	
	24 Volt	5302-631-014	
	90 Volt	5302-631-005	
4-1	Terminal Accessory	5311-101-001	1
5	Magnet Hub		1
	Left Hand (shown)	5302-541-001	
	Right Hand	5302-541-002	
5-1	Collector Ring	5301-749-001	1
5-2	Collector Ring Assembly	5302-101-002	1
6	Brushholder	5300-178-001	1
6-1	Brush	176-0001	4
7	Bushing*		1
	1/2" to 2-1/2" Bore	180-0185 to 180-0217	
8	Armature	5302-111-013	1
9	Autogap Accessory	5201-101-008	3
10A	Mounting Accessory - I.M.	5321-101-001	1
10B	Mounting Accessory - O.M.	5321-101-002	2
11A	Magnet - Inside Mounted		1
	6 Volt	5312-631-004	
	24 Volt	5312-631-005	
	90 Volt	5312-631-006	

Item	Description	Part Number	Qty.
11A-1	Terminal Accessory	5311-101-001	1
11B	Magnet - Outside Mounted		1
	6 Volt	5312-631-011	
	24 Volt	5312-631-013	
	90 Volt	5312-631-012	
11B-1	Terminal Accessory	5311-101-001	1
12	Conduit Box	5200-101-011	1

### How to Order:

1. Specify Voltage for Item 4 and Item 11A or 11B.
2. Specify left hand or right hand hub for Item 5. Bushing enters from magnet side for L.H. hub and from hub side for R.H.
3. Specify Bore Size for Item 7.
4. Specify Inside Mounted for Items 10A and 11A or Outside Mounted for Items 10B and 11B.
5. See Controls Section.

### Example:

PCB-1000 Clutch Brake per I-25588 -  
90 Volt, Left Hand hub, 1-1/2" Bore, Inside Mounted

These units meet standards set forth in UL508 and are listed under guide card #NMTR2, file #59164. These units are CSA certified under file #LR11543

\*See page 252 for specific part numbers.

Refer to Service Manual P-205.

# Clutch/Brake

## PCB-1000 Heavy Duty



.397/.388 dia. (3) holes (hub) equally spaced on 3.187 dia. and within .003 of true position in relation to 4.001/3.999 pilot dia.

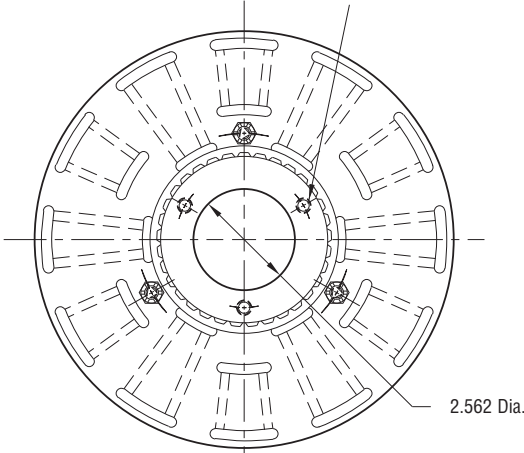

**ARMATURE VIEW**

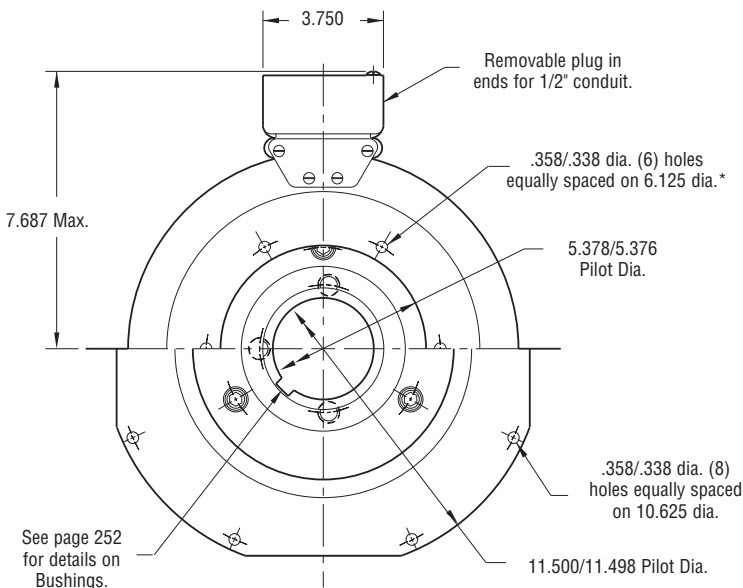

**MAGNET VIEW**  
(Inside & Outside Mounted)

**Customer Shall Maintain:**

1. Concentricity of brake magnet mounting pilot diameter with mounting shaft within .010 T.I.R.
2. Squareness of brake magnet mounting face with magnet mounting shaft within .006 T.I.R.
3. Splined hub pilot diameter to be concentric with splined armature center of rotation within .010 T.I.R.

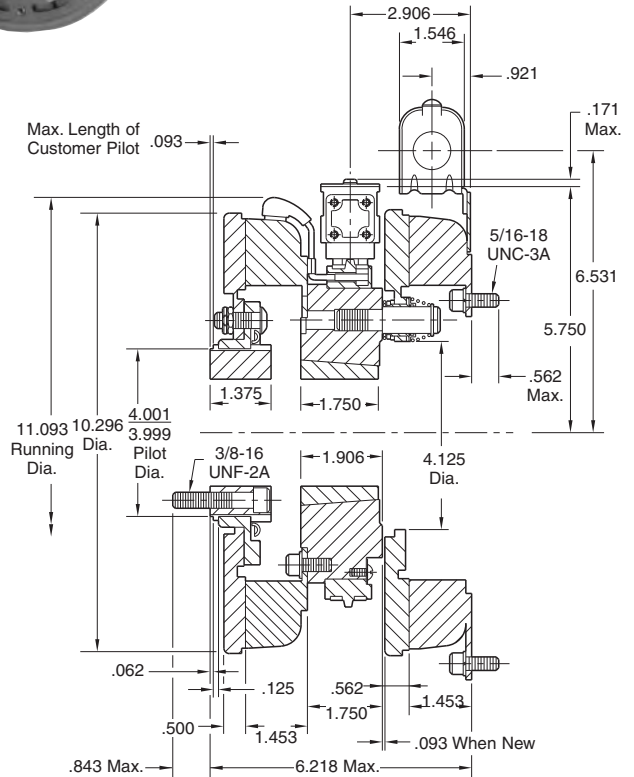

\* Mounting holes are within .010 of true position relative to pilot diameter.

Shaft Size	.500 – 2.500
Static Torque	240 lb. ft.
Maximum Speed	3,600 rpm
Standard Voltage	D.C. 6, 24, 90

All dimensions are nominal unless otherwise noted.

Information on inertia and weights begins on page 239. Coil data is on pages 250 and 251.



## PCB-1000 Heavy Duty

Drawing I-25589

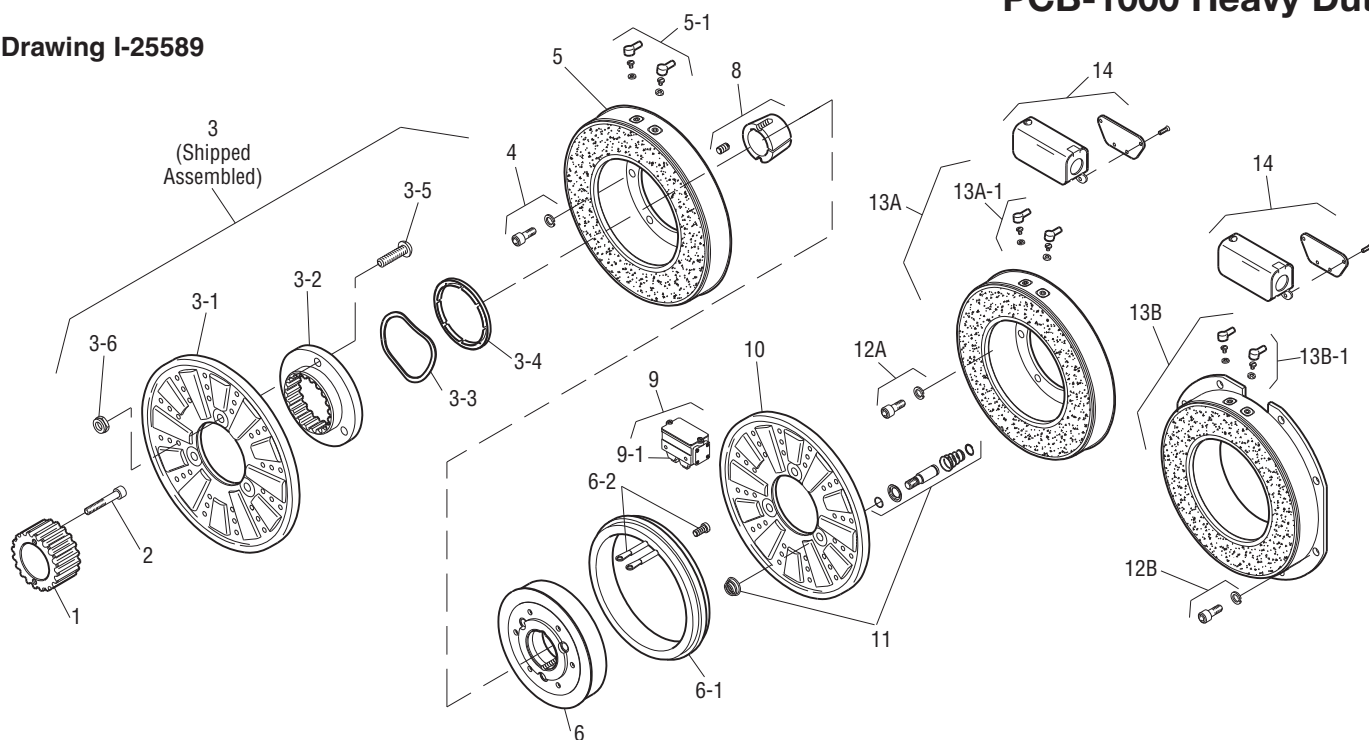

Item	Description	Part Number	Qty.
1	Splined Hub	540-0147	1
2	Mounting Accessory	5202-101-001	1
3	Armature Accessory	5322-111-002	1
3-1	Armature	5322-111-036	1
3-2	Armature Adapter	104-0009	1
3-3	Autogap Spring	808-0061	1
3-4	Retainer Ring	748-0374	1
3-5	Buttonhead Screw	797-0272	3
3-6	Locknut	661-0004	3
4	Mounting Accessory	5321-101-001	1
5	Magnet		1
	6 Volt	5302-631-003	
	24 Volt	5302-631-014	
	90 Volt	5302-631-005	
5-1	Terminal Accessory	5311-101-001	1
6	Magnet Hub		1
	Right Hand	5302-541-002	
	Left Hand (shown)	5302-541-001	
6-1	Collector Ring	5301-749-001	1
6-2	Collector Ring Accessory	5301-101-002	1
8	Bushing*	180-0185 to 180-0217	1
9	Brushholder	5300-178-001	1
9-1	Brush	176-0001	4
10	Armature	5302-111-013	1
11	Autogap Accessory	5201-101-008	3
12A	Mounting Accessory - I.M.	5321-101-001	1
12B	Mounting Accessory - O.M.	5321-101-002	2

Item	Description	Part Number	Qty.
13A	Magnet - Inside Mounted		1
	6 Volt	5312-631-004	
	24 Volt	5312-631-005	
	90 Volt	5312-631-006	
13A-1	Terminal Accessory	5311-101-001	1
13B	Magnet Hub - Outside Mounted		1
	6 Volt	5312-631-011	
	24 Volt	5312-631-013	
	90 Volt	5312-631-012	
13B-1	Terminal Accessory	5311-101-001	1
14	Conduit Box	5200-101-011	1

### How to Order:

1. Specify Voltage for Item 5 and Item 13A or 13B.
2. Specify left hand or right hand hub for Item 6. Bushing enters from magnet side for L.H. hub and from hub side for R.H. hub.
3. Specify Bore Size for Item 7.
4. Specify Inside Mounted for Items 12A and 13A or Outside Mounted for Item 12B and 13B.
5. See Controls Section.

### Example:

PCB-1000 Clutch Brake per I-25589 - 90 Volt, Left Hand hub, 1-1/2" Bore, Inside Mounted

These units meet the standards of UL508 and are listed under guide card #NMTR2, file #59164. These units are CSA certified under file #LR11543.

\*See page 252 for specific part numbers.

Refer to Service Manual P-205.

# Clutch/Brake

## PCB-1225/1000 Normal Duty



See page 252 for details on Bushings.

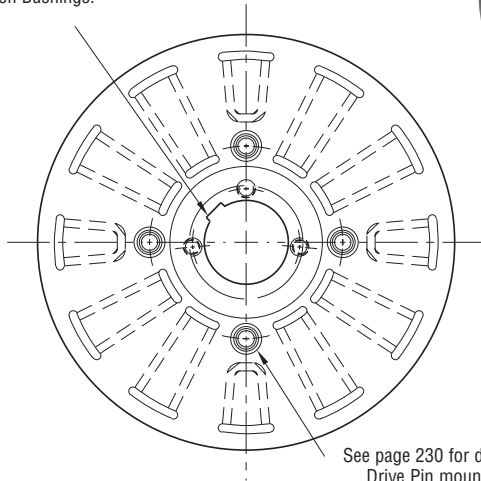

**ARMATURE VIEW**

See page 230 for details on Drive Pin mountings.

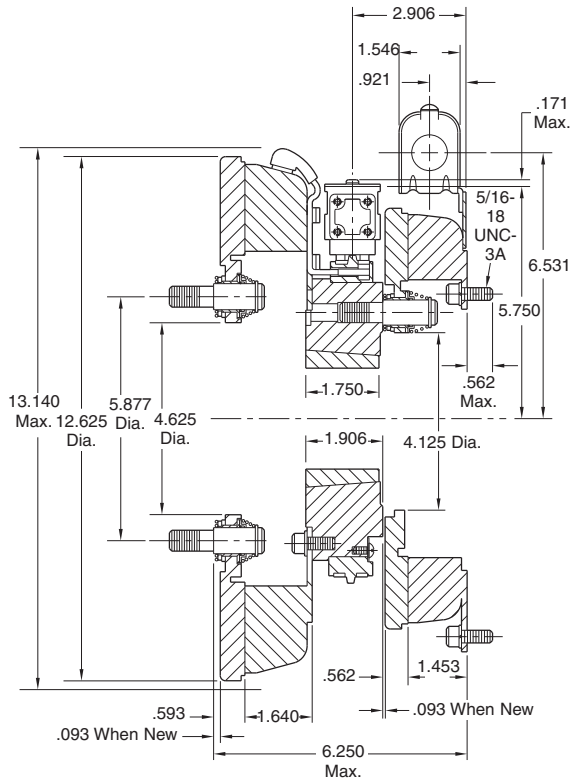

\* Mounting holes are within .010 of true position relative to pilot diameter.

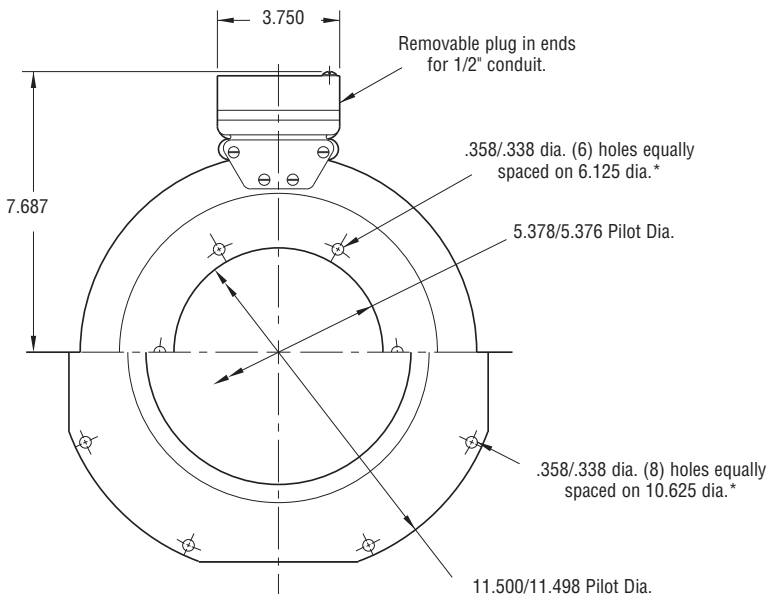

**MAGNET VIEW**  
(Inside & Outside Mounted)

### Customer Shall Maintain:

1. Concentricity of brake mounting pilot diameter with mounting shaft within .010 T.I.R.
2. Squareness of brake magnet mounting face with mounting shaft within .006 T.I.R. measured at magnet mounting bolt circle.

Shaft Size	.500 – 2.500
Static Torque Clutch	465 lb. ft.
Static Torque Brake	240 lb. ft.
Maximum Speed	3,000 rpm
Standard Voltage	D.C. 6, 24, 90

All dimensions are nominal unless otherwise noted.

Information on inertia and weights begins on page 239. Coil data is on pages 250 and 251.



## PCB-1225/1000 Normal Duty

Drawing I-25610

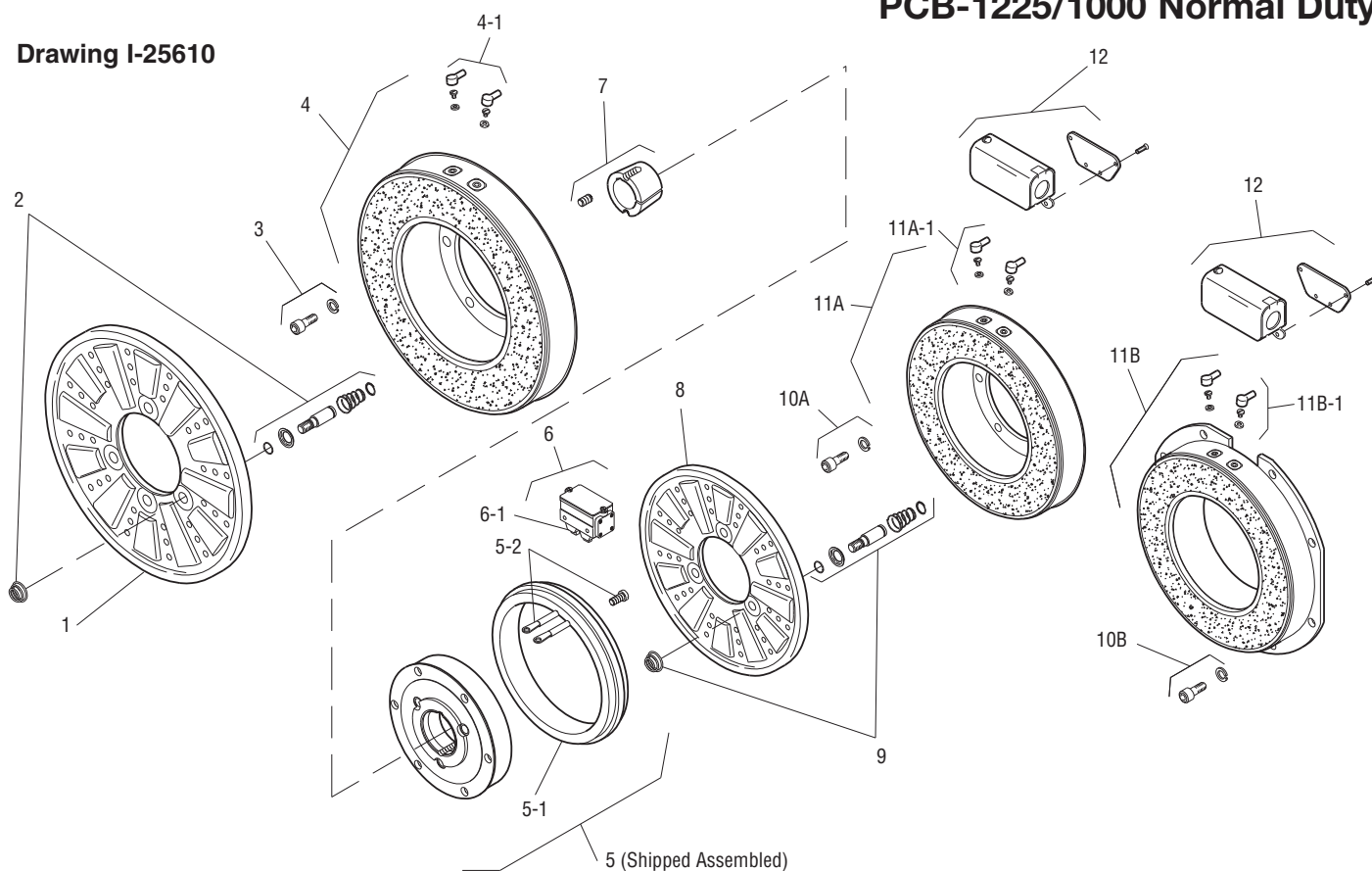

Item	Description	Part Number	Qty.
1	Armature	5303-111-009	1
2	Autogap Accessory	5201-101-008	4
3	Mounting Accessory	5321-101-001	1
4	Magnet		1
	6 Volt	5333-631-008	
	90 Volt	5333-631-009	
	†90 Volt LK Facing	5333-631-013	
4-1	Terminal Accessory	5311-101-001	1
5	Magnet Hub		1
	Left Hand (shown)	5302-541-004	
	Right Hand	5302-541-005	
5-1	Collector Ring	5301-749-001	1
5-2	Collector Ring Accessory	5303-101-004	1
6	Brushholder	5300-178-001	1
6-1	Brush	176-0001	4
7	Bushing*		1
	1/2" to 2-1/2" Bore	180-0185 to 180-0217	
8	Armature	5302-111-013	1
9	Autogap Accessory	5201-101-008	3
10A	Mounting Accessory - I.M.	5321-101-001	1
10B	Mounting Accessory - O.M.	5321-101-002	2
11A	Magnet - Inside Mounted		1
	6 Volt	5312-631-004	
	24 Volt	5312-631-005	
	90 Volt	5312-631-006	

Item	Description	Part Number	Qty.
11A-1	Terminal Accessory	5311-101-001	1
11B	Magnet - Outside Mounted		1
	6 Volt	5312-631-011	
	24 Volt	5312-631-013	
	90 Volt	5312-631-012	
11B-1	Terminal Accessory	5311-101-001	1
12	Conduit Box	5200-101-011	1

### How to Order:

1. Specify Voltage for Item 4 and Item 11A or 11B.
2. Specify left hand or right hand hub for Item 5. Bushing enters from magnet side for L.H. hub and from hub side for R.H.
3. Specify Bore Size for Item 7.
4. Specify Inside Mounted for Items 10A and 11A or Outside Mounted for Items 10B and 11B.
5. See Controls Section.

### Example:

PCB-1225/1000 Clutch Brake per I-25610 - 90 Volt, Left Hand hub, 1-1/2" Bore, Inside Mounted

These units meet the standards of UL508 and are listed under guide card #NMTR2, file #59164. These units are CSA certified under file #LR11543.

\*See page 252 for specific part numbers.

Refer to Service Manual P-214.

†Optional LK facing available. For more information, see page 232.

# Clutch/Brake

## PCB-1225/1000 Heavy Duty



.397/.388 dia. (8) holes (hub) equally spaced on (3.625) dia. and within .003 of true position in relation to 4.313/4.311 pilot dia.

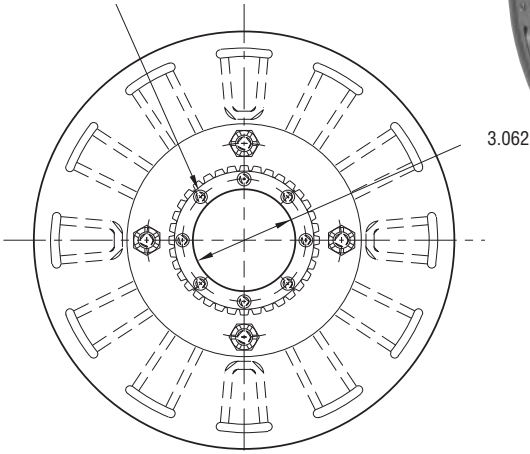

**ARMATURE VIEW**

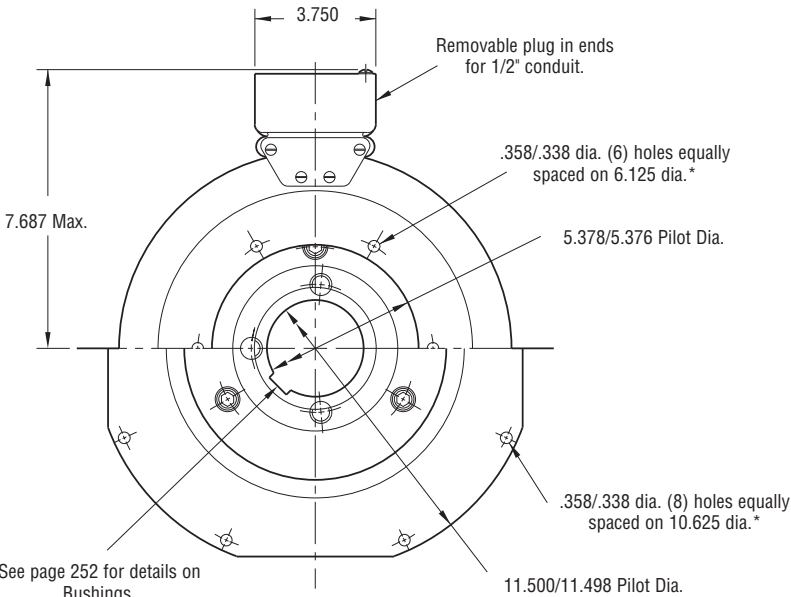

**MAGNET VIEW**

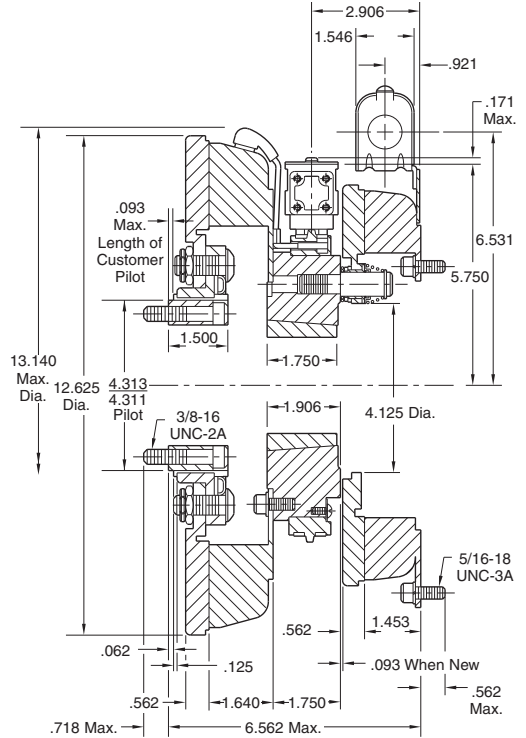

\* Mounting holes are within .010 of true position relative to pilot diameter.

### Customer Shall Maintain:

1. Concentricity of brake magnet mounting pilot diameter to mounting shaft within .010 T.I.R.
2. Squareness of brake magnet mounting face to magnet mounting shaft within .006 T.I.R.
3. Splined hub pilot diameter to be concentric with splined armature center of rotation within .010 T.I.R.

Shaft Size	.500 – 2.500
Static Torque Clutch	465 lb. ft.
Static Torque Brake	240 lb. ft.
Maximum Speed	3,000 rpm
Standard Voltage	D.C. 6, 24, 90

All dimensions are nominal unless otherwise noted.

Information on inertia and weights begins on page 239. Coil data is on pages 250 and 251.





## PCB-1225/1000 Heavy Duty

Drawing I-25611

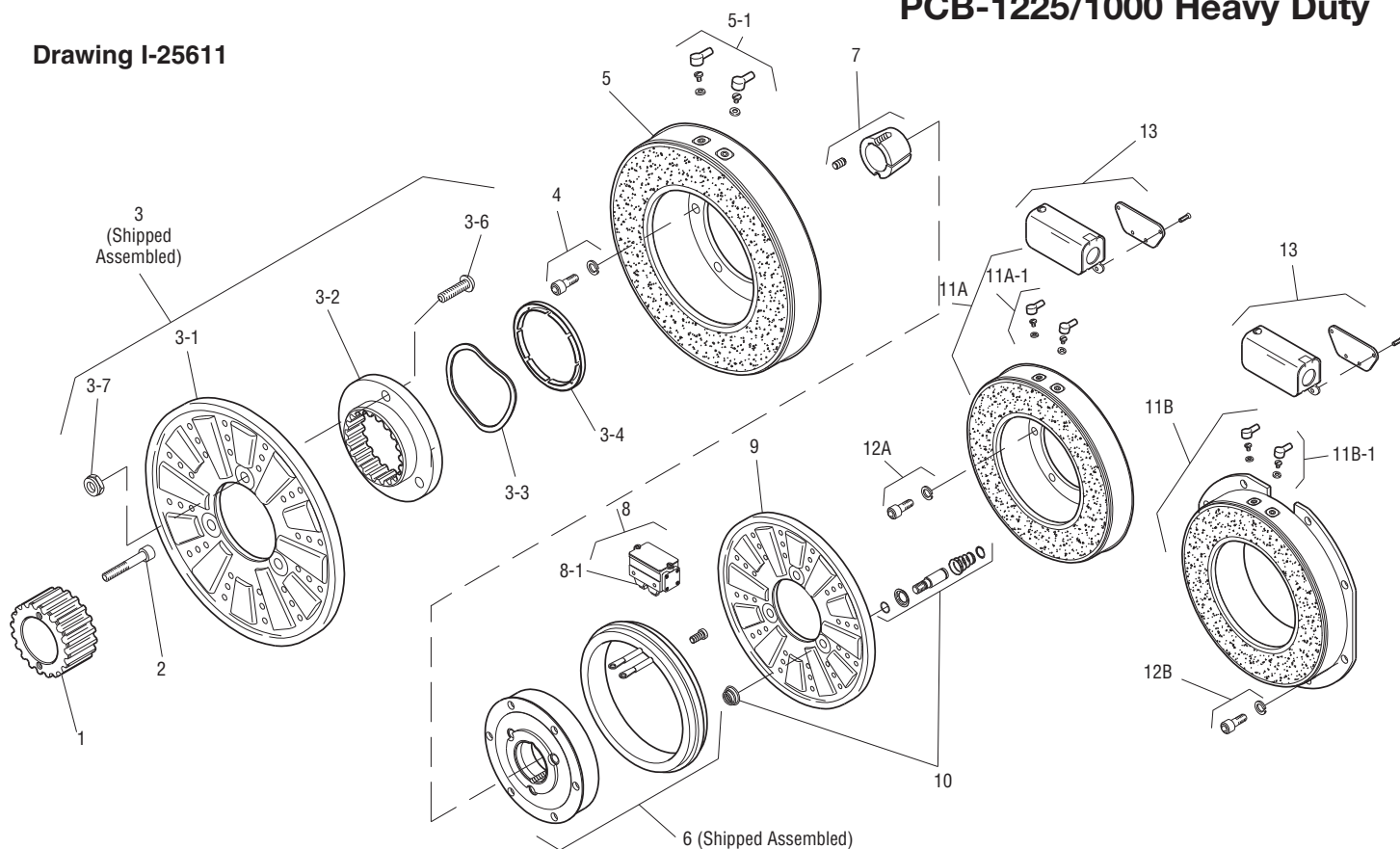

Item	Description	Part Number	Qty.
1	Splined Hub	540-0148	1
2	Mounting Accessory	5202-101-001	1
3	Armature Assembly	5323-111-001	1
3-1	Armature	5323-111-034	1
3-2	Splined Armature Adapter	104-0010	1
3-3	Autogap Spring	808-0044	1
3-4	Retainer Ring	748-0370	1
3-6	Buttonhead Screw	797-0281	4
3-7	Locknut	661-0005	4
4	Mounting Accessory	5321-101-001	1
5	Magnet Assembly		1
	6 Volt	5333-631-008	
	90 Volt	5333-631-009	
	†90 Volt LK Facing	5333-631-013	
5-1	Terminal Accessory	5311-101-001	1
6	Hub Assembly		
	Left Hand (shown)	5302-541-004	1
	Right Hand	5302-541-005	1
7	Bushing*	180-0185 to 180-0217	1
8	Brushholder	5300-178-001	1
8-1	Brush	176-0001	4
9	Armature Assembly	5302-111-013	1
10	Autogap Accessory	5201-101-008	3
11A	Magnet I.M.		1
	6 Volt	5312-631-004	
	24 Volt	5312-631-005	
	90 Volt	5312-631-006	
11A-1	Terminal Accessory	5311-101-001	1

Item	Description	Part Number	Qty.
11B	Magnet - Outside Mounted		1
	6 Volt	5312-631-011	
	24 Volt	5312-631-013	
	90 Volt	5312-631-012	
11B-1	Terminal Accessory	5311-101-001	1
12A	Mounting Accessory I.M.	5321-101-001	1
12B	Mounting Accessory O.M.	5321-101-002	2
13	Conduit Box	5200-101-011	1

### How to Order:

1. Specify Voltage for Item 5 and Item 11A or 11B.
2. Specify left hand or right hand hub for Item 6. Bushing enters from magnet side for L.H. hub and from hub side for R.H.
3. Specify Bore Size for Item 7.
4. Specify Inside Mounted for Items 11A and 12A or Outside Mounted for Items 11B and 12B.
5. See Controls Section.

### Example:

PCB-1225/1000 Clutch Brake per I-25611- 90 Volt, Left Hand hub, 1-1/2" Bore, Inside Mounted

These units meet the standards of UL508 and are listed under guide card #NMTRs, file #59164. These units are CSA certified under file #LR11543.

\*See page 252 for specific part numbers.

Refer to Service Manual P-214.

†Optional LK facing available. For more information, see page 232.

# Clutch/Brake

## PCB-1225 Normal Duty



See page 252 for details on Bushings.

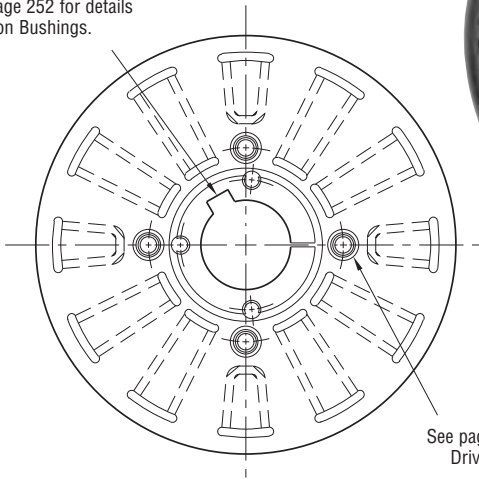

**ARMATURE VIEW**

See page 230 for details on Drive Pin mountings.

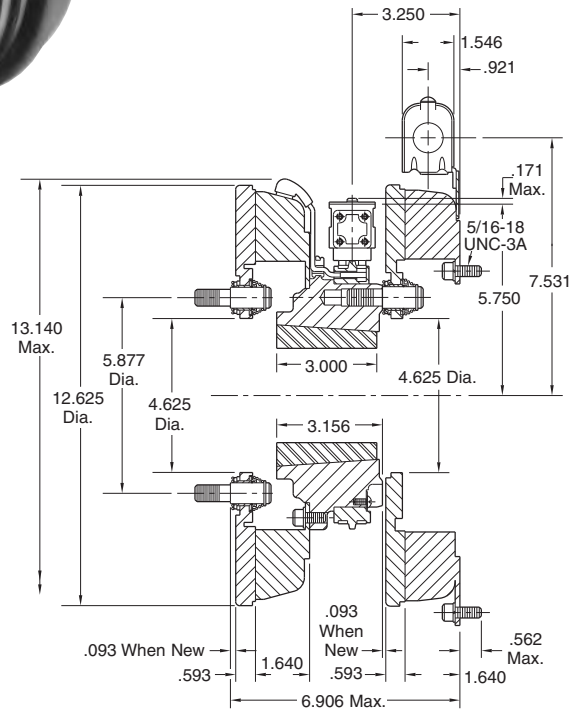

\* Mounting holes are within .010 of true position relative to pilot diameter.

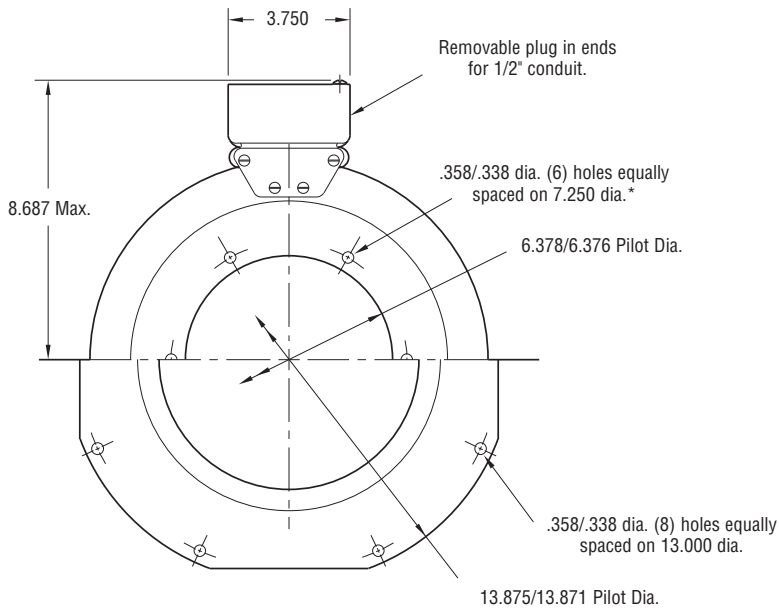

**MAGNET VIEW**  
(Inside & Outside Mounted)

### Customer Shall Maintain:

1. Concentricity of brake mounting pilot diameter with mounting shaft within .010 T.I.R.
2. Squareness of brake magnet mounting face with mounting shaft within .006 T.I.R. measured at magnet mounting bolt circle.

Shaft Size	.937 – 3.000
Static Torque	465 lb. ft.
Maximum Speed	3,000 rpm
Standard Voltage	D.C. 6, 24, 90

All dimensions are nominal unless otherwise noted.

Information on inertia and weights begins on page 239. Coil data is on pages 250 and 251.



## PCB-1225 Normal Duty

Drawing I-25608

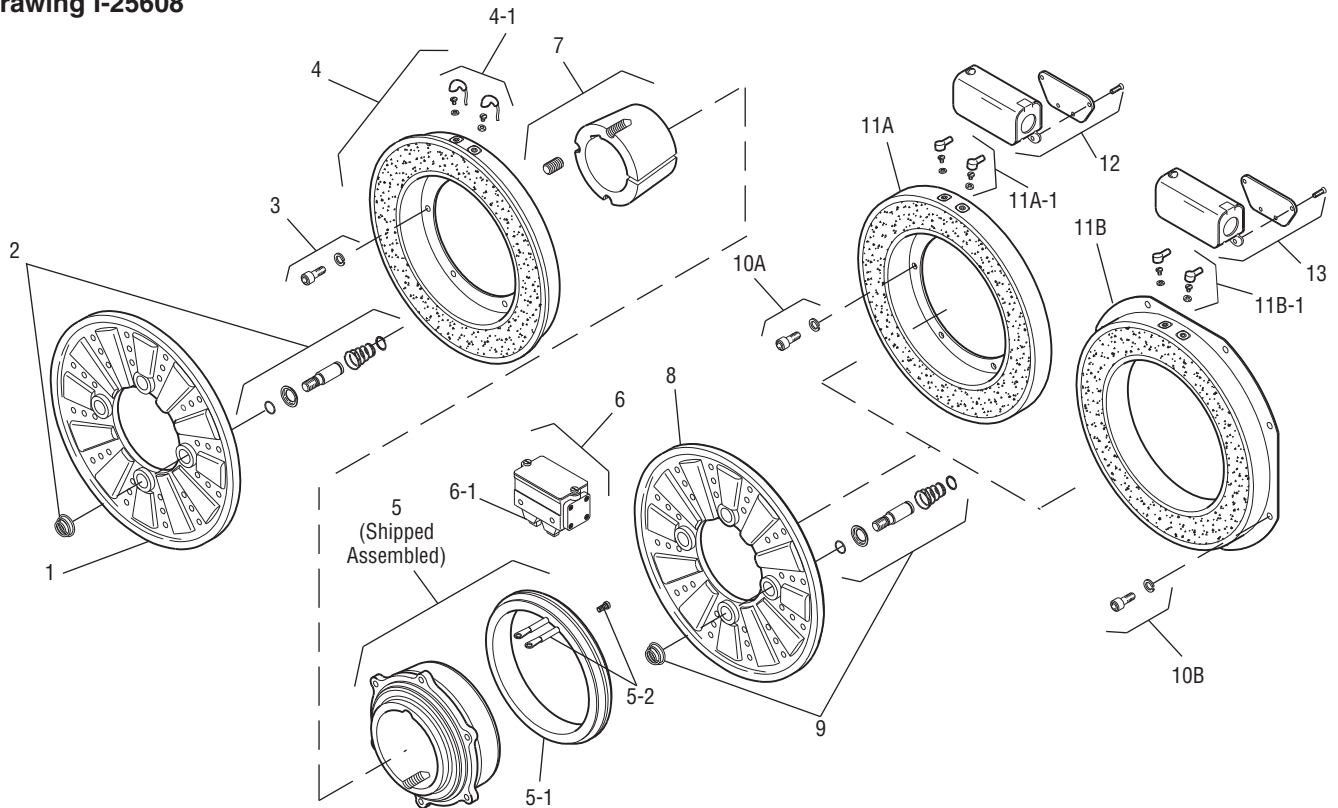

Item	Description	Part Number	Qty.
1	Armature	5303-111-009	1
2	Autogap Accessory	5201-101-008	4
3	Mounting Accessory	5321-101-001	1
4	Magnet		1
	6 Volt	5303-631-005	
	24 Volt	5303-631-007	
	90 Volt	5303-631-008	
4-1	Terminal Accessory	5311-101-001	1
5	Magnet Hub		1
	Left Hand (shown)	5303-541-001	
	Right Hand	5303-541-002	
5-1	Collector Ring	5301-749-001	1
5-2	Collector Ring Assembly	5303-101-004	1
6	Brushholder	5300-178-001	1
6-1	Brush	176-0001	4
7	Bushing*		1
	15/16" to 3" Bore	180-0262 to 180-0295	
8	Armature	5303-111-009	1
9	Autogap Accessory	5201-101-008	4
10A	Mounting Accessory - I.M.	5321-101-001	1
10B	Mounting Accessory - O.M.	5321-101-002	2
11A	Magnet - Inside Mounted		1
	6 Volt	5313-631-005	
	24 Volt	5313-631-006	
	90 Volt	5313-631-007	

Item	Description	Part Number	Qty.
11A-1	Terminal Accessory	5311-101-001	1
11B	Magnet - Outside Mounted		1
	6 Volt	5313-631-010	
	24 Volt	5313-631-012	
	90 Volt	5313-631-011	
11B-1	Terminal Accessory	5311-101-001	1
12	Conduit Box	5200-101-011	2

### How to Order:

1. Specify Voltage for Item 4 and Item 11A or 11B.
2. Specify left hand or right hand hub for Item 5. Bushing enters from magnet side for L.H. hub and from hub side for R.H.
3. Specify Bore Size for Item 7.
4. Specify Inside Mounted for Items 10A and 11A or Outside Mounted for Items 10B and 11B.
5. See Controls Section.

### Example:

PCB-1225 Clutch Brake per I-25608 -  
90 Volt, Left hand hub, 2" Bore,  
Inside Mounted.

These units meet the standards of UL508 and are listed under guide card #NMTR2, file #59164. These units are CSA certified under file #LR11543.

\*See page 252 for specific part numbers.

Refer to Service Manual P-205.

# Clutch/Brake

## PCB-1225 Heavy Duty



(.397/.388) dia. (8) holes (hub) equally spaced on (3.625) dia. and within .003 of true position in relation to (4.313/4.311) pilot dia.

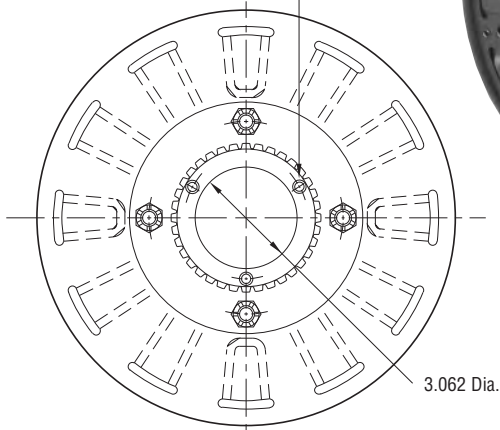

**ARMATURE VIEW**

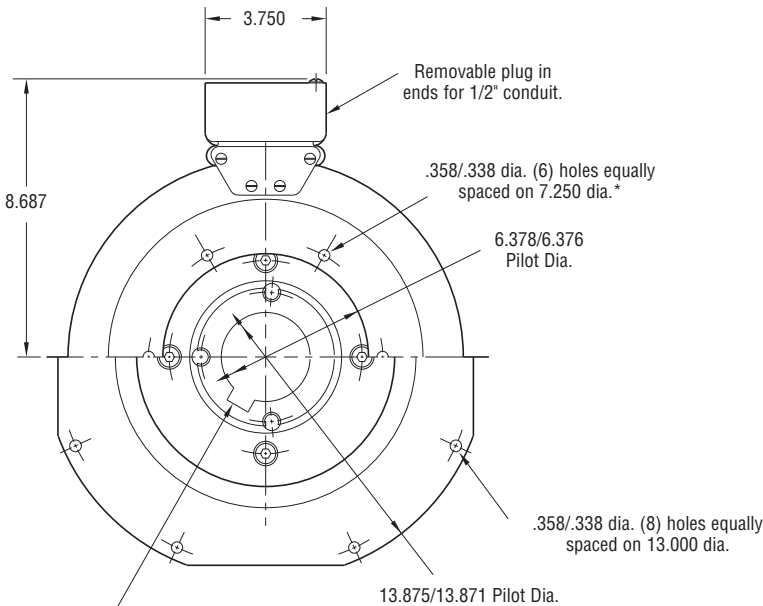

See page 252 for details on Bushings.

**MAGNET VIEW  
(Inside & Outside Mounted)**

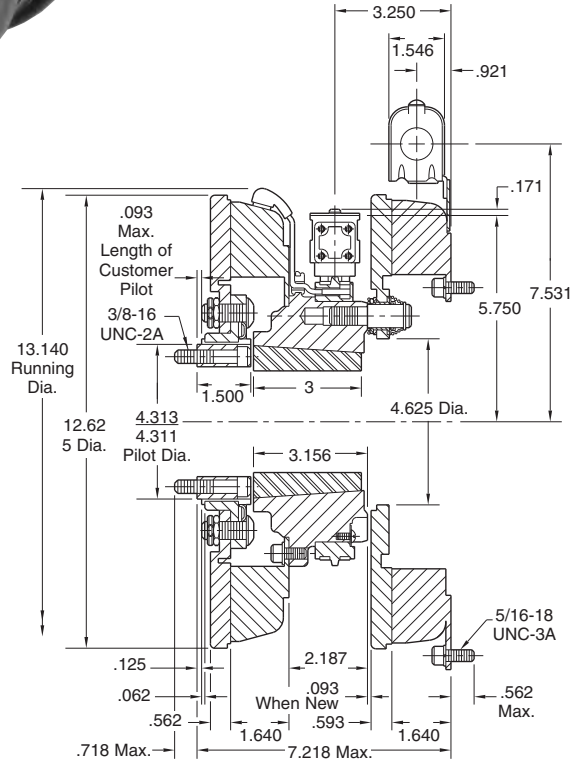

\* Mounting holes are within .010 of true position relative to pilot diameter.

Shaft Size	.937 – 3.000
Static Torque	465 lb. ft.
Maximum Speed	3,000 rpm
Standard Voltage	D.C. 6, 24, 90

All dimensions are nominal unless otherwise noted.

Information on inertia and weights begins on page 239. Coil data is on pages 250 and 251.



## PCB-1225 Heavy Duty

Drawing I-25609

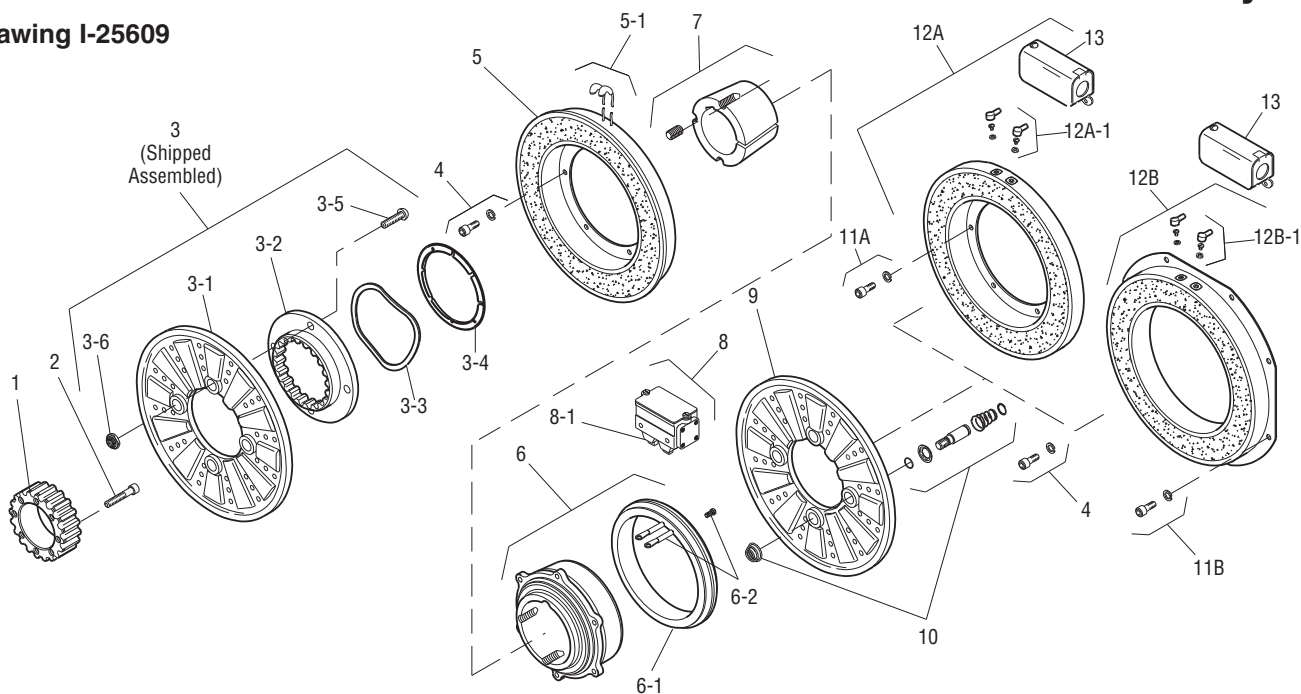

Item	Description	Part Number	Qty.
1	Splined Hub	540-0148	1
2	Mounting Accessory	5202-101-001	1
3	Armature Assembly	5323-111-001	1
3-1	Armature	5323-111-034	1
3-2	Armature Adapter	104-0010	1
3-3	Autogap Spring	808-0044	1
3-4	Retainer Ring	748-0370	1
3-5	Buttonhead Screw	797-0281	3
3-6	Locknut	661-0005	3
4	Mounting Accessory	5321-101-001	1
5	Magnet		1
	6 Volt	5303-631-005	
	24 Volt	5303-631-007	
	90 Volt	5303-631-008	
5-1	Terminal Accessory	5311-101-001	1
6	Magnet Hub		1
	Right Hand	5303-541-002	
	Left Hand (shown)	5303-541-001	
6-1	Collector Ring	5301-749-001	1
6-2	Collector Ring Accessory	5303-101-004	1
7	Bushing*	180-0262 to 180-0295	1
8	Brushholder	5300-178-001	1
8-1	Brush	176-0001	4
9	Armature	5303-111-009	1
10	Autogap Accessory	5201-101-008	4
11A	Mounting Accessory		
	Inside Mounted	5321-101-001	1
11B	Mounting Accessory		
	Outside Mounted	5321-101-002	2

Item	Description	Part Number	Qty.
12A	Magnet - Inside Mounted		1
	6 Volt	5313-631-005	
	24 Volt	5313-631-006	
	90 Volt	5313-631-007	
12A-1	Terminal Accessory	5311-101-001	1
12B	Magnet - Outside Mounted		1
	6 Volt	5313-631-010	
	24 Volt	5313-631-012	
	90 Volt	5313-631-011	
12B-1	Terminal Accessory	5311-101-001	1
13	Conduit Box	5200-101-010	1

### How to Order:

1. Specify Voltage for Item 5 and Item 12A or 12B.
2. Specify left hand or right hand hub for Item 6. Bushing enters from magnet side for L.H. hub and from hub side for R.H.
3. Specify Bore Size for Item 7.
4. Specify Inside Mounted for Items 11A and 12A or Outside Mounted for Items 11B and 12B.
5. See Controls Section.

### Example:

PCB-1225 Clutch Brake per I-25609 - 90 Volt, Left Hand hub, 2" Bore, Inside Mounted

These units meet the standards of UL508 and are listed under guide card #NMTR2, file #59164. These units are CSA certified under file #LR11543.

\*See page 252 for specific part numbers.

Refer to Service Manual P-205.

# Clutch/Brake

## PCB-1525/1225 Normal Duty



See page 252 for details on Bushings.

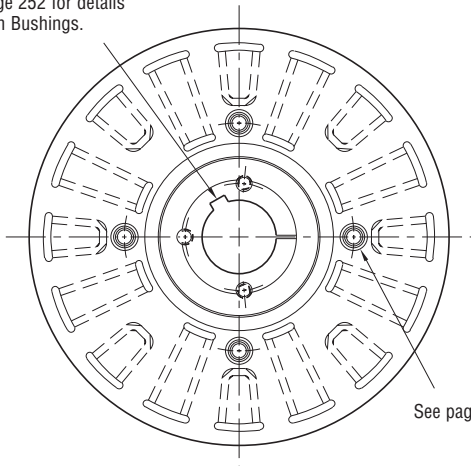

See page 230 for details on Drive Pin mountings.

**ARMATURE VIEW**

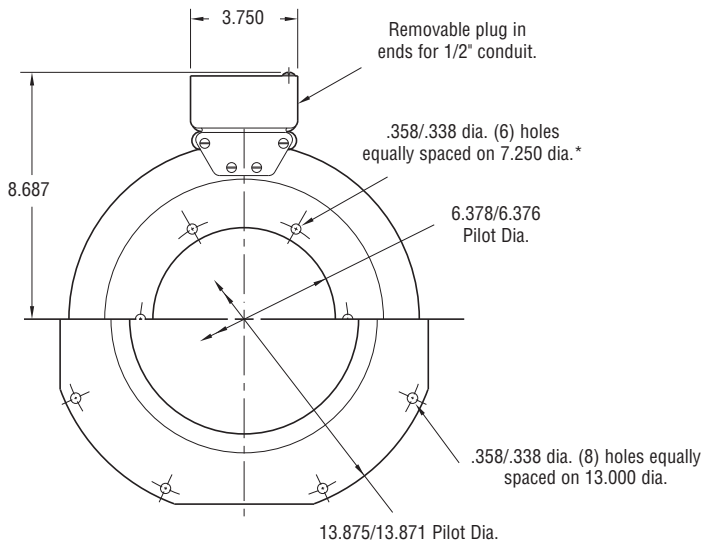

**MAGNET VIEW  
(Inside & Outside Mounted)**

### Customer Shall Maintain:

1. Concentricity of brake mounting pilot diameter with mounting shaft within .010 T.I.R.
2. Squareness of brake magnet mounting face with mounting shaft within .006 T.I.R. measured at magnet mounting bolt circle.

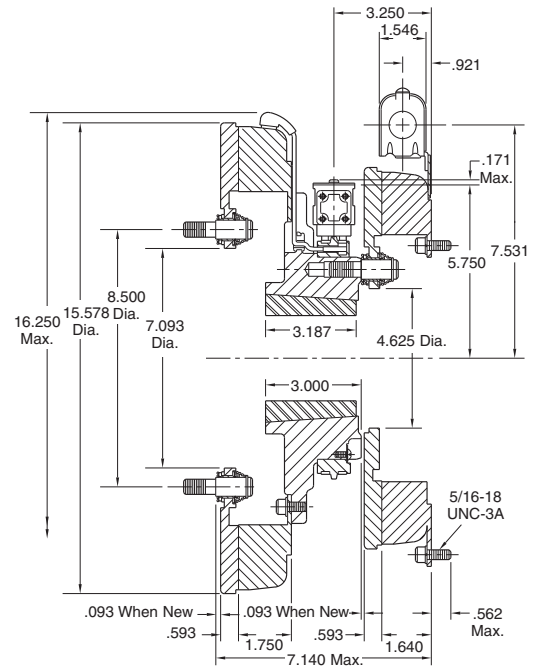

\* Mounting holes are within .010 of true position relative to pilot diameter.

Shaft Size	.937 – 3.000
Static Torque Clutch	700 lb. ft.
Static Torque Brake	465 lb. ft.
Maximum Speed	2,000 rpm
Standard Voltage	D.C. 6, 24, 90

All dimensions are nominal unless otherwise noted.

Information on inertia and weights begins on page 239. Coil data is on pages 250 and 251.



## PCB-1525/1225 Normal Duty

Drawing I-25635

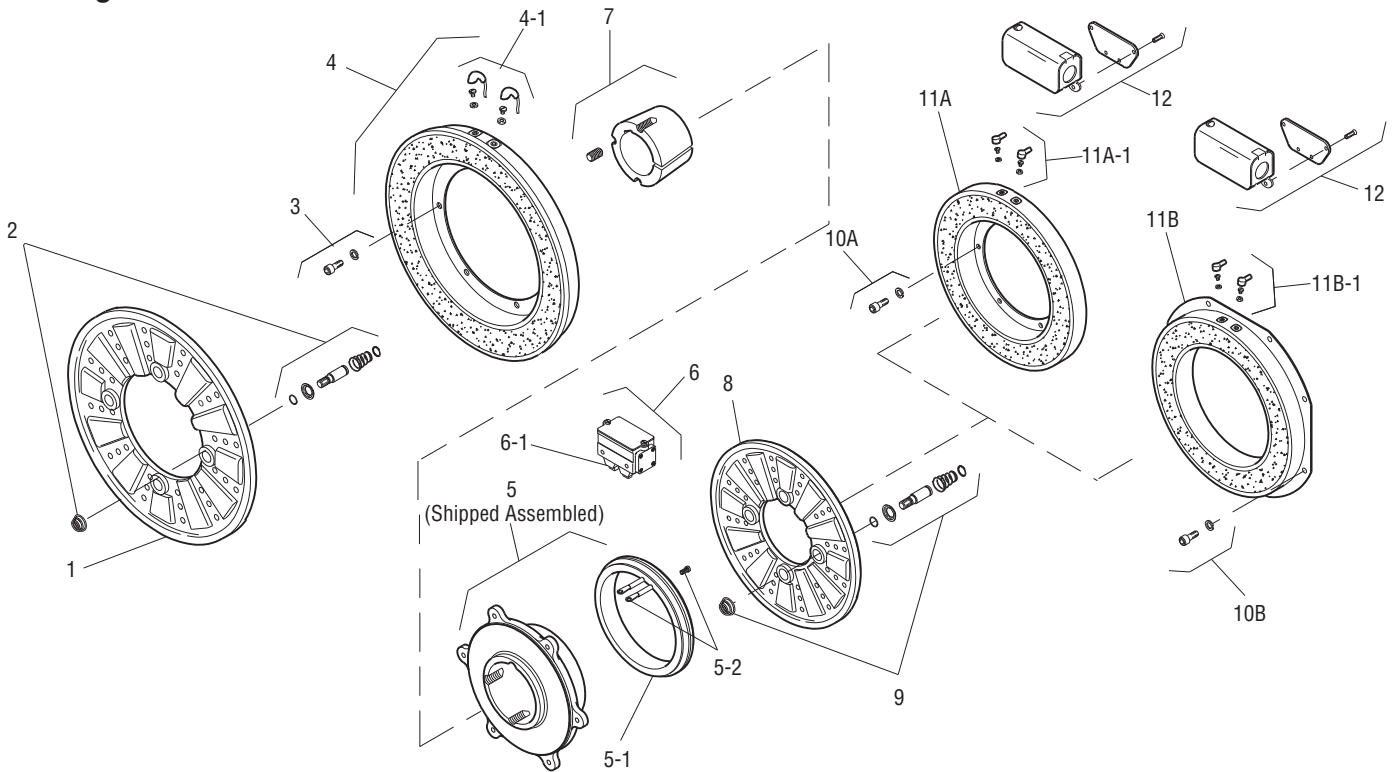

Item	Description	Part Number	Qty.
1	Armature	5304-111-004	1
2	Autogap Accessory	5201-101-008	4
3	Mounting Accessory	5321-101-001	1
4	Magnet		1
	6 Volt	5304-631-009	
	24 Volt	5304-631-011	
	90 Volt	5304-631-010	
4-1	Terminal Accessory	5311-101-001	1
5	Magnet Hub		1
	Left Hand (shown)	5304-541-001	
	Right Hand	5304-541-002	
5-1	Collector Ring	5301-749-001	1
5-2	Collector Ring Accessory	5304-101-004	1
6	Brushholder	5300-178-001	1
6-1	Brush	176-0001	4
7	Bushing*		1
	15/16" to 3" Bore	180-0262 to 180-0295	
8	Armature	5303-111-009	1
9	Autogap Accessory	5201-101-008	4
10A	Mounting Assembly - I.M.	5321-101-001	1
10B	Mounting Accessory - O.M.	5321-101-002	2
11A	Magnet - Inside Mounted		1
	6 Volt	5313-631-005	
	24 Volt	5313-631-006	
	90 Volt	5313-631-007	

Item	Description	Part Number	Qty.
11A-1	Terminal Accessory	5311-101-001	1
11B	Magnet - Outside Mounted		1
	6 Volt	5313-631-010	
	24 Volt	5313-631-012	
	90 Volt	5313-631-011	
11B-1	Terminal Accessory	5311-101-001	1
12	Conduit Box	5200-101-010	1

### How to Order:

1. Specify Voltage for Item 4 and Item 11A or 11B.
2. Specify left hand or right hand hub for Item 5. Bushing enters from magnet side for L.H. hub and from hub side for R.H.
3. Specify Bore Size for Item 7.
4. Specify Inside Mounted for Items 10A and 11A or Outside Mounted for Items 10B and 11B.
5. See Controls Section.

### Example:

PCB-1525/1225 Clutch Brake per I-25635 - 90 Volt, Left Hand hub, 2" Bore, Inside Mounted

These units meet the standards of UL508 and are listed under guide card #NMTR2, file #59164. These units are CSA certified under file #LR11543.

\*See page 252 for specific part numbers.

Refer to Service Manual P-214.

# Clutch/Brake

## PCB-1525/1225 Heavy Duty

(.397/.388) dia. (8) holes (hub) equally spaced on (3.625) dia. and within .003 of true position relative to (4.313/4.311) pilot diameter.

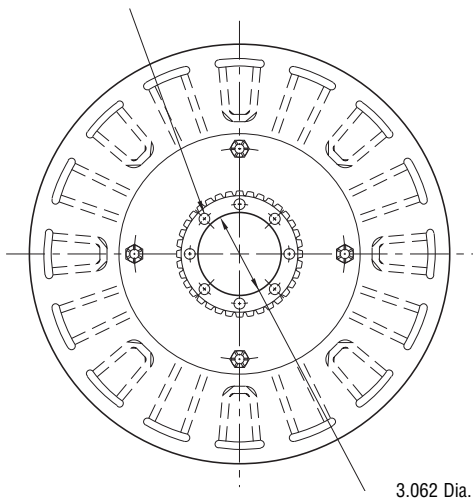

**ARMATURE VIEW**

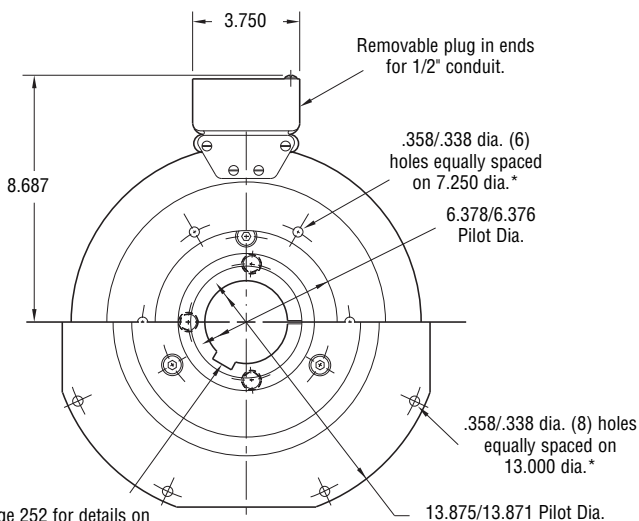

**MAGNET VIEW**

See page 252 for details on Bushings.

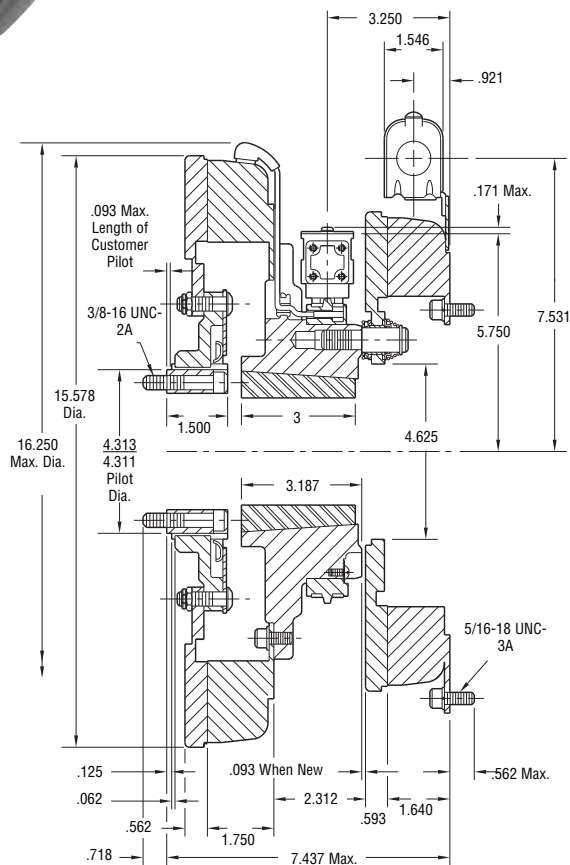

\* Mounting holes are within .010 of true position relative to pilot diameter.

### Customer Shall Maintain:

1. Concentricity of brake magnet mounting pilot diameter to mounting shaft within .010 T.I.R.
2. Squareness of brake magnet mounting face to magnet mounting shaft within .006 T.I.R.
3. Splined hub pilot diameter to be concentric with splined armature center of rotation within .010 T.I.R.

Shaft Size	.937 – 3.000
Static Torque Clutch	700 lb. ft.
Static Torque Brake	465 lb. ft.
Maximum Speed	2,000 rpm
Standard Voltage	D.C. 6, 24, 90

All dimensions are nominal unless otherwise noted.

Information on inertia and weights begins on page 239. Coil data is on pages 250 and 251.





Drawing I-25636

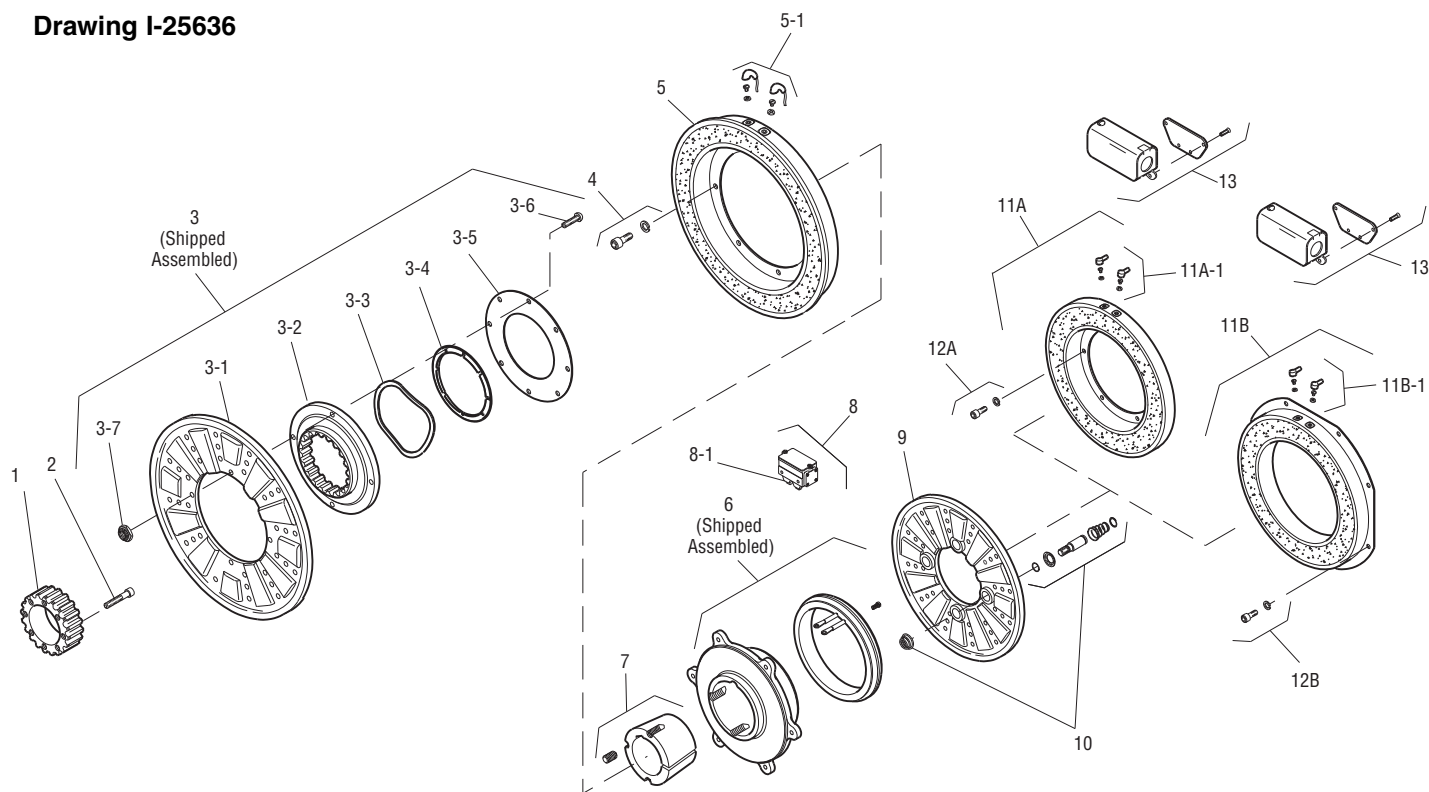

Item	Description	Part Number	Qty.
1	Splined Hub	540-0148	1
2	Mounting Accessory	5202-101-001	1
3	Armature Assembly	5324-111-001	1
3-1	Armature	5324-111-034	1
3-2	Splined Armature Adapter	104-0011	1
3-3	Autogap Spring	808-0044	1
3-4	Retainer Ring	748-0370	1
3-5	Retainer Plate	686-0003	1
3-6	Buttonhead Screw	797-0272	8
3-7	Locknut	661-0004	8
4	Mounting Accessory	5321-101-001	1
5	Magnet Assembly		
	6 Volt	5304-631-009	
	24 Volt	5304-631-011	
	90 Volt	5304-631-010	
5-1	Terminal Accessory	5311-101-001	1
6	Hub Assembly		
	Left Hand (shown)	5304-541-001	
	Right Hand	5304-541-002	
7	Bushing*	180-0262 to 180-0295	1
8	Brushholder	5300-178-001	1
8-1	Brush	176-0001	4
9	Armature Assembly	5303-111-009	1
10	Autogap Accessory	5201-101-008	4
11A	Magnet - Inside Mounted		1
	6 Volt	5313-631-005	
	24 Volt	5313-631-006	
	90 Volt	5313-631-007	

Item	Description	Part Number	Qty.
11A-1	Terminal Accessory	5311-101-001	1
11B	Magnet - Outside Mounted		1
	6 Volt	5313-631-010	
	24 Volt	5313-631-012	
	90 Volt	5313-631-011	
11B-1	Terminal Accessory	5311-101-001	1
12A	Mounting Accessory I.M.	5321-101-001	1
12B	Mounting Accessory O.M.	5321-101-002	2
13	Conduit Box	5200-101-011	1

### How to Order:

1. Specify Voltage for Item 5 and Item 11A or 11B.
2. Specify left hand or right hand hub for Item 6. Bushing enters from magnet side for L.H. hub and from hub side for R.H.
3. Specify Bore Size for Item 7.
4. Specify Inside Mounted for Items 11A and 12A or Outside Mounted for Items 11B and 12B.
5. See Controls Section.

### Example:

PCB-1525/1225 Clutch Brake per I-25636 - 90 Volt, Left Hand hub, 2" Bore, Inside Mounted

These units meet standards set forth in UL508 and are listed under guide card #NMTR2, file #59164.

These units are CSA certified under file #LR11543.

\*See page 252 for specific part numbers.

Refer to Service Manual P-214.

# Clutch/Brake Coupling

## SFPBC-500 Normal Duty

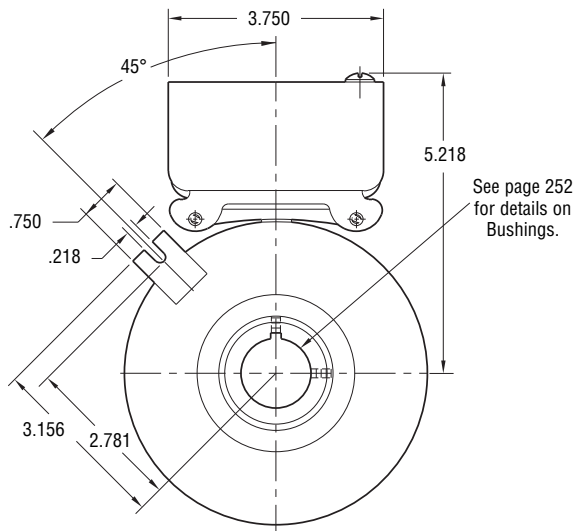

**FIELD VIEW**

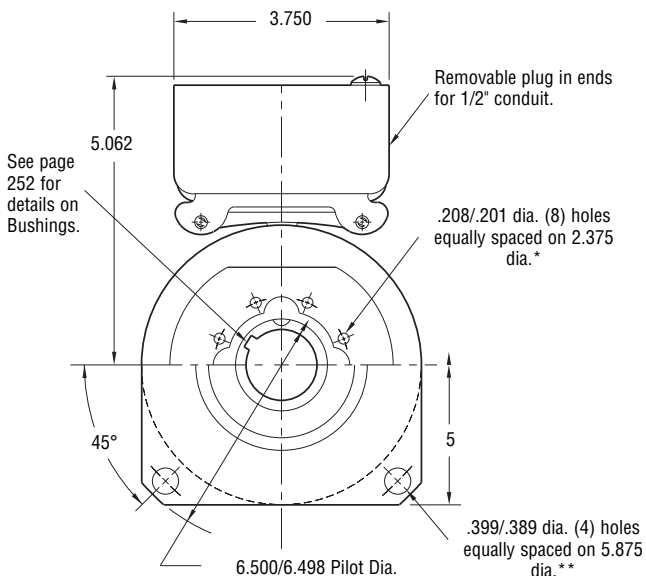

**MAGNET VIEW**

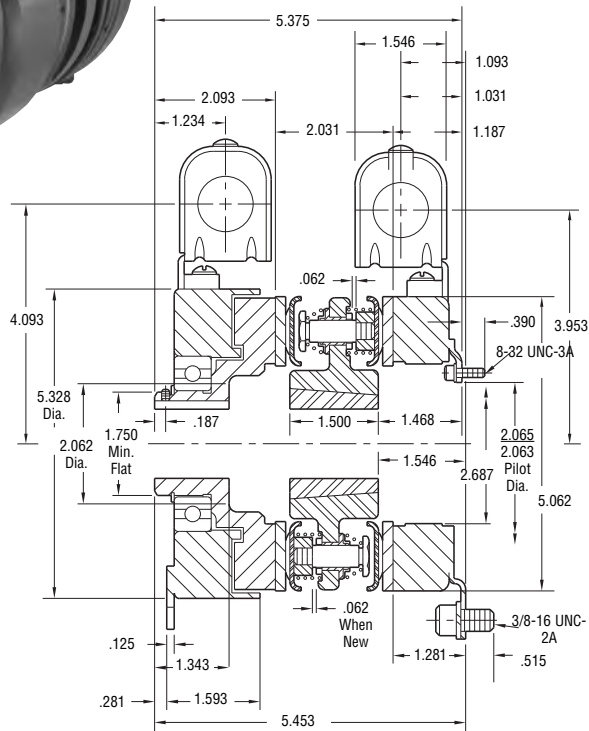

**Outside Mounted Offset Backing Plate**

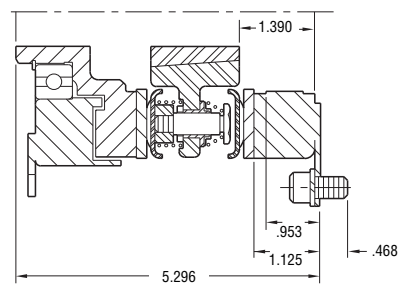

**Outside Mounted Flush Backing Plate**

\* Mounting holes are within .010 of true position relative to pilot diameter.  
 \*\* Mounting holes are within .008 of true position relative to pilot diameter.

### Customer Shall Maintain:

1. Squareness of brake mounting face with armature hub shaft within .006 T.I.R.
2. Concentricity of brake mounting pilot diameter with armature hub shaft within .010 T.I.R.
3. Concentricity of clutch magnet hub assembly shaft with armature hub shaft within .006 T.I.R.



Shaft Size	.750 – 1.250
Static Torque Clutch	50 lb. ft.
Static Torque Brake	40 lb. ft.
Maximum Speed	4,000 rpm
Standard Voltage	D.C. 6, 24, 90

All dimensions are nominal unless otherwise noted.

Information on inertia and weights begins on page 239. Coil data is on pages 250 and 251.

# Clutch/Brake Coupling

## SFPBC-500 Normal Duty

Drawing I-25546

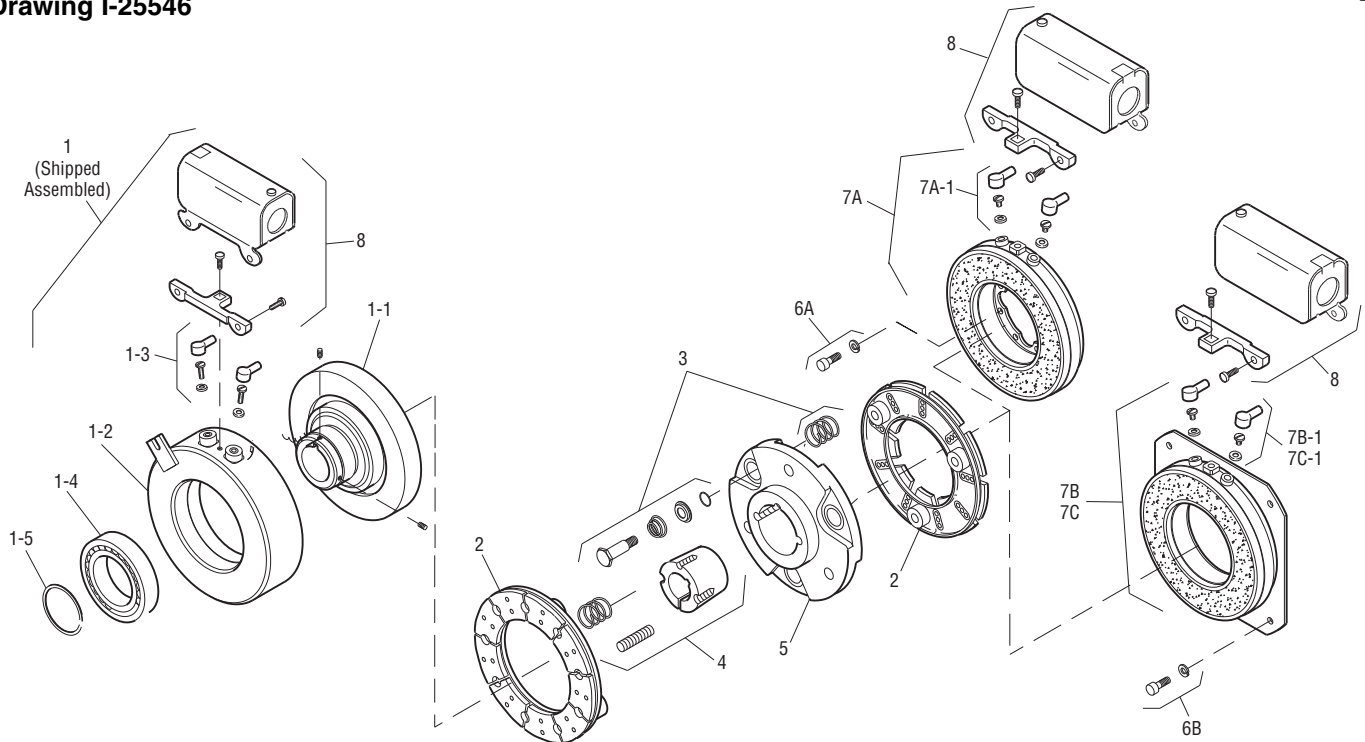

Item	Description	Part Number	Qty.
1	Field and Rotor Assembly		1
	6 Volt – 3/4" Bore	5200-452-002	
	24 Volt – 3/4" Bore	5200-452-004	
	90 Volt – 3/4" Bore	5200-452-005	
	6 Volt – 7/8" Bore	5200-452-008	
	24 Volt – 7/8" Bore	5200-452-010	
	90 Volt – 7/8" Bore	5200-452-011	
	90 Volt – 15/16" Bore	5200-452-017	
	6 Volt – 1" Bore	5200-452-020	
	24 Volt – 1" Bore	5200-452-022	
	90 Volt – 1" Bore	5200-452-023	
	6 Volt – 1-1/8" Bore	5200-452-026	
	24 Volt – 1-1/8" Bore	5200-452-028	
	90 Volt – 1-1/8" Bore	5200-452-029	
	6 Volt – 1-1/4" Bore	5200-452-032	
	90 Volt – 1-1/4" Bore	5200-452-035	
1-1	Rotor		1
	3/4" Bore	5200-751-002	
	7/8" Bore	5200-751-003	
	15/16" Bore	5200-751-004	
	1" Bore	5200-751-005	
	1-1/8" Bore	5200-751-006	
	1-1/4" Bore	5200-751-007	
1-2	Field		1
	6 Volt	5200-451-002	
	24 Volt	5200-451-004	
	90 Volt	5200-451-005	
1-3	Terminal Accessory	5311-101-001	1
1-4	Ball Bearing	166-0110	1
1-5	Retainer Ring	748-0002	1
2	Armature	5300-111-002	2
3	Autogap Accessory	5200-101-009	6
4	Bushing*- 1/2" to 1-1/4" Bore	180-0116 to 180-0128	1
5	Armature Hub	5300-541-004	1

Item	Description	Part Number	Qty.
6A	Mounting Accessory - I.M.	5102-101-001	2
6B	Mounting Accessory - O.M.	5300-101-008	1
7A	Magnet - I.M.		1
	6 Volt	5300-631-002	
	24 Volt	5300-631-003	
	90 Volt	5300-631-005	
7A-1	Terminal Accessory	5311-101-001	1
7B	Magnet - O.M. - Offset		1
	90 Volt	5300-631-014	
7B-1	Terminal Accessory	5311-101-001	1
7C	Magnet - O.M. - Flush		1
	6 Volt	5300-631-009	
	24 Volt	5300-631-010	
	90 Volt	5300-631-011	
7C-1	Terminal Accessory	5311-101-001	1
8	Conduit Box	5200-101-010	2

### How to Order:

1. Specify Bore Size for Item 1 and Item 4.
2. Specify Voltage for Item 1 and Item 7A, 7B or 7C.
3. Specify Inside Mounted for Item 7A and Outside Mounted (Offset) for Item 7B or Outside Mounted (Flush) for Item 7C.
4. See Controls Section.

### Example:

SFPBC-500 Clutch Brake Coupling per I-25546 - 90 Volt, Inside Mounted, 1" Bore

These units, when used in conjunction with the correct Warner Electric conduit box, meet the standards of UL508 and are listed under guide card #NMTR, file #59164.

These units are CSA certified under file #LR11543.

\*See page 252 for specific part numbers.

Refer to Service Manual P-202.

# Clutch/Brake Coupling

## SFPBC-500 Heavy Duty

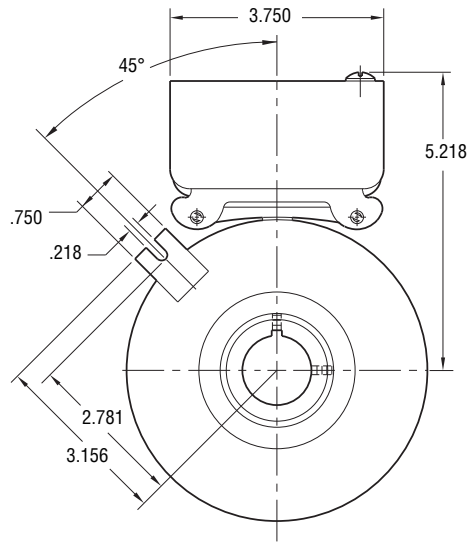

**FIELD VIEW**

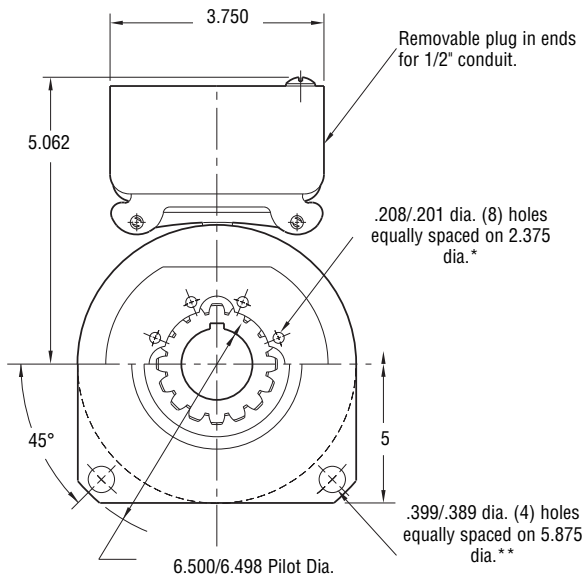

**MAGNET VIEW**

\* Mounting holes are within .010 of true position relative to pilot diameter.

\*\* Mounting holes are within .008 of true position relative to pilot diameter.

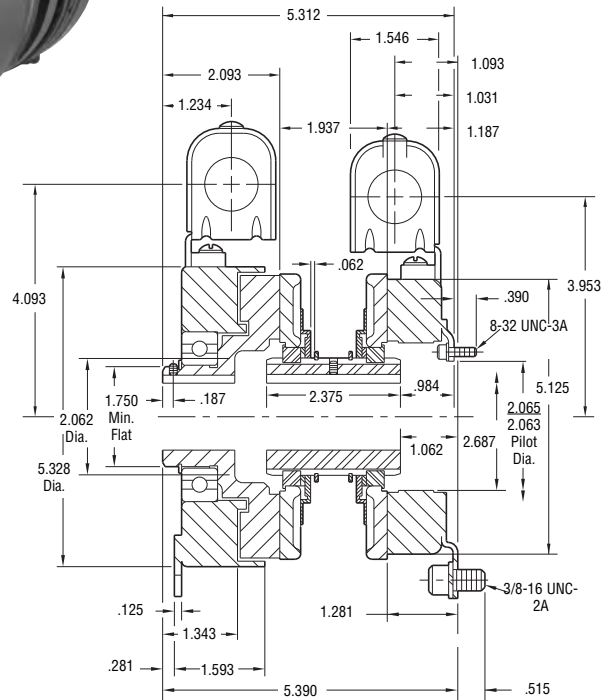

**Outside Mounted Offset Backing Plate**

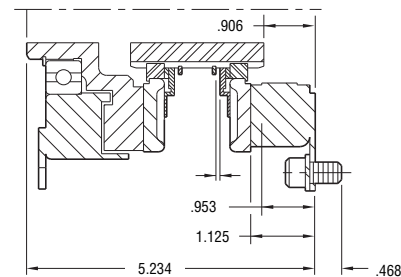

**Outside Mounted Flush Backing Plate**

### Customer Shall Maintain:

1. Squareness of brake mounting face with armature hub shaft within .006 T.I.R.
2. Concentricity of brake mounting pilot diameter with armature hub shaft within .010 T.I.R.
2. Concentricity of clutch magnet hub assembly shaft with armature hub shaft within .006 T.I.R.



Shaft Size	.750 – 1.250
Static Torque Clutch	50 lb. ft.
Static Torque Brake	40 lb. ft.
Maximum Speed	4,000 rpm
Standard Voltage	D.C. 6, 24, 90

All dimensions are nominal unless otherwise noted.

Information on inertia and weights begins on page 239. Coil data is on pages 250 and 251.

# Clutch/Brake Coupling

## SFPBC-500 Heavy Duty

Drawing I-25554

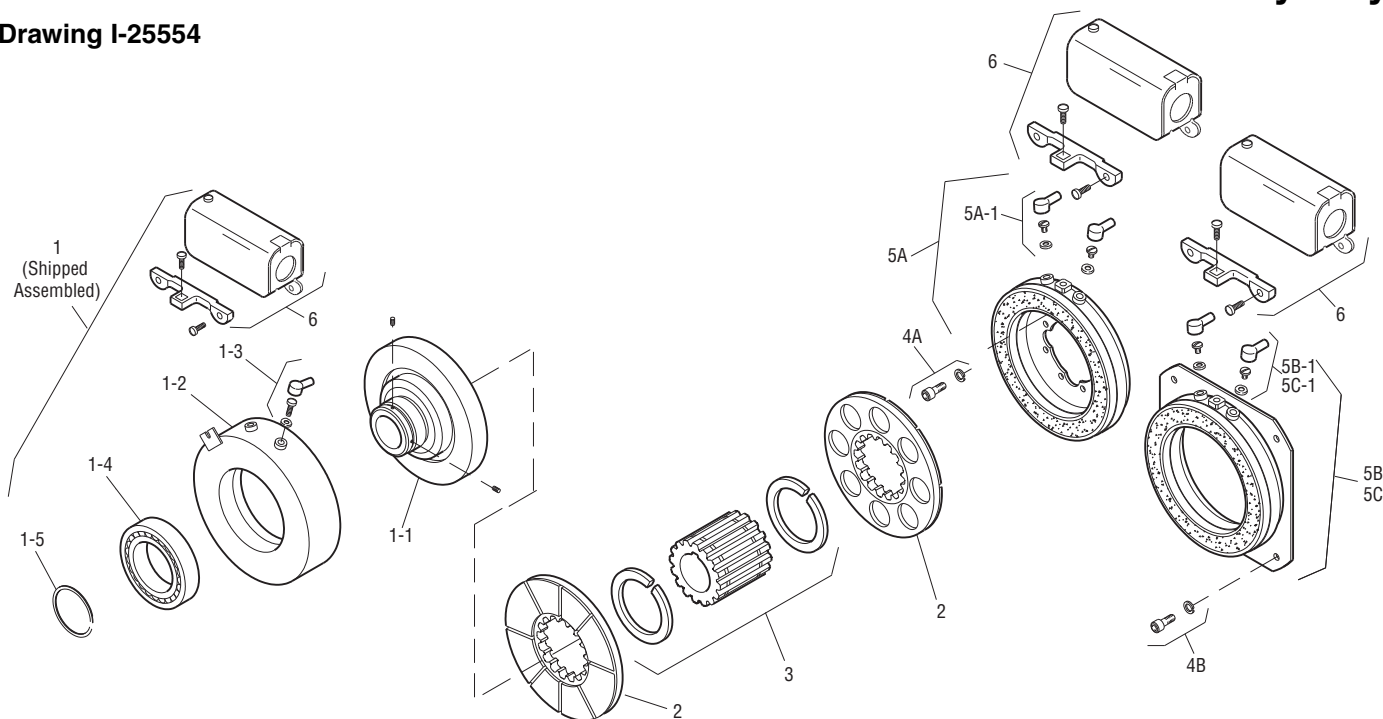

Item	Description	Part Number	Qty.
1	Field and Rotor Assembly		1
	6 Volt – 3/4" Bore	5200-452-002	
	24 Volt – 3/4" Bore	5200-452-004	
	90 Volt – 3/4" Bore	5200-452-005	
	6 Volt – 7/8" Bore	5200-452-008	
	24 Volt – 7/8" Bore	5200-452-010	
	90 Volt – 7/8" Bore	5200-452-011	
	90 Volt – 15/16" Bore	5200-452-017	
	6 Volt – 1" Bore	5200-452-020	
	24 Volt – 1" Bore	5200-452-022	
	90 Volt – 1" Bore	5200-452-023	
	6 Volt – 1-1/8" Bore	5200-452-026	
	24 Volt – 1-1/8" Bore	5200-452-028	
	90 Volt – 1-1/8" Bore	5200-452-029	
	6 Volt – 1-1/4" Bore	5200-452-032	
	90 Volt – 1-1/4" Bore	5200-452-035	
1-1	Rotor		1
	3/4" Bore	5200-751-002	
	7/8" Bore	5200-751-003	
	15/16" Bore	5200-751-004	
	1" Bore	5200-751-005	
	1-1/8" Bore	5200-751-006	
	1-1/4" Bore	5200-751-007	
1-2	Field		1
	6 Volt	5200-451-002	
	24 Volt	5200-451-004	
	90 Volt	5200-451-005	
1-3	Terminal Accessory	5311-101-001	1
1-4	Ball Bearing	166-0110	1
1-5	Retainer Ring	748-0002	1
2	Armature	5230-111-002	2
3	Armature Hub		1
	3/4" Bore	5300-541-006	
	7/8" Bore	5300-541-007	
	15/16" Bore	5300-541-008	
	1" Bore	5300-541-009	
	1-1/8" Bore	5300-541-010	
	1-1/4" Bore	5300-541-011	

Item	Description	Part Number	Qty.
4A	Mounting Accessory - I.M.	5102-101-001	2
4B	Mounting Accessory - O.M.	5300-101-008	1
5A	Magnet - I.M.		1
	6 Volt	5300-631-002	
	24 Volt	5300-631-003	
	90 Volt	5300-631-005	
5A-1	Terminal Accessory	5311-101-001	1
5B	Magnet - O.M. - Offset		1
	90 Volt	5300-631-014	
5B-1	Terminal Accessory	5311-101-001	1
5C	Magnet - O.M. - Flush		1
	6 Volt	5300-631-009	
	24 Volt	5300-631-010	
	90 Volt	5300-631-011	
5C-1	Terminal Accessory	5311-101-001	1
6	Conduit Box	5200-101-010	2

### How to Order:

1. Specify Bore Size for Item 1 and Item 3.
2. Specify Voltage for Item 1 and Item 5A, 5B or 5C.
3. Specify Inside Mounted for Item 5A and Outside Mounted (Offset) for Item 5B or Outside Mounted (Flush) for Item 5C.
4. See Controls Section.

### Example:

SFPBC-500 Clutch Brake Coupling per I-25554 - 90 Volt, Inside Mounted, 1" Bore

These units, when used in conjunction with the correct Warner Electric conduit box, meet the standards of UL508 and are listed under guide card #NMTR, file #59164.

These units are CSA certified under file #LR11543.

Refer to Service Manual P-202.

# Clutch/Brake Coupling

## SFPBC-650

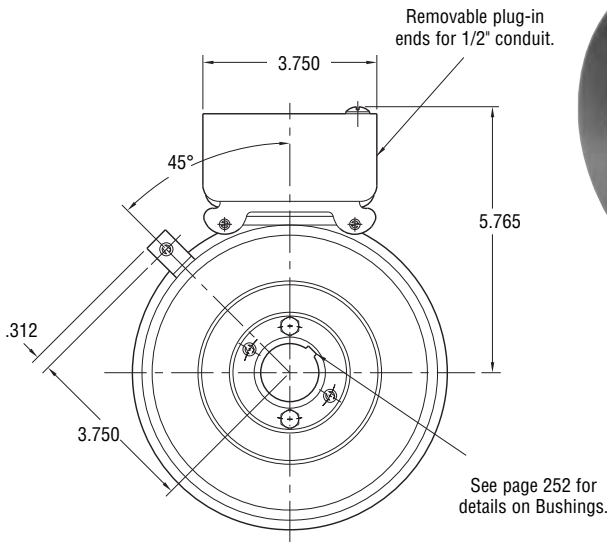

**FIELD VIEW**

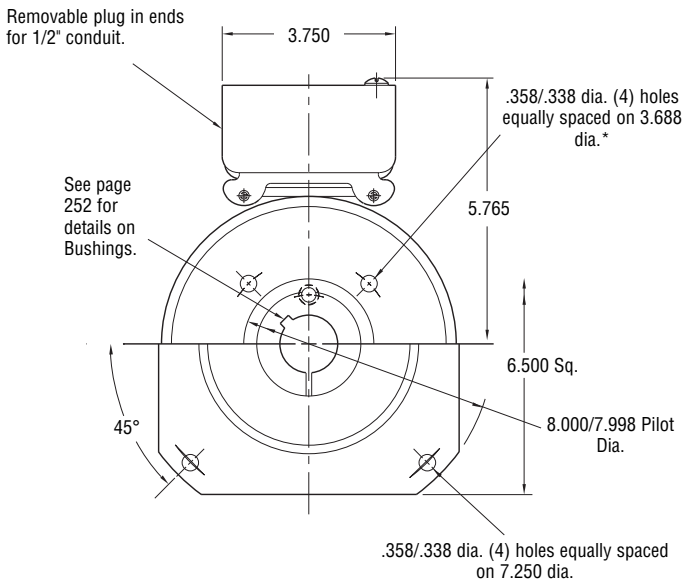

**MAGNET VIEW  
(Inside & Outside Mounted)**

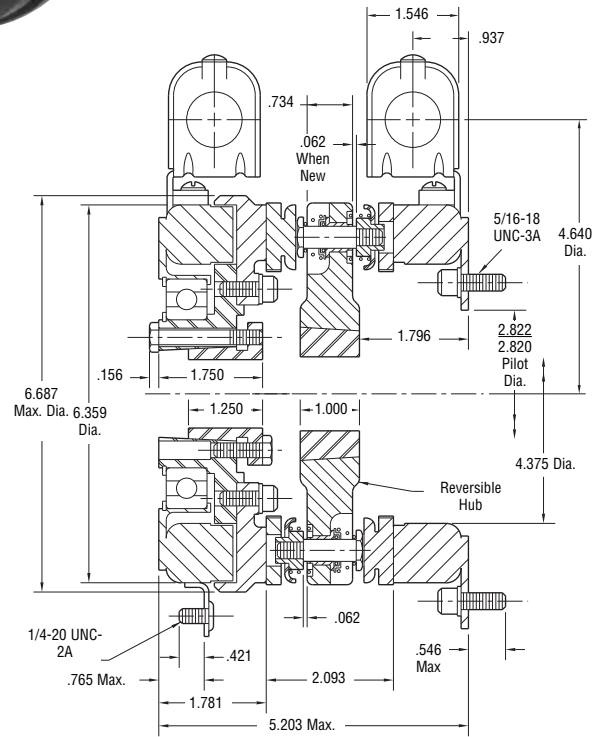

\* Mounting holes are within .010 of true position relative to pilot diameter.

### Customer Shall Maintain:

1. Squareness of brake mounting face with armature hub shaft within .006 T.I.R.
2. Concentricity of brake mounting pilot diameter with armature hub shaft within .010 T.I.R.
3. Concentricity of clutch magnet hub assembly shaft with armature hub shaft within .006 T.I.R.

Shaft Size	.500 – 1.500
Static Torque Clutch	95 lb. ft.
Static Torque Brake	95 lb. ft.
Maximum Speed	3,600 rpm
Standard Voltage	D.C. 6, 24, 90

All dimensions are nominal unless otherwise noted.

Information on inertia and weights begins on page 239. Coil data is on pages 250 and 251.



Drawing I-25751

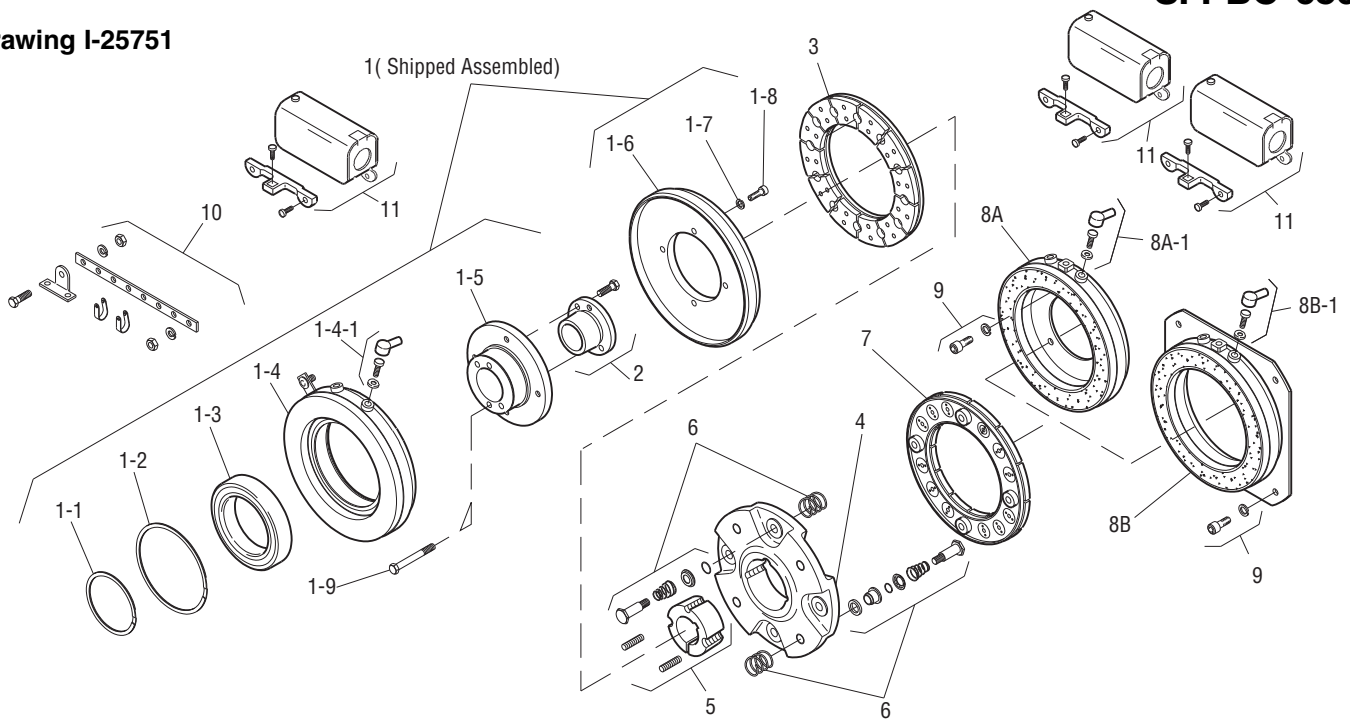

Item	Description	Part Number	Qty.
1	Field & Rotor Assembly		1
	6 Volt	5207-452-002	
	24 Volt	5207-452-005	
	90 Volt	5207-452-004	
1-1	Retainer Ring External	748-0004	1
1-2	Retainer Ring Internal	748-0104	1
1-3	Ball Bearing	166-0104	1
1-4	Field Assembly		1
	6 Volt	5281-451-002	
	24 Volt	5281-451-004	
	90 Volt	5281-451-005	
1-4-1	Terminal Accessory	5311-101-001	3
1-5	Rotor Hub	540-0614	1
1-6	Rotor Assembly	5281-751-001	1
1-7	Lockwasher	950-0355	4
1-8	Capscrew	797-0083	4
1-9	Reverse Mounting Accessory	5201-101-005	1
2	Bushing*		1
	1/2" to 1-1/2" Bore	180-0002 to 180-0018	
3	Armature Clutch	5281-111-002	1
4	Armature Hub	5207-541-002	1
5	Bushing*		
	1/2" to 1-5/8" Bore	180-0326 to 180-0344	1
6	Autogap Accessory	5181-101-010	8
7	Armature - Brake	5281-111-002	1
8A	Magnet - Inside Mounted		1
	6 Volt	5369-631-003	
	24 Volt	5369-631-006	
	90 Volt	5369-631-005	

Item	Description	Part Number	Qty.
8A-1	Terminal Accessory	5311-101-001	2
8B	Magnet - Outside Mounted		1
	6 Volt	5369-631-009	
	24 Volt	5369-631-012	
	90 Volt	5369-631-011	
8B-1	Terminal Accessory	5311-101-001	2
9	Mounting Accessory	5321-101-002	1
†10	Torque Arm Accessory	5207-101-003	1
11	Conduit Box	5200-101-010	3

### How to Order:

1. Specify Voltage for Item 1 and Item 8.
2. Specify Bore Size for Item 2 and Item 5.
3. Specify Inside Mounted for Item 8A and Outside Mounted for Item 8B.
4. See Controls Section.

### Example:

SFPBC-650 per I-25751 - 90 Volt, 1" Bore

These units, when used in conjunction with the correct Warner Electric conduit box, meet the standards of UL508 and are listed under guide card #NMTR, file #59164. These units are CSA certified under file #LR11543

\*See page 252 for specific part numbers.

Refer to Service Manual P-202.

†Optional – not included in price.

# Clutch/Brake Coupling

## PCBC-500 Normal Duty

1/2-14 NPSM Am. std. straight pipe tap.

See page 252 for details on Bushings.

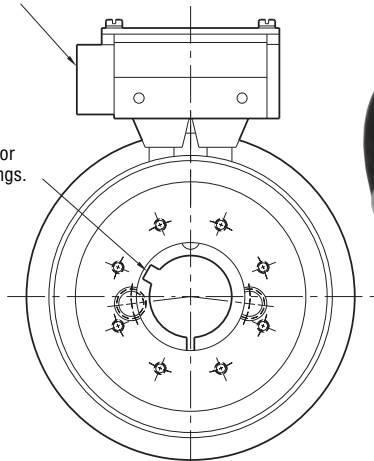

**COLLECTOR RING VIEW**

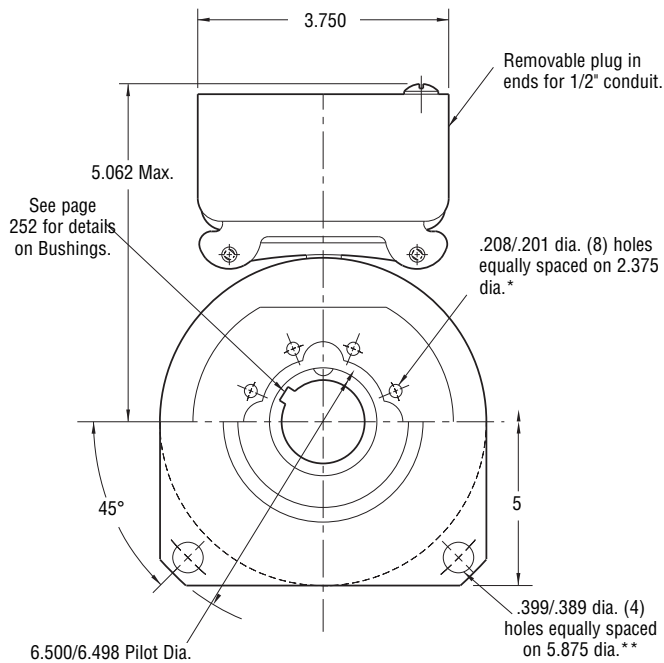

**MAGNET VIEW  
(Inside & Outside Mounted)**

\* Mounting holes are within .010 of true position relative to pilot diameter.

\*\* Mounting holes are within .008 of true position relative to pilot diameter.

### Customer Shall Maintain:

1. Squareness of brake mounting face with armature hub shaft within .006 T.I.R.
2. Concentricity of brake mounting pilot diameter with armature hub shaft within .010 T.I.R.
3. Concentricity of clutch magnet hub assembly shaft with armature hub shaft within .006 T.I.R.

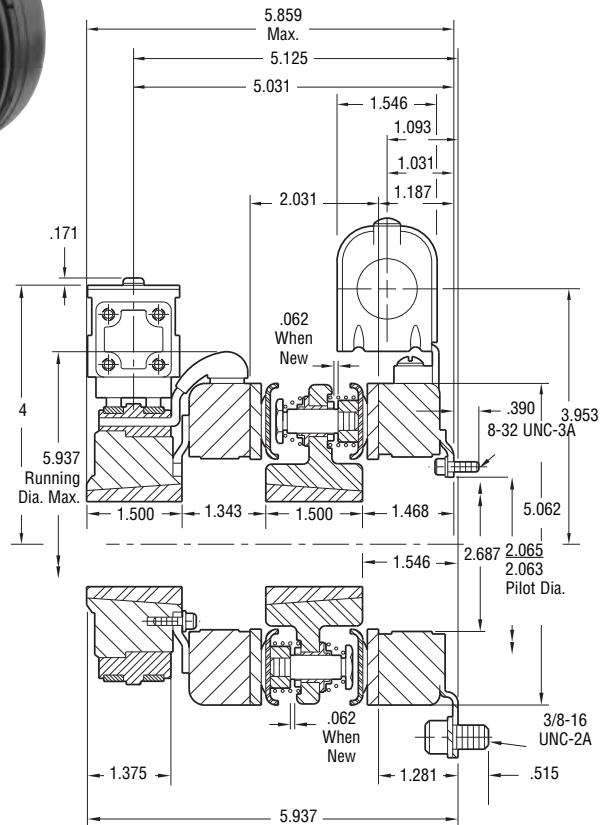
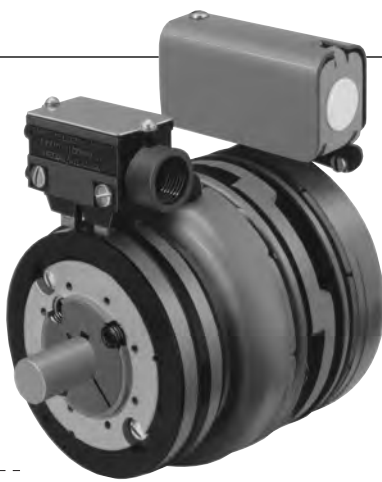

**Outside Mounted Offset Backing Plate**

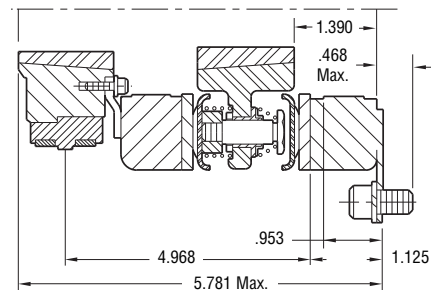

**Outside Mounted Flush Backing Plate**

Armature Shaft	.500 – 1.250
Magnet Shaft	.500 – 1.250
Static Torque	40 lb. ft.
Maximum Speed	5,400 rpm
Standard Voltage	D.C. 6, 24, 90

All dimensions are nominal unless otherwise noted.

Information on inertia and weights begins on page 239. Coil data is on pages 250 and 251.



Drawing I-25547

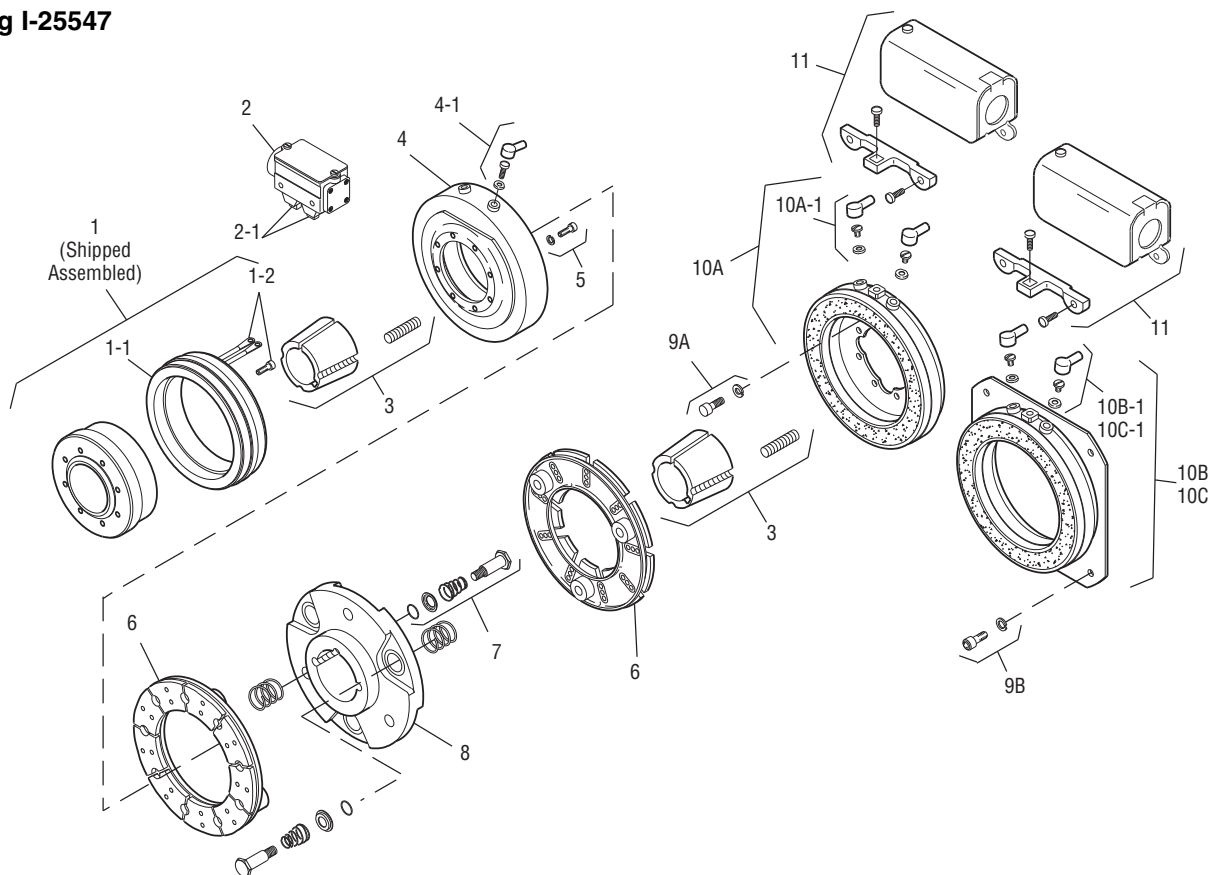

Item	Description	Part Number	Qty.
1	Magnet Hub	5300-541-001	1
1-1	Collector Ring	5300-749-001	1
1-2	Collector Ring Mounting Accessory	5300-101-002	1
2	Brushholder	5300-178-001	1
2-1	Brush	176-0001	4
3	Bushing*		2
	1/2" - 1/4" Bore	180-0116 to 180-0128	
4	Magnet, Clutch		1
	6 Volt	5300-631-002	
	24 Volt	5300-631-003	
	90 Volt	5300-631-005	
4-1	Terminal Accessory	5311-101-001	1
5	Mounting Accessory	5102-101-001	2
6	Armature	5300-111-002	2
7	Autogap Accessory	5200-101-009	6
8	Armature Hub	5300-541-004	1
9A	Mounting Accessory - I.M.	5102-101-001	2
9B	Mounting Accessory - O.M.	5300-101-008	1
10A	Magnet - I.M.		1
	6 Volt	5300-631-002	
	24 Volt	5300-631-003	
	90 Volt	5300-631-005	
10A-1	Terminal Accessory	5311-101-001	1

Item	Description	Part Number	Qty.
10B	Magnet - O.M. - Offset		1
	90 Volt	5300-631-014	
10B-1	Terminal Accessory	5311-101-001	1
10C	Magnet - O.M. - Flush		1
	6 Volt	5300-631-009	
	24 Volt	5300-631-010	
	90 Volt	5300-631-011	
10C-1	Terminal Accessory	5311-101-001	1
11	Conduit Box	5200-101-010	1

### How to Order:

1. Specify Bore Size for Item 3 (two shafts).
2. Specify Voltage for Item 4 and Item 10A, 10B or 10C.
3. Specify Inside Mounted for Item 10A and Outside Mounted (Offset) for Item 10B or Outside Mounted (Flush) for Item 10C.
4. See Controls Section.

### Example:

PCBC-500 Clutch Brake Coupling per I-25547 - 90 Volt, Inside Mounted, 1" Bore

These units meet the standards of UL508 and are listed under guide card #NMTR2, file #59164. These units are CSA certified under file #LR11543.

\*See page 252 for specific part numbers.

Refer to Service Manual P-203.

# Clutch/Brake Coupling

## PCBC-500 Heavy Duty



1/2-14 NPSM Am. std. straight pipe tap.

See page 252 for details on Bushings.

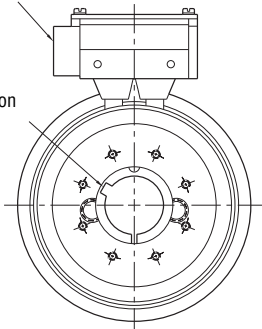

**COLLECTOR RING VIEW**

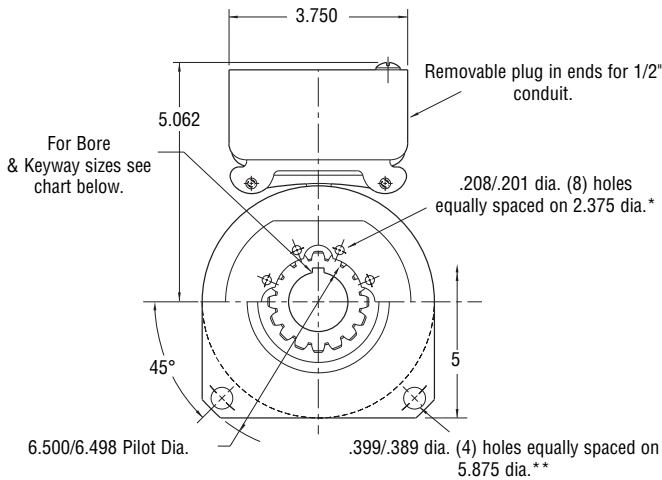

**MAGNET VIEW**

\* Mounting holes are within .010 of true position relative to pilot diameter.

\*\* Mounting holes are within .008 of true position relative to pilot diameter.

### Bore and Keyway Dimensions

Armature Bore Dia.	Keyway
.751/.750 .876/.875	.187 x .093
.9385/.9375 1.001/1.000 1.126/1.125 1.251/1.250	.250 x .125

### Customer Shall Maintain:

1. Squareness of brake mounting face with armature hub shaft within .006 T.I.R.
2. Concentricity of brake mounting pilot diameter with armature hub shaft within .010 T.I.R.
3. Concentricity of clutch magnet hub assembly shaft with armature hub shaft within .006 T.I.R.

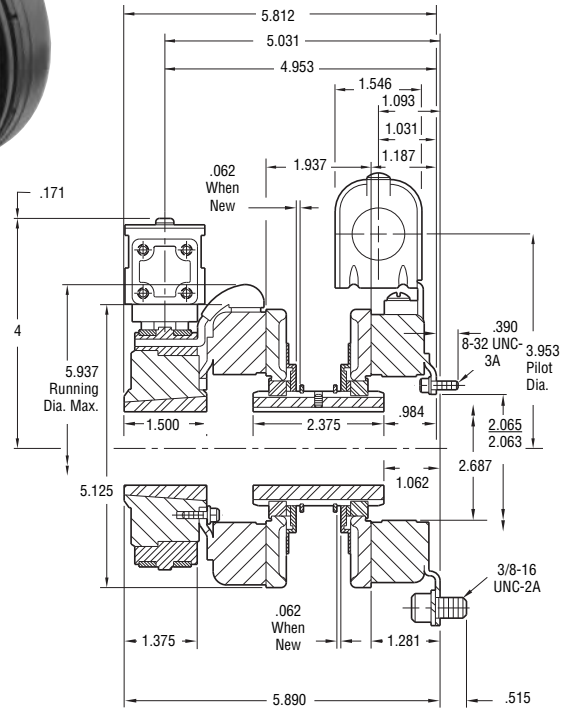

**Outside Mounted Offset Backing Plate**

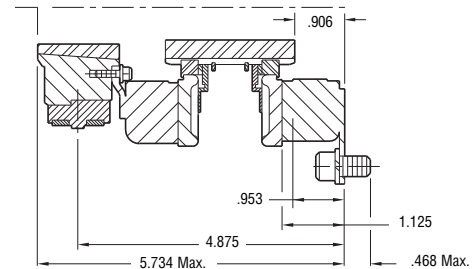

**Outside Mounted Flush Backing Plate**

Armature Shaft	.500 – 1.250
Magnet Shaft	.750 – 1.250
Static Torque	40 lb. ft.
Maximum Speed	5,400 rpm
Standard Voltage	D.C. 6, 24, 90

All dimensions are nominal unless otherwise noted.

Information on inertia and weights begins on page 239. Coil data is on pages 250 and 251.

# Clutch/Brake Coupling

## PCBC-500 Heavy Duty

Drawing I-25553

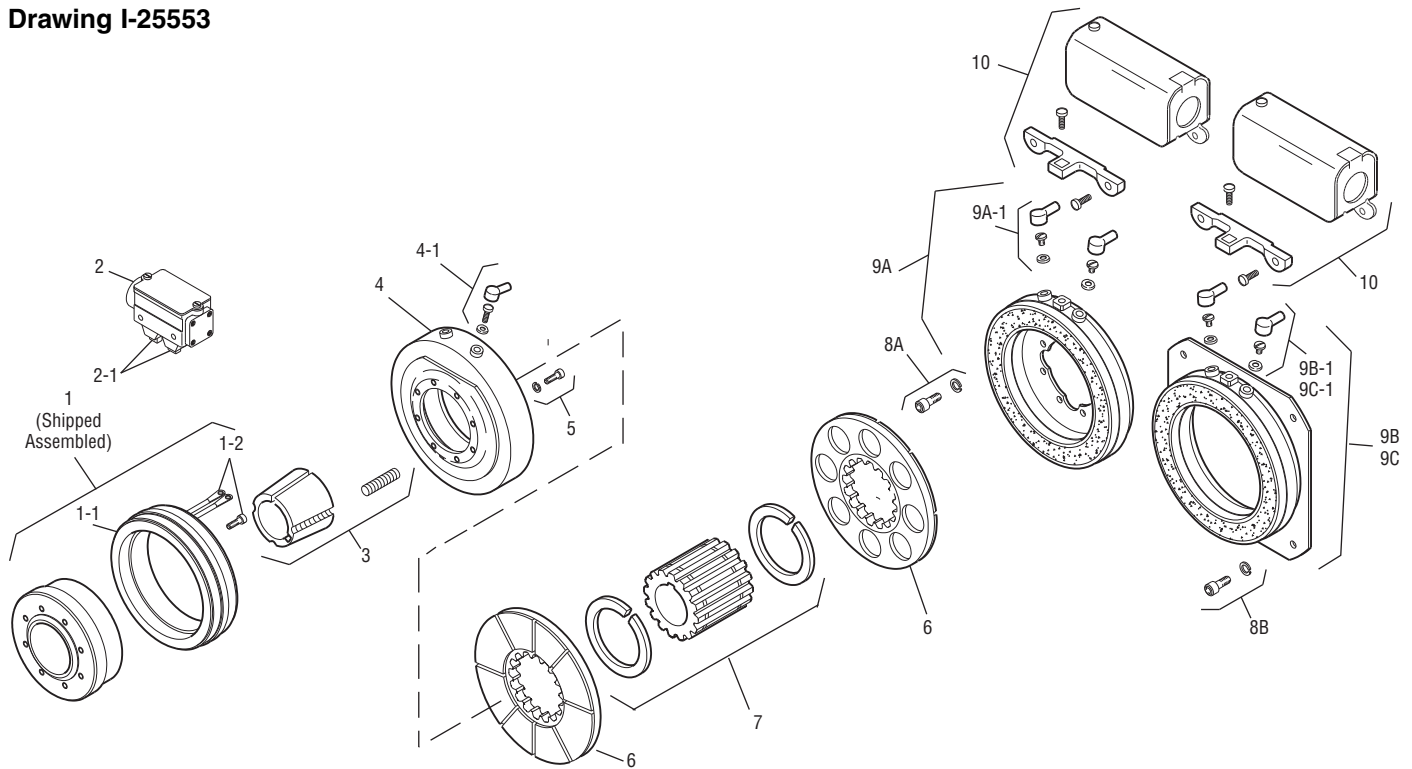

Item	Description	Part Number	Qty.
1	Magnet Hub	5300-541-001	1
1-1	Collector Ring	5300-749-001	1
1-2	Collector Ring Mounting Accessory	5300-101-002	1
2	Brushholder	5300-178-001	1
2-1	Brush	176-0001	4
3	Bushing*		1
	1/2" - 1-1/4" Bore	180-0116 to 180-0128	
4	Magnet, Clutch		1
	6 Volt	5300-631-002	
	24 Volt	5300-631-003	
	90 Volt	5300-631-005	
4-1	Terminal Accessory	5311-101-001	1
5	Mounting Accessory	5102-101-001	2
6	Armature	5230-111-002	2
7	Armature Hub		1
	<b>Bore</b>	<b>Keyway</b>	
	3/4"	3/16 x 3/32	5300-541-006
	7/8"	3/16 x 3/32	5300-541-007
	15/16"	1/4 x 1/8	5300-541-008
	1"	1/4 x 1/8	5300-541-009
	1-1/8"	1/4 x 1/8	5300-541-010
	1-1/4"	1/4 x 1/8	5300-541-011
8A	Mounting Accessory - I.M.	5102-101-001	2
8B	Mounting Accessory - O.M.	5300-101-008	1
9A	Magnet - I.M.		1
	6 Volt	5300-631-002	
	24 Volt	5300-631-003	
	90 Volt	5300-631-005	

Item	Description	Part Number	Qty.
9A-1	Terminal Accessory	5311-101-001	1
9B	Magnet - O.M. - Offset		1
	90 Volt	5300-631-014	
9B-1	Terminal Accessory	5311-101-001	1
9C	Magnet - O.M. - Flush		1
	6 Volt	5300-631-009	
	24 Volt	5300-631-010	
	90 Volt	5300-631-011	
9C-1	Terminal Accessory	5311-101-001	1
10	Conduit Box	5200-101-010	1

### How to Order:

1. Specify Bore Size for Items 3 and 7.
2. Specify Voltage for Item 4 and Item 9A, 9B or 9C.
3. Specify Inside Mounted for Item 9A and Outside Mounted (Offset) for Item 9B or Outside Mounted (Flush) for Item 9C.
4. Specify Inside Mount for Item 8A or Outside Mount for Item 8B.
5. See Controls Section.

### Example:

PCBC-500 Clutch Brake Coupling per I-25553 - 90 Volt, Outside Mounted Flush, 1" Bore

These units meet the standards of UL508 and are listed under guide card #NMTR2, file #59164. These units are CSA certified under file #LR11543.

\*See page 252 for specific part numbers.

Refer to Service Manual P-203.

# Clutch/Brake Coupling

## PCBC-825

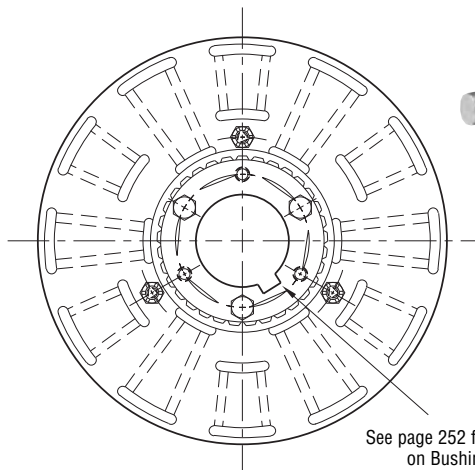

**ARMATURE VIEW**

See page 252 for details on Bushings.

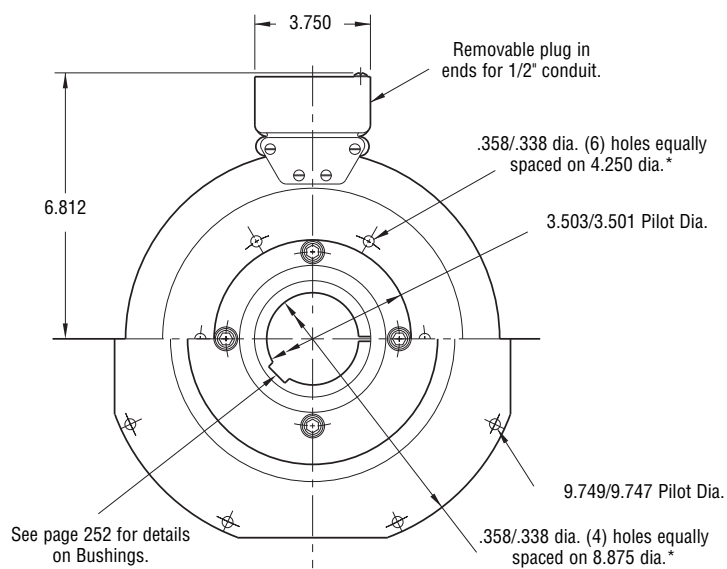
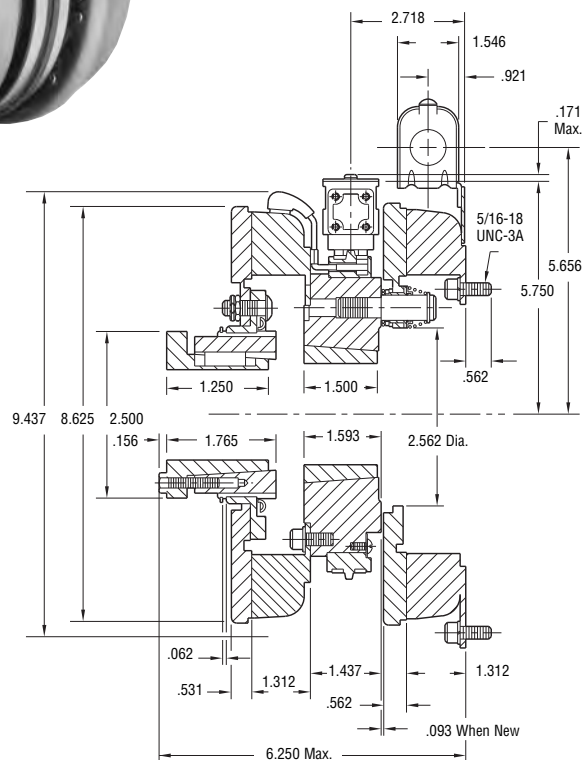

**MAGNET VIEW  
(Inside & Outside Mounted)**

### Customer Shall Maintain:

1. Armature mounting shaft concentric with magnet mounting shaft within .006 T.I.R.
2. Squareness of brake magnet mounting face with magnet mounting shaft within .006 T.I.R.
3. Concentricity of brake magnet mounting pilot diameter with magnet mounting shaft within .010 T.I.R.
4. Angular alignment of shafts within 1/2 degree.

\* Mounting holes are within .010 of true position relative to pilot diameter.

Armature Shaft	.500 – 1.500
Magnet Shaft	.500 – 1.625
Static Torque	125 lb.ft.
Maximum Speed	4,000 rpm
Standard Voltage	D.C. 6, 24, 90

All dimensions are nominal unless otherwise noted.

Information on inertia and weights begins on page 239. Coil data is on pages 250 and 251.



Drawing I-25570

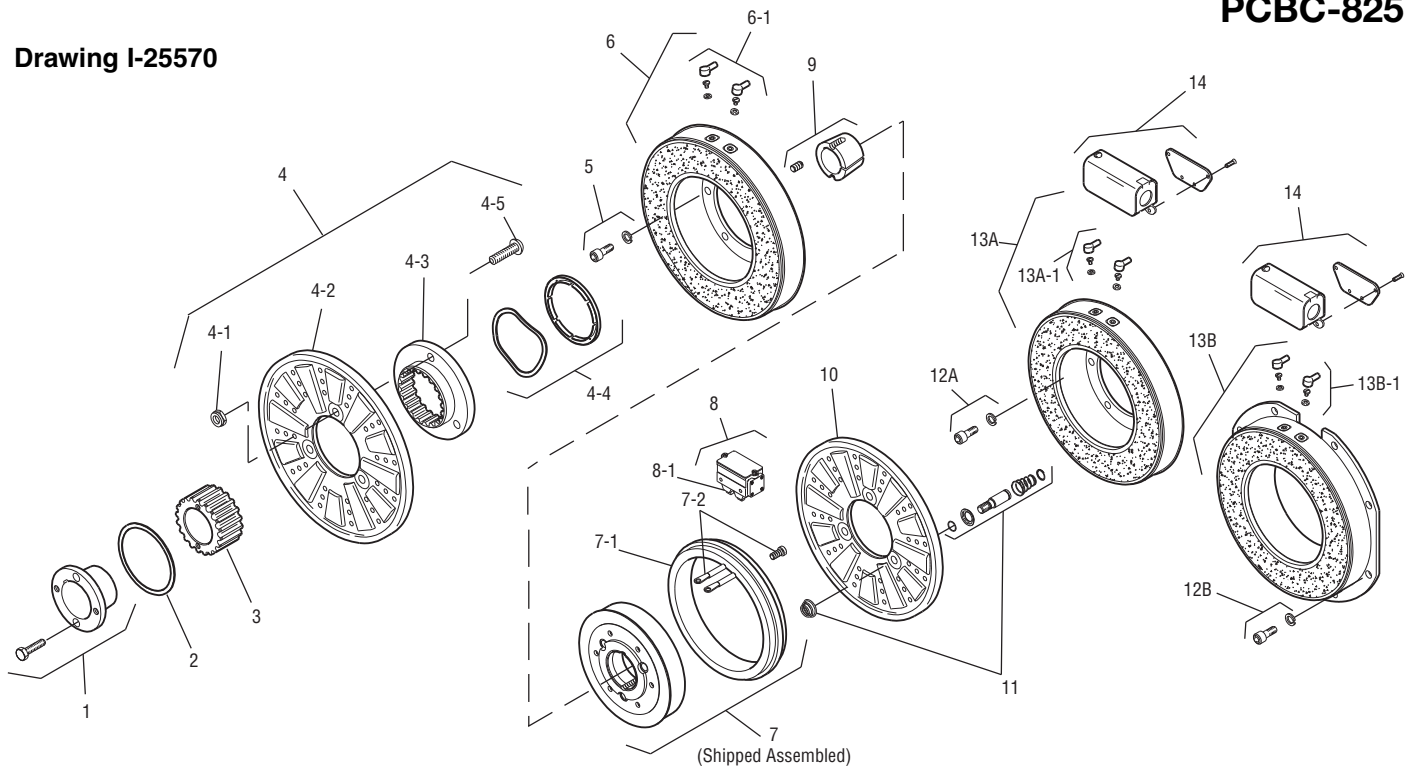

Item	Description	Part Number	Qty.
1	Bushing* - 1/2" to 1-1/2" Bore	180-0002 to 180-0018	1
2	Retainer Ring	748-0006	1
3	Splined Hub	540-0057	1
4	Armature & Splined Adapter	5321-111-001	1
4-1	Locknut	661-0004	3
4-2	Armature	5321-111-022	1
4-3	Splined Adapter	104-0008	1
4-4	Autogap Accessory	5321-101-006	1
4-5	Screw	797-0272	3
5	Mounting Accessory	5321-101-001	1
6	Magnet		1
	6 Volt	5301-631-002	
	24 Volt	5301-631-004	
	90 Volt	5301-631-005	
6-1	Terminal Accessory	5311-101-001	1
7	Magnet Hub		1
	Left Hand (shown)	5301-541-001	
	Right Hand	5301-541-002	
7-1	Collector Ring	5301-749-001	1
7-2	Collector Ring Accessory	5301-101-002	1
8	Brushholder	5300-178-001	1
8-1	Brush	176-0001	4
9	Bushing* - 1/2" to 1-5/8" Bore	180-0131 to 180-0149	1
10	Armature	5301-111-018	1
11	Autogap Accessory	5201-101-008	3
12A	Mounting Accessory - I.M.	5321-101-001	1
12B	Mounting Accessory - O.M.	5321-101-002	1

Item	Description	Part Number	Qty.
13A	Magnet - Inside Mounted		1
	6 Volt	5311-631-002	
	24 Volt	5311-631-003	
	90 Volt	5311-631-004	
13A-1	Terminal Accessory	5311-101-001	1
13B	Magnet - Outside Mounted		1
	6 Volt	5311-631-007	
	24 Volt	5311-631-009	
	90 Volt	5311-631-008	
13B-1	Terminal Accessory	5311-101-001	1
14	Conduit Box	5200-101-011	1

### How to Order:

1. Specify Bore Size for Items 1 and 9.
2. Specify Voltage for Items 6 and 13.
3. Specify left hand or right hand hub for Item 7. Bushing enters from magnet side for L.H. hub and from hub side for R.H.
4. Specify Inside Mounted for Items 12A and 13A or Outside Mounted for Items 12B and 13B.
5. See Controls Section.

### Example:

PCBC-825 Clutch Brake Coupling per I-25570 - 90 Volt, Inside Mounted, Left Hand hub, 1" Bore, ( Items 1 and 9)

These units meet the standards of UL508 and are listed under guide card #NMTR2, file #59164. These units are CSA certified under file #LR11543.

\*See page 252 for specific part numbers.

Refer to Service Manual P-205.

# Clutch/Brake Coupling

## PCBC-1000

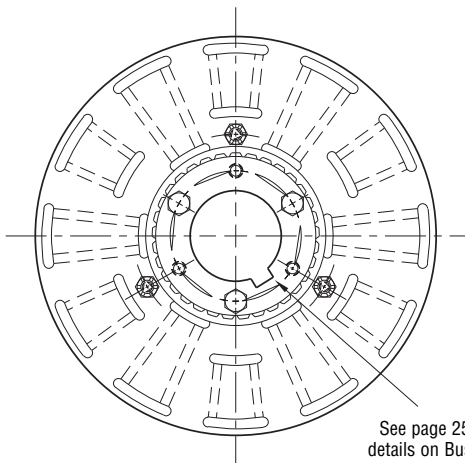

**ARMATURE VIEW**

See page 252 for details on Bushings.

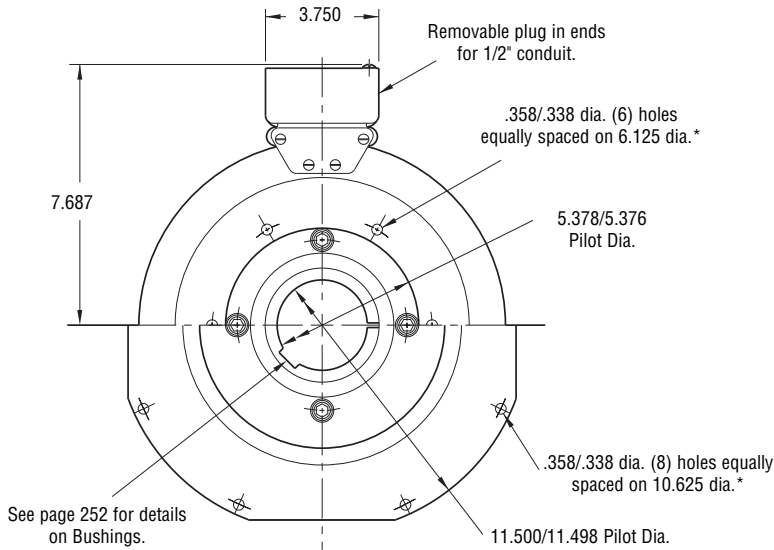

**MAGNET VIEW  
(Inside & Outside Mounted)**

### Customer Shall Maintain:

1. Armature mounting shaft concentric with magnet mounting shaft within .006 T.I.R.
2. Squareness of brake magnet mounting face with magnet mounting shaft within .006 T.I.R.
3. Concentricity of brake magnet mounting pilot diameter with magnet mounting shaft within .010 T.I.R.
4. Angular alignment of shafts within 1/2 degree.

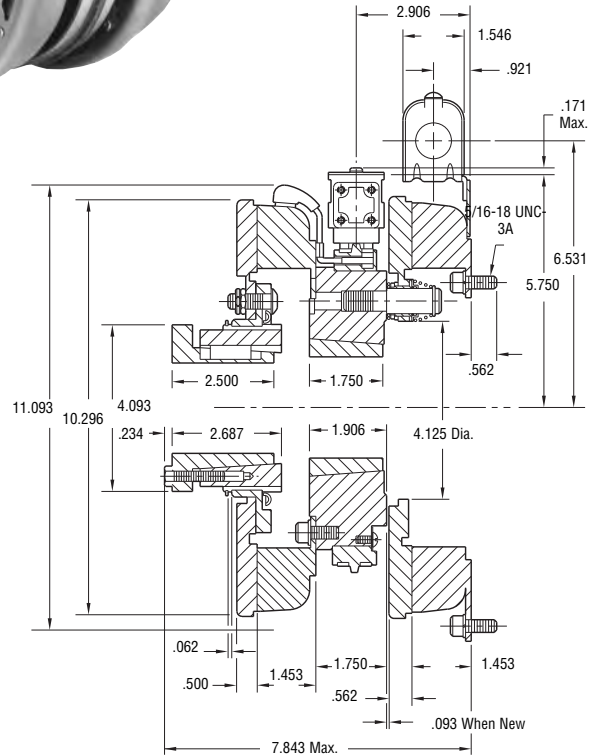

\* Mounting holes are within .010 of true position relative to pilot diameter.

Armature Shaft	.750 – 2.687
Magnetic Shaft	.500 – 2.500
Static Torque	240 lb.ft.
Maximum Speed	3,600 rpm
Standard Voltage	D.C. 6, 24, 90

All dimensions are nominal unless otherwise noted.

Information on inertia and weights begins on page 239. Coil data is on pages 250 and 251.



**Drawing I-25590**

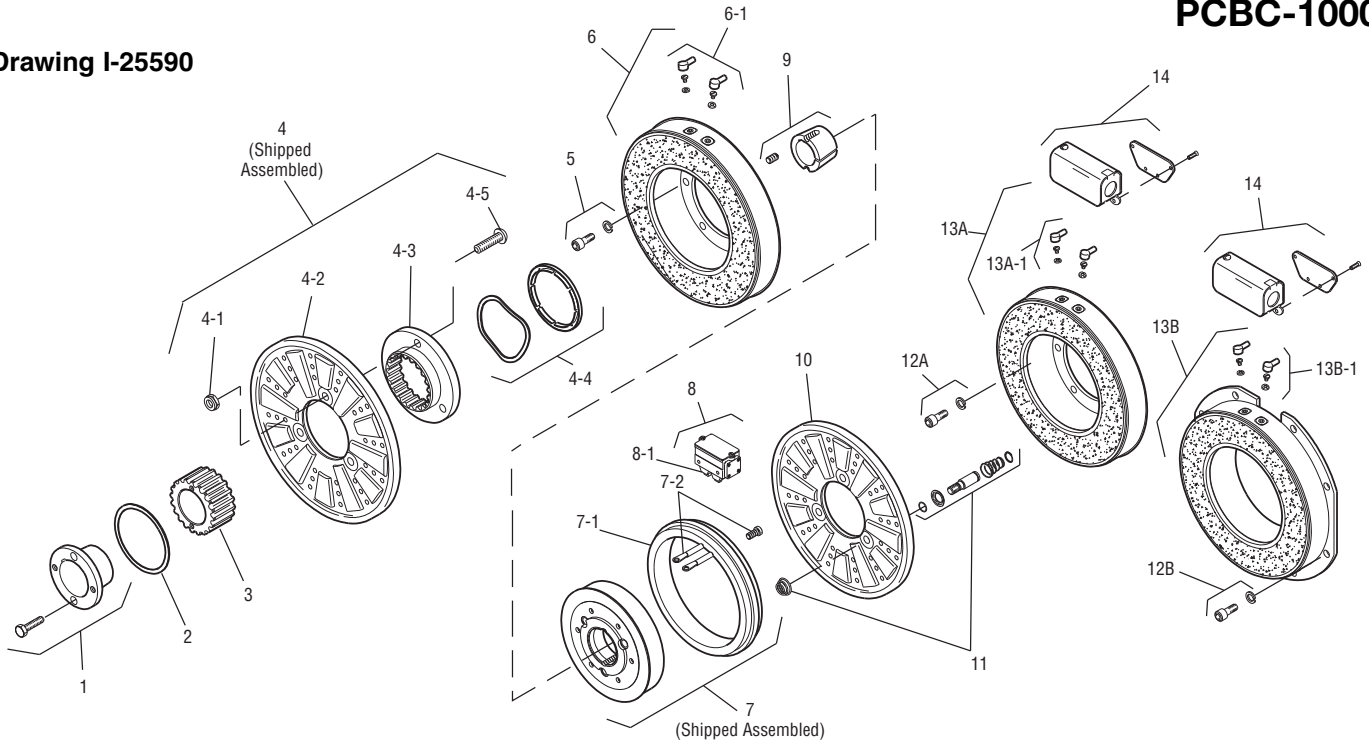

Item	Description	Part Number	Qty.
1	Bushing*		1
	3/4" to 2-11/16" Bore	180-0026 to 180-0057	
2	Retainer Ring	748-0007	1
3	Splined Hub	540-0062	1
4	Armature & Splined Adapter	5322-111-002	1
4-1	Locknut	661-0004	3
4-2	Armature	5322-111-036	1
4-3	Splined Adapter	104-0009	1
4-4	Autogap Accessory	5322-101-004	1
4-5	Screw	797-0272	3
5	Mounting Accessory	5321-101-001	1
6	Magnet		1
	6 Volt	5302-631-003	
	24 Volt	5302-631-014	
	90 Volt	5302-631-005	
6-1	Terminal Accessory	5311-101-001	1
7	Magnet Hub		1
	Left Hand (shown)	5302-541-001	
	Right Hand	5302-541-002	
7-1	Collector Ring	5301-749-001	1
7-2	Collector Ring Accessory	5302-101-002	1
8	Brushholder	5300-178-001	1
8-1	Brush	176-0001	4
9	Bushing*		1
	1/2" to 2-1/2" Bore	180-0185 to 180-0217	
10	Armature	5302-111-013	1
11	Autogap Accessory	5201-101-008	3
12A	Mounting Accessory - I.M.	5321-101-001	1
12B	Mounting Accessory - O.M.	5321-101-002	2

Item	Description	Part Number	Qty.
13A	Magnet - Inside Mounted		1
	6 Volt	5312-631-004	
	24 Volt	5312-631-005	
	90 Volt	5312-631-006	
13A-1	Terminal Accessory	5311-101-001	1
13B	Magnet - Outside Mounted		1
	6 Volt	5312-631-011	
	24 Volt	5312-631-013	
	90 Volt	5312-631-012	
13B-1	Terminal Accessory	5311-101-001	1
14	Conduit Box	5200-101-011	1

### How to Order:

1. Specify Bore Size for Items 1 and 9.
2. Specify Voltage for Items 6 and 13.
3. Specify left hand or right hand hub for Item 7. Bushing enters from magnet side for L.H. hub and from hub side for R.H.
4. Specify Inside Mounted for Items 12A and 13A or Outside Mounted for Items 12B and 13B.
5. See Controls Section.

### Example:

PCBC-1000 Clutch Brake Coupling per I-25590 - 90 Volt, Inside Mounted, Left Hand hub, 1-1/2" Bore, ( Items 1 and 9)

These units meet the standards of UL508 and are listed under guide card #NMTR2, file #59164. These units are CSA certified under file #LR11543.

\*See page 252 for specific part numbers.

Refer to Service Manual P-205.

# Clutch/Brake Coupling

## PCBC-1225/1000

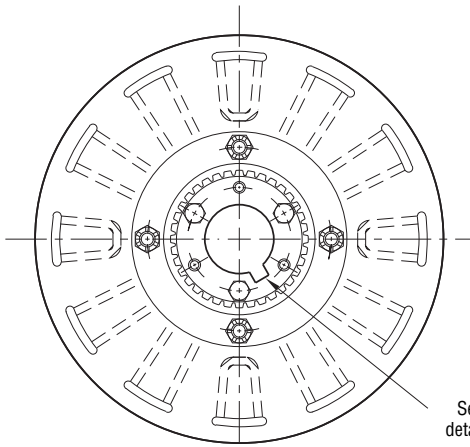

**ARMATURE VIEW**

See page 252 for details on Bushings.

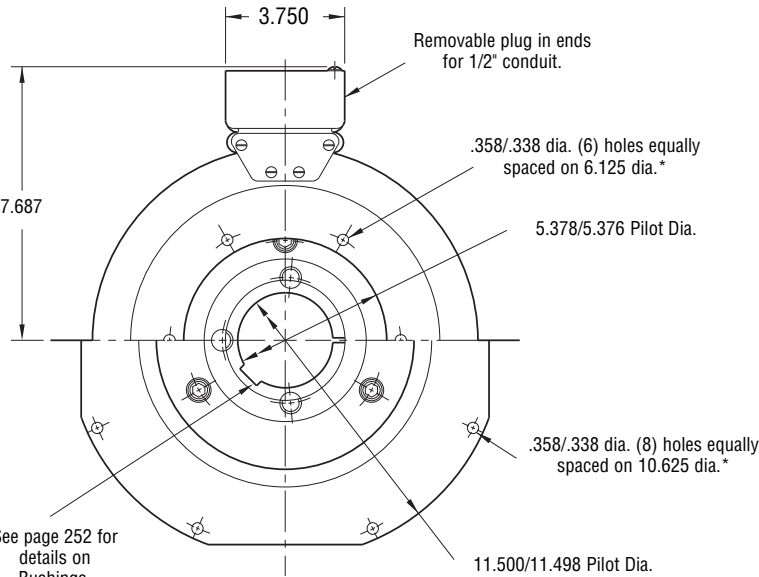

**MAGNET VIEW  
(Inside & Outside Mounted)**

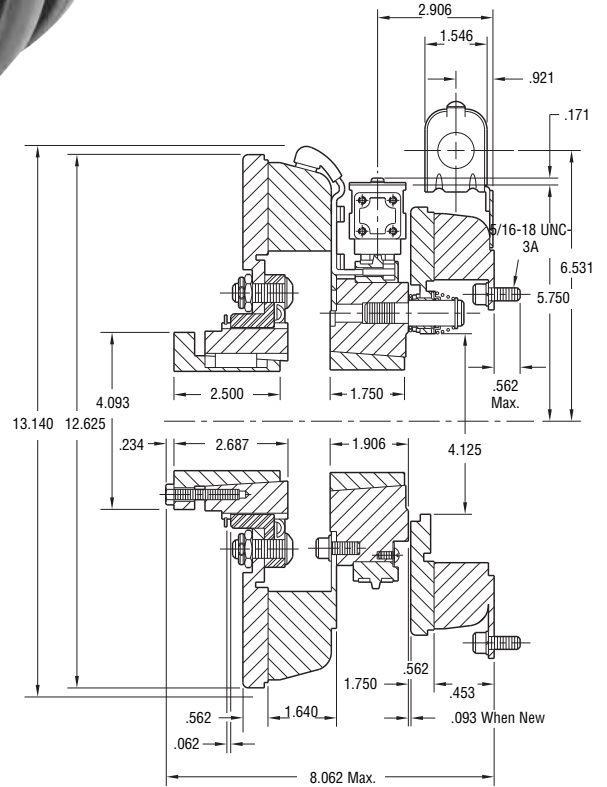

\* Mounting holes are within .010 of true position relative to pilot diameter.

### Customer Shall Maintain:

1. Armature mounting shaft concentric with magnet mounting shaft within .006 T.I.R.
2. Squareness of brake magnet mounting face with magnet mounting shaft within .006 T.I.R.
3. Concentricity of brake magnet mounting pilot diameter with magnet mounting shaft within .010 T.I.R.

Armature Shaft	.750 – 2.687
Magnet Shaft	.500 – 2.500
Static Torque Clutch	465 lb.ft.
Static Torque Brake	240 lb.ft.
Maximum Speed	3,000 rpm
Standard Voltage	D.C. 6, 90

All dimensions are nominal unless otherwise noted.

Information on inertia and weights begins on page 239. Coil data is on pages 250 and 251.





Drawing I-25613

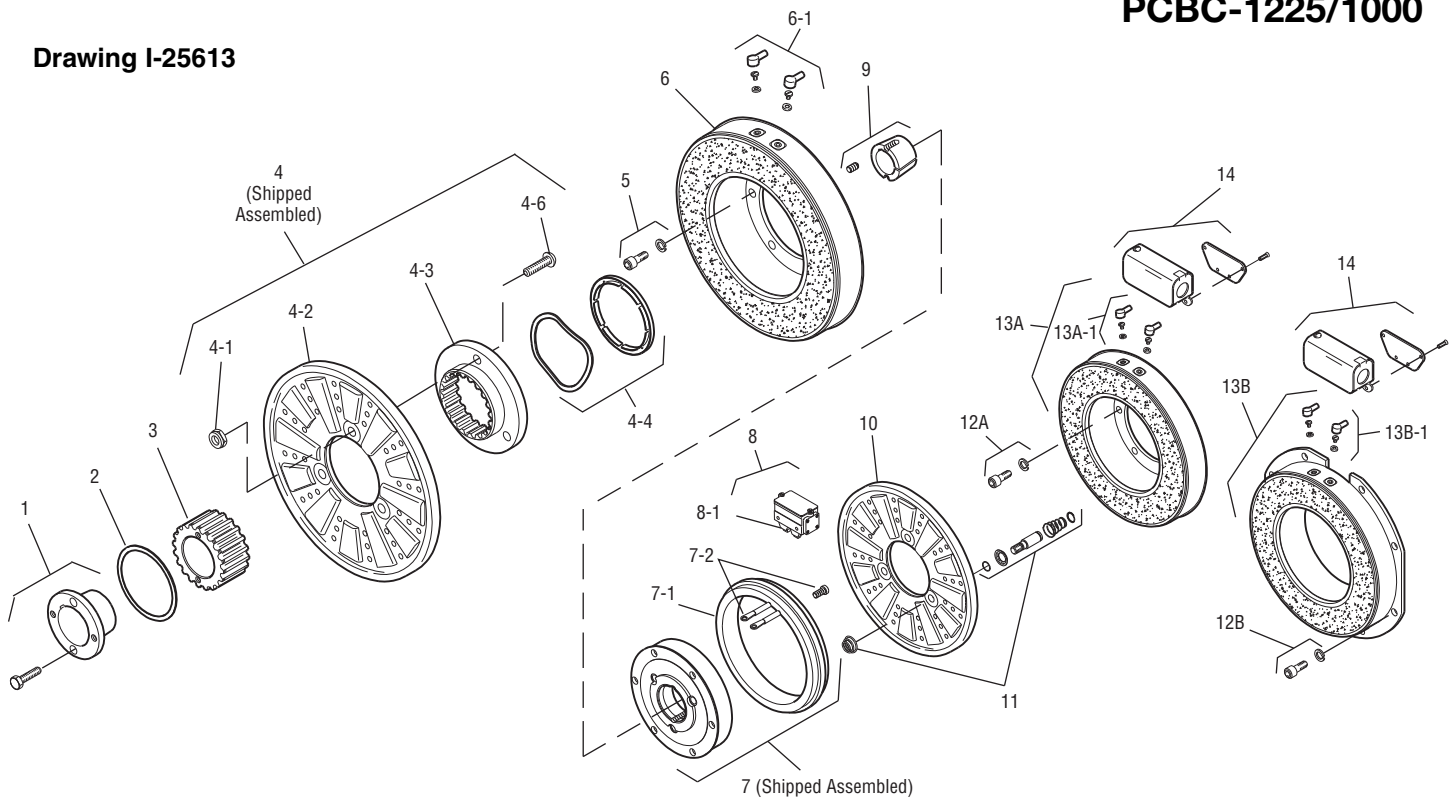

Item	Description	Part Number	Qty.
1	Bushing*		1
	3/4" to 2-11/16" Bore	180-0026 to 180-0057	
2	Retainer Ring	748-0005	1
3	Splined Hub	540-0064	1
4	Armature & Splined Adapter	5323-111-001	1
4-1	Locknut	661-0005	4
4-2	Armature	5323-111-034	1
4-3	Splined Adapter	104-0010	1
4-4	Autogap Accessory	5323-101-002	1
4-6	Screw	797-0281	4
5	Mounting Accessory	5321-101-001	1
6	Magnet		1
	6 Volt	5333-631-008	
	90 Volt	5333-631-009	
	†90 Volt LK Facing	5333-631-013	
6-1	Terminal Accessory	5311-101-001	1
7	Magnet Hub		1
	Left Hand (shown)	5302-541-004	
	Right Hand	5302-541-005	
7-1	Collector Ring	5301-749-001	1
7-2	Collector Ring Accessory	5303-101-004	1
8	Brushholder	5300-178-001	1
8-1	Brush	176-0001	4
9	Bushing*		1
	1/2" to 2-1/2" Bore	180-0185 to 180-0217	
10	Armature	5302-111-013	1
11	Autogap Accessory	5201-101-008	3
12A	Mounting Accessory - I.M.	5321-101-001	1

Item	Description	Part Number	Qty.
12B	Mounting Accessory - O.M.	5321-101-002	2
13A	Magnet - Inside Mounted		1
	6 Volt	5312-631-004	
	90 Volt	5312-631-006	
13A-1	Terminal Accessory	5311-101-001	1
13B	Magnet - Outside Mounted		1
	6 Volt	5312-631-011	
	90 Volt	5312-631-012	
13B-1	Terminal Accessory	5311-101-001	1
14	Conduit Box	5200-101-011	1

### How to Order:

1. Specify Bore Size for Item 1 and 9.
2. Specify Voltage for Item 6 and Item 13A or 13B.
3. Specify left hand or right hand hub for Item 7. Bushing enters from magnet side for L.H. hub and from hub side for R.H.
4. Specify Inside Mounted for Items 12A and 13A or Outside Mounted for Items 12B and 13B.
5. See Controls Section.

### Example:

PCBC-1225/1000 Clutch Brake Coupling per I-25613 - 90 Volt, Inside Mounted, Left Hand hub, 1-3/4" Bore, ( Items 1 and 9).

These units meet standards set forth in UL508 and are listed under guide card #NMTR2, file #59164. These units are CSA certified under file #LR11543.

\*See page 252 for specific part numbers.

Refer to Service Manual P-214.

†Optional LK facing available. For more information, see page 232.

# Clutch/Brake Coupling

## PCBC-1225

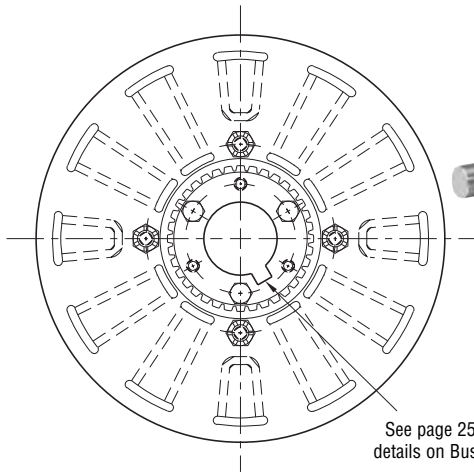
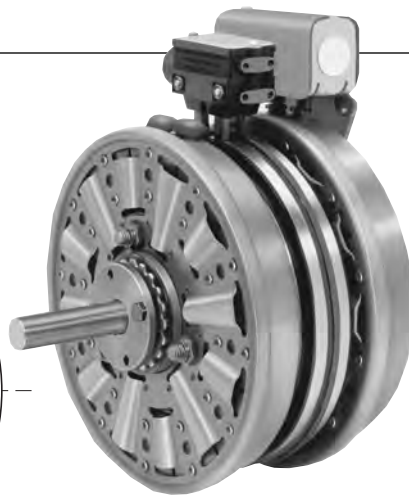

**ARMATURE VIEW**

See page 252 for details on Bushings.

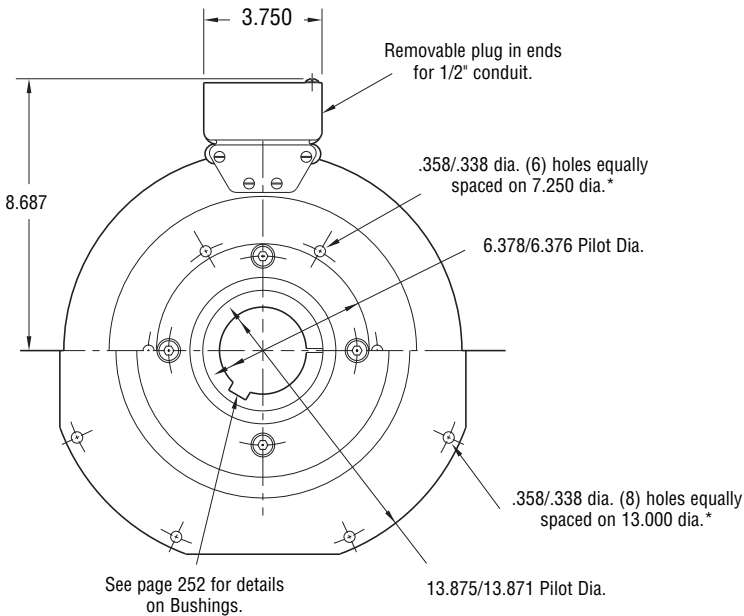

**MAGNET VIEW  
(Inside & Outside Mounted)**

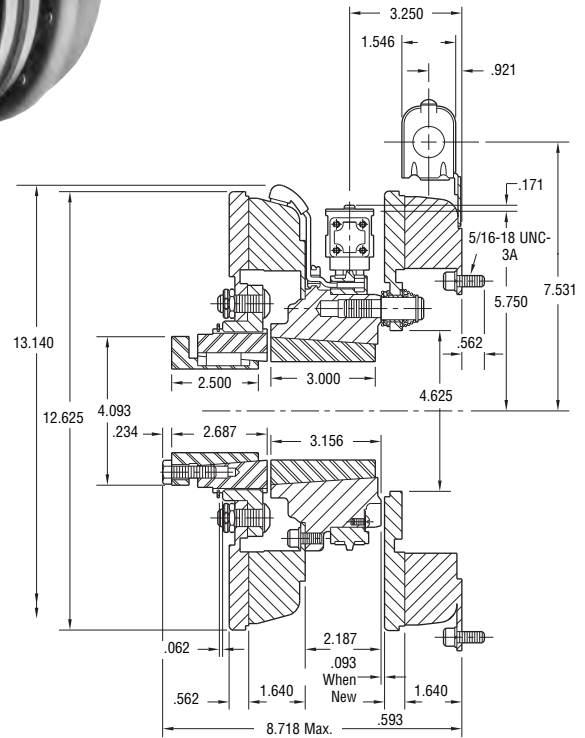

\* Mounting holes are within .010 of true position relative to pilot diameter.

### Customer Shall Maintain:

1. Armature mounting shaft concentric with magnet mounting shaft within .006 T.I.R.
2. Squareness of brake magnet mounting face with magnet mounting shaft within .006 T.I.R.
3. Concentricity of brake magnet mounting pilot diameter with magnet mounting shaft within .010 T.I.R.
4. Angular alignment of shafts within 1/2 degree.

Armature Shaft	.750 – 2.687
Magnet Shaft	.937 – 3.000
Static Torque	465 lb.ft.
Maximum Speed	3,000 rpm
Standard Voltage	D.C. 6, 24, 90

All dimensions are nominal unless otherwise noted.

Information on inertia and weights begins on page 239. Coil data is on pages 250 and 251.



Drawing I-25612

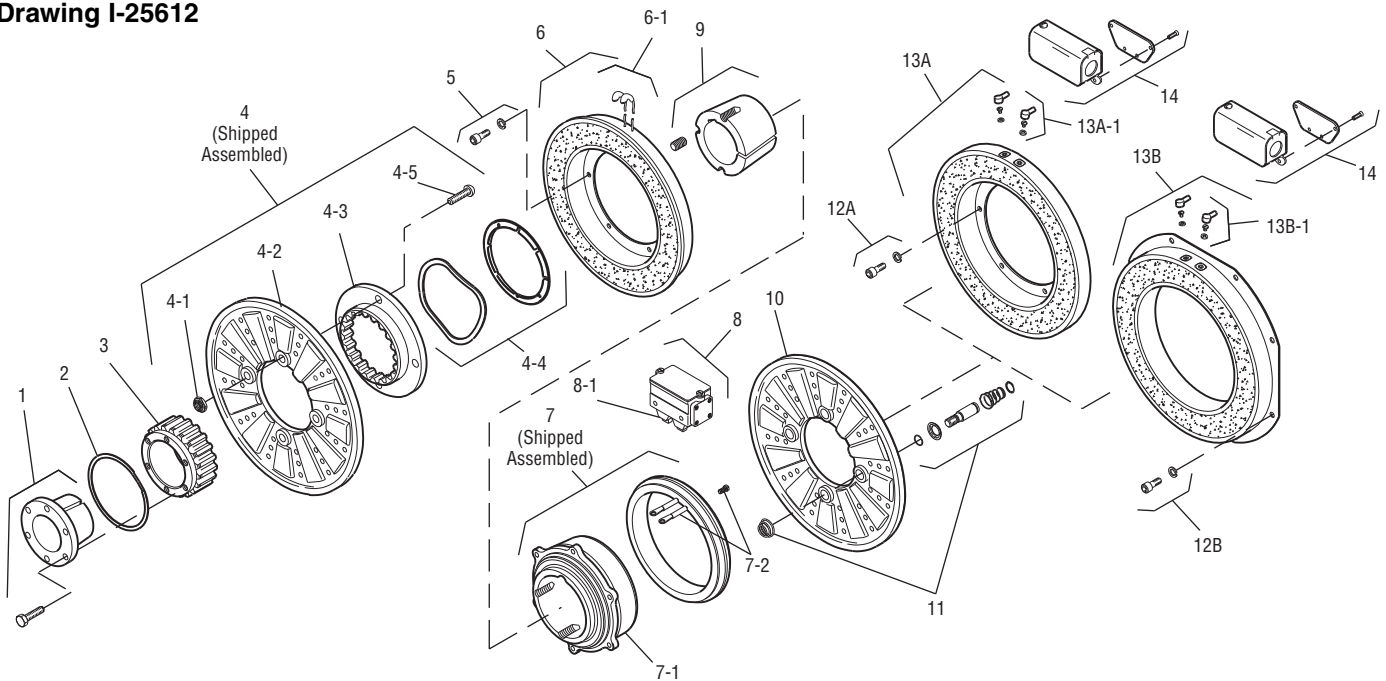

Item	Description	Part Number	Qty.
1	Bushing*		1
	3/4" to 2-11/16" Bore	180-0026 to 180-0057	
2	Retainer Ring	748-0005	1
3	Splined hub	540-0064	1
4	Armature & Splined Adapter	5323-111-001	1
4-1	Locknut	661-0005	4
4-2	Armature	5323-111-034	1
4-3	Splined Adapter	104-0010	1
4-4	Autogap Accessory	5323-101-002	1
4-5	Screw	797-0281	4
5	Mounting Accessory	5321-101-001	1
6	Magnet		1
	6 Volt	5303-631-005	
	24 Volt	5303-631-007	
	90 Volt	5303-631-008	
6-1	Terminal Accessory	5311-101-001	1
7	Magnet Hub		1
	Left Hand (shown)	5303-541-001	
	Right Hand	5303-541-002	
7-1	Collector Ring	5301-749-001	1
7-2	Collector Ring Assembly	5303-101-004	1
8	Brushholder	5300-178-001	1
8-1	Brush	176-0001	4
9	Bushing*		1
	15/16" to 3" Bore	180-0262 to 180-0295	
10	Armature	5303-111-009	1
11	Autogap Accessory	5201-101-008	4
12A	Mounting Accessory - I.M.	5321-101-001	1
12B	Mounting Accessory - O.M.	5321-101-002	2

Item	Description	Part Number	Qty.
13A	Magnet - Inside Mounted		1
	6 Volt	5313-631-005	
	24 Volt	5313-631-006	
	90 Volt	5313-631-007	
13A-1	Terminal Accessory	5311-101-001	1
13B	Magnet - Outside Mounted		1
	6 Volt	5313-631-010	
	24 Volt	5313-631-012	
	90 Volt	5313-631-011	
13B-1	Terminal Accessory	5311-101-001	1
14	Conduit Box	5200-101-011	1

### How to Order:

1. Specify Bore Size for Items 1 and 9.
2. Specify Voltage for Items 6 and 13.
3. Specify left hand or right hand hub for Item 7. Bushing enters from magnet side for L.H. hub and from hub side for R.H.
4. Specify Inside Mounted for Items 12A and 13A or Outside Mounted for Items 12B and 13B.
5. See Controls Section.

### Example:

PCBC-1225 Clutch Brake Coupling per I-25612 - 90 Volt, Inside Mounted Left Hand hub, 1-3/4" Bore ( Items 1 and 9)

These units meet the standards of UL508 and are listed under guide card #NMTR2, file #59164. These units are CSA certified under file #LR11543.

\*See page 252 for specific part numbers.

Refer to Service Manual P-205.

# Clutch/Brake Coupling

## PCBC-1525/1225

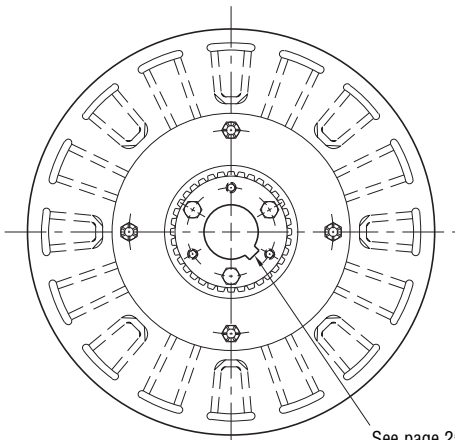

**ARMATURE VIEW**

See page 252 for details on Bushings.

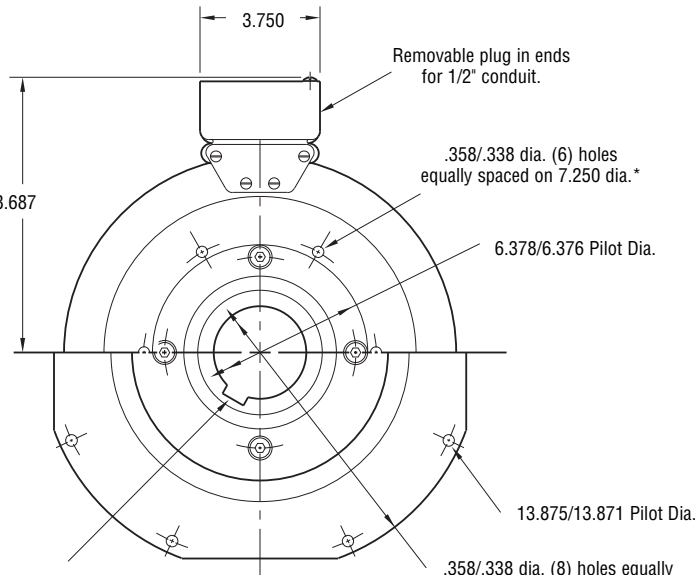
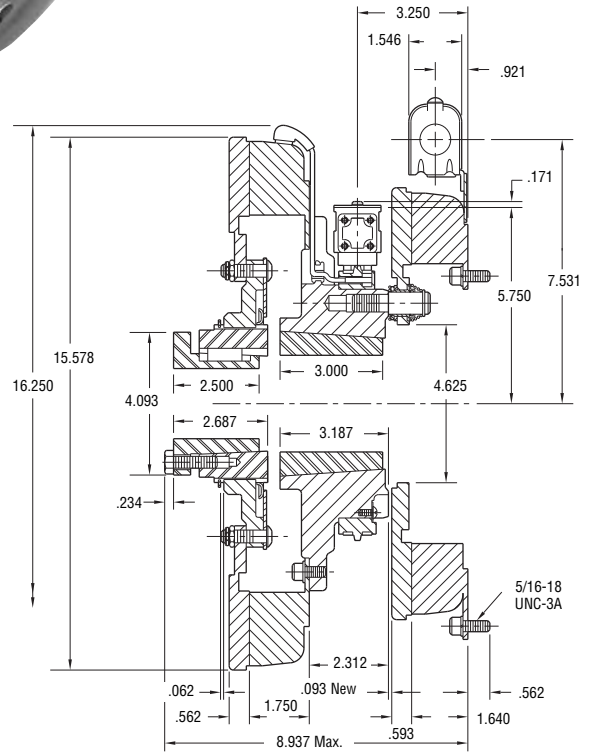

**MAGNET VIEW  
(Inside & Outside Mounted)**

See page 252 for details on Bushings.

\* Mounting holes are within .010 of true position relative to pilot diameter.

### Customer Shall Maintain:

1. Armature mounting shaft concentric with magnet mounting shaft within .006 T.I.R.
2. Squareness of brake magnet mounting face with magnet mounting shaft within .006 T.I.R.
3. Concentricity of brake magnet mounting pilot diameter with magnet mounting shaft within .010 T.I.R.

Armature Shaft	.750 – 2.687
Magnet Shaft	.937 – 3.000
Static Torque Clutch	700 lb.ft.
Static Torque Brake	465 lb.ft.
Maximum Speed	2,000 rpm
Standard Voltage	D.C. 6, 24, 90

All dimensions are nominal unless otherwise noted.

Information on inertia and weights begins on page 239. Coil data is on pages 250 and 251.



# Clutch/Brake Coupling

## PCBC-1525/1225

Drawing I-25637

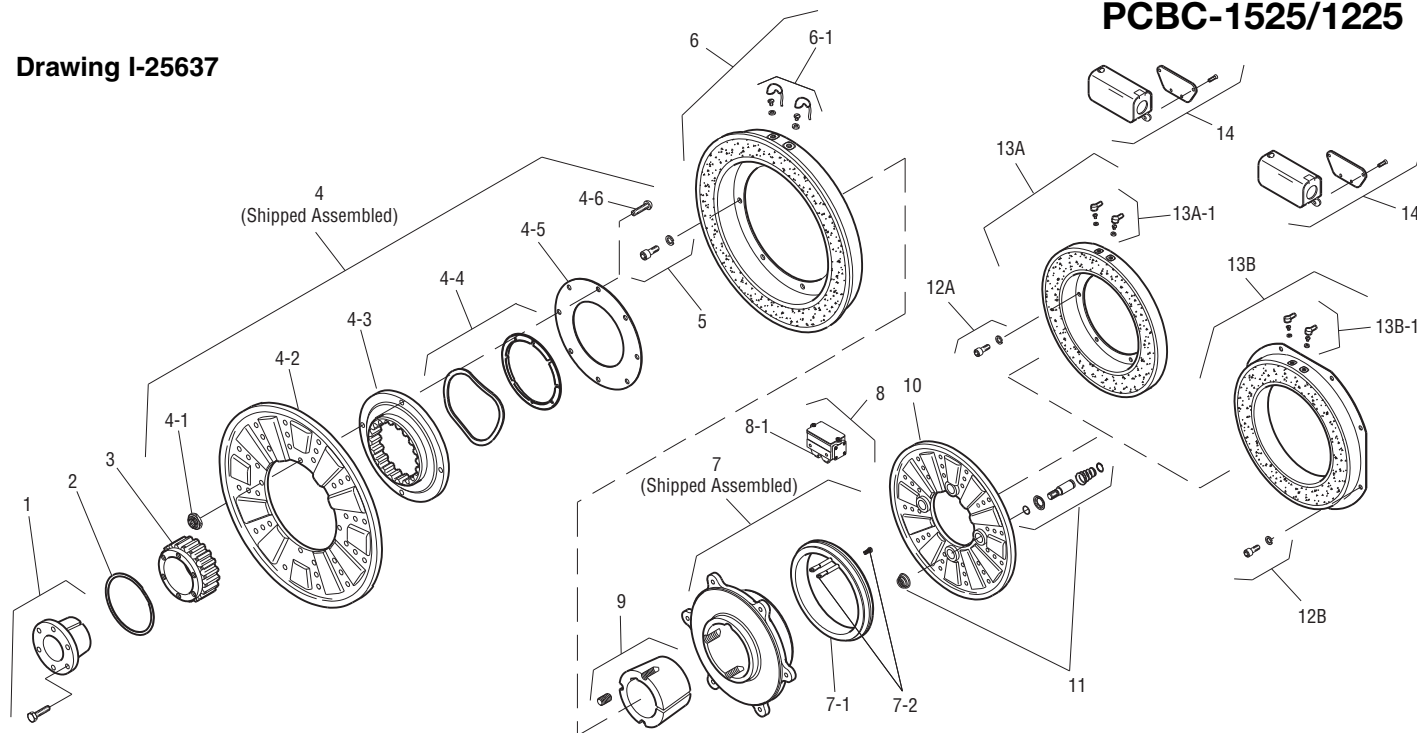

Item	Description	Part Number	Qty.
1	Bushing*		1
	3/4" to 2-11/16" Bore	180-0026 to 180-0057	
2	Retainer Ring	748-0005	1
3	Splined Hub	540-0064	1
4	Armature & Splined Adapter	5324-111-001	1
4-1	Locknut	661-0004	8
4-2	Armature	5324-111-034	1
4-3	Splined Adapter	104-0011	1
4-4	Autogap Accessory	5323-101-002	1
4-5	Retainer Plate	686-0003	1
4-6	Screw	797-0272	8
5	Mounting Accessory	5321-101-001	2
6	Magnet		1
	6 Volt	5304-631-009	
	24 Volt	5304-631-011	
	90 Volt	5304-631-010	
6-1	Terminal Accessory	5311-101-001	1
7	Magnet Hub		1
	Left Hand (shown)	5304-541-001	
	Right Hand	5304-541-002	
7-1	Collector Ring	5301-749-001	1
7-2	Collector Ring Accessory	5304-101-004	1
8	Brushholder	5300-178-001	1
8-1	Brush	176-0001	4
9	Bushing*		1
	15/16" to 3" Bore	180-0262 to 180-0295	
10	Armature	5303-111-009	1
11	Autogap Accessory	5201-101-008	4
12A	Mounting Accessory - I.M.	5321-101-001	1

Item	Description	Part Number	Qty.
12B	Mounting Accessory - O.M.	5321-101-002	2
13A	Magnet - Inside Mounted		1
	6 Volt	5313-631-005	
	24 Volt	5313-631-006	
	90 Volt	5313-631-007	
13A-1	Terminal Accessory	5311-101-001	1
13B	Magnet - Outside Mounted		1
	6 Volt	5313-631-010	
	24 Volt	5313-631-012	
	90 Volt	5313-631-011	
13B-1	Terminal Accessory	5311-101-001	1
14	Conduit Box	5200-101-010	1

### How to Order:

1. Specify Bore Size for Items 1 and 9.
2. Specify Voltage for Item 6 and 13A or 13B.
3. Specify left hand or right hand hub for Item 7. Bushing enters from magnet side for L.H. hub and from hub side for R.H.
4. Specify Inside Mounted for Items 12A and 13A or Outside Mounted for Items 12B and 13B.
5. See Controls Section.

### Example:

PCBC-1525/1225 Clutch Brake Coupling per I-25637 - 90 Volt, Inside Mounted, Left Hand hub, 2" Bore (Items 1 and 9)

These units meet the standards of UL508 and are listed under guide card #NMTR2, file #59164. These units are CSA certified under file #LR11543.

\*See page 252 for specific part numbers.

Refer to Service Manual P-214.



<b>Drive Pin Mounting</b> .....	230
<b>Autogap Applications</b> .....	231
<b>LK Friction Material</b> .....	232
<b>Theory of Operation</b> .....	233
<b>Dynamic Torque Curves</b> .....	234
<b>Heat Dissipation Formulae</b> .....	236
<b>Heat Dissipation Curves</b> .....	237
<b>Inertia Values</b> .....	238
<b>Weights and Inertias</b> .....	239
<b>Rotational Speed/Burnishing</b> .....	244
<b>Clutch Field Restraining Devices/Torque Arms</b> .....	245
<b>UL/UR/CSA</b> .....	246
<b>Cycle Rate Curves</b> .....	247
<b>Electrical Coil Ratings</b> .....	248
<b>Electrical Installation Recommendations</b> .....	249
<b>Coil Suppression and Overlap</b> .....	250
<b>Overexcitation</b> .....	251
<b>Bushing Part Numbers</b> .....	252
<b>Conversion Factors</b> .....	254
<b>Glossary of Terms</b> .....	255
<b>Ordering Information</b> .....	257
<b>Clutch and Brake Controls</b> .....	261

## Machining instructions for gear, sprocket or pulley

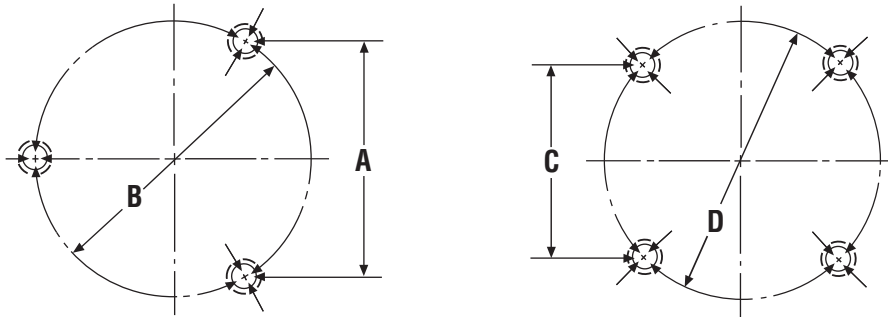

Unit Size	A	B	C	D
500	3.356 ± .001	3.875 ± .001		
650			3.624 ± .001	5.125 ± .001
825	3.085 ± .001	3.563 ± .001		
1000	4.548 ± .002	5.252 ± .002		
1225			4.155 ± .002	5.877 ± .002
1525			6.010 ± .002	8.500 ± .002

1. Chordal dimensions must be held for all chords between pin holes.

### Size 825-1525

2. Drill 27/64 inch diameter holes to a sufficient depth and tap for 1/2-13 UNC-3B, one inch minimum full threads. Pin holes must be concentric with mounting shaft within .010 T.I.R. and parallel with mounting shaft within .002 T.I.R., surface that pins seat against to be square with mounting shaft within .004 T.I.R.
3. Ream .500/.501 to a 3/8 inch depth and to be concentric with tapped holes.

### Size 500 and 650

4. Sleeve bearings (oilite bronze) must be provided in the holes of pulley or hub with an I.D. of .376 ± .001 at the chordal and bolt circle dimensions shown above.
5. The drive pin holes must be concentric with mounting shaft within .006 T.I.R. and parallel with mounting shaft within .002 T.I.R.

### Size 500-650 Drive Pin

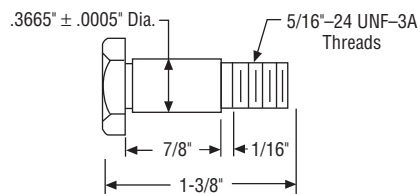

### Size 825-1525 Drive Pin

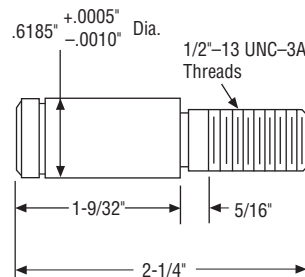



## Autogaps – When Not To Use

The Autogap is a system designed to separate the armature from the friction face. This spacing is automatic and occurs prior to total magnetic decay, effectively eliminating noise by preventing drag. Although Autogaps are desirable and necessary in the vast majority of applications, they should be removed when using over-excitation controls for fast response and high accuracy or when very soft starts and stops with low voltage to the clutch or brake are required. Removing the Autogap assembly closes the gap between the armature and magnet or field, resulting in reduced engagement time, improved repeatability, and the ability to engage the armature at very low voltage settings required for very soft starts and stops.

## Pin Drive Applications

On pin drive armatures, the Autogap can be removed by taking out the entire assembly except the armature backup spring, which should remain in place to slightly preload the armature against the friction face. On Electro-Modules, the Autogap device is contained within the retaining cup screwed onto each armature.



To disable the assembly, only the Autogap spring should be removed and the balance of the cup contents should be reinstalled. With spline drives, the Autogap system must first be removed and then the detent spring should be placed directly behind the armature to prevent spinback from vibration.

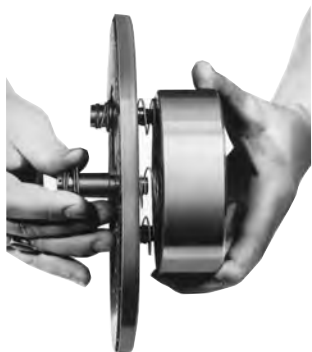

## Heavy Duty Spline Drive Autogaps

Warner Electric's patented Autogap system is the reason Warner Electric clutches and brakes require no adjustment and offer consistent performance throughout the life of the unit. Without a wear take-up system, armature and magnet or rotor wear will eventually prevent the magnet coil from "pulling in" the armature and the clutch or brake will fail to respond when energized. A wear compensating system which maintains a constant, optimal space between the armature and the magnet or rotor is necessary to achieve consistent performance without manual adjustment.

Spline drive hubs which utilize the Autogap system pictured are found on all Warner Electric heavy duty Custom Design clutches and brakes, as well as Electro Modules, Electro Packs and Advanced Technology (AT) clutches and brakes.

## How They Work

As material wears off the magnet or rotor and armature during operation, gap "X" increases. When the clutch or brake is energized, the armature is magnetically pulled to the magnet or rotor. If gap "X" is larger than gap "Y", the lip on the retainer plate will push on the detent ring overcoming the grip force between the detent ring and outside diameter of the splined hub, moving the detent ring. This adjusts gap "X" to be the same as gap "Y", and will maintain that gap over the life of the unit. When the unit is de-energized, the spring pushes against the detent ring and the retainer plate, which is secured to the armature. The armature assembly automatically moves away from the magnet or rotor by gap "X" each time the clutch or brake is cycled.

## How to Set

If the armature does not engage when the unit is energized, gap "X" has increased to a point where the magnetic pull cannot overcome the excess gap. This can happen with excess vibration or

## Autogap® Application

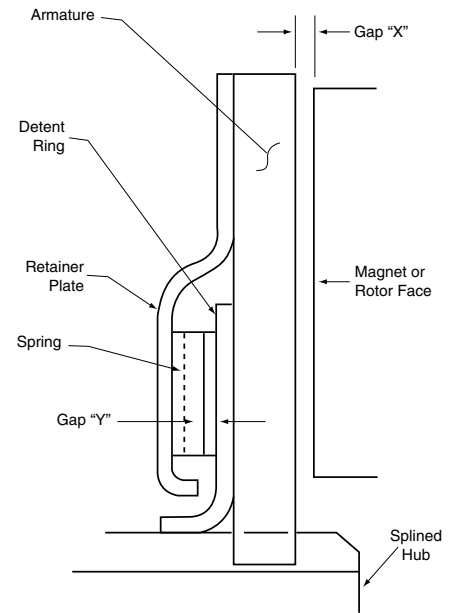

mishandling. To reset the autogap, move the armature assembly toward the magnet or rotor. This can be done by 1) or 2) below:

- 1) Preferable – If an adjustable power supply is available, voltage can be increased for a short time to overcome the excess gap and pull the armature in to reset the gap.
- 2) If increased voltage is not available or is inadequate, the armature must be manually pushed toward the magnet or rotor until available voltage will pull it in. Slots are provided in electromodule fans for access to the armatures. When pushing the armature, the force must be applied against the retainer plate outer ring and not against the detent ring itself.

If the detent ring has been moved too close to the magnet or rotor, reducing gap "X" and causing drag, the armature must be manually moved away from the unit and then be readjusted as described above.

## LK Friction Material

Warner Electric offers a special low coefficient (LK) friction material for many standard clutches and brakes. Since two friction materials are available, a comparison of LK to standard is in order.

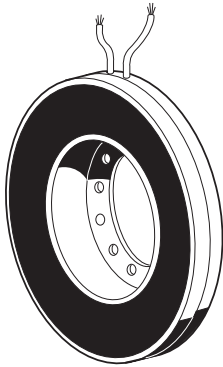

Since LK has a lower coefficient of friction, lower torque capability results. With LK facing, static torque capacity is only about 60% of catalog rating for any given size. So if a specific size clutch or brake is chosen for its rated torque capacity and LK facings are substituted for standard, a larger size unit will be needed to provide the same torque.

If lower torque ratings can be considered a disadvantage, what are the advantages of LK material? The first is longer life. An ideal situation for LK use is a constant slip application which requires a large unit for high heat dissipation. Another feature of LK is "softer" pickup. Since more slippage will occur, engagement time is increased and shock is reduced. LK material will also reduce engagement noise, so it can be successfully employed where high

noise levels are a problem. It is the standard facing in all tension brakes and motor brake magnets. LK has been a popular special feature for many years, enabling us to offer it in the following sizes with no special handling charge. Delivery can usually be made in 30 days, and quite often immediately from our stock. No hard and fast rules can be written to cover LK application, but this option can be used to solve application problems. For price, delivery, and further information, contact your Warner Electric Distributor.

LK can be added to any magnet or rotor. For those not shown below added lead time and cost will be required. Consult factory for additional details.

### Stationary Field Clutches

Description	Page No.	Replaces Standard	
		Rotor Part No.- LK	Rotor
SF-825, F.M., N.D.	36	5201-751-007	5201-751-003
SF-825, F.M., H.D.	40	5201-751-007	5201-751-003
SFC-825, F.M.	114	5201-751-007	5201-751-003
SF-1000, F.M., N.D.	44	5202-751-007	5202-751-003
SF-1000, F.M., H.D.	48	5202-751-007	5202-751-003
SFC-1000, F.M.	118	5202-751-007	5202-751-003
SF-1000, B.M., N.D.	46	5202-751-007	5202-751-003
SF-1000, B.M., H.D.	50	5202-751-007	5202-751-003
SFC-1000, B.M.	120	5202-751-007	5202-751-003
SF-1225, F.M., N.D.	52	5203-751-004	5203-751-001
SF-1225, F.M., H.D.	54	5203-751-004	5203-751-001
SFC-1225, F.M.	122	5203-751-004	5203-751-001
SF-1225, B.M., N.D.	56	5203-751-004	5203-751-001
SF-1225, B.M., H.D.	58	5203-751-004	5203-751-001
SFC-1225, B.M.	124	5203-751-004	5203-751-001
SF-1525, F.M., N.D.	60	5204-751-004	5204-751-002
SF-1525, F.M., H.D.	62	5204-751-004	5204-751-002
SFC-1525, F.M.	126	5204-751-004	5204-751-002
SF-1525, B.M., N.D.	64	5204-751-004	5204-751-002
SF-1525, B.M., H.D.	66	5204-751-004	5204-751-002
SFC-1525, B.M.	128	5204-751-004	5204-751-002

### How to Order:

Specify "LK facing" and substitute LK part number for standard part number.

### Primary Clutches

Description	Page No.	Replaces Standard	
		Magnet Part No.- LK	Magnet No.
PC-825, N.D., 90V	74	5301-631-011	5301-631-005
PC-825, H.D., 90V	76	5301-631-011	5301-631-005
PC-1000, N.D., 90V	78	5302-631-001	5302-631-005
PC-1000, H.D., 90V	80	5302-631-001	5302-631-005
PC-1225, N.D., 90V	82	5303-631-001	5303-631-008
PC-1225, H.D., 90V	84	5303-631-001	5303-631-008
PC-1525, N.D., 90V	86	5304-631-002	5304-631-010
PC-1525, H.D., 90V	88	5304-631-002	5304-631-010

### Primary Brakes

Description	Page No.	Replaces Standard	
		Magnet Part No.- LK	Magnet No.
PB-825, N.D., 90V	160	5311-631-011	5311-631-004
PB-825, H.D., 90V	162	5311-631-011	5311-631-004
PB-1000, N.D., 90V	164	5312-631-001	5312-631-006
PB-1000, H.D., 90V	166	5312-631-001	5312-631-006
PB-1225, N.D., 90V	168	5313-631-001	5313-631-007
PB-1225, H.D., 90V	170	5313-631-001	5313-631-007
PB-1525, N.D., 90V	172	5314-631-001	5314-631-005
PB-1525, H.D., 90V	174	5314-631-001	5314-631-005

### Clutch/Brake Combinations

Description	Page No.	Replaces Standard	
		Magnet Part No.- LK	Magnet No.
PCB-1225/1000, N.D., 90V	196	5333-631-013	5333-631-009
PCB-1225/1000, H.D., 90V	198	5333-631-013	5333-631-009

Warner Electric designed product uses electromagnetism to engage the clutches and brakes. When electric current is passed through a wire, lines of magnetic flux are created. Warner Electric uses coils of wire embedded into a C-shaped iron "shell". When the electrical current is passed through the coil the shell is magnetized with the magnetism concentrating at the ends of the shell. These are also called "poles". When a steel or iron plate is close to the poles it is attracted to them, and the two pieces clamp together. To accomplish stable operation, DC power is required for electric clutches and brakes.

In a PC type clutch or a brake, a cross section will appear like Figure 1. When DC power is applied a magnetic field causes the armature to clamp against the magnet. Since magnetism is the engaging force, it is appropriate in Warner Electric designs for the metal poles of the magnet to engage directly against the metal plate of the armature. Friction material is included in industrial clutches and brakes to provide longer life, greater heat dissipation and to reduce noise during engagement.

SF style clutches (Figure 2) have a stationary field and rotor in place of the magnet. They function in a similar manner. When current is applied to the field coil, magnetism is created. The magnetism travels to the rotor face where it engages the armature.

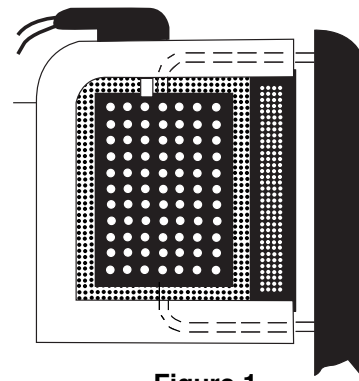

Figure 1

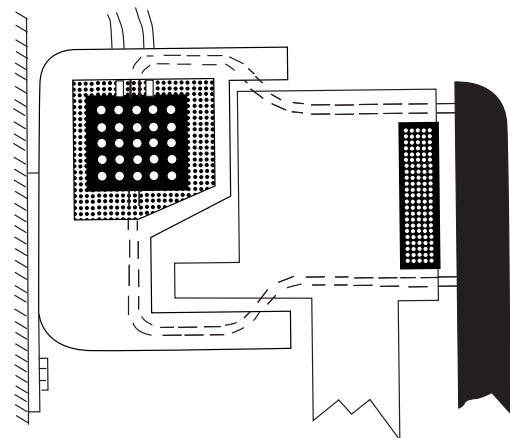

Figure 2

## Dynamic Torque

### NOTES:

Speed difference means the difference in speed between one friction face and the other at the moment of engagement. The intersection of the top curve and the speed difference is the maximum torque produced by the unit. When both friction faces are engaged and rotating at the same speed, the unit is said to be locked-in and produces the maximum static torque (zero speed difference).

The % lines indicate the percentage of full voltage being used. Example: If 90 volt unit runs at 45 volts, use the 50% line.

Average Torque = Dynamic Torque at  $1/2$  operating speed. Example: If operating speed is 1800, use dynamic torque at 900.

**Size 120** Maximum Speed 10,000 rpm  
Static Torque 5 lb./in.

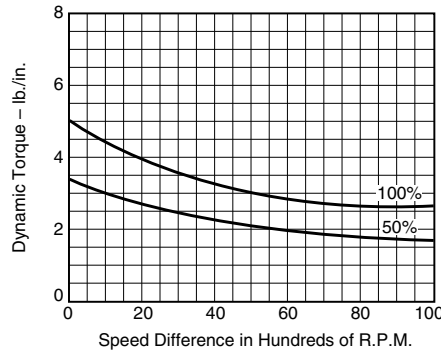

**Size 170** Maximum Speed 10,000 rpm  
Static Torque 15 lb./in.

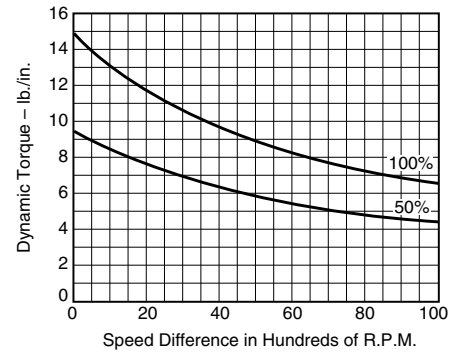

**Size 250** Maximum Speed 7,500 rpm  
Static Torque 70 lb./in.

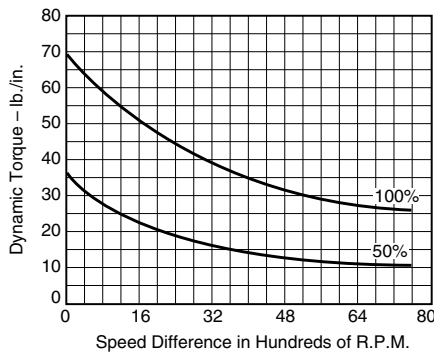

**Size 400** Maximum Speed 4,500 rpm  
Static Torque 270 lb./in.

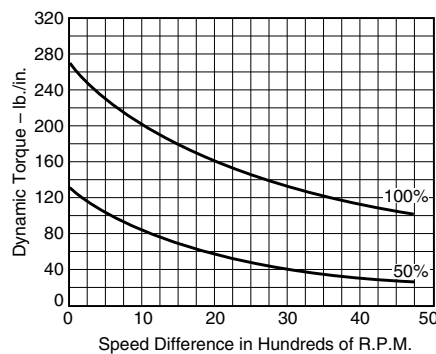

**Size 500-SF** Maximum Speed 4,000 rpm  
Static Torque 50 lb./ft.

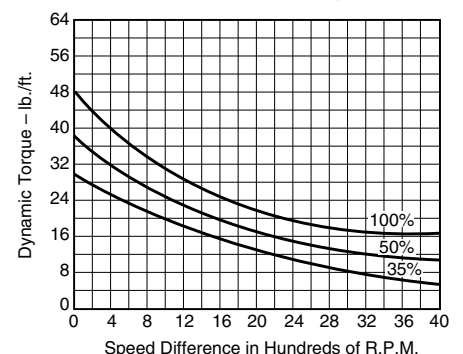

**Size 500-PC/PB** Maximum Speed 5,400 rpm  
Static Torque 40 lb./ft.

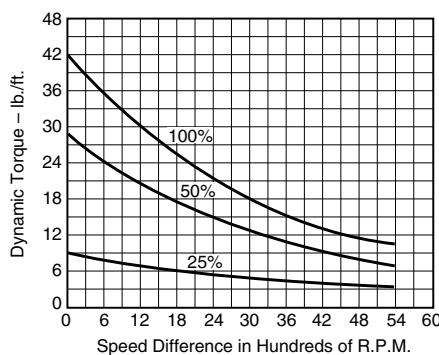

**Size 650** Maximum Speed 3,600 rpm  
Static Torque 95 lb./ft.

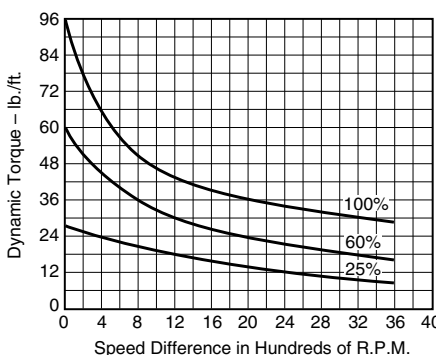

**Size 825-SF** Maximum Speed 3,600 rpm  
Static Torque 150 lb./ft.

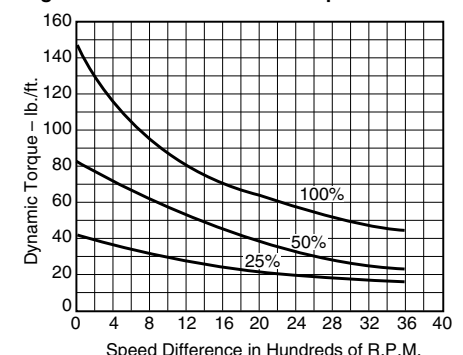

**NOTE:** Torque values are in inch lbs. for size 400 and smaller, and in ft.lbs. for size 500 and larger.

## Dynamic Torque

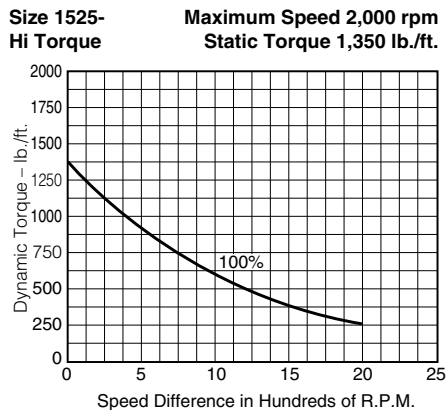
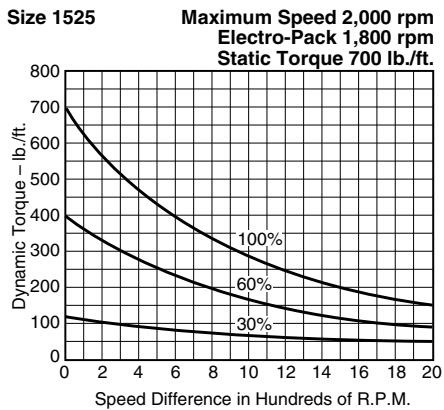
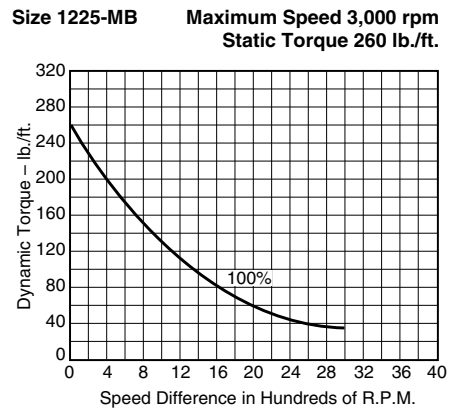
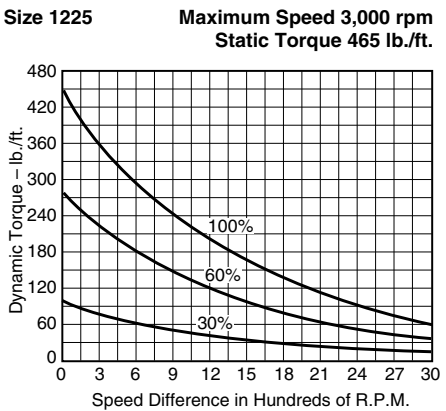
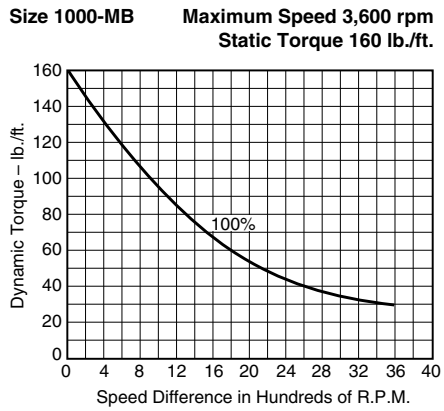
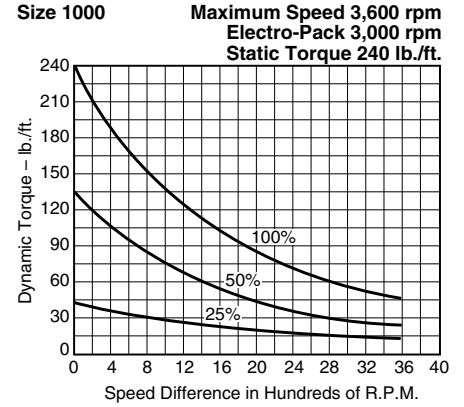
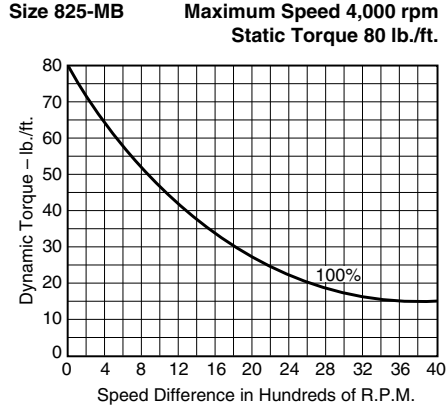
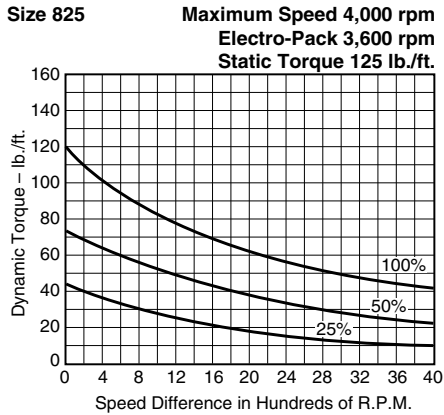

## Heat Dissipation

To accelerate any part of a machine from rest to a given velocity or decelerate from a given velocity to rest, energy must be given to or taken from the part. This energy, neglecting friction and windage losses, is equal to the energy possessed by the part when moving at the given velocity.

Kinetic energy in parts that rotate about an axis such as gears, pulleys, and rotors is:

$$E = 1.7 \times WR^2 \times \frac{N^2}{100}$$

Where:

N = RPM

E = Energy, ft.lb.

WR<sup>2</sup> = Inertia, lb.ft.<sup>2</sup>

On repetitive cycles, the energy per minute may be determined by multiplying the energy calculation by the cycle frequency F:

$$a. E/\text{min.} = 1.7 \times WR^2 \times \frac{N^2}{100} \times F$$

Where:

E/min. = Energy, ft.lb./min.

This becomes important when determining whether a given size clutch or brake is capable of dissipating the heat (energy) required to cycle a given load. To determine this, the heat dissipating capability of the clutch-brake must be calculated using the formula:

$$b. E/\text{min.} = \text{avg.}$$

$$\frac{t^1}{t^1 + t^2} \text{ @RPM}_1 \times \frac{E/\text{min.}}{t^1 + t^2} + \frac{t^2}{t^1 + t^2} \text{ @RPM}_2 \times \frac{E/\text{min.}}{t^1 + t^2}$$

Where:

t<sup>1</sup> = time(seconds) @ RPM<sub>1</sub>

t<sup>2</sup> = time (seconds) @ RPM<sub>2</sub>

RPM<sub>1</sub> = starting speed

RPM<sub>2</sub> = maximum speed

E/min. = energy rate from heat dissipation curves

The heat (energy) to be dissipated (per formula a. above) is then compared with the heat (energy) dissipating capacity (per formula b. above) of the clutch-brake to determine whether unit sizing is correct.

**Example:** A load of 5.353 lb.ft.<sup>2</sup> (includes couplings, bearings, etc.) is driven by a 15 HP, 700 RPM motor. Using an SF-1225 (bearing mounted, normal duty with armature in input side) and PB-1225 (normal duty, pin drive), determine whether this clutch-brake can be cycled 40 times per minute with an "on" time of one second without overheating.

1. Determine amount of heat which is dissipated at this cycle rate.

$$E = 1.7 \times WR^2 \times \frac{N^2}{100} \times F$$

Total WR<sup>2</sup>: 5.353 lb.ft.<sup>2</sup> (load inertia)  
 2.751 lb.ft.<sup>2</sup> (clutch inertia, ref. p. 239)  
 2.147 lb.ft.<sup>2</sup> (brake inertia, ref. p. 239)  
 Total = 10.251 lb.ft.<sup>2</sup>

$$E = 1.7 \times 10.251 \times \frac{700^2}{100} \times 40$$

$$E = 34,156 \text{ ft.lbs./min.}$$

2. Determine the heat dissipating capacity of this clutch-brake combination.

E/min. = avg.

$$\frac{t^1}{t^1 + t^2} \text{ @RPM}_1 \times \frac{E/\text{min.}}{t^1 + t^2} + \frac{t^2}{t^1 + t^2} \text{ @RPM}_2 \times \frac{E/\text{min.}}{t^1 + t^2}$$

Where:

t<sup>1</sup> = .5 second

t<sup>2</sup> = 1 second

RPM<sub>1</sub> = 0

RPM<sub>2</sub> = 700

E/min. @ RPM<sub>1</sub> = 20,000 ft. lbs./min.

E/min @ RPM<sub>2</sub> = 47,000 ft.lbs./min.

$$E/\text{min.} = \frac{.5}{1.5} \times 20,000 + \frac{1}{1.5} \times 47,000$$

E/min. = 38,000 ft.lbs.  
 avg.

Since the capacity (38,000 ft. lbs./min.) is greater than the heat to be dissipated (34,156 ft. lbs./min.), this clutch-brake can be operated continuously at 40 cycles/ min. under the stated load without overheating.

## Examples

Size 1225

Maximum Speed 3,000 rpm

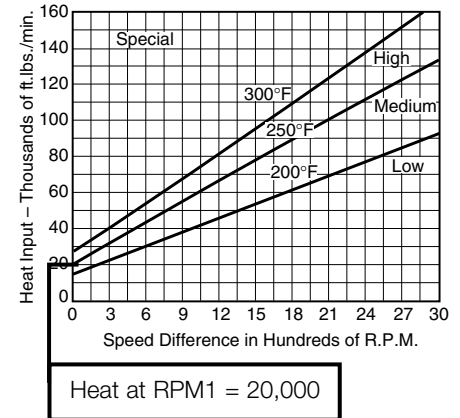

Size 1225

Maximum Speed 3,000 rpm

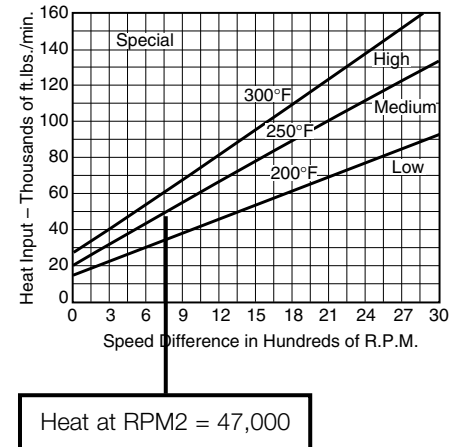

### Note:

Select a clutch or brake with heat dissipation requirements below the 250° line. For heat greater than 250° but less than 300°, special coils are required.

## Heat Dissipation

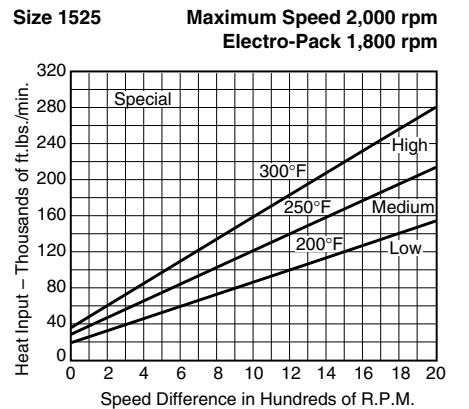
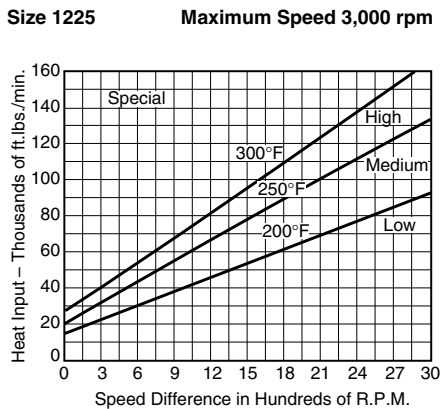
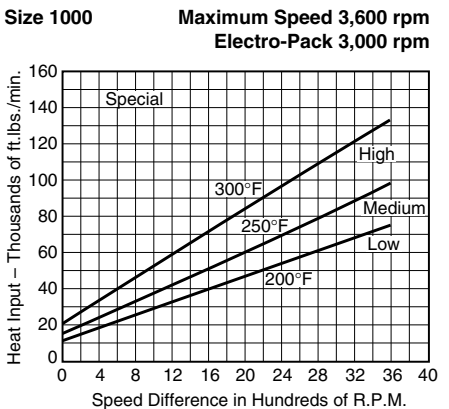
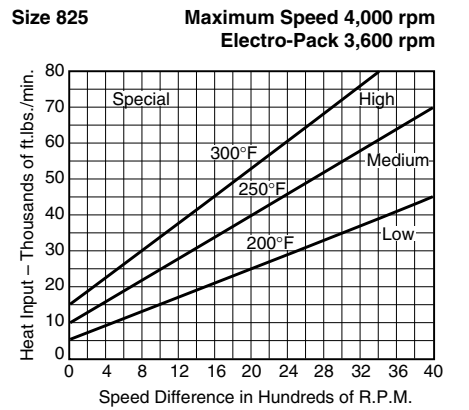
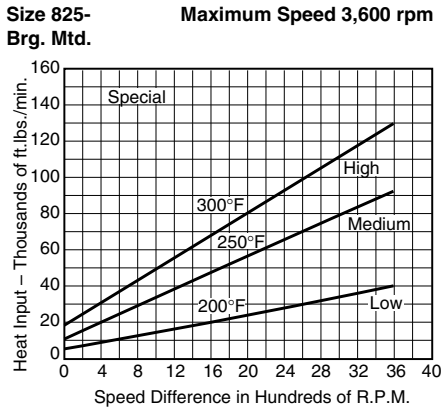
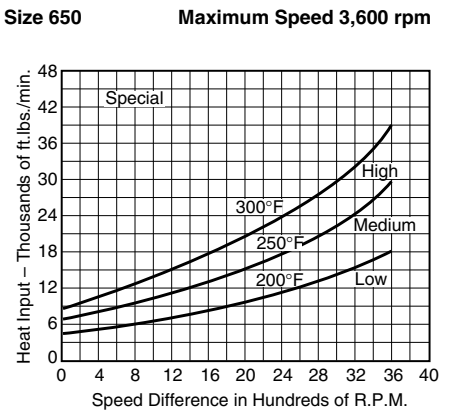
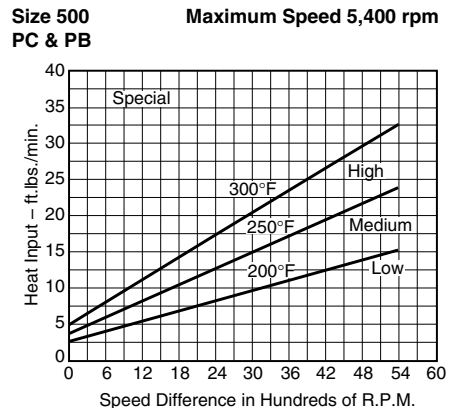
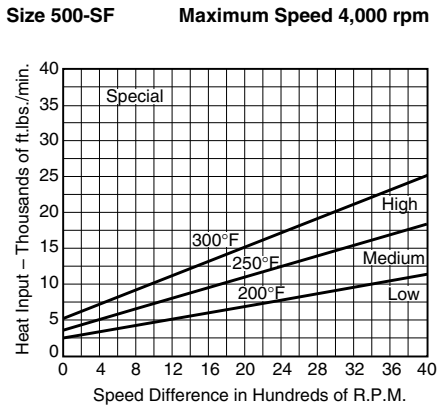
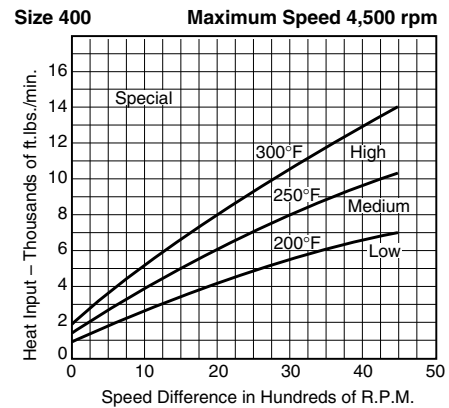
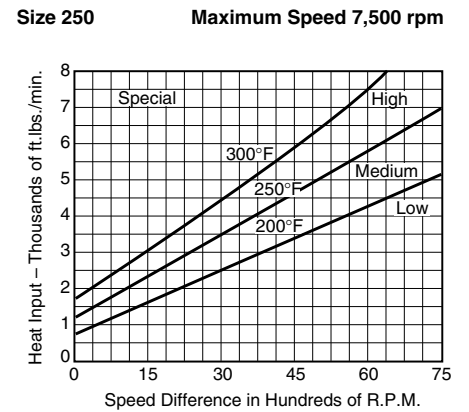
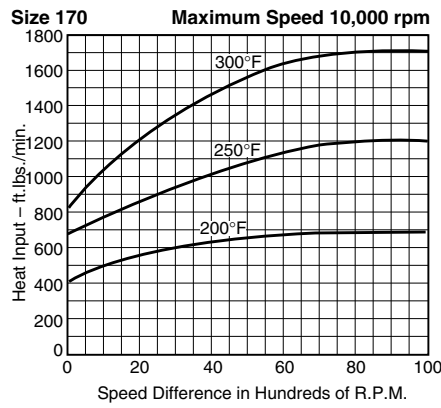
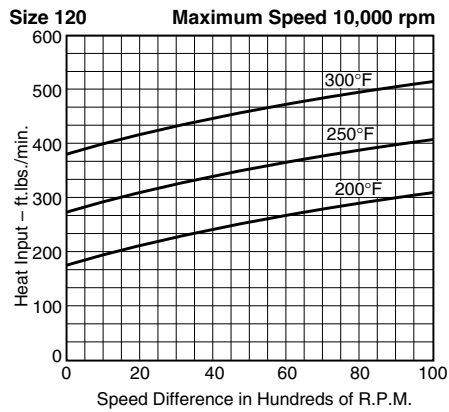

Moment of Inertia

Radii of Gyration for Rotating Bodies

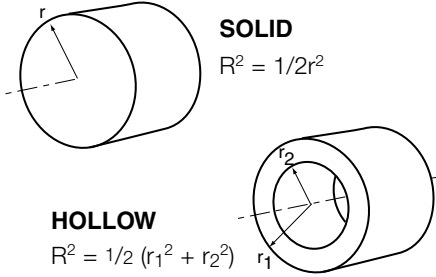

To simplify the calculation of the  $WR^2$  of more complex parts, these drawings show shapes most commonly encountered and the formula for calculating radius of gyration squared ( $R^2$ ). This multiplied by the weight of the part will give  $WR^2$ .

When calculating radius of gyration ( $R^2$ ) using the formula, be sure that all dimensions are converted to feet in order to get radius of gyration expressed in terms of pounds feet squared.

Inertia of Steel Shafting

*Per Inch of Length or Thickness*  
To determine  $WR^2$  of a given shaft or disc, multiply the  $WR^2$  given above by the length of shaft, or thickness of disc, in inches.

**NOTE:** For hollow shafts, subtract  $WR^2$  of the I.D. from the  $WR^2$  of the O.D. and multiply by length.

Per Inch of Length or Thickness

Dia. (In.)	$WR^2$ (lb.ft. <sup>2</sup> )	Dia. (In.)	$WR^2$ (lb.ft. <sup>2</sup> )	Dia. (In.)	$WR^2$ (lb.ft. <sup>2</sup> )
3/4	.00006	10-1/2	2.35	32	201.8
1	.0002	10-3/4	2.58	33	228.2
1-1/4	.0005	11	2.83	34	257.2
1-1/2	.001	11-1/4	3.09	35	288.8
1-3/4	.002	11-1/2	3.38	36	323.2
2	.003	11-3/4	3.68	37	360.7
2-1/4	.005	12	4.00	38	401.3
2-1/2	.008	12-1/4	4.35	39	445.3
2-3/4	.011	12-1/2	4.72	40	492.8
3	.016	12-3/4	5.11	41	543.9
3-1/2	0.029	13	5.58	42	598.8
3-3/4	0.038	13-1/4	5.96	43	658.1
4	0.049	13-1/2	6.42	44	721.4
4-1/4	0.063	13-3/4	6.91	45	789.3
4-1/2	0.079	14	7.42	46	861.8
5	0.120	14-1/4	7.97	47	939.3
5-1/2	0.177	14-1/2	8.54	48	1021.8
6	0.250	14-3/4	9.15	49	1109.6
6-1/4	0.296	15	9.75	50	1203.1
6-1/2	0.345	16	12.61	51	1302.2
6-3/4	0.402	17	16.07	52	1407.4
7	0.464	18	20.21	53	1518.8
7-1/4	0.535	19	25.08	54	1636.7
7-1/2	0.611	20	30.79	55	1761.4
7-3/4	0.699	21	37.43	56	1893.1
8	0.791	22	45.09	57	2031.9
8-1/4	0.895	23	53.87	58	2178.3
8-1/2	1.00	24	63.86	59	2332.5
8-3/4	1.13	25	75.19	60	2494.7
9	1.27	26	87.96	66	3652.5
9-1/4	1.41	27	102.30	72	5172
9-1/2	1.55	28	118.31	78	7125
9-3/4	1.75	29	136.14	84	9584
10	1.93	30	155.92	90	12629
10-1/4	2.13	31	177.77	96	16349
				102	20836



**Weights and Inertia**

**NOTE:** The "Weight" column gives the "average" weight per item  
The "Inertia" column gives the inertia of "rotating" components.

**SF Series (Stationary Field Clutches)**

Unit Size	SF-120, B.M.		SF-170, B.M.		SF-250, B.M.		SF-400, B.M.	
	Wt. (lbs.)	Inertia (lbs.in. <sup>2</sup> )	Wt. (lbs.)	Inertia (lbs.in. <sup>2</sup> )	Wt. (lbs.)	Inertia (lbs.in. <sup>2</sup> )	Wt. (lbs.)	Inertia (lbs.in. <sup>2</sup> )
Field & Rotor Assembly .....	.113	.00831	.356	.036	1.00	.253	3.59	2.157
Field .....	.053	.....	.218	.....	.651	.....	2.13	.....
Rotor .....	.049	.00717	.138	.036	.348	.253	1.459	2.157
Set Collar .....	.011	.00114	.....	.....	.029	.004	.....	.....
Armature .....	.018	.00378	.031	.014	.234	.255	.670	1.56
Armature Hub .....	.020	.00413	.071	.00518	.557	.202	.540	.213
Antibacklash Armature .....	.....	.00467	.....	.025	.....	.293	.....	1.751
Unit Size	SF-120, F.M.		SF-170, F.M.		SF-250, F.M.		SF-400, F.M.	
	Wt. (lbs.)	Inertia (lbs.in. <sup>2</sup> )	Wt. (lbs.)	Inertia (lbs.in. <sup>2</sup> )	Wt. (lbs.)	Inertia (lbs.in. <sup>2</sup> )	Wt. (lbs.)	Inertia (lbs.in. <sup>2</sup> )
Field .....	.060	.....	.250	.....	.678	.....	2.433	.....
Rotor .....	.049	.00717	.127	.033	.367	.267	1.386	2.152
Armature .....	.018	.00378	.031	.014	.234	.255	.670	1.56
Armature Hub .....	.020	.00413	.071	.00518	.111	.030	.540	.213
Antibacklash Armature .....	.....	.00467	.....	.025	.....	.293	.....	1.751
Unit Size	SF-500, B.M.		SF-650, B.M.		SF-650, F.M.			
	Wt. (lbs.)	Inertia (lbs.ft. <sup>2</sup> )	Wt. (lbs.)	Inertia (lbs.ft. <sup>2</sup> )	Wt. (lbs.)	Inertia (lbs.ft. <sup>2</sup> )	Wt. (lbs.)	Inertia (lbs.ft. <sup>2</sup> )
Field & Rotor Assembly .....			5.947	.036	9.8	.21	.....	.....
Field .....			3.618	.....	4.4	.....	4.4	.....
Rotor .....			2.329	.036	2.3	.20	2.3	.20
Rotor Hub .....			.....	.....	1.8	.01	1.8	.01
Armature & Pins .....			1.20	.033	1.8	.08	1.8	.08
Unit Size	SF-825, F.M.		SF-1000, F.M.		SF-825, F.M.		SF-1000, F.M.	
	Wt. (lbs.)	Inertia (lbs.ft. <sup>2</sup> )	Wt. (lbs.)	Inertia (lbs.ft. <sup>2</sup> )	Wt. (lbs.)	Inertia (lbs.ft. <sup>2</sup> )	Wt. (lbs.)	Inertia (lbs.ft. <sup>2</sup> )
Field & Rotor Assembly .....					8.750	.....	11.125	.....
Field .....					5.148	.381	7.880	.894
Rotor .....					.311	.003	1.089	.027
Rotor Hub .....					4.783	.323	6.0	.624
Armature & Pins .....					.315	.0015	.810	.088
Bushing: Max. Bore to .....					.583	.0018	1.685	.011
Min. Bore .....								
Unit Size	SF-825, B.M.		SF-1000, B.M.		SF-1225, B.M.		SF-1525, B.M.	
	Wt. (lbs.)	Inertia (lbs.ft. <sup>2</sup> )	Wt. (lbs.)	Inertia (lbs.ft. <sup>2</sup> )	Wt. (lbs.)	Inertia (lbs.ft. <sup>2</sup> )	Wt. (lbs.)	Inertia (lbs.ft. <sup>2</sup> )
Field & Rotor Assembly .....	15.552	.756	26.905	1.004	49.455	2.75	73.316	5.989
Field .....	8.994	.....	11.125	.....	21.250	.....	30.750	.....
Field Hub & Brg. ....	.....	.....	3.400	.....	5.800	.....	12.200	.....
Rotor .....	6.558	.756	7.880	.894	14.005	2.421	18.266	5.139
Rotor Hub .....	.....	.....	4.500	.110	8.400	.330	12.100	.850
Armature & Pins .....	4.738	.373	6.0	.624	10.84	1.7	15.362	3.962
Bushing: Max. Bore to .....	.301	.002	.810	.008	1.553	.022	3.234	.071
Min. Bore .....	.762	.003	1.685	.011	3.575	0.31	6.345	.099
Unit Size	SF-1225, F.M.		SF-1525, F.M.		SF-1525, H.T.			
	Wt. (lbs.)	Inertia (lbs.ft. <sup>2</sup> )	Wt. (lbs.)	Inertia (lbs.ft. <sup>2</sup> )	Wt. (lbs.)	Inertia (lbs.ft. <sup>2</sup> )	Wt. (lbs.)	Inertia (lbs.ft. <sup>2</sup> )
Field .....			21.250	.....	30.750	.....	29.500	.....
Rotor .....			14.005	2.421	18.266	5.139	20.493	5.866
Rotor Hub .....			2.181	.081	4.963	.323	4.963	.323
Bushing: Max. Bore to .....			1.553	.022	3.234	.071	3.234	.071
Unit Size .....			3.575	.031	6.345	.099	6.345	.099
Armature & Splined Adapter .....			.....	.....	.....	.....	22.528	4.498
Armature & Pins .....			10.84	1.7	15.362	3.962	.....	.....
Splined Hub .....			.....	.....	.....	.....	2.792	.069

**Weights and Inertia**

**SFC Series (Stationary Field Clutch Couplings)**

**NOTE:** The "Weight" column gives the "average" weight per item. The "Inertia" column gives the inertia of "rotating" components.

Unit Size	SFC-120, B.M.		SFC-170, B.M.		SFC-250, B.M.		SFC-400, B.M.			
	Wt. (lbs.)	Inertia (lbs.in. <sup>2</sup> )	Wt. (lbs.)	Inertia (lbs.in. <sup>2</sup> )	Wt. (lbs.)	Inertia (lbs.in. <sup>2</sup> )	Wt. (lbs.)	Inertia (lbs.in. <sup>2</sup> )		
Field & Rotor Assembly .....	.113	.00831	.356	.036	1.00	.253	3.59	2.157		
Field .....	.053	.....	.218	.....	.651	.....	2.13	.....		
Rotor .....	.049	.00717	.138	.036	.348	.253	1.459	2.157		
Set Collar .....	.011	.00114	.....	.....	.029	.004	.....	.....		
Armature .....	.018	.00378	.031	.014	.234	.255	.670	1.56		
Armature Hub .....	.019	.000407	.032	.00223	.111	.030	.249	.091		
Antibacklash Armature .....	.....	.00456	.....	.024	.....	.293	.....	1.751		
Unit Size	SFC-120, F.M.		SFC-170, F.M.		SFC-250, F.M.		SFC-400, F.M.			
	Wt. (lbs.)	Inertia (lbs.in. <sup>2</sup> )	Wt. (lbs.)	Inertia (lbs.in. <sup>2</sup> )	Wt. (lbs.)	Inertia (lbs.in. <sup>2</sup> )	Wt. (lbs.)	Inertia (lbs.in. <sup>2</sup> )		
Field .....	.060	.....	.250	.....	.678	.....	2.433	.....		
Rotor .....	.049	.00717	.127	.033	.367	.267	1.386	2.152		
Armature .....	.018	.00378	.031	.014	.234	.255	.670	1.56		
Armature Hub .....	.019	.000407	.032	.00223	.111	.030	.249	.091		
Antibacklash Armature .....	.....	.00456	.....	.024	.....	.293	.....	1.751		
Unit Size					SFC-500, N.D.		SFC-500, H.D.			
					Wt. (lbs.)	Inertia (lbs.ft. <sup>2</sup> )	Wt. (lbs.)	Inertia (lbs.ft. <sup>2</sup> )		
Field & Rotor Assembly .....					5.947	.036	5.947	.036		
Field .....					3.618	.....	3.618	.....		
Rotor .....					2.329	.036	2.329	.036		
Armature & Pins .....					1.20	.033	.....	.....		
Armature .....					.....	.....	1.192	.029		
Armature Hub .....					.941	.018	.161	.0007		
Bushing: Max. Bore to .....					.436	.002	.....	.....		
Min. Bore .....					.842	.003	.....	.....		
Unit Size					SFC-650, B.M.		SFC-650, F.M.			
					Wt. (lbs.)	Inertia (lbs.ft. <sup>2</sup> )	Wt. (lbs.)	Inertia (lbs.ft. <sup>2</sup> )		
Field & Rotor Assembly .....					9.8	.21	.....	.....		
Field .....					4.4	.....	4.4	.....		
Rotor .....					2.3	.20	2.3	.20		
Rotor Hub .....					1.8	.01	1.8	.01		
Armature & Pins .....					1.8	.08	1.8	.08		
Armature Hub .....					1.3	.02	1.3	.02		
Unit Size	SFC-825, B.M.		SFC-1000, B.M.		SFC-1225, B.M.		SFC-1525, B.M.			
	Wt. (lbs.)	Inertia (lbs.ft. <sup>2</sup> )	Wt. (lbs.)	Inertia (lbs.ft. <sup>2</sup> )	Wt. (lbs.)	Inertia (lbs.ft. <sup>2</sup> )	Wt. (lbs.)	Inertia (lbs.ft. <sup>2</sup> )		
Field & Rotor Assembly .....	15.552	.756	26.905	1.004	49.455	2.75	73.316	5.989		
Field .....	8.994	.....	11.125	.....	21.250	.....	30.750	.....		
Field Hub & Brg. ....	.....	.....	3.400	.....	5.800	.....	12.200	.....		
Rotor .....	6.558	.756	7.880	.894	14.005	2.421	18.266	5.139		
Rotor Hub .....	.....	.....	4.500	.110	8.400	.330	12.100	.850		
Bushing - Rotor Hub: Max. Bore to .....	.600	.004	.810	.008	1.533	.022	3.234	.071		
Min. Bore .....	1.276	.005	1.685	.010	3.575	0.31	6.345	.099		
Armature & Splined Adapter .....	5.263	.326	6.84	.667	13.408	1.817	22.528	4.498		
Splined Hub .....	.834	.006	3.547	.077	3.582	.077	3.582	.077		
Bushing - Splined Hub: Max. Bore to .....	.301	.0026	2.064	.033	2.064	.033	2.064	.033		
Min. Bore .....	.762	.0039	4.171	.048	4.171	.048	4.171	.048		
Unit Size	SFC-825, F.M.		SFC-1000, F.M.		SFC-1225, F.M.		SFC-1525, F.M.		SFC-1525, H.T.	
	Wt. (lbs.)	Inertia (lbs.ft. <sup>2</sup> )	Wt. (lbs.)	Inertia (lbs.ft. <sup>2</sup> )	Wt. (lbs.)	Inertia (lbs.ft. <sup>2</sup> )	Wt. (lbs.)	Inertia (lbs.ft. <sup>2</sup> )	Wt. (lbs.)	Inertia (lbs.ft. <sup>2</sup> )
Field .....	8.750	.....	11.125	.....	21.250	.....	30.750	.....	29.500	.....
Rotor .....	5.148	.381	7.880	.894	14.005	2.421	18.266	5.139	20.493	5.866
Rotor Hub .....	.311	.003	1.089	.027	2.181	.081	4.963	.323	4.963	.323
Bushing-Rotor Hub: Max. Bore to .....	.315	.0015	.810	.008	1.553	.022	3.234	.071	3.234	.071
Min. Bore .....	.583	.0018	1.685	.011	3.575	.031	6.345	.099	6.345	.099
Armature & Splined Adapter .....	5.263	.326	6.84	.667	13.408	1.817	22.528	4.498	22.528	4.498
Splined Hub .....	.834	.006	3.547	.077	3.582	.077	3.582	.077	3.582	.077
Bushing-Splined Hub: Max. Bore to .....	.301	.0026	2.064	.033	2.064	.033	2.064	.033	2.064	.033
Min. Bore .....	.762	.0039	4.171	.048	4.171	.048	4.171	.048	4.171	.048

**Weights and Inertia**

**NOTE:** The "Weight" column gives the "average" weight per item.  
The "Inertia" column gives the inertia of "rotating" components.

**PC Series (Primary Clutches)**

Unit Size							PC-500	
							Wt. (lbs.)	Inertia (lbs.ft. <sup>2</sup> )
Magnet .....							2.800	.074
Magnet Hub Assembly .....							1.224	.031
Armature & Pins .....							1.20	.033
Armature .....							.....	.....
Armature Hub .....							.....	.....
Bushing: Max. Bore to .....							.....	.....
Min. Bore .....							.....	.....
Unit Size	PC-825		PC-1000		PC-1225		PC-1525	
	Wt. (lbs.)	Inertia (lbs.ft. <sup>2</sup> )	Wt. (lbs.)	Inertia (lbs.ft. <sup>2</sup> )	Wt. (lbs.)	Inertia (lbs.ft. <sup>2</sup> )	Wt. (lbs.)	Inertia (lbs.ft. <sup>2</sup> )
Magnet .....	7.178	.571	10.549	1.297	18.557	3.245	27.817	7.416
Magnet Hub Assembly .....	4.362	.257	5.702	.332	7.252	.461	9.350	.680
Armature & Pins .....	4.783	.323	6.0	.629	10.84	1.7	15.362	3.925
Bushing: Max. Bore to .....	.600	.004	1.553	.022	4.055	.085	4.055	.085
Min. Bore .....	1.276	.005	3.575	.031	9.141	.133	9.141	.133

**PCC Series (Primary Clutch Couplings)**

Unit Size					PCC-500, N.D.		PCC-500, H.D.	
					Wt. (lbs.)	Inertia (lbs.ft. <sup>2</sup> )	Wt. (lbs.)	Inertia (lbs.ft. <sup>2</sup> )
Magnet .....					2.800	.074	2.800	.074
Magnet Hub Assembly .....					1.224	.031	1.224	.031
Armature & Pins .....					1.20	.033	.....	.....
Armature .....					.....	.....	1.192	.029
Armature Hub .....					.941	.018	.161	.0007
Bushing: Max. Bore to .....					.436	.002	.....	.....
Min. Bore .....					.842	.003	.....	.....
Unit Size	PCC-825		PCC-1000		PCC-1225		PCC-1525	
	Wt. (lbs.)	Inertia (lbs.ft. <sup>2</sup> )	Wt. (lbs.)	Inertia (lbs.ft. <sup>2</sup> )	Wt. (lbs.)	Inertia (lbs.ft. <sup>2</sup> )	Wt. (lbs.)	Inertia (lbs.ft. <sup>2</sup> )
Magnet .....	7.780	.571	10.549	1.297	18.557	3.245	27.817	7.416
Magnet Hub Assembly .....	4.362	.257	5.702	.332	7.252	.461	9.350	.680
Armature & Splined Adapter .....	5.263	.326	6.84	.667	13.408	1.817	22.528	4.498
Splined Hub .....	.834	.006	3.547	.077	3.582	.077	3.582	.077
Bushing - Magnet Hub								
Max. Bore to.....	.600	.004	1.533	.022	4.055	.085	4.055	.085
Min. Bore .....	1.276	.005	3.575	.031	9.141	.133	9.141	.133
Bushing - Splined Hub								
Max. Bore to.....	.301	.002	2.064	.033	2.064	.033	2.064	.033
Min. Bore .....	.762	.003	4.171	.048	4.171	.048	4.171	.048

## Weights and Inertia

### PB Series (Primary Brakes)

**NOTE:** The "Weight" column gives the "average" weight per item. The "Inertia" column gives the inertia of "rotating" components.

Unit Size	PB-120		PB-170		PB-250		PB-400	
	Wt. (lbs.)	Inertia (lbs.in. <sup>2</sup> )	Wt. (lbs.)	Inertia (lbs.in. <sup>2</sup> )	Wt. (lbs.)	Inertia (lbs.in. <sup>2</sup> )	Wt. (lbs.)	Inertia (lbs.in. <sup>2</sup> )
Magnet .....	.090	.....	.263	.....	.846	.....	3.034	.....
Armature .....	.018	.00378	.031	.014	.234	.255	.670	1.56
Armature Hub .....	.019	.000407	.032	.00223	.111	.030	.249	.091
Antibacklash Armature .....	.....	.00456	.....	.024	.....	.293	.....	1.751
Unit Size	PB-500, N.D.		PB-500, H.D.		PB-650			
	Wt. (lbs.)	Inertia (lbs.ft. <sup>2</sup> )	Wt. (lbs.)	Inertia (lbs.ft. <sup>2</sup> )	Wt. (lbs.)	Inertia (lbs.ft. <sup>2</sup> )	Wt. (lbs.)	Inertia (lbs.ft. <sup>2</sup> )
Magnet .....			2.800	.....	2.800	.....	4.5	.....
Armature & Pins .....			1.20	.033				
Armature .....			.....	.....	1.192	.029	1.8	.08
Armature Hub .....			.941	.018	.161	.0007	1.3	.02
Bushing: Max. Bore to .....			.436	.002	.....	.....	.....	.....
Min. Bore .....			.842	.003	.....	.....	.....	.....
Unit Size	PB-825, N.D.		PB-1000, N.D.		PB-1225, N.D.		PB-1525, N.D.	
	Wt. (lbs.)	Inertia (lbs.ft. <sup>2</sup> )	Wt. (lbs.)	Inertia (lbs.ft. <sup>2</sup> )	Wt. (lbs.)	Inertia (lbs.ft. <sup>2</sup> )	Wt. (lbs.)	Inertia (lbs.ft. <sup>2</sup> )
Magnet .....	7.780	.....	10.549	.....	18.557	.....	27.817	.....
Armature .....	4.783	.323	6.0	.629	10.227	1.667	15.362	3.925
Armature Hub .....	1.857	.043	3.860	.164	6.716	.380	8.127	.602
Bushing: Max. Bore to .....	.600	.004	1.553	.022	4.055	.085	4.055	.085
Min. Bore .....	1.276	.005	3.575	.031	9.141	.133	9.141	.133
Unit Size	PB-825, H.D.		PB-1000, H.D.		PB-1225, H.D.		PB-1525, H.D.	
	Wt. (lbs.)	Inertia (lbs.ft. <sup>2</sup> )	Wt. (lbs.)	Inertia (lbs.ft. <sup>2</sup> )	Wt. (lbs.)	Inertia (lbs.ft. <sup>2</sup> )	Wt. (lbs.)	Inertia (lbs.ft. <sup>2</sup> )
Magnet .....	7.780	.....	10.549	.....	18.557	.....	27.817	.....
Armature & Splined Adapter .....	5.263	.326	6.84	.667	13.317	1.737	22.528	4.498
Splined Hub .....	.834	.006	3.547	.077	3.582	.077	3.582	.077
Bushing - Splined Hub								
Max. Bore to .....	.301	.002	2.064	.033	2.064	.033	2.064	.033
Min. Bore .....	.762	.003	4.171	.048	4.171	.048	4.171	.048

### MB Series (Motor Brakes)

Unit Size	MB-825		MB-1000		MB-1225	
	Wt. (lbs.)	Inertia (lbs.ft. <sup>2</sup> )	Wt. (lbs.)	Inertia (lbs.ft. <sup>2</sup> )	Wt. (lbs.)	Inertia (lbs.ft. <sup>2</sup> )
Magnet .....	7.780	.....	10.549	.....	18.557	.....
Armature & Pins .....	4.783	.323	6.0	.629	10.84	1.7
Armature Hub .....	1.857	.043	3.860	.164	6.716	.380
Bushing: Max. Bore to .....	.600	.004	1.533	.022	1.553	.022
Min. Bore .....	1.276	.005	3.575	.031	3.575	.031
Cover .....	3.687	.....	4.875	.....	6.0	.....
Adapter .....	3.5	.....	5.5	.....	7.0	.....

### PCB Series (Primary Clutch/Brake Comination)

Unit Size	PCB-825		PCB-1000		PCB-1225	
	Wt. (lbs.)	Inertia (lbs.ft. <sup>2</sup> )	Wt. (lbs.)	Inertia (lbs.ft. <sup>2</sup> )	Wt. (lbs.)	Inertia (lbs.ft. <sup>2</sup> )
Magnet - Brake .....	7.780	.....	10.549	.....	18.557	.....
Magnet - Clutch .....	7.780	.571	10.549	1.297	18.557	3.245
Magnet Hub Assembly .....	4.362	.257	5.702	.332	7.252	.461
Bushing: Max. Bore to .....	.600	.004	1.553	.022	4.055	.085
Min. Bore .....	1.276	.005	3.575	.031	9.141	.133
Armature & Pins .....	4.783	.323	6.0	.629	10.84	1.7
Unit Size	PCB-1225/1000		PCB-1525/1225			
	Wt. (lbs.)	Inertia (lbs.ft. <sup>2</sup> )	Wt. (lbs.)	Inertia (lbs.ft. <sup>2</sup> )	Wt. (lbs.)	Inertia (lbs.ft. <sup>2</sup> )
Magnet - Brake .....			10.549	.....	18.557	.....
Magnet - Clutch .....			18.557	3.245	27.817	7.416
Magnet Hub Assembly .....			5.702	.332	9.350	.680
Bushing - Magnet Hub: Max. Bore to ..			1.553	.022	4.055	.085
Min. Bore .....			3.575	.031	9.141	.133
Armature & Pins - Brake .....			6.0	.629	10.227	1.667
Armature & Pins - Clutch .....			10.227	1.667	15.362	3.925

**Weights and Inertia**

**NOTE:** The "Weight" column gives the "average" weight per item  
The "Inertia" column gives the inertia of "rotating" components.

**SFPBC Series (Stationary Field Clutch/Brake Couplings)**

Unit Size			SFPBC-500, N.D.		SFPBC-650, N.D.	
			Wt. (lbs.)	Inertia (lbs.ft. <sup>2</sup> )	Wt. (lbs.)	Inertia (lbs.ft. <sup>2</sup> )
Field & Rotor Assembly .....			5.947	.036	9.8	.21
Field .....			3.618	.....	4.4	.....
Rotor .....			2.329	.036	2.3	.20
Rotor Hub .....			.....	.....	1.8	.01
Magnet .....			2.800	.....	4.5	.....
Magnet Hub Assembly .....			.....	.....	.....	.....
Armature .....			.....	.....	.....	.....
Armature & Pins .....			1.20	.033	1.8	.08
Armature Hub .....			.941	.018	1.3	.02
Bushing: Max. Bore to .....			.436	.002	.....	.....
Min. Bore .....			.842	.003	.....	.....

**PCBC Series (Primary Clutch/Brake Couplings)**

Unit Size			PCBC-500, N.D.		PCBC-500, H.D.			
			Wt. (lbs.)	Inertia (lbs.ft. <sup>2</sup> )	Wt. (lbs.)	Inertia (lbs.ft. <sup>2</sup> )		
Field & Rotor Assembly .....			.....	.....	.....	.....		
Field .....			.....	.....	.....	.....		
Rotor .....			.....	.....	.....	.....		
Rotor Hub .....			.....	.....	.....	.....		
Magnet .....			2.800	.074	2.800	.074		
Magnet Hub Assembly .....			1.224	.031	1.224	.031		
Armature .....			.....	.....	1.192	.029		
Armature & Pins .....			1.20	.033	.....	.....		
Armature Hub .....			.941	.018	.....	.....		
Bushing: Max. Bore to .....			.941	.002	.436	.002		
Min. Bore .....			.842	.003	.842	.003		
Splined Hub: 5300-541-006 .....			.....	.....	1.914	.0073		
5300-541-007 .....			.....	.....	1.800	.0071		
5300-541-008 .....			.....	.....	1.735	.0071		
5300-541-009 .....			.....	.....	1.667	.0069		
5300-541-010 .....			.....	.....	1.518	.0067		
5300-541-011 .....			.....	.....	1.351	.0063		
Unit Size			PCBC-825		PCBC-1000		PCBC-1225	
			Wt. (lbs.)	Inertia (lbs.ft. <sup>2</sup> )	Wt. (lbs.)	Inertia (lbs.ft. <sup>2</sup> )	Wt. (lbs.)	Inertia (lbs.ft. <sup>2</sup> )
Magnet - Brake .....			7.780	.....	10.549	.....	18.557	.....
Magnet - Clutch .....			7.780	.571	10.549	1.297	18.557	3.495
Magnet Hub Assembly .....			4.362	.257	5.702	.332	7.252	.461
Bushing - Magnet Hub: Max. Bore to ..			.600	.004	1.553	.022	4.055	.085
Min. Bore.....			1.276	.005	3.575	.031	9.141	.133
Armature & Splined Adapter - Clutch ..			4.49	.281	6.942	.625	13.317	1.671
Armature & Pins - Brake .....			5.263	.326	6.84	.667	13.408	1.817
Splined Hub .....			4.783	.323	6.0	.629	10.84	1.7
Bushing - Splined Hub: Max. Bore to ..			.301	.002	2.064	.033	2.064	.033
Min. Bore.....			.762	.003	4.171	.048	4.171	.048
Unit Size			PCBC-1225/1000		PCBC-1525/1225			
			Wt. (lbs.)	Inertia (lbs.ft. <sup>2</sup> )	Wt. (lbs.)	Inertia (lbs.ft. <sup>2</sup> )		
Magnet - Brake .....			10.549	.....	18.557	.....		
Magnet - Clutch .....			18.557	3.495	27.817	7.416		
Magnet Hub Assembly .....			5.702	.332	9.350	.680		
Bushing - Magnet Hub: Max. Bore to ..			1.553	.022	4.055	.085		
Min. Bore.....			3.575	.031	9.141	.133		
Armature & Splined Adapter - Clutch ..			13.523	1.737	22.528	4.498		
Armature - Brake .....			6.0	.629	15.362	3.925		
Splined Hub .....			3.582	.077	3.582	.077		
Bushing - Splined Hub: Max. Bore to ..			2.064	.033	2.064	.033		
Min. Bore.....			4.171	.048	4.171	.048		

## Rotational Speed

### Rotational Speed

Rotational speed of a clutch or brake is an important consideration when selecting a unit for a particular application. Numerous factors must be considered, such as the maximum rated speed of the clutch/brake unit, the dynamic torque required, the heat dissipation needed, the effect of speed on wear rate, and torque stability at very low speeds. Each of these issues are separate, and sometimes interrelated, but always important in selecting the right product for an application.

### Maximum RPM Rating

The most important rotational speed consideration is the maximum rated RPM capability of a unit. DO NOT exceed this rating. Exceeding the maximum RPM of a unit may cause personal injury and/or machine damage. Maximum rated speeds are based on the structural integrity of the rotating components and associated shaft and bearing capabilities. If the RPM rating is exceeded, structural failure may occur, or the unit may experience premature bearing failure and/or premature friction material wear out.

### Dynamic Torque

When determining the correct size clutch/brake for an application, dynamic torque at the highest slip speed is often the determining factor. As you can see by reviewing the dynamic torque curves for different units as shown starting on page 234, dynamic clutch/brake torque usually decreases with higher speeds. As slip RPM increases, the coefficient of friction of a unit decreases, causing a decrease in dynamic torque availability. Be careful to consider this when selecting the appropriate unit size needed.

Warner Electric has devised a simple to use selection chart based on motor HP and unit RPM. See pages 8 and 9.

### Heat Dissipation

Heat dissipation is inversely related to dynamic torque. As RPM increases, the heat dissipation ability of a unit increases. When an armature is rotating, the heat dissipation rate is proportional to the aerodynamic fan effect of the rotating armature. The faster the armature rotates, the greater the heat dissipation. This is illustrated with a typical catalog curve as shown in Figure 1. It's interesting to note that, at zero RPM, the unit still has some heat dissipation capability. This is due to convection and radiation, but is usually not an important consideration.

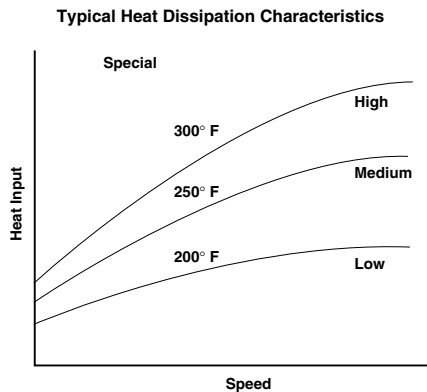

Figure 1

### Wear Rate

The wear rate of friction surfaces is dependent on the clamping pressure of the mating surfaces as well as the surface velocity between the wearing surfaces. Many variables are involved in predicting wear life, of which RPM is probably the most influential. Typically, the wear rate will increase directly with the rubbing velocity distance. Another way of stating this is the higher the relative engagement speeds of two rotating parts, the longer they are allowed to slip against each other and the faster the wear rate.

### Low Speed Operation

The effect of low speed usage should also be considered in applications. Performance of clutch/brake units at less than 100 RPM may be very different than at higher RPM. This is due to "burnish" characteristics of friction surfaces.

### Wear In

"Burnish" is the wear in, or mating of two surfaces. When new, these surfaces have manufacturing features which include roughness and waviness. When these surfaces come into initial contact, only the high spots actually meet. See Figure 2. This results in only a small surface area in contact, while the non-contact surface area is "air." The result is low torque. As the mating surfaces continue to engage and slip against each other, the high spots are worn down and more surface area is in contact, thus increasing torque capability. This wear in period, or burnish, typically occurs in the first few hundred cycles of a clutch/brake's life. Faster slip speeds and higher loads mean fewer cycles needed to complete the burnish process. For applications where the speed is less than 100 RPM, the required application torque should be doubled to compensate for the low speed "burnish" that the unit experiences. A low speed burnish will require many cycles before full

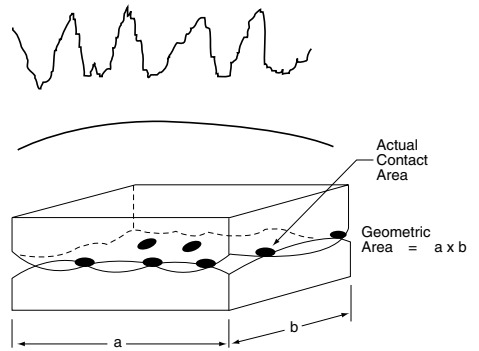

Figure 2 Unburnished Contact Areas

torque and stability are achieved. For example, if an application is determined to need 20 ft.lbs. of static torque, an SF-400 clutch could be selected. But, if the application is only 100 RPM or less, then an SF-500 unit should be the choice to compensate for the low RPM usage, as indicated on the selection chart found on page 234.

Careful consideration of rotating speeds will help the selection process of an application. Follow these guidelines and the proper clutch/brake selected will provide troublefree operation.

**Clutch Field Restraining Devices**

Many Warner Electric clutch assemblies have a bearing mounted stationery field. By design the bearing maintains its proper position between the field and rotor making it easy for the customer to mount the field-rotor assembly. However, the bearing has a slight drag which tends to make the field rotate if not restrained. And, since the field has lead wires attached, it must be restrained to prevent rotation and pulling of these wires. To counteract this rotational force, the field has a "torque tab" to which the customer must attach an appropriate anti-rotational restraint.

A few hints regarding proper torque tab restraints are in order. First and foremost, it is important to recognize that the force to be overcome is very small and the tab should not be restrained in any manner which will preload the bearing. For example, if the clutch is mounted with the back of the field adjacent to a rigid machine member the customer should not attach a capscrew tightly between the tab and the machine member. This may pull the tab back against the rigid member as shown in Figure 1 and preload the bearing. The recommended methods are illustrated in Figures 2, 3, and 4. The method selected is primarily a matter of customer preference or convenience.

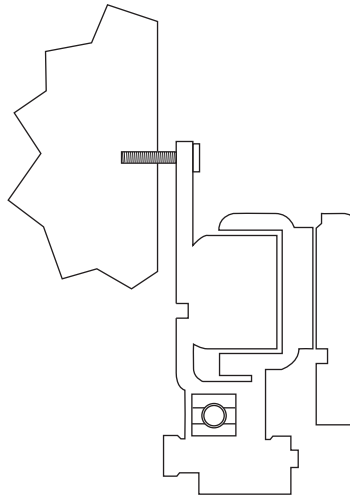

**Figure 1**  
Rigid member

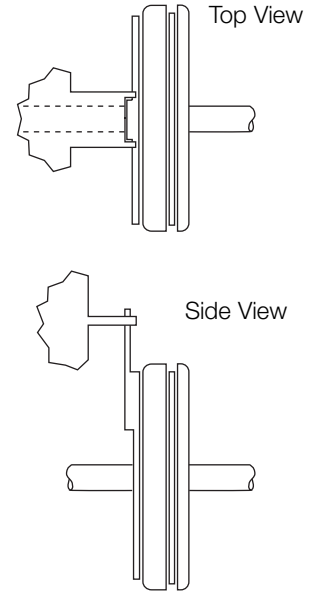

**Figure 2**  
Rigid Member with Slot  
Straddling Tab  
(Preferred)

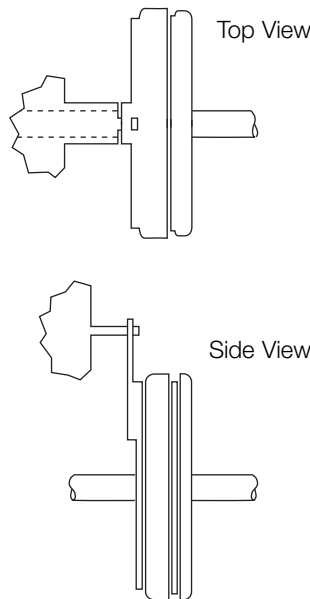

**Figure 3**  
Pin in Hole  
Loosely  
(Preferred)

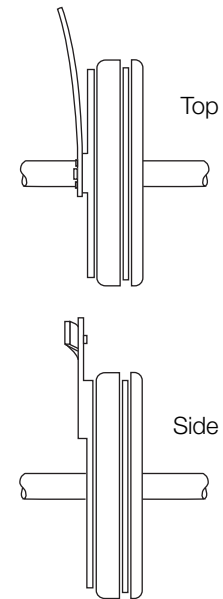

**Figure 4**  
Flexible Strap  
(Preferred)

## UL Testing

Before beginning any discussion of Warner Electric's program related to UL, it is important to clearly understand what lies behind the UL listing mark.

Underwriters' Laboratories Inc., (UL) is an independent testing organization. UL cooperates in the development of the (NEC) National Electrical Code published by the National Fire Protection Association, and with organizations such as (NEMA) National Electrical Manufacturers' Association and the (JIC) Joint Industry Conference in establishing standards. UL, however, is entirely independent. Contrary to what many people think, UL does not "approve" or "disapprove" electrical products. So, although the term "UL approved" is commonly used, it is incorrect. Instead, UL tests and evaluates a product according to applicable UL standards and then reports the results to the manufacturer. Because UL tests products for all foreseeable electrical hazards to life and property, safety conscious end-product users equate the UL symbol with product safety.

### Services

UL provides four testing services:

certification, classification, listing, and recognition. Electrical products fit into one of these categories according to their intended use.

1. The "certification" service evaluates only field installed systems at specific locations, or specific quantities of certain products where it is impractical to apply the Listing Mark or Classification Marking.
2. The "classification" service evaluates products only for specific hazards or under specific conditions.
3. The "listing" service tests end-products for all reasonably foreseeable hazards to life and property. UL defines end-products as equipment for stand-alone use, or field installed.
4. The "recognition" service tests OEM components. UL defines components as devices that are factory installed in UL Listed, certified or classified end-product equipment.

The two services that apply to Warner Electric clutch/brake products are the last two: "Listing" and "Recognition." A product that is UL Listed has been successfully tested as an end-product for stand-alone use. A product that is UL Recognized has been successfully tested as a component.

The use of UL Recognized components simplifies the additional procedures required to achieve a higher UL category for end-use equipment. In general, all Warner Electric products with a conduit box and all packaged products are UL Listed. Other products, without a conduit box, are UL Recognized.

Products that are UL Listed are labeled with this symbol:



Products that are UL Recognized are labeled with this symbol:



### CSA

The authority for electrical standards in Canada is the Canadian Standards Association (CSA). CSA's tests and the procedure for submitting a product are similar to UL's; however, there is no reciprocal acceptance of products. Therefore, products must be sent to each organization for independent evaluation. Unlike UL in America, CSA is the only organization in Canada that can test electrical products. Also unlike UL, the same CSA mark may be used on both components and stand-alone equipment. However, components are certified only for use as part of an end-product. All Warner Electric industrial clutch/brake products are certified by CSA as components.



### UL and City Codes

Manufacturers of electrically powered equipment are not compelled legally to have their equipment UL tested. However, many municipalities and states refer to UL in their local codes. Los Angeles and Chicago, for example, maintain two of the strictest building codes in the country. Both make direct references to UL as the standard for electrical testing.



### Warner Electric and UL

When a product meets UL standards, it is entitled to carry a UL symbol. This symbol brings several benefits, perhaps the most important of which is improved product marketability. Because UL tests products for all reasonably foreseeable electrical hazards to life and property, safety conscious and users directly relate the UL symbol with product safety and reliability. Equally important, end product designers who use UL tested components save time and money in getting their end product listed.





### Packaged and Basic Products, Sizes 120-1525

To determine maximum allowable cycle rate, select the chart which covers your size clutch or brake, refer to the horizontal "Load Inertia" axis and project vertically until intersecting the applicable RPM line. Then project horizontally to the left to intersect the vertical cycle/second axis. This is the maximum cycle rate allowable for class A operation, or 105°C maximum coil temperature.

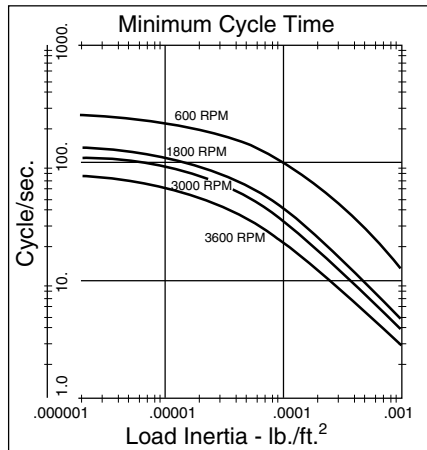

**Size 120**

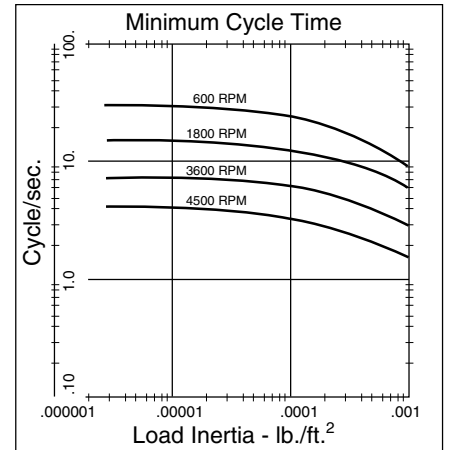

**Size 170**

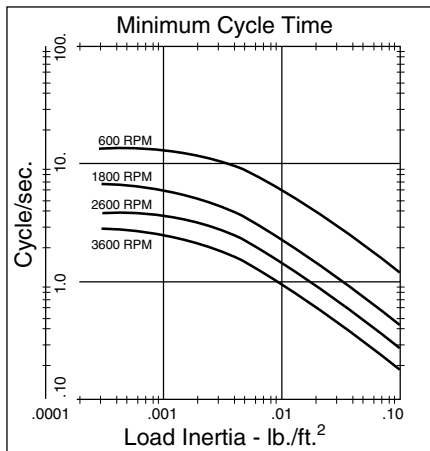

**Size 250**

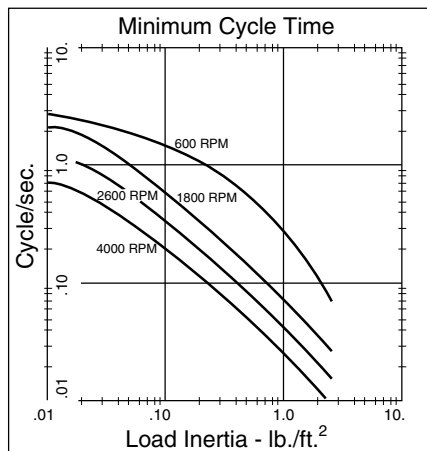

**Size 400 (EM 50)**

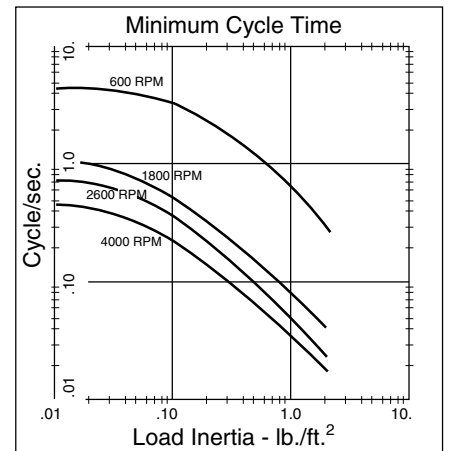

**Size 500 (EM180)**

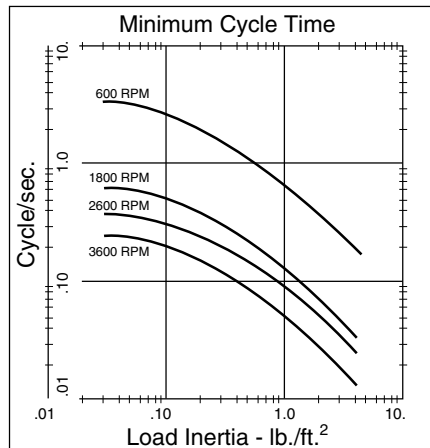

**Size 650 (EM 210 & 215)**

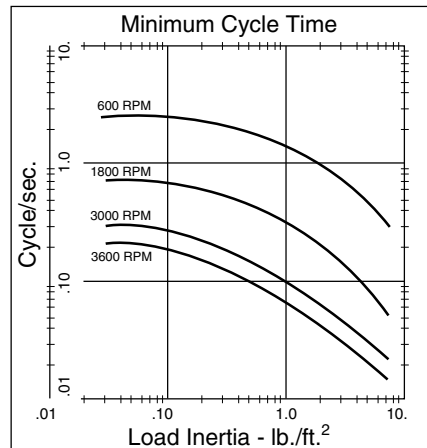

**Size 825**

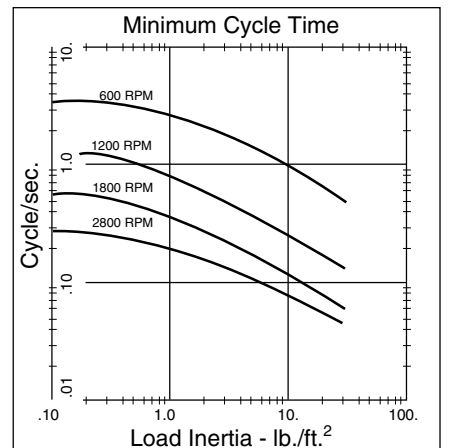

**Size 1000**

**Allowable Cycle Rates**

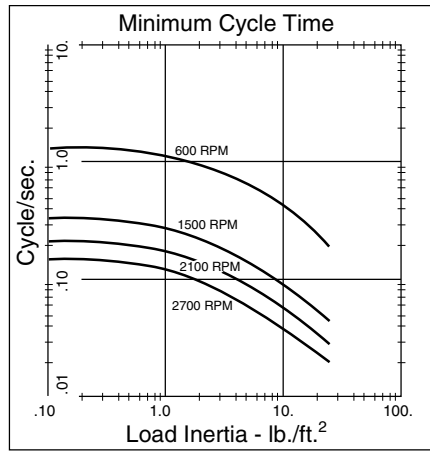

**Size 1225**

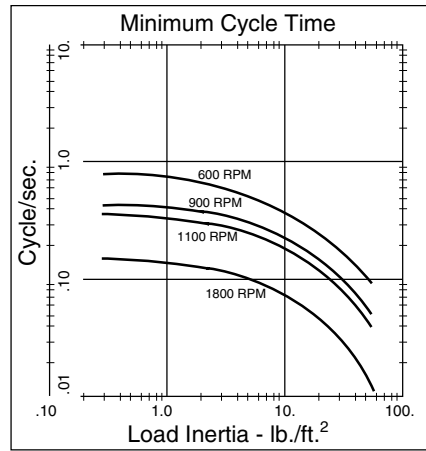

**Size 1525**

**Coil Ratings**

Unit Size	SF/PB 120			SF/PB 170			SF/PB 250											
Voltage – DC	6	24	90	6	24	90	6	24	90									
Resistance @ 20°C – Ohms	6.32	104	1386	6.96	111.2	1506	5	76.4	1079									
Current – Amperes	.949	.230	.065	.861	.215	.060	1.2	.314	.084									
Watts	5.69	5.52	5.85	5.85	5.16	5.37	7.2	7.5	7.51									
Coil Build-up – milliseconds	12	12	11	17	17	16	48	48	44									
Coil Decay – milliseconds	8	8	7	8	7	6	15	15	13									
Unit Size	SF/PB 400			SF-500			PB & PC 500			SF-650								
Voltage – DC	6	24	90	6	24	90	6	24	90	6	24	90						
Resistance @ 20°C – Ohms	4.88	73	1087	1.076	14.9	206.1	1.36	23.8	251.1	1.16	17.7	225						
Current – Amperes	1.23	.322	.083	5.58	1.61	.44	4.4	1.01	.36	5.19	1.36	.4						
Watts	7.39	7.96	7.45	34	39	39	26	24	32	31	33	36						
Coil Build-up – milliseconds	154	154	154	82	85	90	84	87	93	110	115	120						
Coil Decay – milliseconds	62	60	55	40	40	40	38	35	30	50	50	50						
Unit Size	PB-650			SF-825			SF-825 Brg			PB & PC 825			SF-1000			PB & PC 1000		
Voltage – DC	6	24	90	6	24	90	6	24	90	6	24	90	6	24	90	6	24	90
Resistance @ 20°C – Ohms	1.24	18.3	257.2	1.23	20.9	267.0	1.098	14.6	221	1.27	20.4	223.3	1.07	14.4	214.4	1.23	19.7	248.7
Current – Amperes	4.84	1.31	.35	4.9	1.15	.34	5.464	1.65	.407	4.74	1.18	.4	5.61	1.67	.42	4.87	1.22	.36
Watts	29	31	32	29	28	30	33	40	37	28	28	36	34	40	38	29	29	33
Coil Build-up – milliseconds	100	105	110	222	200	245	180	200	225	170	170	170	256	275	283	205	220	235
Coil Decay – milliseconds	50	50	50	105	120	100	115	120	130	70	75	80	123	105	90	70	75	80
Unit Size	SF-1225			PB & PC 1225			SF-1525			PB & PC 1525			SF-1525 H.T.					
Voltage – DC	6	24	90	6	24	90	6	24	90	6	24	90	6	90				
Resistance @ 20°C – Ohms	1.21	19.5	268.3	1.33	22.3	261.7	1.11	15.5	239.1	1.45	19.8	258.4	55	113.4				
Current – Amperes	4.97	1.23	.34	4.5	1.08	.34	5.41	1.55	.38	4.13	1.21	.35	10.83	.794				
Watts	30	30	30	27	26	31	32	37	34	25	29	31	65	72				
Coil Build-up – milliseconds	475	490	510	300	320	350	505	535	575	470	490	512	480	560				
Coil Decay – milliseconds	240	230	220	190	190	190	230	237	215	200	170	140	210	160				

**NOTES:**

Build-up time equals current to approximately 90% of steady state value and flux to 90%. Decay time equals current to approximately 10% of steady state value and flux to 10%. Approximately because current leads or lags flux by a small amount.

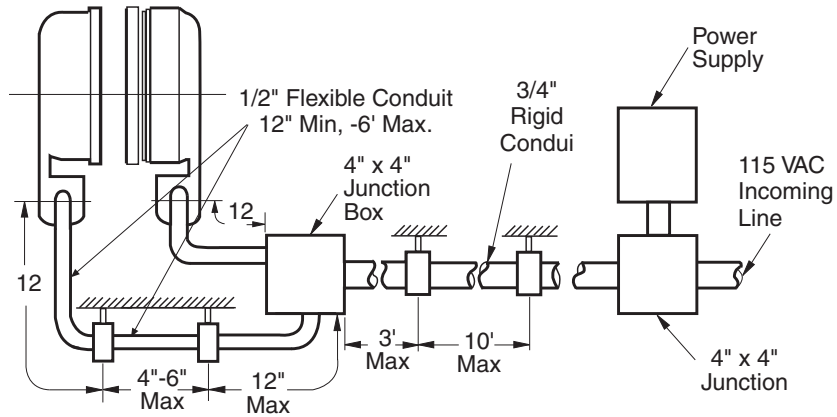

**Recommended Electrical Installation Procedure for Warner Electric Clutches and Brakes**

Warner Electric clutches and brakes conform to UL (Underwriters Laboratories) and CSA (Canadian Standards Association) requirements. All packaged products come with conduit boxes or are enclosed in housings with provision for electrical conduit connection. All sizes 400 and larger SF clutch fields and brake magnets accept UL and CSA conforming conduit boxes available from Warner Electric.

The National Electrical Code (NEC) requires that conductors subject to physical damage be adequately protected. When electrical conduit is used, a minimum of 12" of 1/2" flexible conduit is to be used between each brake and/or clutch and its box. This construction will prevent improper bearing loading in bearing mounted units and ease field and magnet assembly and disassembly. Refer

to the information below for proper installation practices and wire sizes. Notwithstanding the above recommendations, all electrical installations should conform to NEC and/or other governing electrical codes.

**Recommended wire size versus maximum distance**

Wire Size AWG	Fractional Horsepower Sizes 170-400			Integral Horsepower Sizes 500-1525		
	Distance (feet)			Distance (feet)		
	6 Volt	24 Volt	90 Volt	6 Volt	24 Volt	90 Volt
18	20	280	1000	4	65	700
16	30	430		6	95	
14	50	720		10	160	
12	75	720		10	160	
10	125			25	400	
8	200			40		

General construction wire type MTW or THW recommended.  
 #6 terminal screws (size 400 and smaller) are to be torqued to 15 in.lb.  
 #8 terminal screws (size 500 and larger) are to be torqued to 20 in.lb.

## Coil Suppression and Clutch/Brake Overlap

Users of electric clutch and brake systems are sometimes concerned that a clutch and brake will oppose each other or "overlap" during switching, i.e., when the clutch is switched off and the brake is switched on, or vice versa. This concern relates primarily to dual armature type clutch/brakes similar to the Warner Electric Electro Module product line, as compared to shuttle armature clutch/brakes.

In use, Warner Electric clutches and brakes are not subject to overlap when simple coil suppression techniques are applied to the clutch/brake control. All Warner Electric clutch/brake controls use suppression to eliminate any overlap situations.

The charts below graphically display clutch current decay and the current rise of the brake with and without current suppression. In Chart 1, which shows brake and clutch operation with suppression, the "Overlap Area" below the intersection of the brake and clutch current lines shows potential for the devices to fight one another. But this intersection occurs at an extremely low current level and the armature Autogap® springs keep the

friction surfaces of the brake armature and magnet separate at such low currents. Even though there is the appearance of a minor clutch/brake overlap in this instance, the brake armature has not yet contacted the brake magnet. Chart 2 shows a much larger overlap area since no coil suppression is used in this circuit. Clutch current has not decayed fully as the brake is engaged and the load is brought to zero speed.

Clutch and brake coils are inductors. Inductance is the electrical equivalent to mechanical inertia and an energized coil dissipates its energy when turned "off." Upon removal of power, polarity across an inductor reverses and current flows in the opposite direction. Without suppression in the control circuit, an arc can result from the strength of this current flow which can damage the electrical switching contacts.

Consequently, suppression circuitry has two major benefits:

- Protects the switching contacts
- Hastens coil decay

The schematics below show circuits with

no suppression and both diode and zener suppression types.

The rapid coil decay of suppression circuitry lets users enjoy the major advantages which dual armatures have over single, "shuttle" armatures. These include:

- Better heat dissipation – greater area to give off heat and more "off" time
- Longer life – two armatures absorb wear
- Self adjusting for the life of the unit
- Enhanced repeatability – armatures may remain in light contact with their mating surface, eliminating armature movement time and reducing noise and spline wear.

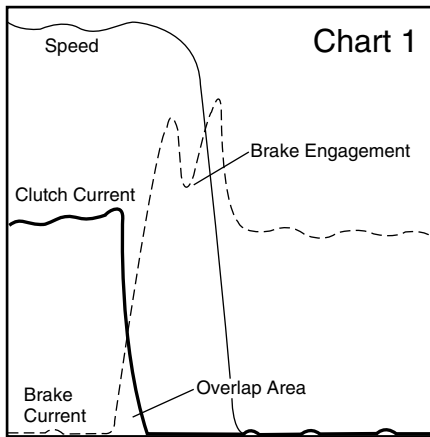

### Brake Engagement with Zener Diode Suppression

Clutch current decay and brake current rise overlap, but the brake armature is not engaged until well past the overlap point. Note that the "blip" in the brake current trace coincides with the sharp decline in the "speed" trace, indicating brake armature engagement at that point.

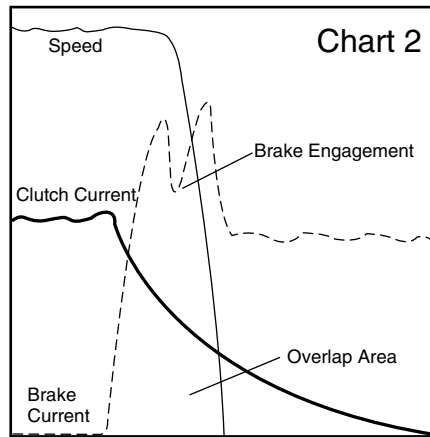

### Brake Engagement with No Suppression

Clutch current decay is much slower than with suppression as shown in Chart 1, greatly increasing the overlap area. The current level in the clutch coil is much higher at the point of brake engagement than with the suppression circuit.

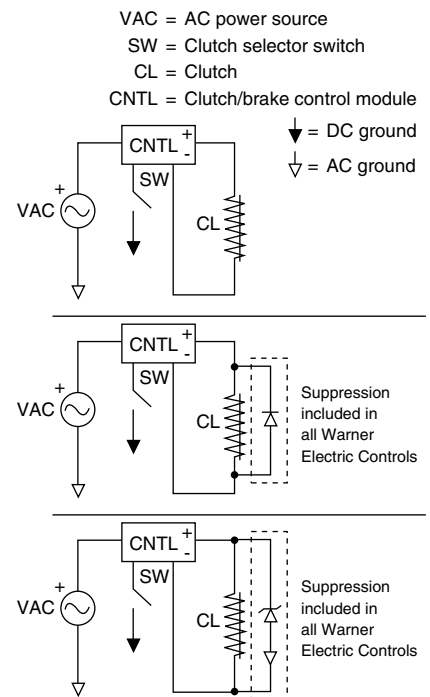

**Overexcitation**

Overexcitation is a technique which makes a clutch or brake engage faster and have greatly improved starting and stopping accuracy. It involves applying over voltage to the clutch or brake coil to reduce current build up time, thereby reducing the magnetizing time.

The graphs below show current rise and shaft speed for an identical system using a Warner Electric EP-400 clutch/brake both with and without overexcitation. The effect of overexcitation is to reduce the time needed to achieve full current and thereby reduce the time required to achieve full speed with a clutch or zero speed with a brake. In the example below, "time to start" is approximately 70 ms without overexcitation. This is

reduced to 30 ms when overexcitation is applied. This time is comparable to the coil buildup times stated on page 248. The "time to stop" has been similarly reduced; the nominally excited system requires about 110 ms to stop the load, while this is accomplished in only 50 ms with overexcitation.

Overexcitation does not increase torque. Rather, the reduction in start-stop times comes from reduced coil current build up times (or "time to current"). For many common industrial applications, the reduction in "time to speed" and "time to stop" is one half when using overexcitation.

The use of overexcitation on a

clutch/brake system does not increase system wear. In fact, the clutch/brake wear rate may be reduced because slippage and energy dissipation is marginally reduced in the clutch/brake. Compliance in the drivetrain may absorb some of the start/stop inertia or wear may be observed in other drivetrain components. Whenever overexcitation is used, adequate coil suppression must be employed. Please refer to "Coil Suppression and Clutch/Brake Overlay" on page 250.

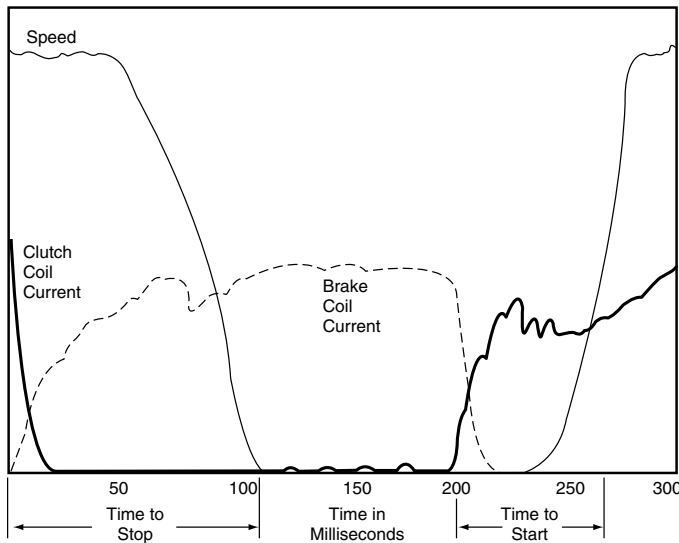

**Chart 1**

**Without Overexcitation**

Current/speed trace of EP400 clutch/brake being run through a single stop/start cycle. Note that 110 milliseconds is required to stop from the time the clutch coil is de-energized and the brake coil is energized. At the 200 milliseconds point on the graph the clutch coil is energized and the load is at speed 70 milliseconds later. Note that the coil current is still increasing after the load is at full speed.

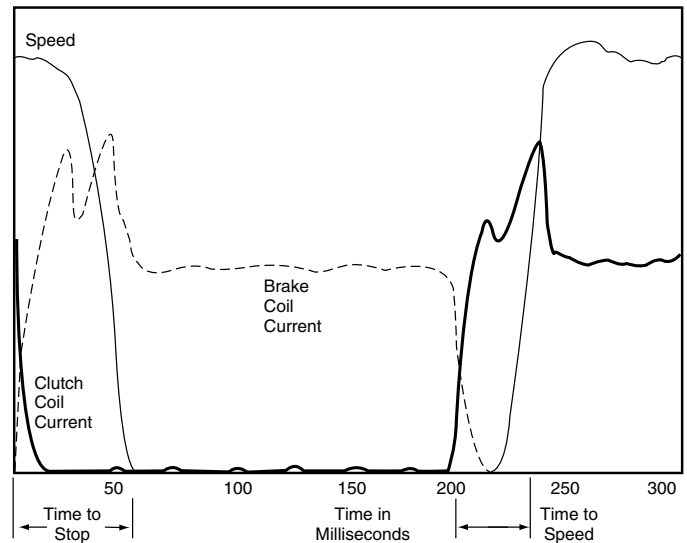

**Chart 2**

**With Overexcitation**

Current/speed trace of EP400 clutch/brake being run through a single stop/start cycle. With overexcitation, both brake and clutch coil currents build much faster with concurrent reductions in both stop and start times, when compared with Chart 1.

# Application Engineering

## Bushing Part Numbers

### Browning® Bushing

Shaft Size	Keyway Size	Bushing Number	
		Warner Electric	Browning
1/2	1/8 x 1/16	180-0002	H Type-1
9/16	1/8 x 1/16	180-0003	
5/8	3/16 x 3/32	180-0004	
11/16	3/16 x 3/32	180-0005	
3/4	3/16 x 3/32	180-0006	
13/16	3/16 x 3/32	180-0007	
7/8	3/16 x 3/32	180-0008	
15/16	1/4 x 1/8	180-0009	
1	1/4 x 1/8	180-0010	
1 1/16	1/4 x 1/8	180-0011	
1 1/8	1/4 x 1/8	180-0012	
1 3/16	1/4 x 1/8	180-0013	
1 1/4	1/4 x 1/8	180-0014	
1 5/16	5/16 x 5/32	180-0015	
1 3/8	5/16 x 5/32	180-0016	
1 7/16	3/8 x 3/16	180-0017	
1 1/2	3/8 x 3/16	180-0018	
3/4	3/16 x 3/32	180-0026	Q1 Type-1
13/16	3/16 x 3/32	180-0027	
7/8	3/16 x 3/32	180-0028	
15/16	1/4 x 1/8	180-0029	
1	1/4 x 1/8	180-0030	
1 1/16	1/4 x 1/8	180-0031	
1 1/8	1/4 x 1/8	180-0032	
1 3/16	1/4 x 1/8	180-0033	
1 1/4	1/4 x 1/8	180-0034	
1 5/16	5/16 x 5/32	180-0035	
1 3/8	5/16 x 5/32	180-0036	
1 7/16	3/8 x 3/16	180-0037	
1 1/2	3/8 x 3/16	180-0038	
1 9/16	3/8 x 3/16	180-0039	
1 5/8	3/8 x 3/16	180-0040	
1 11/16	3/8 x 3/16	180-0041	
1 3/4	3/8 x 3/16	180-0042	
1 13/16	1/2 x 1/4	180-0043	
1 7/8	1/2 x 1/4	180-0044	
1 15/16	1/2 x 1/4	180-0045	
2	1/2 x 1/4	180-0046	Q1 Type-2
2 1/16	1/2 x 1/4	180-0047	
2 1/8	1/2 x 1/4	180-0048	
2 3/16	1/2 x 1/4	180-0049	
2 1/4	1/2 x 1/4	180-0050	
2 5/16	5/8 x 5/16	180-0051	
2 3/8	5/8 x 5/16	180-0052	
2 7/16	5/8 x 5/16	180-0053	
2 1/2	5/8 x 5/16	180-0054	
2 9/16	5/8 x 5/16	180-0055	
2 5/8	5/8 x 5/16	180-0056	
2 11/16	5/8 x 5/16	180-0057	

(Browning® is registered to Emerson Electric Co.)

### Dodge Bushing

Shaft Size	Keyway Size	Bushing Number	
		Warner Electric	Dodge
1/2	1/8 x 1/16	180-0101	1210
9/16	1/8 x 1/16	180-0102	
5/8	3/16 x 3/32	180-0103	
11/16	3/16 x 3/32	180-0104	
3/4	3/16 x 3/32	180-0105	
13/16	3/16 x 3/32	180-0106	
7/8	3/16 x 3/32	180-0107	
15/16	1/4 x 1/8	180-0108	
1	1/4 x 1/8	180-0109	
1 1/16	1/4 x 1/8	180-0110	
1 1/8	1/4 x 1/8	180-0111	
1 3/16	1/4 x 1/8	180-0112	
1 1/4	1/4 x 1/8	180-0113	
1/2	1/8 x 1/16	180-0116	1215
9/16	1/8 x 1/16	180-0117	
5/8	3/16 x 3/32	180-0118	
11/16	3/16 x 3/32	180-0119	
3/4	3/16 x 3/32	180-0120	
13/16	3/16 x 3/32	180-0121	
7/8	3/16 x 3/32	180-0122	
15/16	1/4 x 1/8	180-0123	
1	1/4 x 1/8	180-0124	
1 1/16	1/4 x 1/8	180-0125	
1 1/8	1/4 x 1/8	180-0126	
1 3/16	1/4 x 1/8	180-0127	
1 1/4	1/4 x 1/8	180-0128	
1/2	1/8 x 1/16	180-0131	1615
9/16	1/8 x 1/16	180-0132	
5/8	3/16 x 3/32	180-0133	
11/16	3/16 x 3/32	180-0134	
3/4	3/16 x 3/32	180-0135	
13/16	3/16 x 3/32	180-0136	
7/8	3/16 x 3/32	180-0137	
15/16	1/4 x 1/8	180-0138	
1	1/4 x 1/8	180-0139	
1 1/16	1/4 x 1/8	180-0140	
1 1/8	1/4 x 1/8	180-0141	
1 3/16	1/4 x 1/8	180-0142	
1 1/4	1/4 x 1/8	180-0143	
1 5/16	5/16 x 5/32	180-0144	
1 3/8	5/16 x 5/32	180-0145	
1 7/16	3/8 x 3/16	180-0146	
1 1/2	3/8 x 3/16	180-0147	
1 9/16	3/8 x 3/16	180-0148	
1 5/8	3/8 x 3/16	180-0149	
1/2	1/8 x 1/16	180-0155	2012
9/16	1/8 x 1/16	180-0156	
5/8	3/16 x 3/32	180-0157	
11/16	3/16 x 3/32	180-0158	
3/4	3/16 x 3/32	180-0159	
13/16	3/16 x 3/32	180-0160	
7/8	3/16 x 3/32	180-0161	
15/16	1/4 x 1/8	180-0162	
1	1/4 x 1/8	180-0163	
1 1/16	1/4 x 1/8	180-0164	
1 1/8	1/4 x 1/8	180-0165	
1 3/16	1/4 x 1/8	180-0166	
1 1/4	1/4 x 1/8	180-0167	

Shaft Size	Keyway Size	Bushing Number	
		Warner Electric	Dodge
15/16	5/16 x 5/32	180-0168	2012
13/8	5/16 x 5/32	180-0169	
17/16	3/8 x 3/16	180-0170	
1 1/2	3/8 x 3/16	180-0171	
19/16	3/8 x 3/16	180-0172	
15/8	3/8 x 3/16	180-0173	
1 1/16	3/8 x 3/16	180-0174	
1 3/4	3/8 x 3/16	180-0175	
1 13/16	1/2 x 1/4	180-0176	
1 7/8	1/2 x 1/4	180-0177	
1 15/16	1/2 x 1/4	180-0178	
2	1/2 x 1/4	180-0179	
1/2	1/8 x 1/16	180-0185	
9/16	1/8 x 1/16	180-0186	
5/8	3/16 x 3/32	180-0187	
11/16	3/16 x 3/32	180-0188	
3/4	3/16 x 3/32	180-0189	
13/16	3/16 x 3/32	180-0190	
7/8	3/16 x 3/32	180-0191	
15/16	1/4 x 1/8	180-0192	
1	1/4 x 1/8	180-0193	
1 1/16	1/4 x 1/8	180-0194	
1 1/8	1/4 x 1/8	180-0195	
1 3/16	1/4 x 1/8	180-0196	
1 1/4	1/4 x 1/8	180-0197	
15/16	5/16 x 5/32	180-0198	
13/8	5/16 x 5/32	180-0199	
17/16	3/8 x 3/16	180-0200	
1 1/2	3/8 x 3/16	180-0201	
19/16	3/8 x 3/16	180-0202	
15/8	3/8 x 3/16	180-0203	
1 1/16	3/8 x 3/16	180-0204	
1 3/4	3/8 x 3/16	180-0205	
1 13/16	1/2 x 1/4	180-0206	
1 7/8	1/2 x 1/4	180-0207	
1 15/16	1/2 x 1/4	180-0208	
2	1/2 x 1/4	180-0209	
2 1/16	1/2 x 1/4	180-0210	
2 1/8	1/2 x 1/4	180-0211	
2 3/16	1/2 x 1/4	180-0212	
2 1/4	1/2 x 1/4	180-0213	
2 5/16	5/8 x 5/16	180-0214	
2 3/8	5/8 x 5/16	180-0215	
2 7/16	5/8 x 5/16	180-0216	
2 1/2	5/8 x 5/16	180-0217	
15/16	1/4 x 1/8	180-0223	
1	1/4 x 1/8	180-0224	
1 1/16	1/4 x 1/8	180-0225	
1 1/8	1/4 x 1/8	180-0226	
1 3/16	1/4 x 1/8	180-0227	
1 1/4	1/4 x 1/8	180-0228	
15/16	5/16 x 5/32	180-0229	
13/8	5/16 x 5/32	180-0230	
17/16	3/8 x 3/16	180-0231	
1 1/2	3/8 x 3/16	180-0232	
19/16	3/8 x 3/16	180-0233	
15/8	3/8 x 3/16	180-0234	

Shaft Size	Keyway Size	Bushing Number	
		Warner Electric	Dodge
1 11/16	3/8 x 3/16	180-0235	3020
1 3/4	3/8 x 3/16	180-0236	
1 13/16	1/2 x 1/4	180-0237	
1 7/8	1/2 x 1/4	180-0238	
1 15/16	1/2 x 1/4	180-0239	
2	1/2 x 1/4	180-0240	
2 1/16	1/2 x 1/4	180-0241	
2 1/8	1/2 x 1/4	180-0242	
2 3/16	1/2 x 1/4	180-0243	
2 1/4	1/2 x 1/4	180-0244	
2 5/16	5/8 x 5/16	180-0245	
2 3/8	5/8 x 5/16	180-0246	
2 7/16	5/8 x 5/16	180-0247	
2 1/2	5/8 x 5/16	180-0248	
2 9/16	5/8 x 5/16	180-0249	
2 5/8	5/8 x 5/16	180-0250	
2 11/16	5/8 x 5/16	180-0251	
2 3/4	5/8 x 5/16	180-0252	
2 13/16	3/4 x 3/8	180-0253	
2 7/8	3/4 x 3/8	180-0254	
2 15/16	3/4 x 3/8	180-0255	
3	3/4 x 3/8	180-0256	
15/16	1/4 x 1/8	180-0262	
1	1/4 x 1/8	180-0263	
1 1/16	1/4 x 1/8	180-0264	
1 1/8	1/4 x 1/8	180-0265	
1 3/16	1/4 x 1/8	180-0266	
1 1/4	1/4 x 1/8	180-0267	
15/16	5/16 x 5/32	180-0268	
13/8	5/16 x 5/32	180-0269	
17/16	3/8 x 3/16	180-0270	
1 1/2	3/8 x 3/16	180-0271	
19/16	3/8 x 3/16	180-0272	
15/8	3/8 x 3/16	180-0273	
1 11/16	3/8 x 3/16	180-0274	
1 3/4	3/8 x 3/16	180-0275	
1 13/16	1/2 x 1/4	180-0276	
1 7/8	1/2 x 1/4	180-0277	
1 15/16	1/2 x 1/4	180-0278	
2	1/2 x 1/4	180-0279	
2 1/16	1/2 x 1/4	180-0280	
2 1/8	1/2 x 1/4	180-0281	
2 3/16	1/2 x 1/4	180-0282	
2 1/4	1/2 x 1/4	180-0283	
2 5/16	5/8 x 5/16	180-0284	
2 3/8	5/8 x 5/16	180-0285	
2 7/16	5/8 x 5/16	180-0286	
2 1/2	5/8 x 5/16	180-0287	
2 9/16	5/8 x 5/16	180-0288	
2 5/8	5/8 x 5/16	180-0289	
2 11/16	5/8 x 5/16	180-0290	
2 3/4	5/8 x 5/16	180-0291	
2 13/16	3/4 x 3/8	180-0292	
2 7/8	3/4 x 3/8	180-0293	
2 15/16	3/4 x 3/8	180-0294	
3	3/4 x 3/8	180-0295	

## Bushing Part Numbers

Shaft Size	Keyway Size	Bushing Number		
		Warner Electric	Dodge	
1/2	1/8 x 1/16	180-0326	1610	
9/16	1/8 x 1/16	180-0327		
5/8	3/16 x 3/32	180-0328		
11/16	3/16 x 3/32	180-0329		
3/4	3/16 x 3/32	180-0330		
13/16	3/16 x 3/32	180-0331		
7/8	3/16 x 3/32	180-0332		
15/16	1/4 x 1/8	180-0333		
1	1/4 x 1/8	180-0334		
1 1/16	1/4 x 1/8	180-0335		
1 1/8	1/4 x 1/8	180-0336		
1 3/16	1/4 x 1/8	180-0337		
1 1/4	1/4 x 1/8	180-0338		
15/16	5/16 x 5/32	180-0339		
13/8	5/16 x 5/32	180-0340		
17/16	3/8 x 3/16	180-0341		
1 1/2	3/8 x 3/16	180-0342		
19/16	3/8 x 3/16	180-0343		
15/8	3/8 x 3/16	180-0344		
1/2	1/8 x 1/16	180-0410	1008	
9/16	1/8 x 1/16	180-0411		
5/8	3/16 x 3/32	180-0412		
11/16	3/16 x 3/32	180-0413		
3/4	3/16 x 3/32	180-0414		
13/16	3/16 x 3/32	180-0415		
7/8	3/16 x 3/32	180-0416		
15/16	1/4 x 1/8	180-0417		
1	1/4 x 1/8	180-0418		
1/2	1/8 x 1/16	180-0421		1310
9/16	1/8 x 1/16	180-0422		
5/8	3/16 x 3/32	180-0423		
11/16	3/16 x 3/32	180-0424		
3/4	3/16 x 3/32	180-0425		
13/16	3/16 x 3/32	180-0426		
7/8	3/16 x 3/32	180-0427		
15/16	1/4 x 1/16	180-0428		
1	1/4 x 1/8	180-0429		
1 1/16	1/4 x 1/8	180-0430		
1 1/8	1/4 x 1/8	180-0431		
1 3/16	1/4 x 1/8	180-0432		
1 1/4	1/4 x 1/8	180-0433		
15/16	5/16 x 5/32	180-0434		
13/8	5/16 x 5/32	180-0435		

# Application Engineering

## Conversion Factors

To Obtain Length:	Multiply Number of:	By:
cm	inches	2.540
cm	feet	30.48
inches	cm	.3937
inches	feet	12.0
feet	cm	$3.281 \times 10^{-2}$
feet	inches	$8.333 \times 10^{-2}$

### Torque

dyne cm	gm cm	980.7
dyne cm	oz in	$7.062 \times 10^4$
dyne cm	lb ft	$1.356 \times 10^7$
gm cm	dyne cm	$1.020 \times 10^{-3}$
gm cm	oz in	72.01
gm cm	lb ft	$1.383 \times 10^4$
oz in	dyne cm	$1.416 \times 10^{-5}$
oz in	gm cm	$1.389 \times 10^{-2}$
oz in	lb ft	192.0
lb ft	dyne cm	$7.376 \times 10^{-8}$
lb ft	gm cm	$7.233 \times 10^{-5}$
lb ft	oz in	$5.208 \times 10^{-3}$
lb ft	kg m	7.233
lb ft	Nm	.738

### Rotation

degrees/sec	RPM	6.0
degrees/sec	rad/sec	57.30
RPM	degrees/sec	.1667
RPM	rad/sec	9.549
rad/sec	degrees/sec	$1.745 \times 10^{-2}$
rad/sec	RPM	.1047

### Moment of Inertia

gm cm <sup>2</sup>	oz in <sup>2</sup>	182.9
gm cm <sup>2</sup>	lb ft <sup>2</sup>	$4.214 \times 10^5$
gm cm <sup>2</sup>	slug ft <sup>2</sup>	$1.356 \times 10^7$
oz in <sup>2</sup>	gm cm <sup>2</sup>	$5.467 \times 10^{-3}$
oz in <sup>2</sup>	lb ft <sup>2</sup>	$2.304 \times 10^3$
oz in <sup>2</sup>	slug ft <sup>2</sup>	$7.412 \times 10^4$
lb in <sup>2</sup>	lb ft <sup>2</sup>	144.0
lb in sec <sup>2</sup>	lb ft <sup>2</sup>	.37272
lb ft <sup>2</sup>	gm cm <sup>2</sup>	$2.373 \times 10^{-6}$
lb ft <sup>2</sup>	oz in <sup>2</sup>	$4.340 \times 10^{-4}$
lb ft <sup>2</sup>	slug ft <sup>2</sup>	32.17
lb ft <sup>2</sup>	Kgm <sup>2</sup>	23.73
slug ft <sup>2</sup>	gm cm <sup>2</sup>	$7.376 \times 10^{-8}$
slug ft <sup>2</sup>	oz in <sup>2</sup>	$1.349 \times 10^{-5}$
slug ft <sup>2</sup>	lb ft <sup>2</sup>	$3.108 \times 10^{-2}$

### Power

HP	(oz in) (RPM)	$9.917 \times 10^{-7}$
HP	(#ft) (RPM)	$1.904 \times 10^{-4}$
HP	watts	$1.341 \times 10^{-3}$
Watts	(oz in) (RPM)	$7.395 \times 10^{-4}$
Watts	(#ft) (RPM)	.1420
Watts	HP	745.7



### Acceleration Time, Engagement Time

The time required to change the speed of a system from the moment the clutch receives the appropriate electrical signal until the clutch is statically engaged and the system is moving at its maximum speed.

### Annealing

The "softening" of metal by heating and slow cooling. This is done on clutch and brake magnets, armatures, and rotors to ensure rapid and complete magnetizing and demagnetizing.

### Anti-Backlash Armature

A spring-mounted armature designed to eliminate backlash and noises caused by the armature dragging.

### Autogap®

A Warner Electric patented spring loaded device in clutches and brakes that automatically separates the armature from the friction face and adjusts for wear. Available in Warner Electric units 2.5" diameter and above.

### Backing Plate

The circular formed steel plate on which armature segments are welded.

### Bearing Mount

A means of mounting SF and SFC clutch fields. The other method of field mounting is called "flange-mounted."

### British Thermal Unit (BTU)

The heat required to raise the temperature of 1 lb. of water 1° F at a stated temperature.

### Brushes

Electrical conductors made of carbon which transfer electricity to a rotating collector ring. Brushes are used on Warner Electric PC and PCC clutches which employ rotating magnets.

### Build Up Time

The time in seconds required to build up to 90% of rated flux which corresponds to 80% rated torque.

### Burnishing

The process of rubbing mating friction surfaces together for maximum torque, sometimes referred to as "wearing in."

### Collector Ring

A circular electrical conductor (ring) which, while moving, is able to transfer current from stationary brushes. The collector ring is used on Warner Electric PC and PCC clutches.

### CSA

Canadian Standards Association—an organization which tests electrical equipment for product safety—similar to Underwriters Laboratory in U.S.

### Decay Time

The time in seconds required to decay to 10% of rated flux, which corresponds to 1% of rated torque, on de-energization of the unit.

### Deceleration Time, Engagement Time

The time required to stop a system from the moment the brake receives the appropriate electrical signal until the brake is statically engaged and the system is at rest.

### Energy (ft. lb.)

A measure of heat  $\times 0.00128593 = \text{B.T.U.}$   
 $e$  (Base of nature logarithms)  
 $= 2.7182818285.$

### Field

A component part of Warner Electric SF clutches consisting of a steel shell and a coil.

### Field and Rotor

Part of SF and SFC clutches which incorporates the non-rotating magnetic field and the rotating friction surface.

### Flange

Mounting plate located on the back of brake magnets and clutch fields.

### Force

That which changes or tends to change the state of rest or motion of a body.

### Gap

The distance between armature and magnetic poles in clutches and brakes when the unit is in an inactive state (i.e., disengaged).

### Glaze

A polished, slick and shiny condition that occurs on the face of friction material. Glaze is not a desired condition.

### Heat Dissipation Rate

The capability of a clutch or brake to dissipate energy in the form of heat that is generated in a given time interval.

### Horsepower

33,000 ft. lbs. per minute.

### Inertia

That property of a body to continue in the state of motion or rest in which it may be placed until acted upon by some force.

### I.M. or Inside Mounted

Refers to the location of the mounting holes on the flange of magnets or fields.

### K Factor

Maximum torque which a motor can produce momentarily.

### Kinetic Energy

Energy of a body possessed by virtue of its velocity.

## Glossary of Terms

### LK

A low coefficient friction material for certain clutches and brakes. Reduces torque and increases life. Very useful for slipping application and "soft" starts and stops.

### Moment of Inertia (WR<sup>2</sup>)

Weight of an object times (the object's radius of gyration)<sup>2</sup>.

### O.M. or Outside Mounted

Refers to the location of the mounting holes on the flange of magnets or fields.

### Overexcitation (O.E.)

A condition of applying momentary (short duration) high voltage to clutches and brakes for ultra-fast engagement. Warner Electric manufactures several special O.E. power supplies.

### Pin Drive

A type of armature drive which uses pins to hold the armature to the hub, pulley, gear, or other rotating part. Two other types of Warner Electric armature drives are "spline drive" and "antibacklash."

### Poles

1. Refers to magnet poles:  
North/South poles
2. The edge of a Warner Electric magnet shell, through which magnetic flux flows.

### Potential Energy

Energy of a body possessed by virtue of its configuration.

### Potting Compound

The material in some magnets which is a filler between the coil and shell. Used to secure and insulate the coil and eliminate damage from vibration.

### Residual Magnetism

The condition in magnets where low level magnetism remains after the electric current is removed.

### Rotor

The rotating member of a stationary field clutch—carries the friction material facing.

### Segments

Pie-shaped steel pieces that comprise the friction surface of an armature. The segmented construction permits more effective heat dissipation without distortion or surface warping.

### Shell

The steel outer casing of a magnet or field in which the coil, potting material, and friction material is placed.

### Shock Load

The load seen by a clutch or brake in a system which transmits high peak loads such as from an internal combustion engine, particularly a diesel engine, a reciprocating type compressor, an unbalanced load condition, etc.

### Slug

The mass which will acquire an acceleration of one ft. per sec<sup>2</sup> when acted upon by a force of one lb. Wt.

### Slug – Ft<sup>2</sup>

Moment of inertia equal to: lb.ft.<sup>2</sup> = 32.1739 x slug ft.<sup>2</sup>.

### Spline Drives

A gear drive which provides axial freedom and a positive radial connection (i.e., Torque, Rotation). Typically used in Warner Electric spline drive armatures.

### Static Friction

That friction which opposes motion when there is no slipping.

### Torque

The product of the force and the perpendicular distance from its line of action to the instantaneous center of rotation. Its physical unit is the poundal ft. and its technical unit is the lb.ft. Two types of torque define clutch and brake performance:

Static: The torque which is developed when there is no relative motion or slippage between the mating friction surfaces. A clutch locked in and driving or a brake holding a load both exhibit static torque. All standard units are rated on the basis of static torque, after burnishing.

Dynamic: The torque developed when there is relative motion between the mating friction surfaces. The torque varies inversely with the amount of slip, so specific values must be taken from engineering data.

### Undercut

A process of cutting back one surface as compared to another such as the friction material from the magnet poles to allow burnishing of the pole edges.

## Clutches

### SF (Stationary Field)

Model	Function	Mounting	Master Catalog	
			Pg.	Drawing
SF-120	Clutch	Flange	14	I-25508
SF-120	Clutch	Bearing	16	I-25509
SF-170	Clutch	Flange	18	I-25754
SF-170	Clutch	Bearing	20	I-25755
SF-250	Clutch	Flange	22	I-25520
SF-250	Clutch	Bearing	24	I-25521
SF-400	Clutch	Flange	26	I-25695
SF-400	Clutch	Bearing	28	I-25696
SF-500	Clutch	Bearing	30	I-25715
SF-650	Clutch	Flange Inside Outside	32	I-25749
SF-650	Clutch	Bearing IM	34	I-25750
SF-825	Clutch	Normal Duty–Flange Inside Outside	36	I-25560
		Heavy Duty–Flange Inside Outside	40	I-25561
SF-825	Clutch	Normal Duty–Bearing	38	I-25575
		Heavy Duty–Bearing	42	I-25573
SF-1000	Clutch	Normal Duty–Flange Inside Outside	44	I-25580
		Heavy Duty–Flange Inside Outside	48	I-25581
SF-1000	Clutch	Normal Duty–Bearing	46	I-25596
		Heavy Duty–Bearing	50	I-25597
SF-1225	Clutch	Normal Duty–Flange Inside Outside	52	I-25600
		Heavy Duty–Flange Inside Outside	54	I-25601
SF-1225	Clutch	Normal Duty–Bearing	56	I-25621
		Heavy Duty–Bearing	58	I-25622
SF-1525	Clutch	Normal Duty–Flange Inside Outside	60	I-25625
		Heavy Duty–Flange Inside Outside	62	I-25626
SF-1525	Clutch	Normal Duty–Bearing	64	I-25639
SF-1525	Clutch	Heavy Duty–Bearing	66	I-25640
SF-1525 H.T.	Clutch	Inside–Flange	68	I-25627
SF-1525 H.T.	Clutch	Bearing	70	I-25643

### PC (Primary)

Model	Function	Mounting	Master Catalog	
			Pg.	Drawing
PC-500	Clutch		72	I-25716
PC-825	Clutch	Normal Duty	74	I-25562
		Heavy Duty	76	I-25563
PC-1000	Clutch	Normal Duty	78	I-25582
		Heavy Duty	80	I-25583
PC-1225	Clutch	Normal Duty	82	I-25602
		Heavy Duty	84	I-25603
PC-1525	Clutch	Normal Duty	86	I-25628
		Heavy Duty	88	I-25629

# Ordering Information

## Clutch Couplings Brakes

### SFC (Stationary Field)

Model	Function	Mounting	Master Catalog	
			Pg.	Drawing
SFC-120	Clutch Coupling	Flange	90	I-25503
SFC-120	Clutch Coupling	Bearing	92	I-25504
SFC-170	Clutch Coupling	Flange	94	I-25756
SFC-170	Clutch Coupling	Bearing	96	I-25757
SFC-250	Clutch Coupling	Flange	98	I-25522
SFC-250	Clutch Coupling	Bearing	100	I-25523
SFC-400	Clutch Coupling	Flange	102	I-25697
SFC-400	Clutch Coupling	Bearing	104	I-25698
SFC-500	Clutch Coupling	Normal Duty	106	I-25540
		Heavy Duty	108	I-25541
SFC-650	Clutch Coupling	Flange	110	I-25728
		Inside		
		Outside		
SFC-650	Clutch Coupling	Bearing IM	112	I-25729
SFC-825	Clutch Coupling	Flange	114	I-25564
		Inside		
		Outside		
SFC-825	Clutch Coupling	Bearing	116	I-25574
SFC-1000	Clutch Coupling	Flange	118	I-25584
		Inside		
		Outside		
SFC-1000	Clutch Coupling	Bearing	120	I-25598
SFC-1225	Clutch Coupling	Flange	122	I-25604
		Inside		
		Outside		
SCF-1225	Clutch Coupling	Bearing	124	I-25623
SFC-1525	Clutch Coupling	Flange	126	I-25630
		Inside		
		Outside		
SFC-1525	Clutch Coupling	Bearing	128	I-25641
SFC-1525 H.T.	Clutch Coupling	Inside-Flange	130	I-25631
SFC-1525 H.T.	Clutch Coupling	Bearing	132	I-25644

### PCC (Primary)

Model	Function	Mounting	Master Catalog	
			Pg.	Drawing
PCC-500	Clutch Coupling	Normal Duty	134	I-25542
		Heavy Duty	136	I-25543
PCC-825	Clutch Coupling		138	I-25565
PCC-1000	Clutch Coupling		140	I-25585
PCC-1225	Clutch Coupling		142	I-25605
PCC-1525	Clutch Coupling		144	I-25632

### PB (Primary)

Model	Function	Mounting	Master Catalog	
			Pg.	Drawing
PB-120	Brake		147	I-25507
PB-170	Brake		148	I-25753
PB-250	Brake	Flange	150	I-25519
PB-400	Brake	Flange	152	I-25694
PB-500	Brake	Normal Duty	154	I-25544
		Inside		
		Outside		
		Heavy Duty	156	I-25550
		Inside		
		Outside		
PB-650	Brake		158	I-25730
		Inside		
		Outside		
PB-825	Brake	Normal Duty	160	I-25566
		Inside		
		Outside		
		Heavy Duty	162	I-25567
		Inside		
		Outside		
PB-1000	Brake	Normal Duty	164	I-25586
		Inside		
		Outside		
		Heavy Duty	166	I-25587
		Inside		
		Outside		
PB-1225	Brake	Normal Duty	168	I-25606
		Inside		
		Outside		
		Heavy Duty	170	I-25607
		Inside		
		Outside		
PB-1525	Brake	Normal Duty	172	I-25633
		Heavy Duty	174	I-25634

### MB (Motor Brake)

Model	Function	Mounting	Master Catalog	
			Pg.	Drawing
MB-825	Motor Brake	Normal Duty	176	I-25572
		Heavy Duty	178	I-25576
MB-1000	Motor Brake	Normal Duty	180	I-25591
		Heavy Duty	182	I-25595
MB-1225	Motor Brake	Normal Duty	184	I-25614
		Heavy Duty	186	I-25618

## Clutch/Brakes Clutch/Brake Couplings

### PCB (Primary)

Model	Function	Mounting	Master Catalog	
			Pg.	Drawing
PCB-825	Clutch Brake	Normal Duty Inside	188	I-25568
		Outside Heavy Duty Inside	190	I-25569
PCB-1000	Clutch Brake	Normal Duty Inside	192	I-25588
		Outside Heavy Duty Inside	194	I-25589
PCB-1225	Clutch Brake	Normal Duty Inside	200	I-25608
		Outside Heavy Duty Inside	202	I-25609
PCB-1225/ 1000	Clutch Brake	Normal Duty Inside	196	I-25610
		Outside Heavy Duty Inside	198	I-25611
PCB-1525/ 1225	Clutch Brake	Normal Duty Inside	204	I-25635
		Outside Heavy Duty Inside	206	I-25636

### SFPBC (Stationary Field)

Model	Function	Mounting	Master Catalog	
			Pg.	Drawing
SFPBC-500	Clutch Brake Coupling	Normal Duty Inside	208	I-25546
		Outside Heavy Duty Inside	210	I-25554
SFPBC-650	Clutch Brake Coupling	Inside	212	I-25751
		Outside		

### PCBC (Primary)

Model	Function	Mounting	Master Catalog	
			Pg.	Drawing
PCBC-500	Clutch Brake Coupling	Normal Duty Inside	214	I-25547
		Outside Heavy Duty Inside	216	I-25553
PCBC-825	Clutch Brake Coupling	Inside Outside	218	I-25570
PCBC-1000	Clutch Brake Coupling	Inside Outside	220	I-25590
PCBC-1225	Clutch Brake Coupling	Inside Outside	224	I-25612
PCBC-1225/ 1000	Clutch Brake Coupling	Inside Outside	222	I-25613
PCBC-1525/ 1225	Clutch Brake Coupling	Inside Outside	226	I-25637

# Ordering Information

## Drawing Numbers

Model number	Function	Mounting	Page	I-drawing
SFC-120	Clutch Coupling	Flange	90	I-25503
SFC-120	Clutch Coupling	Bearing	92	I-25504
PB-120	Brake	Flange	147	I-25507
SF-120	Clutch	Flange	14	I-25508
SF-120	Clutch	Bearing	16	I-25509
PB-250	Brake	Flange	150	I-25519
SF-250	Clutch	Flange	22	I-25520
SF-250	Clutch	Bearing	24	I-25521
SFC-250	Clutch/Coupling	Flange	98	I-25522
SFC-250	Clutch Coupling	Bearing	100	I-25523
SFC-500	Clutch Coupling	Bearing ND	106	I-25540
SFC -500	Clutch Coupling	Bearing HD	108	I-25541
PCC-500	Clutch Coupling	Shaft ND	134	I-25542
PCC-500	Clutch Coupling	Shaft HD	136	I-25543
PB-500	Brake	Flange ND	154	I-25544
SFPBC-500	Clutch/brake	Flange ND	208	I-25546
PCBC-500	Clutch/brake	Flange ND	214	I-25547
PB-500	Brake	Flange HD	156	I-25550
PCBC-500	Clutch/brake	Flange HD	216	I-25553
SFPBC-500	Clutch/brake	Flange HD	210	I-25554
SF-650	Clutch	Flange ND	36	I-25560
SF-825	Clutch	Flange HD	40	I-25561
PC-825	Clutch	Shaft ND	74	I-25562
PC-825	Clutch	Shaft HD	76	I-25563
SFC-825	Clutch Coupling	Flange	114	I-25564
PCC-825	Clutch Coupling	Shaft	138	I-25565
PB-825	Brake	Flange ND	160	I-25566
PB-825	Brake	Flange HD	162	I-25567
PCB-825	Clutch/brake	Flange ND	164	I-25568
PCB-825	Clutch/brake	Flange HD	190	I-25569
PCBC-825	Clutch/brake	Flange	218	I-25570
MB-825	Motor Brake	Flange ND	176	I-25572
SF-825	Clutch	Bearing HD	42	I-25573
SFC-825	Clutch Coupling	Bearing	116	I-25574
SF-825	Clutch	Bearing ND	38	I-25575
MB-825	Motor Brake	Flange HD	178	I-25576
SF-1000	Clutch	Flange ND	44	I-25580
SF-1000	Clutch	Flange HD	48	I-25581
PC-1000	Clutch	Shaft ND	78	I-25582
PC-1000	Clutch	Shaft HD	80	I-25583
SFC-1000	Clutch Coupling	Flange	118	I-25584
PCC-1000	Clutch Coupling	Shaft	140	I-25585
PB-1000	Brake	Flange ND	164	I-25586
PB-1000	Brake	Flange HD	166	I-25587
PCB-1000	Clutch/brake	Flange ND	192	I-25588
PCB-1000	Clutch/brake	Flange HD	194	I-25589
PCBC-1000	Clutch/brake	Flange	220	I-25590
MB-1000	Motor Brake	Flange ND	180	I-25591
MB-1000	Motor Brake	Flange HD	182	I-25595
SF1000	Clutch	Bearing ND	46	I-25596
SF-1000	Clutch	Bearing HD	50	I-25597
SFC-1000	Clutch Coupling	Bearing	120	I-25598
SF-1225	Clutch	Flange ND	52	I-25600
SF-1225	Clutch	Flange HD	54	I-25601

Model number	Function	Mounting	Page	I-drawing
PC-1225	Clutch	Shaft ND	82	I-25602
PC-1225	Clutch	Shaft HD	84	I-25603
SFC-1225	Clutch Coupling	Flange	122	I-25604
PCC-1225	Clutch Coupling	Shaft	142	I-25605
PB-1225	Brake	Flange ND	168	I-25606
PB-1225	Brake	Flange HD	170	I-25607
PCB-1225	Clutch/brake	Flange ND	200	I-25608
PCB-1225	Clutch/brake	Flange HD	202	I-25609
PCB-1225/1000	Clutch/brake	Flange ND	196	I-25610
PCB-1225/1000	Clutch/brake	Flange HD	198	I-25611
PCBC-1225	Clutch/brake	Flange	224	I-25612
PCBC-1225/1000	Clutch/brake	Flange	222	I-25613
MB-1225	Motor Brake	Flange HD	184	I-25614
MB-1225	Motor Brake	Flange HD	186	I-25618
SF-1225	Clutch	Bearing ND	56	I-25621
SF-1225	Clutch	Bearing HD	58	I-25622
SFC-1225	Clutch Coupling	Bearing	124	I-25623
SF-1525	Clutch	Flange ND	60	I-25625
SF-1525	Clutch	Flange HD	62	I-25626
SF-1525 HT	Clutch	Flange	68	I-25627
PC-1525	Clutch	Shaft ND	86	I-25628
PC-1525	Clutch	Shaft HD	88	I-25629
SFC-1525	Clutch Coupling	Flange	126	I-25630
SFC-1525 HT	Clutch Coupling	Flange	130	I-25631
PCC-1525	Clutch Coupling	Shaft	144	I-25632
PB-1525	Brake	Flange ND	172	I-25633
PB-1525	Brake	Flange HD	174	I-25634
PCB-1525/1225	Clutch/brake	Flange ND	204	I-25635
PCB-1525/1225	Clutch/brake	Flange HD	206	I-25636
PCBC-1525/1225	Clutch/brake	Flange	226	I-25637
SF-1525	Clutch	Bearing ND	39	I-25627
SF-1525	Clutch	Bearing HD	66	I-25640
SFC-1525	Clutch Coupling	Bearing	128	I-25641
SF-1525 HT	Clutch	Bearing	70	I-25643
SFC-1525 HT	Clutch Coupling	Bearing	132	I-25644
PB-400	Brake	Flange	152	I-25694
SF-400	Clutch	Flange	26	I-25695
SF-400	Clutch	Bearing	28	I-25696
SFC-400	Clutch Coupling	Flange	102	I-25697
SFC-400	Clutch Coupling	Bearing	104	I-25698
SF-500	Clutch	Bearing	30	I-25715
PC-500	Clutch	Shaft	72	I-25716
SFC-650	Clutch Coupling	Flange	110	I-25728
SFC-650	Clutch Coupling	Bearing	112	I-25729
PB-650	Brake	Flange	158	I-25730
SF-650	Clutch	Flange	32	I-25749
SF-650	Clutch	Bearing	34	I-25750
SFPBC-650	Clutch/brake	Flange	212	I-25751
PB-170	Brake	Flange	148	I-25753
SF-170	Clutch	Flange	18	I-25754
SF-170	Clutch	Bearing	20	I-25755
SFC-170	Clutch Coupling	Flange	94	I-25756
SFC-170	Clutch Coupling	Bearing	96	I-25757

Warner Electric's electronic controls are designed to provide simple setup and maximum performance when used with electric clutches and brakes. Our controls offer a range of functions from on-off to torque control to over-excitation.

### Selection

Many parameters beyond function can impact control selection. Warner Electric produces a variety of control options to suit numerous application requirements. Control selection parameters include:

- Mounting Location – Panel or conduit box mounting
- Switching – Relay switching of A.C. or D.C. lines or solid state switching
- Output Voltage – Controls are available for 6, 24 and 90 VDC clutch/brake coils
- Input Voltage – Controls with input power transformers are available for connection to high voltage mains.

If your application requires something special, please call us. We will be happy to provide solutions.

### Clutch and Brake Controls . . . . . 262

#### On-Off Controls

CBC-100 . . . . .	264
CBC-150 . . . . .	264
CBC-160 . . . . .	265
CBC-801 . . . . .	266
CBC-802 . . . . .	267
CBC-400 . . . . .	268
CBC-450 . . . . .	269

#### Adjustable Torque Controls

MCS-103-1 . . . . .	270
MCS-153 . . . . .	271
CBC-200 . . . . .	272
CBC-300 . . . . .	272
CBC-500 . . . . .	273
CBC-550 . . . . .	274
CBC-1825R . . . . .	276

#### Overexcitation Controls

CBC-700 . . . . .	277
CBC-750 . . . . .	278

#### Closed Loop Position Control

CBC-1000 . . . . .	280
--------------------	-----

#### Appendix . . . . . 282

#### Questions & Answers . . . . . 283

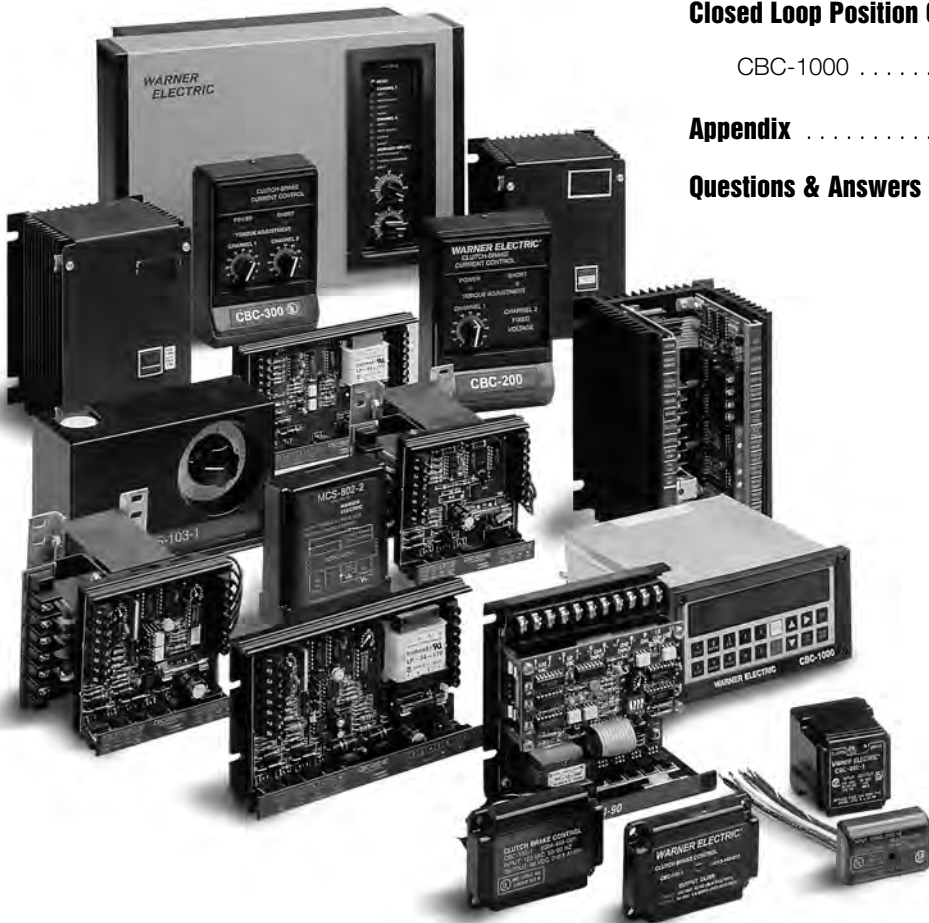

# Clutch and Brake Controls

## Functions

### On-Off (Basic start-stop)

Many applications are controlled by energizing the clutches and brakes with their rated D.C. voltages. Warner Electric controls are available with various mounting, input voltage and switching options.

### Adjustable Torque

#### (Soft start-stop)

The torque transmitted by a clutch or brake is proportional to the coil current. Warner Electric offers several products that provide torque control for smooth and repeatable starts and stops.

### Adjustable Accel-Decel

#### (Soft start-stop with full torque)

Warner Electric offers a control that allows for adjustment of the acceleration and deceleration time ramps to achieve a repeatable soft start or stop while still allowing for full torque.

### Overexcitation













#### (Rapid cycling)

The clutch/brake speed of response can be increased for improved accuracy and performance through overexcitation, which is the application of a short high voltage pulse to provide nearly instantaneous torque.

### Position Loop

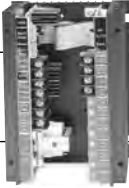
#### (Programmable cycling)

Warner Electric's CBC-1000 position loop control system offers servo system performance with electric clutch/brake economy in high accuracy indexing applications. The unique error correction capability of the CBC-1000 to achieve repeatability and accuracy makes this an ideal control for many applications.

Control Type		
On-Off Conduit Box Mount		
On-Off Octal Socket Mount		
On-Off Panel Mount		
Adjustable Torque		
Adjustable Accel-Decel		
Overexcitation		
Position Loop		



# Clutch and Brake Controls

Model Number	No. of Channels	Torque Control Channels	A.C. Input Voltages	D.C. Output Voltages	Over-Excitation	Customer Supplied Switching Options	Description	Page Number
CBC-100-1 CBC-100-2	1 1	No No	120 220/240	90	No	Relay A.C.	Single channel control to mount inside standard conduit box	264
CBC-150-1 CBC-150-2	2 2	No No	120 220/240	90	No	Relay A.C.	Dual channel control for clutch/brake to mount inside module conduit box	264
CBC-160-1 CBC-160-2	1 1	1 1	120 220/240	90	No	Relay A.C.	Single channel control with torque adjust for module electrically released brakes	265
CBC-801-1 CBC-801-2	2 2	No No	120 220/240	90	No	Relay D.C.	Dual channel control for 2 clutches and/or brakes	266
CBC-802	2	No	120	90	No	Transistor or Relay D.C.	Dual channel control with transistor switching	267
CBC-400-90 CBC-400-24 CBC-450-90 CBC-450-24	2 2 2 2	No No No No	120 24-30 120/220/240/380/480 120/220/240/380/480	90 24 90 24	No No No No	Transistor or Relay D.C.	Dual channel control for use with 2 clutches and/or brakes; Emergency stop input and AUX power supply	268
MCS-103-1	2	1	120	90	No	Relay D.C.	Dual channel control with torque adjust for one channel	270
MCS-805-1 MCS-805-2	1	1	120/240	35-75	No	Relay D.C.	Single adjustable channel control for use with ER 1225 brake	271
CBC-200	2	1	120	90	No	Transistor or Relay D.C.	Dual channel control with one adjustable current and one fixed voltage	272
CBC-300	2	2	120	90	No	Transistor or Relay D.C.	Dual channel adjustable current control	272
CBC-500-90 CBC-500-24 CBC-550-90 CBC-550-24	2 2 2 2	2 2 2 2	120 24-30 120/220/240/380/480 120/220/240/380/480	90 24 90 24	No No No No	Transistor or Relay D.C.	Dual channel control for two clutches and/or brakes with two torque adjust channels; Emergency stop input	273
CBC-1825-R	2	2	120	90	No	Transistor or Relay D.C.	Dual channel adjustable time ramp with short circuit protection	276
CBC-700-90 CBC-700-24	2 2	No No	120 24-28	90 24	Yes	Transistor or Relay D.C.	Dual channel compact overexcitation control for 24 or 90 volt clutches and brakes	277
CBC-750-6-24-90	2	2	120/220/240	6,24,90	Yes	Transistor, Relay D.C. or Triac A.C.	Dual channel full function overexcitation control; provides input/output logic, torque adjustable current and remote inputs	278
CBC-1000	2	N.A.	120/230	N.A.	N.A.	N.A.	Error correction control to be used with one of the above	280

## Integral/Conduit Box Mounted Controls

The CBC-100 and CBC-150 series are UL listed, conduit box mounted controls for 90 volt clutches and brakes. Models are available for either 120 VAC or 220/240 VAC input.



### CBC-100 series Single unit capacity

The CBC-100 mounts inside a standard Warner Electric conduit box and includes rectification and suppression circuits.

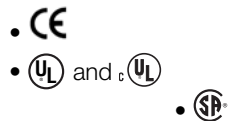

- Compact
- Single channel
- Mounts inside conduit box



### CBC-150 series Dual channel capacity

The CBC-150 replaces the cover on the standard module conduit box (part no. 5370-101-042). Provides rectification and suppression for two devices. Green LED indicates power to clutch. Red LED indicates power to brake.

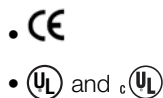

- Dual channel
- Replaces the cover on the module conduit box

### Specifications

	CBC-100-1	CBC-100-2	CBC-150-1	CBC-150-2
Part No.	6003-448-101	6003-448-103	6004-448-001	6004-448-002
Input	120 VAC 50/60 Hz	220/240 VAC 50/60 Hz	120 VAC 50/60 Hz	220/240 VAC 50/60 Hz
Output	90 VDC full wave rectified .8 Amp max.	90 VDC half wave .8 Amp	90 VDC full wave rectified Dual .8 Amp	90 VDC half wave Dual .8 Amp
Ambient Temperatures	-20° to 113°F (-29° to 45°C)			
Switching	External to control, accomplished on A.C. line using relay or triac.			
	SPST	SPST	SPDT	SPDT
Solid State (maximum leakage current <2 mA)	140 VAC, 1 Amp min.	280 VAC, 1 Amp min.	140 VAC, 2 Amp min.	280 VAC, 2 Amp min.
Electro- mechanical	120 VAC, 1 Amp min.	240 VAC, 1 Amp min.	120 VAC, 1 Amp min.	240 VAC, 1 Amp min.

### Connection diagrams

#### CBC-100-1, -2

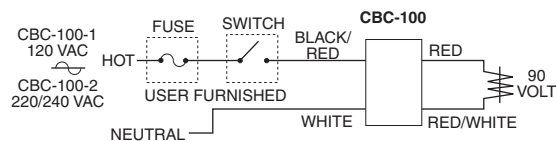

### Dimensions

#### CBC-100-1, -2

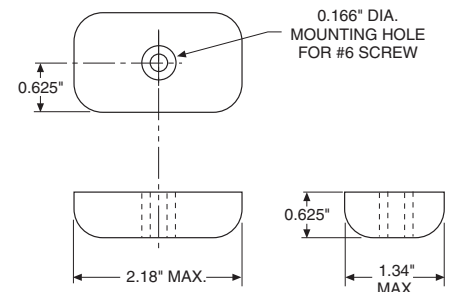

#### CBC-150-1, -2

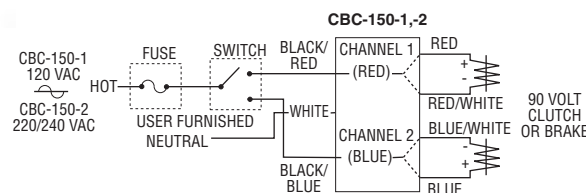

#### CBC-150-1, -2

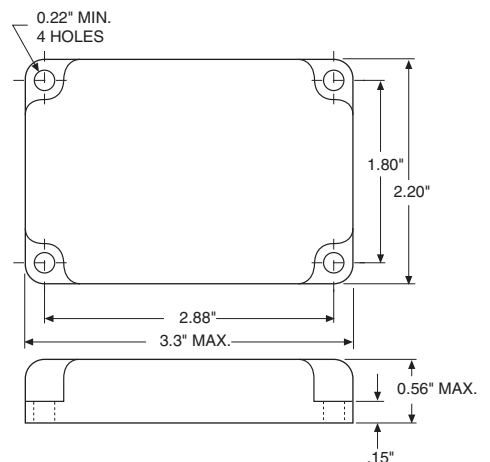

All dimensions nominal unless otherwise specified.

## Integral/Electrically Released Motor Brake Controls

### CBC-160

The CBC-160 series clutch/brake controls provide a single 90 VDC adjustable output for use with any clutch/brake unit. The adjustable output will provide consistent and repeatable release for Warner Electric's 90 VDC permanent magnet electrically released brakes.



The CBC-160 mounts as the cover on the standard module conduit box (part no. 5370-101-042).

The 160-1 accommodates 120 volts A.C. motors.



- Adjustable 30-100 VDC
- LED indicator
- 120 volt A.C. input

The power to the 160-2 control can come from either a 230 volt or 460 volt A.C. motor. Customer-provided switching is accomplished through the motor starter on the A.C. input. This allows convenient retrofit of spring-set style motor brakes and inexpensive installation of new applications.



- Adjustable 30-100 VDC
- Power from motor
- Easy retrofit
- 230/460 motors

### Dimensions

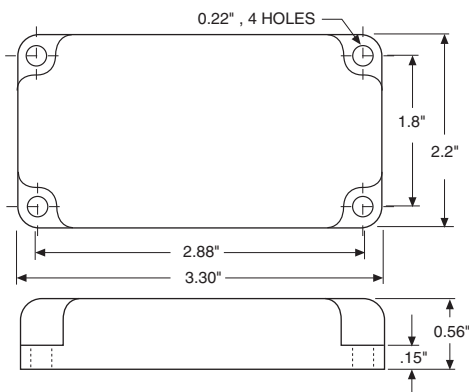

All dimensions nominal unless otherwise specified.

### Specifications

	CBC-160-1	CBC-160-2
Part No.	6013-448-001	6013-448-002
Input	120 VAC, 50/60 Hz	220/240 VAC, 60 Hz, 1 Phase, 100 VA max.
Status Indicator	Red LED indicates power to the brake	—
Output	Single Channel, 30-100 VDC half-wave rectified nominal, 0.8 Amps maximum	
Ambient Temperatures	0° to 122°F (-18° to 50°C)	
Switching	Accomplished through motor starter or on A.C. line using relay or triac	

### Connection Diagram

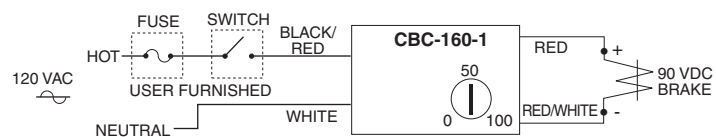

### WYE Connected Motor

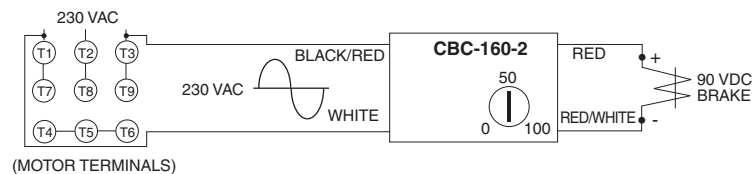
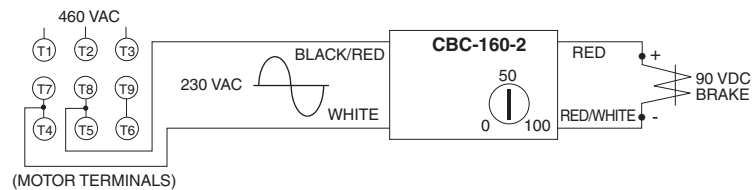

### DELTA Connected Motor

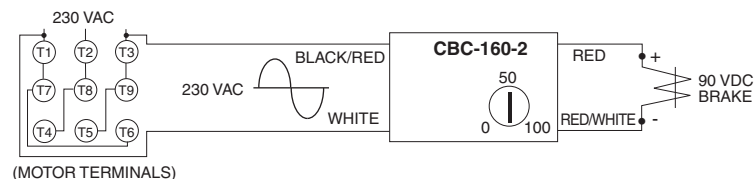
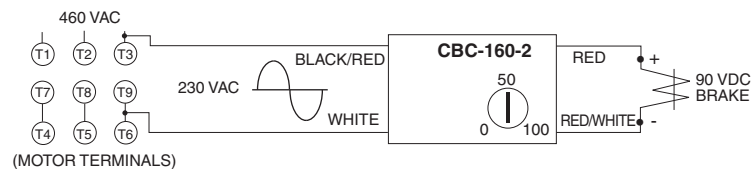

## Plug-in Octal Socket Power Supplies

The CBC-801 is a basic on-off power supply that provides full voltage to a 90 volt clutch or brake and is activated by an external switch. This type of power supply is sufficient for many clutch/brake applications.

### CBC-801 series Multi-unit capacity

The CBC-801 is a plug-in power supply which is used with an octal socket. The wiring connections are made at the socket. The CBC-801 will operate two units separately—or simultaneously. Octal socket is purchased separately.



- For basic on-off operation
- Wiring connections made at octal socket
- Arc suppression circuitry extends switch life
- Fused for overload protection
- LED output indicators
- DIN rail mountable



### Specifications

	CBC-801-1	CBC-801-2
Part No.	6001-448-004	6001-448-006
Input Voltage	120 VAC, 50/60 Hz	220/240 VAC, 50/60 Hz
Output	90 VDC, 1.25 A max.	
Circuit Protection	Fused 1.6 Amp, 250 V fast-blo	
Ambient Temperature	-23° to 116°F (-31° to 47°C)	
Max. Cycle Rate	Limited by the clutch or brake, variable with application	
Switching	Single pole, double throw Minimum contact rating: 10 Amp, 28 VDC resistive or 10 Amp, 120 VAC inductive	
Status Indicator	Red LED indicates brake is energized, Green LED indicates clutch is energized	
Mounting	Two versions of octal socket are available: 6001-101-001 foot mount 6001-101-002 DIN rail mount	

### Dimensions

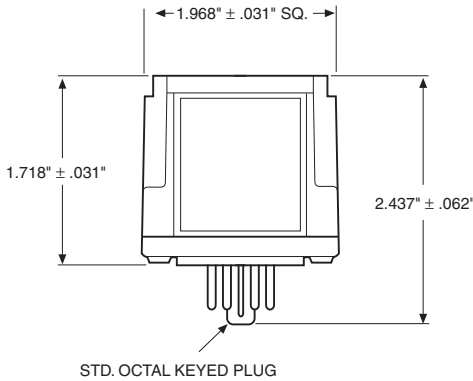

### OCTAL SOCKET

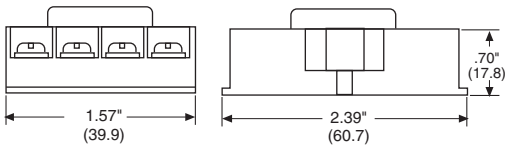

### DIN RAIL MOUNT SOCKET

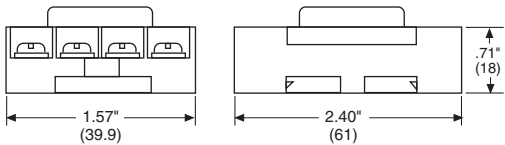

All dimensions nominal unless otherwise specified.

### Connection Diagram

Connection diagram for operating clutch/brake separately.

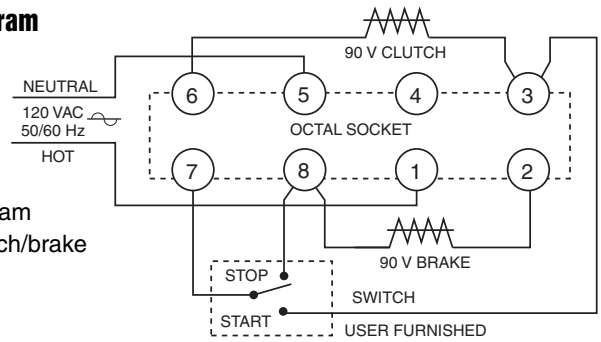

Connection diagram for operating clutch/brake simultaneously.

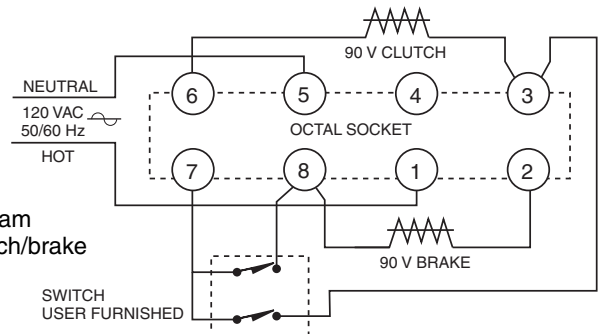

## Plug-in Octal Socket Power Supplies



### CBC-802 PLC compatible

The CBC-802 is a power supply with solid state circuits for load switching. A brake and clutch may be operated separately—or, two brakes or two clutches, one unit on at a time. The CBC-802 mounts on an octal socket (purchased separately), and the wiring connections are made at the socket terminals. Octal socket sold separately, refer to mounting specifications for part number.

- SP
- Plug-in power supply with solid state switching circuits—increases switch service life
- Adjustable time delay for controlling clutch/brake overlap
- Internally fused for overload protection
- DIN rail mountable
- LED output indicators

### Dimensions

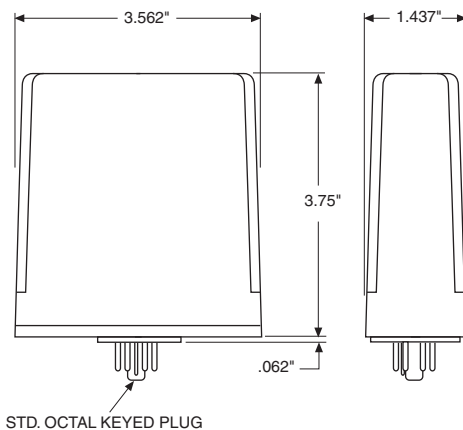

All dimensions nominal unless otherwise specified.

### Specifications

CBC-802	
Part No.	6002-448-001
Input	120 VAC, 50/60 Hz
Output	90 VDC, 0.5 A max.
Status Indicator	Red LED indicates brake energized. Green LED indicates clutch energized.
Circuit Protection	Fused 0.5 Amps, 250 V
Ambient Temperature	-20° to 113°F (-29° to 45°C)
Leakage Current	500 uA max. for solid state switches
Max. Cycle Rate	Limited by the clutch or brake, variable with application
Switching	Momentary contact, maintained contact, or solid state open collector logic Minimum contact rating 20 VDC resistive, 0.01 Amps Minimum input pulse—1 millisecond
Adjustments	Externally adjusted potentiometer sets overlap between clutch and brake from 0 to 130 MS.
Mounting:	Two versions of octal socket are available: 6001-101-001 foot mount 6001-101-002 DIN rail mount

### Connection Diagram

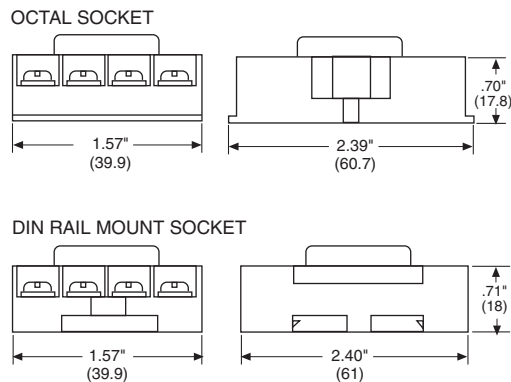
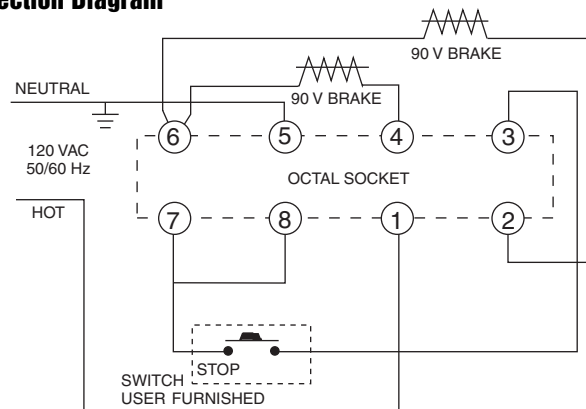

**Panel Mounted Control**



**CBC-400 series  
Dual channel controls**

The CBC-400 series is a basic on-off control which supplies 24 or 90 VDC for electric clutch/brake operation. They offer optically isolated switching inputs for start, stop, and emergency stop (E-stop). These controls can be set up to operate the two outputs alternately (single) or simultaneously (dual). Refer to the Appendix page 282 for additional setup and switching information.



- 24 or 90 Volt DC output
- Auxiliary 12V supply
- Fast coil suppression
- Single or dual channel operation
- Optically isolated input switching

**Specifications**

	<b>CBC-400-90</b>	<b>CBC-400-24</b>
Part No.	6006-448-003	6006-448-002
Input Voltage	120 VAC	24-30 VAC
Output Voltage	90 VDC	24 VDC
Output Current	1 Amp/Channel 2 Amps Total	5 Amps/Channel 5 Amps Total
Auxiliary Supply	12 VDC 250 mA	
Circuit Protection	Fused 2.5 Amp, 250 V fast-blo	Fused 6.3 Amp, 250 V fast-blo
Ambient Temperature	+32° to 122°F (0° to 50°C)	
Status Indicators	Red LED indicates channel is energized.	
Adjustments	Jumper for single or dual operation. See appendix on page 282 for explanation.	
Inputs	3 Optically isolated, 10-30 VDC, 3-9 mA for Channel 1, Channel 2 and Channel 2 override (applies full voltage to channel 1 output).	

**Enclosure (Optional)**



- Lift off hinge
- Quick-release latches
- Conforms to NEMA Type 13
- European Standard IEC 529, IP65

**Connection Diagram**

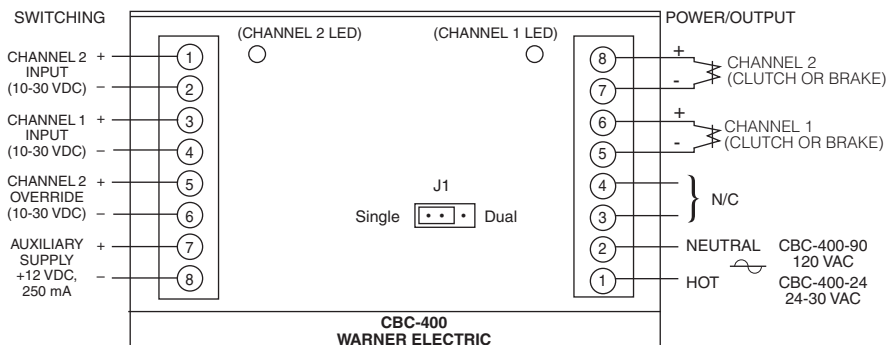

All dimensions nominal unless otherwise specified.

<b>Part No.</b>	<b>6042-101-004</b>
Size	8"H x 6"W x 4"D (203.2 x 152.4 x 101.6 mm)

**Dimensions**

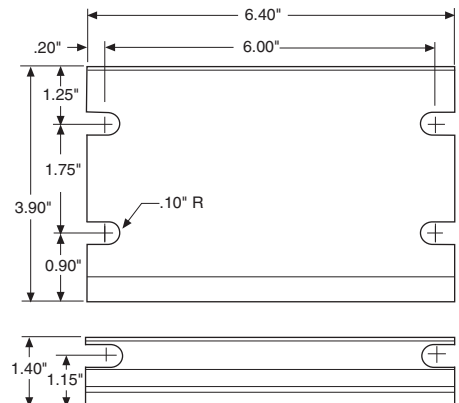

## Panel Mounted Control

### CBC-450 series Dual channel control with transformer for variable input voltage

The CBC-450 series is a basic on-off control which supplies 24 or 90 VDC for electric clutch/brake operation. They offer optically isolated switching inputs for start, stop, and emergency stop (E-stop). These controls can be set up to operate the two outputs, alternately (single) or simultaneously (dual). Refer to the Appendix page 282 for additional setup and switching information. The CBC-450 series has a power transformer which will operate with a 120, 220, 240, 380 or 480 VAC input.



### Enclosure (Optional)



- Lift off hinge
- Quick-release latches
- Conforms to NEMA Type 13
- European Standard IEC 529, IP65

<b>Part No.</b>	<b>6006-101-007</b>
Size	6"H x 6"W x 6"D (152.4 x 152.4 x 152.4 mm)



- 24 or 90 Volt DC output
- Auxiliary 12V supply
- Fast coil suppression
- Single or dual channel operation
- Optically isolated switching

### Specifications

	CBC-450-90	CBC-450-24
Part No.	6006-448-006	6006-448-005
Input Voltage	120/220/240/380/480 VAC	
Output Voltage	90 VDC	24 VDC
Output Current	1 Amp/Channel 1.2 Amps Total	4 Amps/Channel 4 Amps Total
Auxiliary Supply	12 VDC 250 mA	
Circuit Protection	Fused 1.5 Amp	Fused 5 Amp
Ambient Temperature	+32° to 122°F (0° to 50°C)	
Status Indicators	Red LED indicates channel is energized.	
Adjustments	Jumper for single or dual operation. See appendix on page 282 for explanation.	
Inputs	3 Optically isolated, 10-30 VDC, 3-9 mA for Channel 1, Channel 2 and Channel 2 override (E-stop).	

### Dimensions

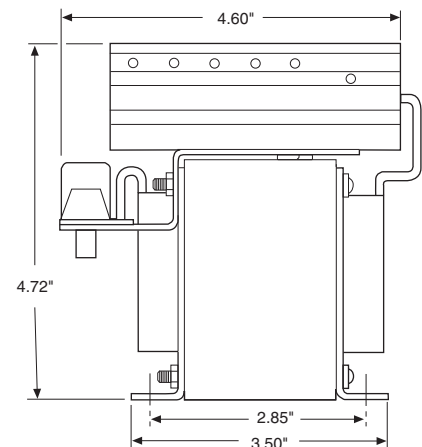
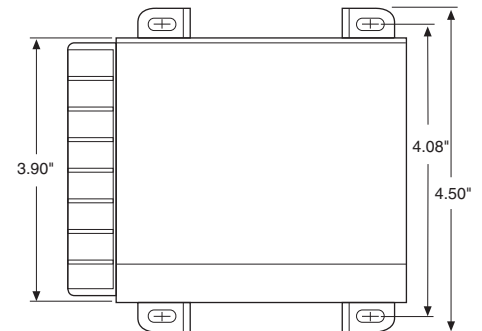

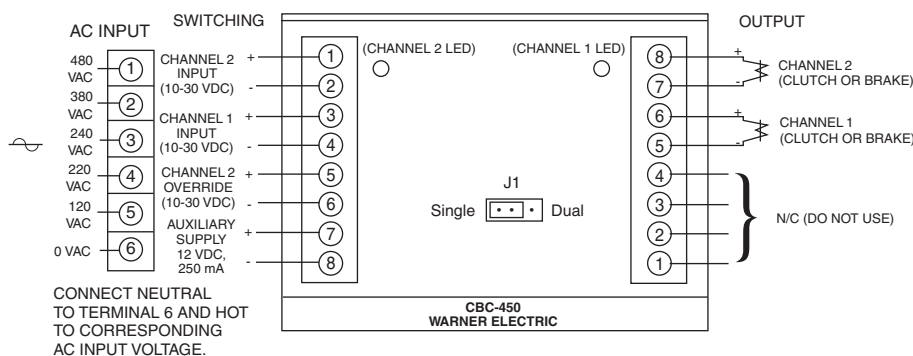

### Connection Diagram



All dimensions nominal unless otherwise specified.

## Adjustable Torque Control

The MCS-103-1 is an enclosed control complete with a cover and mounting provisions. A brake and clutch may be operated separately with this control — or up to four units, two at a time. The external wiring is connected to the terminal strip located behind the cover.

-  
- Can be used with electrically released brakes

- Torque control for one 90 VDC clutch or brake
- Operates up to four units, two on at a time
- Easy-to-install. Compact. 120 VAC input
- Convenient terminal strip behind an easy-to-remove cover



### Dimensions

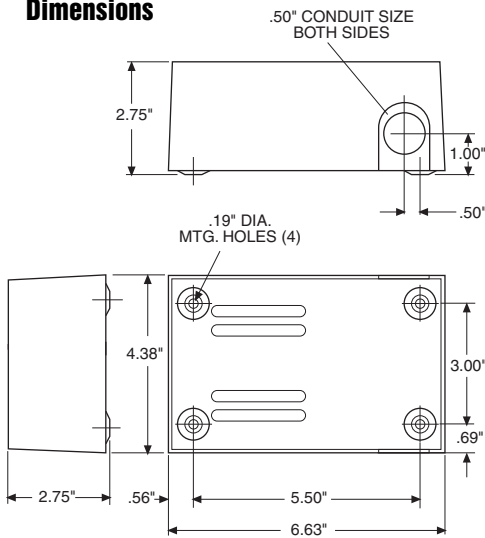

### Specifications

MCS-103-1	
Part No.	6010-448-002
Input	120 VAC, 50/60 Hz
Output	1.25 Amp 90 V full wave rectified for one unit and adjustable from 0-90 volts full wave rectified for second unit
Circuit Protection	Fused 1.5 Amp, 250 V
Ambient Temperature	-20° to 113°F (-29° to 45°C)
Maximum Cycle Rate	Limited by the clutch or brake and will vary with application.
Mounting	Mounting centers 5-1/2" wide, 3" high. Knockouts for 1/2" conduit
External Switches (User furnished)	Double pole, double throw maintained contact. Minimum contact rating: 10 Amp, 28 VDC resistive or 10 Amp, 120 VAC inductive. Contact ratings given will operate all Warner Electric brake and clutch units. However, switches with ratings less than those given may be used with fractional horsepower units provided the rating is equal to or greater than the coil current.

All dimensions nominal unless otherwise specified.

### Connection Diagrams

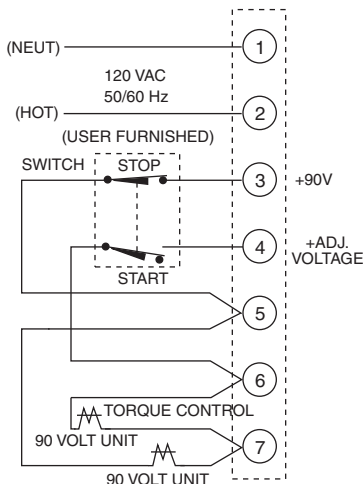

Normal Clutch/Brake Operation  
(One unit on at a time)

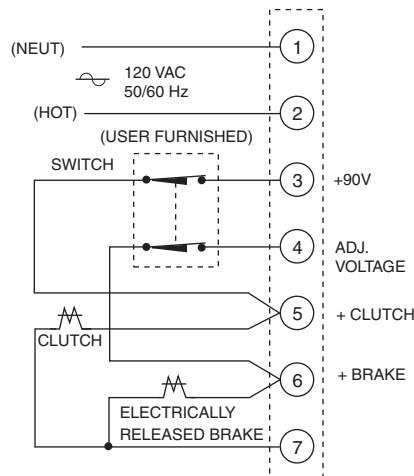

Clutch/Electrically Released Brake Operation  
(Both units on at a time)

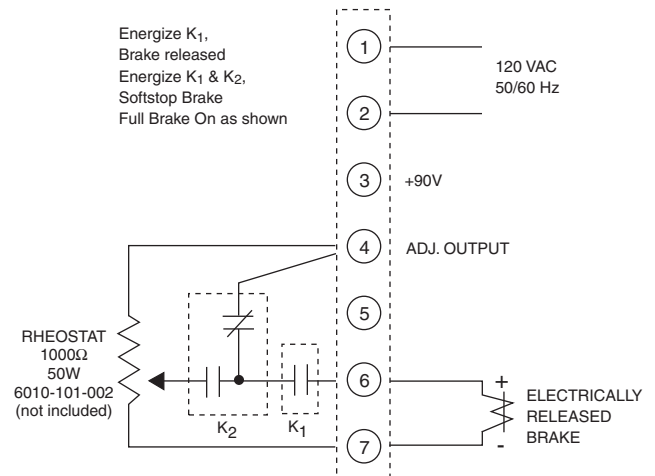

Soft Stop for  
Electrically Released Brake



The DC voltage required to release the Warner Electric ER-1225 Brake is supplied by the MCS-805-1 or MCS-805-2 Power Supply. The correct brake release voltage—approximately 35-75 volts DC—is set by adjusting the power supply at the time of brake installation. Temperature compensating circuits provide proper operation over the entire operating range of 0°F to 150°F. Switching may be provided on either the AC or DC side of the power supply. The MCS-805-1 may be mounted on its back panel or on 1/2" conduit. The MCS-805-2 has a torque adjustment capability for soft stop applications. The MCS-805-2 requires two switching circuits when used for those applications requiring soft engagement.

## Specifications

	MCS-805-1	MCS-805-2
Part No.	6090-448-006	6090-448-007
Input	115/230 VAC, 50/60 Hz ±10%	115/230 VAC, 50/60 Hz ±10%
Output	0.4 Amp, 35/75 VDC	0.4 Amp, 35/75 VDC
Ambient Temperature	-20° to 150°F (-29° to 65°C)	-20° to 150°F (-29° to 65°C)
Maximum Cycle Rate	Limited by the clutch or brake and will vary with application. Consult factory for specifics.	
External Switches (User furnished)	For DC switching: single pole, single throw. Minimum contact rating 1 amp, 120 volts DC resistive. For AC switching: single pole, single throw. Minimum contact rating 1 amp, 120 volts AC.	
Circuit Protection	.75 Amp 250V Slow Blow 3 AG	



## Dimensions

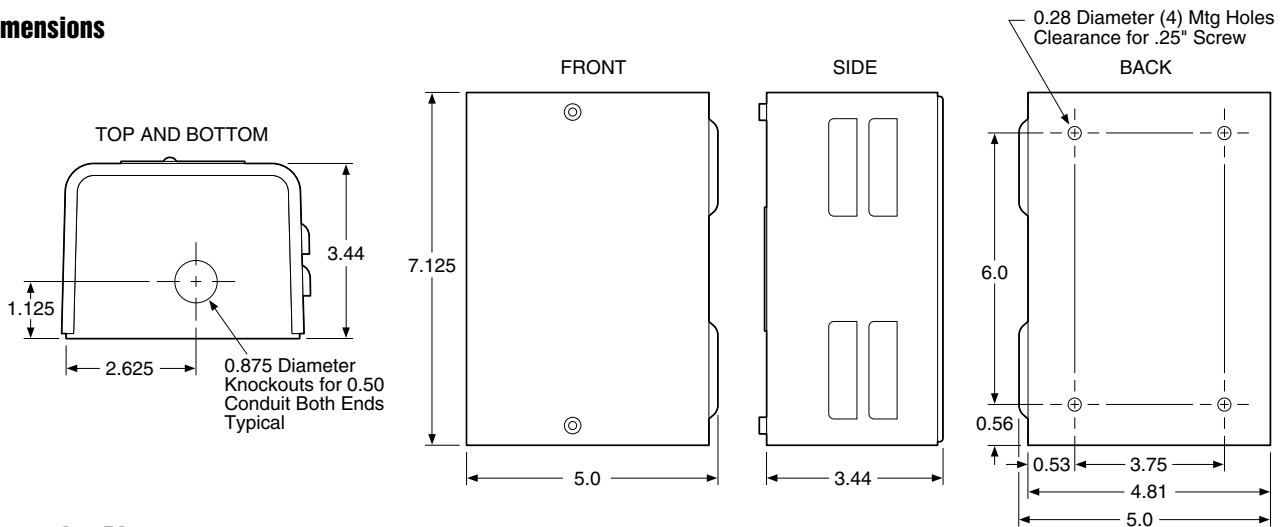

## Connection Diagram

Connect the MCS-805-1 or MCS-805-2 Power Supply per the following diagram and instructions:

### MCS 805-1

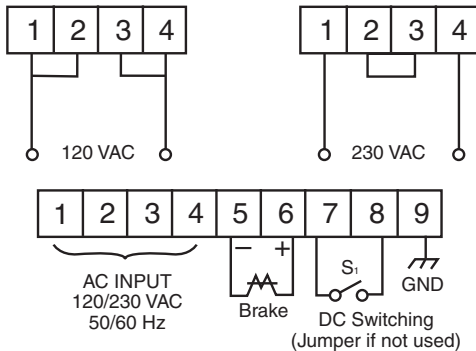

### MCS 805-2

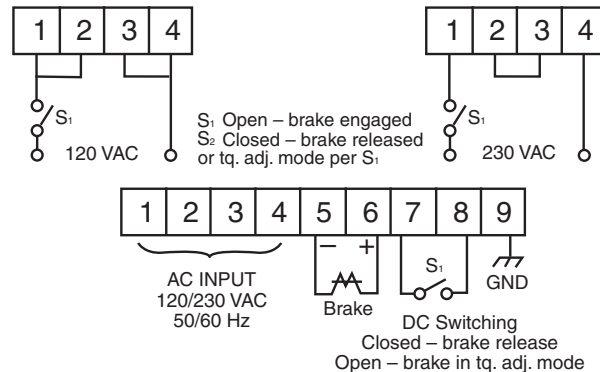



For AC switching, switch may be in series with input supply.  
For DC switching, use terminals 7 and 8 as shown.

## Single or Dual Channel Adjustable Torque Control

The CBC-200 and CBC-300 Controls provide single/dual torque control when connected to any of Warner Electric's 90 volt clutches and brakes.

### Common features

-  and 
- Current monitored output maintains consistent torque regardless of variation in coil temperature.
- Switch selection tunes control to exactly match power requirements and operating characteristics of each clutch or brake.
- Individual torque adjust allows preset maximum torque tailored to application requirements.
- Short circuit protection, line to line.
- Torque limiting protects machine components from damage.
- Can be used with electrically released brakes.



### CBC-200 Dual channel/Single channel torque adjust

The CBC-200 is a dual channel control with one adjustable current and one fixed voltage.

### CBC-300 Dual channel/Dual channel torque adjust

The CBC-300 has two adjustable current channels.

### Specifications

	CBC-200	CBC-300
Part No.	6011-448-001	6021-448-001
Input Power	120 VAC +10% -15%, 50/60 Hz, single phase, 215 VA max.	
Output	Pulse-width modulated full wave rectified D.C. Constant current, switch selectable ranges, 0-90 volt	
Ambient Temperature	+32°F to +113°F (0°C to 45°C) with plastic cover installed +32°F to +150°F (0°C to 66°C) with plastic cover removed	
Circuit Protection	Internal line to line short circuit protection Optional customer supplied fusing on A.C. line, 1.5 Amps, 250 VAC. Fast-acting fuse recommended	
Current Adjust (via front panel potentiometers)	Single adjustable channel	Dual adjustable channels
Status indicators	"POWER"—green LED indicates A.C. power is applied to the control. "SHORT"—red LED indicates a short circuit condition exists on one or both outputs.	
Internal Adjustments	Set DIP switches SW1 and SW2 to suit the current draw of the connected clutch/brake coil: Switch Range Max Current Draw (mA)	
		1      2      3      4      5
		60    175    245    305    533
External Switching	Mechanical or electromechanical—customer supplied: 1 Amp, 125 V minimum rating Solid-state, NPN isolated transistor—customer supplied: 2 Amp, J250 V minimum rating. Maximum off state leakage current <1 mA	

### Dimensions

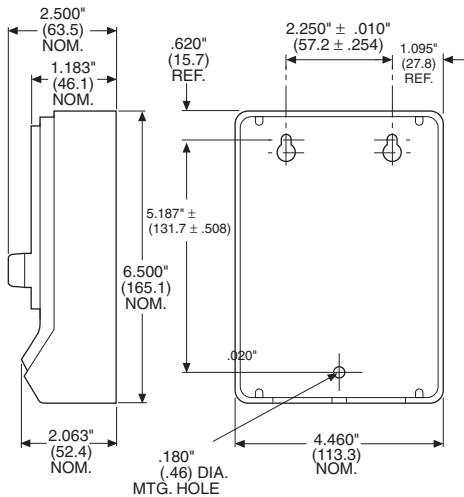

### Connection Diagram

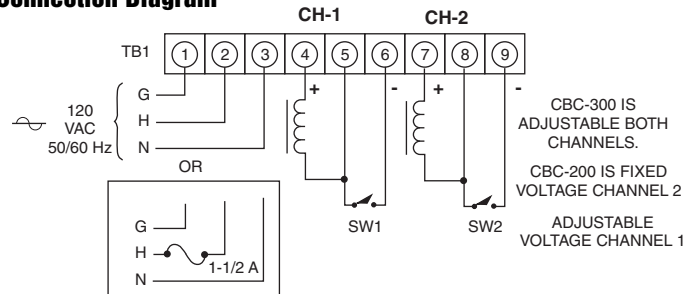

## Panel Mounted

### CBC-500 series Dual torque adjustable power supplies

The CBC-500 series is a dual channel adjustable voltage control with optically isolated input switching for 24 and 90 volt electric clutches and brakes. These controls can be set up to energize the two outputs alternately (single) or simultaneously (dual). Refer to the Appendix page 282 for additional setup and switching information.



- Dual adjustable channels
- Optically isolated input switching
- Single or dual channel operation
- Auxiliary 12V supply
- Can be used with electrically released brakes

### Enclosure (Optional)



- Lift off hinge
- Quick-release latches
- Conforms to NEMA Type 13
- European Standard IEC 529, IP65

<b>Part No.</b>	<b>6042-101-004</b>
Size	8"H x 6"W x 4"D (203.2 x 152.4 x 101.6 mm)

### Dimensions

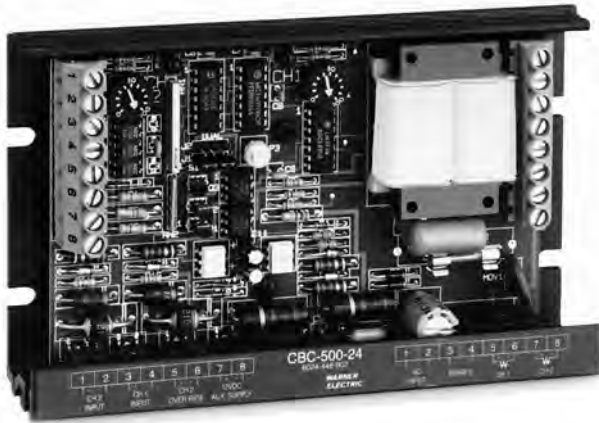
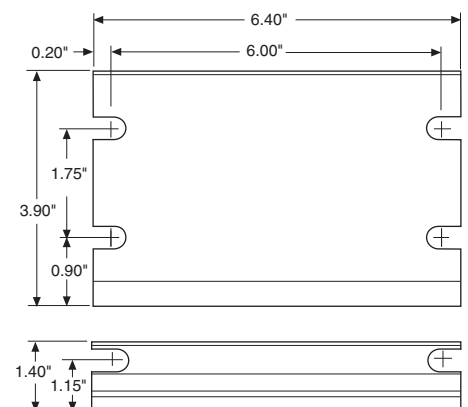

### Specifications

	<b>CBC-500-90</b>	<b>CBC-500-24</b>
Part No.	6024-448-003	6024-448-002
Input Voltage	120 VAC	24-30 VAC
Output Voltage	0-90 VDC	0-24 VDC
Output Current	1 Amp/Channel 2 Amps Total	5 Amps/Channel 5 Amps Total
Auxiliary Supply	12 VDC 250 mA	12 VDC 250 mA
Circuit Protection	Fused 2.5 Amp, 250 V Fast-blo	Fused 6.3 Amp, 250 V Fast-blo
Ambient Temperature	+32° to 122°F (0° to 50°C)	
Status Indicators	Red LED indicates channel is energized.	
Adjustments	Two potentiometers for voltage adjustment of channel 1 and channel 2 output from 0 to full rated voltage. Frequency adjustment from 60 to 400 Hz to reduce clutch/brake "Hum" associated with machine frequencies. Jumper for single or dual operation. See appendix on page 282 for explanation.	
Inputs:	3 Optically coupled, 10-30 VDC, 3-9 mA for Channel 1, Channel 2 and Channel 2 override (applies full voltage to channel 1 output)	

### Connection Diagram

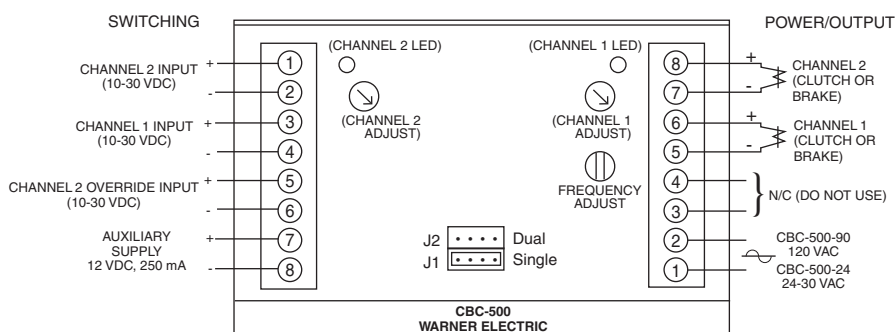

All dimensions nominal unless otherwise specified.

## Panel Mounted

### CBC-550 series Dual adjustable with power transformer

The CBC-550 series is a dual channel adjustable voltage control with optically coupled switching for 24 and 90 volt electric clutches and brakes. These controls can be set up to energize the two outputs alternately (single) or simultaneously (dual). Refer to the Appendix page 282 for additional setup and switching information.

The CBC-550 series has a power transformer which will operate with a 120, 220, 240, 380, or 480 VAC input.

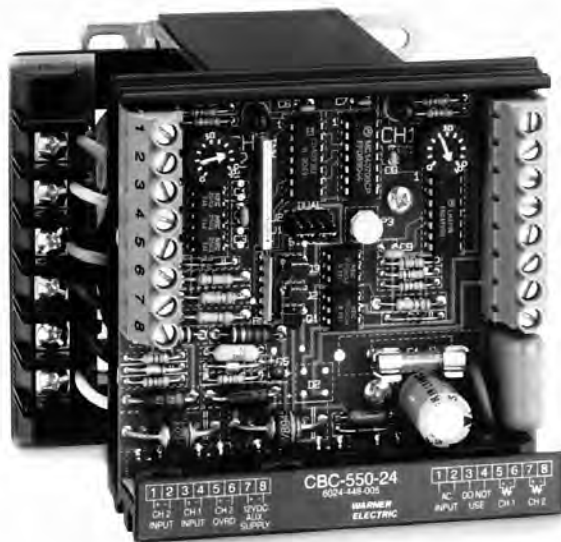

- Dual adjustable channels
- Optically isolated input switching
- Single or dual channel operation
- Can be used with electrically released brakes

### Specifications

	CBC-550-90	CBC-550-24
Part No.	6024-448-006	6024-448-005
Input Voltage	120/220/240/380/480 VAC	
Output Voltage	0-90 VDC	0-24 VDC
Output Current	1 Amp/Channel 1.2 Amps Total	4 Amps/Channel 4 Amps Total
Auxiliary Supply	12 VDC 250 mA	12 VDC 250 mA
Circuit Protection	Fused 1.5 Amp, 250 V fast-blo	Fused 5 Amp, 250 V fast-blo
Ambient Temperature	+32° to 122°F (0° to 50°C)	
Status Indicators	Red LED indicates channel is energized.	
Adjustments	Two potentiometers for voltage adjustment of channel 1 and channel 2 output from 0 to full rated voltage. Frequency adjustment from 60 to 400 Hz to reduce clutch/brake "Hum" associated with machine frequencies. Jumper for single or dual operation. See appendix on page 282 for explanation.	
Inputs	3 Optically coupled, 10-30 VDC, 3-9 mA for Channel 1, Channel 2 and Channel 2 override (applies full voltage to channel 1 output)	

### Enclosure (Optional)



- Lift off hinge
- Quick-release latches
- Conforms to NEMA Type 13
- European Standard IEC 529, IP65

Part No.	6006-101-007
Size	6"H x 6"W x 6"D (152.4 x 152.4 x 152.4 mm)

### Dimensions

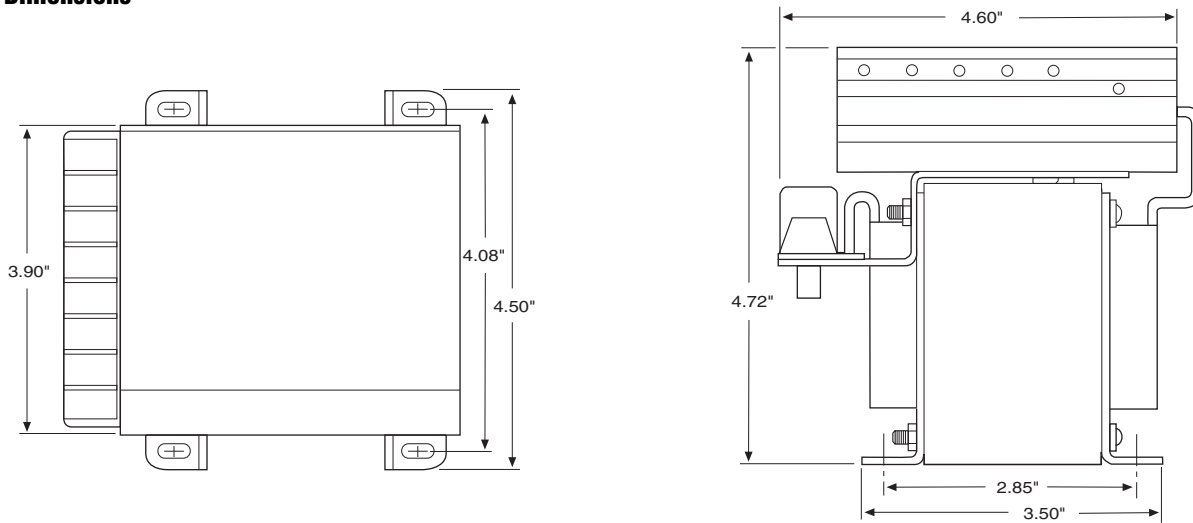

### Connection Diagram

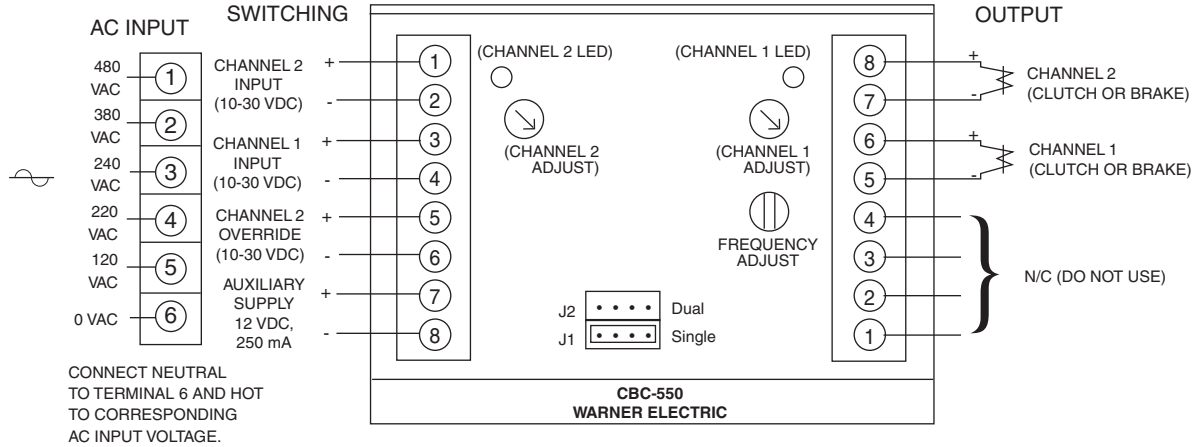

All dimensions nominal unless otherwise specified.

## Panel Mounted

### CBC-1825R series

The CBC-1825R is designed to provide consistent and repeatable acceleration and deceleration when used with Warner Electric 90 VDC clutches and brakes. Current to each channel is introduced along an adjustable time ramp and monitored continuously. Adjustments include initial pull-in pulse, hold level, maximum torque, and ramp time. LEDs are provided on the circuit board to indicate power is applied to the clutch or brake unit.

**Note:** It is recommended that the auto-gap springs be removed from the clutch and brake for successful accel-decel application.



### Connection Diagram

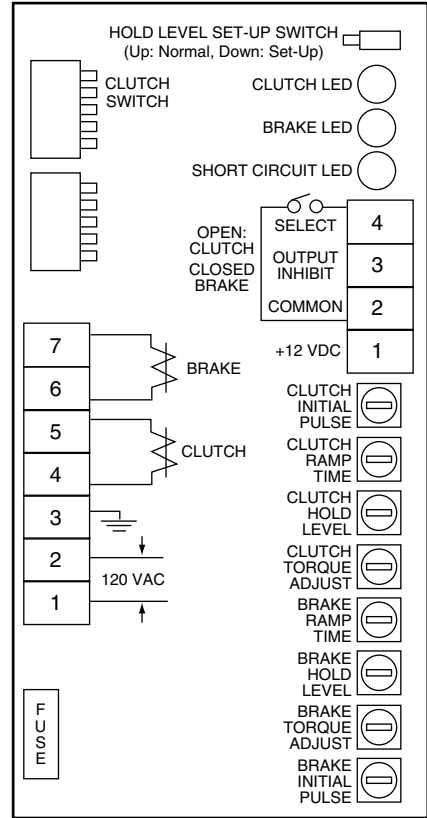

FRONT VIEW

### Specifications

CBC-1825R	
Part No.	1825-448-001
Input Voltage	120 VAC, 50/60 Hz, 100 VA maximum
Output Current	Current driven PWM, compatible with 90 VDC clutch/brake (switch selectable current output)
Auxiliary Supply	12 VDC 250 mA
Circuit Protection	Input Fused 1.5 Amp, 250 V fast-blo clutch and brake outputs are short circuit protected
Status Indicators	Clutch and brake LEDs indicate output is energized Short circuit LED indicates a fault
Ambient Temperature	0° to 122°F (-18° to 50°C)
Switching	Contact rating: 15 mA @ 15 V, open collector NPN 2mA maximum allowable leakage current and 2 V maximum saturation voltage

### Dimensions

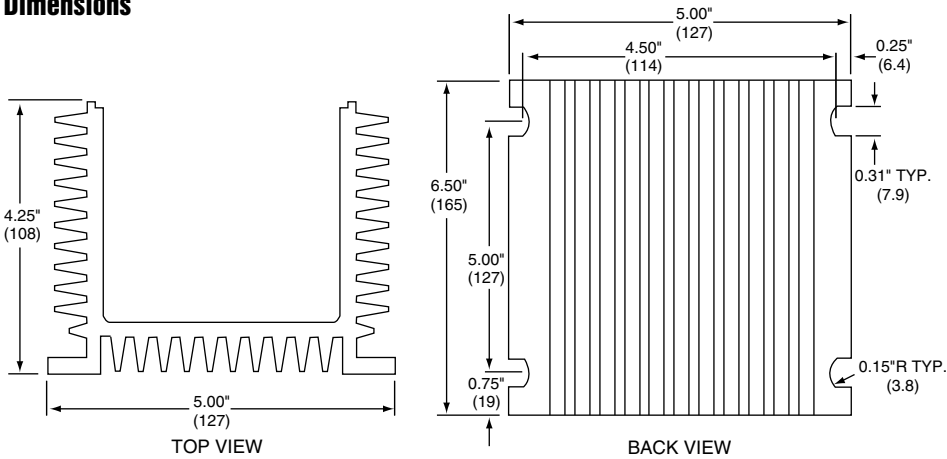

### Set-up

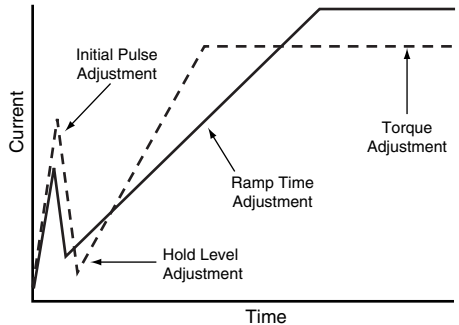

All dimensions nominal unless otherwise specified.

### CBC-700 series

Simple, compact, high performance OEX control for either 90 or 24 VDC clutches and brakes. OEX spike duration and anti-overlap times delay are adjustable. Two optically isolated inputs.



- High performance
- Switch selectable OEX duration
- Force decay suppression with adjustable anti-overlap time delay
- Compact, flexible mounting
- Models for 24 or 90 volt clutches and brakes
- Cycle rate limited by clutch/brake

### Enclosure (Optional)



- Lift off hinge
- Quick-release latches
- Conforms to NEMA Type 13
- European Standard IEC 529, IP65

<b>Part No.</b>	<b>6042-101-004</b>
Size	8"H x 6"W x 4"D (203.2 x 152.4 x 101.6 mm)



### Specifications

	CBC-700-90	CBC-700-24
Part No.	6042-448-003	6042-448-002
Input	120 VAC, 50/60 Hz	24-28 VAC, 50/60 Hz
Output Voltages		
Steady State	90 VDC	24 VDC
Overexcitation	340 VDC	105 VDC
Output Current (Per channel alternately)	.5 Amps	3.5 Amps
OEX Pulse Duration	Adjustable through logic board dip switches (see service manual)	
Inputs	Two-optically isolated (10-30 VDC)	
Ambient Temperature Range	0°F to 140°F (-18°C to +60°C)	
Maximum Off State Leakage	<2 mA (inputs)	
Circuit Protection	2.5A Slo-Blo (5 x 20 mm)	5A Slo-Blo (5 x 20 mm)
Auxiliary Supply	12 VDC, 250 mA maximum	

### Connection Diagram

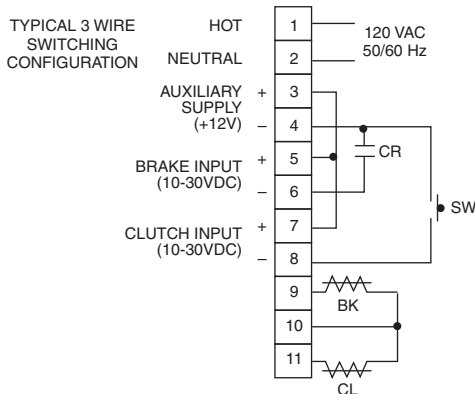

**NOTE:** CR, SW user furnished switch options for use with control.  
CR normally open relay contact  
SW normally open push button switch

### Dimensions

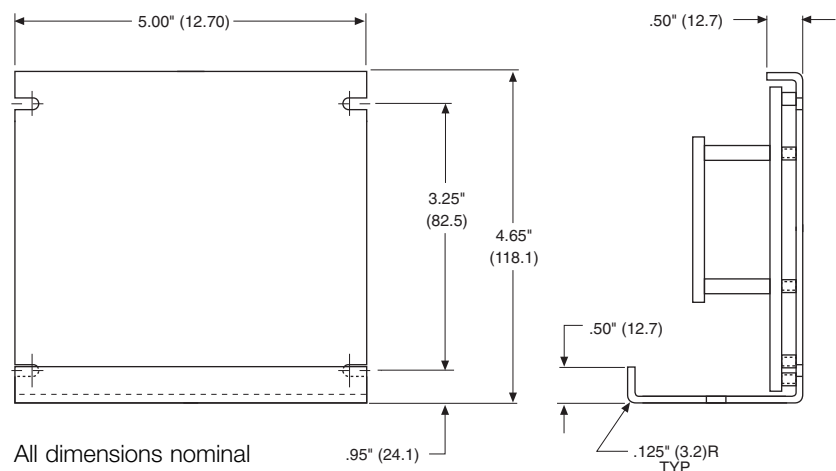

All dimensions nominal unless otherwise specified.

**Rapid Acceleration/Deceleration**

**CBC-750 series  
Dual channel, current based OEX with  
switching logic**

Warner Electric's CBC-750 series of Constant Current Overexcitation Clutch/Brake Controls are solid-state electronic controls designed to increase the cycle rate capabilities and accuracies of electromagnetic clutches and brakes. The controls accomplish this by sending a momentary high voltage overexcitation spike to the clutch and/or brake magnetic coil to build a high density magnetic flux field almost instantaneously. By using overexcitation, the response time is reduced as dramatically as performance is increased. For example, the current build up time of a 5 inch, 6 volt magnet is reduced from 84 milliseconds to 2 milliseconds.

The CBC-750 user selects either 120, 220 or 240 VAC operation at the time of installation. Models for 6 volt, 24 volt, or 90 volt clutches and brakes are available.



Shown with optional cover, part number 6041-101-004

LED indicators on the faceplate of each control tell the user the status of input signals, output activation and any auxiliary inputs. A reset switch resets the output should a short be detected. Remote torque adjust potentiometer inputs are also provided. Appropriate current range for each size clutch or brake is selected by a dip switch. Constant current for each level is assured by the control's

design.

- Maintains torque at preset levels regardless of temperature variations
- Automatically controls OEX pulse duration for optimum response without overheating coils
- Automatically prevents clutch and brake "overlap"
- Configurable as an analog follower control through remote top input

**CE**

- High performance OEX control
- Constant current output capability
- Models for 6, 24, and 90 V clutches and brakes
- Outputs short circuit protected.
- AC/DC optically isolated inputs
- Transformer isolation  
Remote torque potentiometer capability
- Input/Output inhibit functions
- Switch selectable OEX function
- Automatic CH1/CH2 anit-overlap feature
- Heavy duty suppression circuits
- Selectable output current ranges
- Remote status indicators inputs and outputs

**Specifications**

	<b>CBC-750-6</b>	<b>CBC-750-24</b>	<b>CBC-750-90</b>
Part No.	6041-448-001	6041-448-002	6041-448-003
Input Power	120/220/240 VAC, ±10%, 50/60 Hz, 350 VA (switch selectable)		
Control Inputs	Opto-isolated 10-30 VDC @ 10-35 mA nominal sinking or sourcing, or 24 VAC (50/60Hz) @ 22 mA nominal, or 120 VAC (50/60 Hz) @ 20 mA nominal		
Clutch/brake Output			
Steady State Output			
Current controlled	.910 to 4.34 A max.	.227 to 1.175 A max.	.060-.310 A max.
Current Rise Time	Dependent on clutch/brake size		
Current Fall Time	Depending on clutch/brake size		
Overexcitation Voltage	75 VDC nom.	240 VDC nom.	450 VDC nom.
Overexcitation Time	Automatic adjustment by control feedback		
Anti-overlap Time	Automatic adjustment by control feedback		
Power Supply Output	12 VDC, ±0.6 VDC, 250 mA max.		
Auxiliary Indicator Outputs	Opto-isolated NPN transistors 24 VDC maximum, 20 mA max., reverse polarity protected		
Circuit Protection	Internal short circuit protection on each output channel.		
Fusing			
AC Input Line	2 Amp, 250 V Slo-Blo		
OEX Supply	10 Amp, 32 V Slo-Blo	5 Amp, 250 V Slo-Blo	1 Amp, 250 V Slo-Blo



Seven optically isolated inputs accept 10-30V A.C./D.C. (TB2) or 120 VAC (TB3), configured through set-up switches

1. Channel 2 Input
2. Channel 2 Input Inhibit (disregards channel 2 input signal)
3. Auxiliary Input
4. Channel 1 Input
5. Channel 1 Input Inhibit (disregards channel 1 input signal)
6. Output Inhibit (deactivates both output channels)
7. Channel 2 Override (applies full voltage to channel 1 output)

### Connection Diagram

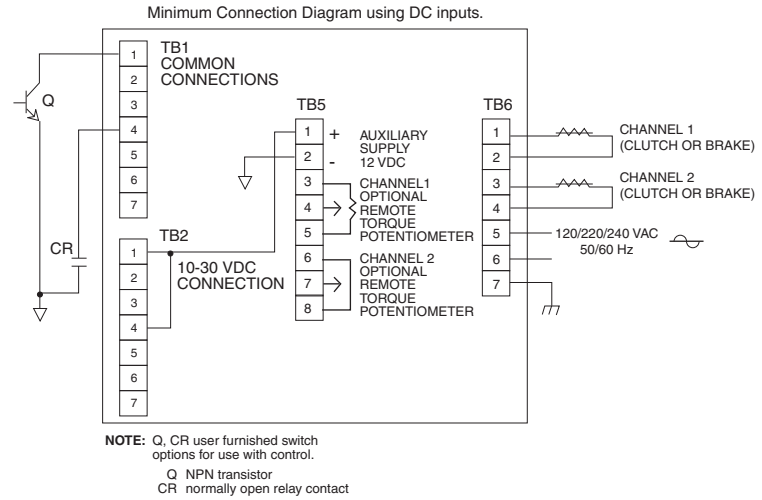

### Dimensions

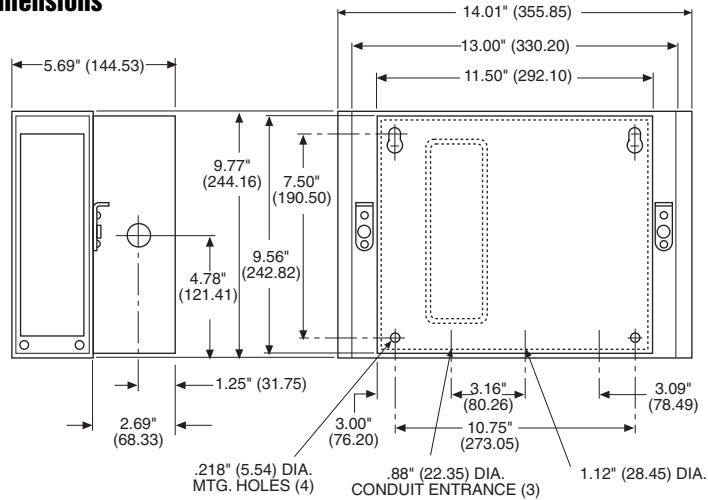

### Setup Switches

SW1: AC Voltage selection switch on terminal board inside control unit

### Max. Current Output

(SW7 & SW8 settings)

Nominal Voltage	1	2	3	4	5
6	0.910	2.35	3.183	3.760	4.340
24	0.227	0.641	0.881	0.940	1.175
90	0.060	0.176	0.256	0.282	0.310

#### SW8

Channel 2 current range selector (settings in diagram below)

#### SW7

Channel 1 current range selector (settings in diagram below)

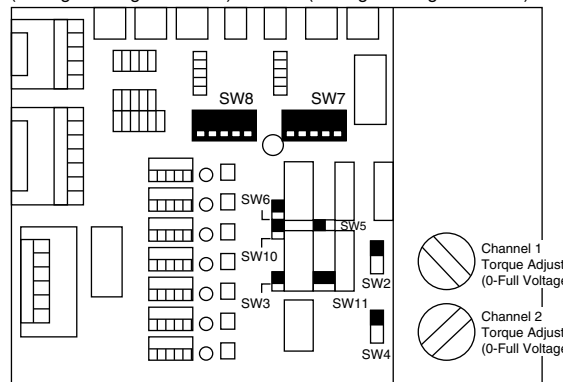

All switches are in the down (⌵) position from factory

#### SW6

Channel 2 OEX enable (⌵) / disable (⌶)

#### SW5

Channel 1 OEX enable (⌵) / disable (⌶)

#### SW10

Channel 1 input invert (⌵) / (⌶)

#### SW2

Channel 1 local (⌵) or remote (⌶) torque adjust

#### SW3

Level/pulse selector level (⌵) pulse (⌶)

#### SW4

Channel 2 local (⌵) or remote (⌶) torque adjust

#### SW11

Auxiliary input selector Channel 1 (⌵) Channel 2 (⌶)

## System Accuracy

### CBC-1000

#### Position-loop control with error correction compensation

Warner Electric's CBC-1000 is a closed-loop positioning control with error compensation designed for industrial clutch/brake applications. The position loop is closed through encoder feedback which generates pulses proportional to load motion. The CBC-1000 uses this feedback to determine the optimum brake actuation point. The control can be programmed to operate in one of two distinct modes: absolute or incremental. The CBC-1000 includes eight solid state control outputs, a batch counter and a serial communications interface.

The CBC-1000 system consists of four key elements: the CBC-1000, a clutch/brake, a clutch/brake control, and an encoder. Nearly any electric clutch/brake size and configuration can be used. The clutch/brake control should have solid-state compatibility. Simple on-off, soft start/stop, and overexcitation controls may all be utilized based on the desired velocity profile.

### Accessories

Description	Part Number
Encoder Cable (Accessory)	6060-101-001
Encoder Cable (Accessory) 7 Pin for marker	6060-101-002
100 PPR Encoder w/10' cable	6060-101-010
250 PPR Encoder w/10' cable	6060-101-025
600 PPR Encoder w/10' cable	6060-101-060
600 PPR w/marker & 10' cable	6060-101-061
1200 PPR Encoder w/10' cable	6060-101-120
2500 PPR Encoder w/10' cable	6060-101-250
5000 PPR Encoder w/10' cable	6060-101-500

(PPR—Pulse Per Revolution)

### Serial Interface Module



Performs the necessary voltage level conversions to interface the RS-422A/485 output of the CBC-1000 to RS-232C equipment.

Part Number: 6060-101-232



### Specifications

Part No.	6060-448-001
Input Power	100 to 130 VAC, 50/60 Hz, 20VA (200 to 260 VAC selectable)
Auxiliary Supply	12 VDC @ 175 mA Used for powering encoder, etc.
Main Counter	
Range	6 Decades
Reset Input	External and front panel
Count Rate	(20 kHz external input frequency)
Batch Counter	
Range	6 Decades
Reset	Through front panel only
Signal A and B Inputs	
Input Frequency	D.C., 20 kHz quadrature max.
Input High Level	3.25 VDC min.
Input Low Level	1.75 VDC max.
Control Inputs	
Input Frequency	D.C. to 20 Hz max. each input
Input Type	Single ended, current sinking
Input Logic	Both Edge and Level sensitive as defined by input use
Input High Level	10 VDC min. to 20 VDC max.
Input Low Level	0 VDC min. to 2 VDC max.
Input Current	2.5 mA steady state
Display	
Decades	7 Decade, 0.6" red LED
Decimal Point	User programmable Range: xxx.xxx to xxxxxx
Program Security	Program LOCK of lines 1 - 33
Control Outputs	
Type	8 Solid State 100 mA sink max., 24 VDC max.
Serial Interface	
Type	RS-422A/485 compatible
Baud Rate	Selectable: 300, 600, 1200, 2400
Parity	Selectable: None, Odd, Even
Data	ASCII
Diagnostics	Nine Self-Test Diagnostics
Mechanical	
Enclosure	Aluminum extrusion with molded VALOX bezel.
Weight	2.5 lbs.
Environmental	
Operating Temp.	0° to +50°C (32° to 122°F)
Storage Temp.	-18° to 85°C (0° to 186°F)
Ambient Humidity	90% and noncondensing

### 1. Select the proper clutch/brake

- Determine torque and inertia requirements
- Calculate heat dissipation for required cycle rate
- For best accuracy, mount clutch/brake directly on nip or drive shaft; avoid backlash

### 2. Select quadrature encoder

- Select encoder PPR for desired system resolution (i.e. inches/pulse, degrees/pulse, etc.)
- Determine input frequency; do not exceed 20,000 pulses/sec.
- Mount encoder directly to nip or drive shaft for best accuracy

### 3. Select clutch/brake power supply

- Use CBC-700 overexcitation control for best accuracy
- Use CBC-500/550 for soft starting and/or stopping
- Brake autogap may have to be removed for best accuracy

### 4. Plan system logic (switching requirements)

- Use absolute mode for indexing applications such as conveyors and turntables or cutoff applications where close registration is required
- Use incremental mode for cutoff applications
- Determine switching and relays required for machine operation

### 5. Select serial interface module if applicable.

### Timing Diagram

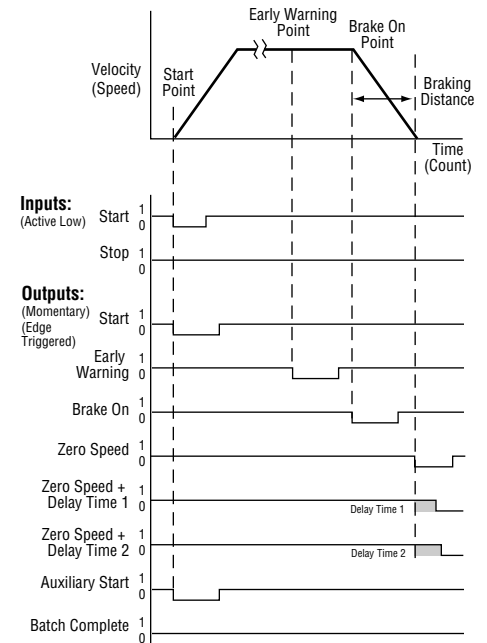

### Operation

Successful operation will require knowledge of the following definitions and their relationships to the timing diagram.

### Function Key Definitions

Count	<b>1</b> COUNT	The actual move distance, in pulses or scaled into engineering units (inches, feet, rotations, degrees, etc.) displayed dynamically.
Move Present	<b>2</b> MOV PST	The desired move distance in pulses or scaled into engineering units. This is the value the operator enters to select a new move distance.
Early Warning	<b>3</b> E.W.	A distance prior to Move Present at which the early warning output is activated. Expressed as pulses or engineering units, this output can be used to accomplish a soft brake (slow down), energize valves, etc.
Batch	<b>6</b> BATCH	A cumulative batch counter that can be dynamically displayed to show the number of operations, cycles, etc. When this counter reaches the value programmed by the Batch Preset (key 7) the Batch Complete Output is activated. The batch counter can be manually or automatically reset.
Batch Preset	<b>7</b> BCH PST	A programmable batch counter activates the batch complete output when the value programmed has been reached by the batch (key 6)
Braking Distance	<b>8</b> BRK DIS	The actual distance required to stop. This value is dynamically updated to determine the brake actuation point. Factory default is 25 pulses or engineering units which is only used for the first cycle after power-up. After the first cycle the CBC-1000 will tune to the particular brake being utilized. The amount of cycles needed for tuning depends on how far the true braking distance value is from the default of 25.

# Appendix

## CBC-400/450/500/550 Single vs Dual Operation

The CBC 400 and 500 series controls allow operation in either a single or dual mode. The mode of operation is determined via the position of a jumper on the main control board.

The controls are shipped with the jumper in the J1 or single mode position. A variety of output logic can be accomplished via the single/dual jumper position and whether the control is wired to one input switching device (2-wire mode) or two input switching devices (3-wire mode). The following diagrams show how each channel (output) of the control can be either alternately or simultaneously energized.

### 2-wire Switching Option

#### Control's switching terminal block

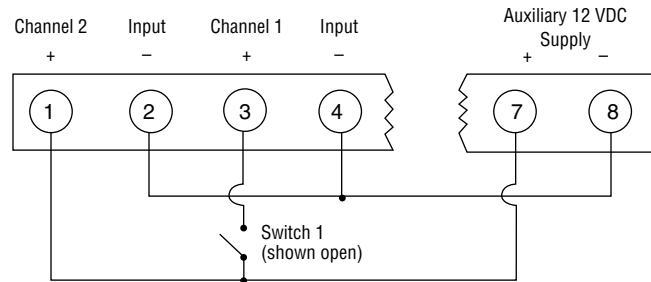

Jumper Mode	Switch 1	Channel 1	Channel 2
J1-Single	Open	Off	Powered
	Closed	Powered	Off
J2-Dual	Open	Powered	Powered
	Closed	Off	Off

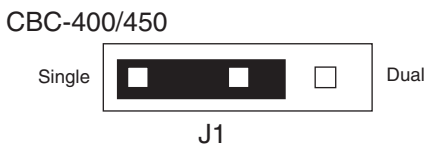
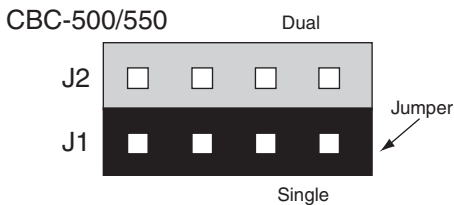

### 3-wire Switching Option

#### Control's switching terminal block

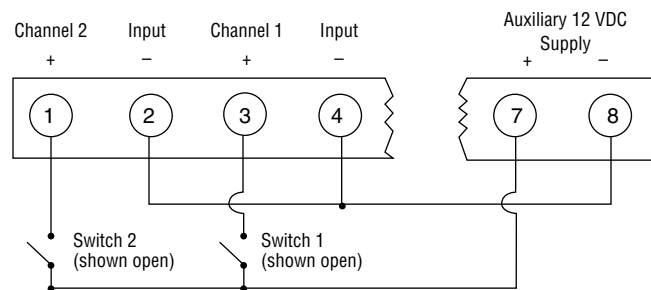

Jumper Mode	Switch 1	Switch 2	Channel 1	Channel 2
J1-Single	Closed	Open	Latched On	Off
	Open	Closed	Off	Latched On
J2-Dual	Closed	Open	Off	Off
	Open	Closed	Latched On	Latched On

## 1. What transformers can be used with controls requiring 24-30 VAC input?

Manufacturer	Part Number	Primary	Secondary
Abbott	6B 12-160	115 VAC	24V @ 6 amps
Quality	6-K-119VBR	115/230 VAC	24V @ 8 amps
Signal	24-6	115 VAC	24V @ 6 amps
Signal	DP24-6	115/230 VAC	24V @ 6 amps
Triad	F-260-U	115 VAC	24V @ 6 amps

## 2. When a single clutch or brake is used with a CBC-200 and no switch is used, a jumper wire is required across terminals 5 & 6 to get output at terminals 4 & 5.

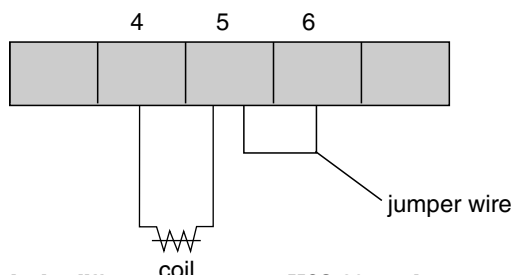

## 3. What is the difference between a MCS-801 and a CBC-801-1 or between a MCS-103 and a MCS-103-1?

There is no performance difference between the MCS-103 and MCS-103-1. There is no performance difference between the MCS-801 and CBC-801-1. The CBC-801-1 is roughly 1/4" shorter than the MCS-801. The units wire and work exactly the same.

## 4. Which power supplies can be used with the SF 1525HT and SFC 1525HT coil?

The SF and SFC 1525 High Torque clutch coils require .794 amps of current to provide full rated torque. The following power supplies and controls will provide the needed power.

CBC-100	.8 amps	CBC-450	1 amp
CBC-150	.8 amps	MCS-103-1	1.25 amps
CBC-801	1.25 amps	CBC-500	1 amp
CBC-400	1 amp	CBC-550	1 amp

## 5. Can I use a CBC-160 with a variable frequency drive and AC motor?

No. As the voltage to the drive is varied, the output to the electrically released brake would also vary. This would cause the brake to re-engage when it should be released.

## 6. Which power supplies offer a 12 VDC power source that could be used to power auxiliary switch inputs such as inductive or photoelectric sensors?

CBC-400, CBC-450, CBC-500,  
CBC-550, CBC-700, CBC-750

## 7. Is the CBC-1000 a stand-alone control?

No. The CBC-1000 provides closed loop feedback for a clutch/brake system. A common system will consist of four components:

- a Warner Electric brake and clutch
- a Warner Electric power supply
- an Encoder
- a CBC-1000 position control

The application criteria will determine which clutch/brake and which control will be appropriate selections.

## 8. Which of the controls would allow for the independent operation of two clutches or two brakes?

Four controls allow for completely independent operation of two clutches or brakes. That is, that a clutch and brake can both be on at once, both off at once, or one on and one off. These controls are:

CBC-801-1 and CBC-801-2, MCS-103-1, CBC-200, CBC-300

The CBC-400/450 and CBC-500/550 allow for operation of both channels on at once, both channels off at once or cycling between channel one and two. However, in the both-on/both-off mode, you cannot also do independent single channel operation.

## 9. Are there any controls that can be used to control the torque of a 90 volt clutch or brake via an analog signal input?

There are two options we offer, a special TCS-200 or a Bronco drive (B169 or B161s) with a signal follower card. These units can be configured to provide a variable torque output for a clutch or brake based on an analog input signal. Consult the factory for the best solution for your specific application needs.

## 10. Which controls can be used with electrically released brakes?

The CBC-160-1 and CBC-160-2 are designed specifically to use with the conduit box of EM and EUM electrically released brake designs. The CBC-160-1 and CBC-160-2 can also be used with ER and FB brake designs.

The MCS-103-1, CBC-200, CBC-300 and CBC-500/550 can all be used with ER, FB as well as UM-FBC, EM and EUM-FBB and EM and EUM-MBFB designs.

The MCS 805-1 and MCS 805-2 are for use only with the ER 1225 brakes. The ERS series brakes can be used with the CBC-100 or CBC-801 power supplies.

# Ordering Information

---

Model	Part Number	Page
CBC-100-1 .....	6003-448-101 .....	264
CBC-100-2 .....	6003-448-103 .....	264
MCS-103-1 .....	6010-448-002 .....	270
CBC-150-1 .....	6004-448-001 .....	264
CBC-150-2 .....	6004-448-002 .....	264
CBC-160-1 .....	6013-448-001 .....	265
CBC-160-2 .....	6013-448-002 .....	265
MCS-153-1 .....	6012-448-001 .....	271
CBC-200 .....	6011-448-002 .....	272
CBC-300 .....	6021-448-001 .....	272
CBC-400-24 .....	6006-448-002 .....	268
CBC-400-90 .....	6006-448-003 .....	268
CBC-450-24 .....	6006-448-005 .....	269
CBC-450-90 .....	6006-448-006 .....	269
CBC-500-24 .....	6024-448-002 .....	273
CBC-500-90 .....	6024-448-003 .....	273
CBC-550-24 .....	6024-448-005 .....	274
CBC-550-90 .....	6024-448-006 .....	274
CBC-1825R .....	1825-448-001 .....	276
CBC-700-24 .....	6042-448-002 .....	277
CBC-700-90 .....	6042-448-003 .....	277
CBC-700 Enclosure .....	6042-101-004 .....	277
CBC-750-6 .....	6041-448-001 .....	278
CBC-750-24 .....	6041-448-002 .....	278
CBC-750-90 .....	6041-448-003 .....	278
CBC-801-1 .....	6001-448-004 .....	266
CBC-801-2 .....	6001-448-006 .....	266
Octal Socket, Foot Mount .....	6001-101-001 .....	266
Octal Socket, DIN Rail Mount.....	6001-101-002 .....	266
CBC-802-2 .....	6002-448-001 .....	267
CBC-1000 .....	6060-448-001 .....	280
Serial Interface Module.....	6060-101-232 .....	280
Encoder Cable (Accessory) .....	6060-101-001 .....	280
Encoder Cable (Accessory) 7 Pin for marker .....	6060-101-002 .....	280
Encoders: 100 PPR .....	6060-101-010 .....	280
250 PPR .....	6060-101-025 .....	280
600 PPR .....	6060-101-060 .....	280
600 PPR w/ marker .....	6060-101-061 .....	280
1200 PPR .....	6060-101-120 .....	280
2500 PPR .....	6060-101-250 .....	280
5000 PPR .....	6060-101-500 .....	280
Optional Enclosure: CBC-400, CBC-500, CBC-700 .....	6042-101-004 .....	268
Optional Enclosure CBC-450, CBC-550 .....	6006-101-007 .....	269

# The power of one, the strength of many.

## *Other product solutions from* **Altra Industrial Motion**

Our comprehensive product offering is comprised of nine major categories including electromagnetic clutches and brakes, heavy duty clutches and brakes, overrunning clutches, gearing, engineered couplings, engineered bearing assemblies, linear products and belted drives. With thousands of product solutions available, Altra provides true single source convenience while meeting specific customer requirements. Many major OEM's and end users prefer Altra products as their No.1 choice for performance and reliability.

[www.altramotion.com](http://www.altramotion.com)



### **Electromagnetic Clutches and Brakes**

Warner Electric  
Inertia Dynamics  
Matrix International



### **Heavy Duty Clutches and Brakes**

Wichita Clutch  
Twiflex Limited  
Industrial Clutch



### **Overrunning Clutches**

Formsprag Clutch  
Marland Clutch  
Stieber Clutch



### **Engineered Couplings and Universal Joints**

TB Wood's  
Ameridrives Couplings  
Ameridrives Power Transmission  
Bibby Transmissions



### **Belted Drives and Sheaves**

TB Wood's



### **Gearing**

Boston Gear  
Nuttall Gear  
Delroyd Worm Gear



### **Linear Products**

Warner Linear



### **Engineered Bearing Assemblies**

Kilian Manufacturing



### **Precision Couplings and Air Motors**

Huco Dynatork

All Customer Service phone numbers shown in bold

## Electromagnetic Clutches and Brakes

### Warner Electric

*Electromagnetic Clutches and Brakes*

New Hartford, CT - USA  
**1-800-825-6544**

*For application assistance:*  
1-800-825-9050

St Barthelemy d'Anjou, France  
**+33 (0) 2 41 21 24 24**

*Precision Electric Coils and Electromagnetic Clutches and Brakes*

Columbia City, IN - USA  
**1-260-244-6183**

### Matrix International

*Electromagnetic Clutches and Brakes, Pressure Operated Clutches and Brakes*

Brechin, Scotland  
**+44 (0) 1356 602000**

New Hartford, CT - USA  
**1-800-825-6544**

### Inertia Dynamics

*Spring Set Brakes; Power On and Wrap Spring Clutch/Brakes*

New Hartford, CT - USA  
**1-800-800-6445**

## Linear Products

### Warner Linear

*Linear Actuators*

Belvidere, IL - USA  
**1-800-825-6544**

*For application assistance:*  
1-800-825-9050

St Barthelemy d'Anjou, France  
**+33 (0) 2 41 21 24 24**

## Couplings

### Ameridrives Couplings

*Mill Spindles, Ameriflex, Ameridisc*

Erie, PA - USA  
**1-814-480-5000**

*Gear Couplings*

San Marcos, TX - USA  
**1-800-458-0887**

### Bibby Transmissions

*Disc, Gear, Grid Couplings, Overload Clutches*

Dewsbury, England  
**+44 (0) 1924 460801**

Boksburg, South Africa  
**+27 11 918 4270**

### TB Wood's

*Elastomeric Couplings*

Chambersburg, PA - USA  
**1-888-829-6637** – Press #5

*For application assistance:*  
1-888-829-6637 – Press #7

*General Purpose Disc Couplings*

San Marcos, TX - USA  
**1-888-449-9439**

### Ameridrives Power Transmission

*Universal Joints, Drive Shafts, Mill Gear Couplings*

Green Bay, WI - USA  
**1-920-593-2444**

### Huco Dynatork

*Precision Couplings and Air Motors*

Hertford, England  
**+44 (0) 1992 501900**  
Charlotte, NC - USA  
**1-800-825-6544**

## Heavy Duty Clutches and Brakes

### Wichita Clutch

*Pneumatic Clutches and Brakes*

Wichita Falls, TX - USA  
**1-800-964-3262**

Bedford, England  
**+44 (0) 1234 350311**

### Twiflex Limited

*Caliper Brakes and Thrusters*

Twickenham, England  
**+44 (0) 20 8894 1161**

### Industrial Clutch

*Pneumatic and Oil Immersed Clutches and Brakes*

Waukesha, WI - USA  
**1-262-547-3357**

## Gearing

### Boston Gear

*Enclosed and Open Gearing, Electrical and Mechanical P.T. Components*

Charlotte, NC - USA  
**1-800-825-6544**

*For application assistance:*  
1-800-816-5608

### Bauer Gear Motor

*Gearred Motors*

Esslingen, Germany  
**+49 (711) 3518-0**

### Nuttall Gear and Delroyd Worm Gear

*Worm Gear and Helical Speed Reducers*

Niagara Falls, NY - USA  
**1-716-298-4100**

## Overrunning Clutches

### Formsprag Clutch

*Overrunning Clutches and Holdbacks*

Warren, MI - USA  
**1-800-348-0881** – Press #1

*For application assistance:*  
1-800-348-0881 – Press #2

### Marland Clutch

*Roller Ramp and Sprag Type Overrunning Clutches and Backstops*

South Beloit, IL - USA  
**1-800-216-3515**

### Stieber Clutch

*Overrunning Clutches and Holdbacks*

Heidelberg, Germany  
**+49 (0) 6221 30 47 0**

## Belted Drives and Sheaves

### TB Wood's

*Belted Drives*

Chambersburg, PA - USA  
**1-888-829-6637** – Press #5

*For application assistance:*  
1-888-829-6637 – Press #7

## Engineered Bearing Assemblies

### Kilian Manufacturing

*Engineered Bearing Assemblies*

Syracuse, NY - USA  
**1-315-432-0700**

*For information concerning our sales offices in Asia Pacific check our website*  
[www.altramotion.com.cn](http://www.altramotion.com.cn)



[www.warnerelectric.com](http://www.warnerelectric.com)

31 Industrial Park Road  
New Hartford, CT 06057 - USA  
815-389-3771  
Fax: 815-389-2582