

# ZKX Series

## 磁粉式電磁煞車器 (中空軸型式) Magnetic Particle Brake (Hallow-shaft type)

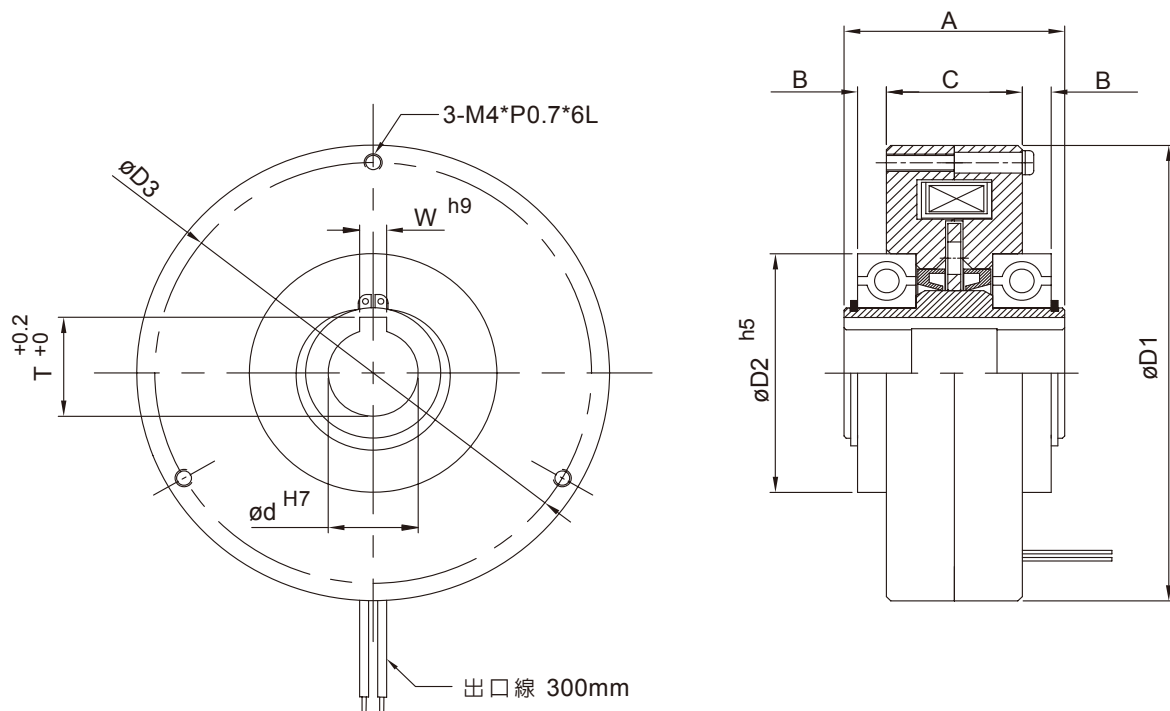

型號 MODEL	ZKX0S3AA	ZKX0S6AA	ZKX1S2AA	
定格扭力 [kgm] (Nm) Rated torque	3	6	12	
容量 Capacity DC24V (75°C)	電流 (A) Current	0.4	0.5	
	電力 (W) Power	9.6	12	
	時定數 (S) Number of hours set	0.035	0.05	
慣性矩 J Moment of inertia (kgm <sup>2</sup> )	$3.5 \times 10^{-5}$	$9 \times 10^{-5}$	$1.6 \times 10^{-4}$	
最高回轉速 (r/min) Max speed	400			
外型尺寸 Exterior dimensions	A	43	49	50
	B	6.5	6.5	7
	C	25	30	30
	D1	88	105	118
	D2	47	55	62
	D3	80	97	110
	d	15	20	25
鍵槽 Keyway	W	5	6	8
	T	17.3	22.8	28.3