

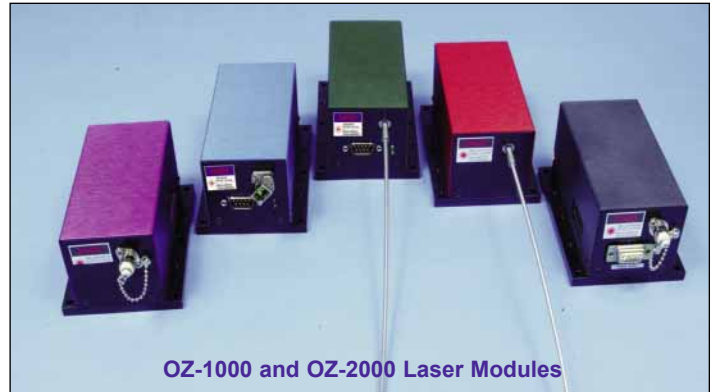

## FIBER PIGTAILED ULTRA STABLE LASER MODULE OZ-1000, OZ-2000 & OZ-3000 SERIES

### Features:

- Output power up to 300 mW
- Wavelengths from 375 nm to 2050 nm available
- Guaranteed lifetime: 18 months or 5000 hours. Extended warranty is also available
- Excellent power & wavelength stability
- Low RMS noise
- Electrically or optically variable output power
- Easily configured analog interface
- USB interface optional; other interfaces are also available
- Level 4 ESD protection
- Single mode, multimode, or polarization maintaining fiber version
- Available with fiber pigtail or connector receptacle
- Optional collimator or focuser on the pigtail output
- Compact size and low cost



OZ-1000 and OZ-2000 Laser Modules

### Applications:

- Confocal microscopy
- Flow cytometry
- DNA sequencing
- Medical imaging, including OCT
- Insertion loss measurement and attenuation measurement
- High power or remote fiber delivery systems
- Accurate fiber optic testing
- Optical component manufacturing and testing
- Materials evaluation and testing
- RGB illumination systems



OZ-3000 Laser Module (front view)



OZ-3000 Laser Module (rear view) with optional inputs for TTL and analog modulation

Generic product specification <sup>1</sup>					Comments
Wavelength (nm)	375, 405, 445, 473, 488, 520	635, 650, 685, 785, 808, 830, 850	980, 1060	1310, 1480, 1550, 1625, 2000	Peak wavelength emission depends on the laser diode. For other wavelengths contact OZ Optics.
SM/PM Output power (mW)	Up to 30	Up to 60	Up to 300	Up to 20	Higher output power with multimode fiber
Short-term power stability	<0.1%				Measured over 1 minute
Long-term power stability	<2%	<2%	<2%	<1%	Measured over 8 hours
RMS noise	<0.2%				20Hz–2MHz bandwidth
Wavelength stability (nm)	± 0.2				Assumes absence of mode-hopping
Analog modulation	20KHz				Via power control line
Digital modulation	1MHz				Optional through SMA connector
OZ-1000/2000	Dimension (mm)	114x80x61			OZ-2000 electrical interface will be on the rear panel
	Weight (kg)	<0.6			
	Electrical Pin interface	9 Pin DB-sub			
OZ-3000	Dimension (mm)	101.6x50x38			USB interface comes as standard
	Weight (kg)	<0.35			
	Electrical Pin interface	8 Pin circular + USB interface			

<sup>1</sup> For more specific information, please refer to the following pages.

## Product Description:

The OZ-1000, OZ-2000 and OZ-3000 laser modules are temperature stabilized, fiber coupled, laser delivery systems. The standard OZ-1000, OZ-2000 and OZ-3000 units operate the laser at a fixed temperature. The compact housing contains both the laser and the temperature control, and are powered by a single 5 V DC supply. The low noise laser diode and TEC drivers maintain the wavelength variation to better than 0.2 nm, and also reduces the tendency of the laser diode to mode hop, assuming there is no feedback into the laser cavity.

The electrical interface on the OZ-1000 is located on the front face of the unit alongside the optical interface, while on the OZ-2000 and OZ-3000 it is on the rear of the unit. The three configurations have as default analog CW output power control, with analog modulation capability. A TTL input interface is optional. Our low profile OZ-3000 comes with a USB interface and an 8 pin circular connector. The units are equipped with an adjustable output power feature. The output power can be adjusted by simply changing the DC voltage on the Power Control Input. The voltage range is 0–5 V, with 0 V corresponding to maximum power, and 5 V minimum power.

Standard modules can be analog modulated up to 20 kHz. Special versions are available from OZ Optics to cover even higher modulation frequencies, up to 1 MHz for the TTL option. Contact OZ Optics with your requirements.

A manual blocking-style attenuator can be added as an option to adjust the power. This reduces the tendency of the laser diode to change wavelength when varying power, by allowing the user to keep the laser diode current constant.

An interlock feature is also standard. This enables the user to shut the unit down if a safety issue or other error condition arises. This feature can also be used as a TTL on/off control. In addition a mechanical shutter option is available to provide extra flexibility for controlling laser output power.

The unit can be configured with our patented inline optical tap for forward power monitor feedback, to further improve short term and long term power stability.

The sources come with a 5000 hour or 18 month warranty term, except for wavelengths shorter than 600 nm.

Both the pigtail and receptacle style sources offer the choice of polarization maintaining, singlemode, or multimode fiber outputs and a wide range of connector or receptacle types. An output fiber collimator or focuser can be added to the output fiber as an option.

## Standard Product Specifications:

### Optical Performance

AVAILABLE WAVELENGTHS <sup>1</sup> (nm)																				
Wavelength (nm)	375	405	440	473	488	520	532	635	660	685	780	830	850	980	1060	1310	1490 <sup>2</sup>	1550	1625	2000
Standard Fiber Coupled Output Power (mW)	0.5 1.0 2.0 3.0	1 10 20 30	5-20	5-30	8-20	5-20	5-20	1 5 10 20 40	10 20 40	10	5 10 20 35 40 60	1 5 10 20 40 60	1 5 10 20 300	50 150 50 100 100 150	5 15 50 100 100 150	1 10 20	1-2	1 10 20	2 5 10	1 2 4
Long-term Power Stability (8 hr) <sup>3</sup>	<1%						Typically <1%						Typically <1%				<2%			
Short-term Power Stability (1 min) <sup>3</sup>	Typically <1.5% Better stability available as an option						Typically <1.1%						Typically <1.1%				<0.1%			
Polarization Extinction ratio <sup>4</sup>	>18 dB						>20 dB						>23 dB				>20			
Wavelength Stability <sup>5</sup>	Typically $\pm 0.2$ nm																			
RMS Noise (20 Hz to 2 MHz)	< 0.2% other than 532 nm																			
Peak to Peak Noise (20 Hz to 2 MHz)	< 0.75% other than 532 nm																			
Fiber Type	Singlemode, Multimode or Polarization maintaining fiber																			

- These are standard center wavelengths. Typical tolerances vary from  $\pm 5$  nm to  $\pm 20$  nm depending on laser diode manufacturer. Contact OZ Optics if a specific wavelength is required.
- Other available CWDM wavelengths are: 1430 nm, 1450 nm, 1470 nm, 1510 nm, and 1530 nm.
- Depends on the source wavelength, power level and other options. Refers to typical values achieved at full power over a period of 8 hours for the long-term case and 1 minute for the short-term case after 15 minute warm up time. Tested with low return loss connector at low power laser module with no bias on power control line.
- With polarization maintaining fiber only.
- Based on thermal stability achieved with TEC controller and optimum connector termination. Assumes absence of mode-hopping.

### Electrical Specifications

Power supply	5 VDC $\pm 5\%$
Operating Current	Typically <1.2 A for standard product, 4 A for high power
Power Consumption	<6 W typical
Warm up time	<1 min
Analog/TTL Control Interface	Via 8 pin circular connector
Computer interface	USB
Power control	0 to 5 V (100% - 1%)
Analog Modulation	Up to 20 kHz
Pulse Modulation	Up to 1 MHz

### Analog/TTL interface 8 pin circular connector pin out<sup>1</sup>

1	Input	5 VDC
2	Input	GND
3	Input	Laser ON/OFF control
4	Input	Power control (analog modulation)
5	Output	Read laser current
6	Output	Read laser monitor current
7	Output	Fault status (Temp fault, over current)
8	Output	Temperature locked

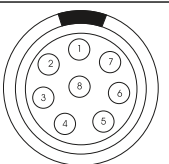

- OZ-3000 PIN configuration assignment may differ depending on requested features. Check product operating instructions to confirm PIN assignment.

### Mechanical and Environmental Specifications

Dimensions	114 x 80 x 61 mm (4.50 x 3.15 x 2.40 inch) (OZ 1000 & OZ 2000)
	101.6 x 50 x 38 mm (4 x 2 x 1.5 inch) (OZ 3000)
Operating Temperature	10 to 45 °C
Operating Humidity	0-95% Non-condensing
Storage Temperature	0-50°C



\* This module sold for OEM applications; purchaser is responsible for compliance with all safety regulations.

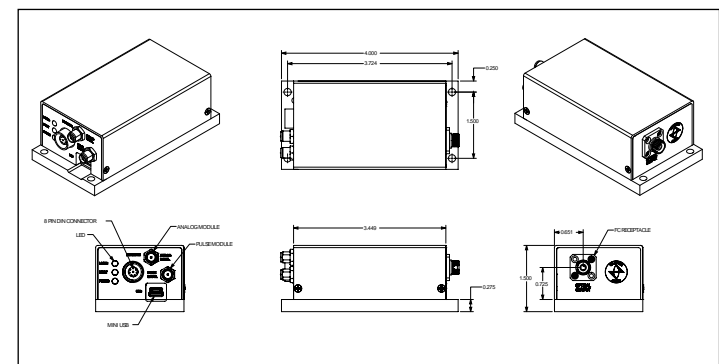
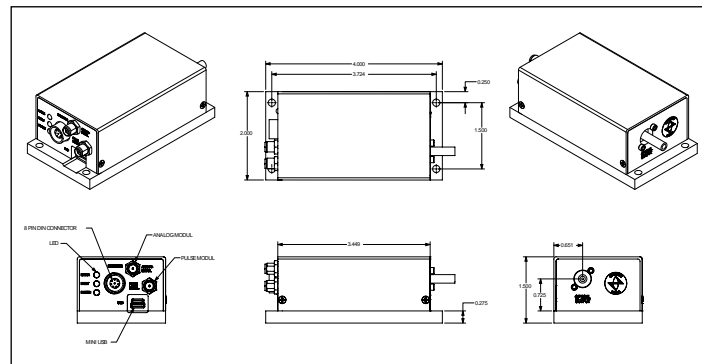
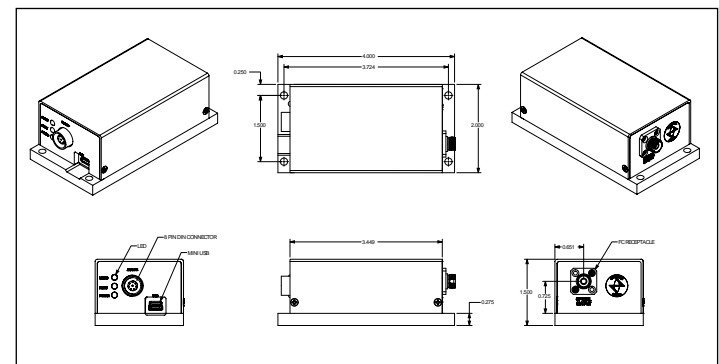
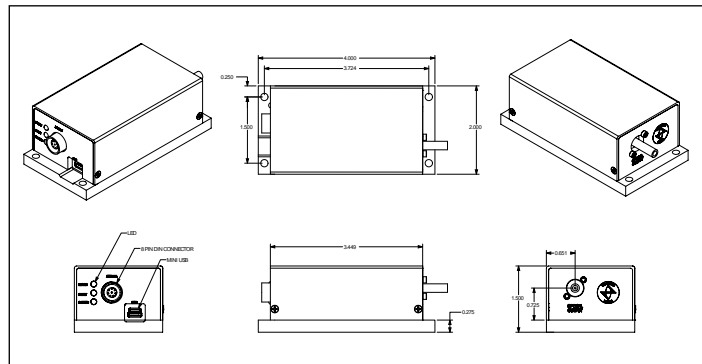
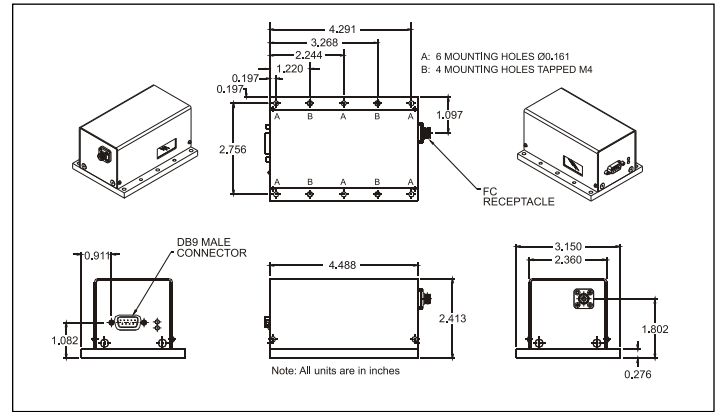
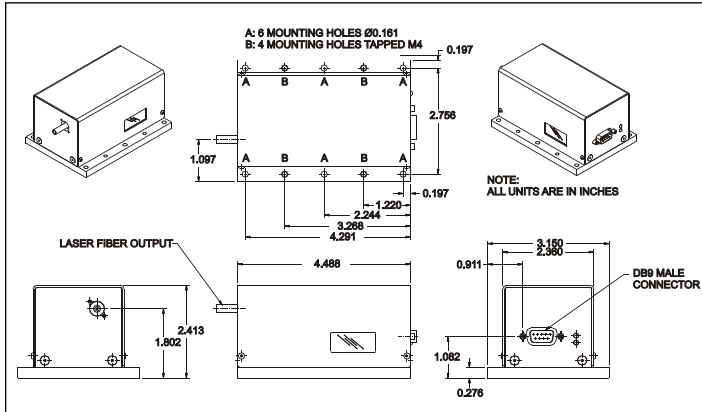
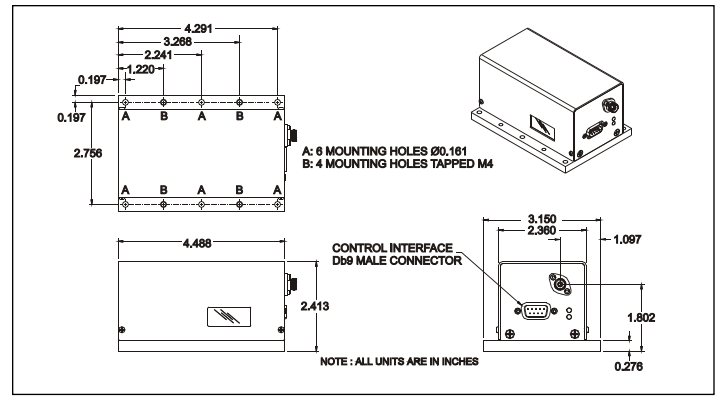
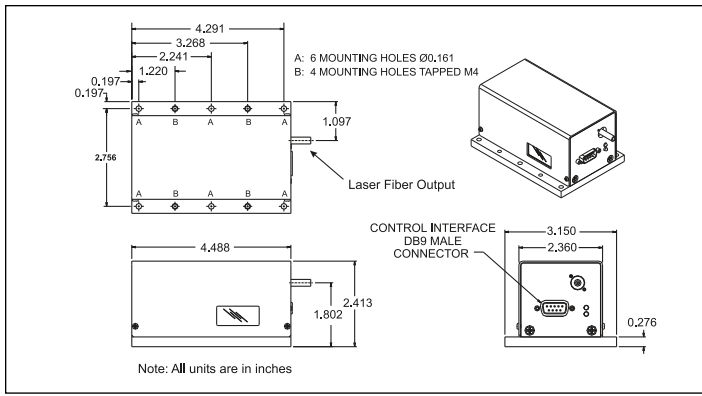

**Warranty and Lifetime**

18 months or 5000 hours, whichever comes first when operated under the environmental conditions as stated above. Not applicable for wavelengths less than 600 nm, for which the manufacturer's warranty for appropriate laser diodes will apply. The warranty does not apply for damage to exposed fiber or connectors. Please consult OZ Optics for extended warranty for up to 5 years.

**Laser Eye Safety**

**Warning:** Up to class 3B products. Read and follow the appropriate laser safety warnings. Avoid direct exposure to the eyes and implement a level of laser safety that is appropriate for this class of laser as serious injury can result from improper use.

## Detailed Product Specifications:

### 375 nm Sources:

#### Optical Performance

Output Power (mW)	Up to 7 mW
Fiber Type	2/125 $\mu$ m SM, 2/125 $\mu$ m PM or multimode
Power Stability <sup>1</sup> - Long term Short term	Typically <2% Typically <0.5%, 0.1% available as an option
Polarization Extinction Ratio <sup>2</sup> (dB)	$\geq 18$ dB
Wavelength Stability <sup>3</sup> (nm)	Typically $\pm 0.2$ nm

- 1 Depends on the power level and other options. Refers to typical values achieved over a period of 24 hours for the long-term case and 1 minute for the short-term case after 15 minutes warm up time and at 100% operating output powers.
- 2 With polarization maintaining fiber only.
- 3 Based on thermal stability achieved with TEC controller and optimum connector termination with low return loss. Assumes absence of mode-hopping.

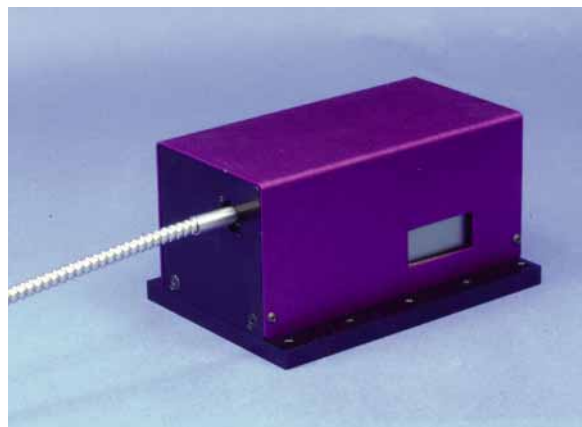

#### Standard Parts

Bar Code	Part Number	Description
27358	OZ-2000-375-2/125-S-40-3S-3A-1-3	Pigtail style, self-contained thermally stabilized OEM 375 nm, 3 mW fiber coupled source module. The output fiber is 2/125 $\mu$ m singlemode, 1 m long, 3 mm OD armour cabled fiber terminated with an Super FC/PC connector. Electrical connections are located in the rear panel.

### 405 nm Sources:

#### Optical Performance

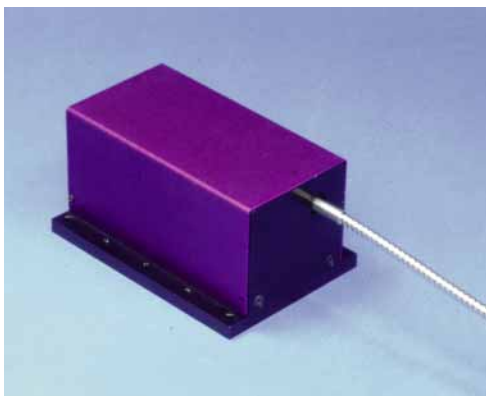

Output Power (mW)	1, 10, 20, 30
Fiber Type	3/125 $\mu$ m SM, 3/125 $\mu$ m PM, or multimode
Power Stability <sup>1</sup> - Long term Short term	Typically <2% Typically <0.5%, 0.1% available as an option
Polarization Extinction Ratio <sup>2</sup> (dB)	$\geq 18$ dB
Wavelength Stability <sup>3</sup> (nm)	Typically $\pm 0.2$ nm

- 1 Depends on the power level and other options. Refers to typical values achieved over a period of 24 hours for the long-term case and 1 minute for the short-term case after 15 minutes warm up time and at 100% operating output powers.
- 2 With polarization maintaining fiber only.
- 3 Based on thermal stability achieved with TEC controller and optimum connector termination. Assumes absence of mode-hopping.

#### Standard Parts

Bar Code	Part Number	Description
49877	OZ-2000-405-3/125-P-40-3A-3A-1-10	Pigtail style, self-contained OEM 405 nm, 10 mW fiber coupled source module. The output fiber is 3/125 $\mu$ m PANDA style polarization maintaining fiber, 1 meter long, with 3 mm black armor cable and terminated with an angled FC/APC connector. The output polarization is aligned parallel to the connector key. Electrical connections are located in rear panel.
19431	OZ-1000-405-3/125-S-40-3S-3A-1-1	Pigtail style, self-contained thermally stabilized OEM 405 nm, 1 mW fiber coupled source module. The output fiber is 3/125 $\mu$ m SM, 1 m long, with 3 mm armoured fiber terminated with a super FC/PC connector. Electrical connections are on the front panel.
19424	OZ-2000-405-3/125-S-40-3S-3A-1-1	Pigtail style, self-contained thermally stabilized OEM 405 nm, 1 mW fiber coupled source module. The output fiber is 3/125 $\mu$ m SM, 1 m long, with 3 mm armoured fiber terminated with a super FC/PC connector. Electrical connections are located in rear panel.
19426	OZ-1000-405-3/125-S-40-3S-3A-1-10	Pigtail style, self-contained thermally stabilized OEM 405 nm, 8 - 10 mW fiber coupled source module. The output fiber is 3/125 $\mu$ m SM, 1 m long, with 3 mm armoured fiber terminated with a super FC/PC connector. Electrical connections are on the front panel.
20071	OZ-2000-405-3/125-S-40-3S-3A-1-10	Pigtail style, self-contained thermally stabilized OEM 405 nm, 8 - 10 mW fiber coupled source module. The output fiber is 3/125 $\mu$ m SM, 1 m long, with 3 mm armoured fiber terminated with a super FC/PC connector. Electrical connections are located in rear panel.
43717	OZ-2000-405-3/125-P-40-3S-3A-1-30	Pigtail style, self-contained thermally stabilized OEM 405 nm, 30 mW fiber coupled source module. The output fiber is 3/125 PANDA style polarization maintaining fiber, 1 m long, with 3 mm armoured cable and terminated with a Super FC/PC connector. Electrical connections are located in rear panel.

**440-520 nm Sources:  
Optical Performance**

Output Power (mW)	Up to 20 mW @ 440 nm, 488 nm, and 520 nm and up to 30 mW @ 473 nm
Fiber Type	3.5/125 µm SM, 3.5/125 µm PM, or multimode
Power Stability <sup>1</sup> - Long term Short term	Typically <2% Typically <0.5%, 0.1% available as an option
Polarization Extinction Ratio <sup>2</sup> (dB)	≥18 dB
Wavelength Stability <sup>3</sup> (nm)	Typically ± 0.2 nm

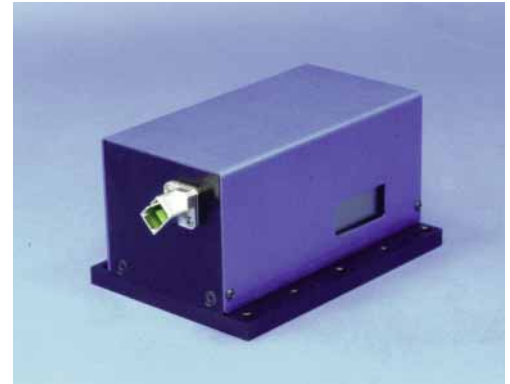

- <sup>1</sup> Depends on the power level and other options. Refers to typical values achieved over a period of 24 hours for the long-term case and 1 minute for the short-term case after 15 minutes warm up time and at 100% operating output powers.
- <sup>2</sup> With polarization maintaining fiber only.
- <sup>3</sup> Based on thermal stability achieved with TEC controller and optimum connector termination. Assumes absence of mode-hopping.

**Standard Parts**

Bar Code	Part Number	Description
27357	OZ-2000-440-3.5/125-S-40-3S-3A-1-10	Pigtail style, self-contained thermally stabilized OEM 440 nm, 10 mW fiber coupled source module. The output fiber is 3.5/125 µm singlemode fiber, 1 m long, with 3 mm armoured fiber terminated with a super FC/PC connector. Electrical connections are located in rear panel.
27359	OZ-2000-473-3.5/125-S-40-3S-3A-1-5	Pigtail style, self-contained thermally stabilized OEM 473 nm, 5 mW fiber coupled source module. The output fiber is 3.5/125 µm singlemode, 1 m long, 3 mm OD armour cabled fiber, terminated with a Super FC/PC connector. Electrical connections are located in rear panel.

**532<sup>1</sup> nm Sources:  
Optical Performance**



Output Power (mW)	Up to 20
Fiber Type	3.5/125 µm SM, 3.5/125 µm PM, or multimode
Power Stability <sup>2</sup> - Long term Short term	Typically <5% Typically <0.5%
Polarization Extinction Ratio <sup>3</sup> (dB)	≥18 dB
Wavelength Stability <sup>4</sup> (nm)	Typically ± 0.2 nm

- <sup>1</sup> Unit is built using a diode pumped solid state laser.
- <sup>2</sup> Depends on the power level and other options. Refers to typical values achieved over a period of 24 hours for the long-term case and 1 minute for the short-term case after 15 minutes warm up time and at 100% operating output powers.
- <sup>3</sup> With polarization maintaining fiber only.
- <sup>4</sup> Based on thermal stability achieved with TEC controller and optimum connector termination. Assumes absence of mode-hopping.

**Standard Parts**

Bar Code	Part Number	Description
27360	OZ-2000-532-3.5/125-S-40-3S-3A-1-20	Pigtail style, self-contained thermally stabilized OEM 532 nm, 20 mW fiber coupled source module. The output fiber is 3.5/125 µm singlemode, 1 m long, 3 mm OD armour cabled fiber terminated with an Super FC/PC connector. Electrical connections are located in the rear panel.

**635-730 nm Sources:  
Optical Performance**

Output Power (mW)	1, 5, 10, 20 at various wavelengths - please consult OZ Optics with your requirements
Fiber Type	4/125 $\mu$ m SM, 4/125 $\mu$ m PM, or multimode
Power Stability <sup>1</sup> - Long term Short term	Typically <2% Typically <0.1%
Polarization Extinction Ratio <sup>2</sup> (dB)	>20
Wavelength Stability <sup>3</sup> (nm)	Typically $\pm$ 0.2 nm

- <sup>1</sup> Depends on the power level and other options. Refers to typical values achieved over a period of 24 hours for the long-term case and 1 minute for the short-term case after 15 minutes warm up time and at 100% operating output powers.
- <sup>2</sup> With polarization maintaining fiber only.
- <sup>3</sup> Based on thermal stability achieved with TEC controller and optimum connector termination. Assumes absence of mode-hopping.



**Standard Parts**

Bar Code	Part Number	Description
19430	OZ-1000-635-4/125-S-40-3S-3A-1-1	Pigtail style, self-contained thermally stabilized OEM 635 nm, 1 mW fiber coupled source module. The output fiber is 4/125 $\mu$ m SM, 1 m long, with 3 mm armoured fiber terminated with a super FC/PC connector. Electrical connections are located on the front panel.
19429	OZ-2000-635-4/125-S-40-3S-3A-1-1	Pigtail style, self-contained thermally stabilized OEM 635 nm, 1 mW fiber coupled source module. The output fiber is 4/125 $\mu$ m SM, 1 m long, with 3 mm armoured fiber terminated with a super FC/PC connector. Electrical connections are located in rear panel.
19428	OZ-2000-635-4/125-S-40-3S-3A-1-10	Pigtail style, self-contained thermally stabilized OEM 635 nm, 10 mW fiber coupled source module. The output fiber is 4/125 $\mu$ m SM, 1 m long, with 3 mm armoured fiber terminated with a super FC/PC connector. Electrical connections are located in rear panel.
19427	OZ-1000-635-4/125-S-40-3S-3A-1-10	Pigtail style, self-contained thermally stabilized OEM 635 nm, 10 mW fiber coupled source module. The output fiber is 4/125 $\mu$ m SM, 1 m long, with 3 mm armoured fiber terminated with a super FC/PC connector. Electrical connections are located on the front panel.
18359	OZ-1000-3S-50/125-635-M-25	Receptacle style, self-contained, thermally stabilized, OEM laser diode to fiber coupler module 635 nm with 25 mW output and a 50/125 $\mu$ m MM fiber terminated with a super FC/PC receptacle. Electrical connections are located on the front panel.
16780	OZ-1000-660-4/125-P-50-3S-5A-0.5-20	Pigtail style, self-contained OEM laser diode to fiber coupler module 660 nm, 18-20 mW output, 0.5 m long, 5 mm armoured 4/125 $\mu$ m PM fiber terminated with an FC super PC connector. Slow axis of PM fiber aligned with connector keyway. Electrical connections are located on the front panel.
26381	OZ-1000-680-4/125-S-40-3S-3A-1-10	Self-contained OEM Fabry Perot laser diode to fiber coupler module 680 nm, 10-12 mW output, 1 m long, 3 mm armoured 4/125 $\mu$ m SM fiber terminated with an FC super PC connector. Electrical connections are located on the front panel.

**750-850 nm Sources:  
Optical Performance**

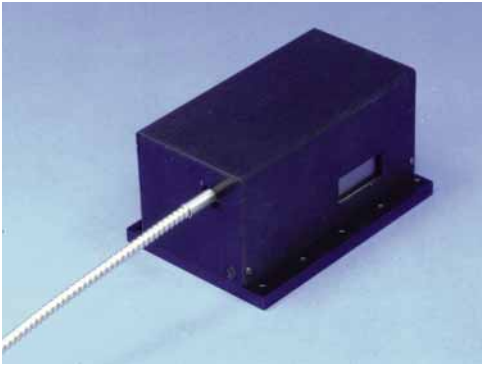

Output Power (mW)	1, 5, 10, 20, 35, 40, 60 at various wavelengths - please consult OZ Optics with your requirements
Fiber Type	5/125 $\mu$ m SM, 5/125 $\mu$ m PM, or multimode
Power Stability <sup>1</sup> - Long term Short term	Typically <2% Typically <0.1%
Polarization Extinction Ratio <sup>2</sup> (dB)	$\geq 20$
Wavelength Stability <sup>3</sup> (nm)	Typically $\pm 0.2$ nm

- 1 Depends on the power level and other options. Refers to typical values achieved over a period of 24 hours for the long-term case and 1 minute for the short-term case after 15 minutes warm up time and at 100% operating output powers.
- 2 With polarization maintaining fiber only.
- 3 Based on thermal stability achieved with TEC controller and optimum connector termination. Assumes absence of mode-hopping.

**Standard Parts**

Bar Code	Part Number	Description
18834	OZ-1000-780-5/125-S-40-3U-3-1-5	Pigtail style, self-contained thermally stabilized OEM laser diode to fiber coupler module 780 nm, 5 mW output, 1 m long, 3 mm OD PVC cabled 5/125 $\mu$ m SM fiber terminated with an ultra FC/UPC connector. Electrical connections are located on the front panel.
15139	OZ-1000-830-5/125-P-60-3S-5A-0.5-60	Pigtail style, self-contained OEM laser diode to fiber coupler module 830 nm, 60 mW output, 0.5 m long, 5 mm black armored 5/125 $\mu$ m PM fiber terminated with a super FC/PC connector. The slow axis of the PM fiber is aligned to the connector keyway. Includes a PMPC FC/PC sleeve-thru adaptor with a 2.06 mm keyway. Electrical connections are located on the front panel.
23075	OZ-2000-830-5/125-P-40-3A-1-1-10	Pigtail style, self-contained thermally stabilized OEM 830 nm, 10 mW fiber coupled source module with 1 m long, 1 mm OD jacketed, 5/125 $\mu$ m PM fiber, terminated with an angled FC/APC connector aligned and locked along slow axis. Electrical connections are located in rear panel.
21613	OZ-2000-850-5/125-S-40-3S-3-1-50	Pigtail style, self-contained thermally stabilized OEM 850 nm, 50 mW fiber coupled source module with 1 m long, 3 mm OD PVC cabled, 5/125 $\mu$ m SM fiber, terminated with a super FC/PC connector. Electrical connections are located in rear panel.
22590	OZ-2000-3A-5/125-830-P-10	Receptacle style, self-contained thermally stabilized OEM 830 nm FP, 10 mW fiber coupled source module. The fiber inside is a 5/125 $\mu$ m PM fiber terminated with an angled FC/APC connector with a key aligned and locked along the fiber slow axis. Electrical connections are located in rear panel.

**960-1100 nm Sources:  
Optical Performance**

Output Power (mW)	Up to 300 @ 980 nm and up to 150 @ 1060 nm
Fiber Type	6/125 $\mu$ m SM, 5 or 6/125 $\mu$ m PM, or multimode
Power Stability <sup>1</sup> - Long term Short term	Typically <2% Typically <0.1%
Polarization Extinction Ratio <sup>2</sup> (dB)	$\geq 20$
Wavelength Stability <sup>3</sup> (nm)	Typically $\pm 0.2$ nm

- 1 Depends on the power level and other options. Refers to typical values achieved over a period of 24 hours for the long-term case and 1 minute for the short-term case after 15 minutes warm up time and at 100% operating output powers.
- 2 With polarization maintaining fiber only.
- 3 Based on thermal stability achieved with TEC controller and optimum connector termination. Assumes absence of mode-hopping.

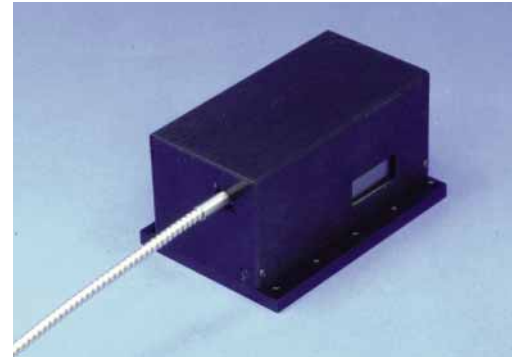

**Standard Parts**

Bar Code	Part Number	Description
21614	OZ-2000-980-6/125-S-40-3S-3-1-50	Pigtail style, self-contained thermally stabilized OEM 980 nm, 50 mW fiber coupled source module with 1 m long, 3 mm OD PVC cabled, 6/125 $\mu$ m SM fiber, terminated with a super FC/PC connector. Electrical connections are located in rear panel.
21885	OZ-2000-1064-6/125-P-40-3A-3-1-10	Pigtail style, self-contained thermally stabilized OEM 1064 $\pm 5$ nm, 10 mW fiber coupled source module. The output fiber is 6/125 $\mu$ m PM, 1 m long, 3 mm OD PVC cabled fiber terminated with an angled FC/APC connector with a key that aligned and locked along fiber slow axis. Electrical connections are located in rear panel.
22532	OZ-2000-3A-6/125-980-P-50	Receptacle style, self-contained thermally stabilized OEM 980 nm, 6/125 $\mu$ m PM fiber, 50 mW fiber coupled source module terminated with an angle FC/APC connector with slow axis aligned and locked along the slow axis. Electrical connections are located in rear panel.



**1310-1490 nm Sources:  
Optical Performance**



Output Power (mW)	Up to 20 @ 1310 nm and up to 2 @ 1490 nm
Fiber Type	9/125 μm SM, 7/125 μm PM, or multimode
Power Stability <sup>1</sup> - Long term	Typically <1%
Short term	Typically <0.05%
Polarization Extinction Ratio <sup>2</sup> (dB)	>23
Wavelength Stability <sup>3</sup> (nm)	Typically ± 0.2 nm

<sup>1</sup> Depends on source wavelength, power level and other options. Refers to typical values achieved over a period of 24 hours for the long-term case and 1 minute for the short-term case after 15 minutes warm up time and at 100% operating output powers.

<sup>2</sup> With polarization maintaining fiber only.

<sup>3</sup> Based on thermal stability achieved with TEC controller and optimum connector termination. Assumes absence of mode-hopping.

**Standard Parts**

Bar Code	Part Number	Description
23090	OZ-2000-3S-50/125-1310-M-2	Receptacle style, self-contained thermally stabilized OEM 1310 nm, 2 mW fiber coupled source module. The fiber inside is a 50/125 μm MM fiber terminated with a super FC/PC receptacle. Electrical connections are located in rear panel.
26404	OZ-2000-1310-9/125-S-40-3S-3-1-20	Pigtail style, self-contained thermally stabilized OEM 1310 nm, 20 mW fiber coupled source module with 1 m long, 3 mm OD PVC cabled, 9/125 μm SM fiber, terminated with a super FC/PC connector. Electrical connections are located in rear panel.

**1550-2050 nm Sources:  
Optical Performance**

Output Power (mW)	Up to 15 @ 1550 nm and up to 10 @ 2000 nm
Fiber Type	9/125 μm SM, 8/125 μm PM, or multimode
Power Stability <sup>1</sup> - Long term	Typically <1%
Short term	Typically <0.05% ; <0.1% for 2000 nm
Polarization Extinction Ratio <sup>2</sup> (dB)	>23 ; >20 dB for 2000 nm
Wavelength Stability <sup>3</sup> (nm)	Typically ± 0.2 nm

<sup>1</sup> Depends on source wavelength, power level and other options. Refers to typical values achieved over a period of 24 hours for the long-term case and 1 minute for the short-term case after 15 minutes warm up time and at 100% operating output powers.

<sup>2</sup> With polarization maintaining fiber only.

<sup>3</sup> Based on thermal stability achieved with TEC controller and optimum connector termination. Assumes absence of mode-hopping.

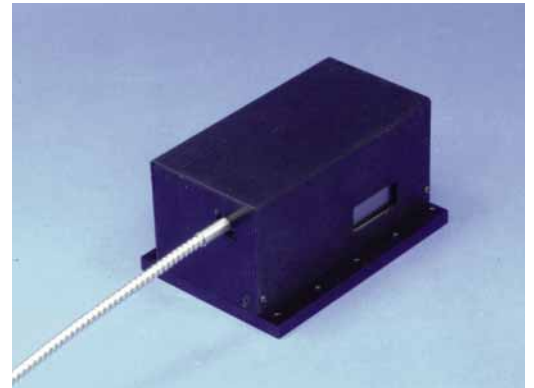

**Standard Parts**

Bar Code	Part Number	Description
22876	OZ-2000-1550-8/125-P-40-3A-3-1-1.5	Pigtail style, self-contained thermally stabilized OEM 1550 ±5 nm, 1.5 mW fiber coupled source module. The output fiber is 8/125 μm PM, 1 m long, 3 mm OD cabled fiber terminated with an angled FC/APC connector with a key that aligned and locked along fiber slow axis. Electrical connections are located in rear panel.
26877	OZ-1000-3S-8/125-1550-P-10-DFB	Receptacle style, self-contained, TE cooled, OEM DFB laser diode to fiber coupler module 1550 ±5 nm with 10 mW output, and a 8/125 PM fiber terminated with an FC/PC receptacle with key aligned and locked along the slow axis.
26920	OZ-2000-3S-9/125-1550-S-1-DFB	Receptacle style, self-contained thermally stabilized DFB 1550 nm ±5 nm, 1 mW fiber coupled source module with 9/125 μm SM terminated with an FC/PC connector. Electrical connections are located in rear panel. Internal Isolator included.
25706	OZ-2000-1550-9/125-S-40-3S-3A-1-10	Pigtail style, self-contained thermally stabilized OEM 1550 nm, 10 mW fiber coupled source module. The output fiber is 9/125 μm SM, 1 m long, with 3 mm armour fiber terminated with a super FC/PC connector. Electrical connections are located in rear panel.

**Power supply units:**

Bar Code	Part Number	Description
11147	AC-5VDC-NA	Universal 110/220 VAC to 5 V DC power supply, 30 Watts, 4 Amps, w/ IEC power cord to North American Plug.
12388	AC-5VDC-EU	Universal 110/220 VAC to 5 V DC power supply, 30 Watts, 4 Amps, w/ IEC power cord to European Plug.
16885	AC-5VDC-UK	Universal 110/220 VAC to 5 V DC power supply, 30 Watts, 4 Amps, w/ IEC power cord to United Kingdom Plug.

## Ordering Examples For Standard Parts:

A customer needs a temperature stabilized, 635 nm source capable of delivering over 10 mW from the end of a singlemode fiber terminated with an FC/PC connector. They also require a 5 V DC supply with a standard North American wall plug.

Bar Code	Part Number	Description
19427	OZ-1000-635-4/125-S-40-3S-3A-1-10	Pigtail style, self-contained thermally stabilized OEM 635 nm, 10 mW fiber coupled source module. The output fiber is 4/125 $\mu$ m SM, 1 m long, with 3 mm armored fiber terminated with a super FC/PC connector. Electrical connections are located on the front panel.
11147	AC-5VDC-NA	Universal 110/220 VAC to 5 V DC power supply, 30 Watts, 4 Amps, w/ IEC power cord to North American Plug.

## Ordering Information For Custom Parts:

OZ Optics welcomes the opportunity to provide custom designed products to meet your application needs. As with most manufacturers, customized products do take additional effort so please expect some differences in the pricing compared to our standard parts list. In particular, we will need additional time to prepare a comprehensive quotation, and lead times will be longer than normal. In certain cases non-recurring engineering (NRE) charges, lot charges, and/or a minimum order will be necessary. These points will be carefully explained in your quotation, so your decision will be as well-informed as possible.

## Questionnaire

1. What wavelength do you need?
2. How much output power do you need?
3. Do you want a built-in fiber, or a receptacle to attach your own fiber?
4. What size and type of fiber do you require?
5. How long a fiber do you need?
6. What kind of fiber connectors are you using?
7. Do you need a collimated output beam?
8. If a collimated beam is required, what is the desired beam diameter?
9. If a focused spot is required, what is the desired spot size and working distance?
10. Do you want a built-in isolator?

## Description:

### Pigtail Style Source

### Part Number

**OZ-N000-W-a/b-F-LB-X-JD-L-P**

**N** = 1000 for electrical and optical connections in same front panel  
 2000 for electrical connection on rear panel and optical connection on front panel  
 3000 compact version

**W** = Wavelength <sup>1</sup>: 375, 405, 440, 473, 488, 520, 532, 635, 660, 685, 780, 830, 850, 980, 1060, 1310, 1490, 1550, 1625, 2000.

**a/b** = Fiber size: core/cladding diameters (in  $\mu$ m): (see tables 1 to 5 in the *Standard Tables* [http://www.ozoptics.com/ALLNEW\\_PDF/DTS0079.pdf](http://www.ozoptics.com/ALLNEW_PDF/DTS0079.pdf) data sheet)

**F** = Fiber type: M = Multimode Fiber  
 S = Singlemode Fiber  
 P = Polarization Maintaining Fiber

**LB** = Backreflection level <sup>2</sup>:  
 35 = 35 dB return loss (MM only)  
 40 = 40 dB return loss (SM & PM)  
 60 = 60 dB return loss (SM & PM - 1300/1550 nm only)

**P** = Output power available from the fiber end, in mW <sup>3</sup>

**L** = Fiber length (in meters)

**JD** = Jacket Diameter:  
 1 = 900 $\mu$ m jacketed fiber  
 3 = 3 mm OD Kevlar jacketed fiber  
 3A = 3 mm OD black armored cable  
 3AS = 3 mm OD Stainless Steel armored cable  
 5A = 5 mm OD black armored cable  
 5AS = 5 mm OD Stainless Steel armored cable

**X** = Connector type: 3 = FC/PC  
 3S = Super FC/PC  
 3A = Angled FC/APC  
 5 = SMA905  
 8 = AT&T-ST  
 SC = SC or ultra SC  
 SCA = Angled SC  
 EA = Angled E2000  
 LC = LC connector  
 For other connector types contact OZ Optics.

**Description:**  
**Receptacle Style Source**

**N** = 1000 for electrical and optical connections in same front panel  
2000 for electrical connection on rear panel and optical connection on front panel  
3000 compact version

**X** = Connector Receptacle:  
2.5U = 2.5 mm universal receptacle (for FC, ST, or SC).  
3S = Super FC/PC  
3A = Angled FC/APC  
5 = SMA905  
8 = AT&T-ST  
SC = SC  
SCA = Angled SC

**Part Number**  
**OZ-N000-X-a/b-W-F-P**

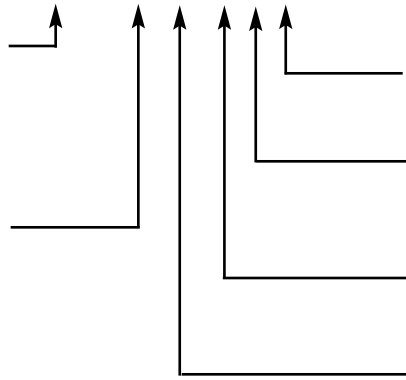

**P** = Output power<sup>3</sup>:  
Output power available from the receptacle

**F** = Fiber type: M = Multimode Fiber  
S = Singlemode Fiber  
P = Polarization Maintaining Fiber

**W** = Wavelength<sup>1</sup>: 375, 405, 440, 473, 488, 520, 532, 635, 660, 685, 780, 830, 850, 980, 1060, 1310, 1490, 1550, 1625, 2000.

**a/b** = Fiber size: core/cladding diameters (in  $\mu\text{m}$ ):  
(see Tables 1 to 5 in the *Standard Tables*  
[http://www.ozoptics.com/ALLNEW\\_PDF/DTS0079.pdf](http://www.ozoptics.com/ALLNEW_PDF/DTS0079.pdf)  
data sheet)

- <sup>1</sup> These are standard center wavelength values. The tolerance may vary depending on both wavelength and the laser diode manufacturers' tolerances. (Typical tolerances vary from  $\pm 5$  nm to as high as  $\pm 30$  nm).
- <sup>2</sup> The backreflection specification refers to the reflected signal strength relative to the output power seen by the laser diode from internal reflections. It does not include external sources of reflection, including those from the connector at the end of the fiber. To minimize external reflections, OZ Optics recommends using angle polished FC/APC or SC/APC connectors. Backreflection values are limited by the wavelength and fiber type selected. Other backreflection levels may be possible. Please contact OZ for further information.
- <sup>3</sup> Note that due to variations in the optical characteristics of the laser diodes available, not all output powers are available at every wavelength for every fiber type. For wavelengths below 750 nm, we recommend pigtail style to eliminate connection loss at the receptacle interface.

**Options:** Add **"-ISOL"** if an optical isolator is required (Please note that this option is only available for the 1300 to 1625 nm wavelength range).  
Add **"-SH"** For shutter.  
Add **"-TTL"** For up to 1 MHz modulation.  
Add **"-CSP"** For customer supplied laser diode or fiber.  
Add **"-USB"** For computer interface, for OZ-2000 and OZ-1000. USB is standard for OZ-3000.

**Ordering Examples for Custom Parts:**

A European customer needs a temperature stabilized, 635 nm source capable of delivering 15 mW from the end of a 1m long, 3 mm Stainless Steel cabled singlemode fiber.

These requirements can be met by using a pigtailed source with part number OZ-1000-635-4/125-S-40-3A-3AS-1-20. This provides 5 mW of headroom, to accommodate any degradation of the laser over time.

**Frequently Asked Questions (FAQs)**

**Q:** What is the difference between the OZ-1000 and OZ-2000 systems?

**A:** The OZ-1000 has its electrical interface located on the front panel where the optical connector is located. The OZ-2000 has its electrical interface located on the rear panel opposite of where the optical connector is located. This is to best suit our customers' needs. In all other aspects, the units are identical.

**Q:** Since the interlock feature is TTL compatible, can I use it as a TTL input for modulation?

**A:** No, although the interlock is TTL compatible, it should only be used for turning the unit on or off through a computer interface or via a safety switch.

**Q:** Do the sources have a modulation function?

**A:** A standard OZ-1000 or OZ-2000 can be modulated at low frequencies by feeding the modulation signal to the power control input. The power control signal varies the output power from 100% to 0% as the voltage changes from 0 volts to 5 volts. Most applications using modulation would require a modulation signal with a DC offset. The standard units use filters to minimize noise in the drive circuitry so as to give the cleanest possible optical signal. However, these filters also limit the bandwidth of the output. For applications that require a higher modulation capability, the bandwidth limitation can be reduced at the factory, to allow modulation of over 20 kHz. Contact OZ Optics if modulation above 20 kHz is required.

**Q:** Many laser diodes require less than 100 mA. Why does the OZ-1000 require >1 amp?

**A:** Most of the current required by the OZ-1000 is used by the Peltier element that maintains the laser at a constant operating temperature. A constant temperature is required to ensure the best possible stability, both in terms of power stability and wavelength stability. Under certain conditions, the Peltier element may require a significant current. This is especially true when the laser is first turned on, and the Peltier driver circuitry is working hard to achieve the desired operating temperature. Once the desired temperature is reached, the operating current will generally drop significantly.

**Q:** Can OZ Optics manufacture sources using a customer supplied laser diode and/or fiber?

**A:** Yes. Please provide OZ Optics with detailed information.

**Q:** Does OZ Optics offer higher power sources than what is standard on the data sheet?

**A:** Yes. Please provide OZ Optics with the requested fiber output power and fiber type and we will work with you to find a solution.

**Q:** Do you offer universal adaptors for your sources?

**A:** We can, but we do not recommend them. Universal adaptors do not have a retaining mechanism, so the fiber can fall out if you do not hold it in place. In addition, the lack of a retaining mechanism will cause the coupled power from the source to be unstable. Universal receptacles should only be used with visible sources for fault location, where you are not concerned with the power stability.

**Q:** Why do you recommend the pigtail style for wavelengths below 750 nm?

**A:** For wavelengths less than 750 nm, the fiber core size is 4 microns or smaller. For such small sizes, mechanical tolerances may result in over 1 dB (20%) losses at the receptacle interface. Using a pigtail style unit avoids this issue.

**Q:** Does OZ Optics offer a way to combine different wavelengths through a single fiber?

**A:** Yes, using a wavelength division multiplexer (WDM), OZ Optics can combine up to 3 wavelengths into a single fiber. For example, OZ Optics offers a Red, Green, Blue (RGB) combiner. Please see the data sheet titled "RGB (Red Green Blue) Combiner and Delivery Systems".

**Q:** I currently use units that had the D-Sub connector. How can I use the new units with the circular connector?

**A:** OZ Optics has available a cable to adapt the circular connector to a D-Sub connector.

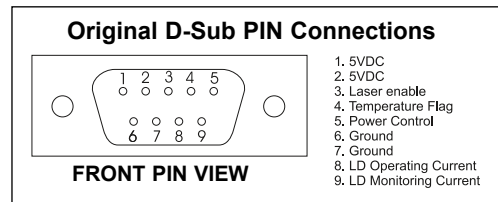

**Application Notes**

**Insertion loss and attenuation measurement**

When used with an optical power meter, the OZ-1000, OZ-2000, and OZ-3000 sources can provide an alternative to insertion loss and backreflection test sets, due to their excellent stability. For singlemode applications, such as telecom or CATV environments, the source can be coupled with an optical power meter to form a test kit that performs optical loss tests at 1300 or 1550 nm.

**Maintenance**

To ensure the best performance of your source, some simple maintenance is required.

**Cleaning the connector:** A clean connector ensures that good connections are made between the source and the fiber under test. Failure to clean the connectors can cause permanent damage to both the fiber end and the connector of the source. To avoid these failures, ensure that the unit is OFF, and clean the connector before each use with a fresh lint-free tissue and alcohol.

**Using bare fibers with sources**

A common application is to connect a fiber without any connector (bare fiber) to a source. **Do not attempt to attach a bare fiber directly to the source with a bare fiber adaptor or similar device.** Instead the best approach is to use an intermediate patchcord, with the appropriate connector on one end, and a bare fiber on the other end. The end with the connector is attached to the source or meter, and the bare fiber end is connected to the bare fiber on the device to be tested. Both fibers are first stripped, cleaned and cleaved then spliced together. This can be done with a fusion splicer, or alternatively, a simple mechanical splice (OZ Bar Code #1933) can be used. Each fiber end is first dabbed into index matching gel (GEL-01, OZ Bar Code# 2861) to act as a lubricant (Note: Index Matching Gel is only suitable for <10 mW power levels, and wavelengths longer than 600 nm). One end is inserted about half way into the splice, while the other end is pushed in until it butts against the other fiber. Losses are typically less than 1 dB, and the parts can be reused.

**Computer interface functions**

1	Set the temperature (Factory preset)
2	Set the laser power (Factory preset)
3	Set the current limit (Factory preset)
4	Read the operating time
5	Laser ON/OFF
6	Laser power control (0 to 100%)
7	Laser status
8	Read laser current
9	Read laser monitor current
10	Fault status (Temp fault, laser over current)
11	Temperature locked

# OPERATING LIFETIMES OF OZ OPTICS FIBER PIGTAILED LASER MODULES

OZ Optics has spent significant research efforts in developing laser modules with high reliability and long operating lifetimes. With the use of in-fiber directional fiber optic power monitors, these sources can achieve very high stability (< 2% variation), even compensating for over-time degradation of optical components and laser diode fluctuations. With this method, OZ Optics is able to achieve longer operation life times and greater stability than is usually achievable with laser diodes. This technique can be easily applied to other source wavelengths, including high power applications that may greatly benefit from the stability and enhanced lifetime.

The following charts give typical test data for optical sources that have been manufactured. While actual lifetimes depend on the operating wavelength, laser power, and reliability data for the laser diodes by the manufacturers, the data shown here indicates the reliability of the optics and control electronics developed by OZ Optics.

## Example 1: 670 nm sources

Chart 1 shows the output power over time for six laser diode sources, pigtailed with polarization maintaining fibers. All six sources emit 1 mW of laser power at 670 nm with a forward monitoring optical tap used to control and stabilize the output power. The devices were operated at room temperature continuously for over one year. As shown in the chart, all six devices have operated for the entire duration of the test with less than 1% reduction in output power, and are expected to operate at least 3 years with less than 5% variation.

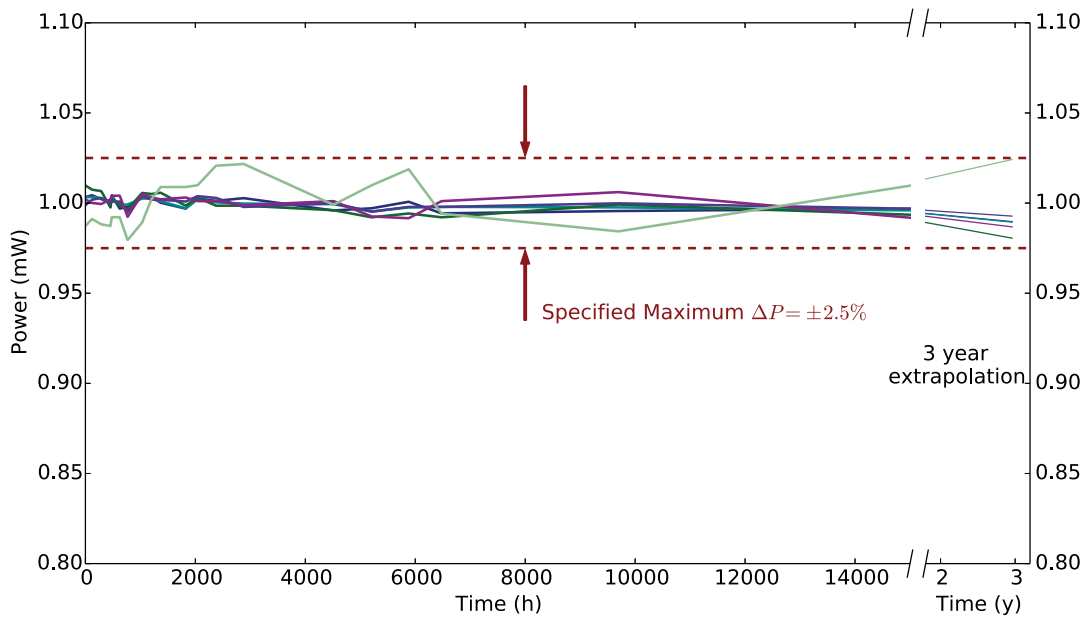

Chart 1: 670 nm source lifetime test results measured for 6 devices operating for 15000 hours.

### Example 2: 450 nm sources

Chart 2 shows the output power over time for a laser diode source, pigtailed with a polarization maintaining fiber, operating at 450 nm with 23 mW of output power. A forward monitoring optical tap was used to stabilize the source and the device was operated at room temperature continuously for over 1500 hours with less than 1.5% variation in output power.

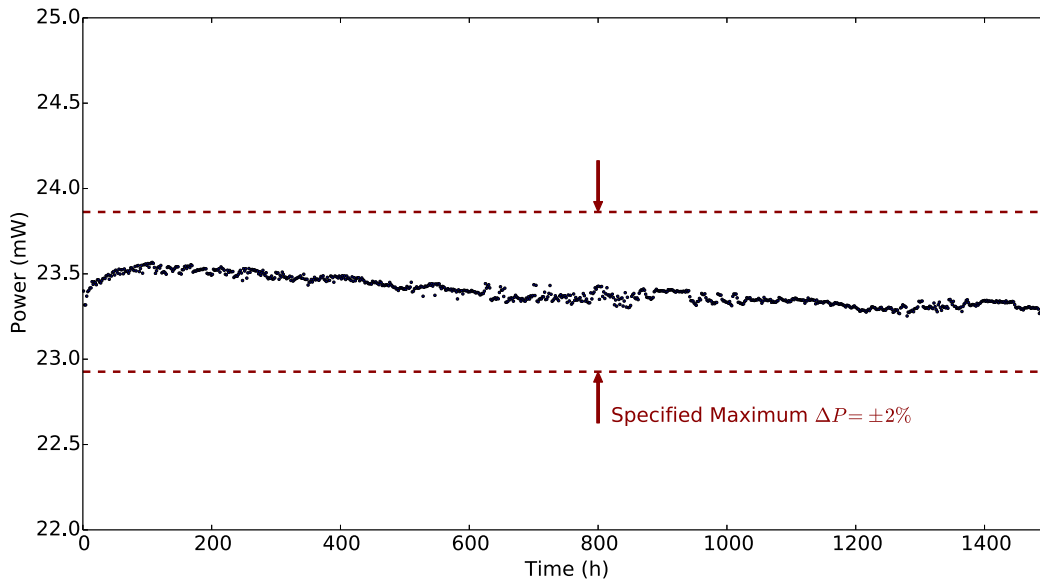

Chart 2: 450 nm source lifetime test results measured for a device operating for 1500 hours.

### Example 3: 405 nm sources

Chart 3 shows the output power over time for three laser diode sources, pigtailed with polarization maintaining fibers. All three sources emit over 30 mW of laser power at 405 nm. Power was controlled using the internal monitoring photodiode inside the laser diode housing. The devices were operated at room temperature continuously and all the units performed for 1400 hours with less than 3% variation in output power.

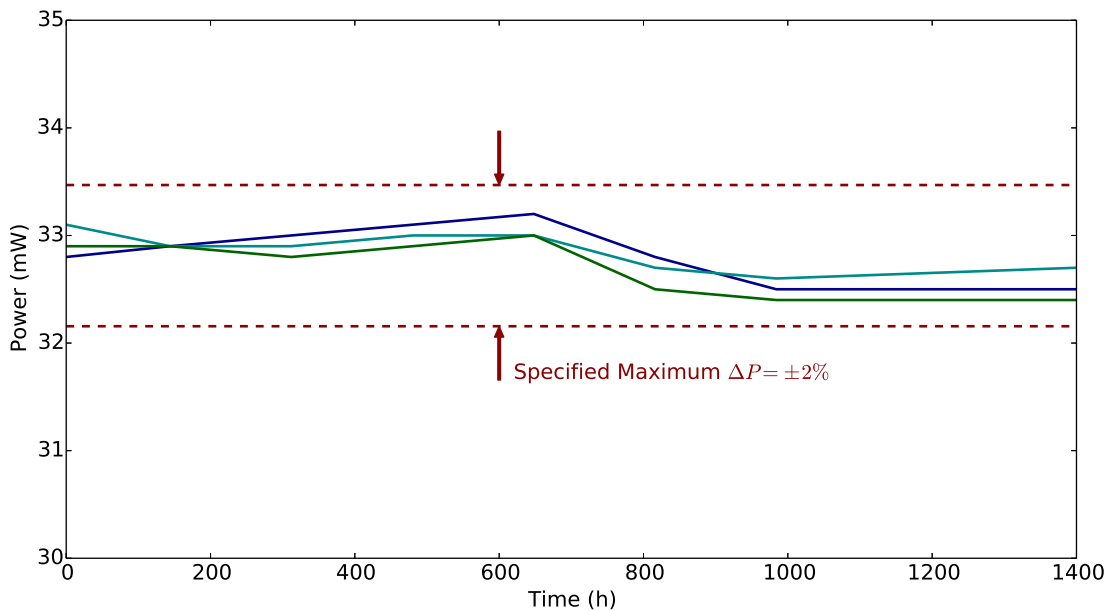

Chart 3: 405 nm source lifetime test results.