

NOTES:

1. HERMETIC LEAK RATE: LESS THAN OR EQUAL TO  $1 \times 10^{-9}$  CC/SEC He AT 1 ATM DIFFERENTIAL PRESSURE.
2. NOMINAL IMPEDANCE: 50 OHMS.
3. INSULATION RESISTANCE: 5000 MEGOHMS MINIMUM.
4. DESIGNED TO BE LASER WELDED TO ALUMINUM ALLOY 6061 HOUSINGS.
5. MATERIALS:  
 WELD FLANGE: 4000 SERIES ALUMINUM  
 CONTACT: KOVAR IAW ASTM-F15 OR EQUIVALENT.  
 INSULATOR: 7070 CORNING GLASS OR EQUIVALENT.  
 GROUND SPRING: BeCu 173/174 IAW ASTM-B194, TD04.
6. FINISH: CONTACT, BODY AND GROUND SPRING:  
 NICKEL PLATE IAW ASTM B733, TYPE I, CLASS I, OR EQUIVALENT, .000100/.000250 THICK.  
 GOLD PLATE IAW ASTM B488, TYPE III, CODE A, OR EQUIVALENT, .000050/.000150 THICK.
7. GROUND SPRING SHIPPED LOOSE AND UNATTACHED.
8. ORDERING INFORMATION:  
 PLEASE SPECIFY ACCORDING TO THE FOLLOWING:

EXAMPLE: 93843 - FD - 045

A = PIN EXTENSION (.020 MIN/.120 MAX)  
 FD = FULL DETENT, ND = NO DETENT  
 BASE PART NUMBER

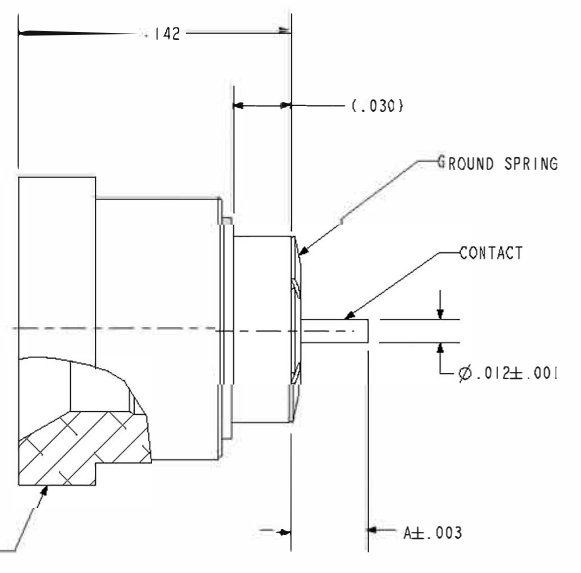
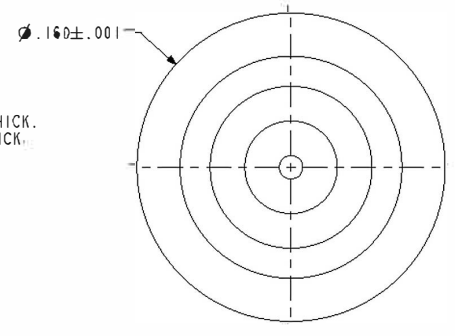

SECTION A-A

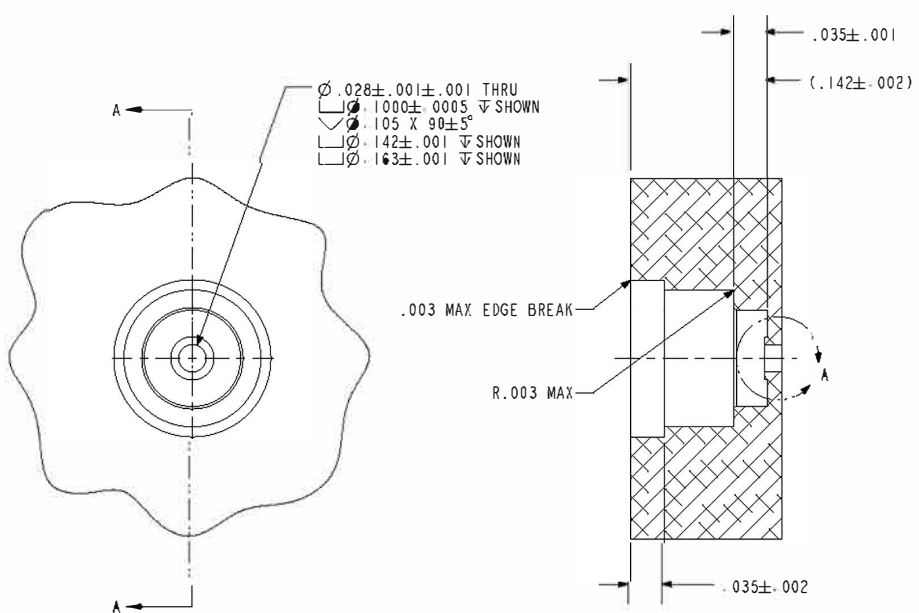

HOLE DETAIL  
SCALE 5.000

SECTION A-A

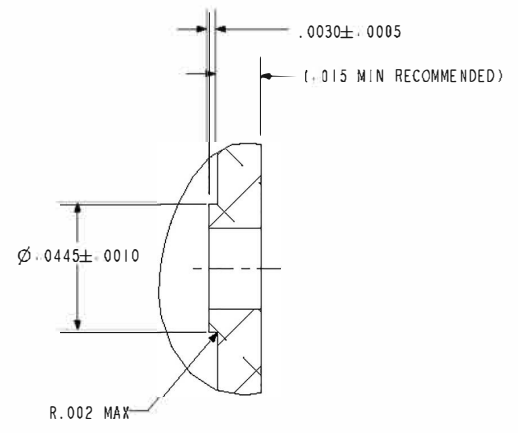

DETAIL A  
SCALE 15.000

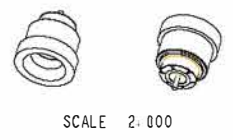

SCALE 2.000



434 Olds Station Rd. Wenatchee, Washington 98801

WWW.PACAERO.COM

TITLE:  
CONNECTOR, RF, LASER WELDABLE PUSH-ON (LLWP), HIGH PERFORMANCE,  
ALUMINUM COMPATIBLE

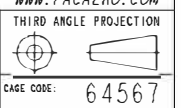

|         |               |
|---------|---------------|
| VERSION | RELEASE DATE: |
| - .2    | 01-23-07      |

SALES DRAWING

SHEET: 1 OF 1

DOCUMENT: 0-93843