



Modular Electric HMR Linear Drives

Assembly and Operating Instructions

aerospace
climate control
electromechanical
filtration
fluid & gas handling
hydraulics
pneumatics
process control
sealing & shielding



ENGINEERING YOUR SUCCESS.

Warranty

These operating instructions are subject to changes including changes in technical details with respect to the information and figures contained herein.

Parker-Hannifin GmbH grants no quality or durability guarantees nor any guarantees as to the suitability for specific purposes. Such guarantees must be expressly agreed upon in writing.

Public statements, recommendations or advertising do not in any way represent quality specifications.

The operator's warranty rights require that the operator immediately report any defects and precisely describe said defects in the complaint. Parker-Hannifin GmbH is not responsible under any circumstances for damage to the product itself or any consequential damage caused by the product resulting from improper handling of the product. If Parker-Hannifin GmbH is responsible for a defect, Parker-Hannifin GmbH shall be authorized, at its discretion, to undertake improvements or deliver replacements.

In compliance with ISO 9000, all HMR products are equipped with a type plate that is connected to an HMR unit. The type plate must not be removed or damaged under any circumstances.

Parker-Hannifin GmbH shall not be held liable, regardless of any legal basis, except for cases of intent or gross negligence; injuries to life, body or health; or defects of malicious nondisclosure or whose absence was expressly guaranteed in writing. Furthermore, if there is compulsory liability under the Product Liability legislation for personal injury and property damage to privately used objects, in the event of negligent breach of significant contractual obligations, Parker-Hannifin GmbH shall also be liable for cases of ordinary negligence; however, this is limited to damages that are contractually typical and foreseeable.

Further claims are hereby excluded.

Failure to adhere to these operating instructions or the relevant statutory provisions as well as any other information from the supplier shall invalidate the warranty.

In particular, we are not responsible for failures caused by modifications made by the customer or other parties. In such cases, the normal repair costs will be calculated. These costs will likewise be calculated for a check of the unit if no fault can be determined on the unit.

This regulation also applies during the warranty period.

No claims exist as to the availability of previous versions or to the retrofitting capacity of the units delivered to adapt them to the respectively current model version.

Copyright

The copyright to these operating instructions shall remain with **Parker-Hannifin GmbH**.

Copyright 2014©.

These operating instructions may not be reproduced or copied, either in full or in part, utilized for the purposes of competition without authorization, or distributed to third parties. Noncompliance could have legal consequences.

Product Monitoring

Our goal is to provide safe, state-of-the-art products. Therefore, we monitor our products on a continuous basis, even after delivery. Please notify us immediately of any recurring malfunctions or problems with the HMR.

Language of the Operating Instructions

For our international customers, these assembly and operating instructions are translated into various languages.

The German version is the original.

Other languages are a translation of the original operating instructions.

Section	Contents	Page
1	Foreword to the Operating Instructions	4
2	Safety	4
3	Product Information	5
	3.1 Scope of Application	5
	3.2 Type Plate	5
4	Application, Proper Use	6
	4.1 Prerequisite for Product Usage	6
	4.2 Conversions and Modifications	6
	4.3 Spare Parts and Accessories	6
5	Transportation and Storage	7
	5.1 Transportation	7
	5.2 Storage	7
6	Brief Description and Function	8
	6.1 General	8
	6.2 Setup and Mode of Action	8
	6.3 Profile versions and Carrier	8
	6.4 Profile versions	11
	6.5 Guide System	11
	6.6 Carriage	11
	6.7 Noise Emission	11
7	Assembly	12
	7.1 Important Information	12
	7.2 Installation of Linear Drive	13
	7.3 Attaching the Payload	16
	7.4 Cover for IP54	17
	7.5 Position Detection with Magnetic Switches	21
	7.6 Impact Protection	25
	7.7 Motor and Gearbox Mounting	26
8	Commissioning	30
	8.1 First Commissioning	30
	8.2 Operation	30
9	Maintenance and Repair	31
	9.1 Customer Service	31
	9.2 General Cleaning	31
	9.3 Lubrication Intervals	31
	9.4 Checking the Play of the Guide System	32
	9.5 Checking the Bearing Play	32
	9.6 Checking the Play in the Ball Screw Drive and Nut	32
	9.7 Check and adjust belt tensioning	33
	9.8 Checking the Cover Function	34
	9.9 Replacing the Carriage	35
	9.10 Replacing the Carriage	39
10	Decommissioning	44
	10.1 Disassembly of a Machine or System	44
	10.2 Disposal	44
11	Retrofit Kits	45
	11.1 IP54 Cover	45
	11.2 Position Detection internal and external	46
12	Spare Part / Wearing Part Kits	47
	12.1 Outer Band Package	47
	12.2 Outer Band	47
	12.3 Drive Type Ball Screw	48
	12.4 Carriage Belt Drive	49
	12.5 Carriage Ball Screw Drive	50
	12.6 Carriage Belt Drive	51
	12.7 Drive Shafts Belt	52
	12.8 Belt Tensioning Block	53
	12.9 Impact protection	54
13	Declaration of Incorporation	55

1 Foreword to the Operating Instructions

The operating instructions contain important information and assist in preventing hazards, repair costs and downtimes; they also increase the reliability and service life of the HMR.

Everyone that works with the HMR must read and adhere to the operating instructions, e.g.:

- Operation, including setup, fault elimination in the work sequence, handling and disposal of hazardous substances (operating materials and auxiliary materials)
- Maintenance (cleaning, maintenance, inspection, repair)

The information in these operating instructions, particularly the safety section, must be observed.











2 Safety

In addition to the operating instructions and the regulations regarding accident prevention and environmental protection that are applicable and mandatory in the country of use and at the site of use, the recognized technical regulations for safe and professional working must also be observed.

Explanation of symbols and notes

- ▶ This symbol is used as a handling prompt.
The symbol describes assembly steps, for example.

Notes that are identified with the following symbols assist in preventing risks to life and limb. Distribute this information to all users.

Example of Symbols	Explanation
	 DANGER Warns of personal injury that already exists at the moment of the warning
	 WARNING Warns of personal injury if there is improper handling or failure to comply with instructions
	 CAUTION Warns of potential personal injury of which workers should be aware
	 ATTENTION Warns of property damage or malfunctions.
	 NOTE Warns of potential worsening of results and/or provides tips.

Operator's obligation

The following are the obligations of the operator:

- Adherence to Machinery Directive 2006/42/EC.
- Adherence to the valid, national regulations on occupational safety.
- Proper use of the HMR.
- Adherence to the regulations in these operating instructions.

Operators

Operators for the overall system must ensure that the HMR is only operated by authorized and qualified personnel. Authorized personnel include trained specialists from the operator, from the manufacturer (Parker-Hannifin GmbH) and from an approved service partner.

Working in a safety-conscious manner

Check at reasonable intervals that personnel are working in a safety-conscious manner and adhering to the operating instructions.

3 Product Information

Designs

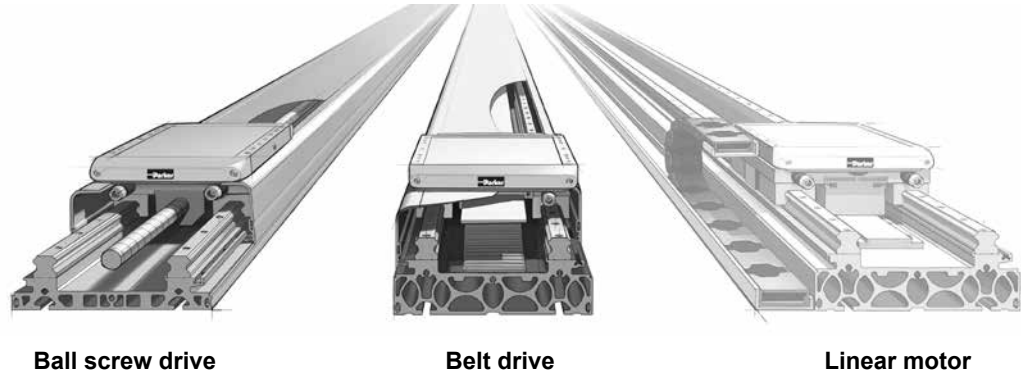

3.1 Scope of Application

The description in these operating instructions relates to the products.

3.1.1 Ball Screw Drive

Linear drive with ball screw drive and parallel guide

HMRS08
HMRS11
HMRS15
HMRS18
HMRS24



3.1.2 Belt Drive

Linear drive with toothed belt and parallel guide

HMRB08
HMRB11
HMRB15
HMRB18
HMRB24

3.2 Type Plate

The type plate is located on the HMR end cap drive end. A second plate has been enclosed.

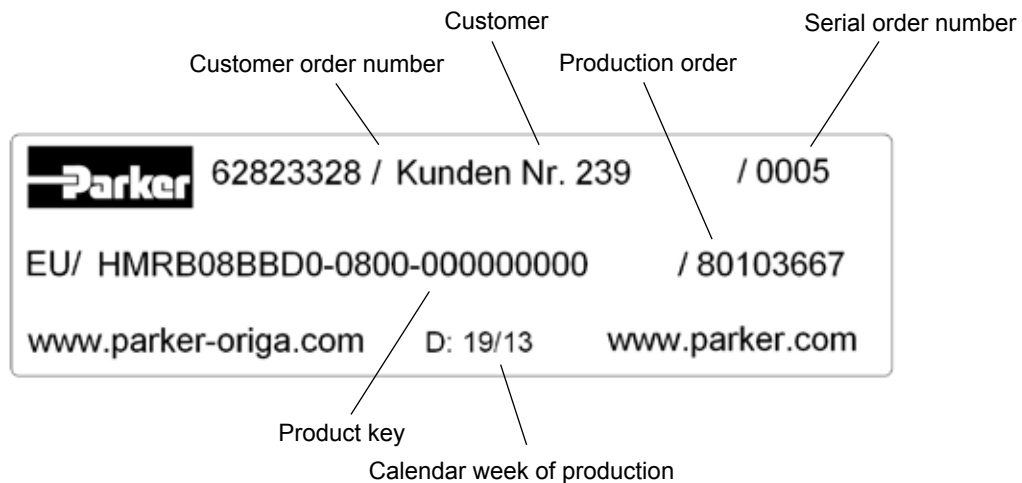

4 Application, Proper Use

The operational safety of the HMR is only ensured with proper use.

Proper use of the HMR only includes the following:

- Moving loads
- Positioning masses
- Exerting force

The HMR is driven with rotating or linear motors.

The catalog data and the conditions specified in the order confirmation must be taken into account. Please note the limits from the technical data and the corresponding characteristic curves as per the catalog information.

The values apply to continuous operation. With intermittent operation, the combination of speed and load may accommodate higher values for short periods. However, the individual maximum values indicated must not be exceeded.

If the HMR is used in any other manner, this does not constitute proper use.

Obvious misuse

Any use to transport persons or applications of any manner in the private sector (consumers) is not authorized. This may result in personal injury and damage to property. We shall accept no liability for any injury or damage resulting herefrom. The user shall bear sole responsibility and risk.

The following are not authorized:

- Unauthorized modifications to the HMR
- Processes that affect the safety of the HMR

Note all of the information attached to the HMR.

Keep this information in a fully legible condition.

In addition, note the manufacturer's information regarding lubricants, solvents and cleaning agents.

4.1 Prerequisite for Product Usage

The installation must always be carried out such that:

- The HMR is installed without delay
- All connections and control components are accessible
- The type plate with the product name remains legible
- The ambient conditions are maintained corresponding to design delivered (IP20 or IP54)

The operator must secure any hazardous sources that may result during installation in machines and systems between Parker-Hannifin products and customer equipment, according to CE conformity.

4.2 Conversions and Modifications

HMR linear drives may not be modified with respect to the design or safety-related features without the written approval of Parker-Hannifin GmbH. Any unauthorized modification in this respect will exclude any liability on the part of Parker-Hannifin GmbH.

If special attachments are to be used, the assembly regulations of the manufacturer must be observed.

The following also apply:

- Relevant accident prevention regulations
- Generally recognized safety rules
- EU directives
- Country-specific provisions.

4.3 Spare Parts and Accessories

Original spare parts and accessories authorized by the manufacturer are intended to protect your safety. The use of other parts could change the properties of the HMR.



We shall accept no liability for any resulting consequences.



5 Transportation and Storage



5.1 Transportation

The electric HMR linear drives are extremely precise products. Impacts could damage the mechanical system of the drive, resulting in a negative influence on functionality.

To prevent damage during transportation, place the units in appropriate protective packaging.



 WARNING	
Lifted or suspended loads can tip over or crash down.	
This could result in severe injuries or damage to property.	
	▶ Never walk under suspended loads.
	▶ Transport loads as close to the floor as possible.
	▶ Securely fasten the load for transportation and note the center of gravity.

 CAUTION	
Heavy parts can slip during handling!	
This could result in severe injuries or damage to property.	
	▶ Hold parts or units securely.
	▶ Wear safety gloves.
	▶ Use tools and supports.

 ATTENTION	
The profile may bend or snap!	
	▶ Support the drive profile appropriately during transportation and handling (e.g. with a bar).

Transport packed or unpacked HMR units using a crane or forklift

- In storage and handling static deflection of the actuator should not exceed 0.1% of total length.
- Larger deformations could result in a reduced service life, increased wear, and increased friction. These must therefore be avoided!
- Attach ropes as shown/use fork as shown.

 NOTE	
	Notify the shipping company and Parker-Hannifin GmbH or the delivery company immediately, in writing, of any transportation damage or missing parts.

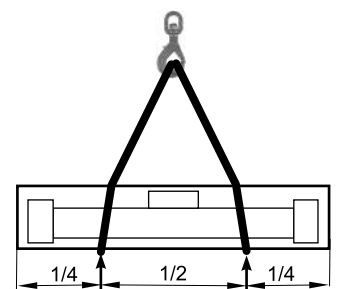

5.2 Storage

The storage location must be:

- Dry, free of dust and vibrations
- On a flat surface.

Deflection of the HMR must be avoided!

- Support the drive profile appropriately during transportation and handling.

6 Brief Description and Function

6.1 General

The **HMR catalog** contains extensive information on the following:

- Dimensions, space requirements
- Load-carrying capacity, forces and torques
- Weights and further technical data

The electric linear drives from the HMR series may only be operated within the permissible specifications.

We reserve the right to make technical changes.

6.2 Setup and Mode of Action

The electric HMR linear drives are used for the linear moving and positioning of an external payload. A combination of multiple linear drives allows the spatially oriented movements to be achieved. When the linear drive and the payload are in motion, a force is exerted in the direction of movement.

- A payload is fastened at the pre-existing threaded holes on the carriage.
- The carriage is connected to a Drive Type (screw, toothed belt) and is moved by this Drive Type.
- The carriage is mounted on a linear guide system in a movable manner; the linear guide system is fastened to the profile version.
- The profile version is fastened directly onto a substructure.
- The “reinforced” profile can also be used as a self-supporting structure. In doing so, attention must be paid to the permissible loads.
- A cover can be constructed on the linear drive to reduce the penetration and discharge of dirt or abrasion.
- Lubrication can be carried out during service as needed via external lubricating nipples.
- A position signal can occur through magnetic switches mounted on the inside or outside, which are switched by a magnetic package on the carriage.
- A displacement signal of the linearly moving carriage can be achieved by means of an installed displacement measuring system.

6.3 Profile versions and Carrier

A carriage is moved and force exerted through a rotational movement at the drive shaft.

- Temperature range: -20°C to +80°C
- Installation position: Any
- Humidity: Non-condensing.

Dimensions

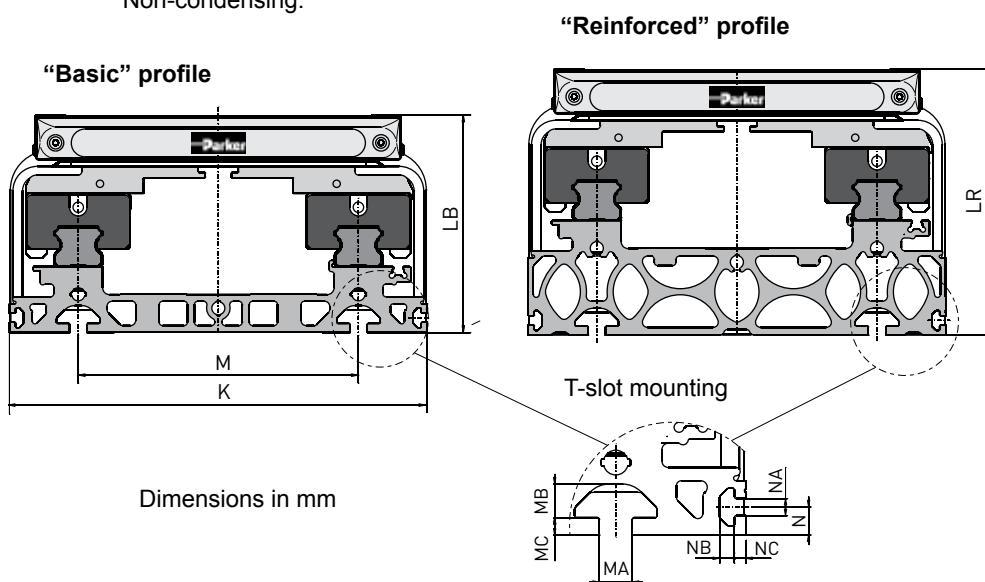

Dimension table – Profile versions

Series	K	LB	LR	M	MA	MB	MC	N	NA	NB	NC
HMRx08	85	60.0	71.0	50	5.2	4.5	2.5	4.5	3.4	3.0	2.5
HMRx11	110	69.5	89.5	70	5.2	4.5	2.8	4.5	3.4	3.0	2.5
HMRx15	150	90.0	114.0	96	6.2	6.8	3.0	6.5	5.2	4.6	3.5
HMRx18	180	111.5	134.5	116	8.0	7.8	4.5	8.5	5.2	4.5	3.5
HMRx24	240	125.0	153.0	161	10.0	10.2	5.3	8.5	5.2	4.5	3.5

6.3.1 HMRS Ball Screw Drive

A carriage is linearly moved by a rotating ball screw drive driven by the motor; the carriage is mounted on a guide system in a movable manner. The screw turns clockwise.

The load to be moved is fastened onto the carriage.

The permissible thrust force, speed and the linear displacement per rotation of the drive shaft depends on the design of the screw used.

The dimensioning is as per the ordering process (HMR catalogue)

- ES = Effective Stroke
- SS = Safety Stroke
- CD = Carriage distance
- CL_S = Carriage length Standard
- CL_L = Carriage length long
- S = Stroke
- OS = Order Stroke
- OAL = Over All Length

Standard design with one carriage

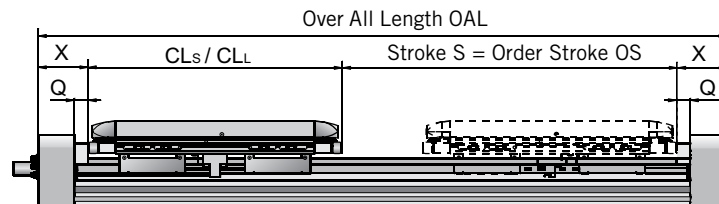

Order Stroke OS = Effective Stroke ES + 2 x Safety Stroke SS

Over All Length OAL = Order Stroke OS + Carrier Length CL + 2 x dimension end cap X

Tandem design with two carriages

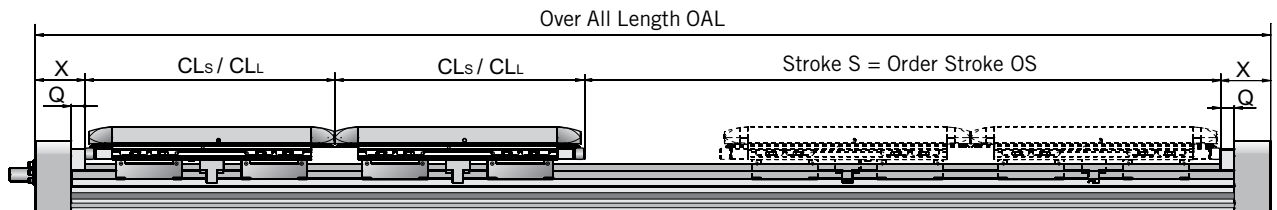

Order Stroke OS = Effective Stroke ES + 2 x Safety Stroke SS + Carriage distance CD

Over All Length OAL = Order Stroke OS + 2 x Carrier Length CL + 2 x dimension end cap X

Dimension table - Carriage and Over All Length HMRS

Product size	CL _S	CL _L	Q	X
HMRS08	195	in advance	16	54.0
HMRS11	225		20	65.0
HMRS15	266		20	62.0
HMRS18	311		20	66.0
HMRS24	371		20	73.0

Dimensions in mm

Modular Electric HMR Linear Drives

6.3.2 HMRB Belt Drive

A carriage is linearly moved by a toothed belt driven by the motor; the carriage is mounted on a guide system in a movable manner. The load to be moved is fastened onto the carriage.

The permissible thrust force, speed and the lead constant per rotation of the drive shaft depends on the design and on the toothed belt used.

The dimensioning is as per the ordering process (HMR catalogue)

- ES = Effective Stroke
- SS = Safety Stroke
- CD = Carriage distance
- CL_S = Carriage length Standard
- CL_L = Carriage length long
- S = Stroke
- OS = Order Stroke
- OAL = Over All Length

Option Carrier Standard

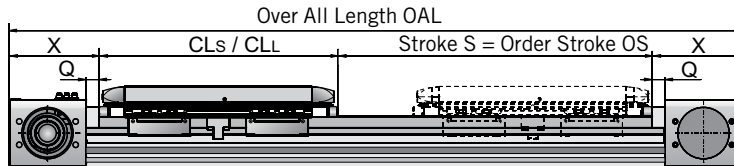

Order Stroke OS = Effective Stroke ES + 2 x Safety Stroke SS

Over All Length OAL = Order Stroke OS + Carrier Length CL + 2 x dimension end cap X

Option Carrier Tandem

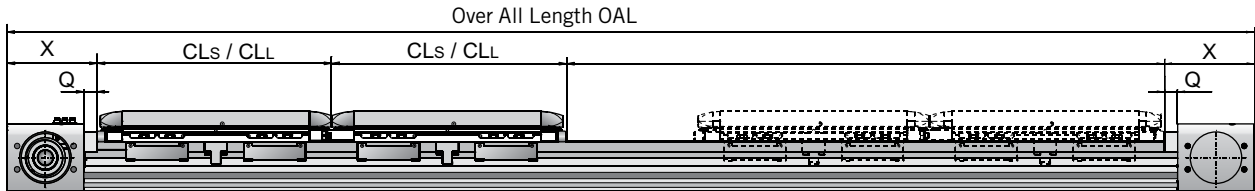

Order Stroke OS = Effective Stroke ES + 2 x Safety Stroke SS + Carriage distance CD

Over All Length OAL = Order Stroke OS + 2 x Carrier Length CL + 2 x dimension end cap X

Option Carrier Bi-part for opposite movements

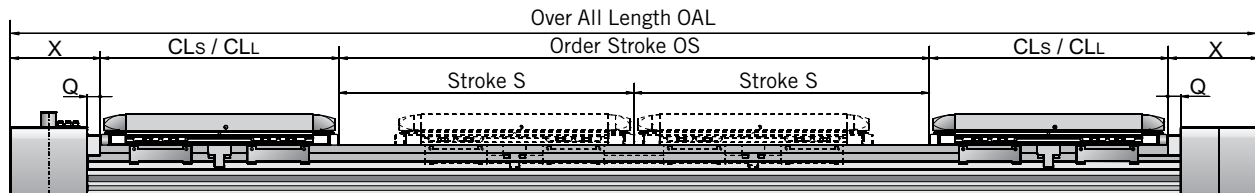

Order Stroke OS = 2 x Stroke S = 2 x Effective Stroke ES + 4 x Safety Stroke SS + Carriage distance CD

Over All Length OAL = Order Stroke OS + 2 x Carrier Length CL + 2 x dimension end cap X

Dimension table - Carrier and Over All Length HMRB

Product size	CL _S	CL _L	Q	X
HMRB08	195	in advance	16	74
HMRB11	225		20	85
HMRB15	266		20	110
HMRB18	311		20	120
HMRB24	371		20	140

Dimensions in mm

6.4 Profile versions

The user must fasten the profile version onto the corresponding substructure.

The linear drive can easily be aligned with the assistance of a reference edge machined on one side.

	NOTE
	The stop edge is equipped with a groove.

Designs:

“Basic” Profile

For assembly on a continuous substructure.

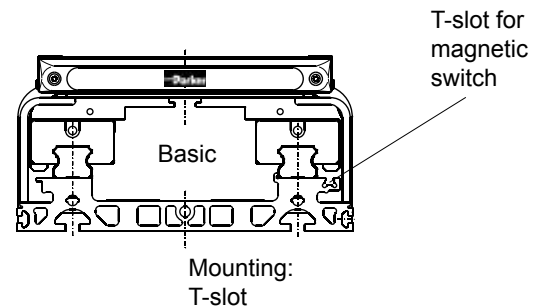

“Reinforced” profile

For an extensively self-supporting substructure.

Due to the reinforced profile geometry, and the resulting inherent stiffness, resistance to deflection of twist is increased.

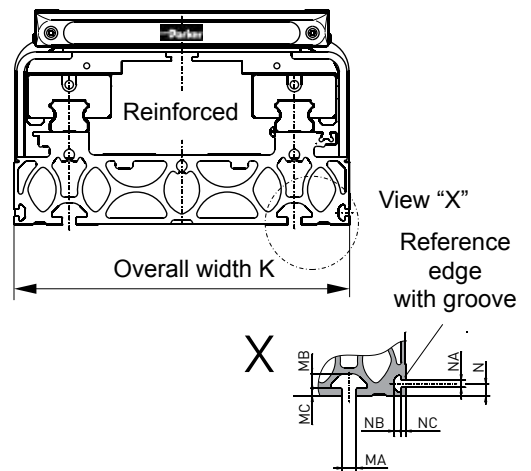

6.5 Guide System

The guide system is mounted onto the profile version. It accommodates the static and dynamic loads from the externally moving load as well as the external forces. The permissible load data must not be exceeded.

Ball bearing guide

Runner blocks with balls are moved linearly on a precision guide rail made of steel.

The maintenance schedule recommended by Parker Hannifin in section 9 must be followed.

6.6 Carriage

The carriage moves an externally connected load in a linear fashion. The external load may only be fastened at the pre-existing threaded holes. Following **versions**:

Standard carriage

A carriage that is connected to the drive type (figure).



Tandem carriage

Includes a second carriage that can be freely moved on the guide system.

The external load is distributed onto two carriages that are mounted at a fixed distance, facing one another.

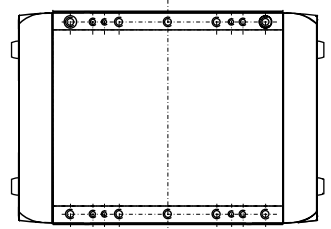

Carriage Bi-part “Bidirectional”

(only HMRB, belt, motor mounting position AP, CP, AD, CD)

With a second carriage that is driven from the belt in the opposite direction to the first carriage.

6.7 Noise Emission

Depending on the drive types, guide system, load and speed, noise emissions of varying intensities result, which are constrained by the setup. The operator is responsible for adhering to the applicable provisions and regulations.

7 Assembly



7.1 Important Information

HMR installation, and all other installations, may only be carried out by trained mechanical technicians or electricians. The information in these instructions must be strictly observed.

Tightening torques for screws

Thread	Tightening torque	Tolerance
M3	1.2 Nm	± 0.2 Nm
M4	3 Nm	± 0.5 Nm
M5	5.5 Nm	± 0.8 Nm
M6	10 Nm	± 1.5 Nm
M8	20 Nm	± 3 Nm
M10	40 Nm	± 6 Nm

Remarks regarding use and operation:

	ATTENTION
	Excessive forces or loads
	Overload of the HMR would be possible
	▶ Adhere to catalog data.

Mechanical

Additional drill holes or other machining may not be implemented on the HMR!

- ▶ Only attach the payload **at the threaded holes on the carriage** in section 7.3.
- ▶ Adhere to the permissible load limits such as weight, speed and acceleration.
- ▶ Adhere to the permissible load limits such as weight, speed and acceleration.

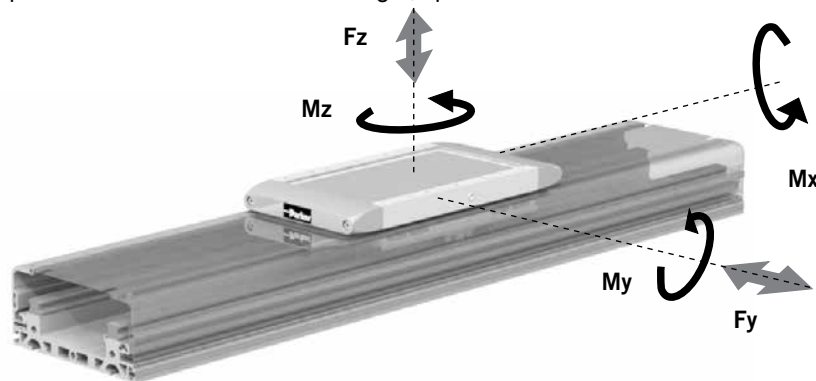

Combined loads

The maximum permissible load for linear drives subject to simultaneous multiple loads, forces and bending moments are calculated using the formula below. Maximum permissible loads must not be exceeded.

$$L = \frac{F_y}{F_{y(max)}} + \frac{F_z}{F_{z(max)}} + \frac{M_x}{M_{x(max)}} + \frac{M_y}{M_{y(max)}} + \frac{M_z}{M_{z(max)}} \leq 1$$

The sum of all loads must under no circumstance be > 1.

Take note of the additional information in the Parker HMR **catalogue** on the “**Maximum permissible load**” on page 7.

Electrical information

- ▶ The controller, motor, position detection and all other necessary electrical elements must be connected according to technical rules, within the responsibility of the operator.
- ▶ Do not place magnetic switches in the vicinity of ferritic parts or moving loads.
- ▶ Only use the seating grooves and/or the mounting holes on the aluminium profile for the assembly and mounting of the profile version, as described in detail in the HMR catalog.

7.2 Installation of Linear Drive

All installation measurements can be found under “6.3 Carrier profile and drive body” on page 8 and in the HMR catalogue.

- ▶ During assembly, the HMR must be sufficiently supported and securely placed in a machine/system.

	ATTENTION
	Straightness tolerance exceeded
	The screw-on surface is important!
	▶ Ensure evenness and straightness.

The maximum straightness and evenness in the running direction of the linear system can only be achieved if the corresponding mounting points or surfaces are within the required tolerance.

The mounting surface for the profile version must have evenness of at least 0.2 mm/m at the clamping points.

	NOTE
	▶ Adhere to the tightening torques for screws according to section 7.1. on page 12.



7.2.1 Mounting with T-slots

- ▶ Use of T-slot profiles. Mounting from below.

Standard screws and sliding blocks or rails from the common profile systems can be used.

Mounting parts such as sliding blocks are available as accessories.

- ▶ Please observe the required number of T-sliding blocks in accordance with the axial holding force for secure assembly (see table below and HMR catalogue page 38).

HMRS



HMRB

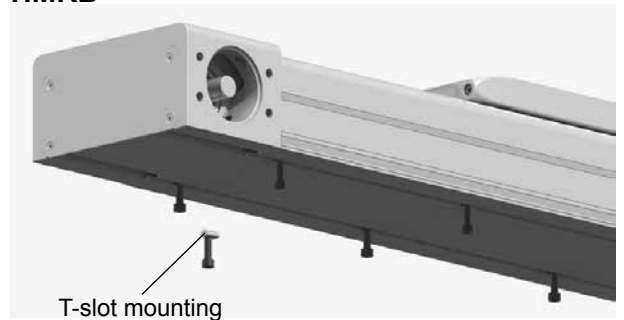

Max, axial holding force per mounting set

Product size	T-slot mounting	min, number of sets required per meter			
	[N]	horizontal	horiz, side	over head	vertical
HMRx08	1,000	4	11	19	5
HMRx11	1,000	4	11	19	5
HMRx15	1,600	4	5	10	5
HMRx18	2,700	4	5	10	5
HMRx24	3,200	4	4	8	5

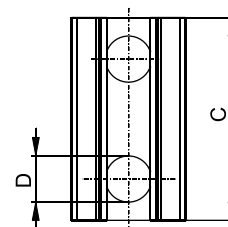

Dimension table - T-slot mounting HMR

Product size	A	B	C	Ø D	M	N	Order no.
HMRx08	8.0	4.0	11.5	M5	5.0	0.5	56351FIL
HMRx11	8.0	4.0	11.5	M5	5.0	0.5	56351FIL
HMRx15	10.5	6.4	22.5	M6	6.4	0.6	56351FIL
HMRx18	13.5	6.7	22.5	M8	8.5	1.0	56352FIL
HMRx24	16.5	8.9	28.5	M10	10.5	1.0	56353FIL

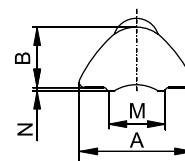

Modular Electric HMR Linear Drives

7.2.2 Mounting with T-slot fixture

- Use of the side T-slot profile. Screwing direction downwards.

Clamps can be supplied as accessories, see Parker **HMR catalogue** from page 38.



i	NOTE
	► Adhere to the tightening torques for screws according to section 7.1 on page 12.

- Please observe the required number of T-sliding blocks in accordance with the axial holding force for secure assembly (see table below and HMR catalogue page 38)

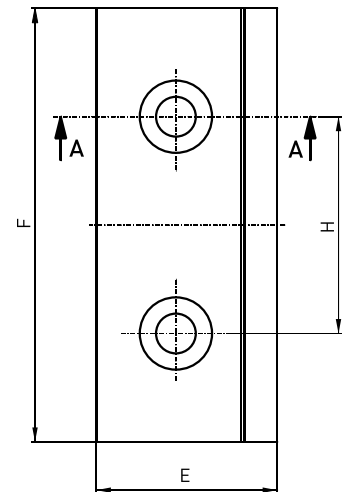
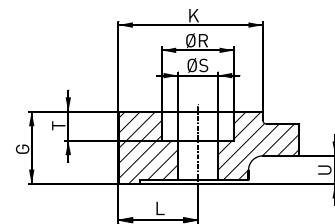
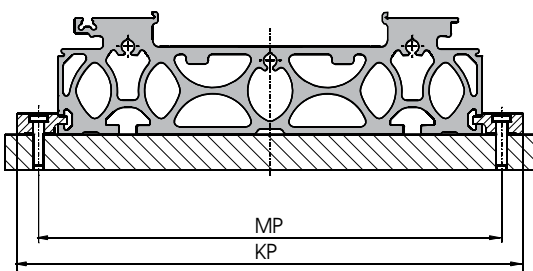
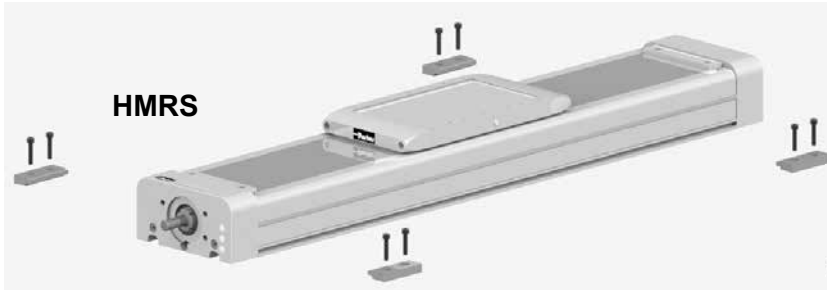

Max. axial holding force per fixing pair

Product size	T-slot fixture	min. number of sets required per meter			
	[N]	horizontal	horiz. side	over head	vertical
HMRx08	800	3	6	10	4
HMRx11	800	3	5	9	4
HMRx15	1,820	3	4	6	4
HMRx18	2,610	3	4	5	4
HMRx24	2,610	3	4	5	4

Dimension table - T-slot fixture

Product size	E	F	G	H	K	KP	L	MP	Ø R	Ø S	T	U	Order no.
HMRx08	18	40	7.5	20	15	115	9	97	0.0	4.5		2.8	56363FIL
HMRx11	18	40	7.5	20	15	140	9	122	0.0	4.5		2.8	56363FIL
HMRx15	25	60	10.0	30	20	190	10	190	10.0	5.5	4.0	3.9	56355FIL
HMRx18	28	80	12.0	40	23	226	12	226	11.0	6.6	4.7	5.9	56356FIL
HMRx24	28	80	12.0	40	23	286	12	286	11.0	6.6	4.7	5.9	56356FIL

7.2.3 Distance between supports

Distance between supports Fy

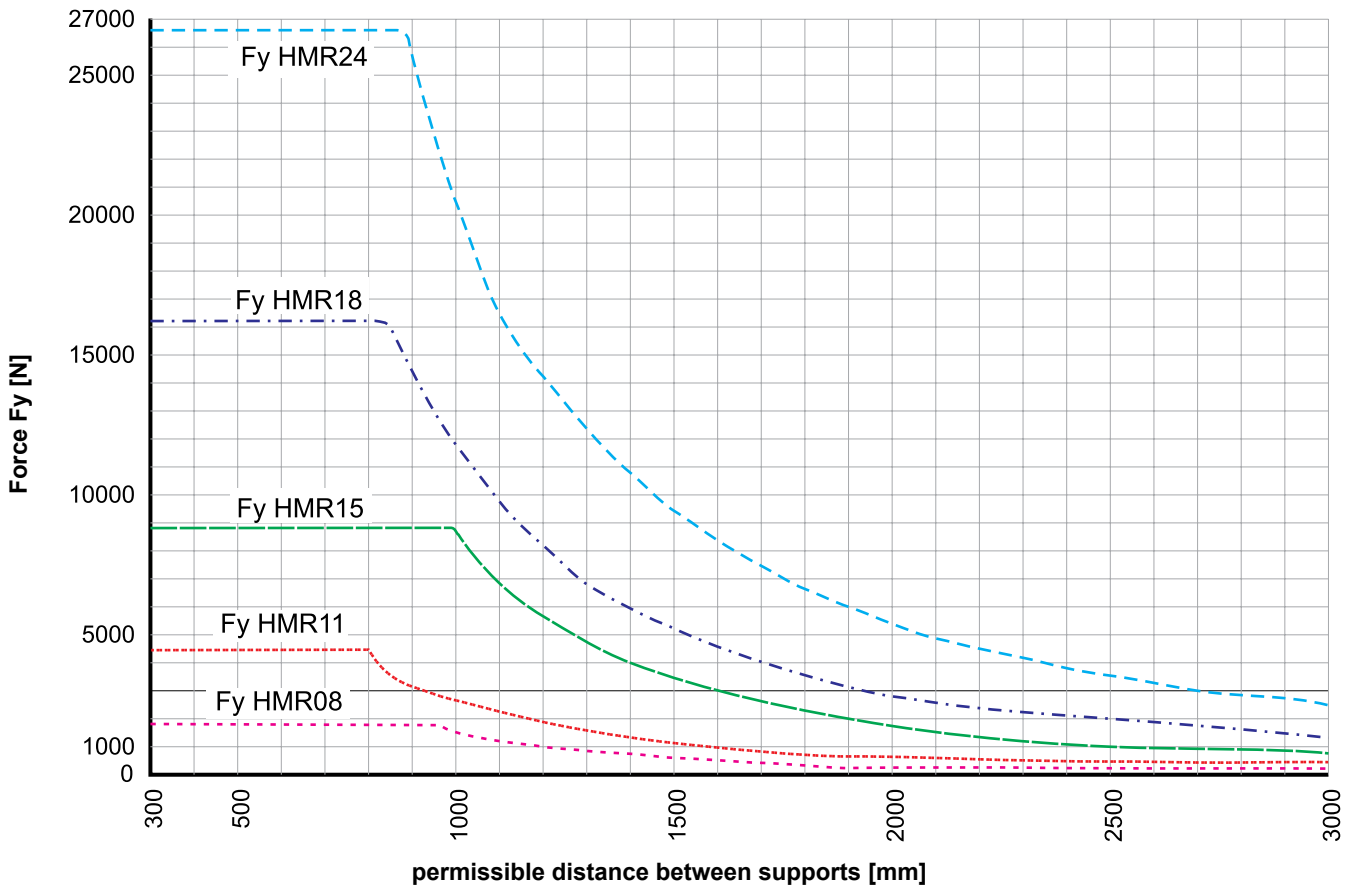

Distance between supports Fz

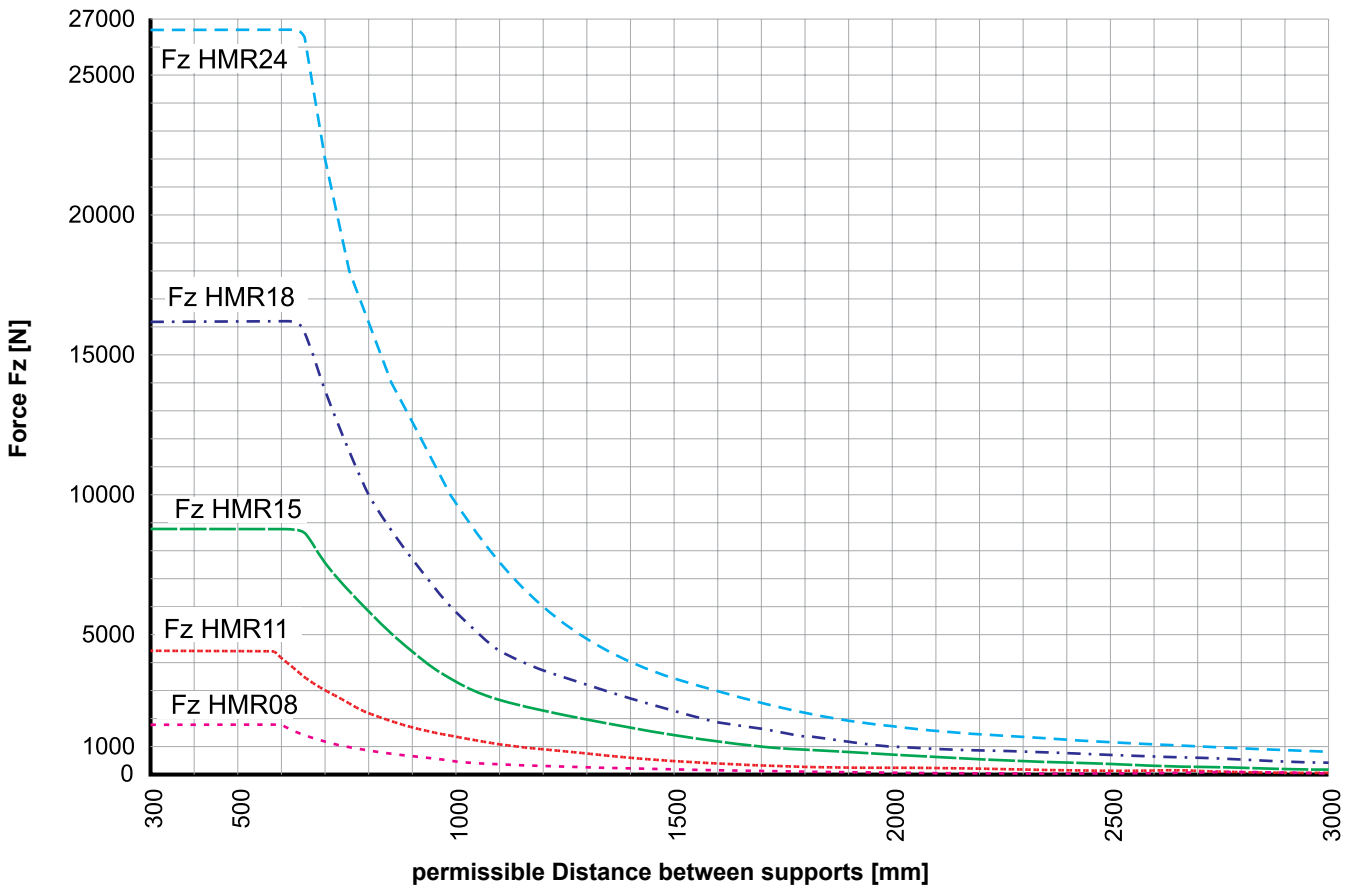

Modular Electric HMR Linear Drives

7.3 Attaching the Payload

The user is responsible for the use of the HMR and makes decisions on the attachment of loads as well as the operating status with speed, acceleration and frequency of movements. The HMR may only be installed according to the catalog's specifications.

	WARNING
	Danger due to fracture or deformation of components, incorrect arrangement of loads and crashing of loads
	This could result in severe injuries and damage to property.
	<ul style="list-style-type: none"> ▶ Attach components according to technical rules. ▶ Move heavy parts with a hoist; wear safety gloves. ▶ Observe HMR catalog data with respect to arrangement.

There are various threaded holes on the carriage available to the user of the HMR for mounting the payload.

	ATTENTION
	Risk of damage to the carriage
	Additional holes will weaken or damage important components and are not permitted.
	<ul style="list-style-type: none"> ▶ Do not drill or counter bore. ▶ Distribute load forces as required.

	NOTE
	▶ Adhere to the tightening torques for screws according to section 7.1 on page 12.

The carriage has two dowel holes into which dowel sleeves can be inserted. This makes it possible to repeat the disassembly/assembly of the payload without realignment.

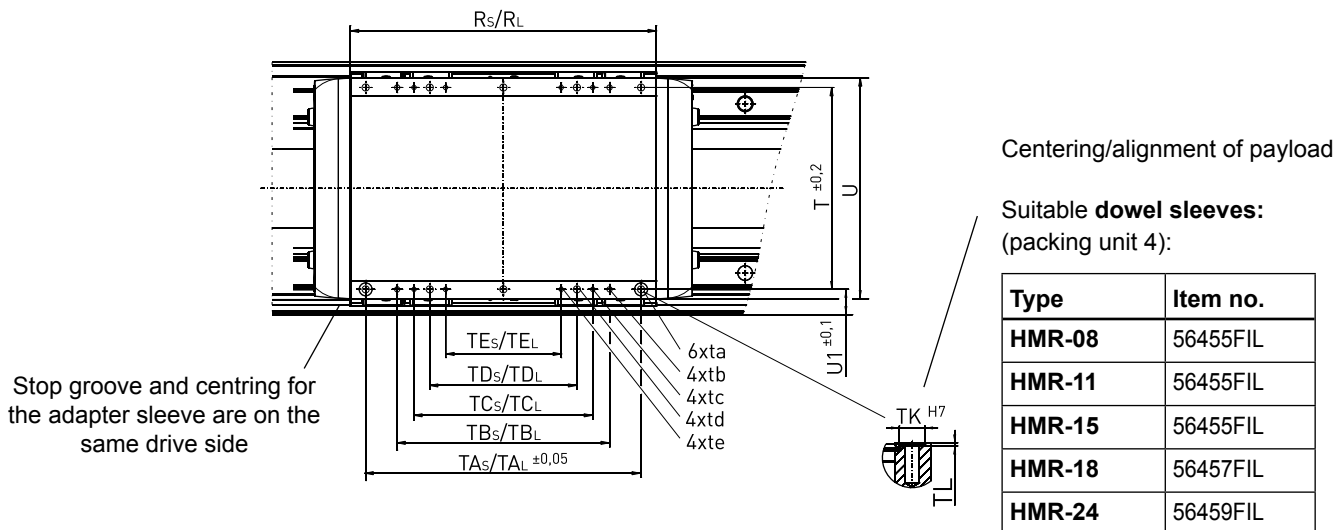

Centering/alignment of payload

Suitable **dowel sleeves:**
(packing unit 4):

Type	Item no.
HMR-08	56455FIL
HMR-11	56455FIL
HMR-15	56455FIL
HMR-18	56457FIL
HMR-24	56459FIL

Dimension table - Carriage length Standard HMRS

Type	R _S	R _L	T	TA _S	TA _L	ta	TB _S	TB _L	tb	TC _S	TC _L	tc	TD _S	TD _L	td	TE _S	TE _L	te	TK ^{H7}	U	U1
HMRS08	128	-*	74	97	-*	M4x12	70	-*	M4x12	40	-*	M4x12	-	-*	-	-	-*	-	7	83	5,5
HMRS11	150	-*	96	122	-*	M5x12	97	-*	M5x12	65	-*	M5x12	25	-*	M5x12	-	-*	-	7	105	7,0
HMRS15	191	-*	120	170	-*	M5x12	122	-*	M5x12	-	-*	-	70	-*	M5x12	-	-*	-	7	135	15,0
HMRS18	231	-*	150	202	-*	M6x12	170	-*	M5x10	122	-*	M5x10	90	-*	M6x12	-	-*	-	9	165	15,0
HMRS24	291	-*	192	262	-*	M8x16	202	-*	M6x12	170	-*	M5x10	140	-*	M8x16	122	-*	M5x10	12	210	24,0

* in advance

7.4 Cover for IP54

It is also possible to install various assemblies and equipment as a retrofit.
When doing so, remove the cover as necessary.

HMRS

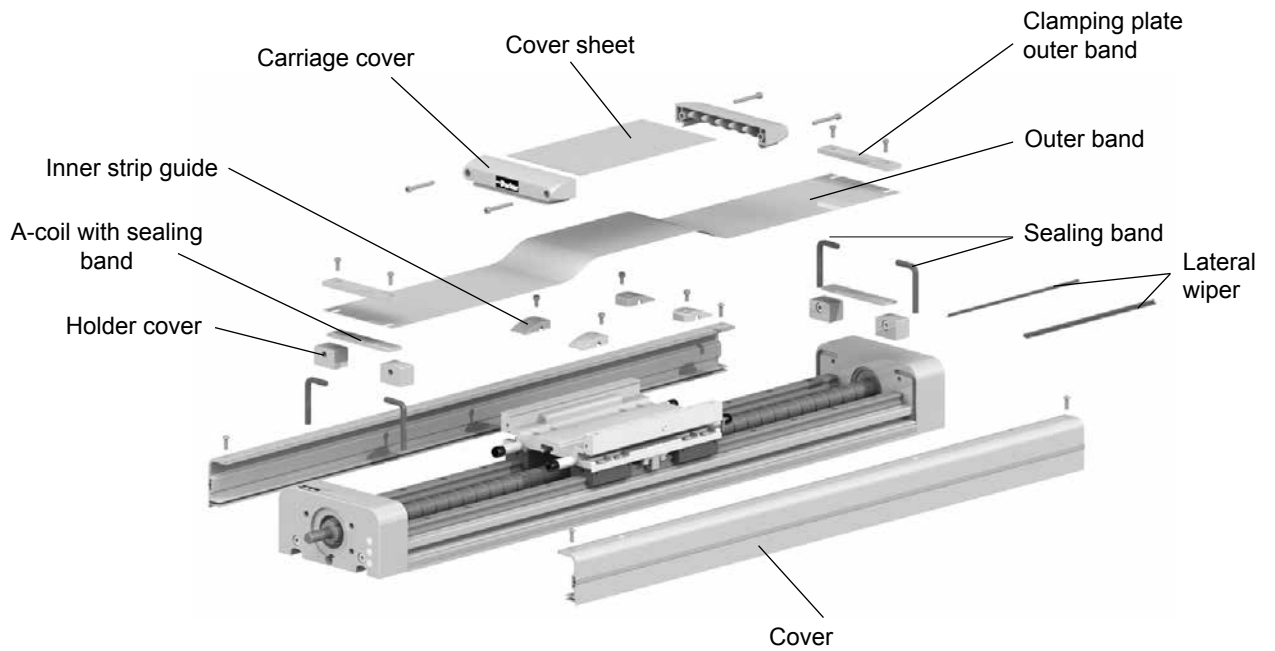

HMRB

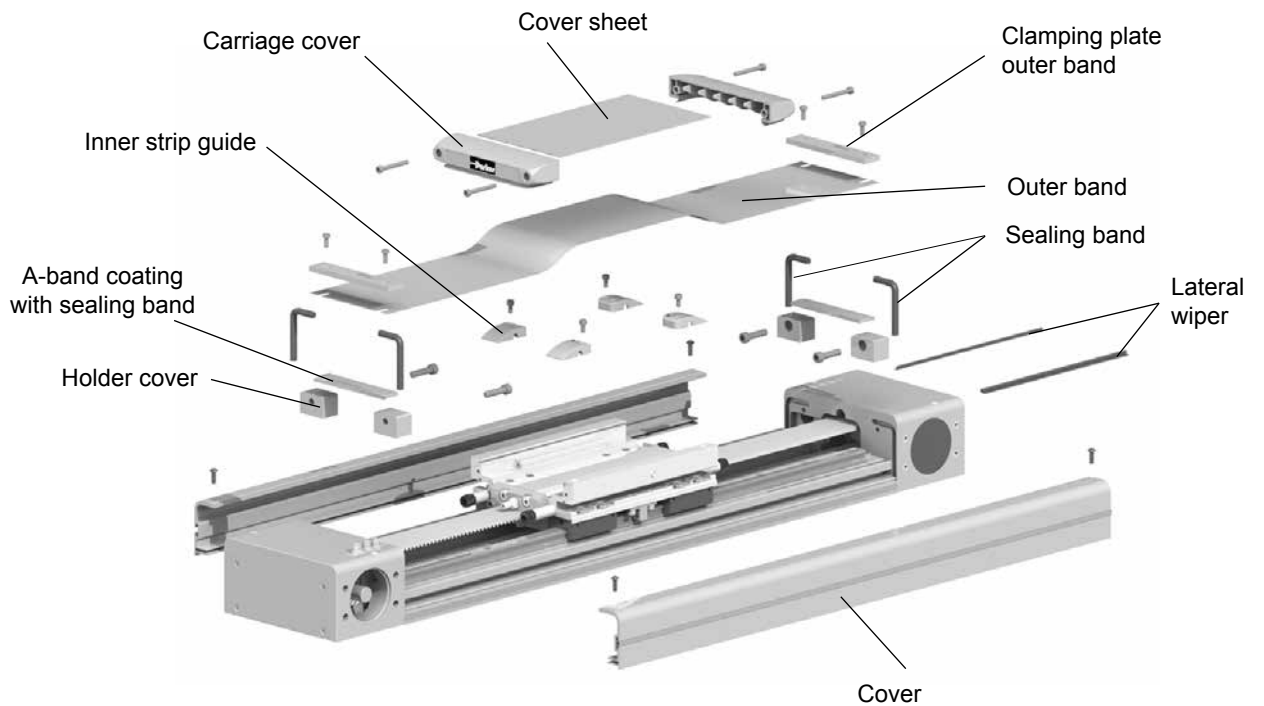

Modular Electric HMR Linear Drives

For HMR installation, maintenance purposes or conversion:

7.4.1 IP54 Cover Disassembly

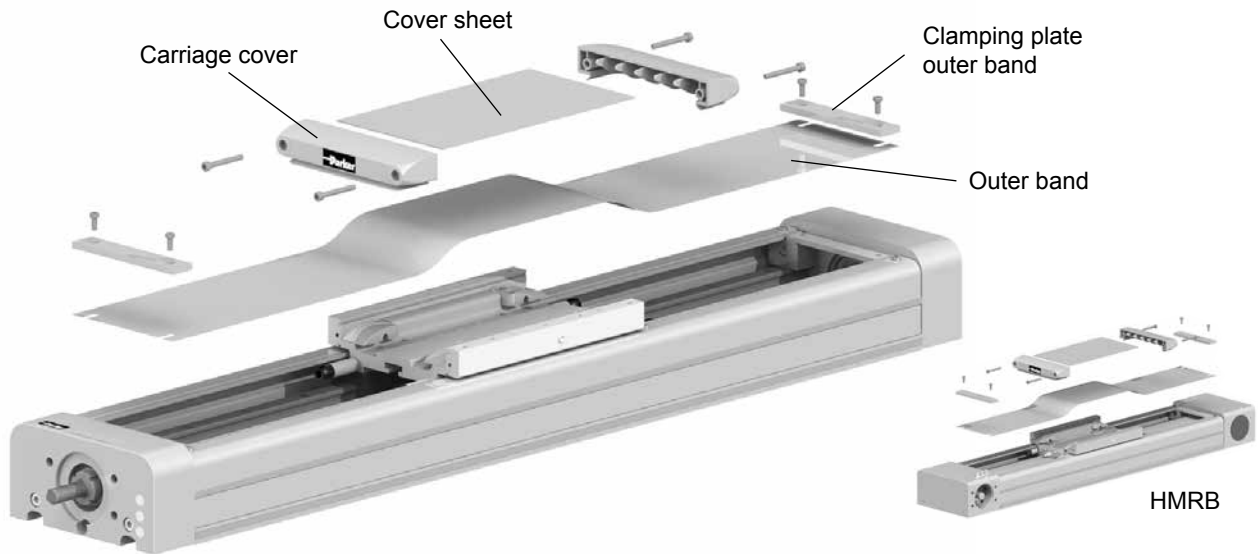

- ▶ Remove the **clamping plate** of the **outer band** on the end caps.
- ▶ Disassemble the **carriage cover**.
- ▶ Push the **cover sheet** out of the grooves.
- ▶ Remove the **outer band**.

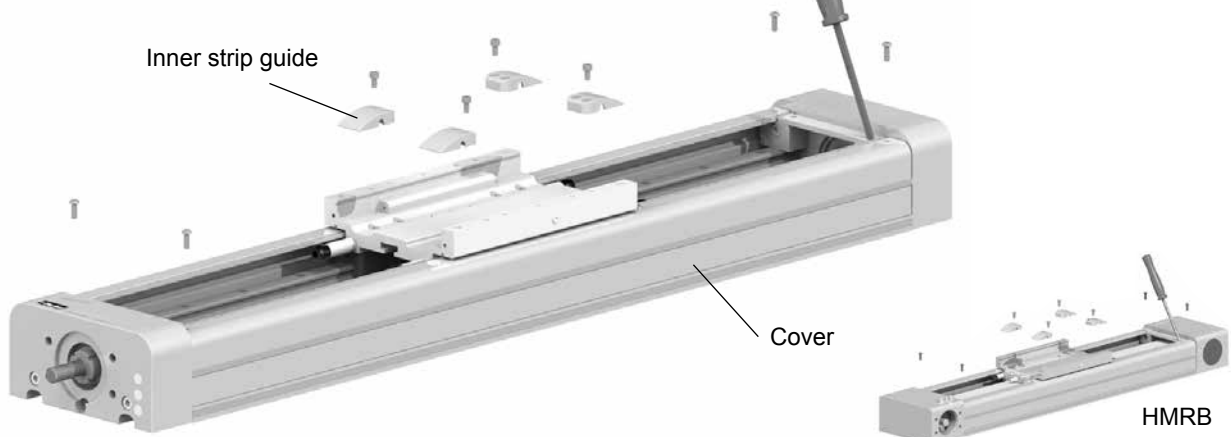

- ▶ Detach the **inner strip guide**.
- ▶ Unscrew the lateral **covers**.
- ▶ Only HMR08, 11: Loosen the fastening screws with slot nuts and remove the cover
- ▶ Only HMR15, 18, 24: To loosen the **covers**, lever one end with a screwdriver from the inside.

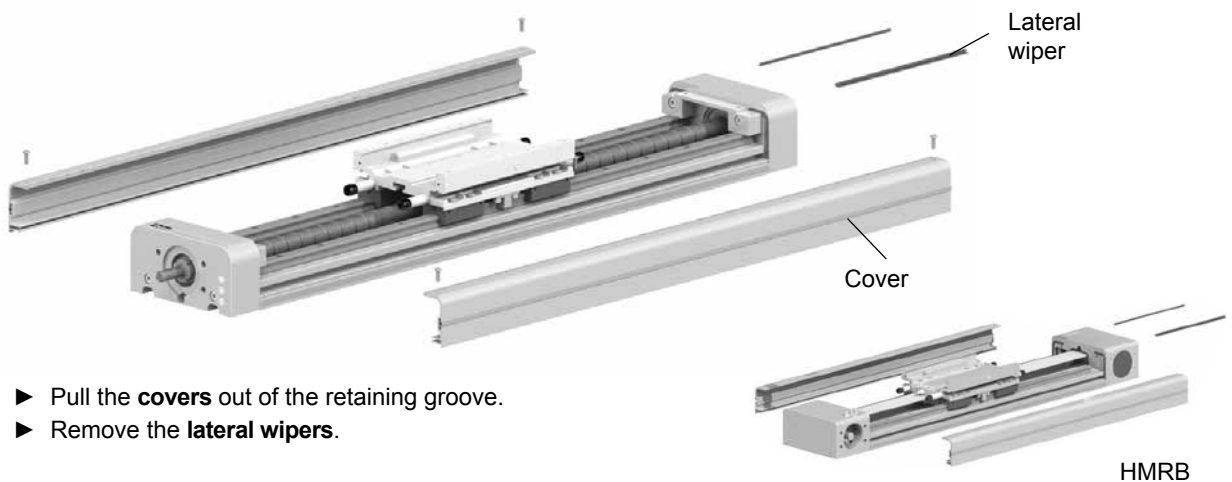



- ▶ Pull the **covers** out of the retaining groove.
- ▶ Remove the **lateral wipers**.

7.4.2 IP54 Cover Assembly

The cover can be retrofitted; refer to section 11.1. on page 45.

The following instructions also apply to retrofitting, converting or maintaining the HMR.

For information on necessary disassembly, refer to section 7.4.1 on page 18.

ATTENTION	
	It is possible to implement an incorrect assembly sequence.
	The cover covers the limit switches on the inside.
	<ul style="list-style-type: none"> ▶ Pay attention to the sequence! Make sure you differentiate between <ul style="list-style-type: none"> - HMR installation - Subsequent assembly of the cover and - Maintenance of the HMR

Assemble holder cover

- ▶ Insert the **CORDS** to seal the covers in the grooves on the cover.
- ▶ Place the **holder cover** on the guide rails 4x and screw these against the cover.

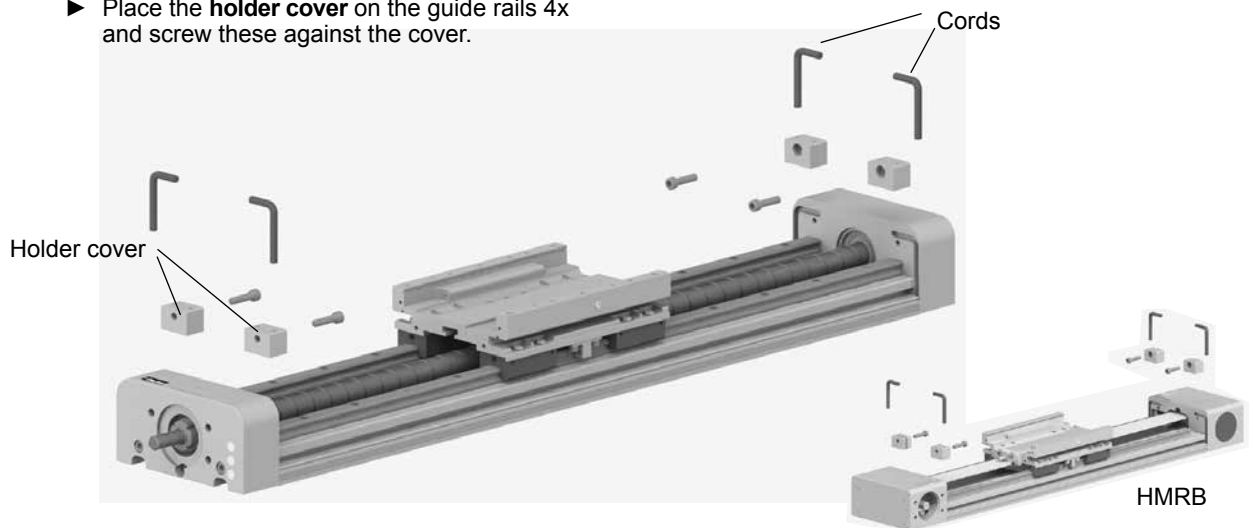

Mount the strip guides and side covers

- ▶ Screw 4x **inner strip guides** onto the carriage and grease lightly.
- ▶ Only HMR15, 18, 24: Push the **covers** into the longitudinal grooves on the carrier (clip in) and screw in the four **fastening screws**.
- ▶ Only HMR08, 11: Use **slot nuts** (number corresponding to the stroke length) and screw in the four **fastening screws**.

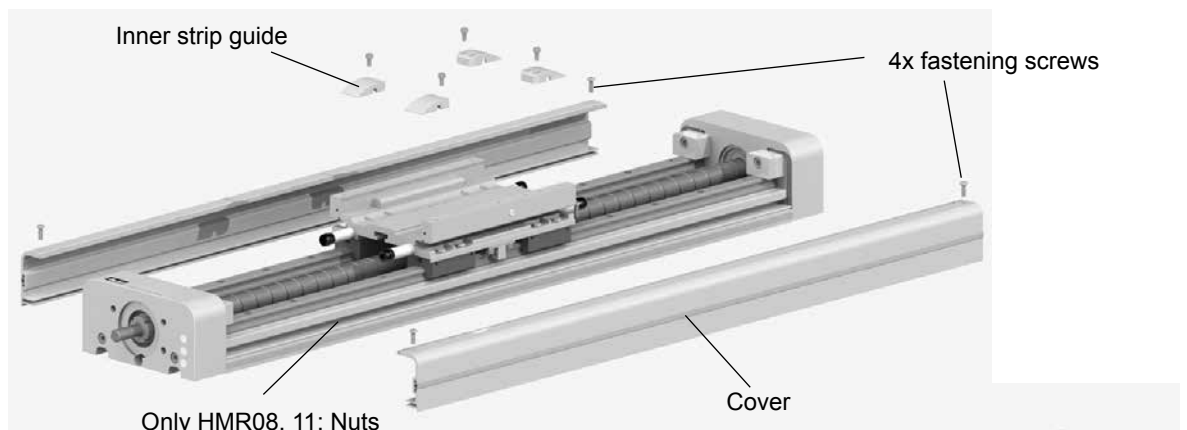

NOTE	
	▶ Adhere to the tightening torques for screws according to section 7.1 on page 12.

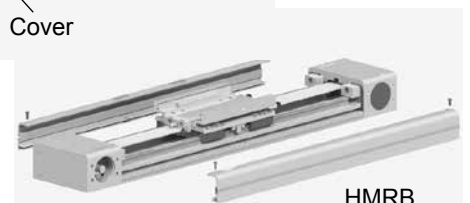

Modular Electric HMR Linear Drives

Mount the wipers and outer band

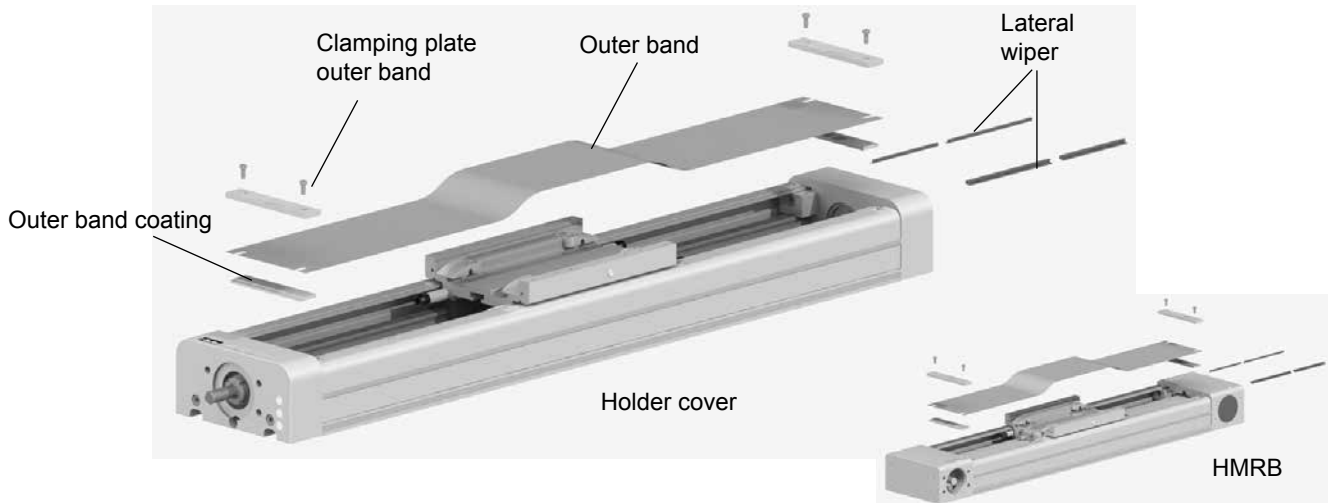

- ▶ Insert the **lateral wipers** into the grooves on the carriage. Pay attention to the alignment (lips should be facing outward).
- ▶ Place both **A-band coatings** on the holder cover. With this the sealing strips are visible and are on the covers in each case.
- ▶ Place the **outer band** onto the center of the HMR.

	ATTENTION
	Premature wear of the Outer band
	Twisted/distorted installation of the Outer band ▶ Careful tightening of the clamping strip - Outer band not twisted - Install without forming any ripples.
	NOTE
	▶ Adhere to the tightening torques for screws according to section 7.1 on page 12.

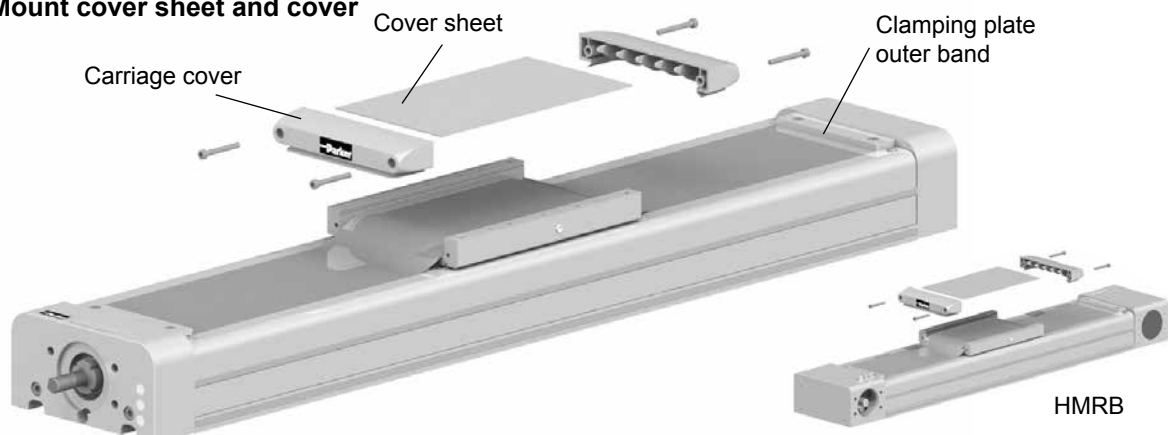

- ▶ On one side, tightly clamp the **outer band** with the **clamping plate** and screw on.

Mount cover sheet and cover



- ▶ Lightly grease the bottom of the carriage **cover sheet**.
- ▶ On one side, insert the **cover sheet** into the groove of the carriage.
- ▶ Only **HMR08, 11**: push the **side cover** from the front into the grooves of the carriage.
- ▶ Only **HMR15, 18, 24**: Lock the **side cover** into position by applying central pressure from above onto the opposite side. Note the correct position of the sealing strip in the carriage groove.
- ▶ Align the **carriage cover** on the carriage and screw down tightly.
The outer band must have contact with the entire profile length without any ripples.
- ▶ Tightly clamp the **outer band**, without any tension, to the second **clamping plate**.

7.5 Position Detection with Magnetic Switches

	ATTENTION
	Potential damage to equipment!
	<p>Missing or incorrect signals from the end position switches in the controller.</p> <p>► Essentially, clamp and set up end switches before commissioning!</p>

7.5.1 Definition

End position switch

The use of end position switches is highly recommended for operating electric linear drives to prevent mechanical damage in the end positions. End position switches must be implemented in the NC (normally closed) function so that any cable breaks can be detected by the controller.

Homing switch

In addition to the end position switches, a homing switch can be used to assign a repeatable zero point to the linear system. Homing switches are normally implemented in the NO (normally open) function. In this process, the homing switch must be between the end position switches.

Switch types

The magnetic switches described in the following can be used as switches. The switch function is triggered by the magnetic package mounted under the carriage. The user can use mechanical switches, proximity sensors etc. in the same manner.

SS = Safety Stroke
ES = Effective Stroke

Setting up switch points

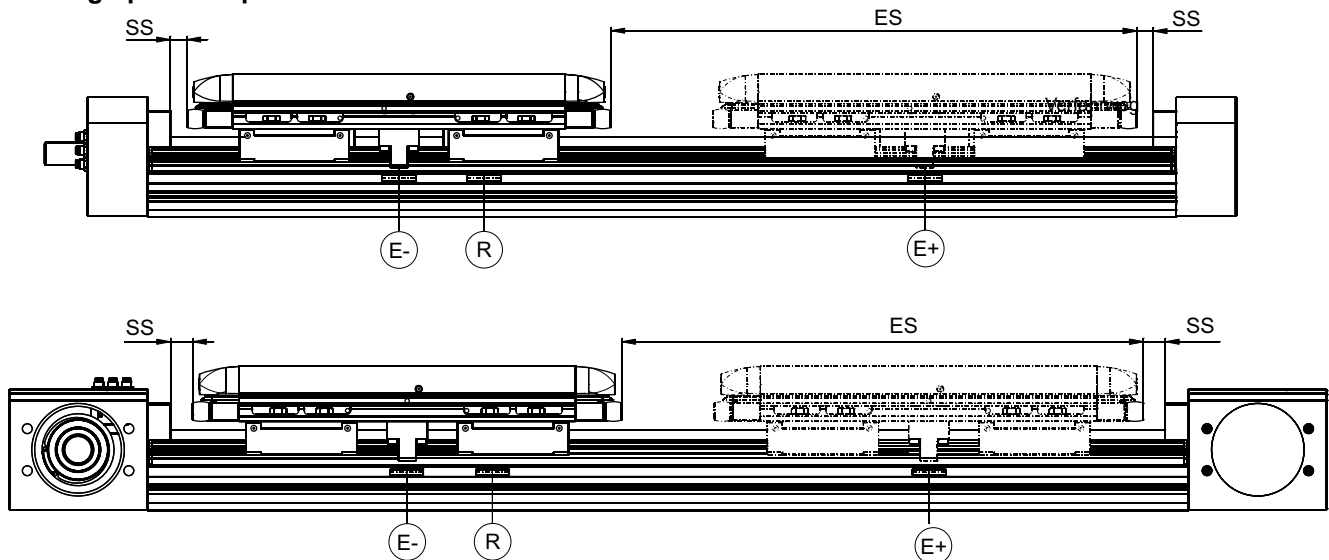

The switch point for the end position switches must be selected on both sides of the linear drive so as to ensure braking of the payload up to a standstill (depending on the motor system used) within the safety distance and at any time during operation. Depending on the application, the homing switch can be set up anywhere between the end position switches. If the switch points are not indicated when ordering, the user must carry out the alignment as well as the connection of the magnetic switches.

	NOTE
	Essentially, the user is responsible for checking each linear drive for proper setup and the function of the magnetic switches.

Example: Product code with digit in bold which displays the position of the safety distance
HMRxxxx-xxxx-xxxx**2**xxxx => **2 = 20 mm safety distance.**

Modular Electric HMR Linear Drives

7.5.2 Magnetic Switch Types

Electrical connection: cable type RST-K

Reed 2-pole

Closing function
(normally open)

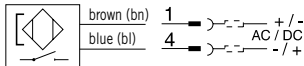

Opening function
(normally closed)

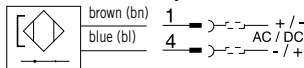

Electrical connection: cable type EST-K

PNP 3-pole

Closing function
(normally open)

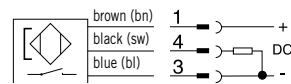

Electrical connection: plug type RST-S

Reed 2-pole

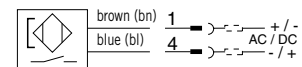

Typ EST-S

PNP 3-pole

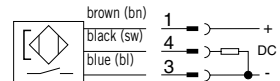

7.5.3 Connection Assignment for M8 Connector

The connector assignment complies with DIN EN 50044

3-pin connector assignment

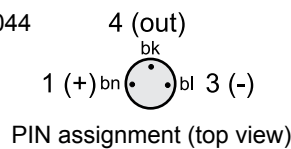

7.5.4 Installation of terminal block and M8 connectors

The IP54 cover must be opened as per section 7.4.1.

Mounting the M8 connectors in the end cap

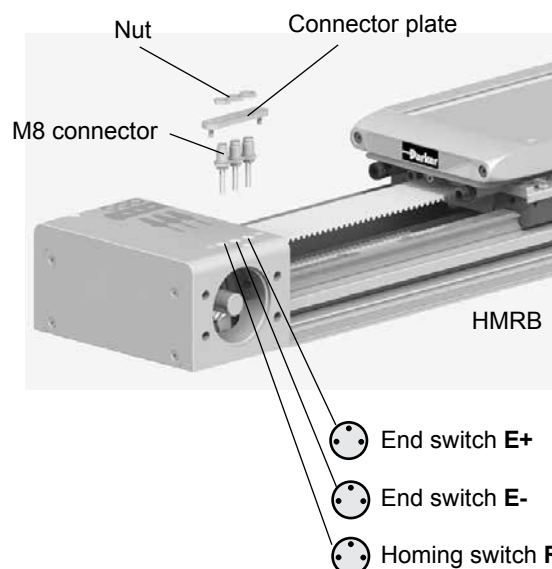
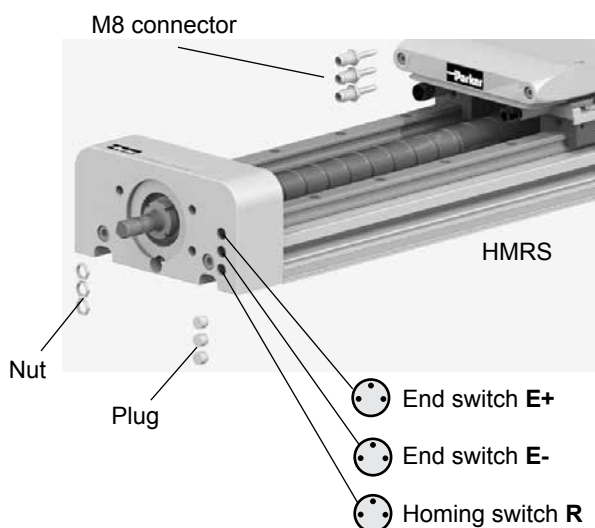

- ▶ Remove the **plugs** from the end cap.
- ▶ Insert the **M8 connectors** through the hole, starting from the back of the end cap drive end side, and secure with **nuts**.
- ▶ Solder the respective wire ends (use the heat shrink tubing).

- ▶ Remove the **connector plate** and corresponding **plugs**.
- ▶ Fasten the **M8 connector** to the **connector plate** with the **nuts**.
- ▶ Pass the cable through clearance.
- ▶ Fasten **connector plate**.

7.5.5 Setting up the Internal Magnetic Switches

The IP54 cover must be opened as per section 7.4.1 on page 18.

Tip: Adjust the carriage to the desired position (end position/homing) and then move the magnetic switch in the T-slot until the switch point is reached.

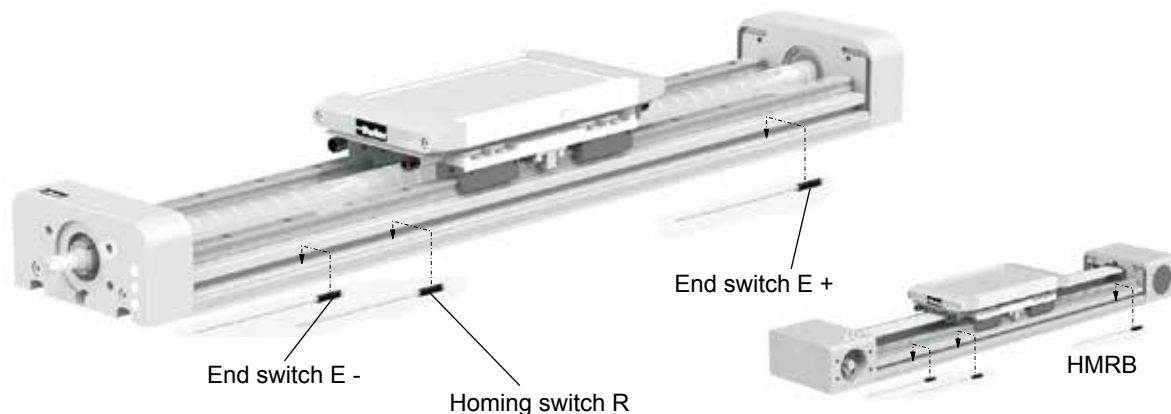

- ▶ Insert the magnetic switch into the T-slot, if not preassembled (or loosen it with a size 1.5 Allen key).
- ▶ Set up the switch point by moving the magnetic switch until the switch point is reached.
- ▶ Tightly clamp the magnetic switch with a size 1.5 Allen key.

Connecting the magnetic switches

	ATTENTION
	Risk of damage to cable!
	Cable shearing and scuffing will cause failures and damage.
	Route cable securely and tightly.

- ▶ Cut the magnetic switch cable to the desired length and strip it.
- ▶ Route the cable on the PCB according to the terminal assignment, see section 7.5.3 on page 22.
- ▶ Secure the loose cable in the T-slot with the cable holders.

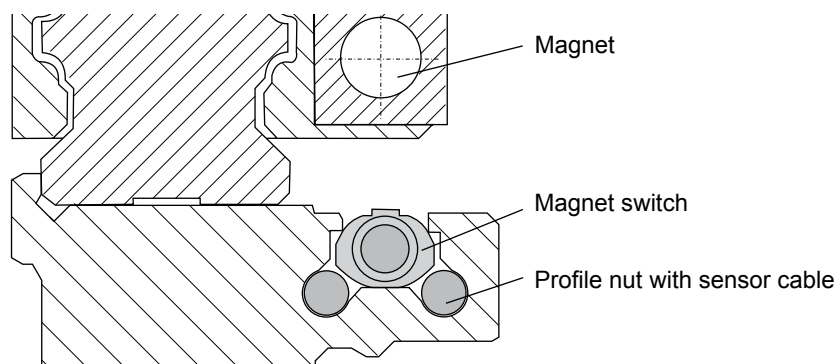

- ▶ Connect the respective connection cable with the M8 mounted connectors on the cover.
- ▶ Insert the connection cable in the controller (refer to section 11.2 on page 46 for information on ordering connection cables).

7.5.6 Setting up the External Magnetic Switches

Only possible with the IP54 cover!

Retrofitting:

All magnetic switches are mounted via a switch rail to be affixed onto the IP54 cover.

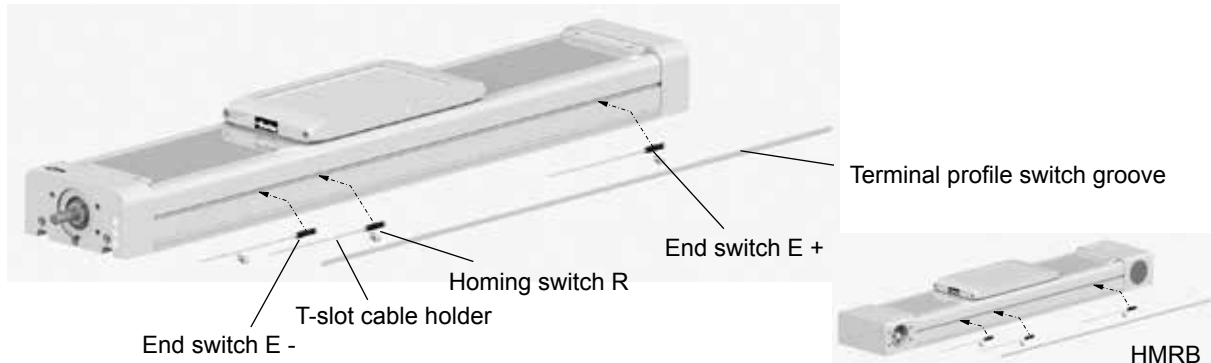

- ▶ Remove the **strip** from the IP54 cover.

Setting up the magnetic switches

- ▶ Insert the previously aligned magnetic switches into the switch rail (size 1.5 Allen key).

NOTE	
	Adjust the carriage to the desired position (end position / homing) and then move the magnetic switch in the T-slot until the switch point is reached.

Adjusting the switch points (setup)

- ▶ Move the magnetic switches until the switch point is reached.
- ▶ Tightly clamp the magnetic switch with a size 1.5 Allen key.

Connecting the magnetic switches

- ▶ Connect the respective connection cable with the M8 connector for the magnetic switch.
- ▶ Secure the loose cable in the T-slot with the cable holders.
- ▶ Insert the connection cable in the controller (refer to section 11.3 for information on ordering connection cables).

7.6 Impact Protection

Impact protection reduces the risk of mechanical damage from an unbraked, unforeseeable impact in the end position. If the safety distance of the end positions is crossed by the carriage and payload, the shock absorbers compensate, in full or in part, for the residual energy. The shock absorbers are only intended to protect a foreseeable impact of the carriage in the mechanical end position and not for continuous operation. The permissible energy absorption is listed in the HMR catalog. If there is an overload, the impact protection must be replaced.

The use of end position switches with the safety distance required for the application, as described in section 7.5.1, is not affected by this.

The IP54 cover must be opened as per section 7.4.1 on page 18 when retrofitting or replacing the impact protection.

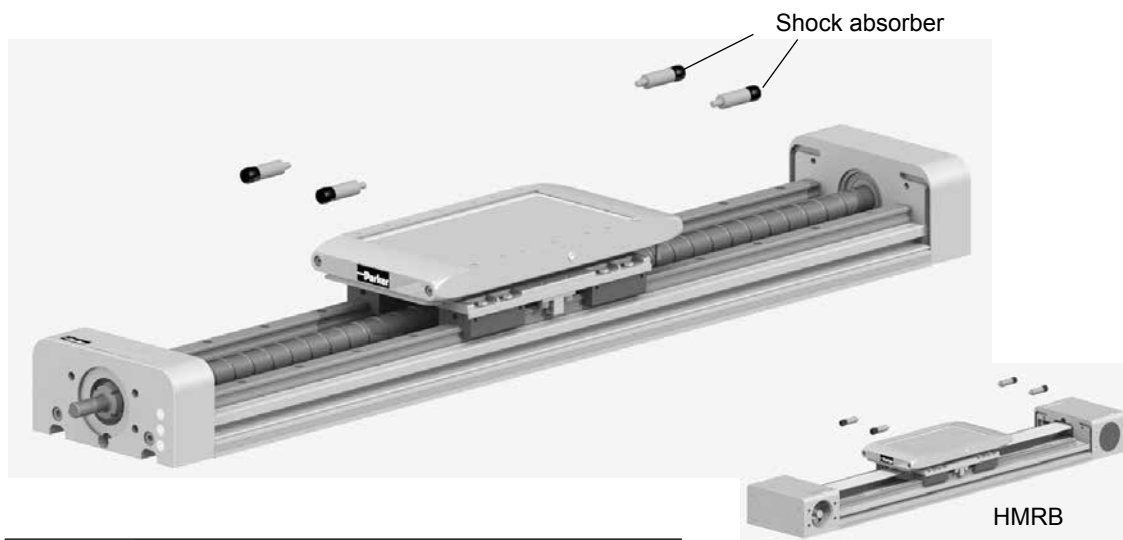

	NOTE
	► Adhere to the tightening torques for screws according to section 7.1. on page 12

7.7 Motor and Gearbox Mounting

Overview / exploded view of motor installation with a flange plate, using a toothed belt as an example.

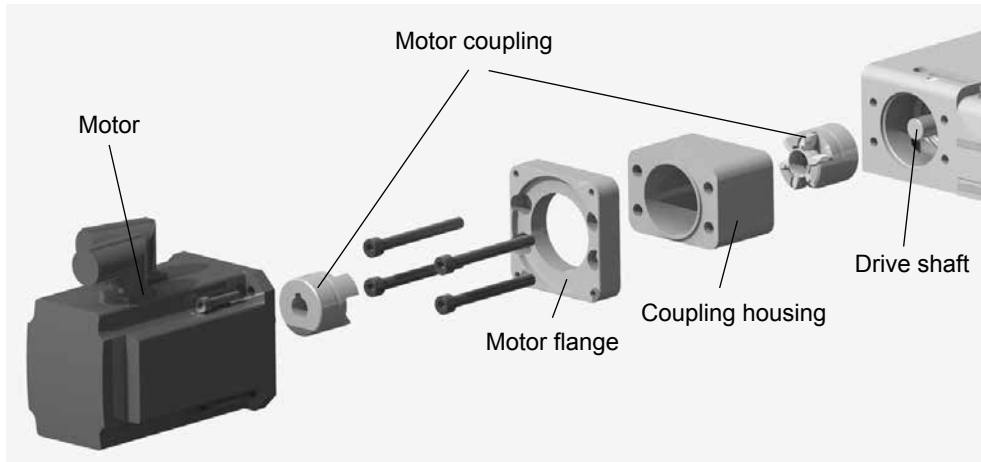

Overview / exploded view of gearbox installation with two flange plates, using a spindle drive as an example.

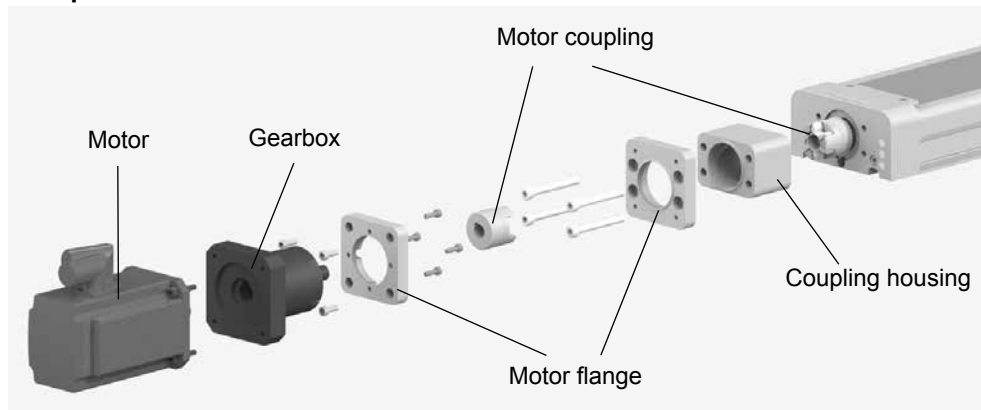

NOTE	
	<p>The motor flange usually consists of one flange plate. If the geometric requirements are unfavorable in the assembly, the motor flange can consist of two flange plates. The motor flange designation always remains the same and does not depend on whether a motor or a gearbox with motor is to be installed on the linear drive.</p>

7.7.1 Using the Correct Drive System

The drive system consists of a motor and/or gearbox and is connected to the linear drive in order to move the carriage linearly along with the mounted payload.

	WARNING
	<p>Hazard due to over-dimensioned drive system motor and gearbox.</p> <p>Severe injuries and damage to property that could even occur after longer periods of operation.</p> <p>► Corrected dimensioning of the drive system and matching to linear drive is necessary.</p>

To ensure that the linear drive is operated within the permissible load limits, the proper arrangement and selection of the motor system must be carried out by Parker-Hannifin or the operator.

EL-sizing, the software-based design program from Parker-Hannifin, also provides reliable combinations of linear drive and drive system. The maximum torque on the drive shaft of the linear drive must not be exceeded at any time.

7.7.2 Coupling Housing, Motor Coupling and Flange

	WARNING
	<p>Shaft breakage due to NON-alignment</p> <p>Severe injuries and damage to property caused by unbraked payload.</p> <p>► Centering of drive shaft and motor shaft/gearbox shaft via coupling housing and flange.</p>

The drive system, which consists of the motor and/or gearbox, must be properly connected to the drive shaft of the linear drive. To ensure the shafts are aligned with one another, a tailored combination of a coupling housing, motor coupling and motor flange (for externally supplied motors/gearboxes as well) must be fitted.

Therefore, it is best if you only use suitable products offered by the manufacturer.

Connection dimensions screw drive - HMRS

Product Profil	Ø A	B	Ø D ^{H7}	E	Ø F ^{H7}	G	HB Basis	HR verstärkt
HMRS08	42	M4	34	3.0	6	11	26	37.0
HMRS11	51	M6	39	5.0	10	18	32	52.0
HMRS15	72	M8	54	4.0	12	31	36	60.0
HMRS18	80	M8	64	2.5	15	33	44	67.5
HMRS24	95	M10	80	2.5	20	37	55	83.0

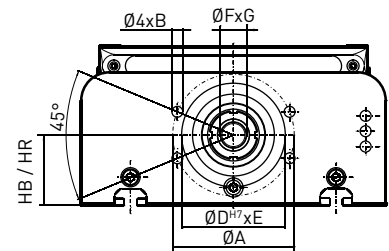

Connection dimensions belt - HMRB

Product Profil	Ø A	B	Ø D ^{H7}	E	Ø F ^{H7}	G	GV	HW
HMRB08	42	M4	34	2.5	10	13.5	2.5	25
HMRB11	51	M6	39	1.2	12	20.0	0.0	31
HMRB15	72	M8	54	2.1	15	19.3	7.0	45
HMRB18	80	M8	64	4.0	18	21.8	1.5	50
HMRB24	95	M10	80	2.5	24	24.0	4.0	60

Basic

reinforced

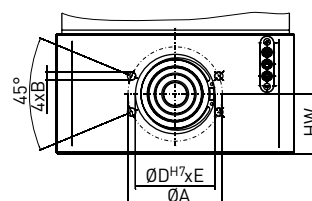
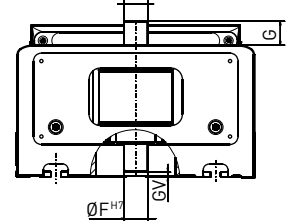
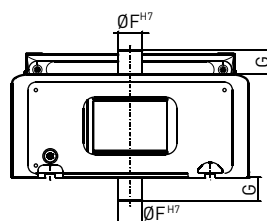

Modular Electric HMR Linear Drives

7.7.3 Drive System Installation

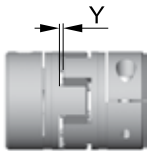
		NOTE
		<p>When installed, both parts of the motor coupling must have a defined gap dimension "Y". Also note the clearance dimensions in the following table in relation to the shaft of the motor or gearbox used.</p>

Motor dimensions [mm]

	D _{min}	E _{max}	F	G _{min}	G _{max}	P	X	X ₀₉₀₋₂₇₀	Y	Z
HMRS08 HMRB08	30	5	6-14	15	20	15	12	-3	1	8
		10		20	25	20				13
		15		25	30	25				18
HMRS11 HMRB11	35	5	6-16	15	20	15	20	-2	1,5	8
		10		20	25	20				13
		15		25	30	25				18
HMRS15 HMRB15	50	5	8-24	20	30	20	28	4	2,0	5
		15		31	40	30				15
		25		41	50	40				25
HMRS18 HMRB18	60	5	10-28	30	40	20	32	4	2,0	10
		15		41	50	30				20
		25		51	60	40				30
HMRS24 HMRB24	77	4	14-38	40	50	20	35	10	2,5	15
		14		51	60	30				25
		24		61	70	40				35

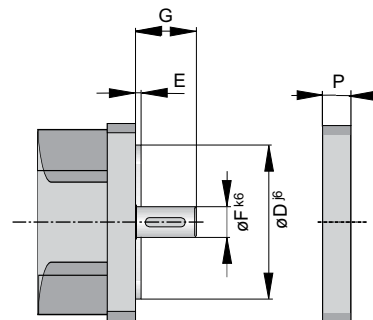

	NOTE
	<p>► Adhere to the tightening torques for screws according to section 7.1 on page 12.</p>

- Mount the **motor coupling** on the drive shaft with clearance "X" (see table above, depending on type).

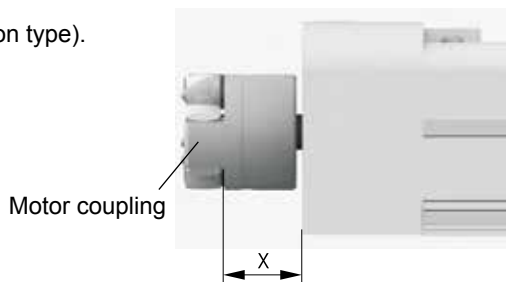

- Insert the **coupling housing** centered into the end cap.

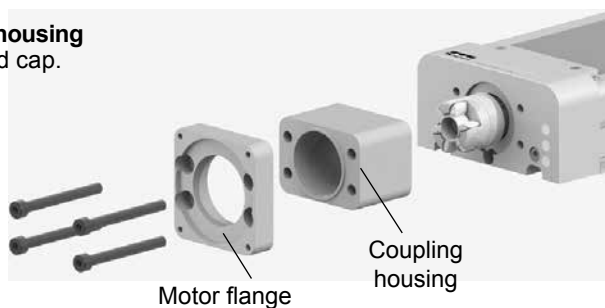

- Center the **motor flange** on the **coupling housing** and tighten the screws.

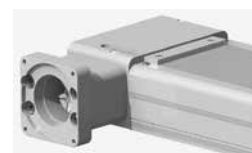

- ▶ Mount the motor coupling with clearance “Z” to the motor shaft or gearbox shaft (see table page 27).

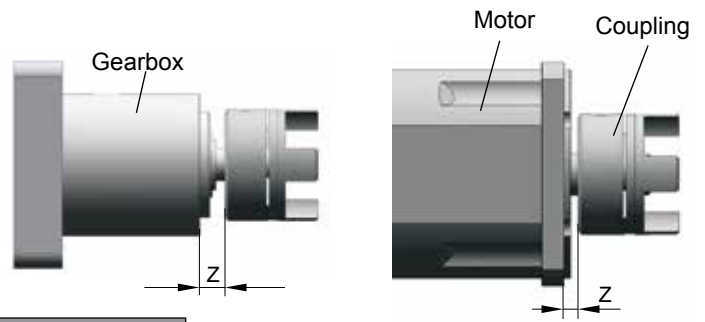

	WARNING
	<p>Shaft breakage due to NON-alignment</p> <p>Severe injuries and damage to property caused by unbraked payload.</p> <ul style="list-style-type: none"> ▶ Centering of drive shaft and motor shaft/gearbox shaft via coupling housing and flange.

Assembly motor flange with one flange plate

- ▶ Insert both parts of the motor coupling together in the coupling housing.

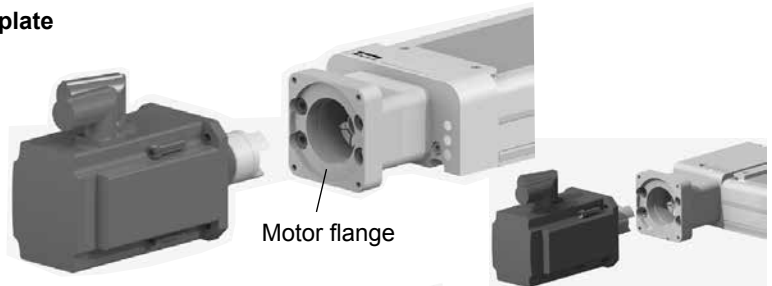

- ▶ Center the motor and secure with screws.



Assembly motor flange with two flange plates

- ▶ Center and secure the second flange plate on the motor/gearbox side.

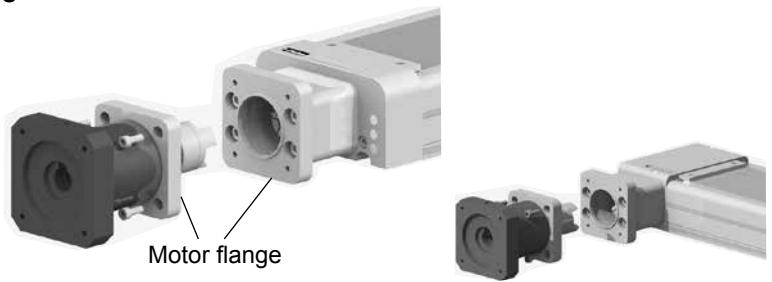

- ▶ Insert both parts of the motor coupling together in the coupling housing.
- ▶ Center and secure the flange plates to one another.

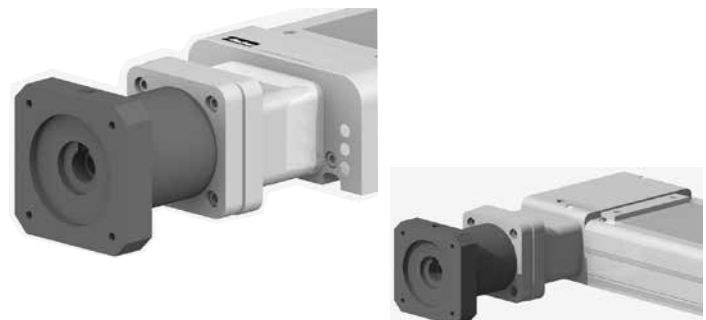



- ▶ Completion: Installation of motor on gearbox.

8 Commissioning

The HMR linear drive can generate quick linear movements with great force. This can result in injuries due to crushing of body parts or damage caused by collision with other system parts if the safety regulations are not observed.



An EMERGENCY STOP device must be available. The run-out path (distance after an EMERGENCY STOP) must be secured.

8.1 First Commissioning

	WARNING
	Crushing hazard when moving Crushing hazard caused by incorrect direction of travel
	This could result in severe injuries and damage to property.
	<ul style="list-style-type: none"> ▶ Keep hands out of the operating area of the linear drive. ▶ Conduct a start-up check in the collision-free stroke area with slow, short movements. ▶ Check the direction of movement of the motor and carriage with a brief start-up.

Before the first and each additional commissioning, check the following:

- ▶ Are the connection conditions correct?
- ▶ Can anyone enter the area of action?
- ▶ Are there any obstacles or tools in the movement area of the load?

	ATTENTION
	Overload hazard due to excessive load, excessive mass or excessive speed.
	Immediate damage to components or fatigue failure can occur.
	<ul style="list-style-type: none"> ▶ Review and adhere to the catalog specifications on configuration of the HMR. ▶ The linear drive must first run through the entire movement area at slow speed to determine any potential collision areas. Any items blocking the drive area must be removed immediately!

8.2 Operation

After HMR installation, the entire system may only be operated under operating conditions in compliance with the valid machinery directive.

A risk analysis with the CE conformity granted as a result is a prerequisite for safe operation according to proper use.

Installation of the EMERGENCY STOP device must be checked for proper function.

Observe the operating instructions for the entire system.



9 Maintenance and Repair

9.1 Customer Service

To obtain the address for spare parts and customer service, see the back of these operating instructions.

9.2 General Cleaning

Maintenance and repair work may only be carried out by trained personnel

	CAUTION
	<p>Crushing hazard due to unexpected movements</p> <p>This could result in severe injuries or damage to property.</p> <p>► Bring system to a standstill and secure.</p>

Only use lint-free cloths and mild substances that will not harm the material for cleaning.

Potential designs:

IP20 (without cover)

The linear drive must always be kept free of contamination in the area of the guides and the drive unit. Clean regularly according to the environmental conditions.

IP54 (with cover)

Routine cleaning on the outside, particularly the surface between the Outer band and the support on the aluminum profile.

The sealing lips on the yellow covers of the carriage and on the lateral wipers can become clogged. Clean as required.

9.3 Lubrication Intervals

The HMR drive unit is lubricated when delivered. The lubrication channels within the carriage that run to the runner blocks (and the ball screw nut for the ball screw drive) are filled and sealed off.

The amount of relubrication required depends on the operating mode, the requirements and, lastly, the type of guide.

We recommend a check of the linear drive **after a service time of**

HMR08:	120 km
HMR11:	1000 km
HMR15, -18, -24:	max. 2000 km or an operating period of 12 months, depending on the application..

Here you must also take into account:

- Load
- Speed
- Temperature
- Ambient conditions.

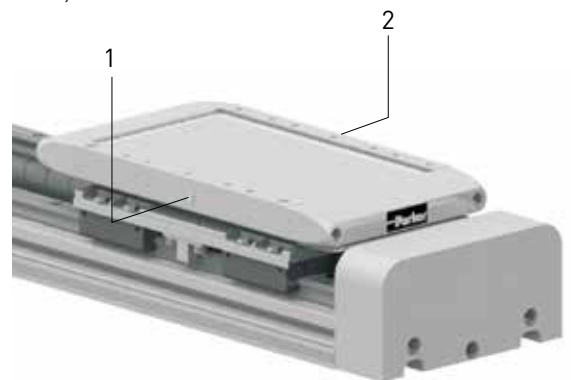

Use of grease:

	NOTE
	► For lubrication we recommend grease from Klüber named ISOFLEX TOPAS NCA 52 or a comparable product.

- Lubricate the runner blocks (and the ball screw nuts for linear drives with screw) via the lateral lubricating nipples on the carriage.

Visual inspection for lubrication:

- For the design with **IP54 cover**: Ensure that the Outer band has a thin layer of lubrication on both sides.
- Ensure that the guide rail and, if necessary, the ball screw drive are covered with a clean, thin layer of lubrication.

9.4 Checking the Play of the Guide System

Horizontal and vertical play can occur after a certain number of operating hours and service time. Checks for play should only be evaluated and conducted by trained mechanical technicians.

	NOTE
	With the ball bearing guide, no play must be discernible when the carriage is rotated by hand.

9.5 Checking the Bearing Play

If increased noise development occurs when operating the HMR, check the bearings for wear. The shaft bearings have lifelong lubrication.

A check should be done every 2000 km or every 12 months.

9.6 Checking the Play in the Ball Screw Drive and Nut

A check should be done every 2000 km or every 12 months.

- ▶ Loosen and remove the motor / gearbox / drive unit.

Check the ease of movement of the screw with nut.

- ▶ Move the carriage by hand by rotating the drive shaft over the entire stroke in both directions of rotation.

	NOTE
	Movement should be without jerks, smooth and without any noticeable running noises within the permissible no load torque (refer to catalog).

Check the axial play between the screw and the nut

- ▶ Fix the ball screw drive in position radially and axially by blocking.
- ▶ Move the carriage by hand axially in both directions.

	NOTE
	When the drive shaft or screw is blocked, it should not be possible to move the carriage by hand.

9.7 Check and adjust belt tensioning

Retensioning of the belt within performance is not necessary. With a nominal loading by 75% of the permitted thrust force a replacement of the belt after 10,000 km is advised.

A check of the right belt tensioning should be done every **2,000 km** or **every 12 months**.

Measurement can be carried out using different methods:

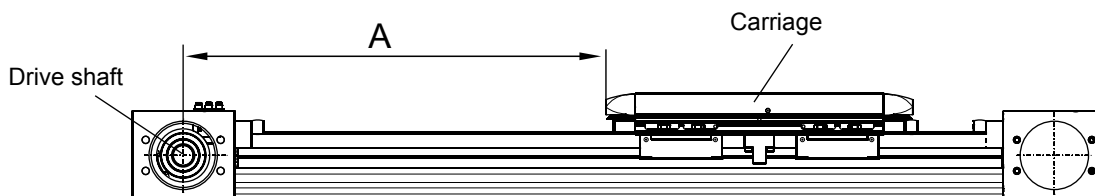

Measurement A for adjusting the belt tension

9.7.1 Check belt tensioning

The most certain results measuring belt tensioning can be adjusted and reviewed in practice by an experienced specialist. However, the toothed belt tension is measured and adjusted most reliably by using a belt tension measuring device. One method is to adjust using the **frequency meter**.

	ATTENTION
	The max. permissible pulling force of the toothed belt may not be exceeded under any circumstances.

Please direct any queries related to purchasing or loan of a rate monitor to the manufacturer directly.

- ▶ If present the IP54 cover must be removed described in section. 7.4.1.
- ▶ The payload must be removed from vertical oriented positioners.
- ▶ Move the carriage unloaded in both directions so the belt will subside.
- ▶ Adjust **distance A** (see page 32) from the centre of the **drive shaft** to the **carriage** with 500 mm or 250 mm on short positioners.

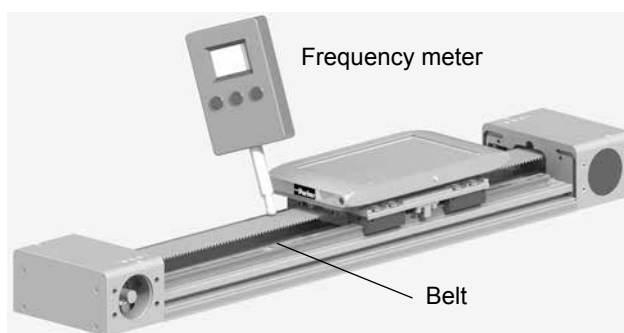

- ▶ Activate the **toothed belt** by pulling the center of the clear toothed belt until it vibrates.
- ▶ Measure the resulting frequency in the center of the clear toothed belt length with the **frequency meter**. Take the measurement three times.
- ▶ Check the measured frequency with values from following table.

Belt frequency f

Product size, Motor mounting position	Belt	Clear belt length 500 mm	Clear belt length 250 mm
		Frequency	Frequency
HMR08	20 AT 3	85 Hz	170 Hz
HMR11	25 RPP 5	83 Hz	166 Hz
HMR15 / 090°/270°	40 RPP 5	85 Hz	170 Hz
HMR15 / 0°/180°	25 RPP 5	83 Hz	166 Hz
HMR18 / 090°/270°	50 RPP 5	86 Hz	172 Hz
HMR18 / 0°/180°	40 RPP 5	83 Hz	166 Hz
HMR24 / 90°/270°	75 RPP 8	88 Hz	176 Hz
HMR24 / 0°/180°	50 RPP 8	108 Hz	216 Hz

- ▶ Follow the instructions depending of the measured variance:

$f < 70\%$	Replacement of the belt.
$70\% < f < 90\%$	Retention the belt.
$90\% < f < 110\%$	No action necessary.

	Note
	After retensioning the belt twice a replacement is necessary.

Modular Electric HMR Linear Drives

9.7.2 Testing the toothed belt tension with a force/displacement measuring device

Please direct any queries on the force/displacement measuring device to Parker, ID no. 037-000202. Measurement process:

- ▶ For vertical alignment of the drive, first dismantle the payload.
- ▶ The IP54 cover must be opened so that the toothed belt is accessible, in accordance with section 7.4.1.
- ▶ Move the carriage without loads in both directions, so that the toothed belt can settle.
- ▶ Adjust **Measurement A** (see page 32) from the middle **drive shaft** to the **carriage** with 500 mm or 250 mm for short drives
- ▶ For a correct belt tension the belt must be able to be pushed through 6 to 7 mm for an uncovered belt length of 500 mm or 3 to 3.5 mm for 250 mm.

With a force/displacement measuring device (Dynamometer FDN200 with test pins, ID No. 16187FIL) the following force should be read:

Toothed belt force

Product size, Motor units	Belt	Clear belt length 500 mm	Clear belt length 250 mm
		Force for 7 mm	Force for 3.5 mm
HMR08	20 AT 3	20 ± 1 N	20 ± 1 N
HMR11	25 RPP 5	43 ± 1 N	43 ± 1 N
HMR15 / 090°/270°	40 RPP 5	62 ± 1 N	62 ± 1 N
HMR15 / 0°/180°	25 RPP 5	43 ± 1 N	43 ± 1 N
HMR18 / 090°/270°	50 RPP 5	71 ± 1 N	71 ± 1 N
HMR18 / 0°/180°	40 RPP 5	60 ± 1 N	60 ± 1 N
HMR24 / 90°/270°	75 RPP 8	161 ± 2 N	161 ± 2 N
HMR24 / 0°/180°	50 RPP 8	196 ± 2 N	196 ± 2 N

If the value measured is lower than the value stated in the table above, the toothed belt must be replaced.

9.7.3 Tensioning of the belt

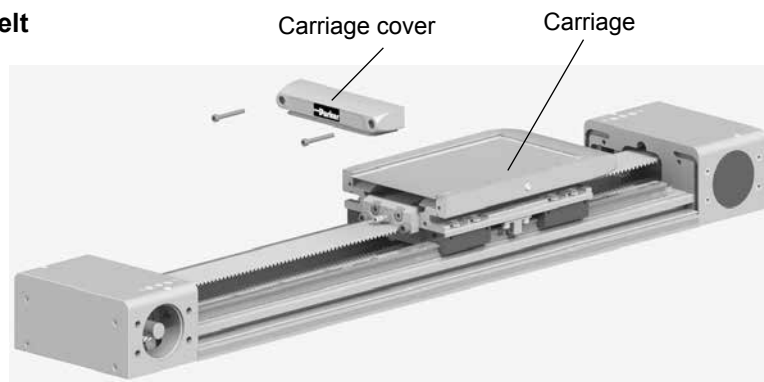

- ▶ Remove the **carriage cover** in order to reach the parts underneath

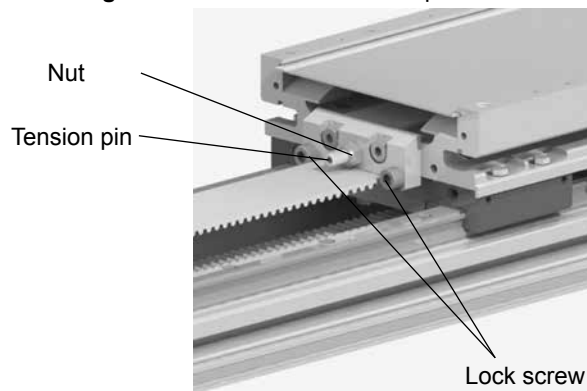

- ▶ Loosen the **nut** from **spiral tension pin** and **lock screw**.
- ▶ Check the belt tensioning while screwing the **Tension pin** as per section 9.7.1 on page 33.
- ▶ If the belt tensioning is adjusted the **nut** of the **Tension pin** can be tightened and the **lock screws** equally fixed by 10% of the shown value.

9.8 Checking the Cover Function

With the IP54 cover, the proper wiper function only occurs when a slight tread can be detected on the Outer band. Scores or streaks of residue indicate defective or dirty wipers around the carriage. Replacement is required.

9.9 Replacing the Carriage

9.9.1 Disassembly of Carriage Ball Screw Drive

If present, the IP54 cover must be removed (refer to section 7.5.1 on page 17).

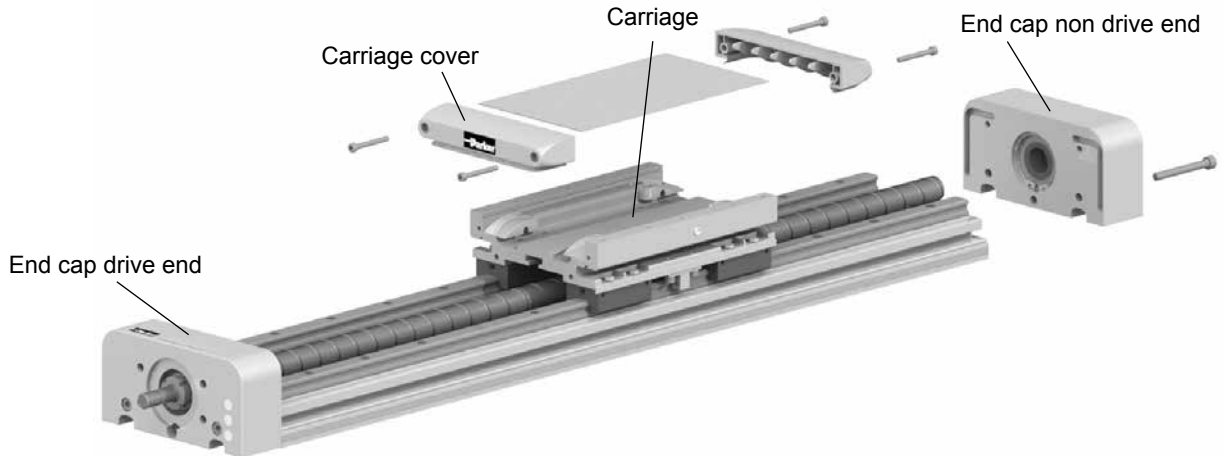

- ▶ Loosen the **carriage cover** in the direction of the **end cap drive end** side in order to reach the screws underneath.
- ▶ Place something such as wood underneath the screw.
- ▶ Loosen the screws from the **end cap non drive end** side and remove the cover.

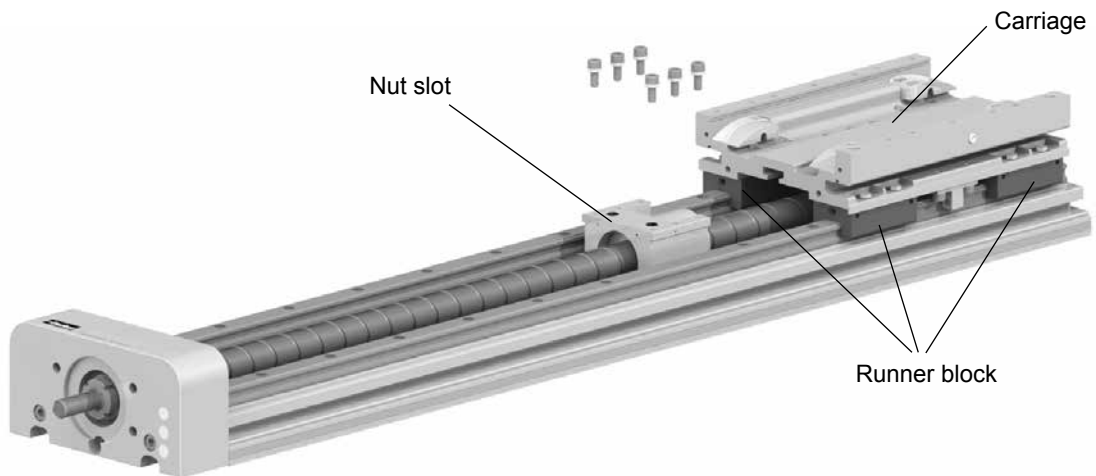

- ▶ Remove the six screws of the nut slot.

	ATTENTION
Risk of damage to runner blocks	
Tilting will damage the recirculating ball runner block!	
▶ Carefully move carriage onto the guide rails with a parallel movement.	

- ▶ Carefully move the carriage from the guide, without tilting, and insert the transport safety device such that no balls fall out of the runner block.

Modular Electric HMR Linear Drives

9.9.2 Installing the carriage ball screw drive

	ATTENTION
Risk of damage to runner blocks	
Tilting will damage the recirculating ball runner block!	
▶ Carefully move carriage onto the guide rails with a parallel movement.	

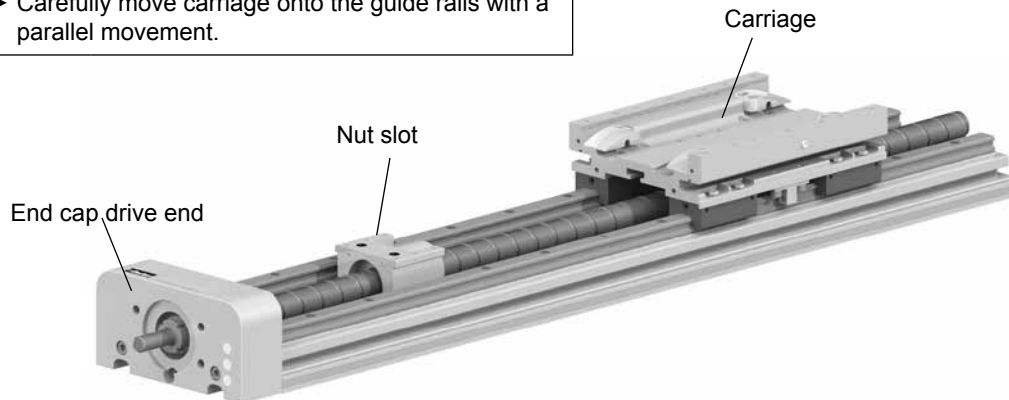

- ▶ Very carefully place the **carriage** onto the guide rails without tilting. When placing the **carriage** onto the guide rails, remove the transport safety device.

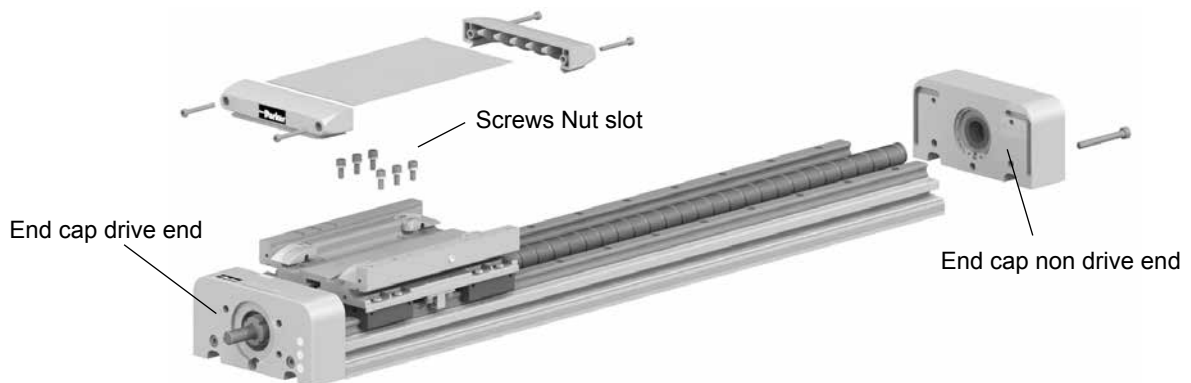

	NOTE
▶ Adhere to the tightening torques for screws according to section 7.1. on page 12.	

- ▶ Push the carriage over the **nut slot** so that the screws can be fitted. Only insert the screws loosely.
- ▶ Push the **end cap non drive end** onto the floating bearing and insert the screws loosely.
- ▶ Align the **nut slots** axially parallel on the inside of the carriage (the stop side).
- ▶ Screw the screws in tightly in the **nut slot**.

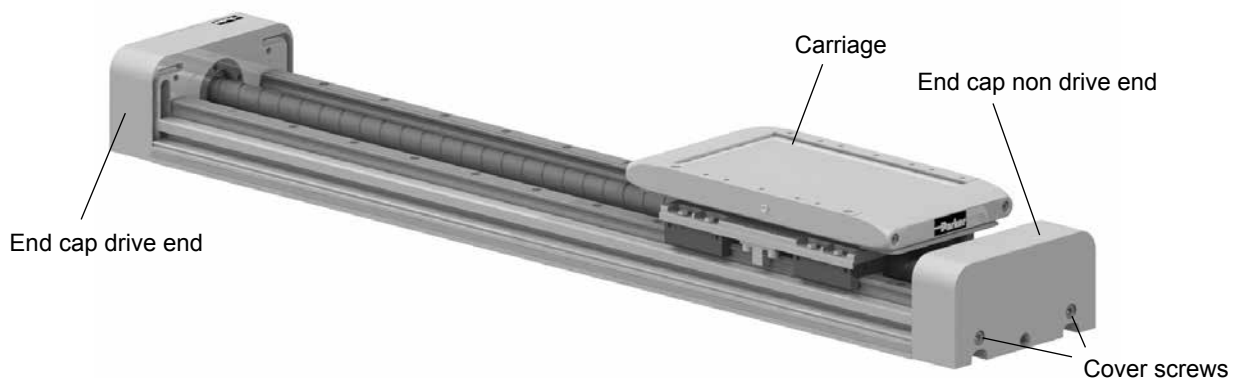

- ▶ Move the **carriage** to **end cap drive end** (the end cap drive end will align itself).
- ▶ Align the **end cap non drive end** horizontally and gradually screw the **cover screws** down tightly and in steps.

9.9.3 Disassembly of carriage belt drive

If present, the IP54 cover must be removed as per section 7.5.1 on page 18.

The belt tensioning block needs to be removed on both sides. Following the procedure is described for one side.

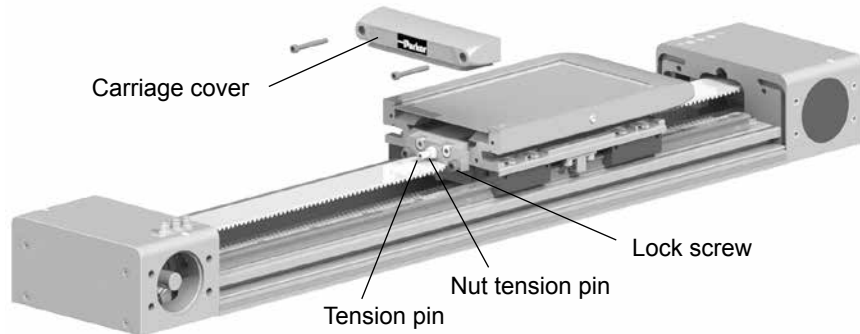

- ▶ Loosen the **carriage cover** in order to reach the parts underneath.
- ▶ Remove the **lock screw**.
- ▶ Loosen the nut of the **tension pin** a bit and release the pin.

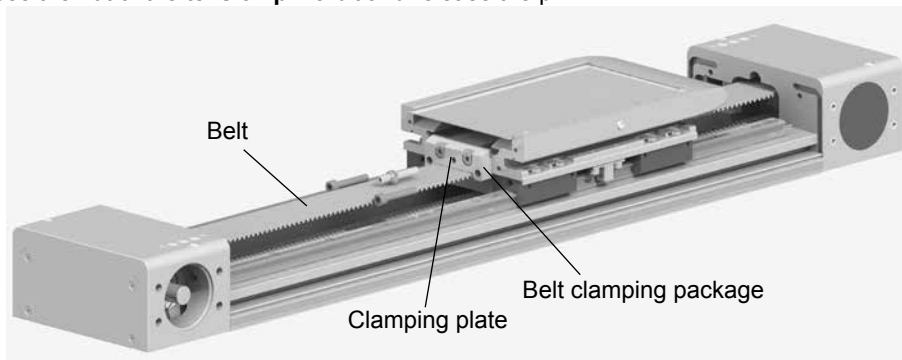

- ▶ Loosen the screw of the **clamping plate** and remove it.
- ▶ Pull out the **belt clamping package**.
- ▶ Repeat this with the other belt tensioning package.
- ▶ This time remove the **belt** of the **belt clamping package**.

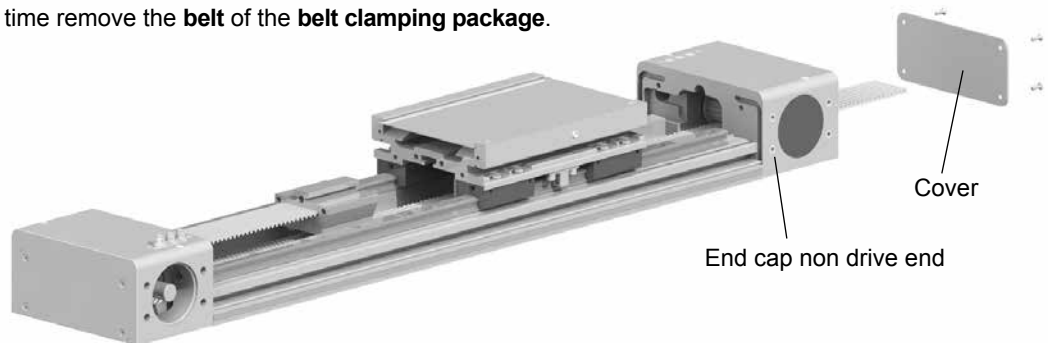

- ▶ Remove **cover** from the **end cap non drive end** side.
- ▶ Lay out the **belt**.

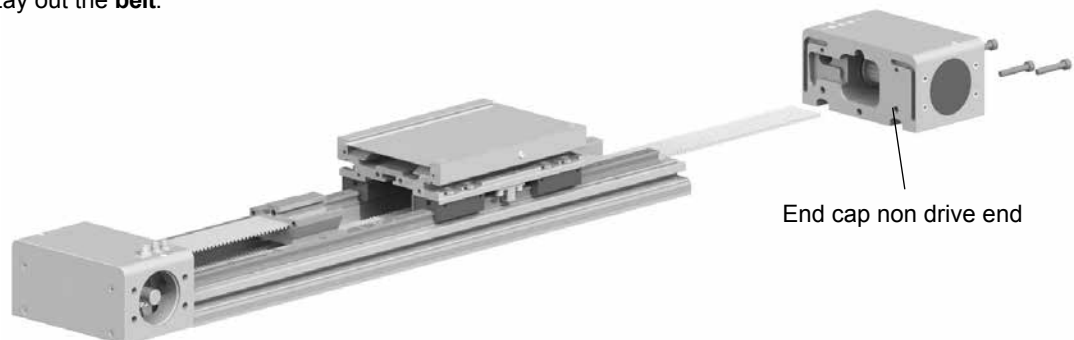

- ▶ Loosen the screws from **end cap non drive** end side and remove it.

Modular Electric HMR Linear Drives

	ATTENTION
Risk of damage to runner blocks!	
Tilting will damage the recirculating ball runner block.	
▶ Carefully move carriage onto the guide rails with a parallel movement.	



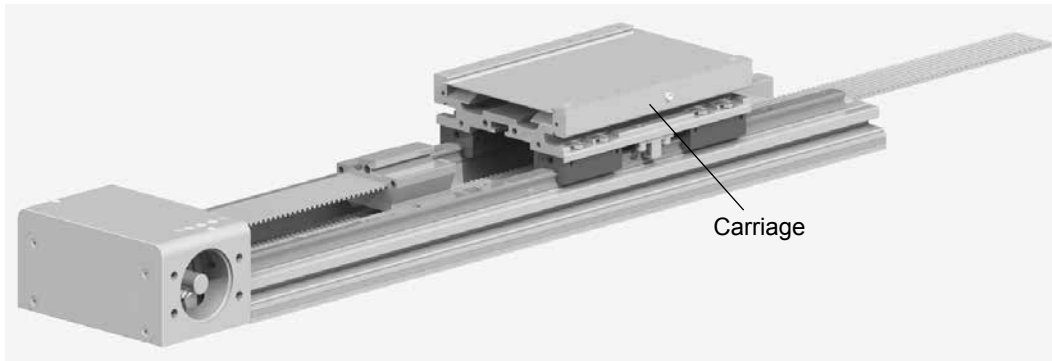

- ▶ Carefully move the **carriage** from the guide, without tilting and insert the transport safety device such that no balls fall out of the **runner block**.

9.9.4 Installing the carriage belt drive

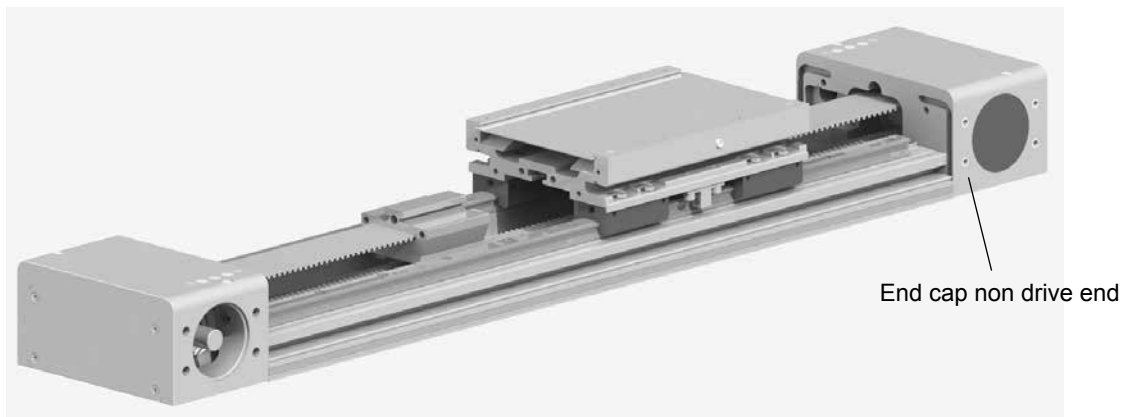

- ▶ Very carefully place the **carriage** onto the guide rails without tilting.
- ▶ When placing the **carriage** onto the guide rails, remove the transport safety device.



	NOTE
▶ Adhere to the tightening torques for screws according to section 7.1 on page 12.	

- ▶ Place the **cover circulation** horizontally and in the centre and screw it in tightly.
- ▶ Carry back the belt on the upper side of the non drive end pulley.
- ▶ Fasten the cover to the end cap non drive end.

Subsequential steps can be done in opposite sequence then disassembly.

Finally tension the belt as per section 9.7.2 on page 34.

9.10 Replacing the Carriage

9.10.1 Disassembly of Carriage Ball Screw Drive

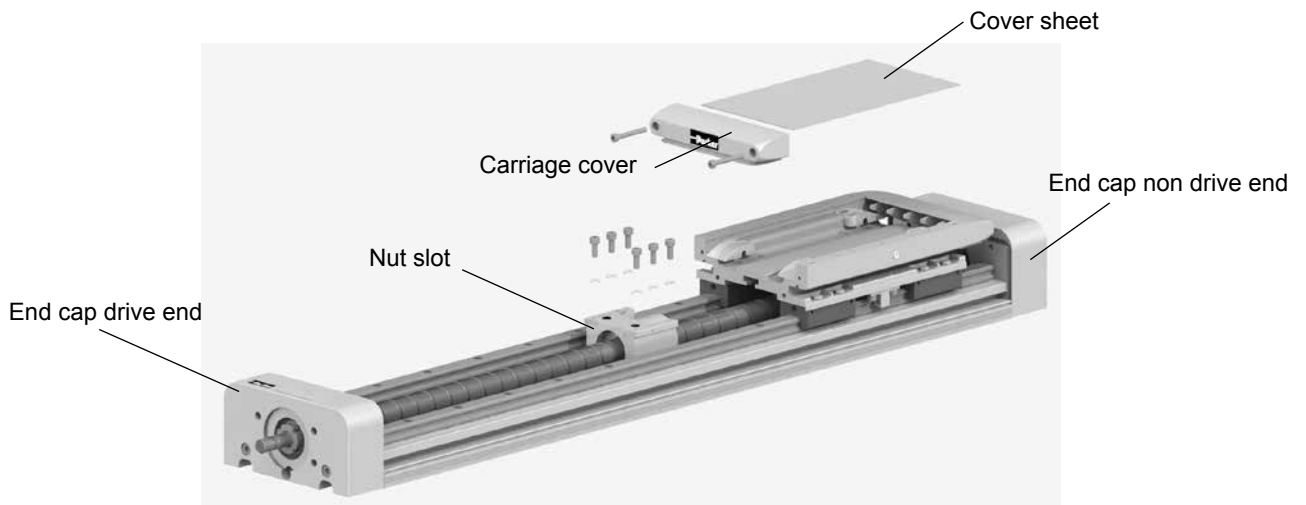

- ▶ Loosen the **carriage cover** and the **cover sheet** in order to reach the screws underneath.
- ▶ Loosen the screws on the **nut slot**.
- ▶ Loosen the screws on the **end cap drive end**.
- ▶ Loosen the screws on the **end cap non drive end**.

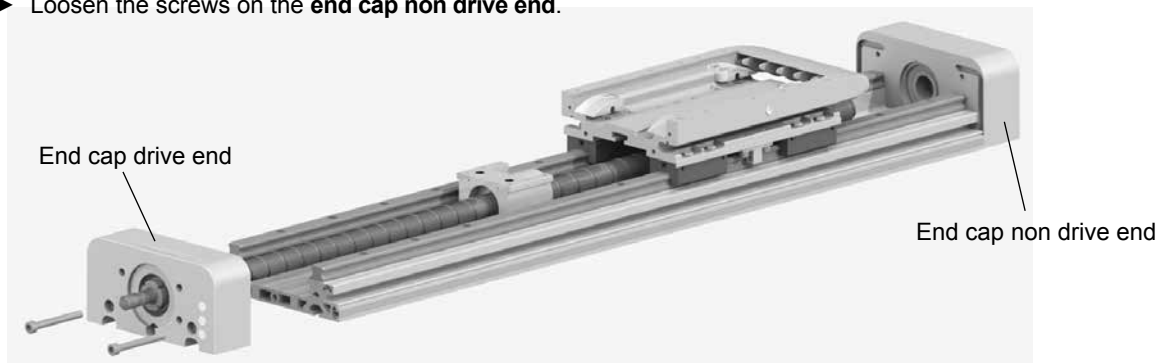

- ▶ Pull the **cover drive** out with the complete drive body.

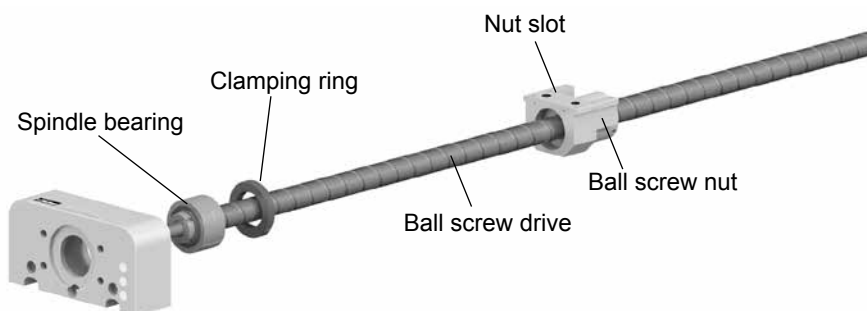

- ▶ Remove the **terminal ring** for securing the **spindle bearing** and pull off the cover drive from the spindle bearing.
- ▶ Remove the circlip of the floating bearing in the **cover circulation** and remove the bearing from the cover.

9.10.2 Installing the Drive Type Ball Screw

	NOTE
<p>▶ Adhere to the tightening torques for screws according to section 7.1 on page 12.</p>	

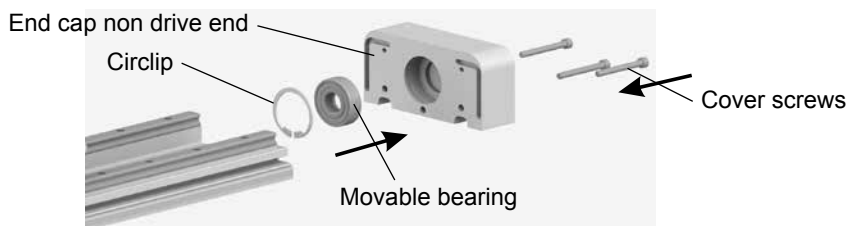

- ▶ Insert the **movable bearing** into the **end cap non drive end** and secure it with the **circlip**.
- ▶ Assemble the **cover circulation** with the **cover screws** on the profile. Only screw the screws in enough for the cover to remain movable radially.

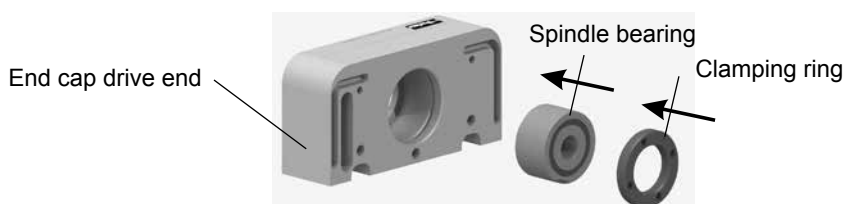

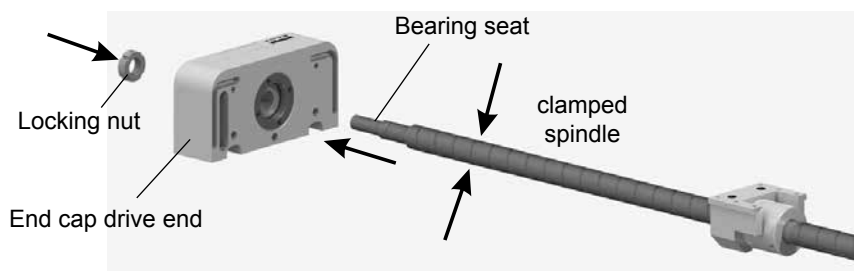

- ▶ Press the **spindle bearing** into the **cover drive** and secure it with the **terminal ring**.
- ▶ **The terminal ring must be secured against coming loose with Loctite 243.**



- ▶ Clamp the **spindle** close to the **drive pin** in the vice. (Suitable protective jaws must be used when clamping in order to avoid damaging the threaded spindle.)
- ▶ Press the **cover drive** with the **spindle bearing** onto the **bearing seat**. With this the force must be only transferred with a suitable sleeve over the inner ring in order to avoid damaging the bearing.
- ▶ Secure the **spindle bearing** with the **locking nut** and the prescribed tightening torque (see table below). With this the spindle bearing is pre-stressed axially. Secure the spindle bearing by tightening the terminal screw in the nut.

Tightening torques for spindle nuts:	
HMRS08	4 Nm
HMRS11	8 Nm
HMRS15	10 Nm
HMRS18	18 Nm
HMRS24	25 Nm

	ATTENTION
	It is not possible to lubricate the ball screw nut!
	O-rings for sealing off the lubrication channel are missing or seated incorrectly.
	▶ Check that the O-ring is seated correctly while pushing underneath the carriage.

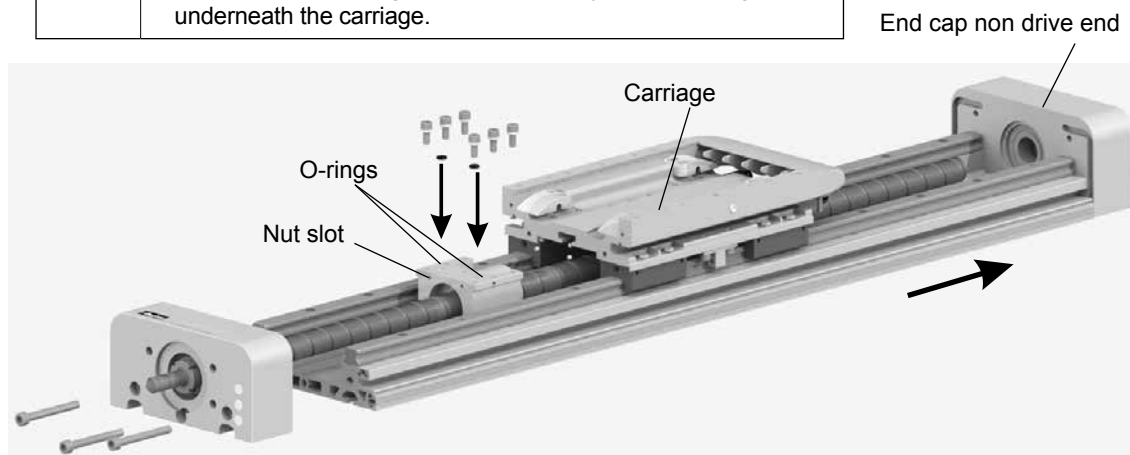

- ▶ Push the drive body with the **nut slot** under the **carriage** in such a way that the threaded holes are showing upwards towards the carriage. Before sliding in, twice insert the **O-rings** for sealing the lubricating joint in the counterbores of the nut slot.

For the following ensure that there is an exact axial alignment of the spindle:

- ▶ Screw 6 screws into the **nut slot** under the **carriage**. The screws are secured against coming loose with Nord-Lock washers.
- ▶ Insert the free end of the spindle into the floating bearing in the **cover circulation**.
- ▶ Screw the cover drive onto the base profile. Only screw the screws in enough for the cover to remain movable radially.

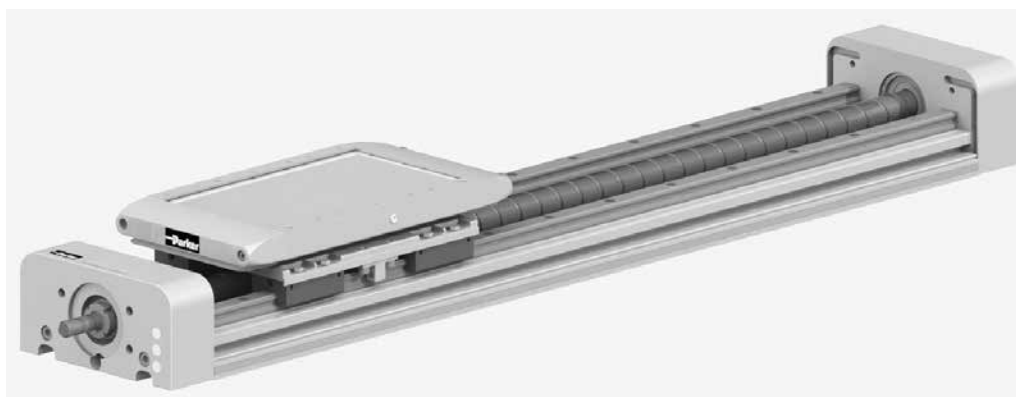

- ▶ Push the carriage until it is just in front of the cover drive side. With this the cover aligns radially to the spindle nut.
- ▶ Align the cover drive side horizontally and gradually screw the cover screws down tightly.

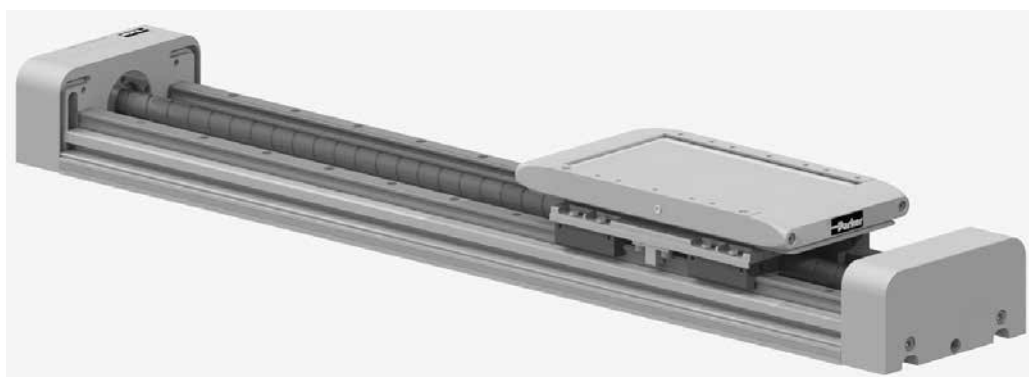

- ▶ Push the carriage until it is just in front of the cover circulation side. With this the cover aligns radially to the spindle nut.
- ▶ Align the cover circulation side horizontally and gradually screw the cover screws down tightly.

9.10.3 Disassembly of Drive Type Belt

If present, the IP54 cover must be removed as per section 7.4.1 on page 18.

The belt tensioning block needs to be removed on both sides. Following the procedure is described for one side.

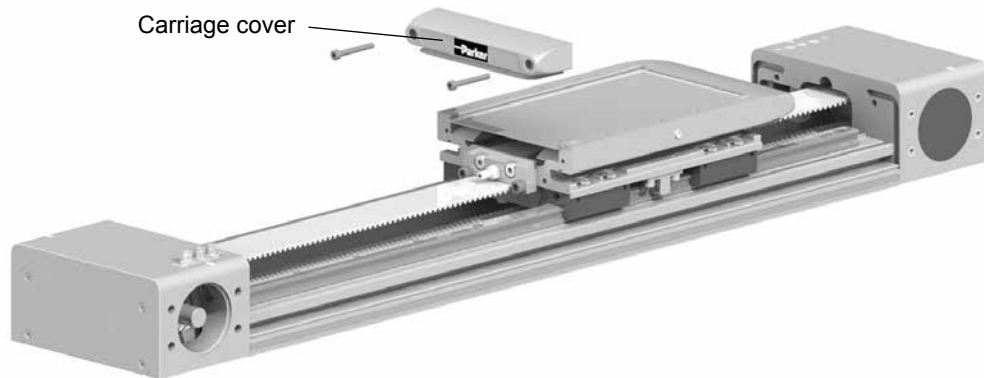

- ▶ Loosen the **carriage cover** in order to reach the parts underneath.

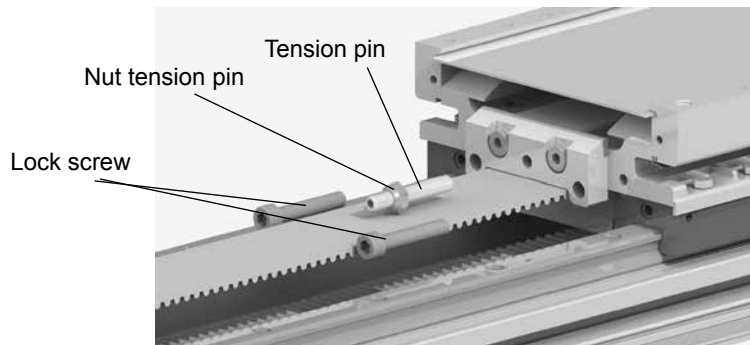

- ▶ Remove the **lock screw**.
- ▶ Loosen the **nut** of the **tension pin** a bit and release the **pin**.

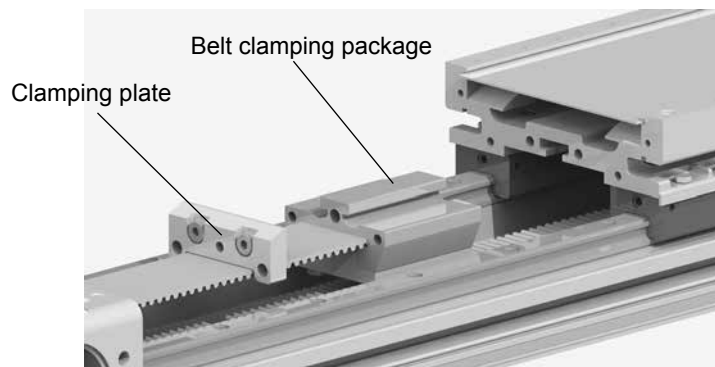

- ▶ Loosen the screw of the **clamping plate** and remove it.
- ▶ Pull out the **belt clamping package**.

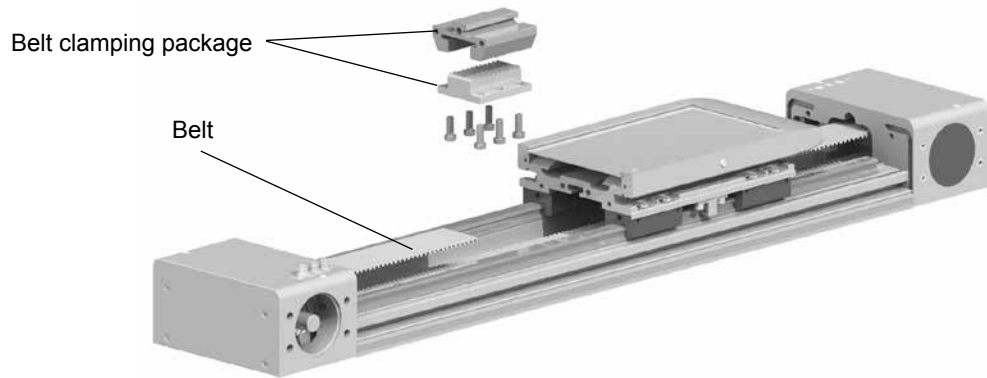

- ▶ Remove the screws of the **belt clamping package** and lay out the belt.
- ▶ Repeat this with the other belt tensioning block.

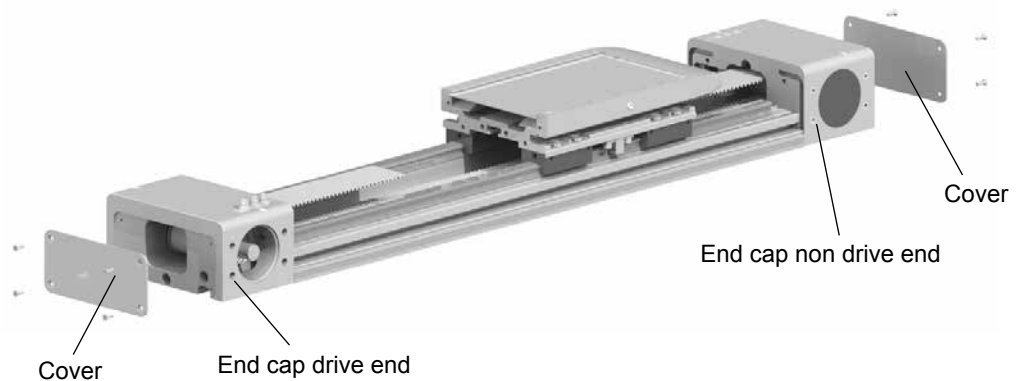

- ▶ Remove **cover** from the **end cap drive end** and **end cap non drive end side**.

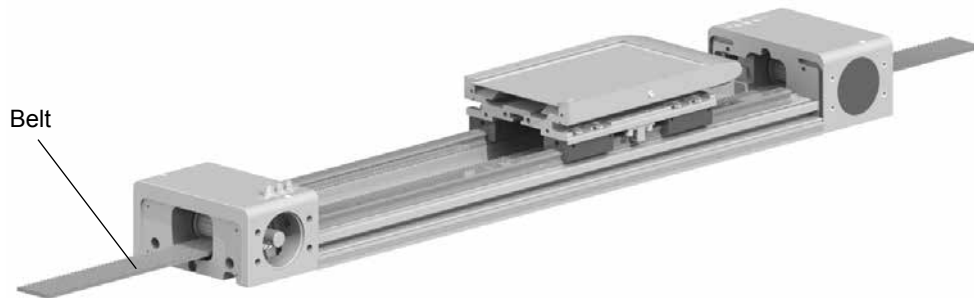

- ▶ Lay out the **belt** and take it out.

9.10.4 Installing Drive Type belt



Installation can be done in opposite sequence than disassembly.
Tension the belt as per section 9.7.2 on page 34.

	NOTE
	▶ Adhere to the tightening torques for screws according to section 7.1 on page 12.

10 Decommissioning

10.1 Disassembly of a Machine or System

Disassembly and the final shutdown of the HMR must be carried out by trained mechanical or electrical specialists.
No stored energy (springs, fluid, pressure).

	CAUTION
	Crushing hazard due to unexpected movements
	This could result in severe injuries or damage to property.
	▶ Bring system to a standstill and secure.

- ▶ Pay attention to the weight of any loads being lifted during vertical installation.
- ▶ Screws and toothed belts are not self-locking, which means that the Drive Type, carriage and load could crash down.

10.2 Disposal

The HMR does not contain any hazardous substances that require special attention during disposal. Lubricant residue is possible and should be expected.

In addition to the main aluminum component, there are also installed steel parts and plastics such as PU and NBR. Non-ferrous metal is present in small quantities only.

Electrical components (if used during operation) such as the motor and electronic switches must be disposed of according to the local regulations in force.

11 Retrofit Kits

11.1 IP54 Cover

If the cover is to be completely retrofitted, the product key must be indicated.

Example: HMRS15C100-1200-000000000

Example: HMRB15CBD0-1200-000000000

To ensure that the cover and the Outer band are delivered in the correct design and length, the following must be made known at the very least:

- Drive type (**S** = ball screw drive / **B** = belt)
- Product size (**15** = width 150 mm)
- Drive type (C = profile basis with ball screw and IP54 cover)
- Carriage version: (**0** = standard)
- Order Stroke (**1200** = 1200 mm)
- Homing switch (**0** = without)
- End switch (**0** = without)
- Assembly position switch (**0** = without End switch)

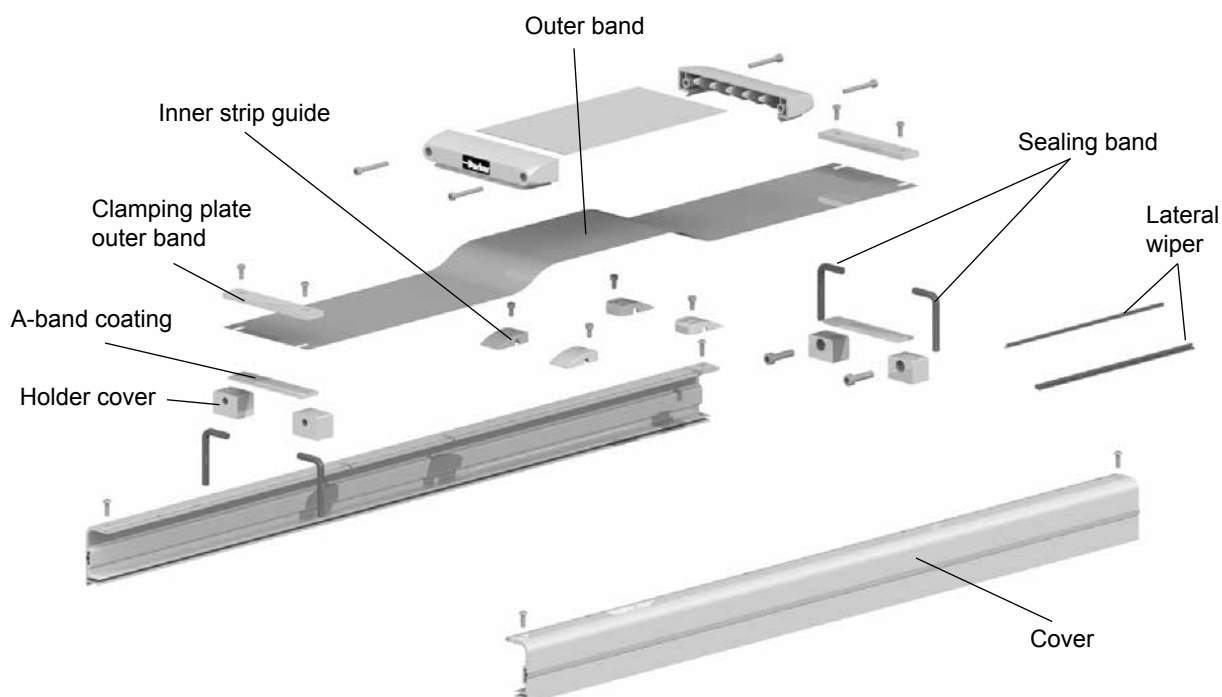

Order numbers for the IP54 cover	
Product size	Order number
HMRx08xxx0-xxxx-XXXxxxxxx	56123-XX-0...
HMRx11xxx0-xxxx-XXXxxxxxx	56124-XX-0...
HMRx15xxx0	56100-0...
HMRx18xxx0	56101-0...
HMRx24xxx0	56102-0...
HMRx08xxx1-xxxx-XXXxxxxxx, HMRx08xxx2-xxxx-XXXxxxxxx	56123-XX-1...
HMRx11xxx1-xxxx-XXXxxxxxx, HMRx11xxx2-xxxx-XXXxxxxxx	56124-XX-1...
HMRx15xxx1, HMRx15xxx2	56100-1...
HMRx18xxx1, HMRx18xxx2	56101-1...
HMRx24xxx1, HMRx24xxx2	56102-1...

Modular Electric HMR Linear Drives

11.2 Position Detection internal and external

For connecting up to a maximum of three magnetic switches, you will require the corresponding number of M8 mounted connectors.

Use, installation and connection are described in section 7.5 cont.

With the external position detection the solenoid switches are fixed in the groove of the cover profile. The IP54 cover is required for this.



M8 - Connector



T-slot switch

Order numbers for parts for internal position detection			
Designation	Order number		
M8 mounted connector	54519FIL		
Order numbers for parts for external position detection			
T-slot cable holder T-Nut, VP 5St	56350FIL		
M8 connector with cable 5 m	KL3186		
M8 connector with cable 10 m	KL3217		
M8 connector with cable 15 m	KL3216		
Position detection	extern	intern/extern	
Magnetschalter	M8 connector, snap in	FL = open lead	
	0.3 m	3 m	10 m
R2NO-I: Reed, 2-wire, normally open NO, internal	P8S-GRSHX	P8S-GRFAX	P8S-GRFDX
R2NC-I: Reed, 2-wire, normaly closed NC, internal	P8S-GESNX	P8S-GEFFX	P8S-GEFRX
P3NO-I: PNP, 3-wire, normally open NO, internal	P8S-GPSHX	P8S-GPFAX	P8S-GPFDX
P3NC-I: PNP, 3-wire, normaly closed NC, internal	P8S-GQSHX	P8S-GQFAX	P8S-GQFDX
N3NO-I: PNP, 3-wire, normally open NO, internal	P8S-GNSHX	P8S-GNFAX	P8S-GNFDX
N3NC-I: PNP, 3-wire, normaly closed NC, internal	P8S-GMSHX	P8S-GMFAX	P8S-GMFDX

12 Spare Part / Wearing Part Kits

12.1 Outer Band Package

If the outer band package needs to be replaced, the product key must be indicated.

Example: HMRS15C100-1200-000000000

Example: HMRB15CBD0-1200-000000000

To ensure that the outer cover is delivered in the correct design and length, the following must be made known at the very least:

- Product size (15 = width 150 mm)
- Carriage: (0 = Standard)
- Order Stroke (1200 = 1200 mm)

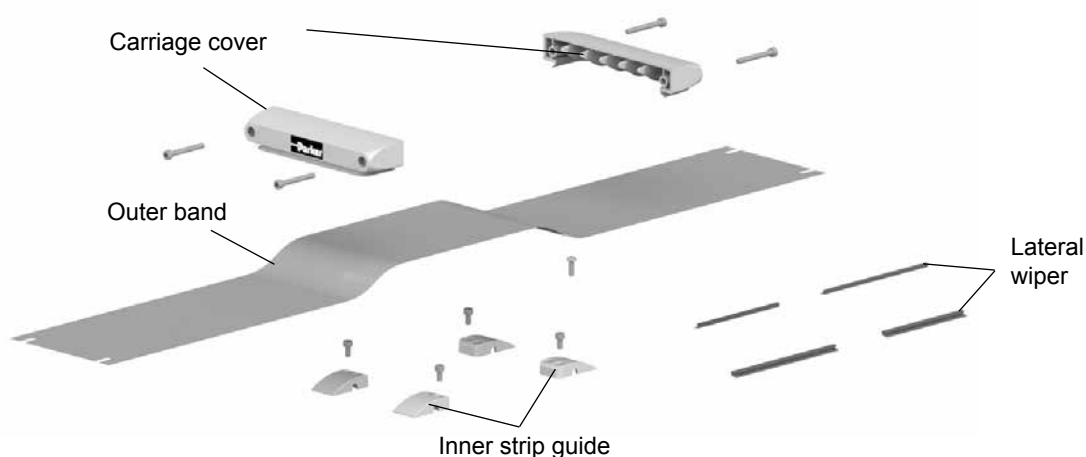

12.2 Outer Band

If the outer band needs to be replaced because of damage, the product key must be indicated.

Example: HMRS15C100-1200-000000000

Example: HMRB15CBD0-1200-000000000

To ensure that the outer band is delivered in the correct design and length, the following must be made known at the very least:

- Product size (15 = width 150 mm)
- Carriage version: (0 = Standard)
- Order Stroke (1200 = 1200 mm)

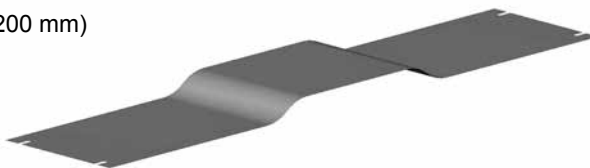

Order numbers for the outer band package		Order numbers for the outer band spare part	
Type of drive	Order number	Type of drive	Order number
HMRx08xxx0	56125-0...	HMRx08xxx0	56127-0...
HMRx11xxx0	56126-0...	HMRx11xxx0	56128-0...
HMRx15xxx0	56103-0...	HMRx15xxx0	56106-0...
HMRx18xxx0	56104-0...	HMRx18xxx0	56107-0...
HMRx24xxx0	56105-0...	HMRx24xxx0	56108-0...
HMRx08xxx1, HMRx08xxx2	56125-1...	HMRx08xxx1 or 2	56127-1...
HMRx11xxx1, HMRx11xxx2	56126-1...	HMRx11xxx1 or 2	56128-1...
HMRx15xxx1, HMRx15xxx2	56103-1...	HMRx15xxx1 or 2	56106-1...
HMRx18xxx1, HMRx18xxx2	56104-1...	HMRx18xxx1 or 2	56107-1...
HMRx24xxx1, HMRx24xxx2	56105-1...	HMRx24xxx1 or 2	56108-1...

12.3 Drive Type Ball Screw

If the drive type is to be replaced, the product key must be indicated.

Example: HMRS15C100-1200-000000000

To ensure that a suitable drive type can be delivered, the following must be known at the very least:

- Product size (**15** = width 150 mm)
- Spindle version (**10** = pitch 10 mm with plain shaft)
- Carriage: (**0** = Standard)
- Order Stroke (**1200** = 1200 mm)

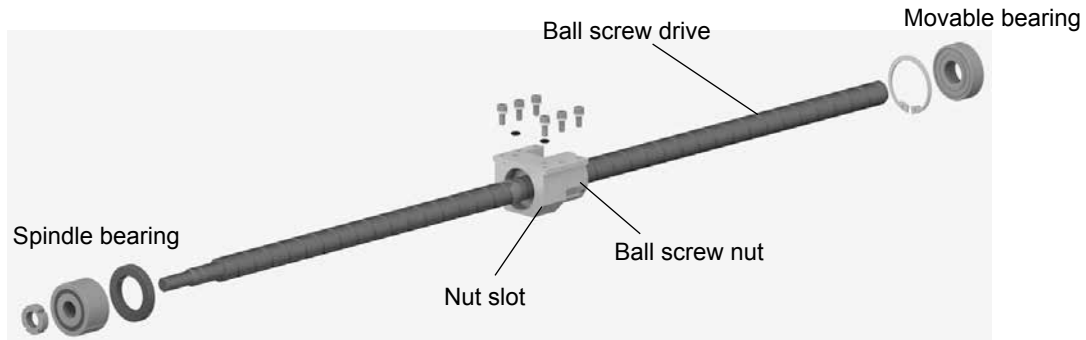

Order numbers for the ball screw		
Type of drive	Comments	Order number
HMRS08x05...	KGS 12X05-P	56129-...
HMRS08x12...	KGS 12X12-P	56130-...
HMRS11x05...	KGS 16X05-P	56131-...
HMRS11x16...	KGS 16X16-P	56132-...
HMRS15x05...	KGS 20X05-P	56109-...
HMRS15x20...	KGS 20X20-P	56110-...
HMRS18x10...	KGS 25X10-P	56111-...
HMRS18x25...	KGS 25X25-P	56112-...
HMRS24x10...	KGS 32X10-P	56113-...
HMRS24x32...	KGS 32X32-P	56114-...

12.4 Carriage Belt Drive

If the belt is to be replaced, the product key must be indicated.

Example: HMRB15CBD0-1200-000000000

To ensure that a suitable belt can be delivered, the following must be known at the very least:

- Product size (**15** = width 150 mm)
- Motor mounting position (**BD** = 090° front with double plain shaft)
- Carriage: (**0** = Standard)
- Order Stroke (**1200** = 1200 mm)



Order numbers belt		
Type of drive	Comments	Order number
HMRB08xxx0..., HMRB08xxx1...	Motor mounting 090/270, 000/180, 20AT3	56209-0...
HMRB11xxx0..., HMRB11xxx1...	Motor mounting 090/270, 000/180, 25RPP5	56210-0...
HMRB15xBD0..., HMRB15xDD0..., HMRB15xBD1..., HMRB15xDD1..."	Motor mounting 090/270, 40RPP5	56200-0...
HMRB15xAP0..., HMRB15xAD0..., HMRB15xAP1..., HMRB15xAD1..."	Motor mounting 000/180, 25RPP5	56201-0...
HMRB15xCP0..., HMRB15xCD0..., HMRB15xCP1..., HMRB15xCD1..."		
HMRB18xBD0..., HMRB18xDD0..., HMRB18xBD1..., HMRB18xDD1..."	Motor mounting 090/270, 50RPP5	56202-0...
HMRB18xAP0..., HMRB18xAD0..., HMRB18xAP1..., HMRB18xAD1..."	Motor mounting 000/180, 40RPP5	56203-0...
HMRB18xCP0..., HMRB18xCD0..., HMRB18xCP1..., HMRB18xCD1..."		
HMRB24xBD0..., HMRB24xDD0..., HMRB24xBD1..., HMRB24xDD1..."	Motor mounting 090/270, 75RPP8	56204-0...
HMRB24xAP0..., HMRB24xAD0..., HMRB24xAP1..., HMRB24xAD1..."	Motor mounting 000/180, 50RPP8	56205-0...
HMRB24xCP0..., HMRB24xCD0..., HMRB24xCP1..., HMRB24xCD1..."		

Order numbers belt BI-PART		
HMRB08xAP2..., HMRB08xAD2...	Motor mounting 000/180, 20AT3	56209-2...
HMRB08xCP2..., HMRB08xCD2...		
HMRB11xAP2..., HMRB11xAD2...	Motor mounting 000/180, 25RPP5	56210-2...
HMRB11xCP2..., HMRB11xCD2...		
HMRB15xAP2..., HMRB15xAD2...	Motor mounting 000/180, 25RPP5	56201-2...
HMRB15xCP2..., HMRB15xCD2...		
HMRB18xAP2..., HMRB18xAD2...	Motor mounting 000/180, 40RPP5	56203-2...
HMRB18xCP2..., HMRB18xCD2...		
HMRB24xAP2..., HMRB24xAD2...	Motor mounting 000/180, 50RPP8	56205-2...
HMRB24xCP2..., HMRB24xCD2...		

12.5 Carriage Ball Screw Drive

If a carriage ball screw drive is to be replaced, the product key must be indicated.

Example: HMRS15C100-1200-000000000

To ensure that a suitable carriage can be delivered, the following must be known at the very least:

- Drive type **S** = Ball screw drive
- Product size (**15** = width 150 mm)
- Carriage: (**0** = Standard)
- Order Stroke (**1200** = 1200 mm)

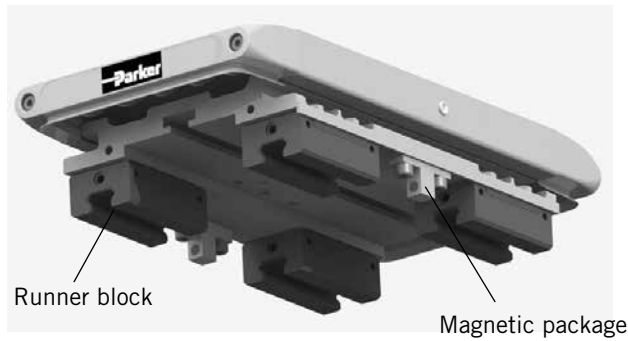

Order Numbers Carriage Ball Screw Drive		
Type of drive	Comments	Order number
HMRS08xxx0...	Standard	56133FIL
HMRS11xxx0...	Standard	56134FIL
HMRS15xxx0...	Standard	56115FIL
HMRS18xxx0...	Standard	56116FIL
HMRS24xxx0...	Standard	56117FIL
HMRS08xxx1...	Tandem	56211FIL
HMRS11xxx1...	Tandem	56212FIL
HMRS15xxx1...	Tandem	56206FIL
HMRS18xxx1...	Tandem	56207FIL
HMRS24xxx1...	Tandem	56208FIL

For version carriage tandem: 1x carriage Standard and 1x carriage Tandem necessary.

12.6 Carriage Belt Drive

If the carriage belt is to be replaced, the product key must be indicated.

Example: HMRB15CBD0-1200-000000000

To ensure that a suitable carriage can be delivered, the following must be known at the very least:

- Drive type **B** = Belt
- Product size (**15** = width 150 mm)
- Motor mounting position (**BD** = 090° front with double plain shaft)
- Carriage: (**0** = Standard)
- Order Stroke (**1200** = 1200 mm)

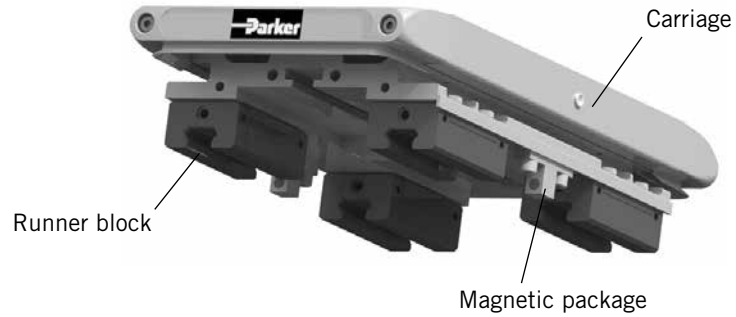

Order numbers carriage belt drive		
Type of drive	Comments	Order number
HMRB08xxx0..., HMRB08xxx1..., HMRB08xxx2...	Standard/Tandem/Bipart	56211FIL
HMRB11xxx0..., HMRB11xxx1..., HMRB11xxx2...	Standard/Tandem/Bipart	56212FIL
HMRB15xxx0..., HMRB15xxx1..., HMRB15xxx2...	Standard/Tandem/Bipart	56206FIL
HMRB18xxx0..., HMRB18xxx1..., HMRB18xxx2...	Standard/Tandem/Bipart	56207FIL
HMRB24xxx0..., HMRB24xxx1..., HMRB24xxx2...	Standard/Tandem/Bipart	56208FIL

For version tandem/Bipart: 2x carriage Standard necessary.

Modular Electric HMR Linear Drives

12.7 Drive Shafts Belt

If one of the drive shafts have to be replaced, the product key must be indicated.

Example: HMRB15CBD0-1200-000000000

To ensure that a suitable drive shaft can be delivered, the following must be known at the very least:

- Drive type **B** = Belt
- Product size (**15** = width 150 mm)
- Motor mounting position (**BD** = 090° front with double plain shaft) .

Plain shaft "P"



Double plain shaft "D"

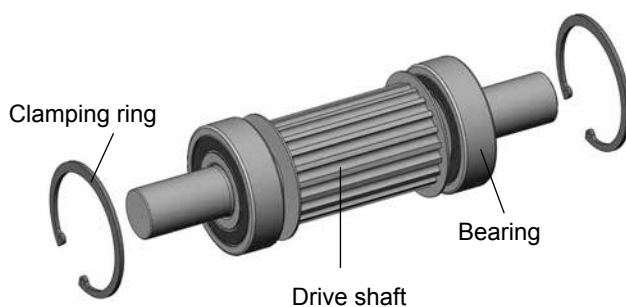

Non drive end shaft



Order numbers drive shaft belt drive		
Type of drive	Comments	Order number
HMRB08xBD..., HMRB08xDD...	Motor mounting 090/270, double plain shaft	56213FIL
HMRB08xAP..., HMRB08xCP...	Motor mounting 000/180, plain shaft	56214FIL
HMRB08xAD..., HMRB08xCD...	Motor mounting 000/180, double plain shaft	56213FIL
HMRB08xAP..., HMRB08xCP..., HMRB08xAD..., HMRB08xCD...	Motor mounting 000/180, non drive end shaft	56215FIL
HMRB11xBD..., HMRB11xDD...	Motor mounting 090/270, double plain shaft	56216FIL
HMRB11xAP..., HMRB11xCP...	Motor mounting 000/180, plain shaft	56217FIL
HMRB11xAD..., HMRB11xCD...	Motor mounting 000/180, double plain shaft	56216FIL
HMRB11xAP..., HMRB11xCP..., HMRB11xAD..., HMRB11xCD...	Motor mounting 000/180, non drive end shaft	56218FIL
HMRB15xBD..., HMRB15xDD...	Motor mounting 090/270, double plain shaft	56150FIL
HMRB15xAP..., HMRB15xCP...	Motor mounting 000/180, plain shaft	56151FIL
HMRB15xAD..., HMRB15xCD...	Motor mounting 000/180, double plain shaft	56152FIL
HMRB15xAP..., HMRB15xCP..., HMRB15xAD..., HMRB15xCD...	Motor mounting 000/180, non drive end shaft	56153FIL
HMRB18xBD..., HMRB18xDD...	Motor mounting 090/270, double plain shaft	56154FIL
HMRB18xAP..., HMRB18xCP...	Motor mounting 000/180, plain shaft	56155FIL
HMRB18xAD..., HMRB18xCD...	Motor mounting 000/180, double plain shaft	56156FIL
HMRB18xAP..., HMRB18xCP..., HMRB18xAD..., HMRB18xCD...	Motor mounting 000/180, non drive end shaft	56157FIL
HMRB24xBD..., HMRB24xDD...	Motor mounting 090/270, double plain shaft	56158FIL
HMRB24xAP..., HMRB24xCP...	Motor mounting 000/180, plain shaft	56159FIL
HMRB24xAD..., HMRB24xCD...	Motor mounting 000/180, double plain shaft	56160FIL
HMRB24xAP..., HMRB24xCP..., HMRB24xAD..., HMRB24xCD...	Motor mounting 000/180, non drive end shaft	56161FIL

12.8 Belt Tensioning Block

If the tensioning block is to be replaced, the product key must be indicated.

Example: HMRB15CBD0-1200-000000000

To ensure that a suitable tension block can be delivered, the following must be known at the very least:

- Drive type **B** = Belt
- Product size (**15** = width 150 mm)
- Motor mounting position (**BD** = 090° front double plain shaft)
- Carriage: (0 = Standard)

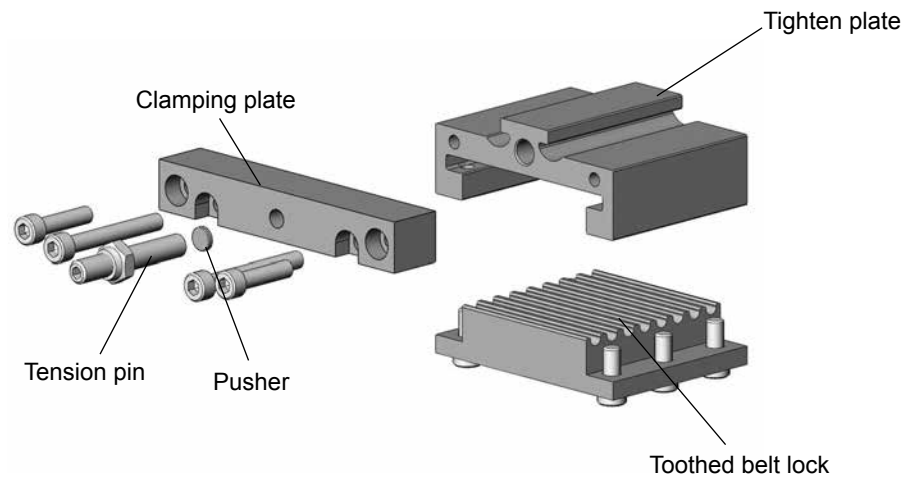

Order number tension block Belt Drive		
Type of drive	Comments	Order number
HMRB08xBD..., HMRB08xDD...	Motor mounting 090/270, Standard	56219FIL
HMRB08xAP..., HMRB08xCP..., HMRB08xAD..., HMRB08xCD...	Motor mounting 000/180, Standard/Bipart	56220FIL
HMRB11xBD..., HMRB11xDD...	Motor mounting 090/270, Standard	56221FIL
HMRB11xAP..., HMRB11xCP..., HMRB11xAD..., HMRB11xCD...	Motor mounting 000/180, Standard/Bipart	56222FIL
HMRB15xBD..., HMRB15xDD...	Motor mounting 090/270, Standard	56162FIL
HMRB15xAP..., HMRB15xCP..., HMRB15xAD..., HMRB15xCD...	Motor mounting 000/180, Standard/Bipart	56163FIL
HMRB18xBD..., HMRB18xDD...	Motor mounting 090/270, Standard	56164FIL
HMRB18xAP..., HMRB18xCP..., HMRB18xAD..., HMRB18xCD...	Motor mounting 000/180, Standard/Bipart	56165FIL
HMRB24xBD..., HMRB24xDD...	Motor mounting 090/270, Standard	56166FIL
HMRB24xAP..., HMRB24xCP..., HMRB24xAD..., HMRB24xCD...	Motor mounting 000/180, Standard/Bipart	56167FIL

12.9 Impact protection

If the impact protection is to be replaced, the product key must be indicated.

Example: HMRS**15**C100-1200-000000000

Example: HMRB**15**CBD**0**-1200-000000000

To ensure that a suitable impact protection can be delivered, the following must be known at the very least:

- Product size (**15** = width 150mm)
- Carriage: (0 = Standard)



Order number for impact protection	
Type of drive	Order number
HMRx08	56135FIL
HMRx11	56118FIL
HMRx15	56118FIL
HMRx18	56119FIL
HMRx24	56119FIL

13 Declaration of Incorporation



Parker Hannifin Manufacturing Germany GmbH & Co. KG
Pneumatic Division Europe – Origa
Industriestraße 8
70794 Filderstadt (Sielmingen)
Deutschland

Tel +49 (0)7158 1703-0
Fax +49 (0)7158 64870
info-origa-de@parker.com

www.parker-origa.com
www.parker.com

Ust.-Id.-Nr.: DE 277325745
Steuer-Nr. 349/5747/2105

Commerzbank AG
BLZ: 480 400 35
Konto: 7610371
IBAN: DE14 4804 0035 0761 0371 00
SWIFT: COBADEFF480

Declaration of Incorporation

in accordance with EU-Directives Machinery

The HMR High Moment Rodless part machine, in the form of power-operated Linear drives,

Products:	Screw Drive	Toothed Belt Drive
	HMRS08	HMRB08
	HMRS11	HMRB11
	HMRS18	HMRB18
	HMRS24	HMRB24

is developed, designed and manufactured in compliance with Guidelines 2006/42/EC and is the sole responsibility of

Company: **Parker Hannifin Manufacturing Germany GmbH & Co. KG**
Pneumatic Division Europe - Origa
Industriestraße 8 · 70794 Filderstadt (Sielmingen)

The following related standards apply:

- DIN EN ISO 12100, Safety of Applications Plant and Machinery
- DIN EN 60204.1, Equipment for Industrial Machines

Complete technical documentation is available.

Commissioning of the HMR High Moment Rodless linear drives is not permitted until it has been established that the complete machine/system corresponds to the provisions of the EC Machinery Directive.

Filderstadt, Juni 2013

ppa. Johann Asperger

i.V. Dr. Axel Frösche

Parker Worldwide

Europe, Middle East, Africa

AE – United Arab Emirates,
Dubai

Tel: +971 4 8127100
parker.me@parker.com

AT – Austria, Wiener Neustadt

Tel: +43 (0)2622 23501-0
parker.austria@parker.com

AT – Eastern Europe, Wiener
Neustadt

Tel: +43 (0)2622 23501 900
parker.easteurope@parker.com

AZ – Azerbaijan, Baku

Tel: +994 50 2233 458
parker.azerbaijan@parker.com

BE/LU – Belgium, Nivelles

Tel: +32 (0)67 280 900
parker.belgium@parker.com

BY – Belarus, Minsk

Tel: +375 17 209 9399
parker.belarus@parker.com

CH – Switzerland, Etoy

Tel: +41 (0)21 821 87 00
parker.switzerland@parker.com

CZ – Czech Republic, Klecany

Tel: +420 284 083 111
parker.czechrepublic@parker.com

DE – Germany, Kaarst

Tel: +49 (0)2131 4016 0
parker.germany@parker.com

DK – Denmark, Ballerup

Tel: +45 43 56 04 00
parker.denmark@parker.com

ES – Spain, Madrid

Tel: +34 902 330 001
parker.spain@parker.com

FI – Finland, Vantaa

Tel: +358 (0)20 753 2500
parker.finland@parker.com

FR – France, Contamine s/Arve

Tel: +33 (0)4 50 25 80 25
parker.france@parker.com

GR – Greece, Athens

Tel: +30 210 933 6450
parker.greece@parker.com

HU – Hungary, Budapest

Tel: +36 23 885 470
parker.hungary@parker.com

IE – Ireland, Dublin

Tel: +353 (0)1 466 6370
parker.ireland@parker.com

IT – Italy, Corsico (MI)

Tel: +39 02 45 19 21
parker.italy@parker.com

KZ – Kazakhstan, Almaty

Tel: +7 7272 505 800
parker.easteurope@parker.com

NL – The Netherlands, Oldenzaal

Tel: +31 (0)541 585 000
parker.nl@parker.com

NO – Norway, Asker

Tel: +47 66 75 34 00
parker.norway@parker.com

PL – Poland, Warsaw

Tel: +48 (0)22 573 24 00
parker.poland@parker.com

PT – Portugal, Leca da Palmeira

Tel: +351 22 999 7360
parker.portugal@parker.com

RO – Romania, Bucharest

Tel: +40 21 252 1382
parker.romania@parker.com

RU – Russia, Moscow

Tel: +7 495 645-2156
parker.russia@parker.com

SE – Sweden, Spånga

Tel: +46 (0)8 59 79 50 00
parker.sweden@parker.com

SK – Slovakia, Banská Bystrica

Tel: +421 484 162 252
parker.slovakia@parker.com

SL – Slovenia, Novo Mesto

Tel: +386 7 337 6650
parker.slovenia@parker.com

TR – Turkey, Istanbul

Tel: +90 216 4997081
parker.turkey@parker.com

UA – Ukraine, Kiev

Tel +380 44 494 2731
parker.ukraine@parker.com

UK – United Kingdom, Warwick

Tel: +44 (0)1926 317 878
parker.uk@parker.com

ZA – South Africa, Kempton Park

Tel: +27 (0)11 961 0700
parker.southafrica@parker.com

North America

CA – Canada, Milton, Ontario

Tel: +1 905 693 3000

US – USA, Cleveland

Tel: +1 216 896 3000

Asia Pacific

AU – Australia, Castle Hill

Tel: +61 (0)2-9634 7777

CN – China, Shanghai

Tel: +86 21 2899 5000

HK – Hong Kong

Tel: +852 2428 8008

IN – India, Mumbai

Tel: +91 22 6513 7081-85

JP – Japan, Tokyo

Tel: +81 (0)3 6408 3901

KR – South Korea, Seoul

Tel: +82 2 559 0400

MY – Malaysia, Shah Alam

Tel: +60 3 7849 0800

NZ – New Zealand, Mt Wellington

Tel: +64 9 574 1744

SG – Singapore

Tel: +65 6887 6300

TH – Thailand, Bangkok

Tel: +662 186 7000-99

TW – Taiwan, Taipei

Tel: +886 2 2298 8987

South America

AR – Argentina, Buenos Aires

Tel: +54 3327 44 4129

BR – Brazil, Sao Jose dos Campos

Tel: +55 800 727 5374

CL – Chile, Santiago

Tel: +56 2 623 1216

MX – Mexico, Apodaca

Tel: +52 81 8156 6000

European Product Information Centre

Free phone: 00 800 27 27 5374

(from AT, BE, CH, CZ, DE, DK, EE, ES, FI,
FR, IE, IL, IS, IT, LU, MT, NL, NO, PL, PT, RU,
SE, SK, UK, ZA)

Parker Hannifin Manufacturing Germany GmbH & Co. KG Pneumatic Division Europe – Origa

Industriestraße 8

70794 Filderstadt, Germany

Tel: +49 (0)7158 1703-0

Fax: +49 (0)7158 64870

E-Mail: info-origa-de@parker.com

www.parker-origa.com

www.parker.com

