

Amphenol Line Replaceable Module (LRM)

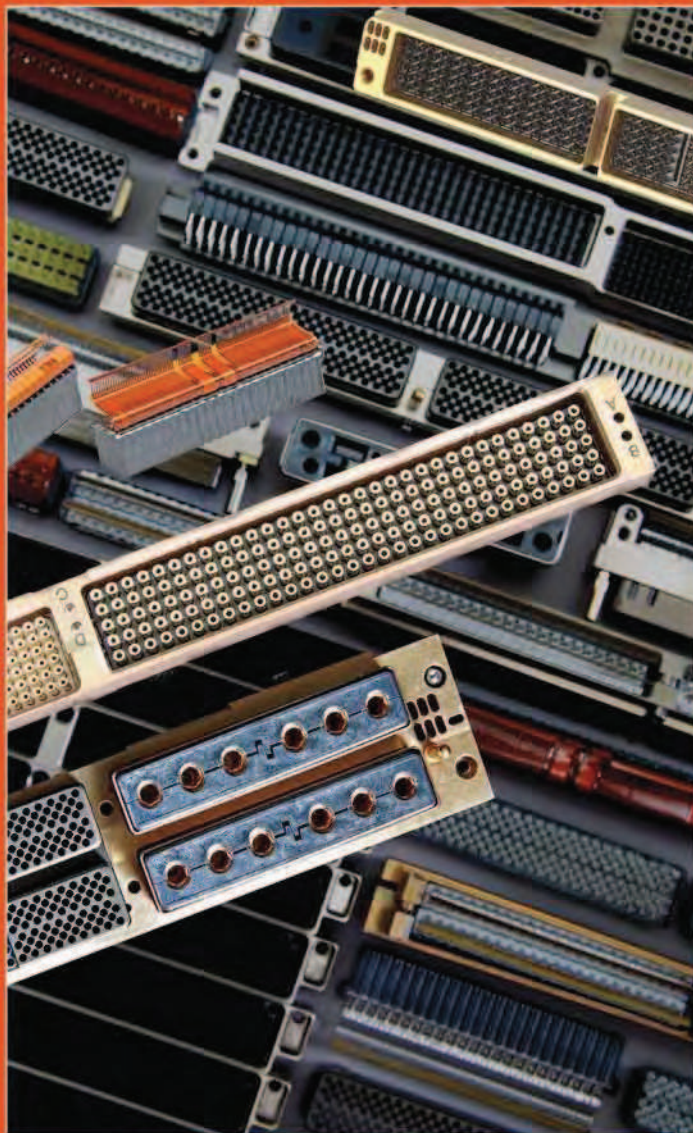

TABLE OF CONTENTS

Amphenol LRM Interconnects

- Table of Contents 8
- Introduction - LRM Styles and Design Flexibility. 9
- LRM Product Evolution 10, 11
- Amphenol Leads in Board Level Technology 12, 13
- LRM Module Connector General Information 14
- LRM Backplane Connector General Information 15

Staggered Grid LRM

- Staggered Grid LRM and Staggered Grid Airflow-thru Contact Patterns/Comparison 16, 17
- Staggered Grid Arrangements 18, 19
- Staggered Grid Airflow-thru Arrangements and Custom Shells 20
- Staggered Grid Termination Options 21
- Staggered Grid Performance, Materials 22

GEN-X Grid LRM

- Comparison of Staggered Grid LRM vs GEN-X LRM. 23, 24
- GEN-X Pattern, Arrangements 25

LRM Interconnect Options - Fiber Optics / High Speed / RF / High Power

- Fiber Optics 26, 27
- RF Modules, LRMs with High Speed Contacts 28
- Power Supply Modules, LRMs with RADSOK® 29
- Hi-Speed Gigastak™, Digastak™ LRMs and cStack™ Technology. 30, 35

Other LRM Options, Accessories, Tools, VME, VITA & VIPER Interconnects

- Flex Circuitry, Backplanes with Compliant Pins, I/O Modules with PC Tails. 36
- Electrostatic Discharge (ESD) Protection 37
- LRM Accessories and Tools 38, 39
- Ruggedized VME64x Interconnects 40
- VME P0/J0 & VITA-66.1 Interconnects 41
- VIPER® Hi-Speed, High Density Interconnects 42, 43

Aid in Selection/Ordering of LRM/LRU

- Interconnects from Amphenol 44



LRM Typical Markets:

- Military & Commercial Avionics
- Military Vehicles
- Missiles/Ordnance
- Missile Defense
- C4ISR
- Space (Satellites)
- Radar



Amphenol® Line Replaceable Module (LRM) High Performance Board Level Interconnects



INTRODUCTION - LRM STYLES & DESIGN FLEXIBILITY

Staggered Grid LRM

High contact density in SEM-E and custom form factors



GEN-X Grid LRM

Higher contact density and improved electrical performance

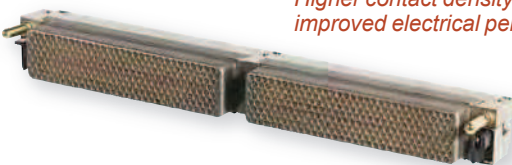

High Speed LRM

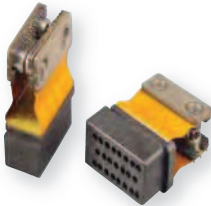

Inserts with 3.125 Gb/s and 6.25 Gb/s data rate capability, with flex termination. Can be added to existing LRM configurations.

LRM INTERCONNECTS FEATURE AMPHENOL'S BRUSH CONTACT TECHNOLOGY

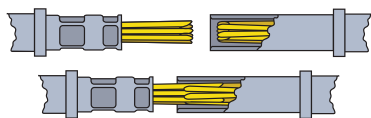

Multiple strands of high tensile strength wire bundled together to form brush-like contacts. See the Introduction & Brush Contact Technology section of this catalog for further description.

- With its low mating force, stable electrical performance and extended service life, the B³ Brush contact is the standard contact for the LRM.
- Digital (Brush) inserts can be combined with each other or with inserts for power, RF, fiber optic and high speed contacts.

ALSO COVERED IN THIS CATALOG SECTION - RUGGEDIZED VME64X INTERCONNECTS

Module and backplane connectors that meet more rugged harsh environment applications for VME64x cards



Amphenol® LRM Surface Mount Connectors meet the high density needs of today's integrated electronic modules.

Amphenol goes beyond the usual board level product offering: and that is what you would expect from a worldwide interconnect product leader.

MODULAR AVIONICS ARCHITECTURAL POSSIBILITIES

With its flexibility in design, Amphenol LRM interconnects are capable of meeting the wide variety of user requirements for a board mount connector.

- Thousands of combinations of inserts are possible - tailored to meet user needs
- LRM interconnects can be designed in 1, 2, 3 (and more) bay configurations with many shell designs available
- LRM digital (brush) inserts can be combined with inserts for power, fiber optics, RF, high speed and high amperage RADSOK® contacts

DESIGN FLEXIBILITY

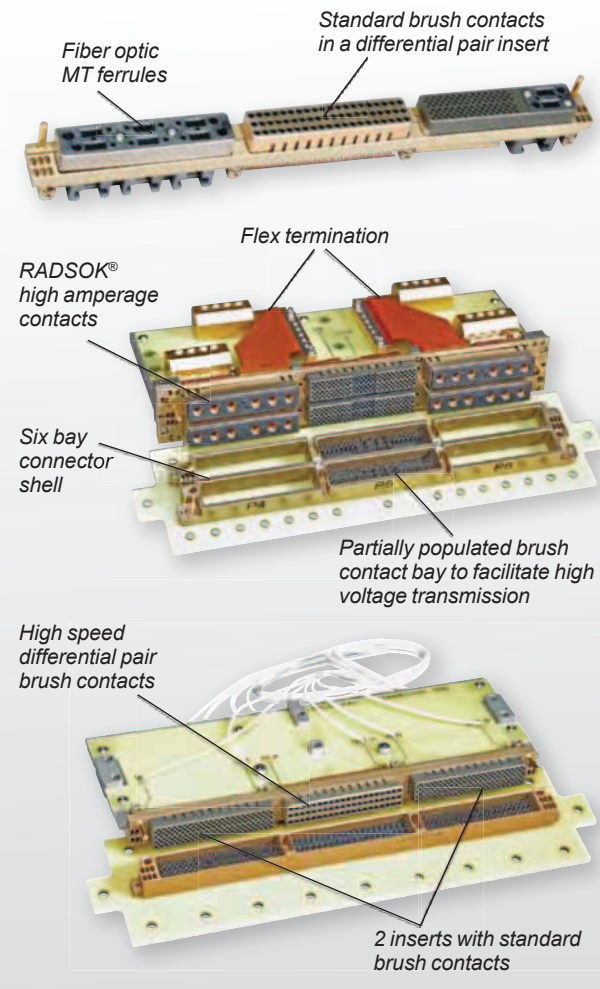

Introduction/
Pig-Solutions/
Brush Contact

Staggered/
GEN-X

Fiber Optics/
HiSpeed/RF/Power

Other Options/Access/
VME/VITA(VIPER)

High Density
HD33
HSB3
Hi-Speed

Low Mating Force MIL-DTL-55302
Standard
Brush
Hybrid - Signal/Power/
Coax/Fiber Optics

Docking Conn./
Accessories/Install.

Rack & Panel
Brush
Ruggedized

LMD/LMS
Rectangular
Interconnects

Other
Rectangular
Interconnects

NOTE: This catalog section supersedes Amphenol's older individual catalog on LRM products, 12-037.

LRM PRODUCT EVOLUTION

Introduction/
Pkg. Solutions/
Brush Contact

LRM (Line Replaceable Modules)
Staggered/
GEN-X
Fiber Optics/
Hi Speed/RF/Power
Other Options/Access./
VME/VITA(VIPER)

High Density
HDB3
HSB3
Hi Speed

Low Mating Force MIL-DTL-55302
Docking Conn./
Accessories/Install.
Hybrids - Signal/Power/
Coax/Fiber Optics
Standard
Brush

Rack & Panel
Brush
Ruggedized

LMD/LMS
Rectangular
Interconnects

Other
Rectangular
Interconnects

Amphenol has been committed to keeping pace with the ever-changing demands of the rectangular connector marketplace. Starting with the development of the B3 contact, incorporated into the low mating force PCB connectors, and later with the development of the line replaceable module (LRM), Amphenol has led the way in the avionics packaging industry for high quality rectangular products. This page and the following page give an overview of the rectangular product evolution.

Low Mating Force Connector with Bristle Brush Contacts*

- Developed in the 1980's to provide solutions to problems caused by the high mating and unmating forces of conventional pin and socket contact pairs.
- 4 Body styles: mother board (MB), daughter board (DB), PC connector, input/output connector
- Molded of thermoplastic material
- 2, 3 and 4 row configurations, 10 to 100 contacts per row in one contact row increments
- 100 inch center to center contact spacing, square grid
- Qualified to MIL-DTL-55302/166, /167, /168, /170

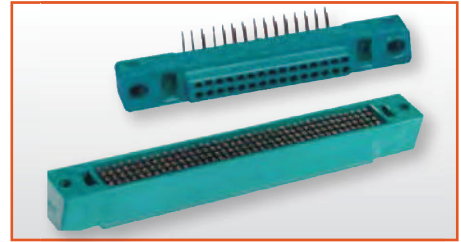

Low Mating Force Connectors - the first development of rectangulars with Brush contacts.

Line Replaceable Module (LRM) Connectors with Chevron Grid**

- Developed to meet the avionics packaging requirements for a surface mount, high contact density PCB connector in a SEM-E form factor.
- Digital insert pattern grid: 6 rows, 0.075" spacing along rows, 0.075" between rows with 0.025" offset.

** This is an older design of the LRM and is typically not used today. Staggered and GEN-X designs have replaced the Chevron design (Consult Amphenol for further details)

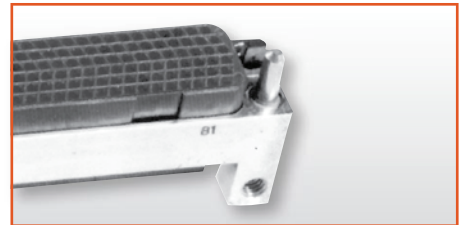

LRM Chevron Grid (150+180 contact pattern) (Amphenol's first LRM design)

LRM Connectors with Staggered Grid

- Advanced design to provide higher contact density for high speed integrated circuitry in SEM-E and custom form factors.
- Digital insert pattern grid is in 8 rows: 0.100 inch spacing along the row with 0.050 inch between rows, rows offset 0.050 inch. Typical standard arrangements would have 80 or 108 or 152 or 180 digital brush contacts.
- Options include various shell designs options to accommodate a wide range of PC board/heat sink combinations
- Surface mount termination on module connectors, PCB or compliant termination on backplane connectors
- Amphenol ESD protection (in module connector)
 - Designed for level 2 (flight line) maintenance
- Provides routing channels for backplane



LRM Staggered Grid (180 contact pattern) Amphenol's higher density LRM with more advantages.

Amphenol Staggered Grid Connectors are the connector of choice for the F-16 and F-22 Aircraft. The following were the criteria that determined the selection of the connector for the F-16, F-22 and F-35 aircraft:

- Reliability: Impervious to fretting corrosion, Micro-arching
- ESD Protection



Staggered Grid LRM was chosen for the F-16 and F-22 Aircraft

Amphenol LRM Evolution continues on next page.

* See the Brush Contact Technology section, and the Low Mating Force MIL-DTL-55302 section of this catalog.

LRM PRODUCT EVOLUTION, CONTINUED

Certainly not standing still, and continuing to expand product offering, Amphenol now provides LRMs with higher contact densities, special purpose configurations and high speed inserts.

LRM Connectors with GEN-X Grid

- Higher contact density and improved electrical performance
- All the features of staggered LRM, including ESD protection (module connector)
- Available in SEM-E and custom form factors
- 236 contact pattern grid in 8 rows: 0.075 inch spacing along the row with 0.060 inch between rows, rows offset 0.0375 inch

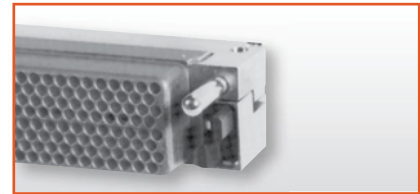

LRM GEN-X Grid (236 contact pattern)
Even higher densities with all the benefits of the Staggered Grid.

LRM Staggered Grid Airflow-thru Connectors

- LRM Staggered Airflow-thru inserts are available for wider board packages up to 0.425 in. These accommodate standard B³ tails in staggered pattern, but with increased spacing in the center, to accommodate airflow through heatsinks



LRM Staggered Grid Airflow-thru

LRM Connectors with Fiber Optics

- Custom combinations of digital contacts and fiber optic termini were offered as the product line further developed in the '90's.
- Configurations included:
 - MIL-T-29504/4, /5, /14 & /15 termini
 - MT ferrule arrangements (2-24 fiber lines per ferrule)

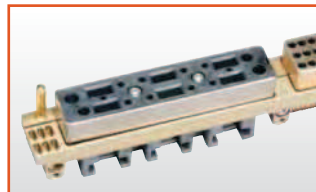

LRM with Fiber Optic MT Ferrules



LRM with RF Contacts

LRM Connectors to Accommodate RF Contacts

- LRM inserts are available with RF contacts:
 - Size 16 M39029/79 & /80 shielded contacts
 - Size 12 coax for DC-2 GHz; size 8 coax for DC-32 GHz
 - SMPM coax contacts*

LRM Power Supply Modules

- Custom designs of LRMs have been developed with 270VDC sections which are capable of providing corona-free operation at 100,000 feet. They utilize size 22D contacts and are available in both crimp and compliant pin terminations.

LRM with High Amperage RADSOK® Contacts

- The RADSOK® contact technology enables high current flow with minimal voltage loss and low insertion force



LRM backplane (left) and module connector (right) incorporating high amperage RADSOK® contacts (crimp style shown).

Board Level Interconnects of 2010 and Beyond -

More and more the customer has demanded a high level of flexibility, with designs that incorporate higher speeds and special features going beyond the standard LRM.

Configurations such as:

- High speed GigaStak® LRM connectors - capable of data rates up to 6.25 Gb/s, and DigiStak® LRM connectors capable of data rates up to 3.125 Gb/s
- High speed shielded contacts - coax, triax, twinax, differential twinax, and quadrx contacts available in inserts of the LRM
- Combinations of power contacts, standard brush, high power, differential pair brush, and fiber optic termini
- Incorporation of Flex Circuits for more versatility of PC board terminations
- Custom shells with multiple bay configurations, special keying components or special guide/ground pins
- Compliant pin contacts for press-fit termination to circuit boards.



High Speed GigaStak®, capable of data rates of 6.250 Gbps

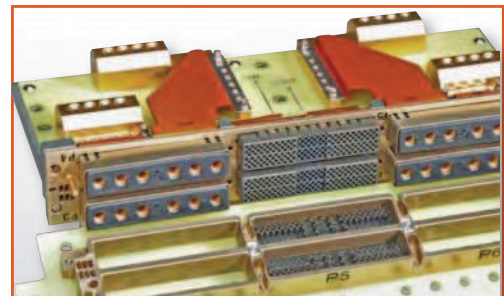

LRM special 6 bay design with RADSOK® contacts, standard brush contacts, and flex circuitry termination to module circuit card assemblies

Amphenol Backplane Capabilities

Amphenol backplanes incorporate a wide range of our interconnects. See *Other Rectangular Interconnects Section of this catalog, page 115, for more information on Amphenol backplanes.*

* See Other Rectangular Interconnects Section, page 124 for more information on SMPM contacts.

Introduction/
Pig-Solutions/
Brush Contact

Suggested/
GEN-X

Fiber Optics/
HiSpeed/RF/Power

Other Options/Access/
VME/VITA(VIPER)

High Density
HD33
HSB3
Hi Speed

Low Mating Force MIL-DTL-55302
Standard Brush
Hybrid - Signal/Power/
Coax/Fiber Optics

Docking Conn./
Accessories/Install.

Rack & Panel
Brush
Ruggedized

LMD/LMS
Rectangular
Interconnects

Other
Rectangular
Interconnects

Introduction/
Pkg. Solutions/
Brush Contact

LRM (Line Replaceable Modules)
Staggered/
GEN-X

Fiber Optics/
Hi Speed/RF/Power

Other Options/Access./
VME/VITA(VIPER)

High Density
HDB3
HSB3
Hi Speed

Low Mating Force MIL-DTL-55302
Standard
Brush

Hybrids - Signal/Power/
Coax/Fiber Optics

Docking Conn./
Accessories/Install.

Rack & Panel
Brush
Ruggedized

LMD/LMS
Rectangular
Interconnects

Other
Rectangular
Interconnects

We take pride that Amphenol Aerospace is the undisputed leader in interconnect systems for aerospace/harsh environment applications. Such applications require a high degree of engineering sophistication and precision manufacturing capability that only a company that has been in the interconnection product design and manufacturing business for over 50 years can offer.

We have earned the reputation as the leader in the military electrical connection arena especially for military cylindrical connectors, and are fast becoming the leader for rectangular and surface mount interconnects.

Our LRM and VME64x* products are used on major programs that include the following and more:

- F-35
- F-16
- F-15
- F/A-22
- F/A-18
- B2
- JTRS
- M1A2 Tank
- F-117
- AH-64 APACHE
- ASRAAM
- B52
- EA18G
- EA6B
- MEADS
- G/ATOR
- EQ-36

Expert design and applications engineering provides solid modeling and full Pro-Engineer® capabilities to develop new interconnection designs and perform structural analysis. Marketing product managers team with skilled engineers and production specialists in a customer-driven approach to produce the end result: defect-free parts, cost effectiveness, shorter lead and delivery times, and satisfied customers.

The photo top right shows the CST Microwave Studio® signal integrity modeling and simulation software at Amphenol. This state-of-the-art technology allows characterization of current connector designs and rapidly aids in the development of new high speed signal designs. It consists of a 3D, full-wave electromagnetic field solver for simulating electrical performance, producing SPICE models and eye diagrams.

Amphenol's capability for testing of it's wide range of cylindrical and rectangular connector products also includes vibration and shock testing, humidity, engagement/separation force evaluation, durability testing, as well as salt spray/fog, corona, ESD, optical performance testing and altitude simulation.

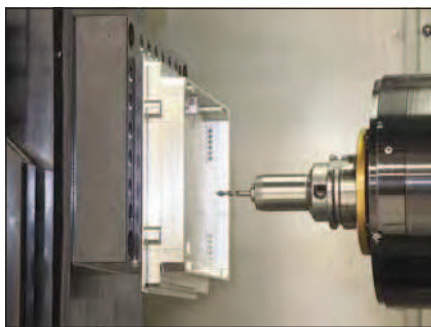

Close-up photo showing vertical machining of heatsink housings done at Amphenol.

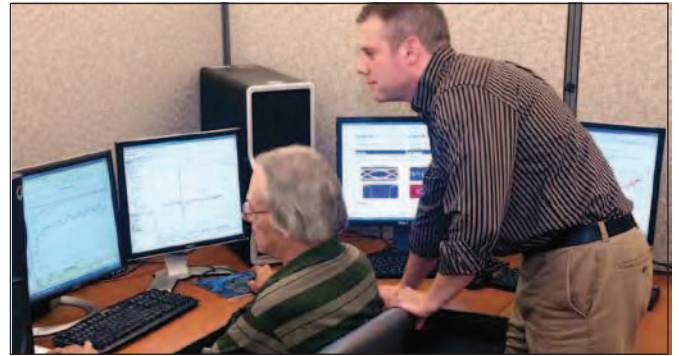

Engineers working at the signal integrity modeling and simulation software suite at Amphenol Aerospace Operations. (See page 28 for more information on Amphenol's testing of Hi-Speed LRM connectors).



Above and below are production areas for LRM interconnects and heatsinks. Note the orange balls on the machines - these are used as a quick checking device for processes.

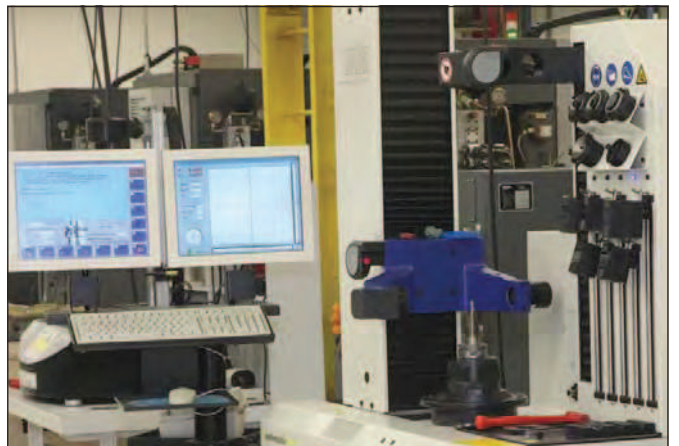

* VME64x products are covered on page 40.

Amphenol Leads in Board Level Technology



LRM MANUFACTURING EXPERTISE

Amphenol Aerospace is highly integrated to design, manufacture, assemble and ship an extensive variety of line replaceable module and backplane connectors. We also supply a wide range of heatsink hardware associated with this type of connector. The photo on right shows several heatsink forms used in the manufacture of LRM interconnects. For more information on heatsinks, see the Other Board Level and Rectangular Interconnects Section, pages 110 & 111.

Manufacturing equipment photos shown below demonstrate Amphenol's high technology capability. Focus is always on cost effective production and continuous improvement of processes. Manufacturing capabilities include state-of-the-art robotically controlled milling machines and CNC machining, as well as impact and extruding, plating, screw machining, and process control.

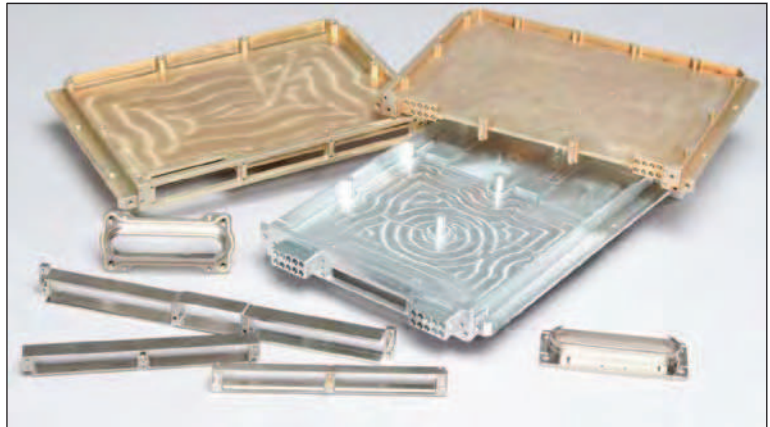

Variety of heatsinks and connector shells manufactured by Amphenol.

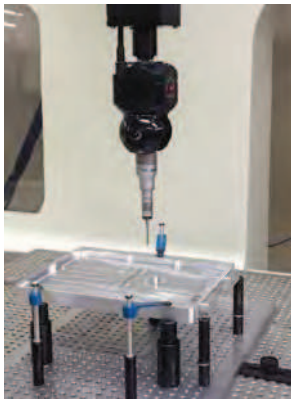

CMM measuring is done to check machined parts.

THE ADVANTAGE OF AMPHENOL'S WIDE DIVISIONAL CAPABILITY

Amphenol divisions work together to provide a very broad manufacturing capability for board level interconnects:

- Amphenol Aerospace (AAO)* has leading expertise in the production of line replaceable module inter-connects, VME64x interconnects and low mating force brush connectors.
- Amphenol Backplane Systems (ABS)** has leading expertise in the manufacture of custom backplane assemblies - high density, ruggedized, board to backplane interconnects.
- Amphenol Printed Circuits (APC)*** has leading expertise in the manufacture of flex circuitry products used in connector-to-board attachment.

These companies of Amphenol Corporation combine to provide design, applications engineering, fabrication, value-added assembly and testing to meet customer requirements as well as to develop products for emerging technologies.

* This catalog covers the rectangular interconnect products offered by AAO division. Go online at www.amphenol-aerospace.com to see the wide range of cylindrical and other interconnect products offered by AAO. And see the Other Rectangular Products section at the end of this catalog for other Amphenol divisions offerings of rectangular interconnects.

** For more information on backplane assemblies: page 115 and online at www.amphenol-abs.com.

*** For more information on flex circuit products: page 119 and online at www.amphenolapc.com.



Amphenol's high technology computer driven equipment for manufacturing heatsinks.



Checking for dimensional accuracy of LRM parts and heatsinks.

Introduction/
Pkg. Solutions/
Brush Contact

Suggested/
GEN-X

Fiber Optics/
HiSpeed/RF/Power

Other Options/Access/
VME/VITA(VIPER)

High Density
HD3
HSB3
Hi Speed

Low Mating Force MIL-DTL-55302
Standard
Brush
Hybrid - Signal/Power/
Coax/Fiber Optics

Docking Conn./
Accessories/Install.

Rack & Panel
Brush
Ruggedized

LMD/LMS
Rectangular
Interconnects

Other
Rectangular
Interconnects

STAGGERED GRID DOUBLE BAY SHOWN

The following is the LRM Module Connector identification and naming convention. The illustration is a double bay module with a staggered grid pattern.

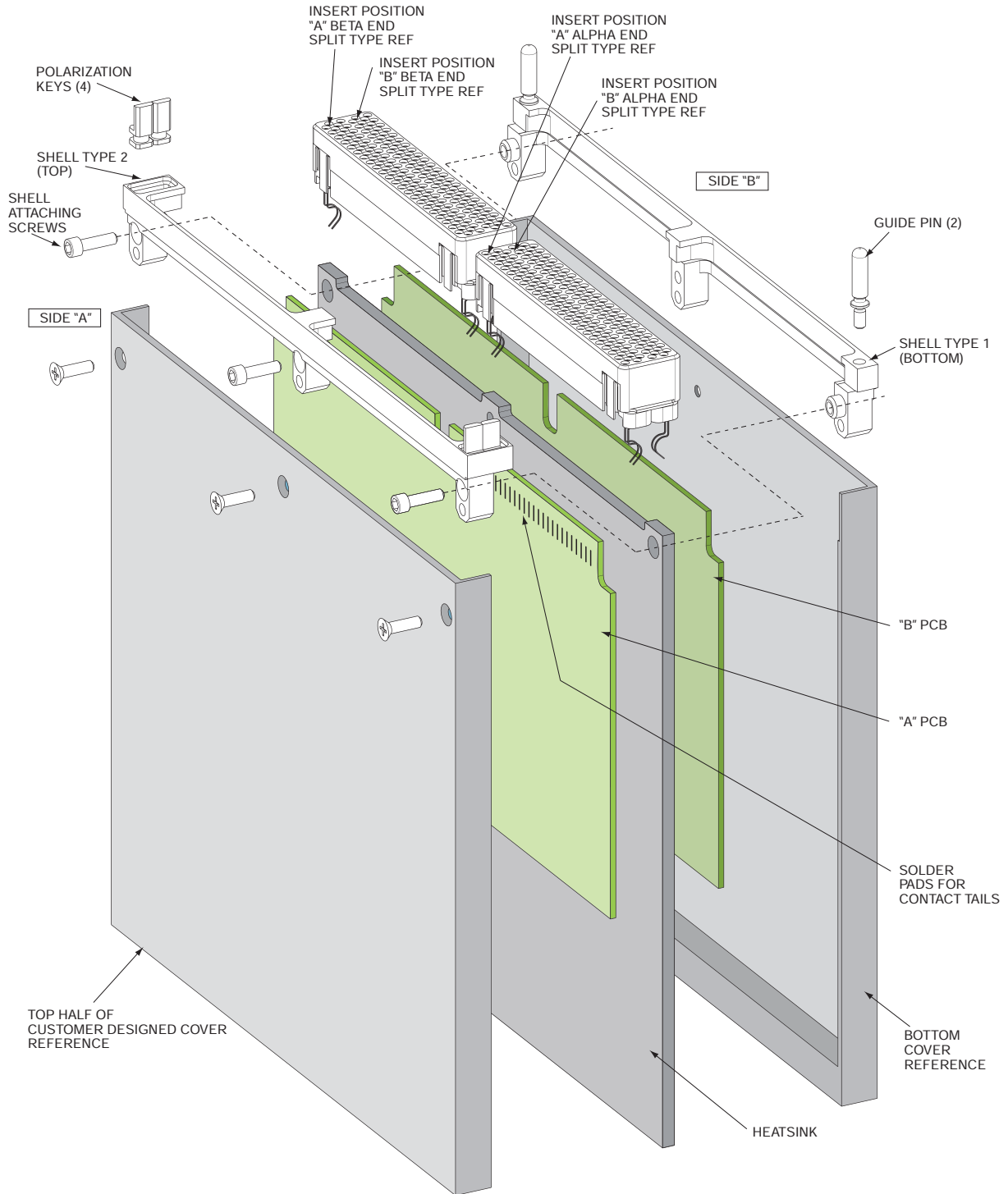
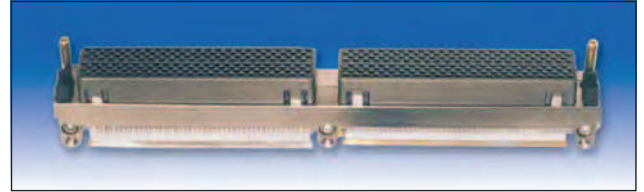

Introduction/
Pkg. Solutions/
Brush Contact

LRM (Line Replaceable Modules)
Staggered/
GEN-X
Fiber Optics/
Hi Speed/RF/Power
Other Options/Access./
VME/VITA(VIPER)

High Density
HSB3
Hi Speed
HDB3

Low Mating Force MIL-DTL-55302
Docking Conn./
Accessories/Install.
Hybrids - Signal/Power/
Coax/Fiber Optics
Standard
Brush

Rack & Panel
Brush
Ruggedized

LMD/LMS
Rectangular
Interconnects

Other
Rectangular
Interconnects

LRM Backplane Connector General Information



STAGGERED GRID DOUBLE BAY SHOWN

The following diagram shows an exploded view of an LRM staggered grid backplane connector in a two bay configuration.

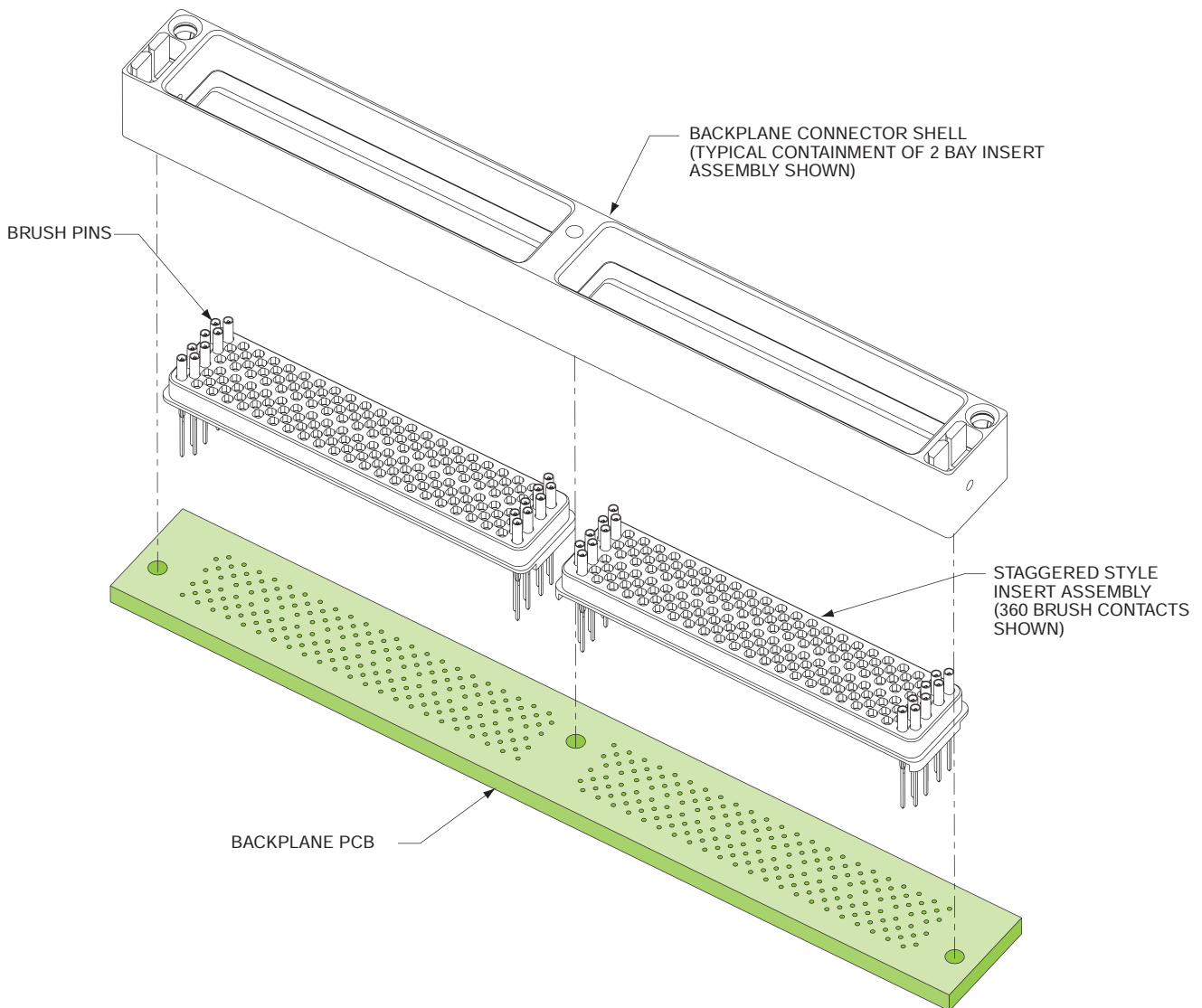
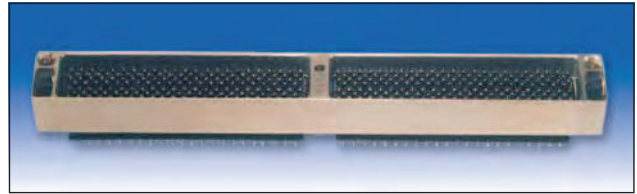

Introduction/
Pig. Solutions/
Brush Contact

LRM (Line Replaceable Modules)
Staggered/
GEN-X
Fiber Optics/
HiSpeed/Rf/Power
Other Options/Access/
VME/VITA(VIPER)

High Density
HD33
HSB3
Hi Speed

Low Mating Force MIL-DTL-55302
Standard
Brush
Hybrid - Signal/Power/
Coax/Fiber Optics
Docking Conn./
Accessories/Install.

Rack & Panel
Brush
Ruggedized

LMD/LMS
Rectangular
Interconnects

Other
Rectangular
Interconnects

CONTACT PATTERNS

Introduction/
Pkg. Solutions/
Brush Contact

LRM (Line Replaceable Modules)
Other Options/Access./
VME/VITA(VIPER)

Fiber Optics/
Hi Speed/RF/Power
GEN-X

High Density
HSB3
Hi Speed

Low Mating Force MIL-DTL-55302
Docking Conn./
Accessories/Install.

Rack & Panel
Brush
Ruggedized

LMD/LMS
Rectangular
Interconnects

Other
Rectangular
Interconnects

STAGGERED GRID DESCRIPTION

The LRM standard staggered grid pattern employs surface mount leads on .025 inch centerlines (pitch). Insert patterns of digital brush contacts are in 80, 108, 152 and 180 contact counts. See typical arrangement drawings on pages 18 and 19.

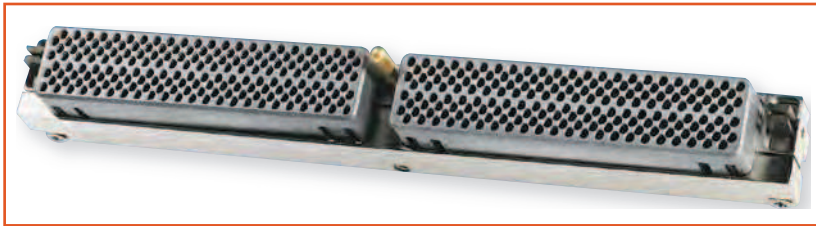
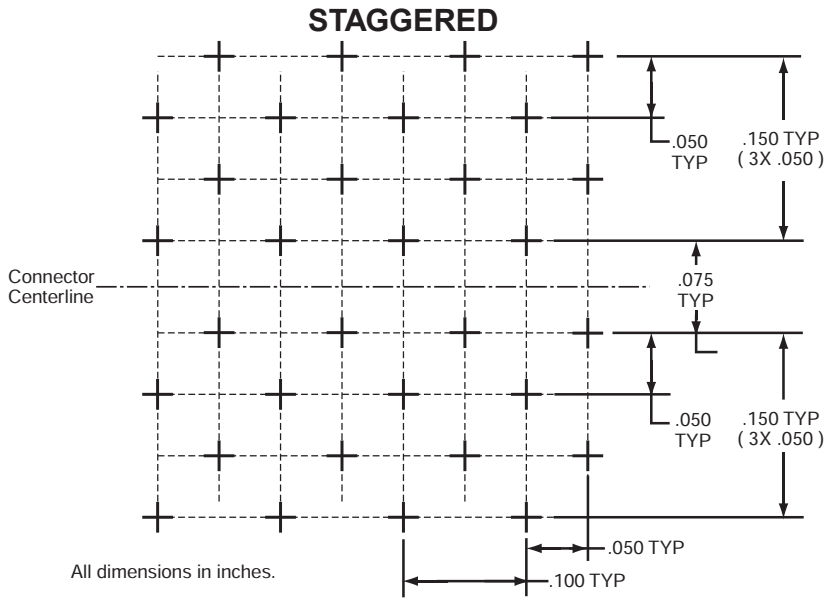

Two bay, 360 contact, module connector with standard staggered grid pattern

STAGGERED AIRFLOW-THRU GRID DESCRIPTION

The staggered grid airflow-thru inserts were designed to accommodate wider board packaging and airflow-thru heatsinks. Insert patterns of digital brush contacts are same as the staggered grid pattern (80, 108, 152 and 180 contact counts). See typical arrangement drawings on page 20.

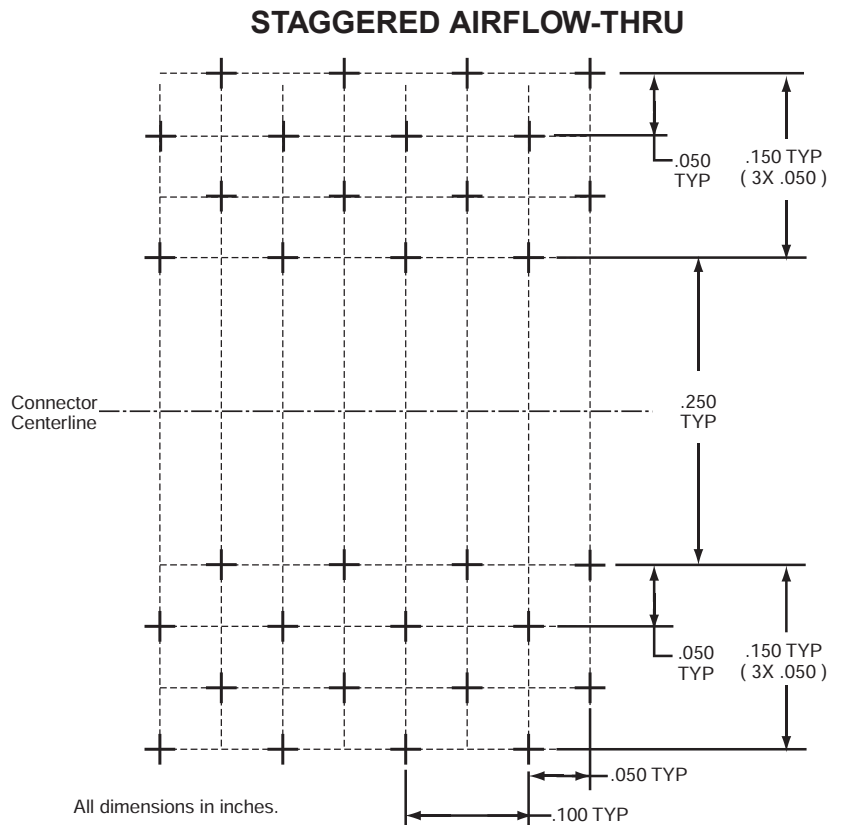

Staggered grid airflow-thru backplane insert.

CONTACT PATTERNS/COMPARISON

Staggered Grid (Standard)

Staggered Grid for Standard Board Packages

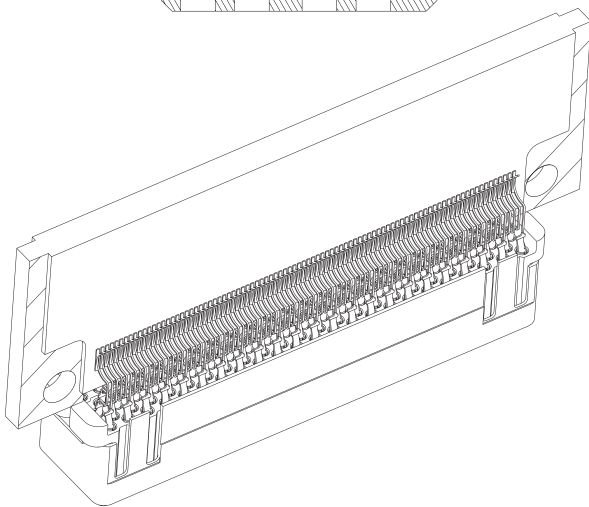
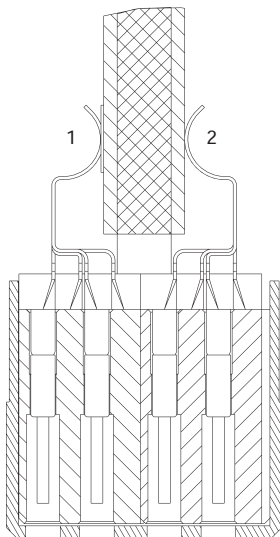
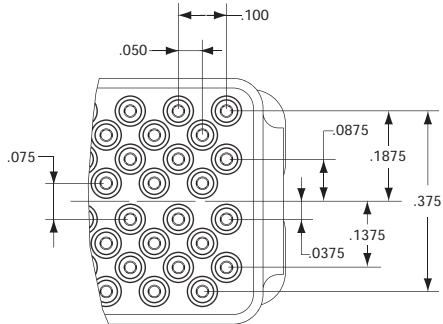

Staggered Grid Airflow-Thru

Staggered Grid Air-flow for Wider Board Packages

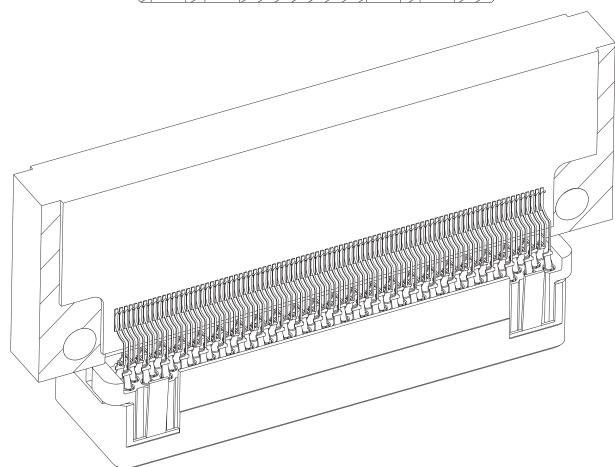
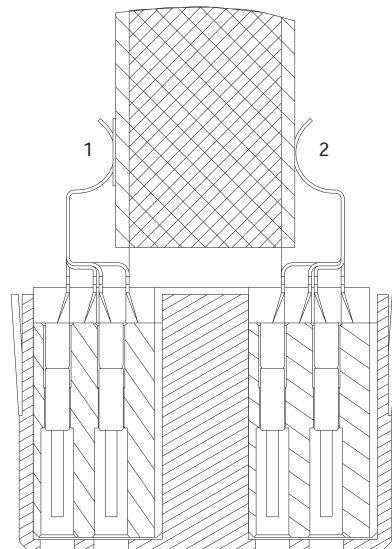
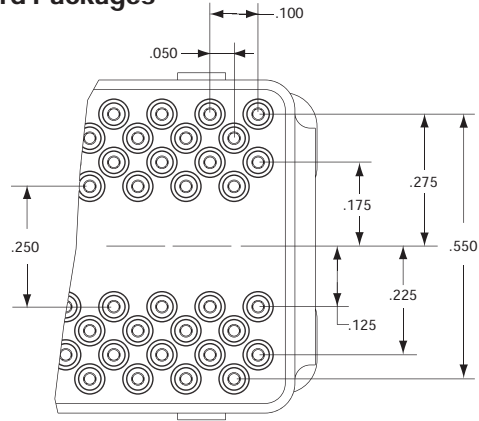

Introduction/
Pig-Solutions/
Brush Contact

LRM (Line Replaceable Modules)
Staggered / GEN-X
Fiber Optics / HiSpeed / RF/Power
Other Options (Access / VME/VITA(VIPER)

High Density
HD33
Hi Speed
HSB3

Low Mating Force MIL-DTL-55302
Standard / Hybrid - Signal/Power / Coax/Fiber Optics
Brush
Docking Conn./ Accessories/Install.

Rack & Panel
Brush
Ruggedized

LMD/LMS
Rectangular
Interconnects

Other
Rectangular
Interconnects

TYPICAL ARRANGEMENTS

Introduction/
Pkg. Solutions/
Brush Contact

LRM (Line Replaceable Modules)
Staggered/
GEN-X

Other Options/Access./
Fiber Optics/
Hi Speed/RF/Power

VME/VITA(VIPER)

High Density
HSB3 | HDB3
Hi Speed

Low Mating Force MIL-DTL-55302
Docking Conn./ Hybrids - Signal/Power/
Accessories/Install. | Standard
Coax/Fiber Optics | Brush

Rack & Panel
Brush
Ruggedized

LMD/LMS
Rectangular
Interconnects

Other
Rectangular
Interconnects

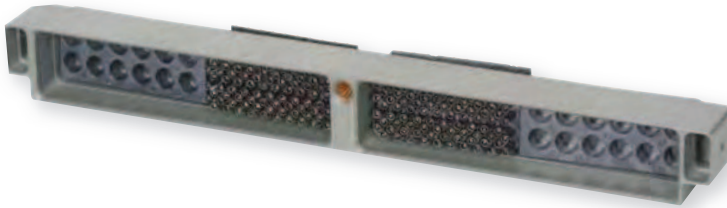

Example of a backplane connector in a 2 bay arrangement with inserts of staggered brush contacts and coax (size 12) contacts.

Staggered Grid LRM interconnects can be one, two or three bay configurations, and special additional bay arrangements. The typical arrangements shown here are depicted in one bay drawings. Amphenol's design flexibility also allow for combinations of contact types. These arrangements represent the versatility that can be arrived at by arranging digital (brush) inserts with inserts for power, RF, fiber optic and high speed contacts in various combinations within a typical bay. Consult Amphenol Aerospace for assistance in designing the LRM that best meets your specific application needs. See page 44 for an aid in selection and ordering.

80 brush contacts

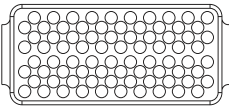

108 brush contacts

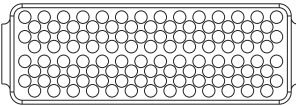

152 brush contacts

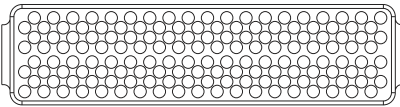

180 brush contacts

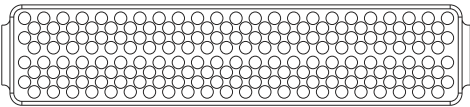

108 brush contacts plus 6 sz. 12 power or coax contacts

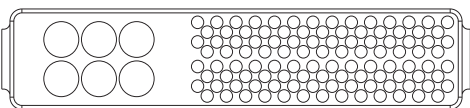

108 brush contacts plus 8 coax contacts

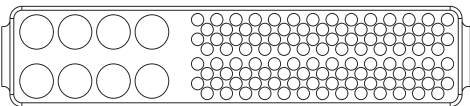

80 brush contacts plus 10 coax contacts

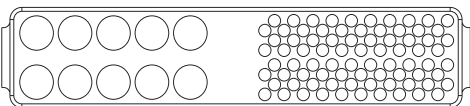

80 brush contacts plus 12 sz. 12 power or coax contacts

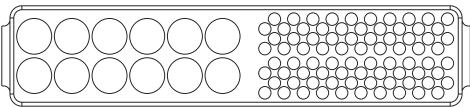

152 brush contacts plus 2 sz. 12 power or coax contacts

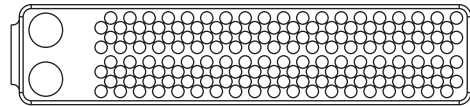

152 brush contacts plus 4 sz. 16 power or coax contacts

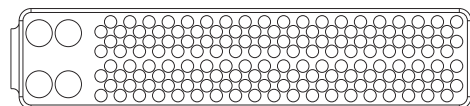

152 brush contacts plus 2 sz. 12 power or coax contacts

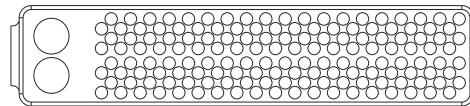

108 brush contacts plus 270 VDC power input

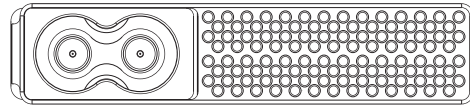

80 brush contacts plus 270 VDC power input

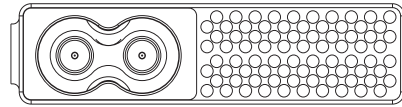

22 sz. 12 power contacts

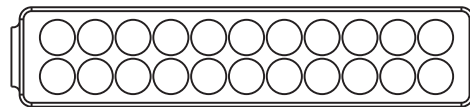

TYPICAL ARRANGEMENTS

144 brush contacts plus 4 fiber optic termini

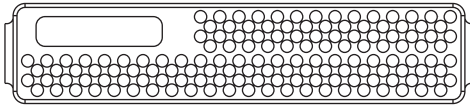

108 brush contacts plus 4 coax contacts and 4 fiber optic termini

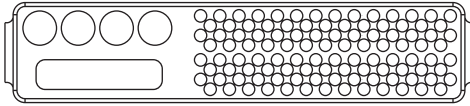

80 brush contacts plus 6 coax contacts

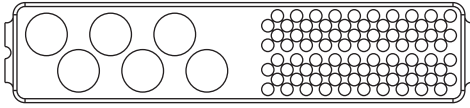

108 brush contacts plus an insert for 2 fiber optic MT ferrules*

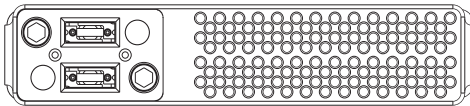

6 cavities for fiber optic MT ferrules*

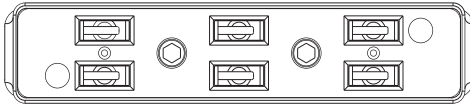

8 brush LVDS differential pairs plus an insert for 2 fiber optic MT ferrules*

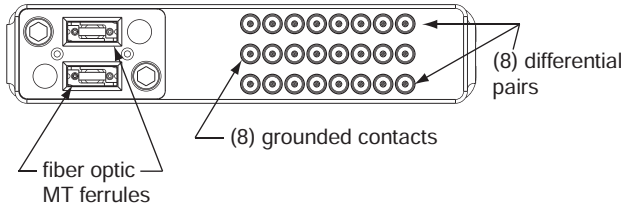

16 LVD pairs

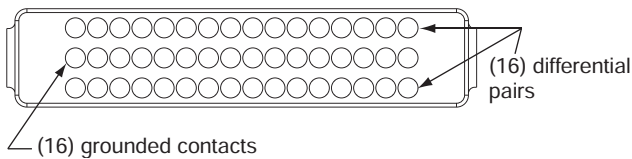

* MT ferrules are not supplied by Amphenol Aerospace. see page 27 for more information on LRMs with MT ferrules.

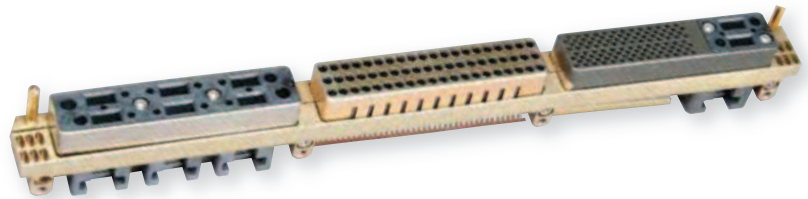

Example of a 3 bay module connector with an insert for MT fiber optic ferrules and inserts for brush LVDs and digital contacts.



Example of a 2 bay staggered grid module connector.

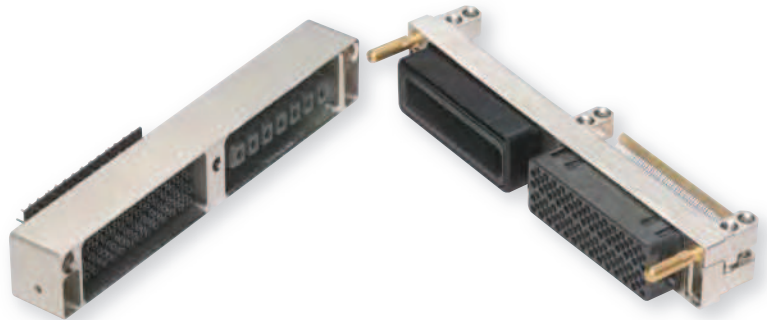

Example of a staggered grid module and backplane with 108 brush contacts and an insert for 7 size 20 crimp contacts for high voltage applications.

Introduction/
Pig. Solutions/
Brush Contact

Staggered/
GEN-X
Fiber Optics/
HiSpeed/RF/Power
Other Options/Access/
VME/VITA(VIPER)

High Density
HD33
HSB3
Hi Speed

Low Mating Force MIL-DTL-55302
Standard
Brush
Hybrid - Signal/Power/
Coax/Fiber Optics
Docking Conn./
Accessories/Install.

Rack & Panel
Brush
Ruggedized

LMD/LMS
Rectangular
Interconnects

Other
Rectangular
Interconnects

ARRANGEMENTS, CUSTOM SHELLS

Introduction/
Pkg. Solutions/
Brush Contact

The typical Airflow-thru arrangements are with brush contacts. The arrangements shown at left for staggered grid Airflow-thru are typical of what has been developed for customer requirements.

80 brush contacts
(airflow-thru)

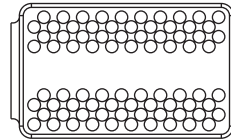

108 brush contacts
(airflow-thru)

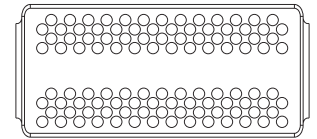

152 brush contacts (airflow-thru)

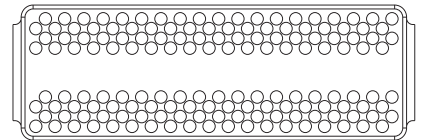

180 brush contacts (airflow-thru)

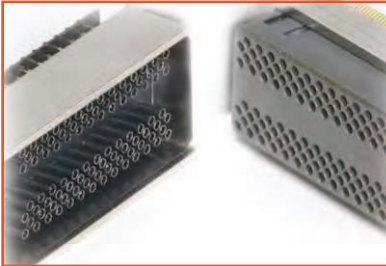
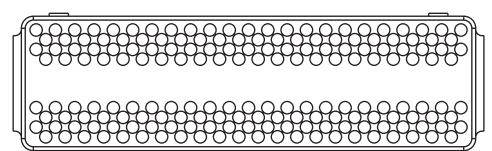

Staggered Grid Airflow-thru pattern - in a module on right, and in a backplane on left. Note the increased spacing in the center. This is designed for wider board packages, and accommodates airflow-thru heatsinks. (See illustration on page 17).

LRMs with airflow-thru inserts can be custom designed in combination with power contacts, such as the example below.

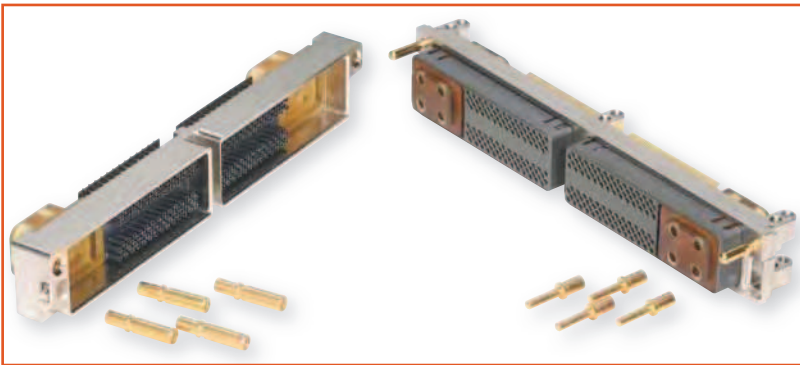

Module and backplane connectors with staggered airflow-thru inserts. Shown are 216 brush contacts and inserts for size 12 RADSOK® crimp contacts.

LRM (Line Replaceable Modules)
Staggered/
GEN-X
Fiber Optics/
Hi Speed/RF/Power

High Density
HDB3
HSB3
Hi Speed

Low Mating Force MIL-DTL-55302
Standard
Brush
Coax/Fiber Optics
Hybrids - Signal/Power/
Docking Conn./
Accessories/Install.

Rack & Panel
Brush
Ruggedized

LMD/LMS
Rectangular
Interconnects

Other
Rectangular
Interconnects

Amphenol designs and builds custom shell configurations such as the module face plate and its mating backplane connector.

This custom Airflow-thru module contains RADSOK® high amperage socket contacts in sizes 8 and 12.

See more description of RADSOK® contacts on page 122.

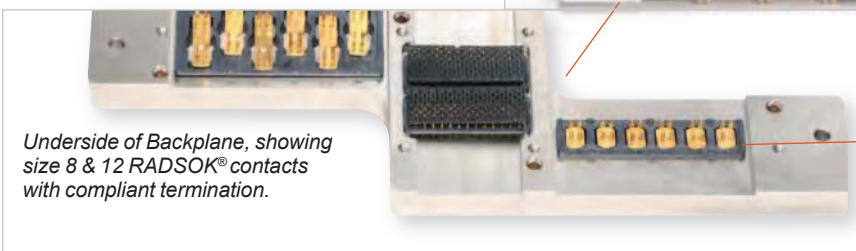
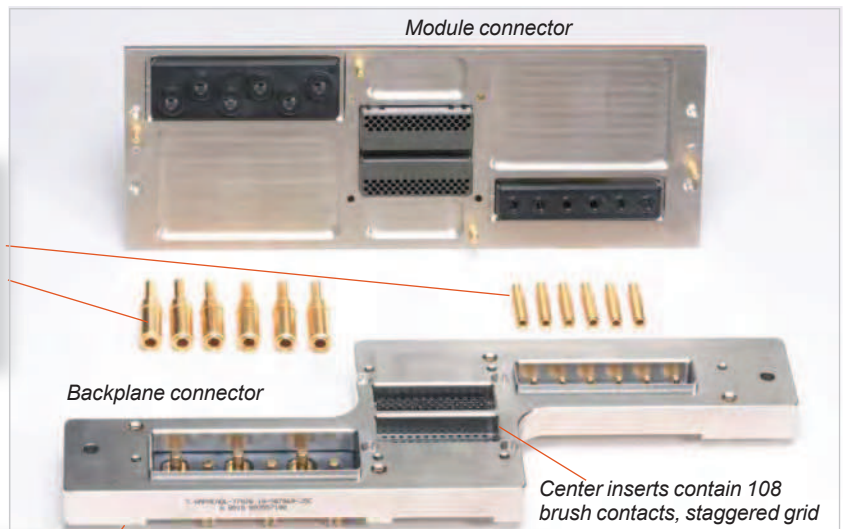

Underside of Backplane, showing size 8 & 12 RADSOK® contacts with compliant termination.



Closeup of insert with compliant pin termination power contacts.

TERMINATION OPTIONS

The following is a guide to the part number suffixes to be used when ordering LRM Connectors. Due to the complexity and number of variations within the part numbering, it is necessary to consult Amphenol Aerospace for assistance when building these part numbers. See page XX for an aid in selection and ordering, and call Amphenol at 607-563-5011 for technical support.

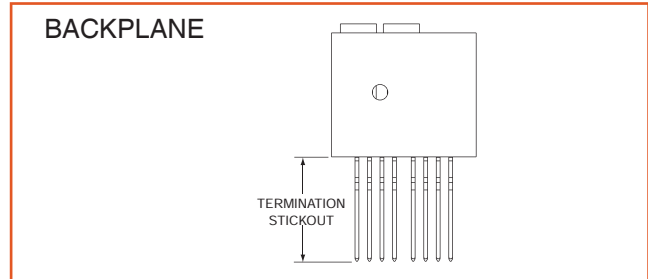
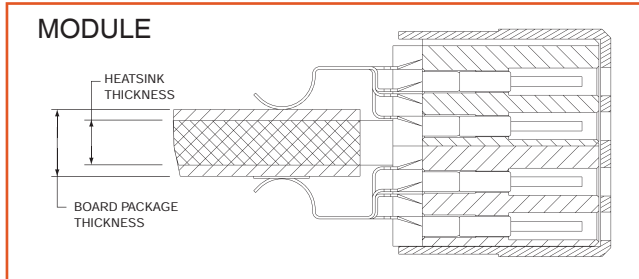

An example of a typical Amphenol Module part number is: **10-507XXX-X() ()**

10-507Designates Amphenol LRM Connectors

XXX-X.....Module Insert Arrangement Number - To be assigned by Amphenol.

()Heatsink Thickness Suffix for Modules

Suffix	Description
1	.125 ±.005
2	.100 ±.005
3	.075 ±.005
4	.062 ±.005

()Board Package Thickness Suffix for Modules

Suffix	Description Standard Staggered	Description Airflow-thru Staggered*
1	Surface Mount / .090 – .130 Package	Surface Mount / .265 – .305 Package
2	Surface Mount / .130 – .190 Package	Surface Mount / .305 – .365 Package
3	Surface Mount / .190 – .250 Package	Surface Mount / .365 – .425 Package
4	Surface Mount / .060 – .100 Package	Surface Mount / .235 – .275 Package
5	Surface Mount / .100 – .160 Package	Surface Mount / .275 – .335 Package
6	Surface Mount / .160 – .220 Package	Surface Mount / .335 – .395 Package

*.175 is added for increased center spacing in the airflow-thru staggered style

An example of a typical Amphenol Backplane part number is: **10-507XXX-X() ()**

10-507Designates Amphenol LRM Connectors

XXX-X.....Backplane Insert Arrangement Number - To be assigned by Amphenol.

()Termination Style Suffix for Backplanes

Suffix	Description
1	.021 ±.002 Dia. PCB Tail
2	.016 ±.002 Dia. PCB Tail
5	Compliant

()Termination Stickout Suffix for Backplanes

Suffix	Description
1	.150 ±.020 (PCB)
2	.200 ±.020 (PCB)
3	.250 ±.020 (PCB)
4	.300 ±.020 (PCB)
5	.350 ±.020 (PCB)
6	.400 ±.020 (PCB)
7	.185 ±.020 (PCB)
8	.450 ±.020 (PCB)
9	.500 ±.020 (PCB)
C	.157 ±.020 (Compliant, No Wrap)
D	.217 ±.020 (Compliant, 1 Wrap)
E	.317 ±.020 (Compliant, 2 Wrap)
F	.417 ±.020 (Compliant, 3 Wrap)

Introduction/
Brush Contact

Staggered /
GEN-X
Fiber Optics/
HiSpeed /RF/Power
Other Options /Access/
VME/VITA(VIPER)

High Density
HD33
HSB3
Hi Speed

Low Mating Force MIL-DTL-55302
Standard /Hybrids - Signal/Power/
Brush
Coax/Fiber Optics
Docking Conn./
Accessories/Install.

Rack & Panel
Brush
Ruggedized

LMD/LMS
Redangular
Interconnects

Other
Rectangular
Interconnects

TYPICAL PERFORMANCE, MATERIALS LIST

Table 1 below identifies the typical electrical, mechanical and environmental performance of an Amphenol 2 bay LRM connector assembly with 360 brush contacts in staggered grid. This data was program specific and does not reflect actual performance limitations. Table II below provides a materials list for the components of staggered grid LRM connectors.

TABLE I: PERFORMANCE

ELECTRICAL PERFORMANCE	
Electrical Parameters	Performance
Current carrying capability	10°C temperature rise at 2A and 30°C rise at 3A
Contact resistance	30 milliohms max. per contact, 25 milliohms max. average
Dielectric withstanding voltage at sea level	100 VRMS, 60 Hz
Dielectric withstanding voltage at altitude	100 VRMS, 60 Hz at 70,000 ft.
Insulation Resistance	1000 megohm minimum at 100V d.c.
Electrostatic Discharge Protection (module only)	± 25,000 minimum air and direct discharge (see pg. XX for details)

MECHANICAL PERFORMANCE	
Mechanical Parameters	Performance
Contact retention (solder type backplane assembly)	Maximum displacement of 0.010" at 1 pound load
Mating and unmating forces	Maximum 40.0 pounds mating and unmating
Vibration (Sinusoidal, 20g peak max.)	No electrical discontinuity >1 μS
Vibration (Random, 11.6g RMS max.)	No electrical discontinuity >1 μS
Shock (50g max. shock pulse)	No electrical discontinuity >1 μS
Solderability	Minimum 95% solder coverage
Resistance to soldering heat	260°C dip for 10 seconds

ENVIRONMENTAL PERFORMANCE	
Environmental Parameters	Performance
Temperature life	250 hours at 125°C maximum
Connector durability	500 cycles mating and unmating
Salt fog exposure	48 hours maximum direct exposure (5% NaCl)
Thermal shock	500 cycles at +125°C / -65°C
Humidity exposure	240 hours at 90 - 98%
Contamination exposure	Sand and dust per MIL-STD-202 Method 110
Resistance to solvents	Boiling Trichloroethylene fumes and solution

TABLE II: MATERIALS LIST

ENVIRONMENTAL PERFORMANCE	
Part	Material / Finish Description
Brush wires	Beryllium copper per ASTM B197; finish is gold per ASTM B488 over nickel per AMS-QQ-N-290. (The exposed ends of the brush wires need not be plated).
Module contacts	Beryllium copper per ASTM B534 C17500, or C17510 except temper HTC; finish on contact body is matte tin-lead per ASTM B579; finish on termination end is 60/40 or 63/37 tin-lead dip per J-STD-004, -005 and -006.
Backplane contacts (Compliant termination)	Contact barrel: brass per ASTM B4531/B453M-01 similar to UNS C33500; finish is tin-lead per SAE-AMS-P-81728 (min. 15% ±5% lead) over nickel. Contact tail: beryllium copper per ASTM B-534 alloy 17510 HT; finish is gold per ASTM B-488 over nickel per AMS-QQ-N-290. Contact sleeve: stainless steel per AMS 5514; finish is black oxide per MIL-DTL-13924 and conformally coated per MIL-I-46058.
Backplane contacts (PCB termination)	<u>Contact body</u> : brass similar to UNS C33500; finish is gold over nickel; termination end is 60/40 or 63/37 tin lead dip. <u>Contact sleeve</u> : stainless steel per AMS 5514; finish is black oxide per MIL-DTL-13924 and conformally coated per MIL-I-46058.
Insulators	Polyphenylene Sulfide or Liquid Crystal Polymer per MIL-M-24519
Organizer	Polyphenylene Sulfide or Liquid Crystal Polymer per MIL-M-24519
Shells	Aluminum alloy 6061-T6 per AMS 4150; finish is electroless nickel per SAE AMS 2404.
ESD shields	Aluminum alloy 6061-T6 per AMS 4150; finish is hardcoat anodize per MIL-A-8625 with epoxy final coat. Ground tabs are chromate treated (irridite).
Polarization keys	Stainless steel per AMS 5640; finish is black oxide per MIL-DTL-13924. Key retaining ring is Polyamide (nylon 12) with 50% glass filled fibers.
Guide pins	Beryllium copper alloy per ASTM B196, finish is gold per ASTM B 488 over nickel per AMS-QQ-N-290.

GEN-X PROVIDES HIGHER CONTACT DENSITY

Staggered Grid Contact Density

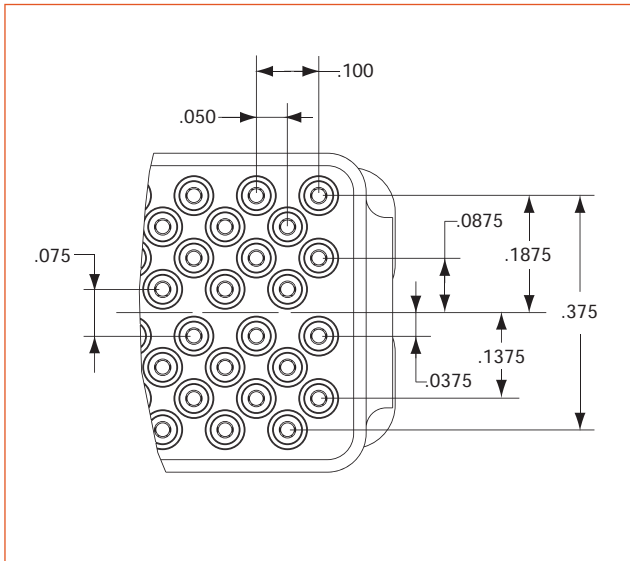

GEN-X Contact Density

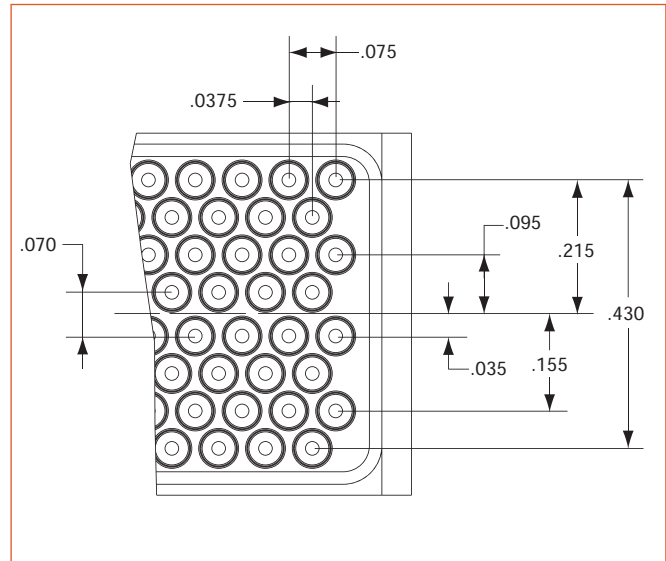

Staggered Grid Module Termination

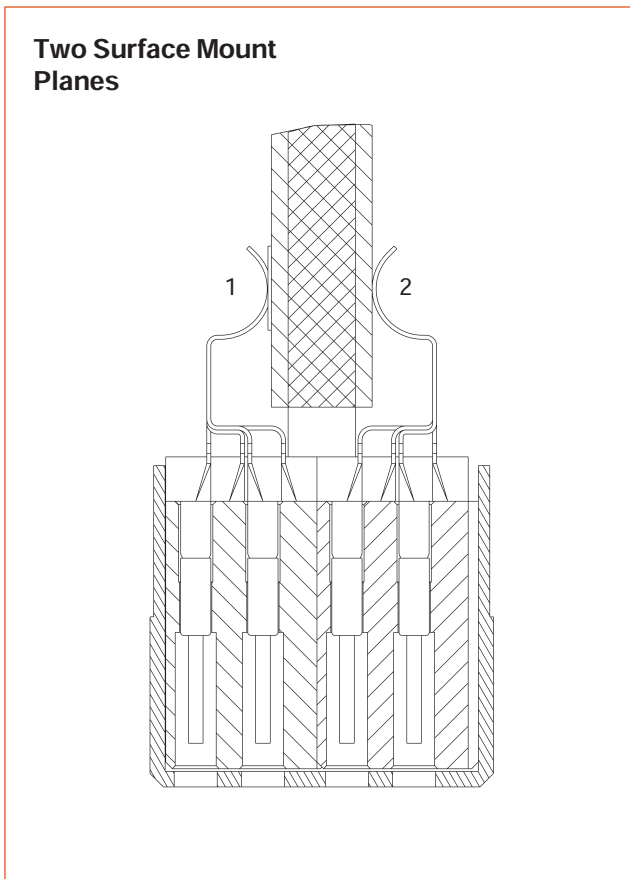

GEN-X Module Termination

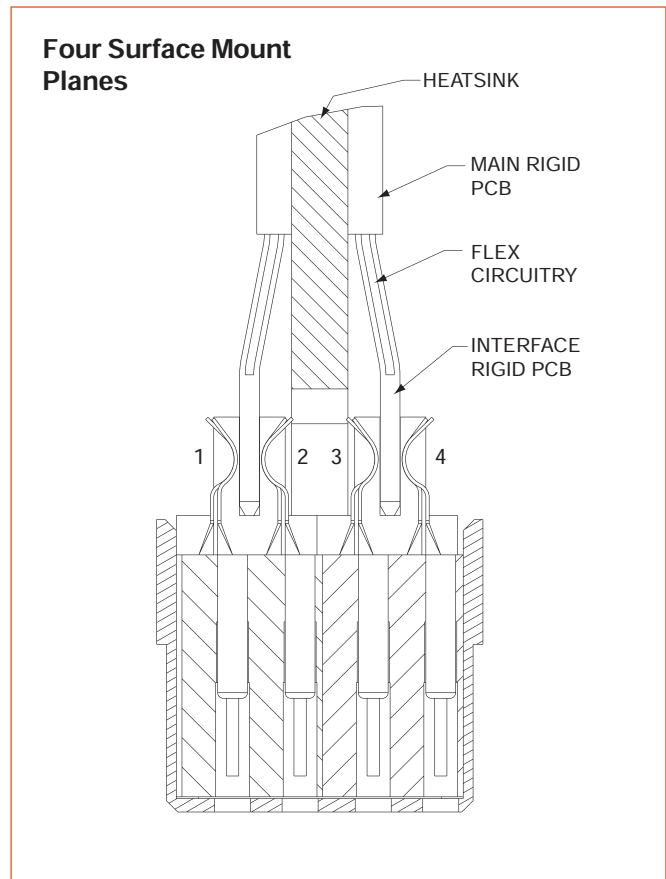

Introduction/
Pig. Solutions/
Brush Contact

LRM (Line Replaceable Modules)
Staggered/
GEN-X
Fiber Optics/
HiSpeed/RF/Power
Other Options: Access/
VME/VITA(VIPER)

High Density
HD33
Hi Speed
HSB3

Low Mating Force MIL-DTL-55302
Standard
Brush
Hybrids - Signal/Power/
Coax/Fiber Optics
Docking Conn./
Accessories/Install.

Rack & Panel
Brush
Ruggedized

LMD/LMS
Rectangular
Interconnects

Other
Rectangular
Interconnects

GEN-X PROVIDES HIGHER CONTACT DENSITY

Staggered Grid Tail to Tail Placement

Staggered Grid LRM has 0.025 tail to tail centerline spacing

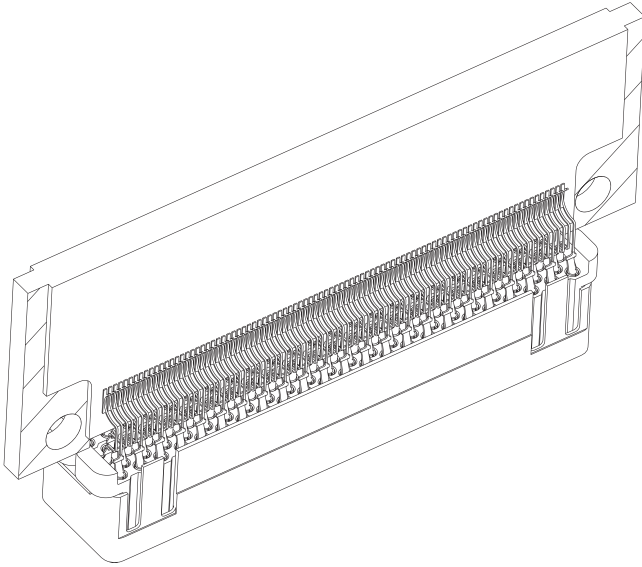

GEN-X Tail to Tail Placement

GEN-X Grid LRM has 0.0375 tail to tail centerline spacing

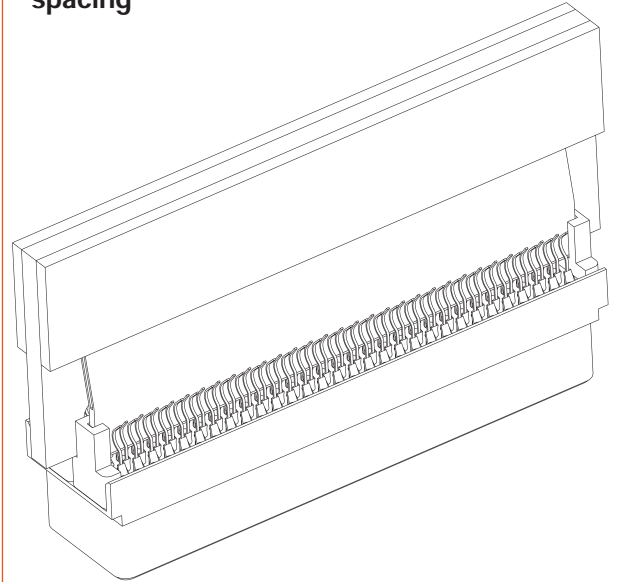

GEN-X is Designed to Terminate to Rigid-Flex PCB Attachment

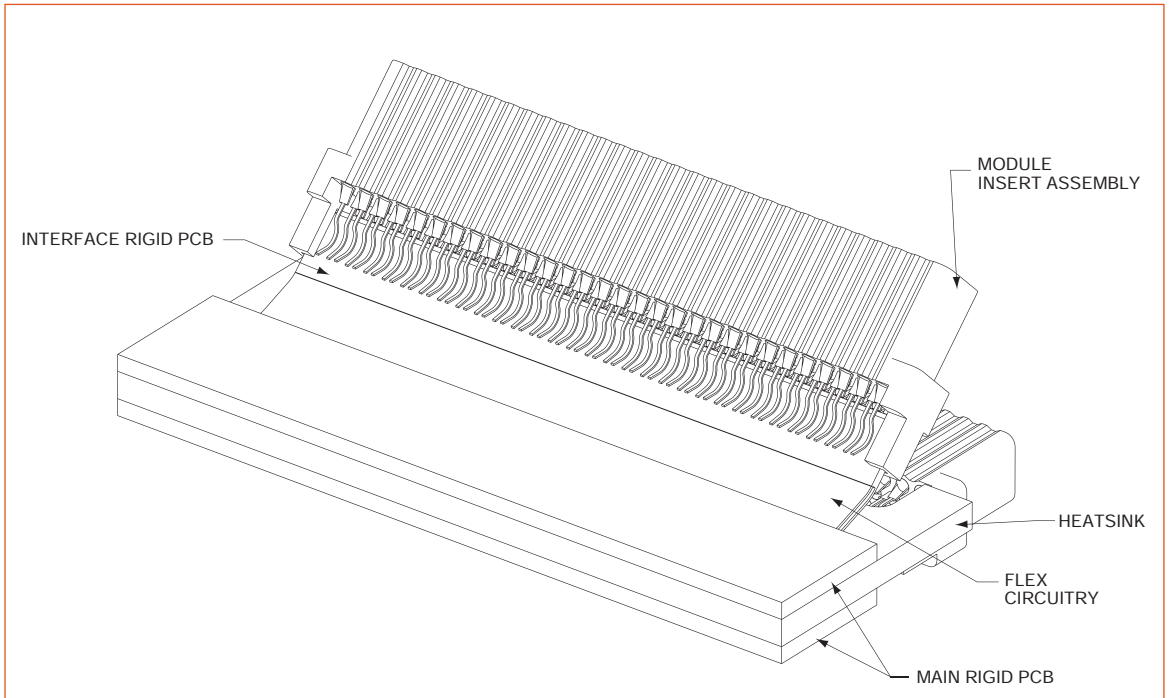

Introduction/
Pkg. Solutions/
Brush Contact

LRM (Line Replaceable Modules)
Other Options/Access./
VME/VITA(VIPER)
Fiber Optics/
Hi Speed/RF/Power
Staggered/
GEN-X

High Density
HSB3
Hi Speed
HDB3

Low Mating Force MIL-DTL-55302
Docking Conn./
Accessories/Install.
Hybrids - Signal/Power/
Coax/Fiber Optics
Standard
Brush

Rack & Panel
Brush
Ruggedized

LMD/LMS
Rectangular
Interconnects

Other
Rectangular
Interconnects

CONTACT PATTERN & ARRANGEMENTS

The LRM GEN-X pattern employs surface mount leads on a .0375 inch center line (module connector), yet provides higher contact density than the Staggered grid pattern. GEN-X provides all the same features as the staggered grid LRM:

- GEN-X digital (brush) inserts are available in 118 and 236 pin contact counts.
- Digital contacts can also be combined with inserts for fiber optics, RF, poser and high speed contacts.
- Various combinations of inserts can be provided in 1, 2 or 3 bay shell configurations.
- Typical insert arrangements shown here are depicted in one bay drawing.

Consult Amphenol Aerospace for assistance in designing the LRM that best meets your specific application needs. See page 44 for an aid in selection and ordering of LRM and LRU interconnects.

118 brush contacts

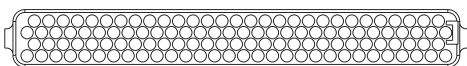

236 brush contacts

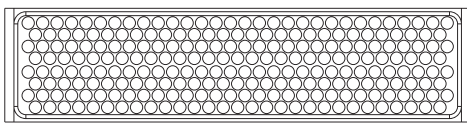

140 brush contacts plus an insert for 2 fiber optic MT ferrules*

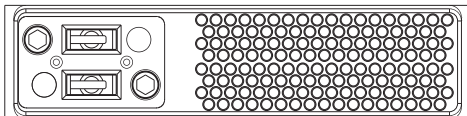

212 brush contacts plus 2 sz. 16 power or coax contacts

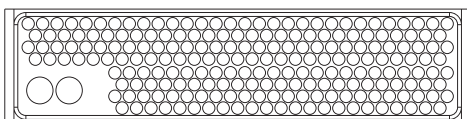

* MT ferrules are not supplied by Amphenol Aerospace. see page 27 for more information on LRMs with MT ferrules.



Example of a 3 bay GEN-X backplane connector.

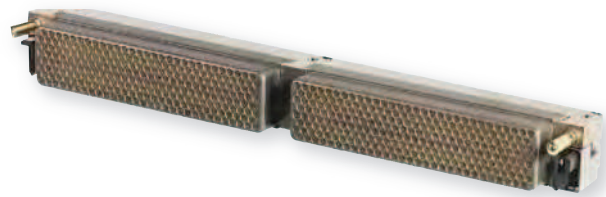
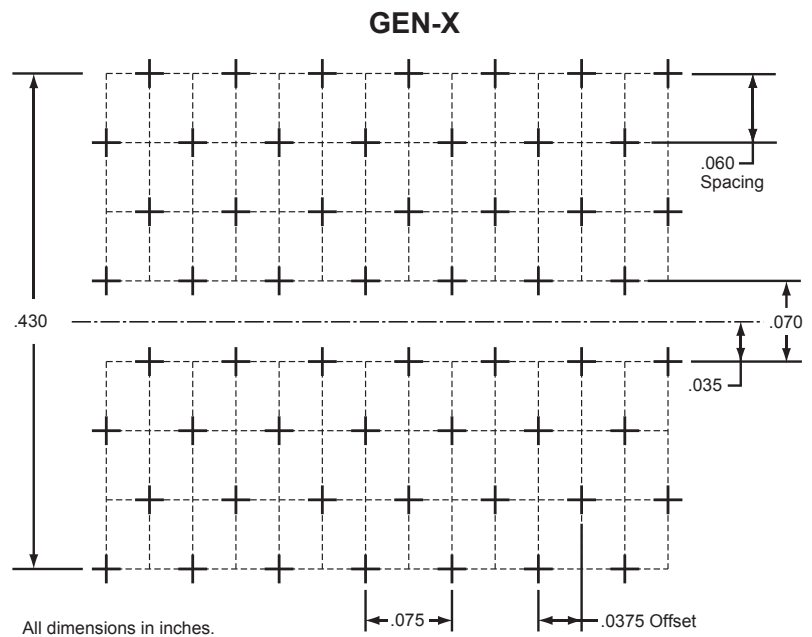

Example of a 2 bay GEN-X module connector.

170 brush contacts plus 6 sz. 16 power or coax contacts

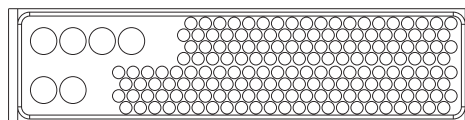

170 brush contacts plus 4 fiber optic termini and 2 sz. 16 contacts

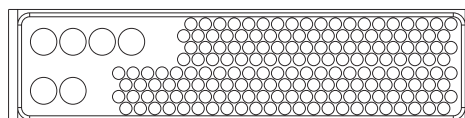

Introduction/
Pig. Solutions/
Brush Contact

Staggered/
GEN-X

Fiber Optics/
HiSpeed/RF/Power

Other Options/Access/
VME/VITA(VIPER)

High Density
HD33
HSB3
Hi Speed

Low Mating Force MIL-DTL-55302
Standard
Brush

Hybrid - Signal/Power/
Coax/Fiber Optics

Docking Conn./
Accessories/Install.

Rack & Panel
Brush
Ruggedized

LMD/LMS
Rectangular
Interconnects

Other
Rectangular
Interconnects

LRMS WITH FIBER OPTIC TERMINI

Introduction/
Pkg. Solutions/
Brush Contact

High speed fiber optic transmission is available within LRM connectors for use in advanced avionics systems. Optical performance of fiber optic termini within in LRM connectors are the same as termini used in circular connectors.*

Insertion losses range from .3dB to <1.5dB depending upon launch conditions, fiber NA, fiber size and the type of termination.

Inserts for MIL-T-29504/1, /2, /14 and /15 can be incorporated. Termini for LRMs can be supplied by Amphenol; consult for ordering information. The termini are determined by insert and shell style of the connector.

LRM interconnects can have hybrid arrangements of fiber optics with Brush contacts, as well as other contact types.

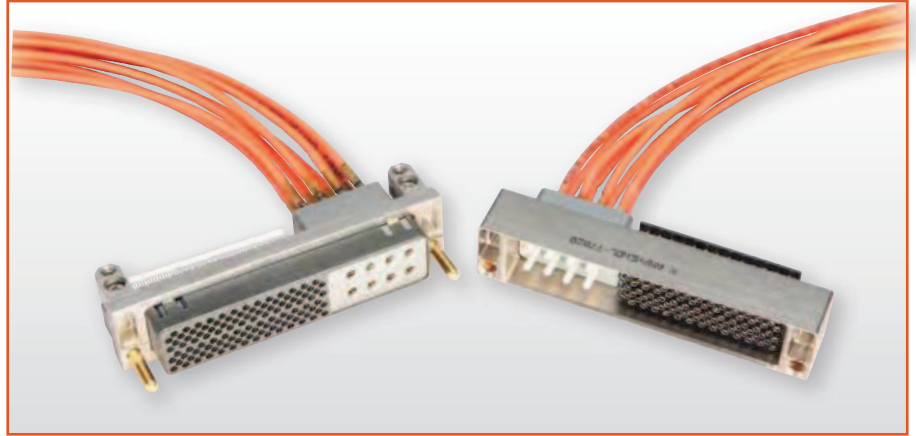

LRM (Line Replaceable Modules)
Other Options/Access./
VME/VITA(VIPER)

High Density
HSB3
Hi Speed

Staggered Grid Patterns with MIL-T-29504 Fiber Optic Termini

(These drawings are also shown with other staggered grid patterns on pages 18 & 19).

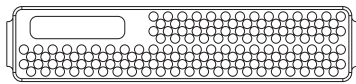

144 brush contacts plus an insert for 4 fiber optic termini

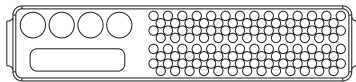

108 brush contacts plus an insert for 4 shielded contacts and an insert for 4 fiber optic termini

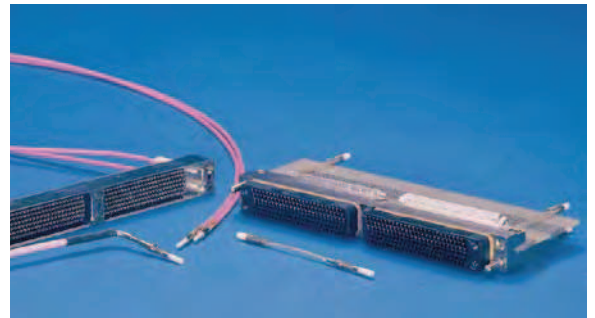

Examples of LRM connectors with fiber optic multi-mode termini in combination with brush contacts.

Low Mating Force MIL-DTL-55302
Docking Conn./
Accessories/Install.

GEN-X Patterns with MIL-T-29504 Fiber Optic Termini

(This drawing is also shown with other GEN-X patterns on page 25).

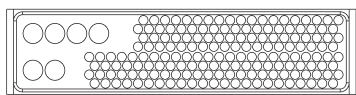

170 brush contacts plus an insert for 4 fiber optic termini plus 2 sz. 16 contacts

Rack & Panel
Brush
Ruggedized

LMD/LMS
Rectangular
Interconnects

Other
Rectangular
Interconnects

*For more information on Amphenol fiber optic circular connectors, see Amphenol Circular Interconnects Catalog 12-C3, Fiber Optic section

LRMS WITH INSERTS FOR MT FERRULE FIBER OPTICS

Through Amphenol's LRM design flexibility, inserts are available to house high speed MT ferrules which can have 12 fiber lines per ferrule or 24 fiber lines per ferrule. MT ferrules are not supplied by Amphenol; they must be purchased separately.

Termini for rectangular LRM connectors are determined by insert and shell style of the connector.

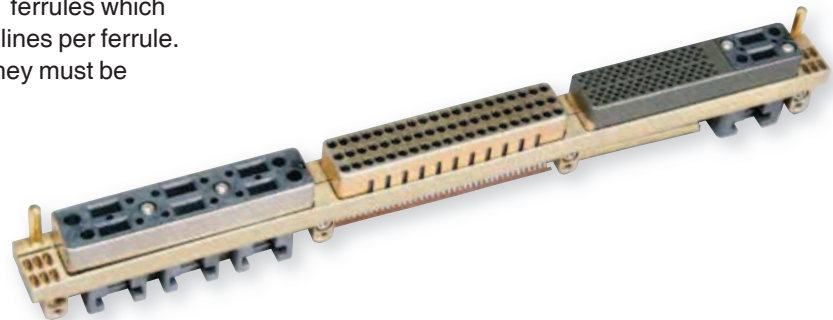

Example of an LRM module connector with MT fiber optic inserts in combination with inserts for brush LVDs and digital contacts.

Staggered Grid Patterns with MT Ferrule Fiber Optics

(These drawings are also shown with other staggered grid patterns on pages 18 & 19).

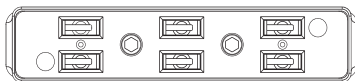

Insert with cavities for 6 fiber optic MT ferrules



Insert with 8 brush differential pairs plus an insert for 2 fiber optic MT ferrules

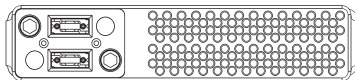

Insert for 108 brush contacts plus an insert for 2 fiber optic MT ferrules

GEN-X Patterns with MT Ferrule Fiber Optics

(These drawings are also shown with other GEN-X patterns on page 25).

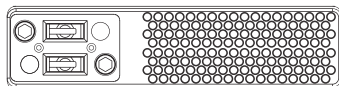

140 brush contacts plus an insert for 2 fiber optic MT ferrules

Amphenol can supply optical backplane assemblies; see more information in the Other Board Level and Rectangular Interconnects Section on page 115.

LRM Module Insert Assembly with MT Termini

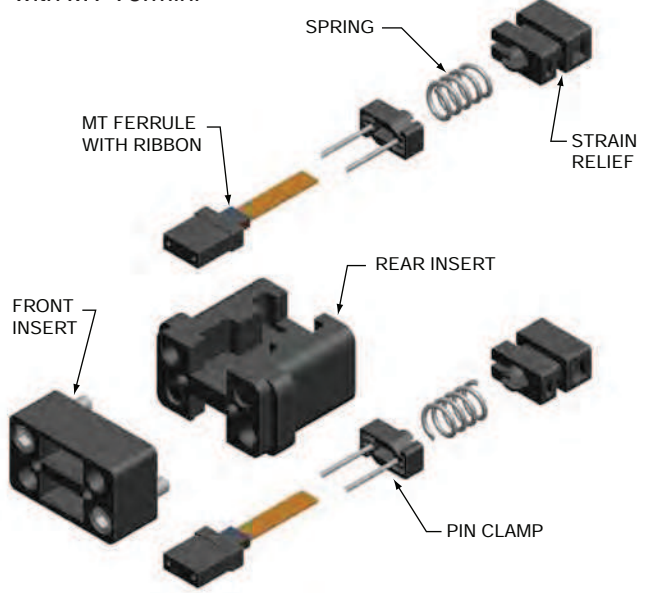

LRM Backplane Insert Assembly with MT Termini

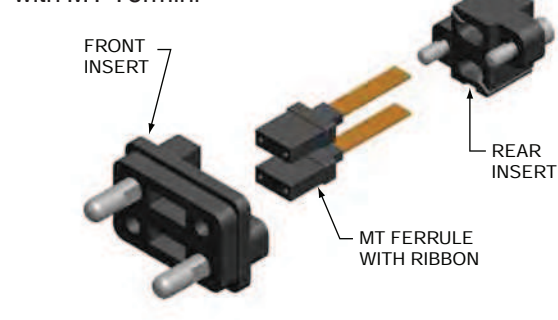

Introduction/
Pkg. Solutions/
Brush Contact

Staggered/
GEN-X

Fiber Optics/
HiSpeed/RF/Power

Other Options/Access/
VME/VITA(VIPER)

High Density
HD3
HSB3
Hi Speed

Low Mating Force MIL-DTL-55302
Standard
Brush
Hybrid - Signal/Power/
Coax/Fiber Optics

Docking Conn./
Accessories/Install.

Rack & Panel
Brush
Ruggedized

LMD/LMS
Rectangular
Interconnects

Other
Rectangular
Interconnects

Introduction/
Pkg. Solutions/
Brush Contact

LRM (Line Replaceable Modules)
Staggered/
GEN-X

Fiber Optics/
Hi Speed/RF/Power

Other Options/Access./
VME/VITA(VIPER)

High Density
HSB3 | HDB3
Hi Speed

Low Mating Force MIL-DTL-55302
Standard
Brush

Hybrids - Signal/Power/
Coax/Fiber Optics

Docking Conn./
Accessories/Install.

Rack & Panel
Brush
Ruggedized

LMD/LMS
Rectangular
Interconnects

Other
Rectangular
Interconnects

LRM inserts have been designed to accommodate the following RF and high speed coaxial contacts:

- Size 16 M39029/79 & /80 shielded contacts
- Size 12 coax for DC-65 GHz
- Size 8 coax for DC-32 GHz
- SMPM RF contacts*
- Hybrid arrangements with RF or high speed shielded contacts and brush contact combinations

Staggered Grid Patterns with RF/Coaxial Contacts

(These drawings are also shown with other staggered grid patterns on pages 18 & 19).

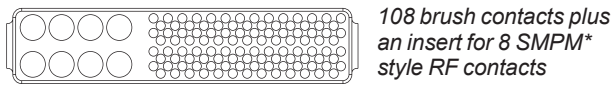

108 brush contacts plus an insert for 8 SMPM* style RF contacts

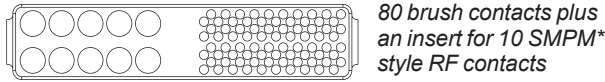

80 brush contacts plus an insert for 10 SMPM* style RF contacts

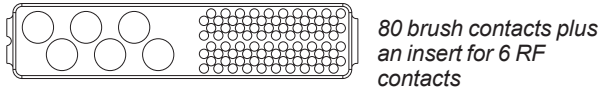

80 brush contacts plus an insert for 6 RF contacts

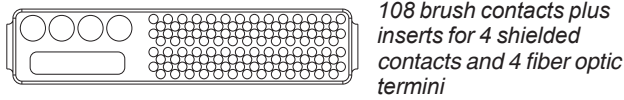

108 brush contacts plus inserts for 4 shielded contacts and 4 fiber optic termini

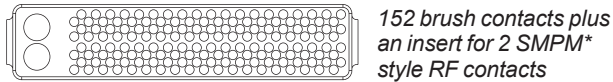

152 brush contacts plus an insert for 2 SMPM* style RF contacts

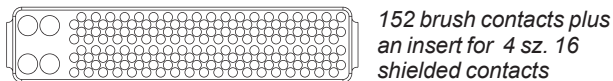

152 brush contacts plus an insert for 4 sz. 16 shielded contacts

* See more information on SMPM RF contacts in Other Rectangular Interconnects Section, page 124. SMPM RF contacts can be supplied by Amphenol SV Microwave. Phone: 561-840-1800 Website: www.svmicrowave.com

Amphenol has also developed inserts with brush differential pair contacts that are 100 ohm matched impedance. These support data rates with excess of 1.2 Gbps.

Staggered Grid Patterns with LVDS Differential Pairs

(These drawings are also shown with other staggered grid patterns on page 19).

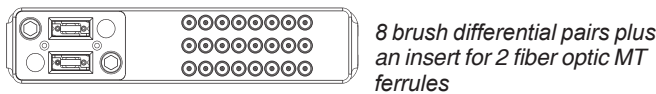

8 brush differential pairs plus an insert for 2 fiber optic MT ferrules

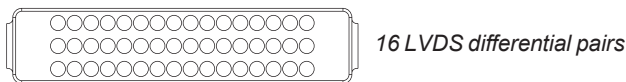

16 LVDS differential pairs



RF module and backplane with size 8 coaxial contacts



Staggered grid module with cavities for size 12 coaxial contacts

GEN-X Patterns with RF/Coaxial Contacts

(These drawings are also shown with other GEN-X patterns on page 25).

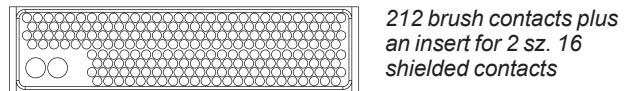

212 brush contacts plus an insert for 2 sz. 16 shielded contacts

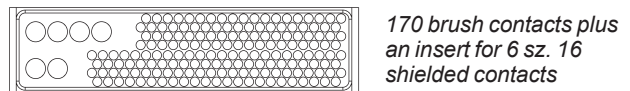

170 brush contacts plus an insert for 6 sz. 16 shielded contacts

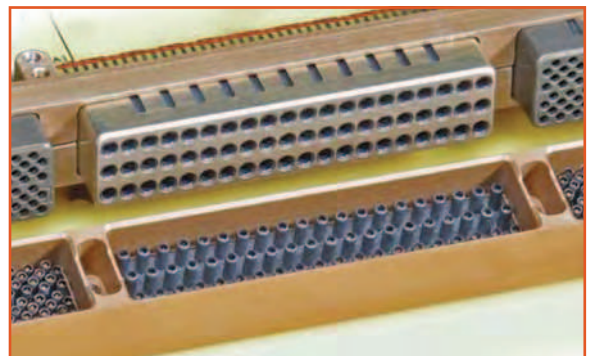

Module and backplane with LVDS differential pair brush contacts

POWER SUPPLY MODULES, LRMS WITH RADSOK®

Power Supply Modules

Amphenol has designed several custom 270VDC sections which are capable of providing corona-free operation at 75,000 ft. They utilize size 22D contacts and are available in both crimp and compliant pin terminations.

Amphenol has developed the patterns shown below that incorporate 270 VDC power modules.

(These drawings are also shown with other staggered grid patterns on page 18).

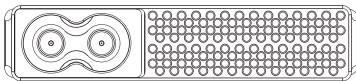

108 brush contacts plus 270 VDC power input

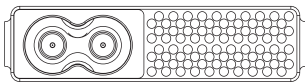

80 brush contacts plus 270 VDC power input



Power supply modules

LRM Connectors with RADSOK® Contacts

New/Featured Product

High Amperage RADSOK® socket contacts have been designed into LRM connectors in response to customer needs for passing of larger amounts of current with lower mating forces which standard contacts will not handle.

The connector design shown at right has 8 groups of 3 bussed RADSOK 3.6mm sockets (24 contacts total). Each group of 3 is expected to handle a maximum of 140A. Mating pins for the RADSOK® sockets are press-fit into aluminum bus bars behind the motherboard connector.



The RADSOK® socket cylinder within female contact has several equally spaced longitudinal beams twisted into a hyperbolic shape. As the male pin is inserted, axial members in the female half deflect, imparting high current flow across the connection with minimal voltage loss. The hyperbolic, stamped grid configuration ensures a large, coaxial, face-to-face surface area engagement.



LRM inserts with RADSOK® high amperage contacts

See more interconnects that incorporate RADSOK® contacts in the Other Board Level and Rectangular Interconnects Section, pages 122 & 123. Also, for more information on Amphenol RADSOK® connectors, see the Amphenol Industrial Operations catalog SL-391 on-line at www.amphenol-industrial.com.

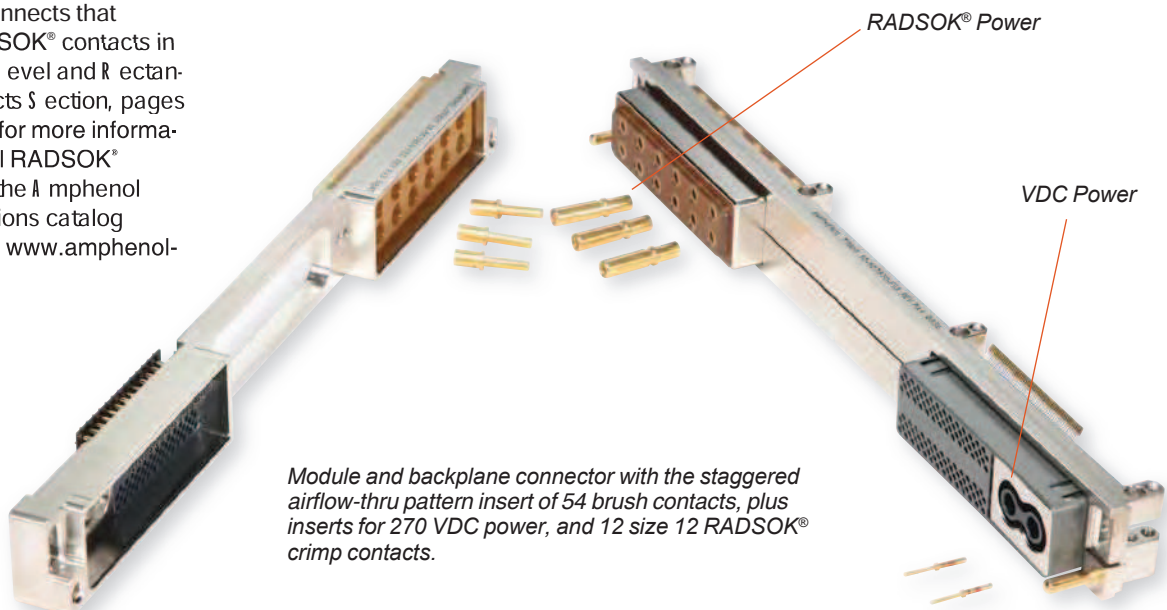

Module and backplane connector with the staggered airflow-thru pattern insert of 54 brush contacts, plus inserts for 270 VDC power, and 12 size 12 RADSOK® crimp contacts.

Introduction/
Pig-Solutions/
Brush Contact

Staggered/
GEN-X

Fiber Optics/
HiSpeed/R/P/Power

Other Options/Access/
VME/VITA(VIPER)

High Density
HD33
HSB3
Hi-Speed

Low Mating Force MIL-DTL-55302
Standard
Brush
Hybrids - Signal/Power/
Coax/Fiber Optics

Docking Conn./
Accessories/Install.

Rack & Panel
Brush
Ruggedized

LMD/LMS
Redundant/
Interconnects

Other
Rectangular
Interconnects

New/Featured Product

Amphenol's LRM connectors meet today's need for high speed interconnects for harsh environments. Constantly evolving and striving to meet the needs of higher data transfer rates within a board level product, Amphenol has developed LRM's to meet this challenge. These LRMs are designed, or can be configured, to achieve data rates up to 6.25 Gb/s and include all the features of our rugged and reliable staggered grid LRM series:

- Brush contact interface
- ESD protection (Level 2 flight line classification)
- Connector float
- Guide pins and polarization keys
- Metal shells
- Modular design (hybrid configuration available)
- Accepts wide range of board packages
- Accommodations for custom modular offsets

In addition, the new GigaStak™, GigaStak-LG™ and DigiStak™ Series incorporate Amphenol's cStack™ solderless termination technology (see page 34 for details).

Versatility

Unique flex and cStack terminations accommodate a variety of mounting configurations and a wide range of board packages. Connectors can terminate in a variety of ways:

- "traditional" 2 board/heatsink package
- to one or both sides of a single board
- as an offset board package

DigiStak module connectors allow mating to existing configurations of backplane connectors (users can upgrade solder termination module connectors to the solderless cStack termination).

The Hi-Speed Family of LRM Connectors and associated data rates includes:

- Gigastak™ - 6.25 Gb/s
- Gigastak LG™ - 3.125 Gb/s
- Digistak™ & Digistak-X™ - 3.125 Gb/s
- Standard Staggered Grid - 1.25 Gb/s



GigaStak™ Hi-Speed Inserts (left & right: 60 Brush differential pairs; middle: 18 Brush differential pairs plus 180 Brush low speed signal contacts)



Hybrid Connector that has GigaStak-LG™ and DigiStak™ Inserts, shown on Testing Boards

Example of a Hi-Speed Hybrid Connector

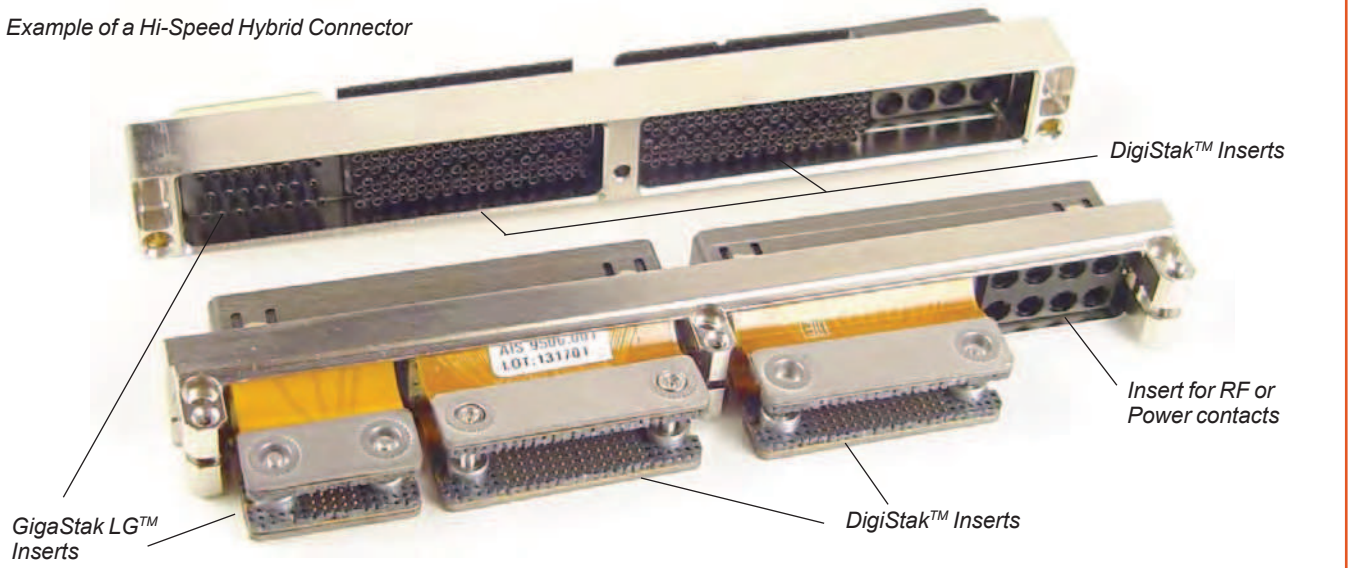

Introduction/
Pkg. Solutions/
Brush Contact

LRM (Line Replaceable Modules)
Other Options/Access./
VME/VITA(VIPER)
Fiber Optics/
Hi Speed/RF/Power
Staggered/
GEN-X

High Density
HSB3
Hi Speed
HDB3

Low Mating Force MIL-DTL-55302
Docking Conn./
Accessories/Install.
Hybrids - Signal/Power/
Coax/Fiber Optics
Standard
Brush

Rack & Panel
Brush
Ruggedized

LMD/LMS
Rectangular
Interconnects

Other
Rectangular
Interconnects

GIGASTAK™- THE HIGHEST DENSITY HI-SPEED CONNECTOR

New/Featured Product

Amphenol has taken the proven and highly reliable LRM Brush connector and incorporated the cStack™ termination technology - giving the user hi-speed signal options up to 6.25 Gb/s and a solderless termination to their CCA.

Through strategic placement of signal and ground contacts, each insert arrangement is optimized for the perfect balance of impedance control and cross-talk mitigation for a given data rate.

GigaStak Features:

- Hi-Speed connector designed for both single ended and differential signals
- Supports data rates of 6.25 Gb/s
- High density providing 30 differential signals per linear inch
- Designed for 100 ohm differential impedance
- Optimized cross-talk

GigaStak Patterns

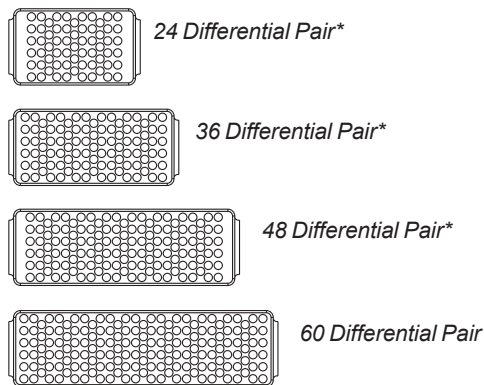

* Consult Amphenol for availability.

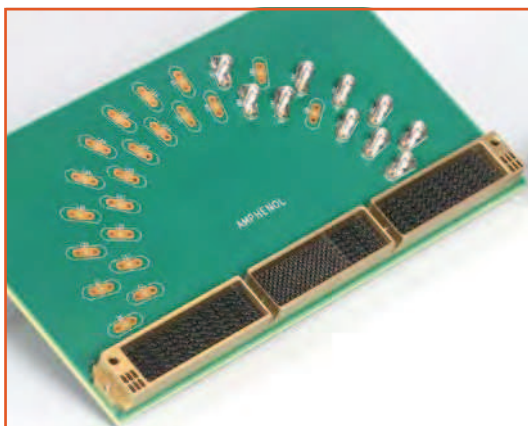

Validation testing has been performed through both simulation (CST Microwave Studio) and actual testing of production connectors. Test reports, touchstone files and hardware are available for review.



GigaStak™ Backplane Connector

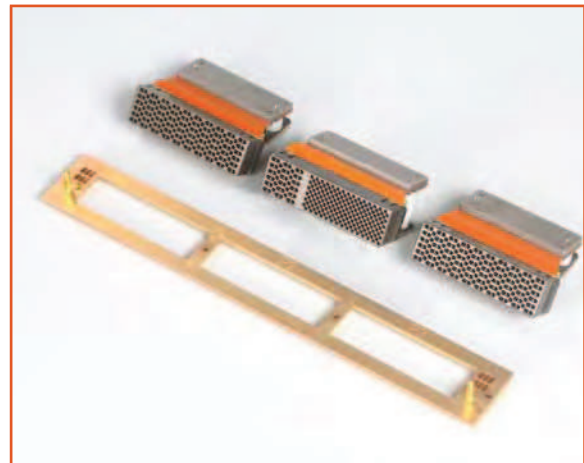

GigaStak™ Module Unassembled

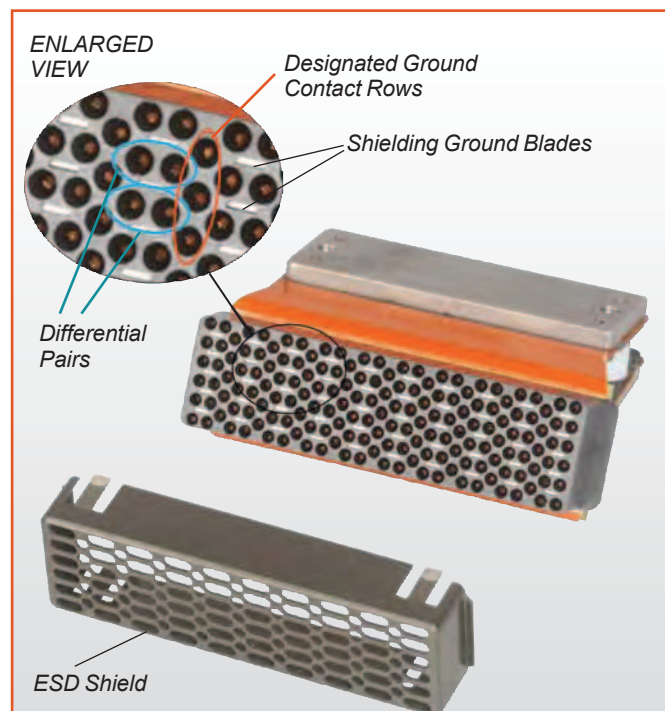

GigaStak 60 Differential Pair Insert with ESD Shield Exploded and Enlarged Section

Introduction/
Pig. Solutions/
Brush Contact

Suggested/
GEN-X

Fiber Optics/
HiSpeed/Rf/Power

Other Options/Access/
VME/VITA(VIPER)

High Density
HD33
HSB3
Hi-Speed

Standard
Brush

Hybrid - Signal/Power/
Coax/Fiber Optics

Docking Conn./
Accessories/Install.

Rack & Panel
Brush
Ruggedized

LMD/LMS
Rectangular
Interconnects

Other
Rectangular
Interconnects

LRM (Line Replaceable Modules)

GIGASTAK-LG™

New/Featured Product

The GigaStak-LG™ inserts provide hi-speed data transferance, utilizes cStack solderless termination, and can be combined with low speed signal contacts, as shown in the hybrid connector photo below.

GigaStak LG Features:

- Hi-Speed connector designed for differential signals
- Supports data rates of 3.125 Gb/s
- Current Design has 8 differential pairs
- Provides 11 differential signals per linear inch
- Designed for 100 ohm differential impedance
- Optimized cross-talk

GigaStak LG Patterns

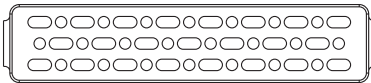

23 Differential Pairs

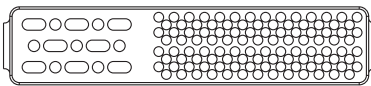

8 Differential Pairs and 108 Digital Contacts

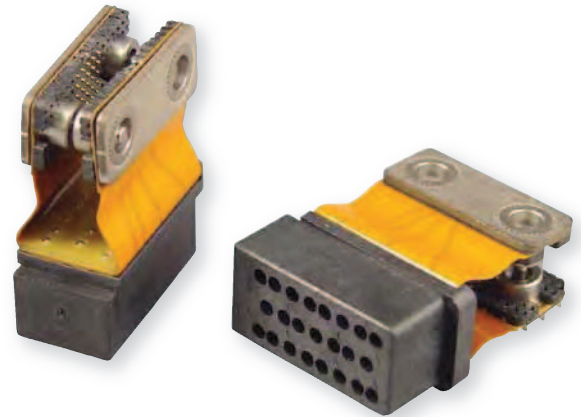

GigaStak-LG™ Inserts with 8 Hi-Speed Differential Pairs



GigaStak-LG Inserts with 8 Hi-Speed Differential Pairs Packaged with Staggered Grid Inserts with Low Speed Signal Contacts

Combined GigaStak-LG and DigiStak Insert (see next page for DigiStak description)

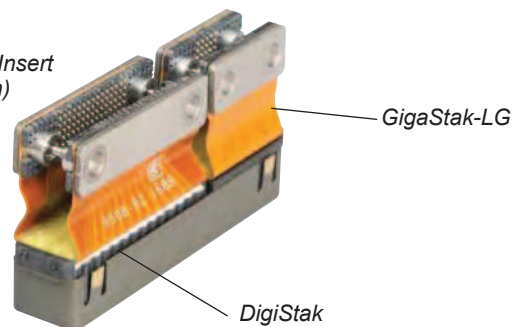

GigaStak-LG

DigiStak

Introduction/
Pkg. Solutions/
Brush Contact

Staggered/
GEN-X

Fiber Optics/
Hi Speed/RF/Power

Other Options/Access./
VME/VITA(VIPER)

LRM (Line Replaceable Modules)

High Density
HSB3
HDB3
Hi Speed

Low Mating Force MIL-DTL-55302
Docking Conn./
Accessories/Install.

Hybrids - Signal/Power/
Coax/Fiber Optics

Standard
Brush

Rack & Panel
Brush
Ruggedized

LMD/LMS
Rectangular
Interconnects

Other
Rectangular
Interconnects

DIGISTAK™ AND DIGISTAK-X™

New/Featured Product

DigiStak™ Hi-Speed LRM Inserts

The DigiStak™ connector provides the standard staggered grid LRM pattern in a hi-speed connector that utilizes cStack solderless termination.

DigiStak Features:

- Designed to improve data rates in existing staggered grid LRM inserts
- Supports data rates of 3.125 Gb/s
- Configurable for up to 20 differential pairs per linear inch
- Designed for 100 ohm differential impedance
- Optimized cross-talk

The DigiStak uses standard staggered grid insert pattern shown at right. (Pages 18 and 19 show the arrangements of staggered grid connectors which are also available in the DigiStak connector).

DigiStak-X™ Hi-Speed LRM Inserts

The DigiStak-X™ connector provides the GEN-X grid LRM pattern in a hi-speed connector that utilizes cStack solderless termination.



DigiStak-X Features:

- Designed to improve data rates in existing GEN-X LRM inserts
- Supports data rates of 3.125 Gb/s
- Configurable for up to 20 differential pairs per linear inch
- Designed for 100 ohm differential impedance
- Optimized cross-talk

The DigiStak-X uses GEN-X LRM grid pattern shown at right (Page 25 shows the arrangements of GEN-X grid connectors which are also available in the DigiStak-X connector).

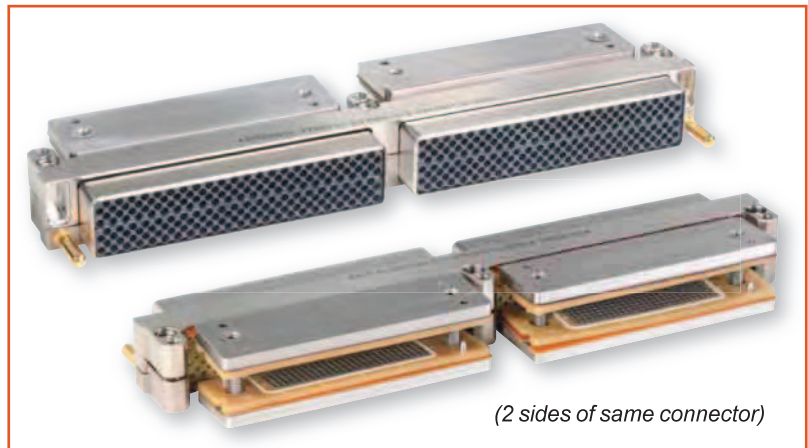

360 Pin DigiStak Module Connector

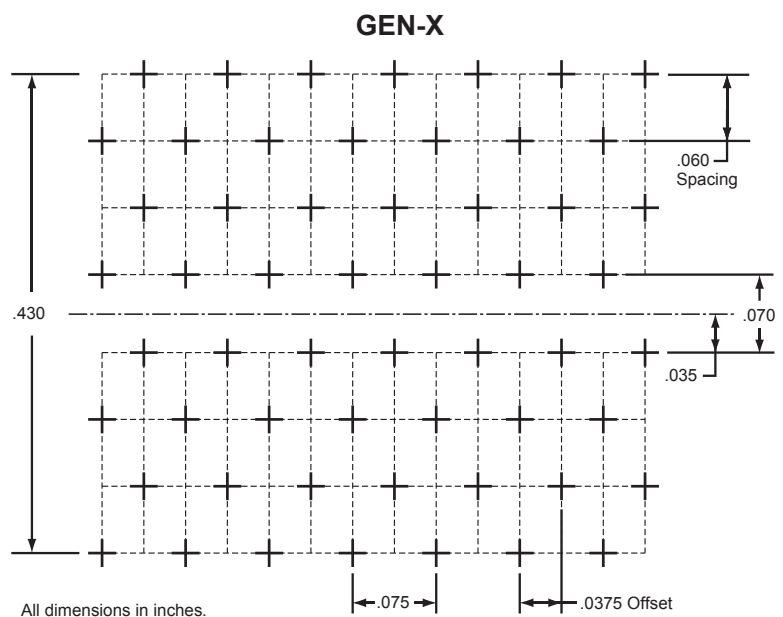
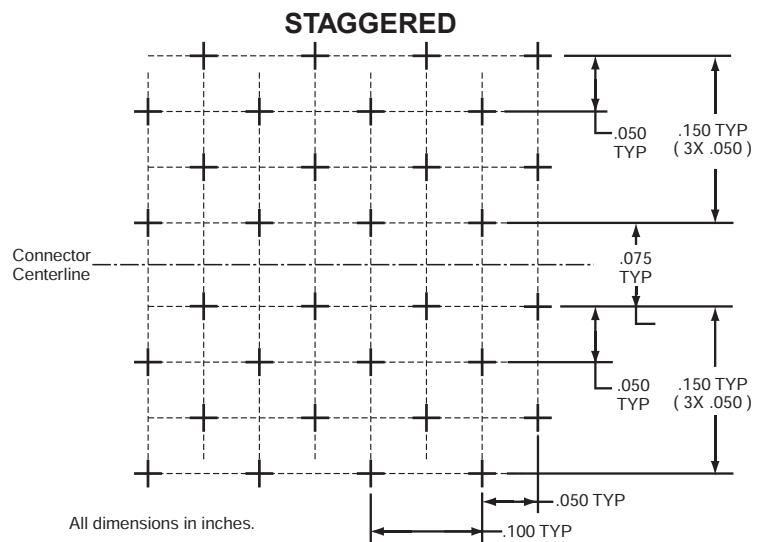

Introduction/ Pigs/Solutions/ Brush Contact	Staggered/ GEN-X	Fiber Optics/ HiSpeed/Rf/Power	Other Options/Access/ VME/VITA(VIPER)	High Density HD33 HSB3 Hi Speed	Low Mating Force MIL-DTL-55302 Standard Brush	Hybrid - Signal/Power/ Coax/Fiber Optics	Docking Conn./ Accessories/Install.	Rack & Panel Brush Ruggedized	LMD/LMS Redangular Interconnects	Other Redangular Interconnects
---	---------------------	-----------------------------------	--	--	---	---	--	-------------------------------------	--	--------------------------------------

CSTACK™ TECHNOLOGY

New/Featured Product

Anatomy of cStack™ Technology

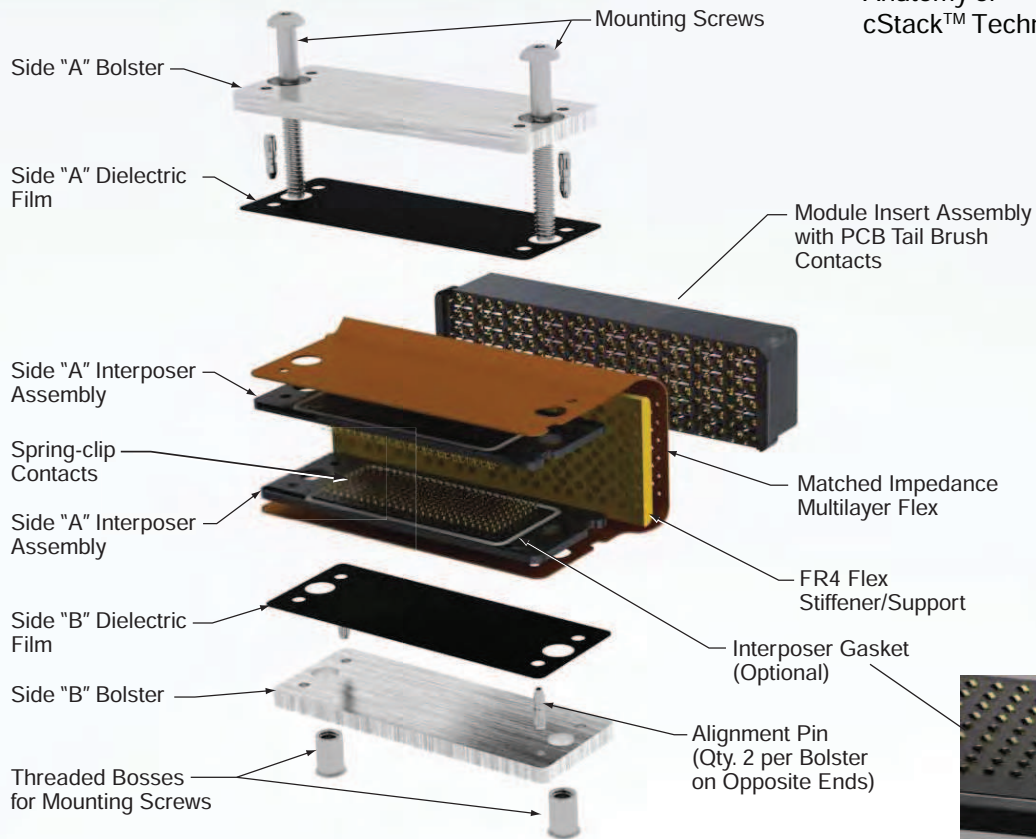

Enlarged view of cStack™ Contact

cStack™ Termination

GigaStak™, GigaStak-LG™, DigiStak™ and DigiStak-X™ series incorporate Amphenol's cStack™ termination which provides the following features and benefits:

- Flex circuit assemblies that provide high speed, impedance controlled performance with high signal integrity.
- Flex can be electrically and mechanically customized to fit system specifications.
- Allows solderless interconnection between flex and board, eliminating a principal reliability problem with traditional flex assemblies.
- Standard and customized hardware are available which allow fast, solderless interconnection with only screw attachment to boards. Hardware uses captive attachment screws, eliminating loose component pieces.

See more information on Flex Circuitry in the Other Rectangular Interconnects Section page 119 of this catalog.

cStack™ Technology for Hi-Speed LRM Connectors

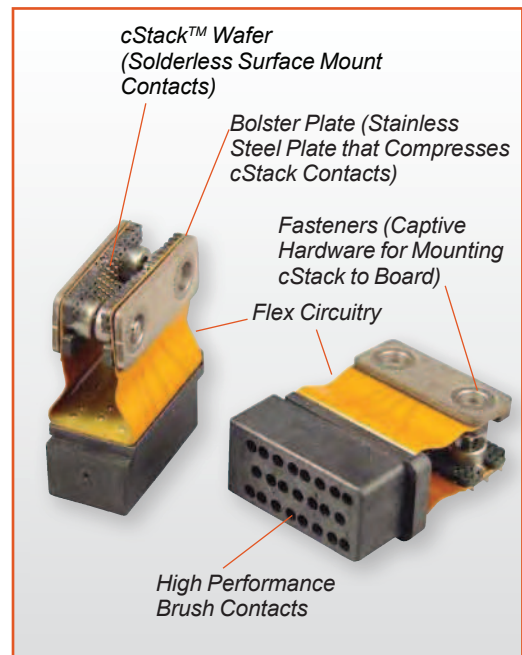

Introduction/
Pkg. Solutions/
Brush Contact

LRM (Line Replaceable Modules)
Other Options/Access./
VME/VITA(VIPER)
Fiber Optics/
Hi Speed/RF/Power
Staggered/
GEN-X

High Density
HDB3
HSB3
Hi Speed

Low Mating Force MIL-DTL-55302
Docking Conn./
Accessories/Install.
Hybrids - Signal/Power/
Coax/Fiber Optics
Standard
Brush

Rack & Panel
Brush
Ruggedized

LMD/LMS
Rectangular
Interconnects

Other
Rectangular
Interconnects

MODELING, SIMULATION, TESTING

Amphenol's Capabilities for Modeling and Testing Hi-Speed Contacts and Connectors

Signal Integrity

- Amphenol SI engineers apply their expertise at the system level and work hand-in-hand with design engineering

Modeling & Simulation

- Amphenol uses powerful modeling, simulation and analysis tools
- CST Microwave Studio
- Allows characterization of current designs
- Rapidly aids in development of new, high speed designs
- S-parameter and SPICE analysis

Test Capability

- System level (full thread) and "connector only"
- TDR with iConnect software
 - Capability for S-parameter to 15 GHz
 - Time domain/eye pattern to 10 Gb/s
- BERT to 6.5 Gb/s

Customer Support

- Amphenol SI engineers directly support customers on their specific applications providing S-parameter data and Touchstone files

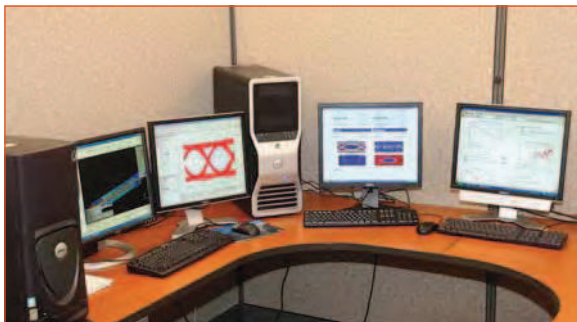

Hi-Speed Simulation Software used at Amphenol Aerospace.

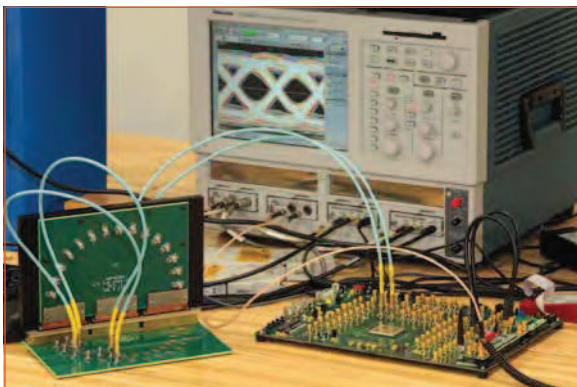

Test bench for LRM connectors. Computer screen shows a pass/fail mask test eye diagram.

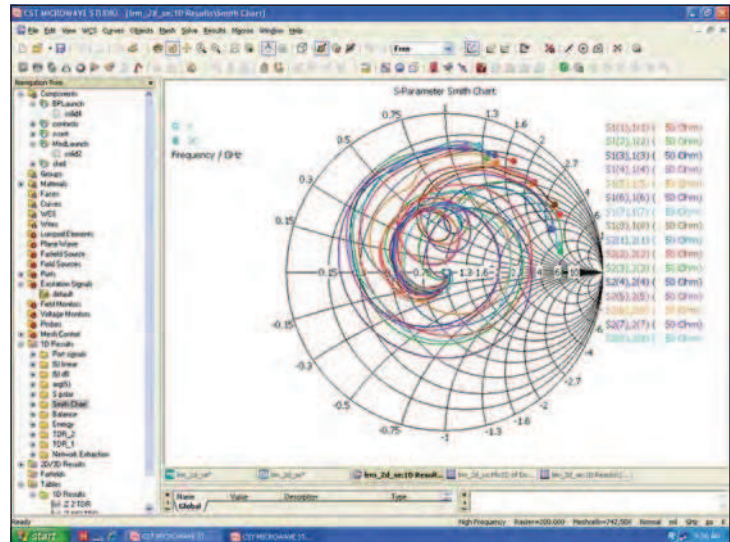

Smith Chart

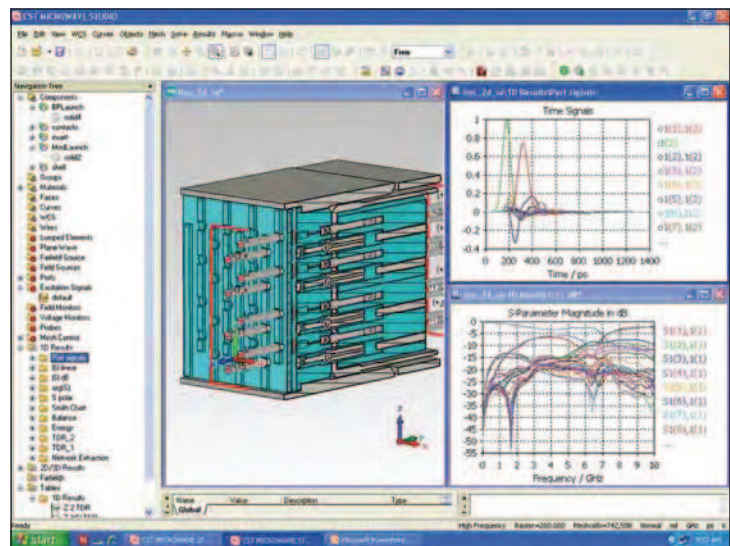

3DEM Model/S-Parameter

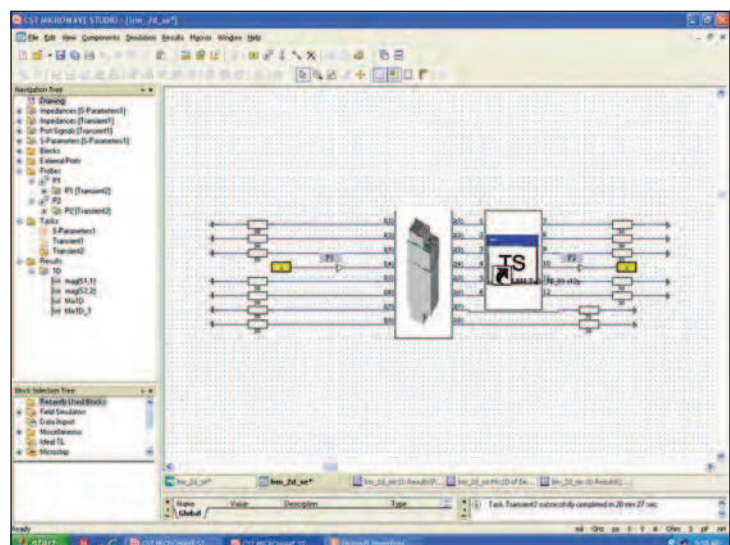

Circuit Simulation Schematic

Introduction/
Pig-T Solutions/
Brush Contact

Ruggedized/
GEN-X

LRM (Line Replaceable Modules)
Fiber Optics/
HiSpeed/RF/Power

Other Options/Access/
VME/VITA(VIPER)

High Density
HD33

HSB3
Hi-Speed

Low Mating Force MIL-DTL-55302
Standard

Hybrids - Signal/Power/
Coax/Fiber Optics

Docking Conn./
Accessories/Install.

Rack & Panel
Brush
Ruggedized

LMD/LMS
Redangular
Interconnects

Other
Rectangular
Interconnects

Introduction/
Pkg. Solutions/
Brush Contact

LRM (Line Replaceable Modules)
Other Options/Access./
VME/VITA(VIPER)
Fiber Optics/
Hi Speed/RF/Power
Staggered/
GEN-X

High Density
HSB3
Hi Speed
HDB3

Low Mating Force MIL-DTL-55302
Docking Conn./
Accessories/Install.
Hybrids - Signal/Power/
Coax/Fiber Optics
Standard
Brush

Rack & Panel
Brush
Ruggedized

LMD/LMS
Rectangular
Interconnects

Other
Rectangular
Interconnects

Flex Circuitry Used on LRM Connectors

Flex termination can be an integral part of the LRM connector insert as shown on top right photo or it can be used to attach the connector to the printed circuit board, as shown on next photo below.

When used for attachment to PC boards the flex circuitry is designed to meet specific length, current carrying capacity and to fit the precise geometric shape of the connector to board package. Amphenol APC (Amphenol Printed Circuits) designs and manufactures the flex circuitry. Sculptured® Flexible Circuits have built-in terminations which eliminate the failures associated with crimped or soldered-on contacts, as well as geometrically fitting the tight space requirements within a package. Flex material is strong and rigid, yet highly flexible. See page XX in the Other Rectangular Products section for more information on Flex circuitry.

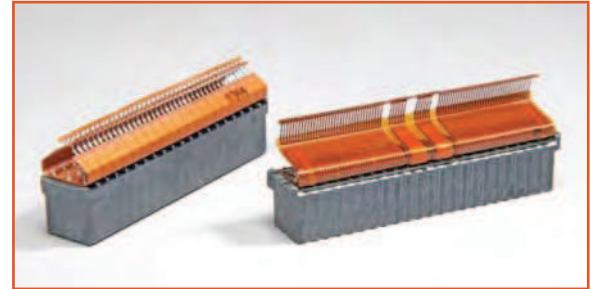

LRM module inserts with flex termination

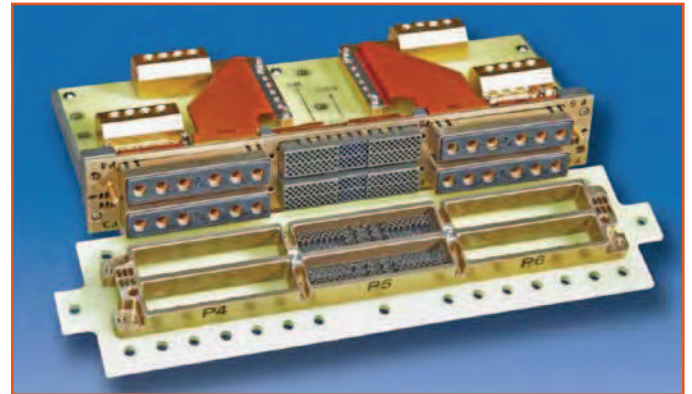

Flex circuitry used to attach to PC boards - designed to fit specific board requirements

Compliant Pins

Compliant pin contacts are available for LRM backplane connectors. These are a press fit type contact which provide reliable, reduced cost, solderless mounting to printed circuit boards. Connectors are sold completely assembled with compliant pins and they accommodate boards with minimum of 0.125 inch thickness and 0.025 ±.002 plated through holes.



LRM backplane insert with compliant pins



LRM backplane insert with compliant pins for power contact termination

PC Tail Contacts

LRM modules can be designed with PC tail contacts for solder mounting on printed circuit boards or flex circuits. These are called I/O (input-output) LRM modules and have staggered grid pattern.



LRM module inserts (showing front and back of inserts) with PC tails in staggered grid pattern

ELECTROSTATIC DISCHARGE (ESD) PROTECTION

Amphenol has developed cylindrical and rectangular connectors which protect sensitive components from Electrostatic Discharge (ESD) without diodes, varistors, gas tubes, or “experimental” semiconductive materials.

These connectors utilize the Faraday Cage principal to shunt electrostatic discharge events to the conductive enclosure on which the connector is mounted, thus never allowing the high voltage, high current discharge event to reside on any contacts.

The ESD protected connectors have the same physical envelope as their standard counterparts, and do not require special mounting or terminating techniques. All of the contacts remain fully functional, and electrical characteristics such as capacitance are not affected.

- LRM Connectors with ESD protection have the following features and benefits:
- Connector envelope is identical to unprotected design for most applications
- Exceeds protection requirements of IEC 801-2 and MIL-STD-1686:
 - Ensures that all components within a conductive enclosure are not subjected to more than 10V during electrostatic discharges between -26 KV and +26 KV
- Voltage observed on contacts during ESD events: <10V (at 1 megohm)
- Current observed on contacts during ESD events: < 100 milliamperes (at 2 ohms)
- Response time is instantaneous (voltage and current are maximum values)
- Maximum ESD voltage - tested to ±26KV
- No capacitive loading
- Eliminates the need for discrete components (such as diodes) and maximizes printed circuit board real estate for equipment housed in conductive enclosures which require ESD protection as freestanding units
- Operating voltage of connectors not effected for most designs
- Pulse life - infinite

ESD protection is standard on the Amphenol Ruggedized VME64x connectors (see page 40) and offers all the above features and benefits.

There are many drop-in replacement ESD protected connectors for retrofitting existing programs which have a conductive enclosure and require ESD protection as free-standing equipment.

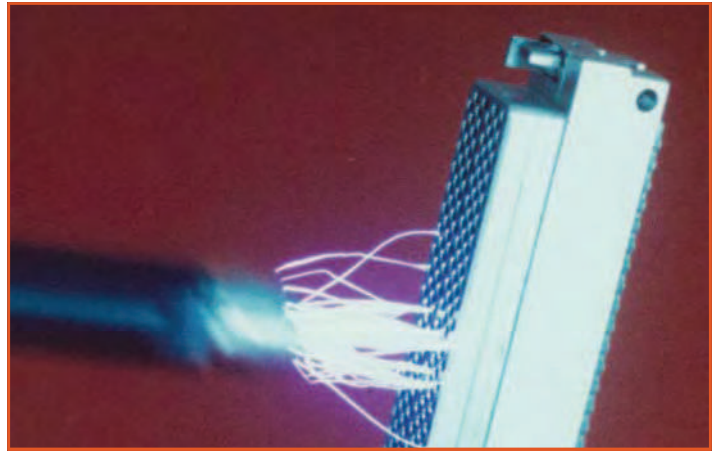

ESD testing on LRM rectangular connector (actual photo)

What is Electrostatic Discharge (ESD)?

Electrostatic Discharge is the rapid transfer of a static electric charge from one body to another. A static electric charge consists of either a surplus or depletion of electrons on a body, which gives that body a potential or voltage relative to ground (or another body). The discharge is extremely fast (less than 1 nano-second risetime) and the current flow may exceed 100 amps!

Static electricity is normally the result of two materials transferring charges when rubbed or separated, such as shoes scuffing across a dry carpet, or sheets of untreated plastic being separated. This phenomena is commonly referred to as the triboelectric effect.

The voltage developed due to the triboelectric effect depends on the materials involved, the quantity and type of contact, and relative humidity. In a dry environment a person can accumulate a charge of up to 25 KV. In a moist environment a person's potential is reduced due to the effect of moisture on the insulating properties of materials.

What is a Faraday Cage?

A Faraday cage is a conductive enclosure. It may be solid in form such as a sheet-metal enclosure, or it may be full of apertures, such as a wire cloth box. When a charge is placed on a faraday cage the electrons which make up the charge, having like polarity, try to position themselves as far as possible from each other. This places the electrons on the outer surface of the enclosure, leaving the inner surface uncharged. The charge on the outer surface does not induce a charge on any neutral object inside of the faraday cage, and therefore does not try to transfer itself onto the internal object. Neutral objects (such as IC's) inside of a faraday cage are thereby protected from ESD activity external to the faraday cage.

The voltage and current observed on neutral objects within a faraday cage during ESD events are due to the secondary effects of ESD. These include Electromagnetic Interference (EMI), magnetic and electrical field coupling. The faraday cage of the Amphenol ESD protected connectors has been designed to minimize these effects.

The Faraday cage on Amphenol ESD protected connectors intercepts electrostatic discharges from the contacts in the unmated state, while maintaining each contact's isolation when the connector is mated.

Publication L-2075, “ESD Attenuation Test Procedure for Connectors with Faraday Cage Protective Structures” is available as a reference document. Contact Amphenol Aerospace for any further information on ESD protection connectors.

Introduction/
Pig-Solutions/
Brush Contact

Suggested/
GEN-X

Fiber Optics/
HiSpeed/R/P/Power

Other Options/Access/
VME/VITA(VIPER)

High Density
HD3
Hi Speed

Standard
Brush

Low Mating Force MIL-DTL-55302
Hybrid - Signal/Power/
Coax/Fiber Optics

Docking Conn./
Accessories/Install.

Rack & Panel
Brush
Ruggedized

LMD/LMS
Rectangular
Interconnects

Other
Rectangular
Interconnects

TEST PROBE KITS

Introduction/
Pkg. Solutions/
Brush Contact

LRM (Line Replaceable Modules)

Other Options/Access./
VME/VITA(VIPER)

Fiber Optics/
Hi Speed/RF/Power

Staggered/
GEN-X

High Density
HSB3
Hi Speed

HSB3
HDB3

Low Mating Force MIL-DTL-55302
Standard
Brush

Coax/Fiber Optics

Hybrids - Signal/Power/
Standard

Low Mating Force
Accessories/Install.

Rack & Panel
Brush
Ruggedized

LMD/LMS
Rectangular
Interconnects

Other
Rectangular
Interconnects

Test Probe Kit - For use with Amphenol Brush Contacts in LRM Connectors

Amphenol supplies a test probe kit especially designed for probing brush contacts to insure that they are properly wired within a connector. It consists of a plastic holder, insert, and two contacts which are usable for either the backplane or module connector. It is suggested that the user buy two kits if they are using connectors of two genders. The kits are not convertible after assembly.

Instructions for use of Backplane Test Probe - Slide the insert back over the wire, and crimp contact on. Follow crimping procedure below. Then snap the insert contact assembly into the holder.

Instructions for use of Module Test Probe - Slide holder over wire, and then crimp contact. Follow crimping procedure below. Slide the insert on the contact and seat it against the shoulder. Slide the holder forward and snap it onto the insert.

Crimping Procedure -

Using accepted industry procedures, strip wire end to be terminated 1/8 to 5/32 inches. Care should be taken not to nick wire strands. Assemble the M22520/2-01 crimp tool and M22520/2-27 positioner and place tool selector in correct setting for wire size. Selected wire size must not have an insulation diameter greater than .062 for the module probe and not greater than .038 for the backplane probe.

AWG	22	24	26	28
SEL	5	4	3	2

Insert stripped wire end into contact wire well. Strands should be visible in wire well inspection hole. Bottom contact and wire assembly in positioner and close handles of crimp tool to complete crimp. Handles will not open unless full crimping cycle has been completed.

Part number for ordering test probe kit is 11-10400-23.

ATTENTION:

Probing brush contacts with anything other than a brush contact may damage or degrade the brush contact performance.



Test probe kit 11-10400-23 components

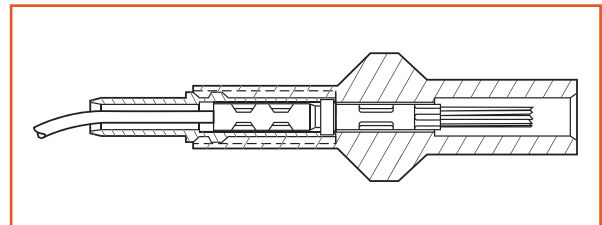

Test probe for brush contact in LRM backplane

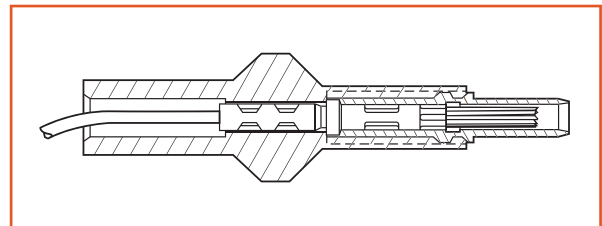

Test probe for brush contact in LRM module

REMOVAL, REPLACEMENT & INSERTION TOOLS

Brush Contact Removal, Replacement and Insertion for Backplane Staggered Grid Connectors

Contacts with solder tails within backplane LRM connectors with staggered grid are not removable or replaceable. User must replace the insert assembly.

Compliant tail type contacts within backplane LRM connectors with staggered grid are removable and replaceable.

Instructions for removal of compliant contacts: From the back of PC board side, push contact out through the front of the connector assembly with contact removal tool #10-507941-1.

Instruction for replacement/insertion of compliant contacts: Using tweezers or fingers, carefully place the replacement contact, tail first, into the appropriate contact cavity in the front of the connector. Tweezer tip must not enter sleeve. Push contact into the cavity with a flat edged rod of suitable diameter to cover entire contact sleeve circumference until contact sleeve is flush with adjacent contacts. Do not push against wires or bend sleeve.

270 VDC Power Module Removal, Replacement and Insertion for Backplane Staggered Grid Connectors

270 VDC power modules can be removed and replaced within the power insert of an LRM connector.

Instructions: Using removal tool #10507924-1 with plunger retracted, push tool down over the power module from the mating end until retention tines are released. Use plunger end of tool to push power module out of the rear the connector.

The power module may be re-installed by hand by pushing it from the rear of the connector. Push it forward until the retention clips snap into the power insert cavity of the shell.

The size 22D power contacts within the power modules are installed and removed with tool M81969/14-01.

For Module Staggered Grid Connectors:

Contacts within module LRM connectors with staggered grid are not removable or replaceable. User must replace the insert assembly.



Removal tool 10-507941-1 for removing compliant contacts from LRM backplanes

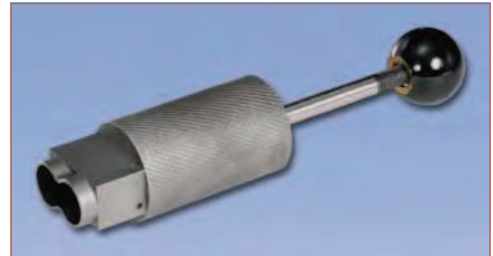

Removal tool 10-507924-1 (plunger retracted) for removing 270 VDC power modules from LRM backplanes

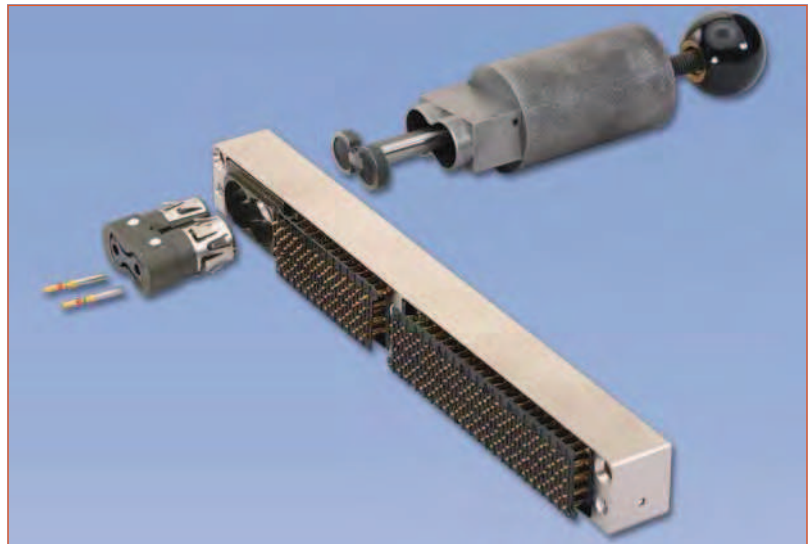

Exploded view - tool 10-507924-1 has removed power module from backplane. (size 22D contacts shown removed)

Introduction/
Pig-Solutions/
Brush Contact

Staggered/
GEN-X

Fiber Optics/
HiSpeed/RF/Power

Other Options/Access/
VME/VITA(VIPER)

High Density
HD33
HSB3
Hi Speed

Low Mating Force MIL-DTL-55302
Standard
Brush
Hybrid - Signal/Power/
Coax/Fiber Optics
Docking Conn./
Accessories/Install.

Rack & Panel
Brush
Ruggedized

LMD/LMS
Rectangular
Interconnects

Other
Rectangular
Interconnects

Introduction/
Pkg. Solutions/
Brush Contact

LRM (Line Replaceable Modules)
Staggered/
GBN-X

Fiber Optics/
Hi Speed/RF/Power

Other Options/Access./
VME/VITA(VIPER)

High Density
HDB3
HSB3
Hi Speed

Low Mating Force MIL-DTL-55302
Standard
Brush

Coax/Fiber Optics

Hybrids - Signal/Power/
Standard
Brush

Hybrids - Signal/Power/
Coax/Fiber Optics

Hybrids - Signal/Power/
Standard
Brush

Hybrids - Signal/Power/
Standard
Brush

Hybrids - Signal/Power/
Standard
Brush

Rack & Panel
Brush
Ruggedized

LMD/LMS
Rectangular
Interconnects

Other
Rectangular
Interconnects

Amphenol Aerospace developed the Ruggedized VME64x in response to the military trend towards VME64x and the utilization of COTS Boards and Chassis.

Many different companies manufacture "Ruggedized VME cards", but they still use the standard VME

COTS (Commercial Off The Shelf) connector interface. In a harsh military environment the COTS VME connector interface can fail, negating the ruggedization of the cards.

The Amphenol Ruggedized VME64x interconnect has a more rugged interface than standard connectors for improved vibration durability. It meets the needs for a harsh environment connector requiring Level 2 maintenance. Military and commercial aviation, military vehicles and GPS systems are examples of markets that need the ruggedized VME64x connector solution from Amphenol.

The Amphenol Ruggedized VME64x connector mounts to standard VME64x cards and backplanes, but it does not mate to other types of VME commercial connectors.

Features and benefits include:

- Metal shells - mount directly to the standard VME card mounting holes, providing support and protection to the inserts in the module and additional stiffness to the backplane
- The metal shells create a faraday cage around the contacts, preventing ESD (Electrostatic Discharge) into the contacts (module only)
- Robust contact system
- 3 module inserts in one unified shell; each can have different interconnect combinations:
 - P1, P2 and 2mm electrical P0
 - P1 and P2 combination
 - P1, P2 and fiber optic MT ferrules in the P0 position
- Inserts are designed to customer specifications
- Thru-hole solder tail or solderless termination is available on the backplane connector.

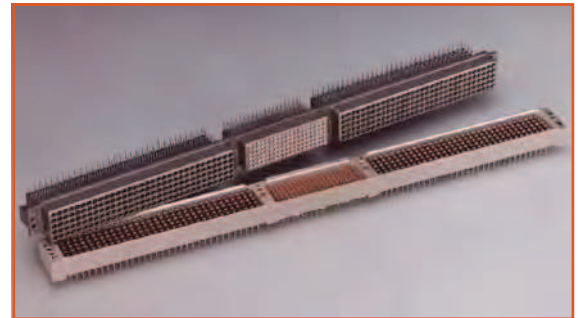

Amphenol's ruggedized VME64x module and backplane connectors were developed to meet more rugged harsh environment applications.

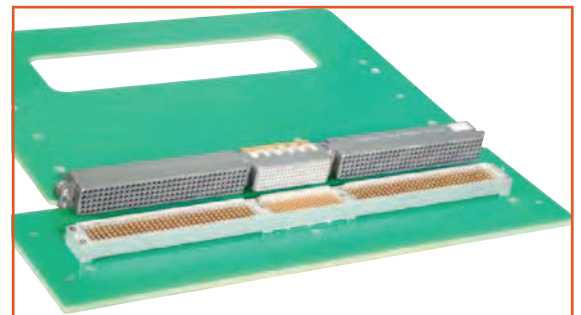

Ruggedized VME64x module and backplane connectors on a circuit board.

Ruggedized VME64x Adapter with Brush Contacts

"Cocooning" of COTS components has been successful in military applications. Amphenol supplies an adapter interconnect system for "cocooning" of COTS VME64x daughtercards.

The ruggedized VME64x adapter system provides the durable brush contact as the primary interface, and integrates the three connectors into a singular metal shell, providing passive ESD protection to the module connector. The back of the module connector mates to standard COTS VME64x daughtercards, isolating them from harsh environments.



Ruggedized VME64x backplane (left), and module adapter (center) and a typical COTS VME64x circuit board (right).

VME P0/J0 Interconnects, VITA Type Interconnects

WITH MT FERRULE FIBER OPTICS

New/Featured Product

VME P0/J0 Fiber Optic Interconnects

Amphenol provides a fiber optic interconnect for attachment to standard VME-64x cards and backplanes for the P0 and J0 locations of the boards. It uses "MT" ferrules and it is used in place of P0/J0 electrical applicable connectors. MT ferrules are not supplied by Amphenol; they must be purchased separately.

Performance features include:

- Tested to IEEE 1156.1-1993
- Operating temperature from -55°C to +125°C
- Shock: 100g, 6ms, 1/2 sine, 18 pulses
Shock: 30g, 6ms, 1/2 sine, 18 pulses
- Sine vibration: 10g, 40 min./axis, 3 axis
- Random vibration: 0.15g² Hz, 40 min./axis, 2 axis
- ESD: 15KV/150 pF

Amphenol's VME P0/J0 fiber optic connectors are used in military and commercial aviation, military vehicles and GPS systems. They are designed to customer specifications. Consult Amphenol Aerospace for further information.

VITA-66.1 Fiber Optic Interconnects

Amphenol's proposed VITA-66.1* MT connector provides a reliable high speed connection for the most extreme commercial and military environments.

This ruggedized interconnect is among the highest density of connector products on the market.

MT ferrules can be accommodated as follows:

- Up to 24 fiber optic channels per MT ferrule
- Up to 48 channels per connector

MT ferrules are not supplied by Amphenol; they must be purchased separately.

Amphenol's VITA 66.1 Interconnect is Designed in accordance with the VPX Technology Roadmap

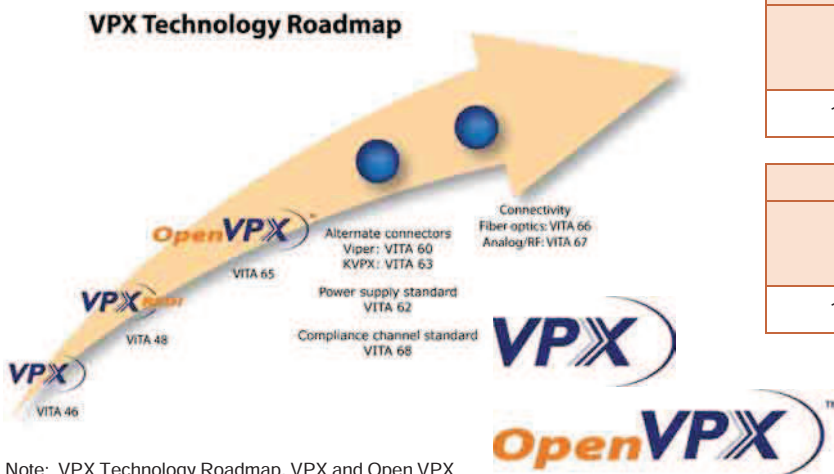

Note: VPX Technology Roadmap, VPX and Open VPX Logos are copywrite to VITA

* VITA-66 supersedes VITA-46.

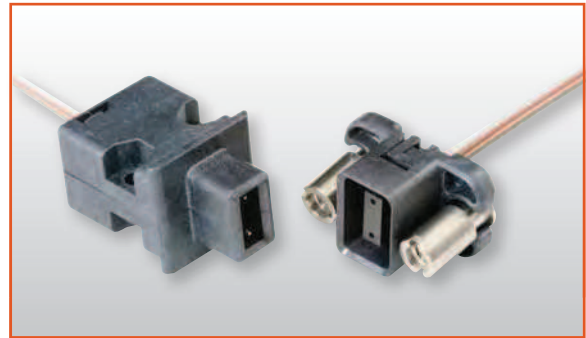

VME P0/J0 Connectors with MT ferrule fiber optics

VME P0/J0 Module MT Connector Part Number	VME P0/J0 Backplane MT Connector Part Number
10-509050-011	10-509050-041



VITA-66.1 Connectors with MT ferrule fiber optics

VITA-66 Connectors with 2mm Dual Spring	
Module MT Connector Part Number	Backplane MT Connector Part Number
10-504637-002	10-504639-002

VITA-66 Connectors	
Module MT Connector Part Number	Backplane MT Connector Part Number
10-504637-004	10-504639-002

Introduction/
Pig. Solutions/
Brush Contact

Suggested/
GEN-X

Fiber Optics/
HiSpeed/RF/Power

Other Options/Access/
VME/VITA(VIPRR)

LRM (Line Replaceable Modules)

High Density
HD33
HSB3
Hi Speed

Low Mating Force MIL-DTL-55302
Standard
Brush

Hybrid - Signal/Power/
Coax/Fiber Optics

Docking Conn./
Accessories/Install.

Rack & Panel
Brush
Ruggedized

LMD/LMS
Rectangular
Interconnects

Other
Rectangular
Interconnects