

PYROTENAX SPACE SAVING CABLE SYSTEM



This section provides an overview of general circuit design considerations and installation guidelines for Pyrotenax System 1850 Power Cables in space savings applications. For additional information, contact your Pentair Thermal Building Solutions representative or phone Pentair Thermal Building Solutions at (800) 545-6258. Also, visit our web site at www.pentairthermal.com.

CONTENTS

Introduction	2
Typical Locations	2
System 1850 Mineral Insulated Cable	2
Construction.	2
Configurations	2
Approvals and Certifications	3
Circuit Design Considerations	3
Cable Sizing.	3
Voltage Drop	4
Equipment Bonding	4
Short Circuit Capability.	5
Expansion and Vibration.	5
Corrosion and Copper-armored Cables	5
Cable Termination.	6
Cable Splices.	7
Typical Space Saving System Installation	8
Installation Guidelines	9
Supporting Space Saving MI Cables	9
Seismic Considerations	9
Cable Layout	9
Terminating System 1850 MI Cables.	11
Connecting System 1850 MI Cable	11

INTRODUCTION

Increased power consumption due to the expansion of office space in existing buildings, as well as the conversion of buildings to commercial use, has resulted in greater demand for the retrofitting of electrical power feeders. In many instances, this involves installing power cable in constricted spaces and along difficult runs.

Pentair Pyrotenax System 1850 mineral insulated (MI) power cable allows up to 80% space savings over traditional rigid conduit and wire solutions, and are easily installed in areas where space is limited.

Typical Locations

System 1850 MI power cables, when used in space saving applications, are ideal for high capacity feeders and low profile wiring in the following locations:

- Older high-rise buildings
- Historic buildings
- Health care facilities
- Any location where space is limited

System 1850 Mineral Insulated Cable

System 1850 MI cable offers a unique combination of dependability, versatility, and permanence while capable of operating continuously at ambient temperatures as high as 250°C (482°F).

CONSTRUCTION

Pyrotenax System 1850 MI cables are manufactured using only inorganic materials, copper and magnesium oxide. This construction is inherently tough, yet allows the cable to be bent and molded to fit into tight spaces. In addition, the totally inorganic construction of unjacketed System 1850 MI cable allows for an environmentally clean electrical cable that does not burn, produce smoke, or add fuel when exposed to fire conditions.

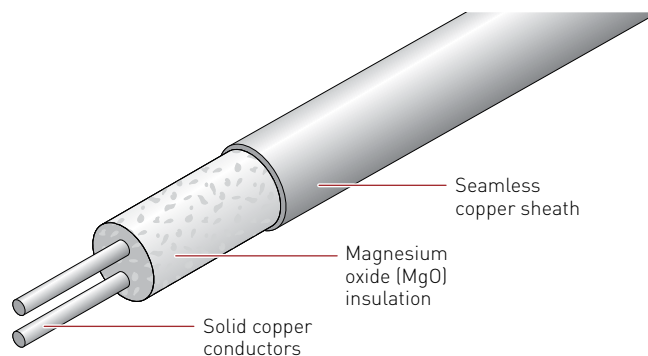

Fig. 1 System 1850 MI cable construction

System 1850 MI cables have a seamless metal sheath that allows the cable to withstand bending, twisting, pulling, and mechanical abrasion, while remaining fully functional. For superior corrosion protection, an optional polymer jacket is available and is suitable for use in temperatures as low as -40°C (-40°F).

CONFIGURATIONS

System 1850 MI cables are available in a range of sizes and conductor configurations, allowing for use in a diverse range of applications. For specifications, see the product data sheet in the Technical Data section.

Approvals and Certifications

Pyrotenax System 1850 MI cables meet the applicable requirements of the U.S. National Electrical Code (NEC) and the Canadian Electrical Code (CEC), and are UL Listed and CSA Certified in North America.

Factory terminated MI cable sets are approved for nonhazardous locations and hazardous locations. For specific approval information, see the product data sheet in the Technical Data section.

Pyrotenax power cables are also available for use outside North America and are manufactured to BS EN 60702-1 & 60702-2, Mineral Insulated Cables and Terminations. Contact Pentair for information on our range of cables certified for use worldwide.

CIRCUIT DESIGN CONSIDERATIONS

Power cable systems should only be designed by professionals familiar with generally accepted design practices. The information provided below relates specifically to designs using Pyrotenax MI power cables and must be followed, along with all relevant local codes and standards, to ensure that the systems are designed properly. For additional information, contact your Pentair representative or phone Pentair at (800) 545-6258.

Cable Sizing

Power cable size is based on circuit breaker size, which in turn is based on load calculations. Special rules apply for motors where cable size is based on 125% of full load current. Use the ampacity tables specified in the electrical code to determine the cable size. If the calculated voltage drop exceeds the specified limits, a larger cable size must be chosen.

The NEC and CEC allow full "free air" ampacity for unjacketed single conductor Pyrotenax MI cables configured according to Fig. 2 as long as a space of 2.15 cable diameters is maintained between bundles.

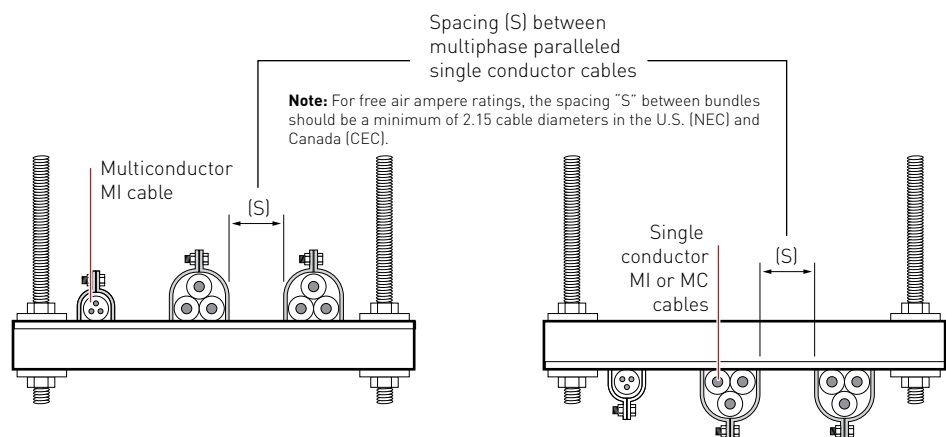

Fig. 2 Spacing of bundled conductors

Under the installation conditions shown in Fig. 2, the termination may need to be "sized-up" to keep it within its temperature limits in accordance with electrical code requirements (NEC 110.14(C)). MI cable terminations should be sized up in accordance with the installation instructions supplied with the termination kit.

SPACE SAVING CABLE SYSTEM

Voltage Drop

Voltage drop calculations are based on calculated load, not circuit breaker rating.

For conventional cables, simple formulas are used to determine if the cable size listed in the ampacity tables meets the required voltage drop limits. While these formulas can be applied to System 1850 MI cable, voltage drop values specific to the characteristics of MI cable can be calculated using any of the following:

- A quick voltage drop calculator is available on the Pentair web site, www.pentairthermal.com
- PyroSizer MI cable sizing software is available on the Pentair web site, www.pentairthermal.com, or through your Pentair representative

Equipment Bonding

The copper sheath of System 1850 MI cables meets North American code requirements for an equipment grounding conductor. The brass gland completes the grounding path from the cable sheath to the equipment. For single conductor cables, the ground path includes a nonferrous brass plate as shown in Fig. 3 (in Canada, brass plates are required only for ampacities over 200 A).

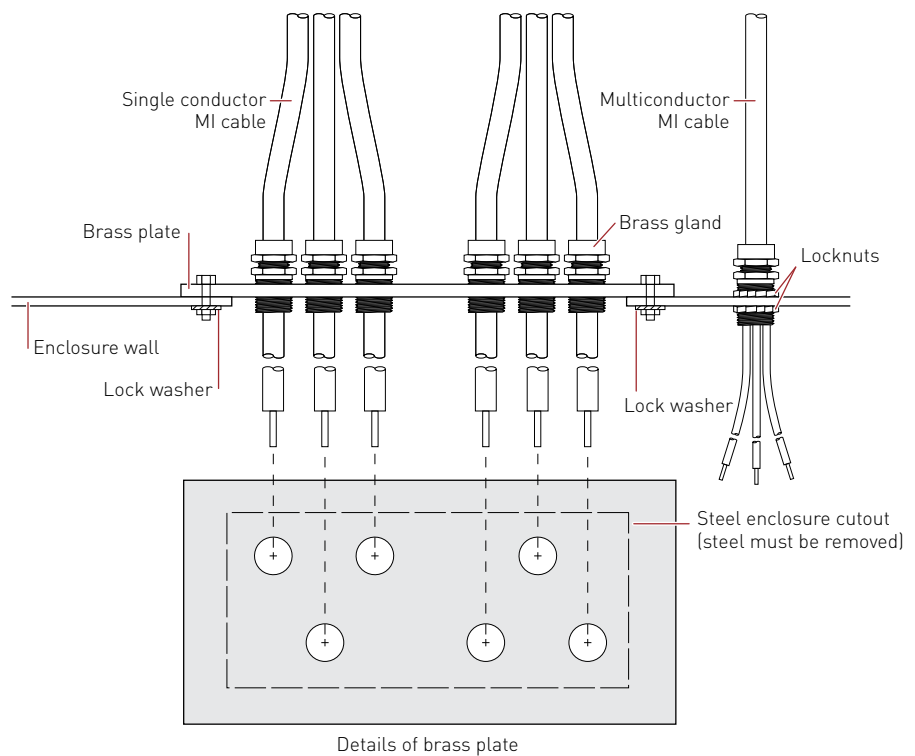

Fig. 3 Equipment bonding using brass plate

Short Circuit Capability

The following graphs give the maximum allowable short circuit currents for System 1850 MI cables. The first is based on the cable only. The cable will survive if the short circuit currents shown are not exceeded; however, the terminations could be damaged. The second graph provides the maximum short circuit current to avoid damaging the terminations.

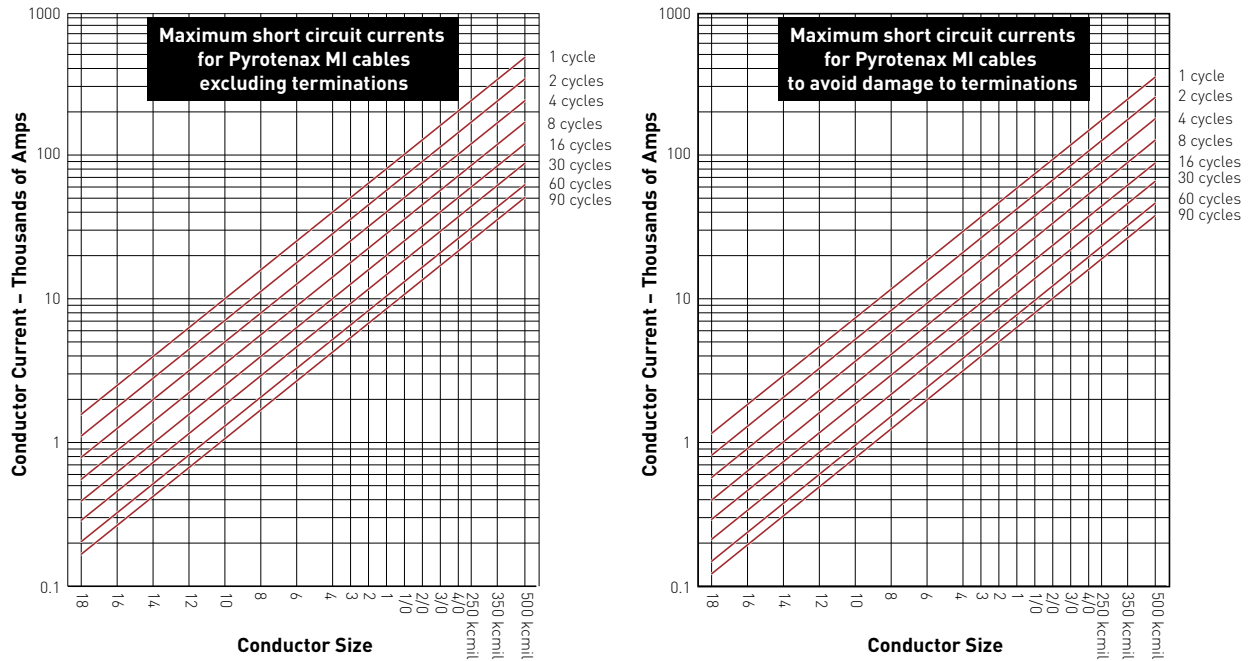

Fig. 4 Short circuit currents for System 1850 MI cable

Expansion and Vibration

In applications subject to expansion or vibration, take precautions to prevent mechanical damage to System 1850 MI cables. Refer to: Pyrotex MI Cable Expansion and Vibration (H57613) for details.

Corrosion and Copper-armored Cables

In most applications, System 1850 MI cables can be used without any additional protection against corrosion. However, in applications where the cable may be exposed to corrosives, such as when the cable is directly buried or embedded in concrete, additional protection in the form of a polymer jacket is recommended. Refer to: Copper Sheathed Cable and Corrosion (H57614) for details.

SPACE SAVING CABLE SYSTEM

Cable Termination

System 1850 MI cables are approved as a complete system only when used with the appropriate Pyrotenax termination and splice kits. The use of nonapproved components will compromise the reliability of the system and will invalidate approvals and warranties.

Two types of termination kits are available: Pyropak kits for all single and multiconductor cables, and QuickTerm kits for # 6 AWG and larger single conductor cables. The QuickTerm kits include a special connector to splice the solid MI conductor to a flexible tail (flexible tail not supplied).

Factory terminated System 1850 MI cable sets are available in a range of sizes and lengths. For details on terminated cable sets, contact your Pentair representative or phone Pentair at (800) 545-6258.

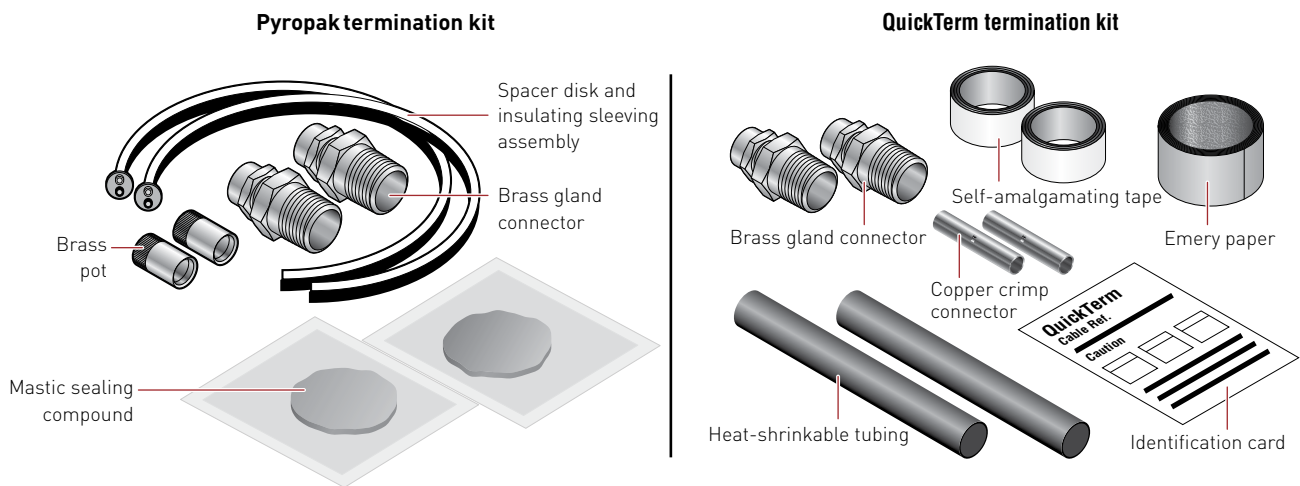

Fig. 5 Terminations for System 1850 MI cable

Cable Splices

In cases where the manufactured length is shorter than the required run length, a splice is used to join individual lengths of cable. Two options for splicing System 1850 MI cable are available:

Field-installed splice: A field-installed splice kit is available to extend the cable length or to repair a damaged cable.

Factory splice: An all-welded factory installed splice is available to extend the cable length.

Field-installed splice

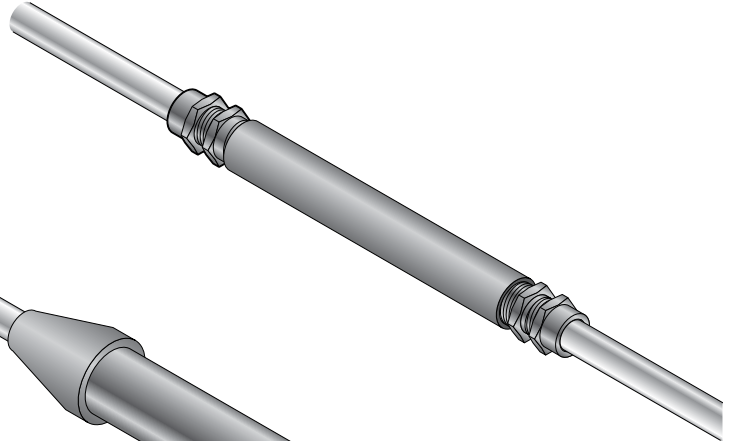

Factory splice

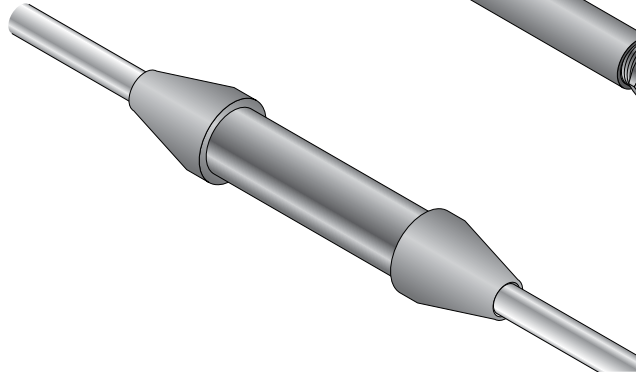

Fig. 6 Splices for System 1850 space saving MI cable

SPACE SAVING CABLE SYSTEM

Typical Space Saving System Installation

A typical space saving power circuit installation utilizing System 1850 MI cable is shown in Figure 7. Additionally, components and accessories available for single and multiconductor MI cables are shown in Table 1. For further information on components and accessories, see the product data sheet in the Technical Data section.

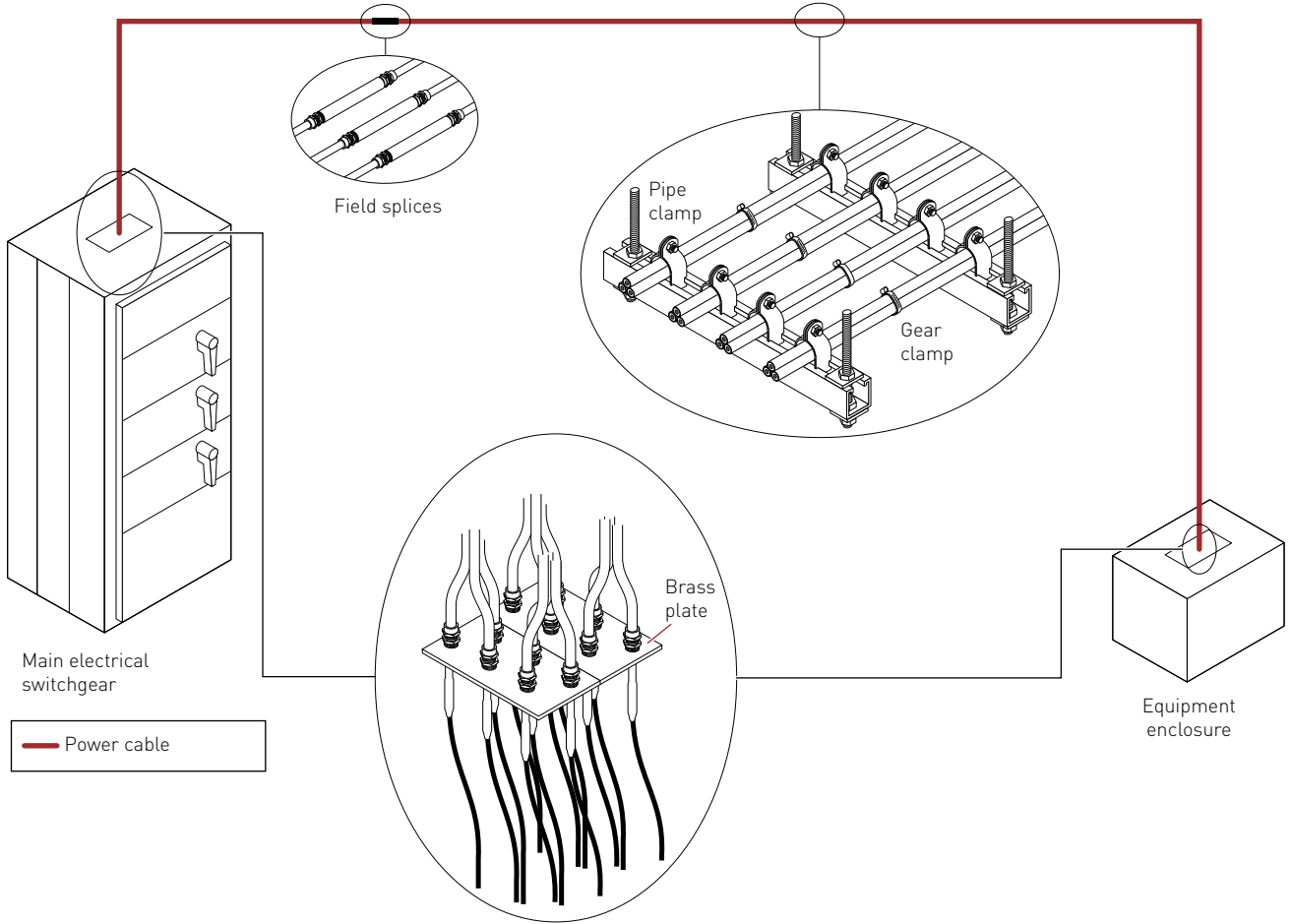

Fig. 7 Typical single conductor System 1850 space saving power cable system

TABLE 1 COMPONENT AND ACCESSORY AVAILABILITY FOR SYSTEM 1850 MI POWER CABLE

	Single conductor MI	Multiconductor MI
Pyropak termination kit	•	•
QuickTerm termination kit	•	•
Field and factory splices	•	•
Brass plates	•	•

INSTALLATION GUIDELINES

These installation guidelines apply to System 1850 MI cables used in space saving applications. For further details, refer to national and local electrical codes, the System 1850 data sheet, and the installation instructions shipped with the product. The data sheet and installation instructions are available on the Pentair web site at www.pentairthermal.com. Contact your Pentair representative or phone Pentair at (800) 545-6258 for additional information.

Supporting Space Saving MI Cables

System 1850 MI cables used in space savings applications may be directly mounted on any surface or supported by rod and channel (trapeze) systems. To achieve free air rating, spacing must be maintained between the cable bundles and also between the bundles and the mounting surface; refer to Fig. 8. Pentair and electrical codes require support spacing at certain intervals; refer to the installation instructions shipped with the product and available on the Pentair web site, www.pentairthermal.com.

Other than transitions through a wall, floor, or ceiling, MI cable should not be installed in conduit.

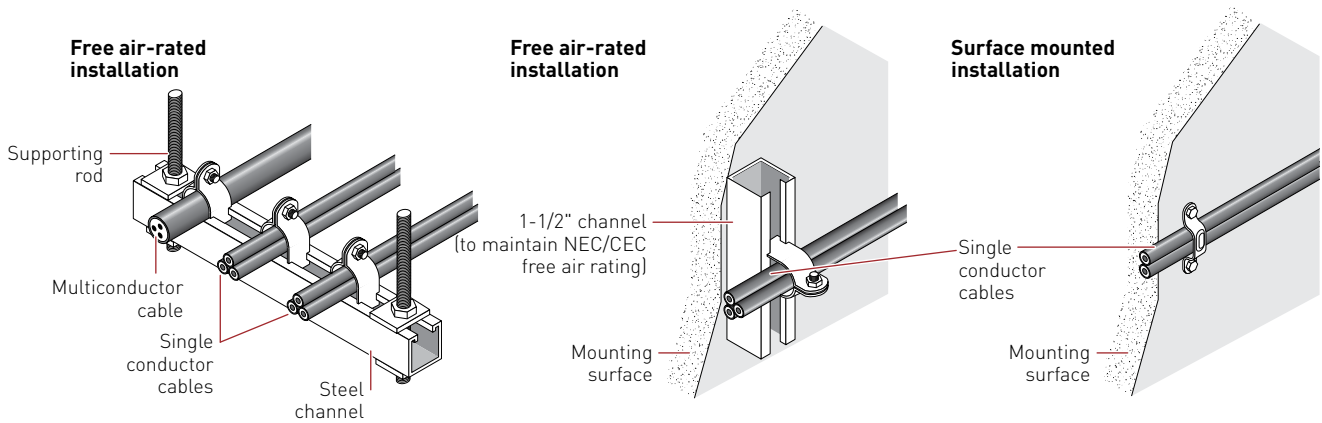

Fig. 8 System 1850 MI cables in space savings applications

Seismic Considerations

In areas where there is a risk of seismic activity, precautions must be taken where the cable crosses expansion joints and at termination points. Refer to: Pyrotex MI Cable Expansion and Vibration (H57613) for details.

Cable Layout

In multiconductor cables, the magnetic effects of the phase conductors cancel each other out, allowing for cable installation in any configuration. However, single conductor cables should be bundled in groups containing one conductor from each phase to minimize the resulting magnetic field in each grouping. The grouped single conductor cables are then fastened tightly together, ensuring that the gland connectors at each end of the cable run are connected to the metal enclosure through a nonferrous entry, such as a brass plate, or in accordance with national electrical codes. Typical single conductor cable configurations are shown in Fig. 9. The neutral conductor may be located within or outside the cable group.

SPACE SAVING CABLE SYSTEM

	Single Phase	Three-Phase • 3 Wire	Three-Phase • 4 Wire
Single circuit (preferred)			
Single circuit (alternative)			
Two cables in parallel per phase (preferred)			
Two cables in parallel per phase (alternative)			
Three or more cables in parallel per phase (preferred)			
Three or more cables in parallel per phase (alternative)			

Note: For free air ampere ratings, the spacing "S" between bundles should be a minimum of 2.15 cable diameters in the U.S. (NEC) and Canada (CEC). For magnetic effect purposes, the neutral may be located as shown, or outside groups in the most convenient location.

Fig. 9 Recommended installation configurations

Electrical codes generally limit paralleling cable configurations to cable sizes 1/0 AWG and larger. The codes address the balancing of resistance by stipulating:

- All conductors must be the same length
- All conductors must be the same size and the same material
- All conductors must have the same type of insulation
- All conductors must be terminated in the same manner

A current measurement should be taken immediately after the cables begin to carry load. Load imbalances between conductors of up to 10% are tolerable and expected. Deviations above 10% must be investigated and corrected.

When installing single conductor cables through a ferrous enclosure, precautions must be taken to prevent induction heating in the steel. This is accomplished by removing a section of the enclosure and installing a nonferrous brass plate (in Canada, this is only required above 200 A). Brass plates with pretapped holes are available for the gland connectors.

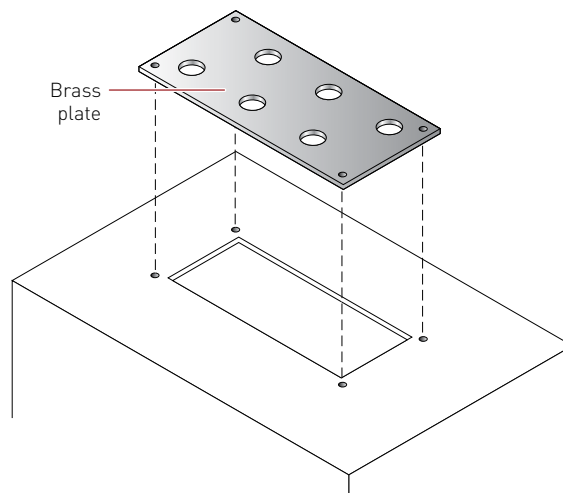

Fig. 10 Enclosure with cutout and brass plate

Terminating System 1850 MI Cables

Details on terminating System 1850 MI cables can be found in the installation instructions provided with each System 1850 MI cable termination kit.

Factory terminated System 1850 MI cable sets are available in a range of sizes and lengths. For details on terminated cable sets, contact your Pentair representative or phone Pentair at (800) 545-6258.

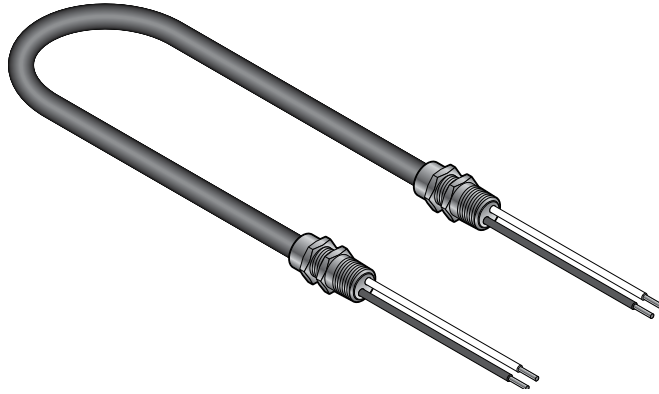

Fig. 11 Factory terminated System 1850 MI cable

Connecting System 1850 MI Cable

The termination gland is a brass fitting available in standard NPT sizes. The glands are supplied in 1/2", 3/4", 1", or 1-1/4" sizes, depending on the cable diameter.

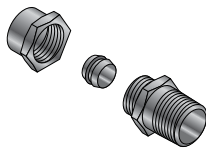

Fig. 12 Brass gland

Gland size information for each MI cable is available from the product data sheets in the Technical Data section. When tightened with the recommended torque (25 ft-lbs), this gland simultaneously seals the enclosure and grips the cable through a brass compression sleeve. This connection, when installed according to the installation instructions, provides the following benefits:

- Code-compliant bonding path through the cable sheath
- Hydrostatic withstand pressure up to 500 lbs/in² (35 kg/cm²)



WWW.PENTAIRTHERMAL.COM

NORTH AMERICA

Tel: +1.800.545.6258
Fax: +1.800.527.5703
Tel: +1.650.216.1526
Fax: +1.650.474.7711
thermal.info@pentair.com

EUROPE, MIDDLE EAST, AFRICA

Tel: +32.16.213.511
Fax: +32.16.213.603
thermal.info@pentair.com

ASIA PACIFIC

Tel: +86.21.2412.1688
Fax: +86.21.5426.2937
cn.thermal.info@pentair.com

LATIN AMERICA

Tel: +1.713.868.4800
Fax: +1.713.868.2333
thermal.info@pentair.com

Pentair is owned by Pentair or its global affiliates. All other trademarks are the property of their respective owners. Pentair reserves the right to change specifications without prior notice.

© 2004-2016 Pentair.

@pentairTBS