

TECHNICAL GUIDE SPECIFICATIONS	
Power Ride 4	
Three Phase, (48 KW-128KW) UL924 Central Lighting Inverter (Also available up to 400 KW)	

1.0 GENERAL

1.1 SCOPE:

Central Lighting Inverter specification defines a high reliability three-phase, on-line, True Galvanic Isolated UPS - double conversion, digital signal processing, high frequency pulse width modulated (PWM) system, utilizing IGBTs.

It shall be designed to provide high quality regulated and conditioned AC power to all lighting loads at all times. The unit shall be specifically designed to meet UL 924 for emergency lighting applications and provide 90 minutes of battery back up. It shall be suitable for all lighting loads including any combination of electronic and security system, power factor corrected, self-ballast Fluorescent, Incandescent, Quartz Re-strike, Halogen, HID and HPS during emergency backup.

System shall be operating for the minimum of 90 minutes with 100% load. Upon return of the normal AC utility line, system shall return to normal mode automatically without any interruption of power to the load. The charging system shall recharge the battery within UL 924 requirements. The lighting inverter uses industry distinctive small footprint cabinet design allowing for equipment installation in limited spaces.

1.2 STANDARDS: The Inverter shall comply with the following standards:

- A – ETL Certified per UL1778, UL924
CSA STD C22.2 NO./07.3-0
- B – ETL Certified to UL 924, Emergency Lighting and Power Equipment/
Auxiliary lighting and Power Equipment.
- D - FCC rules and regulations, Part 15, subpart j, class A
- E – NEMA PE-1
- F – NFPA 101 (Life safety code)
- G – ANSI C62.41 (IEEE 587)

2.0 PRODUCT DESCRIPTION

2.1 APPROVED MANUFACTURERS AND PRODUCT DESCRIPTION

- 2.1.1 Approved Manufacturer:** The Inverter shall be an Emergency Central Lighting Inverter and shall be manufactured by:

PERFECT POWER SYSTEMS

5701 Smithway Street, Commerce, CA 90040.

Phone: (800) 786-6915, Fax: (323) 721-3929

Power Service – 1 800 797 7782

2.2 QUALIFICATIONS AND QUALITY ASSURANCE

2.2.1 Manufacturer's Certification: A minimum of twenty years experience in the design, manufacture and testing of solid-state Inverter is required. The manufacturer shall specialize in manufacturing of on-line, double conversion high frequency Inverter modules specified in this document. The manufacturer shall hold a current ISO 9001-2000 certification and shall design the units in accordance with internationally accepted standards.

2.2.2 Materials and Assemblies: All materials and parts in the Inverter shall be new, of current manufacture, unused, except for the purpose of factory testing. All active electronic components shall be solid state and designed as to not exceed the manufacturer's recommended ratings and tolerances for ensuring maximum reliability. All IGBTs and other semiconductor devices shall be sealed. All relays shall have dust covers. All incoming parts, modular assemblies and sheet metal shall undergo detailed receiving quality inspection.

2.2.3 Factory Testing: Every unit shipped will have completed a documented functional test of the Inverter module and a battery system, including a battery discharge test. A copy of the test report shall be available upon customer's request.

2.3 Operation

The system shall utilize High Frequency Pulse Width Modulation, digital signal processing for control and monitoring. The system shall have the capability of operating in 2 modes, Double Conversion mode through inverter for supporting the critical load at all time with no switching during a power outage, or Green mode through static switch for better efficiency with fast transfer time (less than 2 milliseconds) and compatibility with all type of lightings.

The system's automatic-overload and short circuit protection of the inverter in normal and emergency operations shall consist of 150% momentary surge capability for 30 seconds and 110-125% overload for 15 minutes. The system protection shall also include a low-battery voltage disconnect to prevent damages to the battery bank. The system shall supply a clean computer grade sinusoidal output waveform with less than 2% total harmonic distortion at full rated load. Dynamic brownout protection will maintain the desired voltage without continuously switching to batteries in low voltage situations up to -15%. The system shall maintain output regulation of less than $\pm 1\%$ at all operating condition except overload and short circuit. The system shall be able to protect its self from internal over-temperature condition in the event of internal cooling condition and issue an alarm under such condition.

The system shall consist of circuitry including an automatic, multi-rate, software-controlled charger; self-diagnostic, programmable system testing capabilities a microprocessor-controlled, diagnostic display panel capable of audible alarms and visual displays of all alarm and inverter; a DC to AC converter (inverter); a battery charger that meet UL 924 standard; an AC input breaker and DC fuses for protection; a battery-bank sized for the system's runtime requirements at full rating, and an RS232 communication interface.

2.4 Technical Specification

2.4.1 AC input Specifications:

- **Input voltage range:** 208/120V $\pm 15\%$ or 480/277 $\pm 15\%$
- **Input Frequency:** 50/60 Hz $\pm 7\%$
- **Input Power factor:** 0.8 PF
- **Power walk-in time:** 20 sec from 0 to 100%
- **Input current harmonics:**
 - 33% for 6 pulse rectifier unit.
 - 15% for 12 pulse rectifier unit.
 - 9% input filter option is available.

2.4.2 Battery Specification:

- **Battery type:** Maintenance free sealed lead acid (*Standard*)
- **Voltage:** 348VDC (Range: 295-410VDC)
- **Low Battery Warning Voltage:** 320VDC
- **Low Battery Shut down Voltage:** 295VDC
- **Boost Charge Voltage:** 402VDC
- **Float Charge Voltage:** 390VDC
- **Standard Run Time:** 90 minutes for UL924. *For battery cabinet dimensions including other run time (refer to battery Table 2 and Tabel 2A).*

2.4.3 Inverter and Output Specification:

- **DC input Voltage Range to Inverter:** 285-420VDC (*inverter can be started without an AC source*)
- **Output Waveform:** Sinusoidal Wave
- **Output Power factor:** 0.8 PF
- **Output Voltage Regulation at 100% Unbalanced Load:** $\pm 1\%$
- **Output Frequency Tolerance:** ± 0.1 Hz
- **Phase Shift Under 100% Unbalanced Load:** $120^\circ \pm 0.5\%$
- **Output Voltage Total Harmonics (THD):** Less than 2%
- **Output Maximum Peak Current (AMP):** +125% of Rated Output current.

- **Over Load:**
 - **Less than 110% Load:** Continuous
 - **125-150%:** 5 minutes
 - **Higher than 150%:** 30 Seconds

2.4.4 Static Switch Specification:

- **Voltage Range:**
 - 96-144VAC (Line to Neutral) for 208/120V units
 - 222-332VAC (Line to Neutral) for 480/277V units.
- **Efficiency:** 99.5%
- **Transfer Time:**
 - **From Main Input source to Inverter:** 0.2ms
 - **From Inverter to Main Input source:** 0.2ms

- **Over Load:**
 - **100% for 30 Seconds**
 - **300% for 7 Seconds**
- **Isolation with Output**

2.4.5 System Overall Specification:

- **Operation Mode:**
Double conversion mode
Green Mode: Hybrid design; customer selectable for green mode (fast transfer less than 2ms).
- **Overall System Efficiency (Double conversion mode) :** 91%~93% (Vary by kVA)
- **Overall System Efficiency (Green Mode) :** 96%~98% (Vary by kVA)
- **Overload: 110-125%:**15 minutes/**125-150%:** 5 minutes/**Higher than 150%:** 30 Seconds
- **Operating Environment:**
 - **Operating Temperature:** 0 ~ 40° C (32° F ~104° F)
 - **Humidity:** 0 ~ 90% (None Condensing)
 - **Altitude:** Less than 1500 meter (5000 feet) Above Sea level
- **Maximum Heat Dissipation:**
 - **BTU/HR:** Refer to the Table 3
 - **Weight:** Refer to the Table 3
 - **Dimensions:** Refer to the Table 3
- **Audible Noise:** Less than 65dBA at 1 meter/39.4 inches
- **Protections:**
 - Short Circuit for Rectifier/By-pass

- MOV for Lightning
- EMC Filter for Input and Output
- **Status Panel:**
 - It shall consist of 4 X 40 character LCD display for real time status, Data or Historical Events
 - 24 Status LEDs, 8 Warning LEDs
 - Mimic Display
 - Audible Alarm
 - Inverter ON/OFF Switch
 - LCD control Switch.

2.5 Features and Advantages:

- **Reliable input protection:** The UPS shall utilize Circuit breakers in each individual input loop to ensure power can continue through another loop in case of breaker trip caused by an abnormal condition in either rectifier or load.
- **Input surge protection:** The UPS shall employ MOV (surge protector) on the input, providing protection to both UPS and the load from any lightning surges, or surges caused by neighboring large loads.
- **EMI suppression:** The UPS shall employ an EMI filter to meet the international EMC limits. Therefore, very low noise is emitted, and no interference is supplied to other equipment connected to the same AC source.
- **Ruggedness:** The rectifier shall employ phase control technology to regulate the DC bus voltage. This is the most efficient method to charge the batteries.
- **High frequency design:** The inverter shall use high frequency, high efficiency IGBT, PWM methodology to convert the DC power to AC power, therefore reducing the number of components, improving reliability, reducing the size and weight of UPS, while improving performance and minimizing acoustic noise.
- **Plug & Play Modular design:** The system shall use module power circuit pluggable into slots in the UPS, for ease of maintenance and troubleshooting.
- **Cold start function:** The UPS shall start without an AC source, (with battery power only), By adding current limit circuitry to prevent large inrush current blowing the battery fuse and damaging the DC capacitors when batteries are connected to an empty DC bus (before the DC bus is energized).
- **Multi-CPU design:** The UPS shall employ several CPUs in the control circuit, and critical functions design with parallel redundancy to improve reliability. Therefore, in case of one CPU failure, the other CPUs keep the UPS operational, and the output AC is not affected.
- **Protection against misuse:** The UPS shall be designed with breaker on/off sensor, power supply sensor, etc. to prevent harm to the UPS caused by user error.

- **Accepts wide input range:** The UPS shall accept wide input range, so that it can work effectively under an unstable AC source. All of the input components used are specifically selected to handle extreme high voltage and high current.
- **Intelligent charger:** The UPS shall automatically recharge (boost charge) the batteries every time the batteries are depleted to a voltage level equal to 2V/Cell. Thus, the batteries can be restored to full capacity as soon as possible, and made ready for the next back-up requirement. In order to keep the batteries in the best condition, the UPS will boost charge the batteries for several hours (selectable) automatically every month. To avoid over charging the batteries, boost charge will stop when the ambient temperature is over 35°C (95°F).
- **Intelligent battery test:** The batteries shall test after every boost (initiated by battery discharge or by the monthly boost charge cycle). This shall be done without interrupting the operation of the rectifier, preventing the risk of output AC failure in case of a defective battery and inform the user of the battery condition, so that action can be taken before the full capacity of the batteries is needed.
- **MTBF of fans are extended:** Fans used to cool the UPS, are designed to slow down under light load, so that the life expectancy of the fans is extended beyond the normal.
- **Redundant power supply:** A supplemental power supply is added to provide redundancy for supplying power to the static switch, so that there will be AC output no matter what happens to the UPS.
- **Options:** refer to detail for this section.

2.5.1 Model Number: *Refer to Table 1*

2.5.2 Battery Table UL924 (90 Minutes):
Refer to Table 2

2.5.3 Input/Output protective device rating and current calculation and floor loading: *Refer to Table 3*

MODEL NUMBERS			
kW	MODEL NO.	INPUT VOLTAGE	OUTPUT VOLTAGE
8 kW	PD010B05ATT3	208Y/120	208Y/120
	PD010H09ATT3	480Y/277	480Y/277
16 kW	PD020B05ATT3	208Y/120	208Y/120
	PD020H09ATT3	480Y/277	480Y/277
24kW	PD030B05ATT3	208Y/120	208Y/120
	PD030H09ATT3	480Y/277	480Y/277
32 kW	PD040B05ATT3	208Y/120	208Y/120
	PD040H09ATT3	480Y/277	480Y/277
40kW	PD050B05ATT3	208Y/120	208Y/120
	PD050H09ATT3	480Y/277	480Y/277
48kW	PD060B05ATT3	208Y/120	208Y/120
	PD060H09ATT3	480Y/277	480Y/277
64kW	PD080B05ATT3	208Y/120	208Y/120
	PD080H09ATT3	480Y/277	480Y/277
80kW	PD100B05ATT3	208Y/120	208Y/120
	PD100H09ATT3	480Y/277	480Y/277
96kW	PD120B05ATT3	208Y/120	208Y/120
	PD120H09ATT3	480Y/277	480Y/277
128kW	PD160B05ATT3	208Y/120	208Y/120
	PD160H09ATT3	480Y/277	480Y/277
160kW	PD200B05ATT3	208Y/120	208Y/120
	PD200H09ATT3	480Y/277	480Y/277
192kW	PD240B05ATT3	208Y/120	208Y/120
	PD240H09ATT3	480Y/277	480Y/277
240kW	PD300B05ATT3	208Y/120	208Y/120
	PD300H09ATT3	480Y/277	480Y/277
320kW	PD400B05ATT3	208Y/120	208Y/120
	PD400H09ATT3	480Y/277	480Y/277
400kW	PD500B05ATT3	208Y/120	208Y/120
	PD500H09ATT3	480Y/277	480Y/277
* Consult Factory for application			

TABLE 1

2.6 Components Description

2.6.1 Rectifier

The main function of a rectifier is to convert the AC input to DC power, and supply it to the inverter. The inverter then converts the DC power to AC power for the load. The UPS use the DC power to charge the batteries as well, which is the most efficient method of charging.

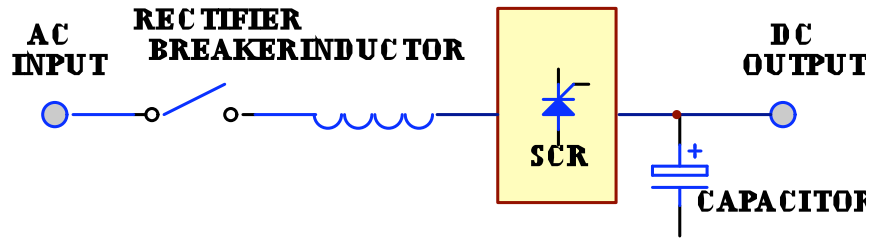

6-PULSE FULL CONTROL RECTIFIER

UPS units 60KVA to 100KVA shall use 6-pulse fully controlled rectification (optional 12-pulse). An inductor is added before the rectifier to improve the power factor, smooth the current waveform and eliminate the harmonic current. The control circuit regulates the DC bus within 1%. Soft walk-in circuitry (approximately 20sec.) and current limit circuitry is used to prevent over current or instantaneous surge current.

Extra under-voltage and over-voltage protections are added to improve reliability and to shutdown the rectifier in case of abnormal conditions. The DC bus is adjustable to fit different types of batteries. The power component used in the rectifier is specially selected to handle extreme high voltage and high current. The rectifier is designed to operate under a wide range of AC input, from 177 to 300VAC, to operate under the poor power conditions found in some areas.

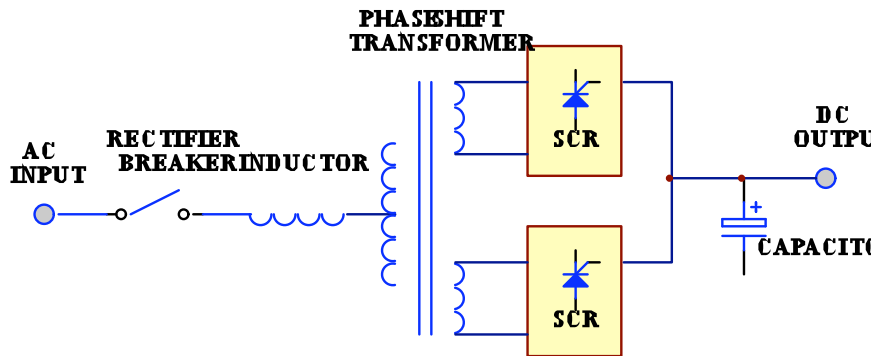

12-PULSE FULL CONTROL RECTIFIER

In order to further improve the power factor and reduce harmonic current drawn by the rectifier, UPS at 120KVA and above, use the 12-pulse full controlled rectifier. The total current harmonic current can be reduced to around 15%, and power factor improved to over 0.8. A phase shift transformer is added to achieve this performance. The input inductor is retained also to obtain the best result. Although this results in higher cost, the unit is much more reliable and rugged. Users do not need to increase the input breaker and cable sizes, since input KVA and harmonic current drawn is minimized, fulfilling the worldwide energy saving requirements.

The harmonic current can be further lowered by adding harmonic filters (factory installation available). The total harmonic current can be reduced to approximately 9%.

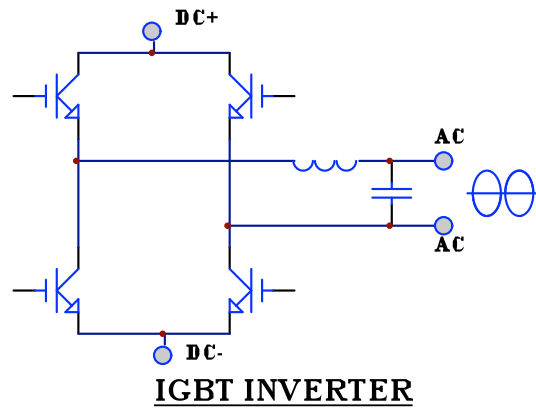

The inverter is composed of IGBT, inductor, capacitor, snubber, control circuitry and protection circuitry. The inverter converts the DC power from the DC bus to AC power to supply the output load. The UPS uses IGBT technology which switches at frequencies beyond the audible range, therefore producing no audible noise.

The UPS uses voltage regulation circuitry to limit the voltage variation within 1%. Special compensation circuitry is added to eliminate the output distortion. Every component is oversized to accept the wide DC input range (from 285 to 420VDC), so that the output waveform remains sinusoidal throughout the range. With the aid of dynamic feedback loop the inverter will keep a sine waveform even under non-linear load.

An independent inverter is used for each phase. Although it is more expensive, each inverter has its independent feedback, so that the voltage is unaffected when load is added to the adjacent phase, producing excellent voltage regulation under 100% unbalanced load.

The IGBT is operated in its optimal condition to obtain best efficiency, so as to minimize the power cost of the user.

The UPS shall use redundant protection circuitry to protect the inverter. A robust snubber is added to suppress the spikes and noise, oversized, semiconductor fuses are provided, and ventilation is maximized. The result of this design is a more rugged, reliable and high efficient inverter. At the same time, the inverter can sustain overload and high peak current drawn by the load. Additionally, a longer MTBF is achieved.

2.6.3 Static Switch

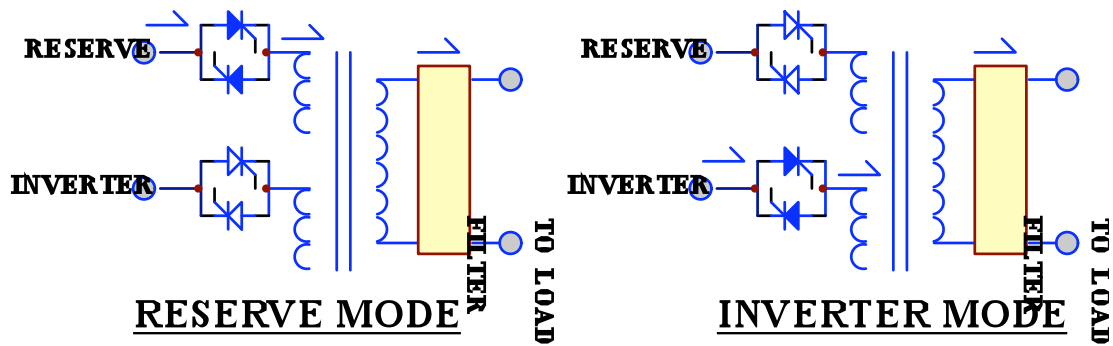

The static switch is composed of two pairs of SCRs, connected back-to-back. The switch can transfer the load from reserve to inverter or from inverter to reserve without losing power at the output. Therefore, it is a very important portion of a UPS.

Detection circuitry is added to the control circuit to achieve zero dead time transfer. Extra detection logic is employed to control when the static switch should transfer. For example, when output is short circuited, under normal mode operation, the UPS detects the short circuit and stops the inverter. The static switch will not transfer power to the reserve circuit, which might damage the reserve breaker. In case of an overload, the UPS will stop the inverter after a period the inverter can endure, and then transfer the load to the reserve circuit, since the overload capability of the static switch is higher than the inverter.

The transfer action is determined according to the reserve-input voltage and frequency to protect supplying incorrect power to the load. Finally, there is a double check by the CPU as to whether the transfer is successful or not.

2.6.4 Maintenance Bypass

The Maintenance Bypass Switch shall use 3 circuit breaker scheme:

Rectifier

Reserve

By-pass

The maintenance bypass switch is already installed inside the UPS for convenience and It should be open under normal operation, and only closed during maintenance. All power supplies inside the UPS should be disconnected before touching any parts inside the UPS. Thus, the maintenance bypass switch is a necessity to maintain AC power at the output and yet keep maintenance personnel safe at the same time. If the bypass breaker is closed under normal operation, the inverter will stop and the load will be automatically transferred to reserve to prevent the inverter connecting directly to the AC source. Of course, you cannot switch on the inverter as long as the maintenance bypass breaker is closed.

NOTE:

To properly use the maintenance bypass breaker, switch off the inverter first. The static switch will automatically transfer the load to reserve without dead time. Then one can close the maintenance bypass breaker, and then open the reserve breaker, so that the load gets power from the output without interruption.

2.7 System Diagnostics/Alarm

2.7.1 Front Panel

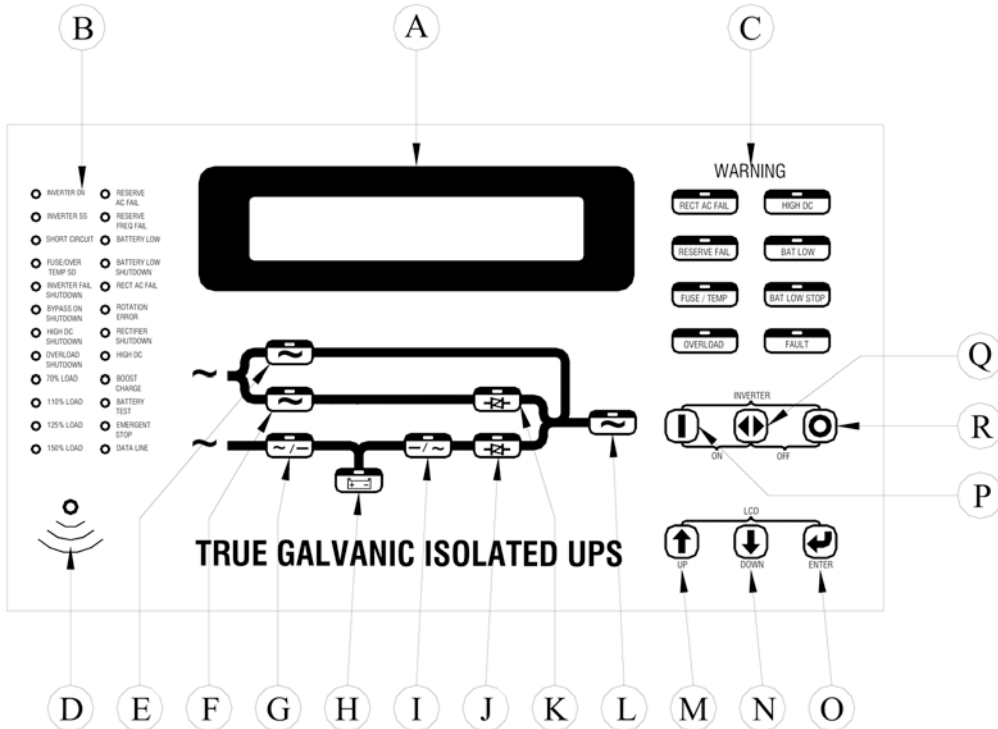

The front panel is located at the front of the PCB holder. It gathers the real time information of the UPS and shows them clearly to the user. It also provides switches for controlling and setting the UPS. Through this panel, the UPS can be not only a stand alone machine supplying the load, but also closely monitored by the user. Each part of the panel is explained below.

A:

LCD display: Real time status, data or historical events are displayed on the LCD. The UPS parameters, real time clock, inverter, and buzzer also can be set through this LCD. The LCD is back-lighted by LEDs to provide a sharp display. In order to lengthen the LED's life time, the LED are automatically shut off 3 minutes after no key is activated, but will light up again when one of the up/down/enter key is pushed.

B:

Status LEDs: 24 LEDs, representing all of the important information of the UPS, provide the most up to date information to the user. Therefore these LEDs are especially important when abnormal conditions occur. The 24 information items are as shown below:

INVERTER ON – inverter is running.

INVERTER SS – inverter static switch conducts while the reserve static switch is opened.

SHORT CIRCUIT – UPS output is in short circuit state.

FUSE/OVER TEMP SD – inverter shutdown due to either fuse broken or over temperature condition.

INVERTER FAIL SHUTDOWN – inverter shutdown due to inverter output voltage too low.

BYPASS ON SHUTDOWN – inverter shutdown due to bypass breaker being closed while the inverter is running.

HIGH DC SHUTDOWN – inverter shutdown due to overly high DC bus voltage condition while the inverter is running.

OVERLOAD SHUTDOWN – inverter shutdown due to overload of the inverter for a period over that which the inverter can endure; will restart 7 seconds after overload removed.

70% LOAD – load connected to the output is at or over 70% of the UPS rating.

110% LOAD – load connected to the output is over 110% of the UPS rating.

125% LOAD – load connected to the output is over 125% of the UPS rating.

150% LOAD – load connected to the output is over 150% of the UPS rating.

RESERVE AC FAIL – reserve AC magnitude is out of range.

RESERVE FREQ FAIL – reserve frequency is out of range.

BATTERY LOW – DC bus (or battery) is lower than 320VDC, low battery shutdown is approaching.

BATTERY LOW SHUTDOWN – inverter shutdown due to DC bus (or battery) lower than 295VDC (lower than the acceptable DC voltage of the inverter).

RECT AC FAIL – rectifier AC magnitude is out of range.

ROTATION ERROR – rectifier AC phase rotation is incorrect.

RECTIFIER SHUTDOWN – rectifier shutdown due to DC bus too high (over 445VDC), will automatically restart 30 seconds after abnormal situation has been cleared.

HIGH DC – DC voltage over 430VDC and the bus voltage will be limited at this voltage.

BOOST CHARGE – the batteries are being boost charged by the rectifier.

BATTERY TEST – batteries are being tested.

EMERGENCY STOP – inverter shutdown due to emergency stop switch pushed.

DATA LINE – blinks when data is transmitted to or received from the communication port.

C:

Warning LEDs: When abnormal condition happens, these LEDs will light to warn the user according to the cause of the faulty condition. Therefore all these LEDs should be extinguished under normal condition. These LEDs are as shown below:

RECT AC FAIL – rectifier AC input is abnormal either due to AC magnitude out of the range or phase rotation error, rectifier shutdown.

RESERVE FAIL – reserve AC input is abnormal either due to AC magnitude out of range or frequency out of range.

FUSE/TEMP – Inverter fuse is blown or over temperature condition exists.

OVERLOAD – output is overloaded by over 110%, 125% or 150%.

HIGH DC – the LED will light as long as the DC voltage is over 430VDC.

BAT LOW – the LED will light as long as the DC voltage is lower than 320VDC.

BAT LOW STOP – the LED will light as long as the DC voltage is lower than 295VDC, inverter cannot start.

FAULT – the inverter is shutdown due to abnormal conditions such as overload, short circuit, high DC, fuse over temperature, bypass breaker on or emergency stop.

Since these LEDs are located behind the transparent window, the user can see them clearly without opening the door.

D:

Audible (buzzer) alarm: The user should not be expected to watch the UPS all the time. Therefore, when abnormal conditions occur, an audible sound should be emitted to warn the user to check the status of the UPS. The alarm buzzer will beep under any one of the following conditions:

INVERTER IS OVERLOADED-

>110%, beep once / 3 seconds

>125%, beep once / second

>150%, beep twice / second

BACK- UP

>320VDC, beep once / 3 seconds

<320VDC, beep twice / second

<295VDC, no beeping

INVERTER IS SHORT CIRCUITED - beep continuously

FUSE BROKEN - beep continuously

HEAT SINK OVER TEMPERATURE - beep continuously

HIGH DC SHUTDOWN - beep continuously

BYPASS ON STOP - beep continuously

E:

Bypass LED: This LED will light when the maintenance bypass breaker is closed. When the maintenance bypass breaker is closed, the inverter cannot be switched on and will stop immediately even when inverter is already running.

F:

Reserve LED: This LED will light when the reserve breaker is closed, and there is AC power supply present at the reserve terminal.

G:

Rectifier LED: This LED will light when the rectifier is operating normally, meaning the rectifier Mains are within the range specified, the rotation sequence of three phases is correct, the rectifier breaker is closed, and no high DC voltage is on the bus.

H:

Back-up LED: This LED will light when the UPS is in back-up mode. This is also as the indicator for battery test result. If the battery test does not pass, this LED will flash even if the UPS is not in back-up mode, to prompt the user to change the batteries.

I:

Inverter LED: This LED will light when the inverter is switched on, indicating whether the inverter is running or not.

J:

Inverter SS LED: This LED will light when the inverter static switch is turned on and the reserve static switch is turned off, i.e., the load is supplied from the inverter. Usually this LED will light 7 seconds after the inverter is switched on.

K:

Reserve SS LED: This LED will light when the reserve static switch is turned on and the inverter static switch is turned off, i.e., the load is supplied from the reserve. Since the reserve static switch and inverter static switch will never both turn on simultaneously, the Inverter SS LED and the Reserve SS LED should never both be lit simultaneously.

L:

Output LED: This LED will light when there is AC power present at the output terminal. This is an important indication to the user as to whether AC is available at the output or not.

M:

Up key: This is a LCD control key. It is for moving the cursor one item upward when items are being selected or for changing the number/character forward when data or parameter of the UPS is being set.

N:

Down key: This is a LCD control key. It is for moving the cursor one item downward when items are being selected or for changing the number/character backward when data or parameter of the UPS is being set.

O:

Enter key: This is a LCD control key. It is for changing backward to the previous page and also for confirming the number/character /item is selected.

P:

Inverter on switch: This is an inverter control switch. When this key is pushed with the control key simultaneously, the inverter will be switched on.

Q:

Inverter control switch: This is an inverter control switch. When this key is pushed with the inverter on key simultaneously, the inverter will be switched on. Similarly, when this key is pushed with the inverter off key simultaneously, the inverter will be switched off. Thus, this key is a guard for mistaken key strokes.

R:

Inverter off switch: This is an inverter control switch. When this key is pushed with the control key simultaneously, the inverter will be switched off.

2.7.2 Communication:

All interfaces are connected from 3R PCB. See the figure below.

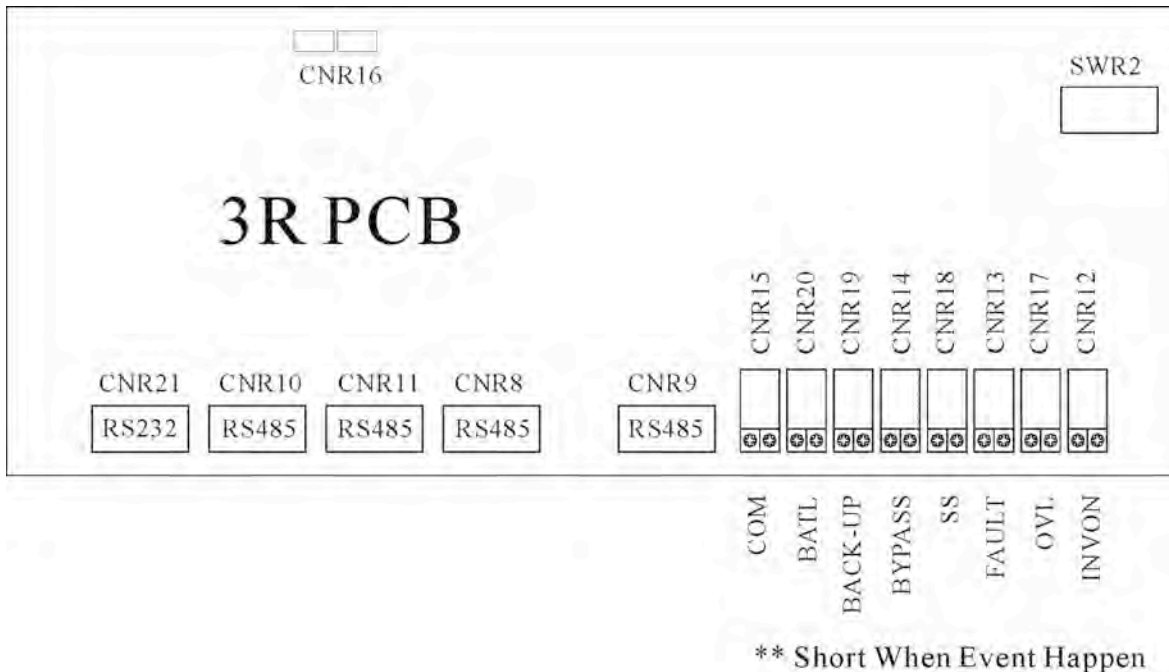

2.7.2.1 Dry Contacts

8 terminals of dry contacts are provided. These terminals are normally open (non-conducting). When an event occurs, the terminal will close (conduct). Maximum contact rating is 16A/250VAC (16A/30VDC). The events are shown below.

INVON – Closed whenever the inverter is on, open when the inverter is off.

OVL – Closed whenever the UPS is overloaded.

FAULT – Closed when the UPS encounters a fault condition, such as high DC shutdown, short circuit, fuse/over-heat, overload shutdown, emergency stop, inverter abnormal, bypass on shutdown. The contact is latched until manual reset (off switch) or 30 seconds after the fault condition is removed.

SS – Closed when the inverter static switch is conducting, open when the reserve static switch is conducting (The two static switches will never conduct simultaneously).

BYPASS – Closed when the maintenance bypass breaker is closed, open when the breaker is opened.

BACK-UP – Closed when the inverter (running) is being backed up by the battery.

BATL – Closed when the inverter is using battery power and the batteries are about to be exhausted.

COM –This contact can be configured as the OR result of the signals described above. SWR2-1 (dip-switch pin 1) ~ SWR2-7 (dip-switch pin 7) can select one of the seven signals described above and SWR2-8 is the COM enable switch. Please refer to the dip-switch of SWR2 on the 3R PCB and the following examples and diagram.

Example 1:

If two contacts for BACK-UP are required. Switch on SWR2-6 & SWR2-8, and then both CNR19 & CNR15 will close when the unit goes to back-up.

Example 2:

If one contact for OVL & FAULT is required. Switch on SWR2-2 & SWR2-3, and then the CNR15 will close when either OVL or FAULT condition happens. Of course CNR17 will close when OVL happens and CNR13 will close when FAULT happens.

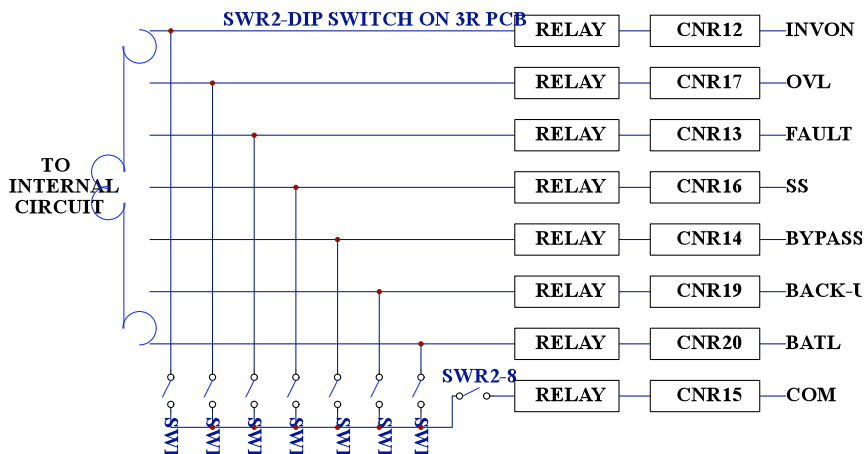

2.7.2.2 DB9 Connection

Four RS-485 and one RS-232 are provided to communicate with more sophisticated (option) modules. Each connector is especially dedicated to one type of external module. The following are some connection examples of optional modules.

CNR21 (RS-232) ⇔ UPSCOM- Software for PC Monitoring, SNMP Card

CNR9 (RS-485) ⇔ DCMAN- Battery Monitoring Module

CNR10 (RS-485) ⇔ UPSCAN- Remote Control Panel

CNR12,13,14,15,17,18,19 (RS-485) ⇔ UPSCALL- Auto Dialing Module

CNR11 ⇔ for transferring RS-485 into RS-232.

2.8 Operation Mode

2.8.1 General Topology

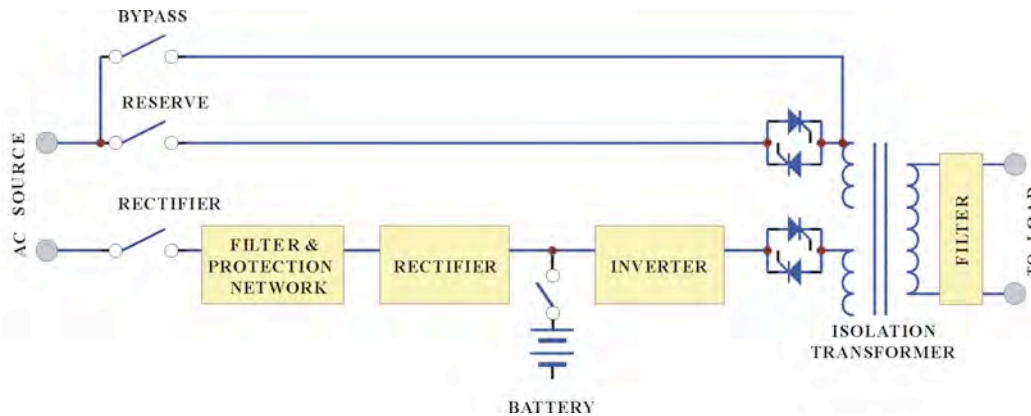

The UPS system is composed of input breakers, input filter & protection network, rectifier, battery bank, inverter, static switch, bypass breaker, isolation transformer and output filter. The basic topology is shown in the diagram above. Under normal AC mode, energy from the AC source is converted to DC power and supplied to the inverter to charge the batteries to its full capacity all the time, ready to support the output load in case of AC source failure.

Although the principle and operation of a UPS seems simple and straightforward, the requirement for a reliable and intelligent UPS makes the design and manufacturing of a high power UPS one requiring advanced technology, intelligence, experience and most important, consideration of the user interface. Many years have been spent in designing the most rugged, intelligent and reliable UPS for the market, and a safe and convenient UPS for the user.

Choosing the best and most suitable UPS for a given application can be easy or difficult, depending on the client's knowledge of key parameters. The most obvious specification, output power, depends on the size of the load. Often, an allowance of 50% more power is added to the present load requirement, both for tolerance and for future expansion.

Another important issue is reliability. The prime aim of a UPS is to protect your load. Therefore, the UPS should be much more reliable than the AC source. An unreliable UPS may suffer the problem of frequent break down, even more frequent than AC failure, and the cost of repair may become more than the cost of the unit itself.

Generally, there are four different modes of operation, the NORMAL OPERATION MODE, the BACK-UP (BATTERY) MODE, the RESERVE MODE and the MAINTENANCE BYPASS MODE. These are explained below.

2.8.2 Normal Operation Mode:

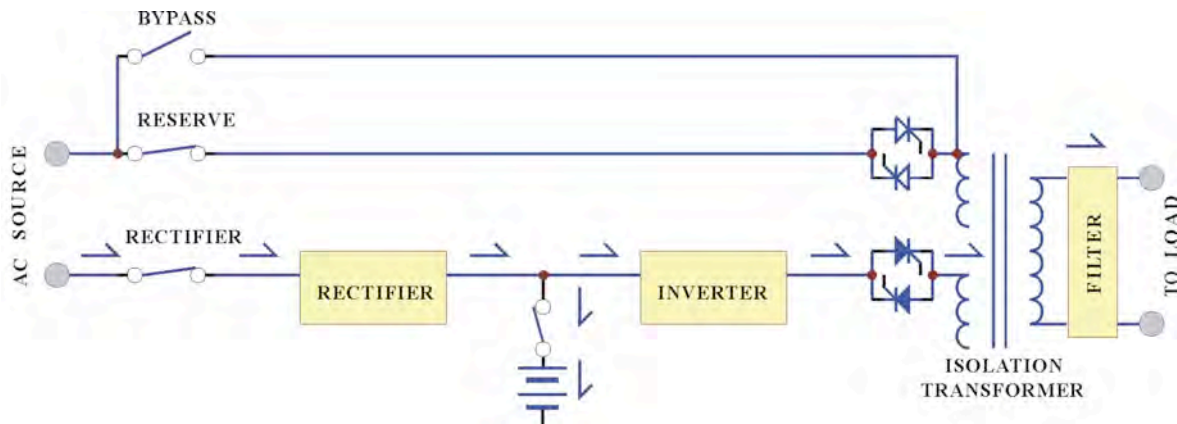

The rectifier converts the AC input to DC power to supply the inverter and charge the batteries simultaneously. All the fluctuations, surges and spikes of the AC input are removed during AC to DC conversion. Therefore, the AC supplied by the inverter is clean and stable.

2.8.3 Back-up Mode:

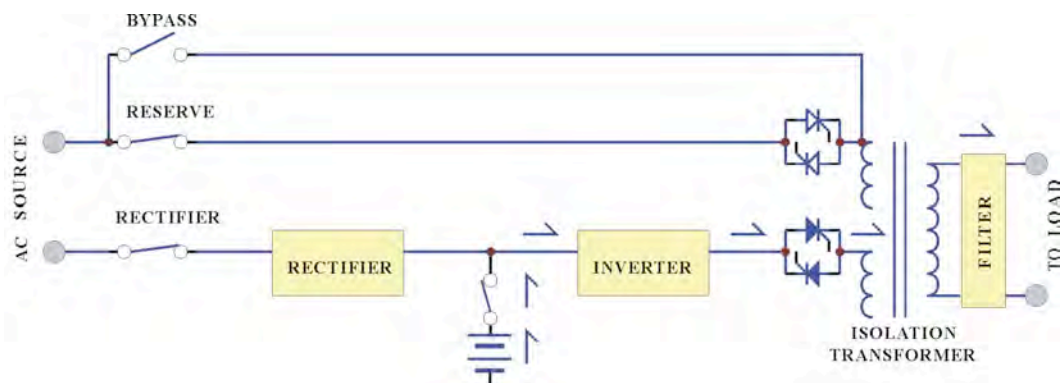

Since the batteries are connected directly to the DC bus, when the AC fails, the batteries change immediately from receiver to donor, supplying energy to the inverter instead of receiving energy from the rectifier. The output AC is not interrupted. Therefore, the load connected to the output is protected.

2.8.4 Reserve Mode:

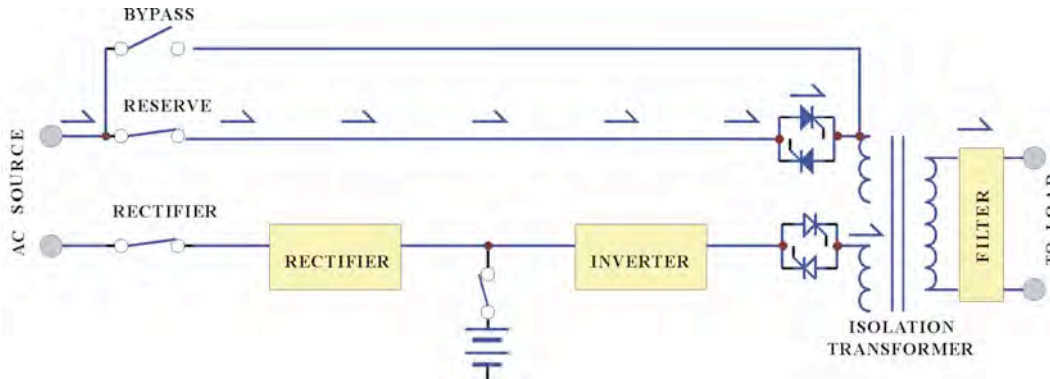

When the inverter is in an abnormal condition, such as over temperature, short circuit, abnormal output voltage or overloaded for a period exceeding the inverter's limit, the inverter will automatically shut down in order to protect itself from damage. If the utility power is normal, the static switch shall transfer the load to the reserve source without interruption of AC output.

2.8.5 Maintenance Bypass Mode:

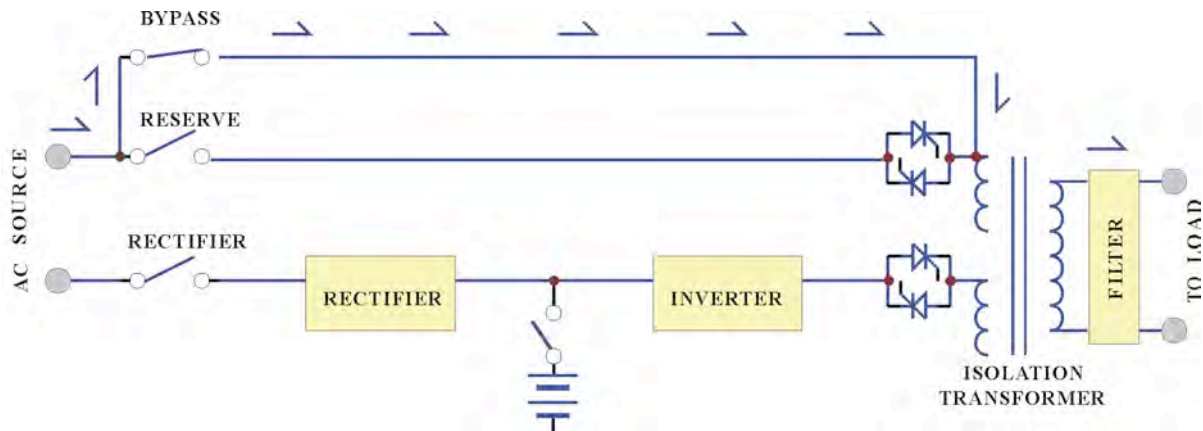

In case of UPS maintenance or battery replacement, and where the load cannot be interrupted, the user can turn off the inverter, close the bypass breaker and then open the rectifier and reserve breakers. The AC output will not be interrupted during manual bypass transfer procedure. Therefore, the maintenance bypass switch keeps continuously supplying power to the load. Electricity will not exist in UPS except the output transformer, thus ensuring the safety of service personnel.

Generally, the UPS is expected to run 24 Hours a day in normal operation mode once it is installed, except when the utility power fails, under overload conditions, or during maintenance.

Normal operation with batteries connected provides clean, stable, regulated and uninterrupted power to the load, free from any spikes and surges. Therefore, the UPS can be regarded as a perfect AC power source, limited in back-up time, under mains failure, only by the capacity of the batteries.

2.9 Options

2.9.1 Software for PC Monitoring – UPSCOM™

UPSCOM™ is a hardware/software combination installed on a PC to monitor multiple UPSs with DB9 connection in series. The connector on the UPS's side is RS-485 (for long distance transmission); therefore an RS-485 ↔ RS-232 adapter (hardware) is required to modify the signal. The software and hardware together form a package called UPSCOM™. See the UPSCOM™ specification for further information.

2.9.2 Auto Dialing Module – UPSCALL™

In case abnormal situations occur, UPSCALL™ will automatically dial specified phone numbers to inform management to take prompt action. The module, with built-in 23A12V battery, consumes power only when in the process of dialing so as to be operated under AC source failure. Furthermore, with functions of multiple phone number setting and dialing, UPSCALL™ has no need of dedicated lines, and can offer user a prompt and convenient way for monitoring the UPS. See the UPSCALL™ specification for further information.

2.9.3 Battery Monitoring

Battery Monitoring system is available, consult factory for this option.

2.9.4 External Output Auxiliary CBs

External output Panel Boards with 3 phase main Circuit breaker is available in external enclosure to the UPS.

2.9.5 1 pole, 20 amp circuit Circuit Breakers up to 18

2.9.6 Normally OFF output Auxiliary CBs (1 pole, 20 amp circuit Circuit Breakers up to 18).

2.9.7 Earthquake Protection: The cabinet can be evaluated for earthquake compliancy considering installation, location or additional seismic brackets as an option.

2.10 Mechanical Design and Construction

2.10.1 Enclosure: All system components shall be housed in a single floor mounted small footprint, freestanding NEMA 1 enclosure. The cabinet should have front access only with two doors and the depth of no more than 31.5 inch (up to 320kva only), allowing easy component reach from the front. The enclosure shall have modular design for clear and accessible layout. Cabinet doors shall require a key for gaining access. Front access only shall be required for safety and expedient servicing, adjustments and installation. The cabinets shall be structurally adequate and have provisions for hoisting, jacking and forklift handling.

2.10.2 Construction: Only quality, unused material shall be used to build the unit, under strict observance of standards and quality workmanship. The cabinets shall be cleaned, primed and painted IBM pearl or equivalent. The unit shall be constructed with rigorously tested, burned-in, replaceable subassemblies. Only two electronic subassemblies: heat sink assembly with IGBTs and drivers and control PCBA shall be used for maximum reliability and simple servicing. All printed circuit assemblies shall have plug connections. Like assemblies and like components shall be interchangeable.

2.11 Replacement Parts:

Parts shall be available through an extensive network to ensure around-the-clock parts availability throughout the country. Customer Support Parts Coordinators shall be on-call 24hrs/day, 7days/week, 365 days a year for immediate parts dispatch. Parts shall be delivered to the site within 24 hours.

2.12 Maintenance Training:

In addition to the basic operator training conducted as a part of the system start-up, classroom courses for customer employees shall be made available by the manufacturer. The course shall cover Inverter theory, location of subassemblies, safety, battery considerations and Inverter operational procedures. It shall include AC/DC and DC/AC conversion techniques as well as control and metering, Troubleshooting and fault isolation using alarm information and internal self-diagnostics interpretation shall be stressed.

2.13 Maintenance Contracts:

A comprehensive offering of preventive and full service maintenance contracts shall be available. An extended warranty and preventive maintenance package shall be available. All services shall be performed by factory trained Service Engineers.

2.14 Site Testing:

The manufacturer's field service personnel shall provide site testing if requested. The testing shall consist of a complete test of the Inverter system and the associated accessories supplied by the manufacturer. A partial battery discharge test shall be provided as part of the standard start-up procedure. The test results shall be documented, signed, and dated for future reference.

NOTE: This Guide Specification follows the Construction Specification Institute guidelines per CSI MP-2-1,MP-2-2. It is subject to change due to product improvement and/or enhancement.

Please use this document as a guide specification, and do not hesitate to contact our application engineering department, should you have any further questions or special requirements.

You can contact us at: **800-786-6915**

2.15 WARRANTY

Inverter Module: The Inverter manufacturer shall warrant the Inverter against defects in materials and workmanship for a period of twenty-four (24) months. The warranty shall cover all parts and labor for one (1) year period beginning from the start up, or 18 months from the ship date, whichever comes first. Optional 1 year extended warranty and maintenance contract packages shall also be available at the end of the factory maintenance period.

2.16 Wiring Installation: Inverter cabinet conduit entry arrangement shall allow for flexibility of user wiring installation. The wiring shall be routed thru the top or either side of the cabinet.

2.17 Wiring Termination: The Inverter input and output power connections shall be hard wired within the cabinet. Optional input line cable and output distribution panel shall be available (limited range of units only, please consult factory for details). Input and output terminal blocks shall be provided for easy field wiring of Inverter and battery cabinets.

2.18 Factory Startup:

Provides a factory service representative to perform the initial startup of the Central Lighting Inverter System.

2.19 Drawings and manuals:

Drawings and manuals supplied with each unit shall include: Complete set(s) of shop drawings showing physical dimensions, mounting information and wiring diagrams. Installation Manual(s) with complete instructions for locating, mounting, interconnection and wiring of the system. User Manual(s) outlining complete operating and preventive maintenance procedures.

2.20 Batteries shall be shipped separately

2.21 Installation:

The Central Lighting Inverter shall be installed in accordance with all appropriate manufacturers' installation instructions and in compliance with all appropriate codes.