

Device circuit breakers - the basics
Basic knowledge for
protection in the event of
overload and short circuit

Introduction

The increasing demand for high quality and efficiency in production is leading to the construction of increasingly complex systems. At the same time, the requirements for safety and availability are increasing because the failure of a machine or larger system parts can result in significant costs.

A well-planned safety concept for the individual circuits and terminal devices of the entire system makes a significant contribution toward operational reliability. This also includes the selection of a sufficiently strong power supply and suitable protective devices that safely protect against short circuit and overload currents. It is advantageous to provide fuse protection for each piece of equipment. Then, only those circuits affected by overload shut off.

Read this brochure to find out how protective devices work and which applications the various versions are suitable for.



Railway technology



Process technology



Automotive industry

Primary areas of application

Device circuit breakers are used everywhere in situations where loads must be precisely protected from overloads and short circuits. Unlike circuit breakers, which protect larger installation areas and the devices operating within from a specified maximum current, a quick, safe shutdown is the focus here.



Gas and oil industry



Machine building



Telecommunications technology

Due to the special performance requirements, device circuit breakers are to be found upstream of actuators in system and process controllers, and in building services management.

Here, a number of target industries are shown where devices are used that are protected with device circuit breakers.

Contents

1	Overload and short-circuit currents	4
2	The right protection for a circuit	5
3	Influence of cable lengths on shutdown behavior	6
4	Device circuit breakers	7
4.1	Selection criteria	7
4.2	Tripping characteristics	8
4.3	Internal resistance of protective devices	8
4.4	Parallel mounting of modular device circuit breakers	9
4.5	Main and auxiliary contacts	9
5	Electronic device circuit breakers	10
6	Electronic device circuit breakers, multi-channel	10
7	Electronic device circuit breakers, modular	12
8	Thermomagnetic device circuit breakers, modular	13
9	Common features of the CB device circuit breakers	16
10	Device circuit breaker board	17
11	Thermal device circuit breakers, modular	18
12	The right power supply	21
13	Redundant power supply	21
14	Standards	22
15	Additional information	22
16	Glossary	22

1 Overload and short-circuit currents

Overload currents and short-circuit currents are usually unexpected. They cause malfunctions and interruptions to the ongoing operation of a system. Production downtimes and repair costs are often the unpleasant consequences.

Effects of this type can be minimized by the separate protection of individual devices or with appropriately coordinated device groups. In this way, terminal devices are optimally protected against damage or destruction. System areas not in the affected circuit can continue to operate without interruption, whenever the overall process allows. This ensures high system availability.

The different nominal currents of the various loads illustrate the usefulness of separate protection for each individual circuit. Suitable device circuit breakers are available for every nominal current.

Overload currents

Overload currents occur if terminal devices unexpectedly require a higher current than the expected rated current. Such situations may arise, for example, due to a blocked drive. Temporary starting currents from machines are also considered to be overload currents. The occurrence of these currents can essentially be calculated, but can nonetheless vary depending upon the machine load at the moment it starts. When selecting suitable fuses or circuit breakers for such circuits, these conditions should be taken into account. A safe shutdown should be carried out in the seconds to lower minute range.

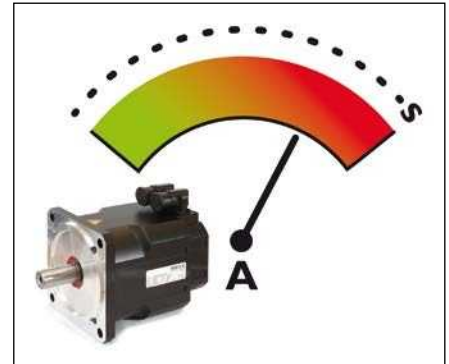

Shutdown of overload currents in the second to lower minute range

Short-circuit currents

Damage to the insulation between conductors carrying operating voltage can cause short circuits. Typical protective devices for shutting down short-circuit currents include fuses or miniature circuit breakers with various tripping mechanisms. Short-circuit currents should be shut down safely and reliably in the millisecond range.

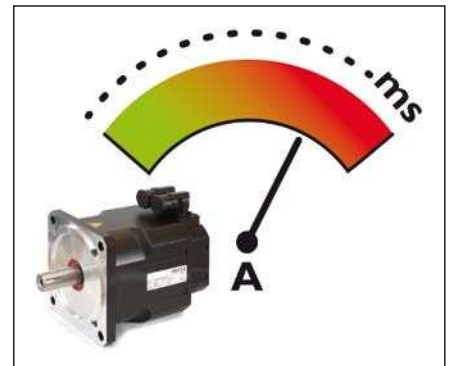

Shutdown of short-circuit currents in the millisecond range



Typical nominal currents of electrical loads

2 The right protection for a circuit

Selecting the right protective devices for protecting circuits and loads ensures the safe, optimized operation of electrical systems, even in the event of a fault.

When talking about circuit breakers, it is important to note the difference between power circuit breakers and device circuit breakers. Power circuit breakers are used in the field of power distribution. They mainly protect power cables in buildings or systems that supply terminal devices, building floors or building complexes with current. However, it is not the task of the circuit breaker to protect loads and terminal devices. It is only in the event of a short circuit in a terminal device that they switch off to protect the power supply line against an overload. They have a high switching capacity of 6 kA or more.

As the last protection level for terminal devices, thermomagnetic and electronic circuit breakers offer the most effective short circuit and overload protection. Securing the individual loads or small function groups when a device is disconnected prevents the simultaneous shutdown

of unaffected system parts in event of a fault. These areas can then continue working without interruption to the extent that the overall process allows.

If a circuit is reinstalled, you must ensure that appropriate protection for the provided terminal device is available. During installation, cable lengths and conductor cross-sections must also be taken into account. The cables must be designed for the expected operating current, but also so that they can deal with any potential overload and short-circuit currents. Within the scope of the graded protection of system areas, the selectivity between the individual fuses and protective devices must be maintained. This also ensures higher system availability as only the faulty circuit is switched off.

Device circuit breakers should be easily accessible when installed in control cabinets, so that they can be switched on again quickly, easily and without problems after tripping. Moreover, the ambient conditions of the installation should be taken into account. For example, a control cabinet should not be equipped with too many components, as this can cause an overload in the power

supply unit. Furthermore, a sufficient air flow and cooling process should be ensured. This prevents accidental activation due to overheating and the associated downtime.

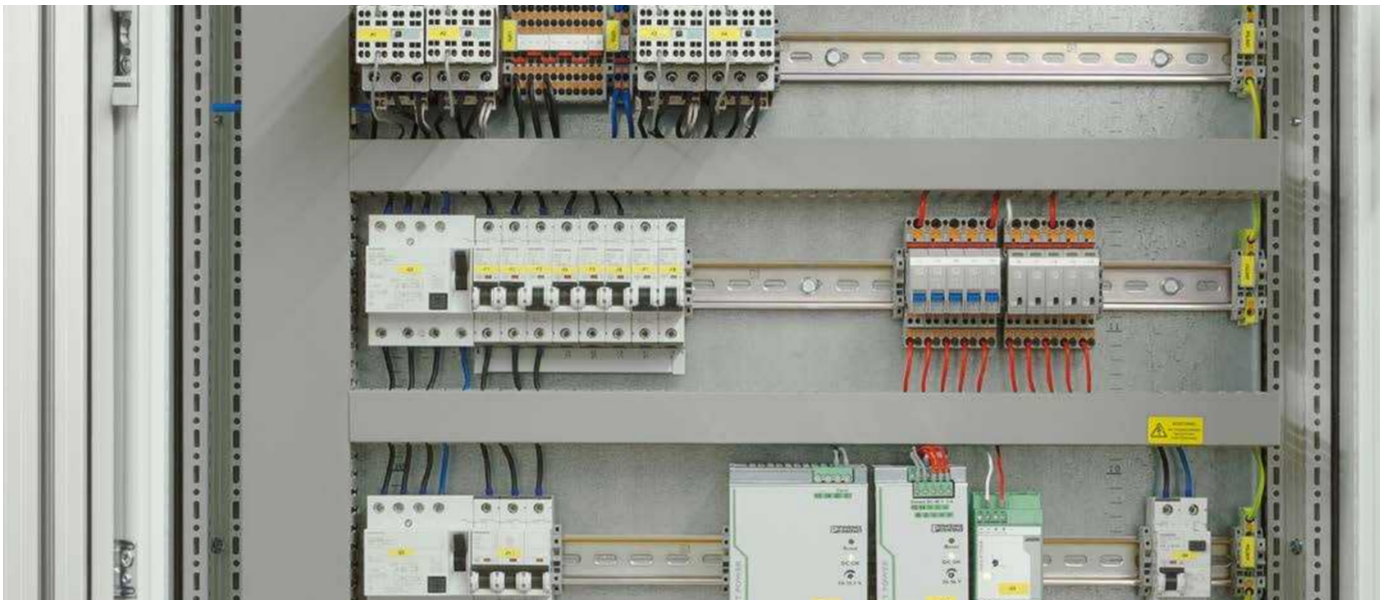

Professional installation for problem-free operation and easy maintenance

3 Influence of cable lengths on shutdown behavior

In the event of a fault, long cable paths limit the required tripping current. This can delay or even prevent shutdown of the safety device.

The maximum cable lengths that can be used between a power supply unit and a terminal device are defined by various criteria: This includes the maximum current for the power supply, the internal resistance of the circuit breaker and the cable resistance. The cable resistance depends on the cable length and conductor cross-section. For this reason, as a general rule, the shortest cable path should be selected during installation.

The cable resistance counteracts a short-circuit current. In the event of low voltage sources, a short-circuit current can be limited by the cable resistance in such a way that safety equipment no longer recognizes this current as short-circuit current. On circuit breakers with C characteristics, for example, the upper tripping limit is significantly higher than the nominal current. For this reason, a delayed shutdown is highly likely in the event of a short circuit when using this safety equipment.

The tripping characteristics of the circuit breakers with SFB characteristics as well as the electronic circuit breakers with active current limitation are optimized. These protective devices are more likely to detect that the nominal current has been exceeded rather than detecting

a short-circuit current. This prevents a dangerous overload of the affected equipment and functions as preventive fire protection simultaneously.

Cable calculations

In order for the protective device to switch off safely in the event of a short circuit or overload current, the maximum usable cable length should be calculated in case of doubt. The following data is necessary for the calculation:

R_{max}	Maximum total resistance
U	Nominal voltage
I_{CB}	Rated current of device circuit breakers
xl	Tripping factor in accordance with the current characteristic/nominal current multipliers
R_{Lmax}	Maximum cable resistance
R_{CB1A}	Internal resistance of 1 A device circuit breakers
L_{max}	Maximum cable length
A	Conductor cross-section
ρ	Specific cable resistance Rho, (Cu 0.01786)

Values for sample calculation:

U	= 24 V DC	
xl	= 15	> from the M1 characteristic curve
I_{CB}	= 1 A	
R_{CB1A}	= 1.1	> from the table Typical internal resistance, Chapter 4.3
ρ	= 0.01786	> copper
A	= 1.5 mm ²	> assumed

$$R_{max} = \frac{U}{I_{CB} \cdot xl} = \frac{24 \text{ V}}{1 \text{ A} \cdot 15} = 1,6 \Omega$$

$$R_{Lmax} = R_{max} - R_{CB1A} = 1,6 \Omega - 1,1 \Omega = 0,5 \Omega$$

$$L_{max} = \frac{R_{Lmax} \cdot A}{\rho} = \frac{0,5 \Omega \cdot 1,5 \text{ mm}^2}{0,01786 \frac{\Omega \cdot \text{mm}^2}{\text{m}}} = 42 \text{ m}$$

Calculation in three steps: 1. Total resistance of the circuit, 2. Maximum cable resistance, 3. Maximum cable length.

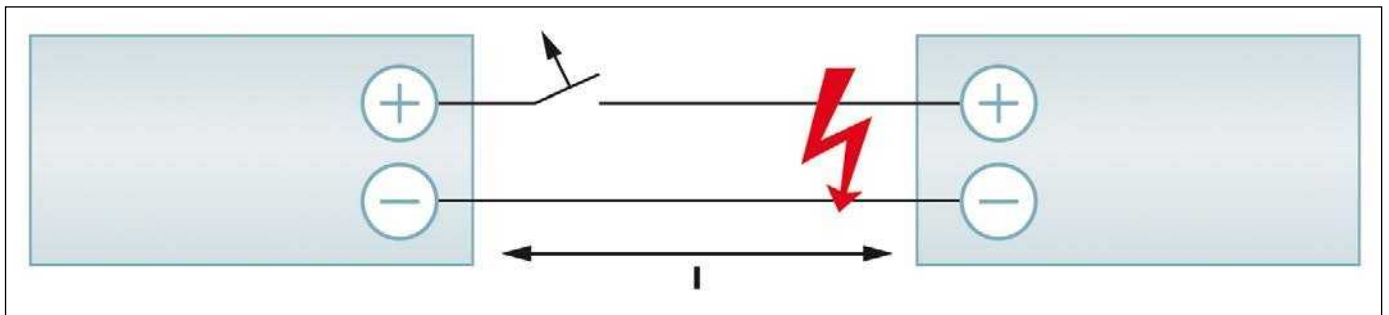

The length and the cross-section determine the cable resistance and, therefore, the switch-off conditions for a device circuit breaker

4 Device circuit breakers

The requirements for optimum device protection vary depending on the area of application and tasks. For this reason, various device circuit breakers that work with different technologies have been developed over time.

There are electronic, thermomagnetic and thermal device circuit breakers. The differences lie in the tripping technologies and shutdown behavior. Characteristic curves clearly illustrate the shutdown characteristics of the various device circuit breakers.



Product examples of various device circuit breakers

4.1 Selection criteria

Device circuit breakers are selected based on the nominal voltage, nominal current, and, if required, the starting current of a terminal device. In addition, the shutdown behavior of the device circuit breaker must correspond to the expected error situations. There are differences in error situations involving a short circuit and those involving an overload.

	Tripping time in the case of overload	Tripping time in the event of a short circuit	Your application is optimally protected for
Thermal circuit breakers			<ul style="list-style-type: none"> Overload
Thermo-magnetic circuit breakers			<ul style="list-style-type: none"> Overload Short circuit Long cable paths (SFB tripping characteristic)
Electronic circuit breakers			<ul style="list-style-type: none"> Overload Short circuit Long cable paths (active current limitation)

Shutdown behavior: Unsuitable Sufficient Ideal

Recommended selection according to shutdown behavior and error situation

4.2 Tripping characteristics

Tripping characteristics provide essential information for determining the suitability of a protective device for a particular application. They indicate the operating range of current-limiting protective devices in a current/time characteristic curve. The width or tolerance of the operating range depends on the type of protective device.

Conventional fuses with fuse wires are ranked among the oldest safety equipment. Even here there are various versions that are distinguished by the fuse wire length, the housing design or the type of cooling, such as air or sand. These features influence the operating range. In essence, the design and thickness of the fuse wire determine the nominal current for which the fuse is used.

Modern miniature circuit breakers and device circuit breakers, which we are currently discussing, can be developed with high precision for a particular tripping characteristic.

For device circuit breakers with thermal tripping in particular, the ambient temperature must be observed. The various circuit breakers respond in different ways to external temperature influences. A temperature factor must be taken into account when determining the correct shutdown time. This must be multiplied by the relevant current/time characteristic curve values. This results in the final value. Some typical values are shown in the table. As a standard condition, the ambient temperature is normally assumed to be 23 °C. For this

reason, the factor is 1. If the ambient temperature is lower, tripping is delayed. In this case, the factor is lower than 1. Higher temperatures ensure an earlier tripping process. In this case, the factor is above 1.

More information on characteristic curves can be found in the following chapters, where the specific characteristics and characteristic curves of various circuit breakers are described.

Ambient temperature °C	Temperature factor		
	Thermo-magnetic circuit breaker	Thermal miniature circuit breaker	Thermal circuit breaker
-20	0.79	0.82	0.76
-10	0.83	0.86	0.84
0	0.88	0.91	0.92
+23	1	1	1
+40	1.12	1.09	1.08
+60	1.35	1.25	1.24

Different temperature factors apply to the various circuit breakers, depending on the ambient temperature

4.3 Internal resistance of protective devices

The internal resistance of a protective device also has an influence on the characteristic curve. It is specified either as a resistance value in ohms or as a voltage drop over the internal resistance in millivolts.

In principle, you should try to achieve a very low internal resistance. The power dissipation in the circuit breaker then drops and it is better suited for use in circuits with low nominal voltage. However, in comparison, the tripping characteristic shifts slightly to the right. This results in a slightly delayed tripping time.

The following tables illustrate the typical voltage drop values and internal

resistance values of various device circuit breakers.

Nominal current A	Typical voltage drop mV	
	Electronic circuit breakers	Thermal miniature circuit breaker
1	140	
2	100	
3	120	
4	100	
5	130	< 150
...		< 150

Each of the various circuit breakers has a typical voltage drop over the internal resistance, depending on the nominal current

Nominal current A	Typical internal resistances Ω	
	Thermo-magnetic circuit breakers	Thermal circuit breakers
0.1		81
0.5	5	3.4
1	1.1	0.9
2	0.3	0.25
3	0.14	0.11
4	0.09	0.07
5	0.06	≤ 0.05
8	≤ 0.02	

Each of the circuit breakers has a typical internal resistance, depending on the nominal current

4.4 Parallel mounting of modular device circuit breakers

When mounting device circuit breakers in rows with a simultaneous current load, a reciprocal thermal effect occurs. This is comparable to a rise in the ambient temperature and results in the circuit breakers being switched off too quickly.

Influencing factors:

- Ambient temperature
- Nominal current under operating conditions
- Nominal current of circuit breakers
- Number of circuit breakers installed next to each other
- Distance between circuit breakers

A good universal corrective measure would be to size the circuit breakers so that they are only loaded with 80% of the circuit breaker's nominal current under normal operating conditions. This would compensate for temperature influences and optimize the shutdown behavior.

4.5 Main and auxiliary contacts

Many device circuit breakers have additional auxiliary contacts. This enables remote signaling of the main contact switching states and control of further functions that allow for remote interrogation and error messages.

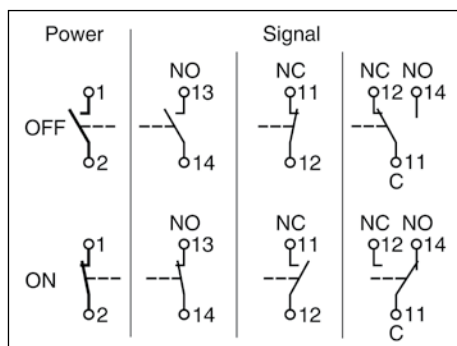

Position of the auxiliary contacts based on the switching state of the main contact

Power
Signal
NO normally open
NC normally closed
C common

main contact
auxiliary contacts
N/O contact
N/C contact
changeover foot contact
(common)

Marking the connections:

Main contacts

individual: 1-2
in groups: 1-2 / 3-4 / 5-6 / ...

Auxiliary contacts

individual N/O contacts: 13 - 14
N/O contacts in groups: 1.13-1.14 / 2.13-2.14 / 3.13-3.14 / ...

individual N/C contacts:

11 - 12

N/C contacts

in groups: 1.11-1.12 / 2.11-2.12 / 3.11-3.12 / ...

5 Electronic device circuit breakers

Electronic device circuit breakers are generally used in conjunction with 24 V DC switched-mode power supply units. They are frequently used in machine and ship building, systems manufacturing and automation technology. The active current limitation prevents the danger of a switched-mode power supply unit overload if an error occurs in a connected circuit. Therefore, the output voltage on the switched-mode power supply unit remains and all other circuits can continue to operate. These circuit breakers are ideal for protecting relays, programmable controllers, motors, sensors/actuators and valves, for example.

The combination of electronic device circuit breakers and a pulsed power supply increases the availability of systems and machines.

Function description

Electronic device circuit breakers from the CB and CBM product series feature active current limitation. This function limits the short circuit and overload currents to a value of 1.25 to 2 times the nominal current. This protects the power supply against currents which are too high and prevents a drop in output voltage

from the switched-mode power supply unit. Therefore, it is possible to almost completely plan the connected load of a DC voltage power supply. In addition, longer cable paths between the power supply and load are possible without negatively impacting the shutdown behavior.

The integrated sensor continuously measures the flowing current and switches within approximately 50 to 800 milliseconds in the case of an overload or short circuit. In contrast to thermal and thermomagnetic device circuit breakers, these protective devices switch electronically via a transistor.

Tripping characteristic

Even in the case of high cable resistance, electronic device circuit breakers trip in the event of a short circuit after a few milliseconds. In the event of an overload, the current is a maximum of 1.25 times the nominal current (as is the case with the CB product series).

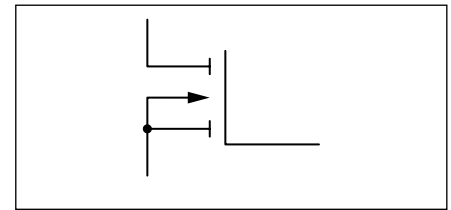

Circuit diagram

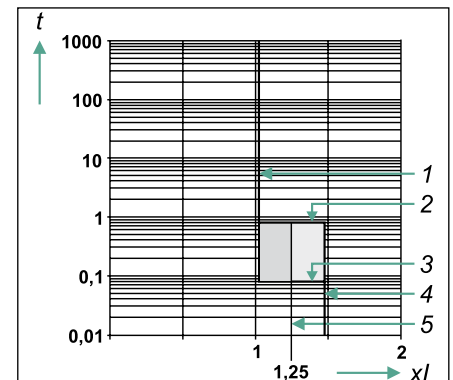

Typical characteristic curve of a CB-E electronic circuit breaker

t Switching time (in seconds)

xI Multiples of the nominal current/tripping factor

- 1 Tripping minimum is 1.05 x nominal current
- 2 Maximum shutdown time is 800 ms (depending on nominal current)
- 3 Minimum shutdown time is 80 ms (depending on nominal current)
- 4 Tripping maximum is 1.45 x nominal current
- 5 Current limitation with 1.25 x nominal current

6 Electronic device circuit breakers, multi-channel

These protective devices have four or eight channels. The integrated remote signaling concept enables monitoring from any location. Their large temperature range and high resistance to shocks and vibrations mean that they can be used in a wide array of applications. The overall width of the modules is a mere 41 mm and - together with screwless push-in connection technology - provides a space-saving, installation-friendly solution.

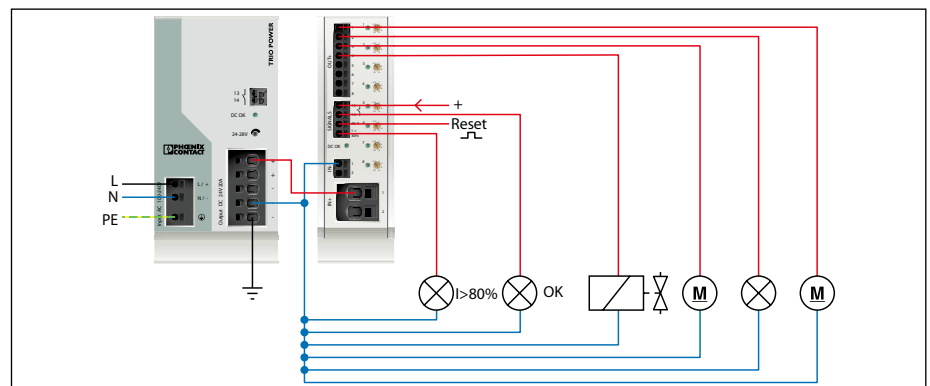

Application: multi-channel electronic device circuit breakers

Function description

The CBM product series protects against overload and short-circuit currents in 24 V DC circuits. The nominal current of the channels can be adjusted individually in small increments between 0.5 A and 10 A. The selected configurations can be locked electronically. This prevents danger resulting from incorrect settings.

Early warning system

The integrated early warning system decreases the number of failures. If 80% of the adjusted current of a channel is reached, a warning is indicated via the associated LED. The separate signal output can also be used for remote signaling.

Current limitation

Thanks to the integrated current limitation, the upstream power supply can be utilized optimally. This enables the use of smaller power supplies.

Shutdowns during surges and undervoltage

The protective device continuously measures the operating voltage. The tolerance range is defined at a minimum of 18 V and a maximum of 30 V. If the voltage is outside the tolerance range, then the protective device switches off. This prevents impermissible values on the terminal devices, thereby impeding malfunctions, unwanted system states and damage to the terminal devices.

Nominal current assistant

This mode enables optimal configuration of the fuse value with respect to the load current of the terminal device to be protected. First, the protective channel must be set to 10 A. Then the terminal device is switched on so that its typical load current starts flowing. The nominal current setting for the protective channel is gradually adjusted downward, starting at 10 A. If the flashing channel LED changes from green to yellowish green, 80% of the load current has been reached. Now, the setting is adjusted upward one level. The channel LED flashes green. When the LED key is pressed, this setting is applied. This concludes the optimal nominal current configuration for the terminal device.

- 4 or 8 independent channels, power out
Out+
- Remote indication contact
13-14
- Reset input
RST
- Early warning at 80%, output and LED signal
 $I < 80\%$
- LED signal for supply voltage / LED keys
DC OK
- Power supply 2 x minus, ground
IN -

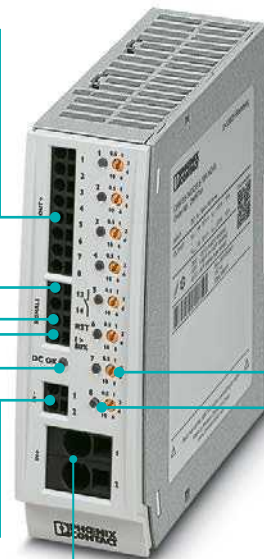

- Power supply 2 x plus, power in
IN +

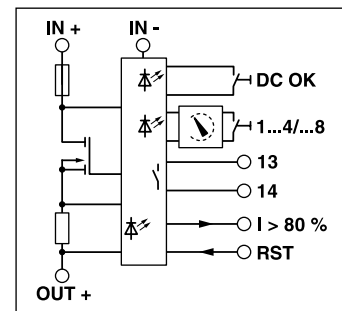

- Current selection switch, adjustable nominal currents 0.5-10 A
1 ... 4/... 8
- Electronic locking mechanism/ LED keys
1 ... 4/... 8

7 Electronic device circuit breakers, modular

The modular, electronic device circuit breakers of the CB product series are available in single-channel and two-channel versions. They are plug-in and can be quickly replaced for system changes. As a modular solution, they offer a high level of maintenance convenience and with an overall width of just 12.3 mm per channel, they save a lot of space.

Function description

These circuit breakers also operate with active current limitation. They also provide various options for the remote signaling of the function status. Versions with floating N/O contacts or N/C contacts, as well as versions with an active output signal, are available. The floating circuit breakers overlie the 11(a) and 14 (c) connections. The versions with an active output signal only require the 14 (c) connection. Therefore, the 11(a) connection can be used (optionally) as a reset or control input.

The CB E1 24DC/... S-R P product line features a reset input with a connection designation of 11(a). A circuit breaker switched off due to an overload can be switched on again remotely using this input. This eliminates the need for on-site maintenance, provided no ongoing fault has occurred.

The CB E1 24DC/... S-R P product line features a control input that also has a connection designation of 11(a). Using this input, the circuit breaker can be switched on and off remotely at any time.

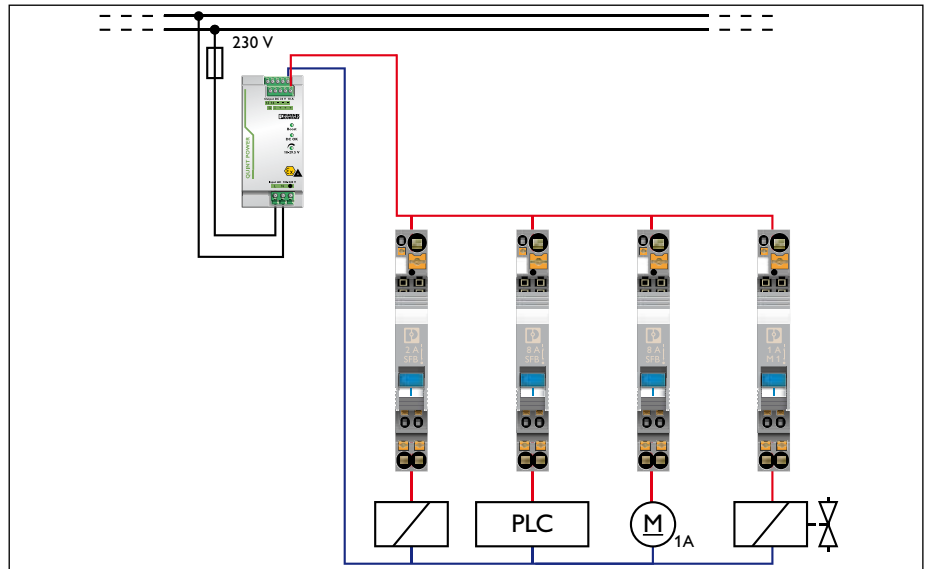

Application: CB-E electronic device circuit breakers

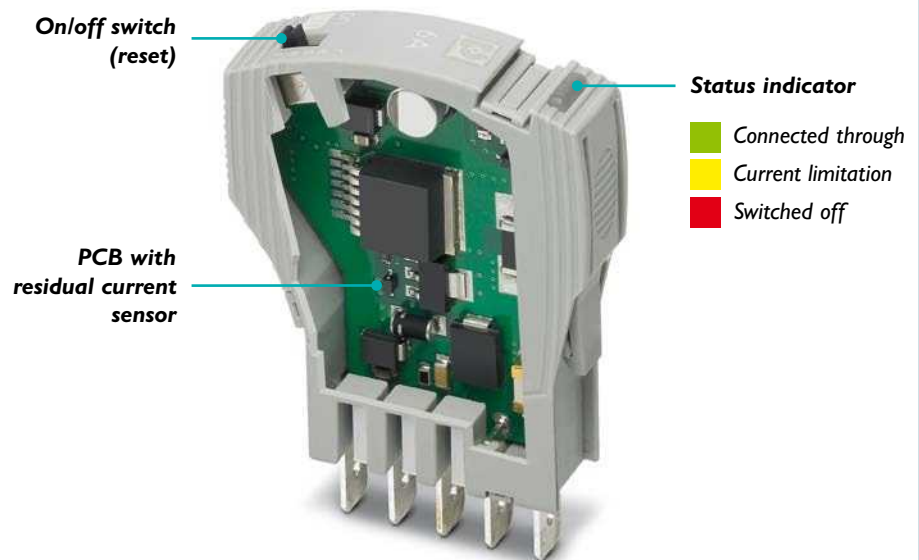

Design of CB-E electronic circuit breaker

Power	Status signal out 14 (c)	
	CB E1 24DC/...	...SI-R P
OFF	0	1 (24 V DC)
ON	1 (24 V DC)	0

The 14 (c) connection has either a high or a low output signal, depending on the product type and the position of the main switch.

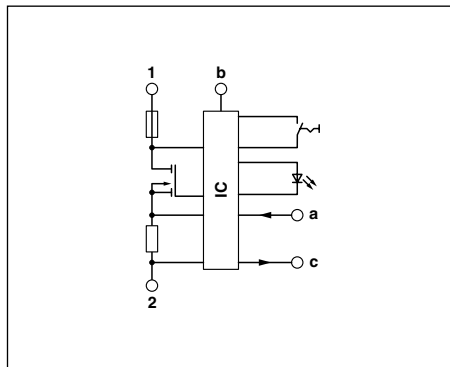

CB-E functional circuit diagram

- 1 Power in (line +)
- 2 Power out (load +)
- a Reset in or control in (depending on the type)
- b GND (ground)
- c Status out

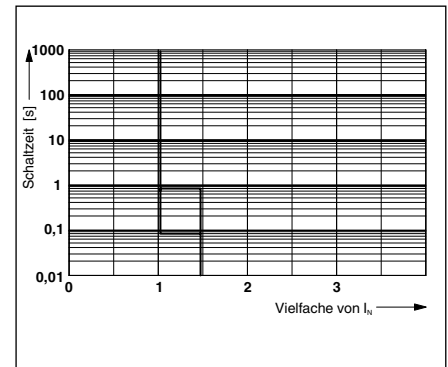

Tripping characteristic CB-E...

8 Thermomagnetic device circuit breakers, modular

Thermomagnetic device circuit breakers are used primarily in information and communication technology as well as process control. Due to various versions with different tripping characteristics, circuit breakers are ideally suited for protecting programmable logic controllers, valves, motors and frequency inverters. The reactivation and immediate remote signaling of the operating state ensure high availability.

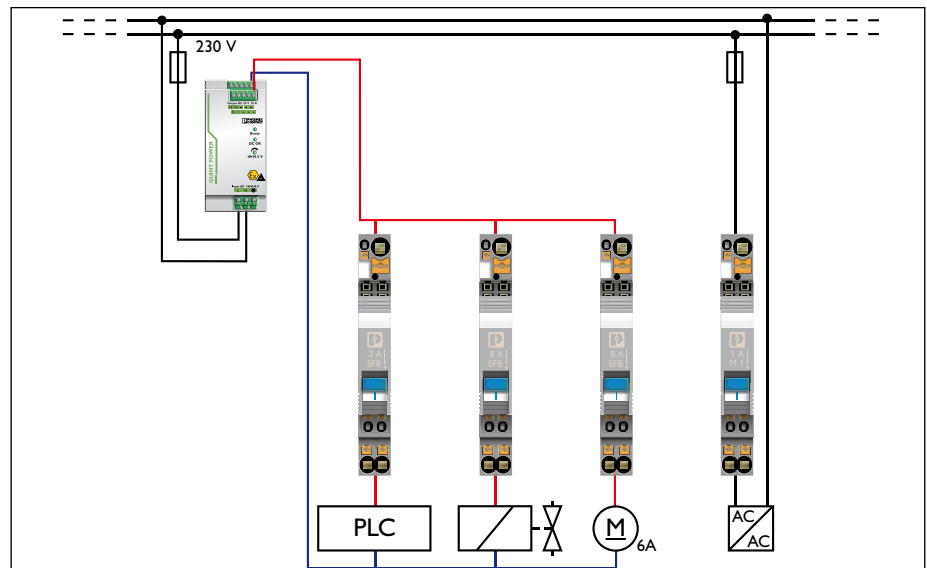

Application: Thermomagnetic device circuit breakers

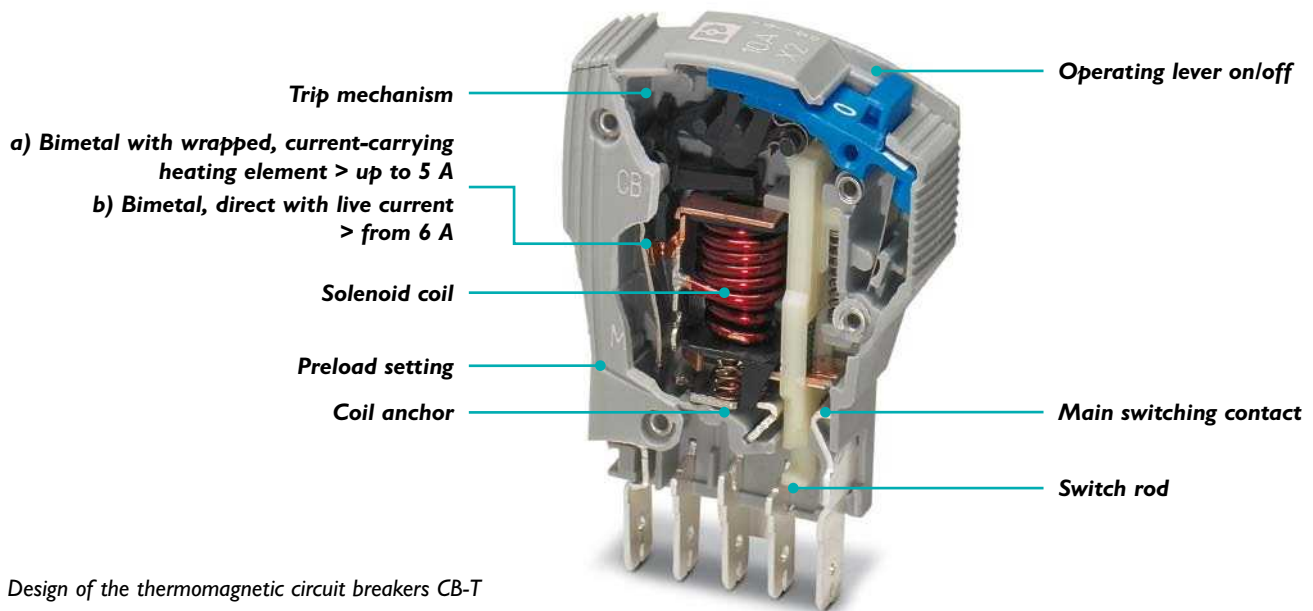

Design of the thermomagnetic circuit breakers CB-T

Function description

Thermomagnetic circuit breakers are equipped with two trip mechanisms. The temperature-dependent part of the mechanism consists of a bimetal with a heating coil. Currents that exceed the nominal current of the protective device generate heat in the heating coil. This causes the bimetal to bend and affect the switching mechanism. When the limit value is reached, the protective device shuts down. The devices respond to overload currents with a delay.

The magnetic trip mechanism is designed with a solenoid coil and a plunger or pivoted armature. Currents that exceed the nominal current of the protective device create a magnetic field in the coil. The current strengthens the magnetic field and attracts the armature. When the preset limit value is reached, the armature actuates the trip mechanism and shuts down the protective device. Within 3 to 5 milliseconds, it responds to the short-circuit currents and excessive overload currents.

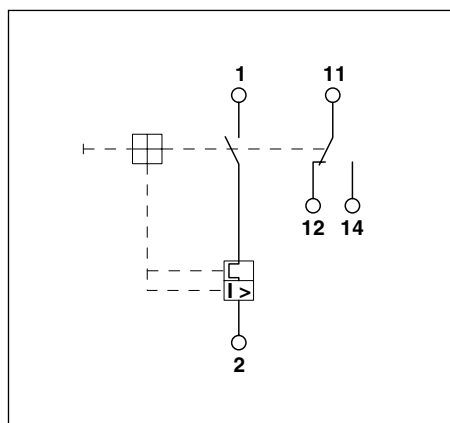

CB-E functional circuit diagram

- 1. Power in
- 2. Power out
- 11. Common
- 12. Normally closed (NC)
- 14. Normally open (NO)

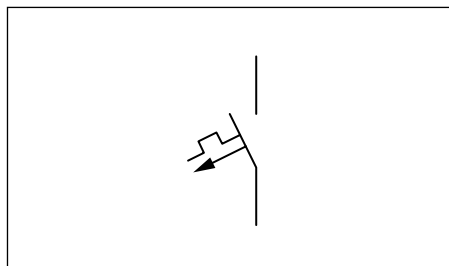

Circuit diagram

Tripping characteristics

Thermomagnetic device circuit breakers are generally available with three different characteristic curves. This allows all requirements to be met that result from various application cases.

The characteristic curve indicates that thermal trip [a] responds considerably later than the magnetic trip [b]. This can be explained by the required heating time of the temperature-dependant trip mechanism. However, even currents that are temporarily greater than the nominal current are identified as overload currents and shut down. The magnetic trip responds very quickly to fast rising currents that exceed the nominal current. This is particularly advantageous for detecting and shutting down short-circuit currents.

Alternating currents trip faster than DC currents with the same nominal value. This is depicted by the blue area in the curve. This is generally regarded as the behavior for all characteristic curves. Nevertheless, it is only used for circuit breakers with the M1

characteristic curve. Circuit breakers with the SFB or F1 characteristic curve trip just as fast with direct current, so that they would respond sensitively during operation with alternating current. With this in mind, the tripping ranges for alternating currents are not displayed in the SFB and F1 characteristic curves.

SFB characteristic curve

Circuit breakers with the SFB tripping characteristic offer maximum overcurrent protection – even in large systems with long cable paths. SFB stands for selective fuse breaking, i.e. selective shutdown.

Protective devices with this characteristic curve prevent an unnecessarily early switch-off in the event of brief current increases such as starting currents. They simultaneously prevent unnecessarily long, ongoing overload currents, which may lead to the hazardous generation of heat in operating equipment.

M1 characteristic curve

Circuit breakers with the M1 characteristic curve trip later than those with SFB or F1 characteristic curves. They withstand starting currents for longer periods but respond less swiftly to error situations. Drives blocked in error may be subjected to considerable damage

resulting from the associated overload current.

In comparison to the direct current characteristic curve, the alternating current characteristic curve on the axis of the nominal current multiple is drawn forward slightly. Even at a lower multiple of the nominal current, alternating currents cause the circuit breaker to trip.

F1 characteristic curve

Circuit breakers with the F1 characteristic curve trip quickly. They react very quickly to overload situations. However, this can lead to frequent, unnecessary shutdowns during operation. These circuit breakers are not suitable for protecting drives that generate temporary starting currents which exceed the nominal current.

Terminal devices that may become damaged by even short-term overloads and slight increases to the operating current are well protected by these circuit breakers.

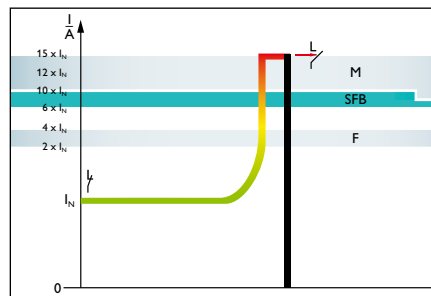

The maximum current that leads to shutdown of the circuit breaker depends on its characteristic curve

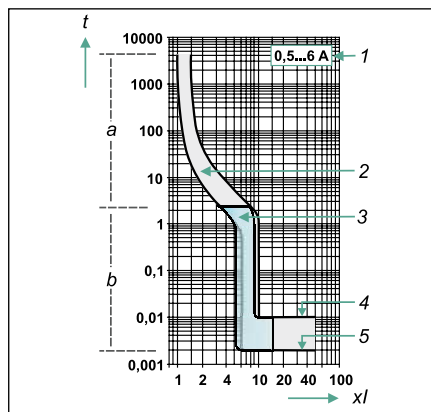

Typical tripping characteristic of a thermo-magnetic circuit breaker

- a Working range of the thermal trip
- b Working range of the magnetic trip
- t Switching time (in seconds)
- xI Multiples of the nominal current/tripping factor
- 1 Current range valid for the characteristic curve
- 2 DC tripping range (gray)
- 3 AC tripping range (blue)
- 4 Tripping maximum
- 5 Tripping minimum

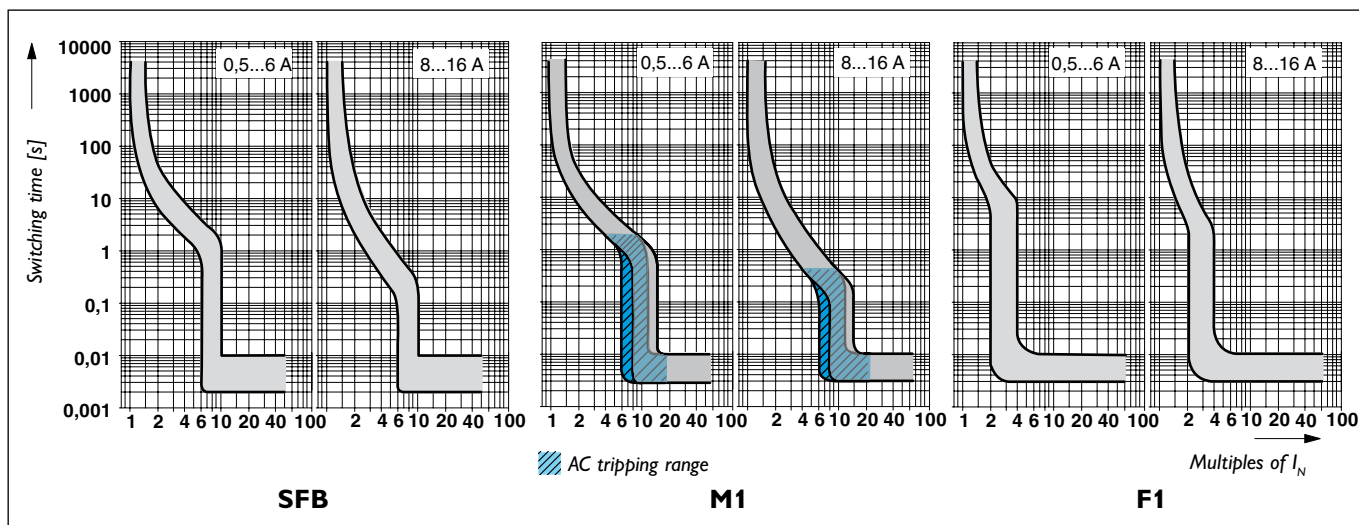

9 Common features of the CB device circuit breakers

The device circuit breakers of the CB product range feature a compact design with precise nominal current levels. Thermomagnetic and electronic device circuit breakers have a sophisticated remote signaling concept, which enables location-independent remote function monitoring.

These device circuit breakers are modular and plug-in. This enables circuits to be installed with base elements in advance. The circuit breakers required can be selected at a later date, and plugged into the pre-installed base elements. If changes to the system influence the nominal current of the protected circuits, a circuit breaker plug can be replaced without the need for any wiring to be involved.

The flexible installation concept of modular device circuit breakers offers unlimited potential applications. Their single-channel design enables various safety values to be combined across the entire available range.

The key system properties of the modular device circuit breakers



Nominal current levels from 0.5 A to 16 A

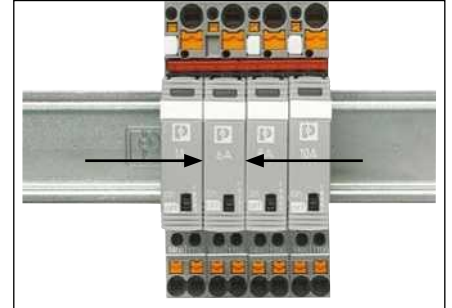

12.3 mm overall width

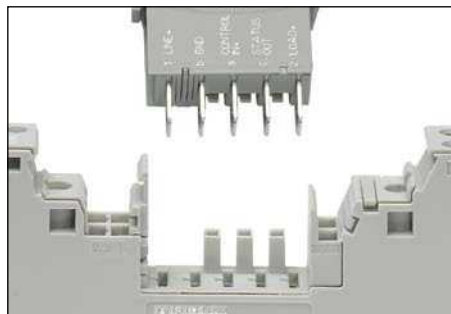

Two-piece/plug-in



Connector locking mechanism

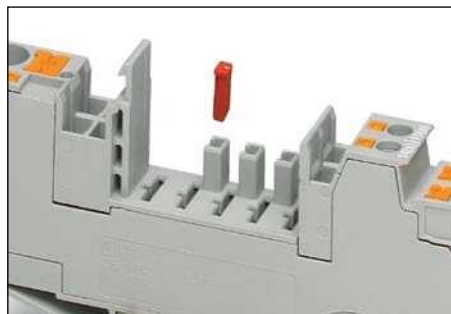

Coding between plug and base element

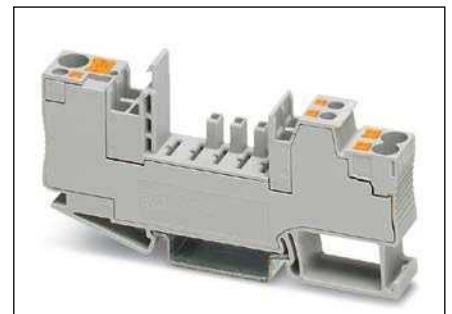

Variable connection technology push-in

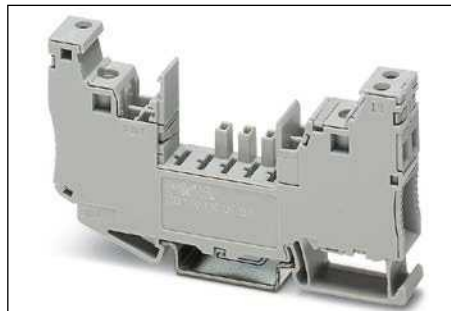

Variable connection technology, screw



Variable connection technology soldered base for printed-circuit boards

10 Device circuit breaker board

Each version of the device circuit breaker boards offers connection options for up to four loads per mode of protection. Therefore, the boards combine the advantages of the CB TM1... and CB E1... device circuit breaker series with easy, space-saving potential distribution. This also reduces the installation time. The switching states of the circuit breakers are monitored and provided as group remote signalling in two groups via connection terminal blocks. The two group remote signaling groups are switched in series by default.

The device circuit breaker boards are used in series production of machines or in control and process technology, for example. In the case of unchanged recurring applications, such pre-assembled multi-channel versions can be easily integrated into a system concept.

Each channel is equipped with a connection for safe shutdowns. This allows each channel to be shut down in case of danger. The two connections are linked via a jumper. The jumper can simply be disconnected when connecting a corresponding main switching contact.

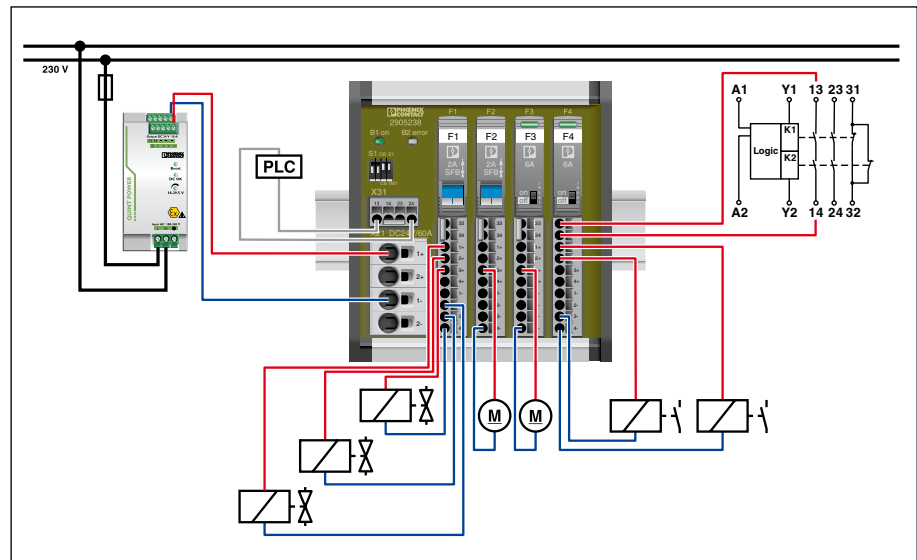

Application: Circuit breaker board with thermal and electronic device circuit breakers, using the four-channel version as an example. The contact of a safety relay is also connected for safe shutdowns

DIP switch for selecting the circuit breaker type for each mode of protection: electronic or thermomagnetic

Jumper for disconnecting the group remote signalling in two groups

Double terminal block for redundant power input via a redundancy module



Can be equipped with electronic, thermomagnetic circuit breakers from the CB product series and jumper plugs; 4, 8 or 12 slots, depending on the version

Jumpers per channel using the connections for a safety-oriented shutdown

Connection terminal blocks for up to four loads per mode of protection

The key features of the CBB device circuit breaker board

11 Thermal device circuit breakers, modular

Thermal device circuit breakers provide optimum protection against overloads for inductive and ohmic loads in power distribution systems, control cabinet engineering and systems manufacturing. They are resistant to high starting currents such as those which occur when starting a motor or switching on a transformer. They are also used for protecting circuits in battery and onboard systems. Thermal circuit breakers are suitable for maximum voltages up to 250 V AC or 65 V DC.

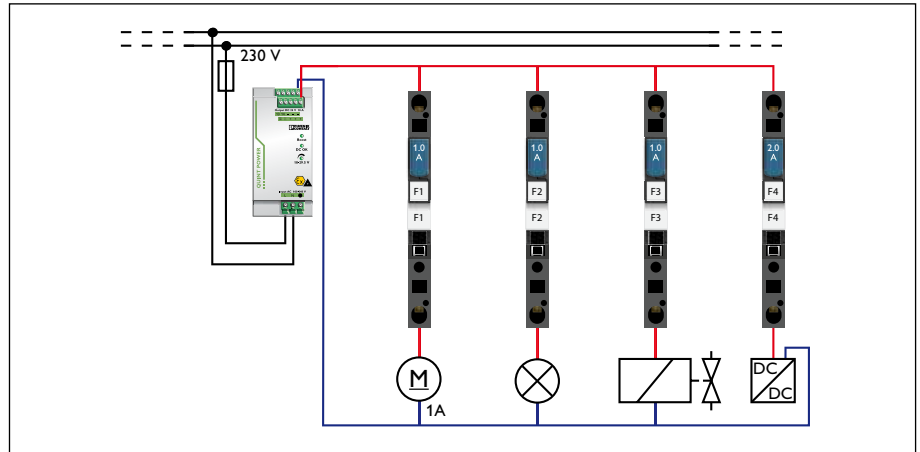

Application: thermal device circuit breakers

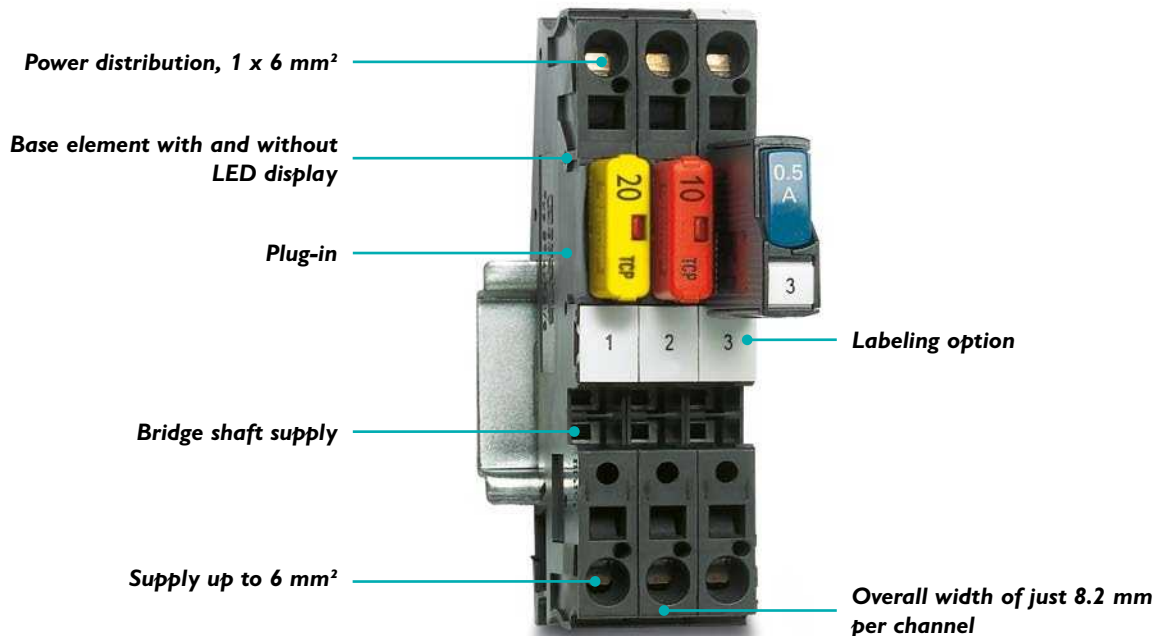

The key features of thermal device circuit breakers

Function description

The tripping element of thermal device circuit breakers is a thermal bimetal. It is a combination of bimetal and an electrical heating element. The bimetal consists of steel and zinc, which is deformed by heat. When a predefined heat level is reached as a result of an excessively high current in the heating element, the thermal bimetal trips the shutdown mechanism.

Thermal device circuit breakers represent a simple, cost-effective alternative for applications that do not necessarily require fast, precise shutdowns.

Thermal miniature circuit breaker with operating lever for restarting

Thermal miniature circuit breakers with a snap plate as thermal bimetal are designed with extremely compact dimensions. The main switching contact is directly secured to the washer. These versions feature a somewhat faster-blowing tripping characteristic than those with bimetal strips.

They are primarily used for protecting integrated circuits in battery and onboard systems with up to 32 V DC. The nominal currents are in the single- or two-digit ampere range. Thermal miniature circuit breakers can be switched on again after tripping by means of a button. Lower nominal currents are protected by other types of protective devices.

Thermal circuit breaker with latch for switching on and off

This particular design of circuit breakers works with a thermal bimetal strip. Equipment is switched off by means of a spring-loaded contact mechanism. The switch enables protective devices to be switched on and off. A setting screw is used to adjust the shutdown time to the default settings. This also sets the preload for the thermal bimetal, which activates the trip mechanism.

The nominal currents start in the milliamp range and extend up to the two-digit amp range. They are suitable for use up to 250 V AC or 65 V DC.

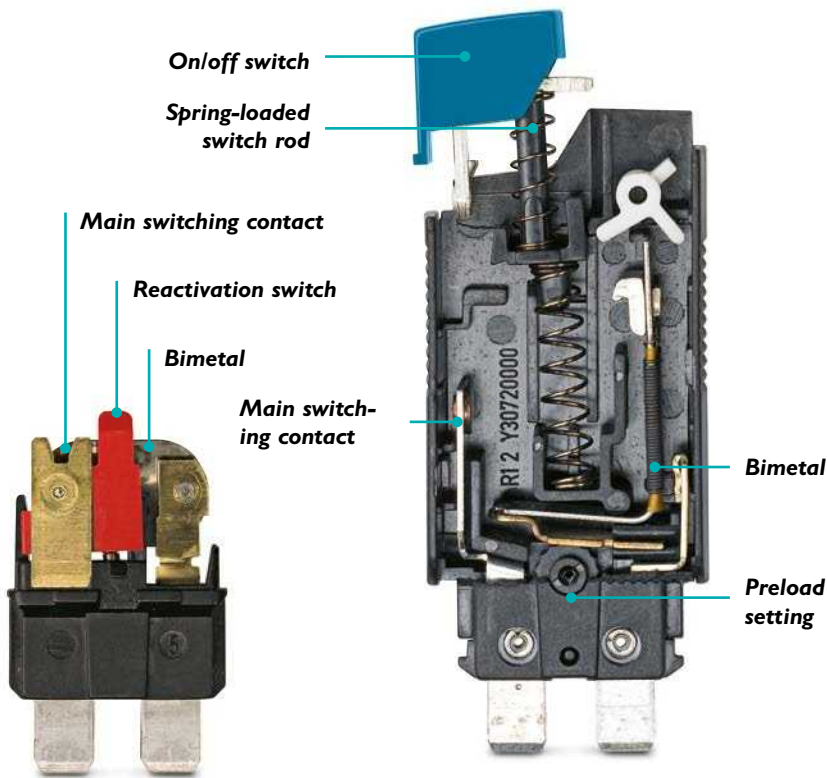

Internal design: thermal miniature circuit breaker with operating lever for restarting

Internal design: thermal circuit breaker with latch for switching on and off

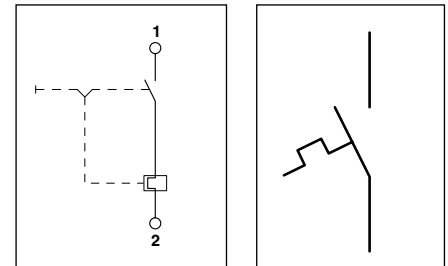

Functional circuit diagram circuit diagram thermal miniature circuit breaker

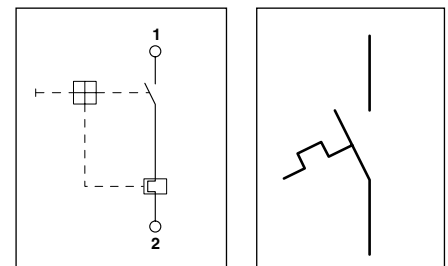

Functional circuit diagram circuit diagram thermal circuit breaker

Tripping characteristics

The tripping time of thermal device circuit breakers depends on the applied overload current and ambient temperature. The characteristic curves indicate that the tripping time is reached faster as the overload increases. With smaller overload currents, it therefore takes longer for the connected load to be disconnected from the power supply. For circuit breakers with different nominal currents yet the same tripping characteristics, the tripping behavior can also be presented in characteristic curve fields.

By their nature, thermal device circuit breakers respond to the influence of heat. The ambient temperature also influences the tripping time. The circuit breaker trips more easily at a high ambient temperature and, in turn, more slowly at a low ambient temperature. This behavior is indicated by additional characteristic curves with corresponding temperature information.

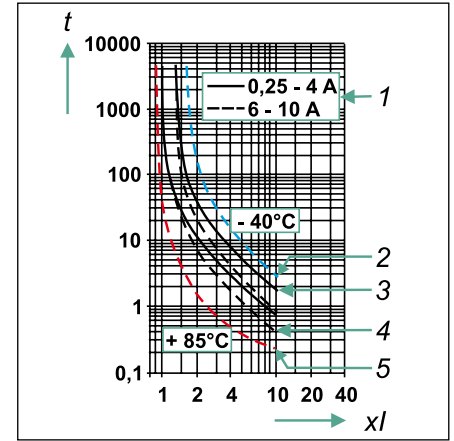

Typical tripping characteristic of a thermal circuit breaker

- t Switching time (in seconds)
- xI Multiples of the nominal current/tripping factor
- 1 Current ranges of the characteristic curve field
- 2 Tripping characteristic of the lower temperature range (blue)
- 3 Tripping characteristics group 1
- 4 Tripping characteristics group 2
- 5 Tripping characteristic of the upper temperature range (red)

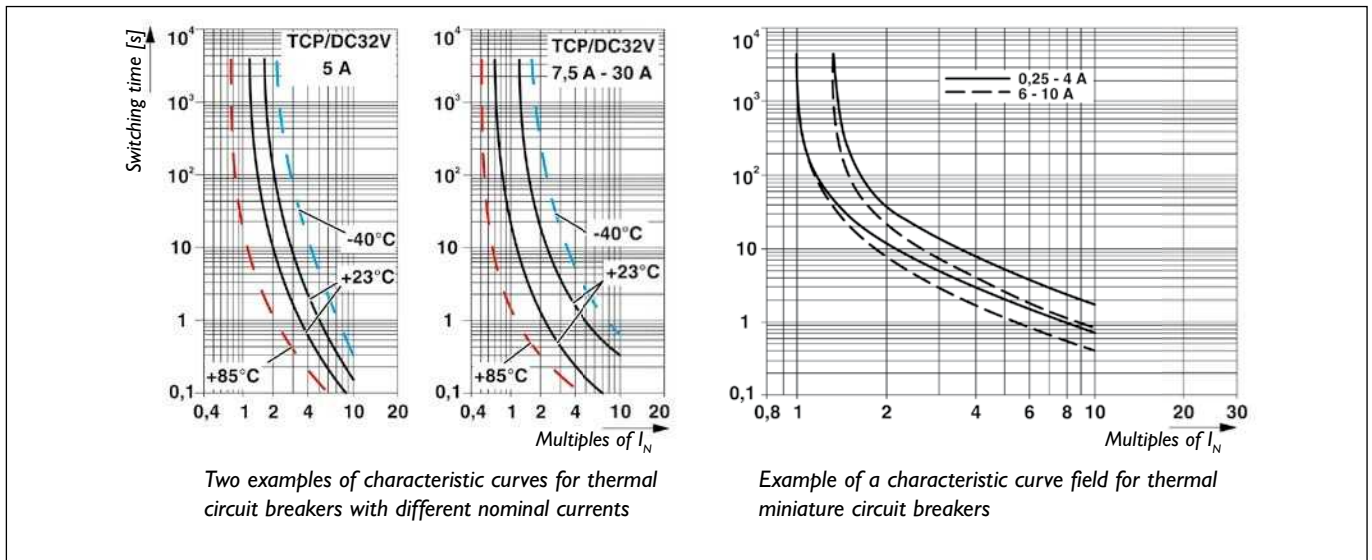

Two examples of characteristic curves for thermal circuit breakers with different nominal currents

Example of a characteristic curve field for thermal miniature circuit breakers

The key characteristic curves of thermal circuit breakers at a glance

12 The right power supply

The requirements for a power supply with reserves for future expansions should have already been defined in the planning stage, because these power supply requirements are continuously increasing. Important attributes for 24 V DC power supply units used in industrial applications are their size, to enable space-saving installation, and simultaneously, increasingly high levels of performance. Power supplies must match the power requirement of the terminal devices to be connected. Furthermore, no more than 80% of the nominal current should be planned for. This ensures that, in the event of a fault, a short-circuit current can be supplied which trips the circuit breaker quickly and safely. If the selected power supply is too small or the connection value is too high, then the necessary

current cannot be supplied. This results in an undervoltage, causing all system components to fail and the manufacturing process to be interrupted.

Quint power supplies from Phoenix Contact feature selective fuse breaking technology, also known as SFB. These power supplies can supply six times the nominal current for a few milliseconds. This enables them to provide the necessary current reserve for safe tripping of the protective devices. Together with thermomagnetic device circuit breakers equipped with SFB tripping characteristics, they form a reliable unit. This ensures superior system availability.

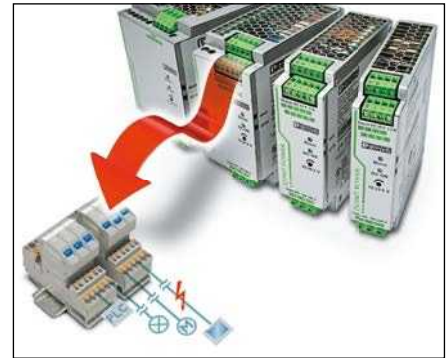

Reliable unit for quick shutdown during overloads or short circuits: industrial power supplies with SFB technology and device circuit breakers with the SFB characteristic curve

13 Redundant power supply

A redundant power supply significantly increases availability and productivity. Neither connection errors and short circuits nor voltage dips in a primary supply branch affect the output voltage. This is particularly useful for sensitive processes and key system areas.

In a redundant system, the power supplies must be designed so that they can be decoupled from one another. Redundancy modules equipped with a wide range of performance features assume this task. For example, the load can be optimally distributed to both power supplies in error-free operation. Depending on the design, the input voltage and output current can be continually monitored. If one power supply fails, the other takes over immediately.

Redundantly installed supply cables prevent line faults between the redundancy module and the load. The application example illustrates

the redundant design from the power supply through to protection with the device circuit breaker board. Equipped with double power terminal blocks, the board enables two supply cables to be connected.



Power supplies, redundancy module and device circuit breaker board

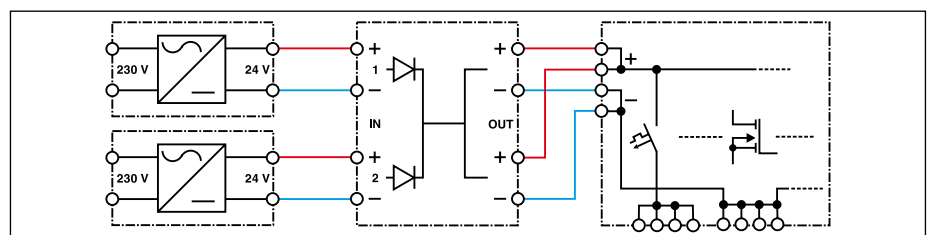

Two power supplies feed the device circuit breaker board via a redundancy module

14 Standards

Device circuit breakers are designed for use in low-voltage switchgears. For device circuit breakers, the DIN EN 60934 standard applies. The standard specifies technical requirements for protective devices, which must be met in order to reliably protect cables and devices. The standard states that device circuit breakers should have a higher rated switching capacity than is required for overload conditions. Together with prescribed short-circuit equipment, they have a conditional rated short-circuit current.

Manufacturers of device circuit breakers offer nominal current strengths from approximately 0.5 A to 16 A with various tripping

characteristics. As such, users can precisely tailor their safety equipment to the requirements of their system and therefore ensure high availability.

DIN EN 60934 can also be applied to switching devices used to protect electrical equipment in the event of undervoltage and/or surge voltage. It is applicable to AC voltages up to 440 V and/or for DC voltage up to 250 V at a rated current of up to 125 A and a rated short-circuit current breaking capacity of up to 3000 A. This standard contains all of the necessary requirements to ensure adherence to the necessary operating parameters for these devices, by means of the type test.

UL 2367 is used as the basis for electronic circuit breakers without electrical isolation.

15 Additional information

For additional product information and selection guides, such as a learning module, configurator, configuration matrix, product brochure and

technology, visit:
phoenixcontact.net/webcode/#0156

16 Glossary

80-% early warning

The early warning signals that 80 % of the preset nominal current has been reached for each channel.

Ambient temperature

This is the air temperature surrounding the equipment under specified conditions.

Auxiliary contact

This is the contact in the auxiliary circuit which is operated mechanically. It functions as a remote indication contact.

Changeover contact

This is a signal contact with three connections that provide N/C contact and N/O contact functions.

Circuit breakers

These are used to protect cables from damage that can occur as a consequence of an overload or short circuit.

Clearance

This is the shortest distance between two conductive parts.

Connection method

Specification for conductor connection technology, e.g. a screw terminal block or screwless push-in connection.

Creepage distance

This is the shortest distance along the surface of an insulation material between two conductive parts.

Device circuit breakers

Circuit breakers, which protect from possible defects as a result of short circuit or overload. They are specially designed to protect devices and actuators in technical systems and machines.

Electronic locking mechanism

This locking mechanism prevents an accidental adjustment to the nominal current of each channel once it is adjusted.

Fuses

They open a circuit and shut off the current if a permitted current value is exceeded over a long period of time.

Main contact

This is the contact in the main circuit which conducts the current when closed.

Mounting method

Type of installation option for device circuit breakers, such as design, installation or distributor type.

MTBF: Mean Time Between Failures

The expected value of the operating time between two consecutive failures.

N/C contact

This is a floating auxiliary contact. It is open if the main contact is closed.

N/O contact

This is a floating auxiliary contact. It is closed if the main contact is also closed.

Number of positions

This number specifies how many electrically separated current paths can be connected. There are device circuit breakers with different numbers of positions.

Operating characteristic curves

Characteristic curves which describe the behavior of a device circuit breaker under specific current and voltage values.

Overcurrent

This is a current that exceeds the rated current.

Overload current

This is overcurrent that occurs in an undamaged electric circuit.

Rated current, rated voltage

This is the current or voltage value of the device circuit breaker for a particular operating condition, as specified by the manufacturer. These values are related to the operating and performance features.

Rated values

Values for which equipment is measured, e.g., rated current, voltage, frequency.

SFB characteristic curve, selective fuse breaking (in thermomagnetic circuit breakers)

Device circuit breakers which work on the basis of this characteristic curve always trip in the event of a short circuit. The SFB tripping characteristic is between the M1 and F1 characteristic curve.

SFB technology, selective fuse breaking (in power supplies)

Power supplies which work on the basis of this technology provide a high current reserve in the event of a short circuit. Even for long cable paths, the safety equipment is supplied with the required breaking current. Unaffected system parts, which are also connected to this power supply, continue to be supplied with power.

Short-circuit current

This current arises between a faulty, low-resistance connection between two points, which usually have different potentials.

Switching cycles

The sequence of actuations from one position to another and back.

Temporary electric strength

This is the maximum temporary voltage value which can be tolerated without causing any insulation damage under specified conditions.

Trip-free mechanism

Tripping of a device circuit breaker without altering the switch position of the operating lever.

Tripping characteristics

They display the tripping characteristics of a device circuit breaker. The switching time and amperage at which a circuit breaker trips are shown in a diagram.

Type of actuation

Describes how a device circuit breaker is operated or reset. Versions are available with automatic reset or versions with manual actuation. These are equipped with an operating lever for regular or irregular switching operations.



Always up-to-date, always available to you. Here you'll find everything on our products, solutions and service:

phoenixcontact.com

Product range

- Cables and wires
- Connectors
- Controllers
- Electronics housings
- Electronic switchgear and motor control
- Fieldbus components and systems
- Functional safety
- HMIs and industrial PCs
- I/O systems
- Industrial communication technology
- Industrial Ethernet
- Installation and mounting material
- Lighting and signaling
- Marking and labeling
- Measurement and control technology
- Modular terminal blocks
- Monitoring
- PCB terminal blocks and PCB connectors
- Power supply units and UPS
- Protective devices
- Relay modules
- Sensor/actuator cabling
- Software
- Surge protection and interference filters
- System cabling for controllers
- Tools
- Wireless data communication

PHOENIX CONTACT GmbH & Co. KG
Flachmarktstraße 8
32825 Blomberg, Germany
Phone: + 49 5235 3-00
Fax: + 49 5235 3-41200
E-mail: info@phoenixcontact.com
phoenixcontact.com