

LIPS[®] P111 RUGGED STAND-ALONE LINEAR POSITION SENSOR

Position feedback for industrial and scientific applications

- Non-contacting inductive technology to eliminate wear
- Travel set to customer's requirement
- Compact and self-contained
- High durability and reliability
- High accuracy and stability
- Sealing to IP65/IP67 as required

As a leading designer and manufacturer of linear, rotary, tilt and intrinsically safe position sensors, Positek[®] has the expertise to supply a sensor to suit a wide variety of applications.

Our P111 LIPS[®] (Linear Inductive Position Sensor) is a heavy-duty version of the P101 sensor with a stronger 12.7mm push rod, recommended for applications where vibration is an issue or there is a need for longer travel sensors, mounted horizontally, and supported between rod eyes. It remains an affordable, durable, high-accuracy position sensor designed for industrial and scientific feedback applications. The unit is highly compact and space-efficient, being responsive along almost its entire length. Like all Positek[®] sensors, the P111 provides a linear output proportional to displacement. Each sensor is supplied with the output calibrated to the travel required by the customer, from 5 to 800mm and with full EMC protection built in.

The sensor is very robust, the body and push rod being made of stainless steel for long service life and environmental resistance. It is particularly suitable for OEMs seeking good sensor performance for arduous applications such as industrial machinery where cost is important. Overall performance, repeatability and stability are outstanding over a wide temperature range. The sensor is easy to install with mounting options including M8 rod eye bearings and body clamps. The push rod can be supplied free or captive, with female M8 thread, an M8 rod eye, or dome end. Captive push rods can be sprung loaded, in either direction, on sensors up to 250mm of travel. The P111 also offers a wide range of mechanical and electrical options, environmental sealing is to IP65 or IP67, depending on selected cable or connector options.



SPECIFICATION

DIMENSIONS	
Body diameter	35 mm
Body length (Axial version)	measurement length + 163 mm
Body length (Radial version)	measurement length + 186 mm
Push rod extension	measurement length + 7mm, OD 12.65mm
<i>For full mechanical details see drawing P111-11</i>	
Independent linearity	< ± 0.25% up to 450mm @ 20°C < ± 0.5% over 450mm @ 20°C
Temperature coefficients	< ± 0.01%/°C Gain & < ± 0.01%FS/°C Offset
Frequency response	> 10 kHz (-3dB) > 300 Hz (-3dB) 2 wire 4 to 20 mA
Resolution	Infinite
Noise	< 0.02% FSO
Environmental Temperature Limits	
Operating	-40 to +125°C standard -20 to +85°C buffered
Storage	-40 to +125°C
Sealing	IP65/IP67 depending on connector / cable option
EMC Performance	EN 61000-6-2, EN 61000-6-3
Vibration	IEC 68-2-6: 10g
Shock	IEC 68-2-29: 40 g
MTBF	350,000 hrs 40°C Gf
Drawing List	
P111-11	Sensor Outline
<i>Drawings, in AutoCAD[®] dwg or dxf format, available on request.</i>	

Do you need a position sensor made to order to suit a particular installation requirement or specification? We'll be happy to modify any of our designs to suit your needs - please contact us with your requirements.

For further information please contact:

www.positek.com sales@positek.com

Tel: +44(0)1242 820027 fax: +44(0)1242 820615

Positek Ltd, Andoversford Industrial Estate, Cheltenham GL54 4LB U.K.

LIPS[®] P111 RUGGED STAND-ALONE LINEAR POSITION SENSOR

Position feedback for industrial and scientific applications

How Positek's PIPS[®] technology eliminates wear for longer life

Positek's PIPS[®] technology (Positek Inductive Position Sensor) is a major advance in displacement sensor design. PIPS[®]-based displacement transducers have the simplicity of a potentiometer with the life of an LVDT/RVDT.

PIPS[®] technology combines the best in fundamental inductive principles with advanced micro-electronic integrated circuit technology. A PIPS[®] sensor, based on simple inductive coils using Positek's ASIC control technology, directly measures absolute position giving a DC analogue output signal. Because there is no contact between moving electrical components, reliability is high and wear is eliminated for an exceptionally long life.

PIPS[®] overcomes the drawbacks of LVDT technology – bulky coils, poor length-to-stroke ratio and the need for special magnetic materials. It requires no separate signal conditioning.

Our LIPS[®] range are linear sensors, while RIPS[®] are rotary units and TIPS[®] are for detecting tilt position. Ask us for a full technical explanation of PIPS[®] technology.

We also offer a range of ATEX-qualified intrinsically-safe sensors.

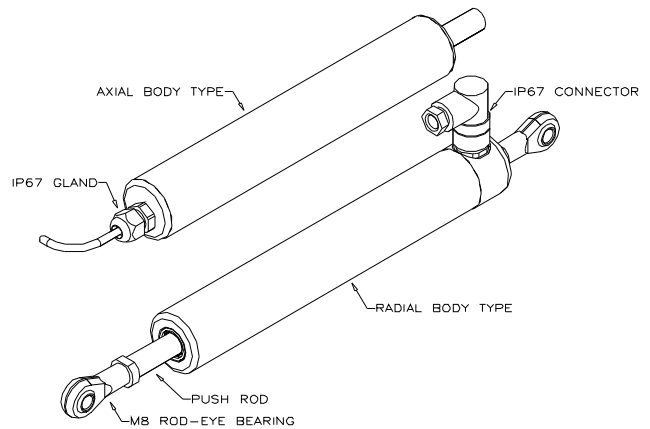

TABLE OF OPTIONS

MEASUREMENT RANGE: Factory-set to any length from 5 to 800 mm in increments of 1mm.

ELECTRICAL INTERFACE OPTIONS

OUTPUT SIGNAL	SUPPLY INPUT	OUTPUT LOAD
Standard:		
0.5-4.5V dc ratiometric	+5V dc nom. ± 0.5V.	5kΩ min.
Buffered:		
0.5-4.5V dc	+24V dc nom. + 9-28V.	5kΩ min.
±5V dc	±15V dc nom. ± 9-28V.	5kΩ min.
0.5-9.5V dc	+24V dc nom. + 13-28V.	5kΩ min.
±10V dc	±15 V dc nom. ± 13.5-28V.	5kΩ min.
Supply Current	10mA typical, 20mA maximum.	
4-20mA (2 wire)	+24 V dc nom. + 18-28V.	300Ω @ 24V.
(3 wire sink)	+24 V dc nom. + 13-28V.	950Ω @ 24V.
(3 wire source)	+24 V dc nom. + 13-28V.	300Ω max.

Option for output 'zero' and 'span' adjustment available (axial version).

CONNECTOR/CABLE OPTIONS

Connector - Hirschmann GD series	Axial, IP65
Connector - Hirschmann ELWIK 4102	Radial, IP67
Cable with M12 gland or short gland	Axial, IP67
Cable with PG9 gland	Radial, IP67
Cable length >50cm – please specify length in cm	

MOUNTING OPTIONS

M8 rod eye bearing (radial versions), Body Tube Clamp/s (axial or radial versions).

PUSH ROD OPTIONS – standard retained with M8x1.25 female thread M8 rod eye bearing, Dome end, Sprung loaded (retraction or extension) or Free.

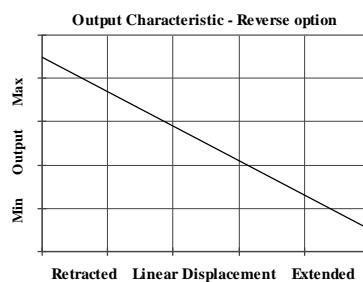
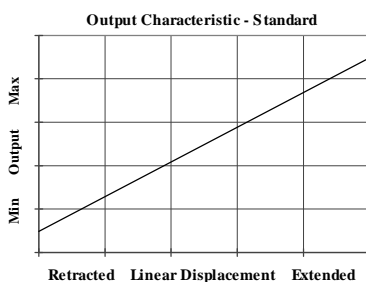

For further information please contact:

www.positek.com sales@positek.com

Tel: +44(0)1242 820027 fax: +44(0)1242 820615

Positek Ltd, Andoversford Industrial Estate, Cheltenham GL54 4LB U.K.