

SEE DRAWING TG24-11 FOR TARGET TUBE FLANGE OPTIONS 'V', 'W' & 'X'.

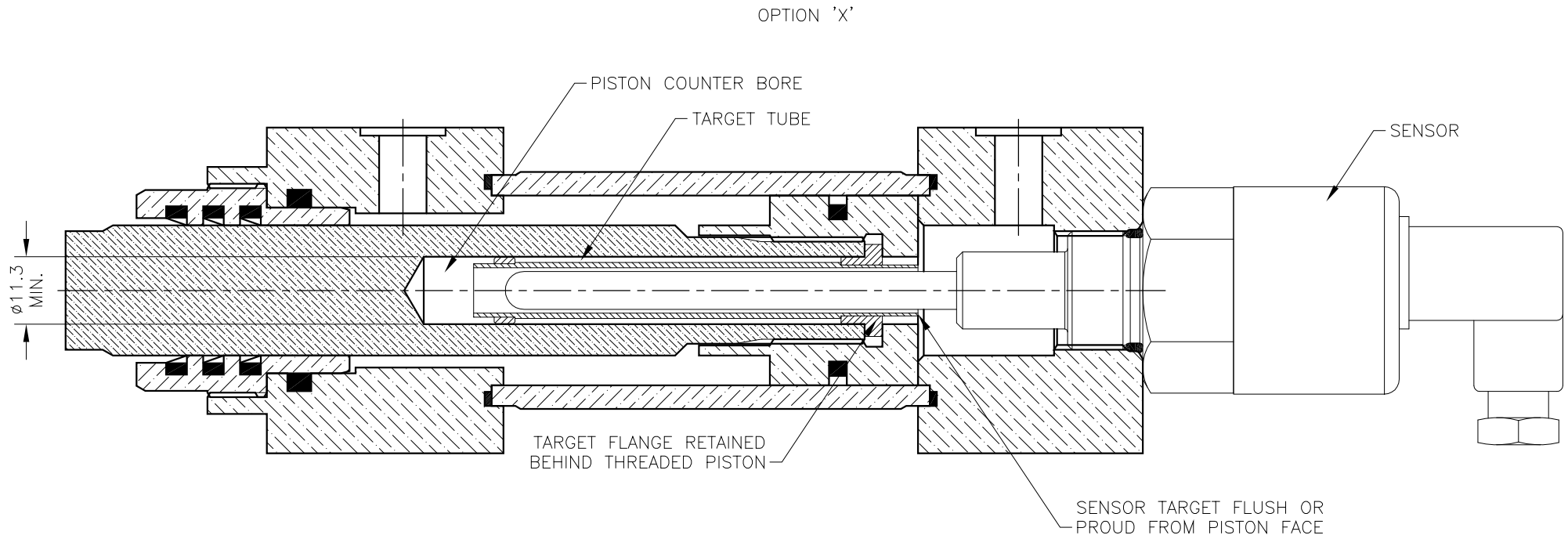

A	FIRST ISSUE.	RDS
B	REDRAWN.	PDM

DRAWINGS NOT TO BE CHANGED WITHOUT REFERENCE TO THE CHANGE PROCEDURE.
 CHANGES TO PARTS USED IN INTRINSICALLY SAFE PRODUCT MUST BE APPROVED
 BY THE AUTHORISED PERSON
 THIS IS AN UNCONTROLLED PRINT AND WILL NOT BE UPDATED.

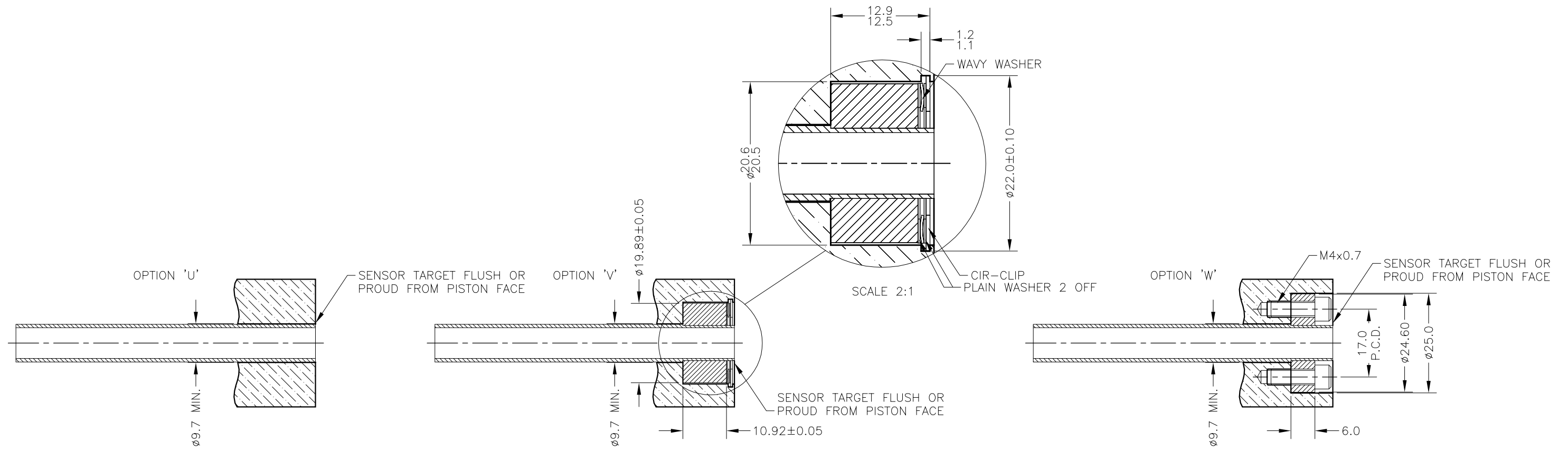
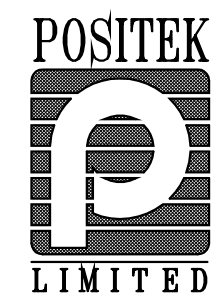

A	28/06/95		CHECKED BY	X	±0.4
B	04/10/11		RDS	X.X	±0.2
					DIMS mm
DESCRIPTION					
TYPICAL TARGET TUBE FITTING OPTIONS					
SCALE					
10mm					
DRAWING NUMBER P100-12 REV B					
SHEET 1 OF 1					